



**LTE;  
Evolved Universal Terrestrial Radio Access (E-UTRA);  
User Equipment (UE) radio transmission and reception  
(3GPP TS 36.101 version 16.8.0 Release 16)**



---

**Reference**

RTS/TSGR-0436101vg80

---

**Keywords**

LTE

**ETSI**

---

650 Route des Lucioles  
F-06921 Sophia Antipolis Cedex - FRANCE

Tel.: +33 4 92 94 42 00 Fax: +33 4 93 65 47 16

Siret N° 348 623 562 00017 - NAF 742 C  
Association à but non lucratif enregistrée à la  
Sous-Préfecture de Grasse (06) N° 7803/88

---

**Important notice**

The present document can be downloaded from:  
<http://www.etsi.org/standards-search>

The present document may be made available in electronic versions and/or in print. The content of any electronic and/or print versions of the present document shall not be modified without the prior written authorization of ETSI. In case of any existing or perceived difference in contents between such versions and/or in print, the prevailing version of an ETSI deliverable is the one made publicly available in PDF format at [www.etsi.org/deliver](http://www.etsi.org/deliver).

Users of the present document should be aware that the document may be subject to revision or change of status. Information on the current status of this and other ETSI documents is available at <https://portal.etsi.org/TB/ETSIDeliverableStatus.aspx>

If you find errors in the present document, please send your comment to one of the following services:  
<https://portal.etsi.org/People/CommiteeSupportStaff.aspx>

---

**Copyright Notification**

No part may be reproduced or utilized in any form or by any means, electronic or mechanical, including photocopying and microfilm except as authorized by written permission of ETSI.  
The content of the PDF version shall not be modified without the written authorization of ETSI.  
The copyright and the foregoing restriction extend to reproduction in all media.

© ETSI 2021.  
All rights reserved.

**DECT™**, **PLUGTESTS™**, **UMTS™** and the ETSI logo are trademarks of ETSI registered for the benefit of its Members.  
**3GPP™** and **LTE™** are trademarks of ETSI registered for the benefit of its Members and of the 3GPP Organizational Partners.  
**oneM2M™** logo is a trademark of ETSI registered for the benefit of its Members and of the oneM2M Partners.  
**GSM®** and the GSM logo are trademarks registered and owned by the GSM Association.

**ETSI**

---

## Intellectual Property Rights

### Essential patents

IPRs essential or potentially essential to normative deliverables may have been declared to ETSI. The information pertaining to these essential IPRs, if any, is publicly available for **ETSI members and non-members**, and can be found in ETSI SR 000 314: "*Intellectual Property Rights (IPRs); Essential, or potentially Essential, IPRs notified to ETSI in respect of ETSI standards*", which is available from the ETSI Secretariat. Latest updates are available on the ETSI Web server (<https://ipr.etsi.org/>).

Pursuant to the ETSI IPR Policy, no investigation, including IPR searches, has been carried out by ETSI. No guarantee can be given as to the existence of other IPRs not referenced in ETSI SR 000 314 (or the updates on the ETSI Web server) which are, or may be, or may become, essential to the present document.

### Trademarks

The present document may include trademarks and/or tradenames which are asserted and/or registered by their owners. ETSI claims no ownership of these except for any which are indicated as being the property of ETSI, and conveys no right to use or reproduce any trademark and/or tradename. Mention of those trademarks in the present document does not constitute an endorsement by ETSI of products, services or organizations associated with those trademarks.

---

## Legal notice

This Technical Specification (TS) has been produced by the ETSI 3<sup>rd</sup> Generation Partnership Project (3GPP).

The present document may refer to technical specifications or reports using their 3GPP identities. These shall be interpreted as being references to the corresponding ETSI deliverables.

The cross reference between 3GPP and ETSI identities can be found under <http://webapp.etsi.org/key/queryform.asp>.

---

## Modal verbs terminology

In the present document "**shall**", "**shall not**", "**should**", "**should not**", "**may**", "**need not**", "**will**", "**will not**", "**can**" and "**cannot**" are to be interpreted as described in clause 3.2 of the [ETSI Drafting Rules](#) (Verbal forms for the expression of provisions).

"**must**" and "**must not**" are **NOT** allowed in ETSI deliverables except when used in direct citation.

# Contents

Intellectual Property Rights .....	2
Legal notice .....	2
Modal verbs terminology .....	2
Foreword .....	32
1 Scope .....	34
2 References .....	34
3 Definitions, symbols and abbreviations .....	34
3.1 Definitions .....	34
3.2 Symbols .....	36
3.3 Abbreviations .....	39
4 General .....	41
4.1 Relationship between minimum requirements and test requirements .....	41
4.2 Applicability of minimum requirements .....	41
4.3 Void .....	41
4.3A Applicability of minimum requirements (CA, UL-MIMO, ProSe, Dual Connectivity, UE category 0, UE category M1, UE category M2, UE category 1bis, UE category NB1 and NB2, V2X Communication, MBMS UE) .....	41
4.4 RF requirements in later releases .....	43
5 Operating bands and channel arrangement .....	43
5.1 General .....	43
5.2 Void .....	43
5.3 Void .....	43
5.4 Void .....	43
5.5 Operating bands .....	43
5.5A Operating bands for CA .....	46
5.5B Operating bands for UL-MIMO .....	65
5.5C Operating bands for Dual Connectivity .....	65
5.5D Operating bands for ProSe .....	68
5.5E Operating bands for UE category 0, UE category M1 and M2 and UE category 1bis .....	69
5.5F Operating bands for category NB1 and NB2 .....	69
5.5G Operating bands for V2X Communication .....	69
5.6 Channel bandwidth .....	70
5.6.1 Channel bandwidths per operating band .....	71
5.6A Channel bandwidth for CA .....	74
5.6A.1 Channel bandwidths per operating band for CA .....	76
5.6B Channel bandwidth for UL-MIMO .....	178
5.6B.1 Void .....	178
5.6C Channel bandwidth for Dual Connectivity .....	178
5.6C.1 Void .....	178
5.6D Channel bandwidth for ProSe .....	178
5.6D.1 Channel bandwidths per operating band for ProSe .....	178
5.6F Channel bandwidth for category NB1 and NB2 .....	179
5.6G Channel bandwidth for V2X Communication .....	180
5.6G.1 Channel bandwidths per operating band for V2X Communication .....	180
5.7 Channel arrangement .....	182
5.7.1 Channel spacing .....	182
5.7.1A Channel spacing for CA .....	182
5.7.1F Channel spacing for category NB1 and NB2 .....	183
5.7.2 Channel raster .....	183
5.7.2A Channel raster for CA .....	183
5.7.2F Channel raster for category NB1 and NB2 .....	183
5.7.3 Carrier frequency and EARFCN .....	183
5.7.3F Carrier frequency and EARFCN for category NB1 and NB2 .....	186

5.7.4	TX–RX frequency separation .....	186
5.7.4A	TX–RX frequency separation for CA .....	187
5.7.4E	TX–RX frequency separation for category M1 and M2 .....	187
5.7.4F	TX–RX frequency separation for category NB1 and NB2 .....	188
6	Transmitter characteristics .....	188
6.1	General .....	188
6.2	Transmit power .....	188
6.2.1	Void .....	188
6.2.2	UE maximum output power .....	188
6.2.2A	UE maximum output power for CA .....	191
6.2.2B	UE maximum output power for UL-MIMO .....	196
6.2.2C	Void .....	199
6.2.2D	UE maximum output power for ProSe .....	199
6.2.2E	UE maximum output power for Category M1 and M2 UE .....	199
6.2.2F	UE maximum output power for category NB1 and NB2 .....	200
6.2.2G	UE maximum output power for V2X Communication .....	201
6.2.3	UE maximum output power for modulation / channel bandwidth .....	203
6.2.3A	UE Maximum Output power for modulation / channel bandwidth for CA .....	204
6.2.3B	UE maximum output power for modulation / channel bandwidth for UL-MIMO .....	209
6.2.3D	UE maximum output power for modulation / channel bandwidth for ProSe .....	209
6.2.3E	UE maximum output power for modulation / channel bandwidth for category M1 and M2 .....	210
6.2.3F	UE maximum output power for modulation / channel bandwidth for category NB1 and NB2 .....	212
6.2.3G	UE maximum output power for modulation / channel bandwidth for V2X Communication .....	212
6.2.3G.1	MPR for Power class 3 V2X UE .....	212
6.2.3G.2	MPR for Power class 2 V2X UE .....	214
6.2.4	UE maximum output power with additional requirements .....	214
6.2.4A	UE maximum output power with additional requirements for CA .....	233
6.2.4A.1	A-MPR for CA_NS_01 for CA_1C .....	235
6.2.4A.2	A-MPR for CA_NS_02 for CA_1C .....	235
6.2.4A.3	A-MPR for CA_NS_03 for CA_1C .....	236
6.2.4A.4	A-MPR for CA_NS_04 .....	237
6.2.4A.5	A-MPR for CA_NS_05 for CA_38C .....	239
6.2.4A.6	A-MPR for CA_NS_06 .....	240
6.2.4A.7	A-MPR for CA_NS_07 .....	241
6.2.4A.8	A-MPR for CA_NS_08 .....	242
6.2.4A.9	Void .....	243
6.2.4A.10	A-MPR for CA_NS_10 .....	243
6.2.4B	UE maximum output power with additional requirements for UL-MIMO .....	248
6.2.4D	UE maximum output power with additional requirements for ProSe .....	248
6.2.4E	UE maximum output power with additional requirements for category M1 and M2 UE .....	248
6.2.4F	UE maximum output power with additional requirements for category NB1 and NB2 UE .....	257
6.2.4G	UE maximum output power with additional requirements for V2X Communication .....	258
6.2.5	Configured transmitted power .....	260
6.2.5A	Configured transmitted power for CA .....	291
6.2.5B	Configured transmitted power for UL-MIMO .....	295
6.2.5C	Configured transmitted power for Dual Connectivity .....	295
6.2.5D	Configured transmitted power for ProSe .....	297
6.2.5F	Configured transmitted Power for category NB1 and NB2 .....	298
6.2.5G	Configured transmitted power for V2X Communication .....	299
6.3	Output power dynamics .....	303
6.3.1	(Void) .....	303
6.3.2	Minimum output power .....	303
6.3.2.1	Minimum requirement .....	303
6.3.2A	UE Minimum output power for CA .....	303
6.3.2A.1	Minimum requirement for CA .....	304
6.3.2B	UE Minimum output power for UL-MIMO .....	304
6.3.2B.1	Minimum requirement .....	304
6.3.2C	Void .....	304
6.3.2D	UE Minimum output power for ProSe .....	304
6.3.2F	UE Minimum output power for category NB1 and NB2 .....	305
6.3.2G	UE Minimum output power for V2X Communication .....	305

6.3.3	Transmit OFF power .....	305
6.3.3.1	Minimum requirement .....	305
6.3.3A	UE Transmit OFF power for CA .....	306
6.3.3A.1	Minimum requirement for CA .....	306
6.3.3B	UE Transmit OFF power for UL-MIMO .....	306
6.3.3B.1	Minimum requirement .....	306
6.3.3D	Transmit OFF power for ProSe .....	307
6.3.3F	Transmit OFF power for category NB1 and NB2 .....	307
6.3.3G	Transmit OFF power for V2X Communication .....	307
6.3.4	ON/OFF time mask .....	308
6.3.4.1	General ON/OFF time mask .....	308
6.3.4.2	PRACH and SRS time mask .....	309
6.3.4.2.1	PRACH time mask .....	309
6.3.4.2.2	SRS time mask .....	310
6.3.4.3	Slot / Sub frame boundary time mask for subframe TTI .....	312
6.3.4.4	PUCCH / PUSCH / SRS time mask for subframe TTI .....	314
6.3.4.5	Symbol / Subslot boundary time mask for subslot TTI .....	316
6.3.4.6	Subslot PUCCH / subslot PUSCH / SRS time mask for subslot TTI .....	317
6.3.4.7	Symbol / Slot boundary time mask for slot TTI .....	320
6.3.4.8	Slot PUCCH / slot PUSCH / SRS time mask for slot TTI .....	321
6.3.4.9	Consecutive subslot and slot TTI or consecutive subslot and subframe TTI time mask .....	321
6.3.4.10	Consecutive subframe and subslot TTI or consecutive slot and subslot TTI time mask .....	321
6.3.4.11	Consecutive TTI and slot TTI or consecutive slot TTI and TTI time mask .....	322
6.3.4A	ON/OFF time mask for CA .....	323
6.3.4B	ON/OFF time mask for UL-MIMO .....	323
6.3.4D	ON/OFF time mask for ProSe .....	323
6.3.4D.1	General time mask for ProSe .....	323
6.3.4D.2	PSSS/SSSS time mask .....	324
6.3.4D.3	PSSS / SSSS / PSBCH time mask .....	325
6.3.4D.4	PSSCH / SRS time mask .....	325
6.3.4F	ON/OFF time mask for category NB1 and NB2 .....	325
6.3.4F.1	General ON/OFF time mask .....	325
6.3.4F.2	NPRACH time mask .....	326
6.3.4G	ON/OFF time mask for V2X Communication .....	326
6.3.4G.1	PSSS / SSSS / PSBCH time mask .....	327
6.3.5	Power Control .....	327
6.3.5.1	Absolute power tolerance .....	327
6.3.5.1.1	Minimum requirements .....	327
6.3.5.2	Relative Power tolerance .....	328
6.3.5.2.1	Minimum requirements .....	328
6.3.5.3	Aggregate power control tolerance .....	329
6.3.5.3.1	Minimum requirement .....	329
6.3.5A	Power control for CA .....	329
6.3.5A.1	Absolute power tolerance .....	329
6.3.5A.1.1	Minimum requirements .....	329
6.3.5A.2	Relative power tolerance .....	330
6.3.5A.2.1	Minimum requirements .....	330
6.3.5A.3	Aggregate power control tolerance .....	330
6.3.5A.3.1	Minimum requirements .....	330
6.3.5B	Power control for UL-MIMO .....	331
6.3.5D	Power Control for ProSe .....	331
6.3.5D.1	Absolute power tolerance .....	331
6.3.5E	Power control for category M1 and M2 .....	331
6.3.5E.1	Absolute power tolerance .....	331
6.3.5E.2	Relative Power tolerance .....	331
6.3.5E.3	Aggregate power control tolerance .....	332
6.3.5E.3.1	Minimum requirement .....	332
6.3.5F	Power Control for category NB1 and NB2 .....	332
6.3.5F.1	Absolute power tolerance .....	333
6.3.5F.2	Relative power tolerance .....	333
6.3.5F.3	Aggregate power control tolerance for category NB1 and NB2 .....	334
6.3.5F.3.1	Minimum requirement .....	334

6.3.5G	Power Control for V2X Communication .....	334
6.3.5G.1	Absolute power tolerance .....	334
6.4	Void .....	335
6.5	Transmit signal quality .....	335
6.5.1	Frequency error .....	335
6.5.1A	Frequency error for CA .....	335
6.5.1B	Frequency error for UL-MIMO .....	335
6.5.1D	Frequency error for ProSe .....	335
6.5.1E	Frequency error for UE category M1 and M2 .....	335
6.5.1F	Frequency error for UE category NB1 and NB2 .....	336
6.5.1G	Frequency error for V2X Communication .....	336
6.5.2	Transmit modulation quality .....	336
6.5.2.1	Error Vector Magnitude .....	337
6.5.2.1.1	Minimum requirement .....	337
6.5.2.2	Carrier leakage .....	337
6.5.2.2.1	Minimum requirements .....	338
6.5.2.3	In-band emissions .....	338
6.5.2.3.1	Minimum requirements .....	338
6.5.2.4	EVM equalizer spectrum flatness .....	339
6.5.2.4.1	Minimum requirements .....	339
6.5.2A	Transmit modulation quality for CA .....	340
6.5.2A.1	Error Vector Magnitude .....	341
6.5.2A.2	Carrier leakage for CA .....	341
6.5.2A.2.1	Minimum requirements .....	341
6.5.2A.3	In-band emissions .....	341
6.5.2A.3.1	Minimum requirement for CA .....	341
6.5.2B	Transmit modulation quality for UL-MIMO .....	344
6.5.2B.1	Error Vector Magnitude .....	344
6.5.2B.2	Carrier leakage .....	344
6.5.2B.3	In-band emissions .....	344
6.5.2B.4	EVM equalizer spectrum flatness for UL-MIMO .....	344
6.5.2D	Transmit modulation quality for ProSe .....	344
6.5.2D.1	Error Vector Magnitude .....	344
6.5.2D.2	Carrier leakage .....	345
6.5.2D.3	In-band emissions .....	345
6.5.2D.4	EVM equalizer spectrum flatness for ProSe .....	345
6.5.2E	Transmit modulation quality for category M1 and M2 .....	345
6.5.2E.1	Error Vector Magnitude .....	345
The Error Vector Magnitude is defined in section 6.5.2.1 .....		345
6.5.2E.2	Carrier leakage .....	345
6.5.2E.2.1	Minimum requirements .....	345
6.5.2E.3	In-band emissions .....	345
6.5.2E.3.1	Minimum requirements .....	345
6.5.2F	Transmit modulation quality for Category NB1 and NB2 .....	347
6.5.2F.1	Error Vector Magnitude .....	347
6.5.2F.2	Carrier leakage .....	347
6.5.2F.3	In-band emissions .....	347
6.5.2G	Transmit modulation quality for V2X Communication .....	348
6.5.2G.1	Error Vector Magnitude .....	348
6.5.2G.2	Carrier leakage .....	349
6.5.2G.3	In-band emissions .....	349
6.5.2G.4	EVM equalizer spectrum flatness .....	349
6.6	Output RF spectrum emissions .....	349
6.6.1	Occupied bandwidth .....	349
6.6.1.1	Additional minimum requirement for E-UTRA (network signalled value "NS_29") .....	350
6.6.1A	Occupied bandwidth for CA .....	350
6.6.1B	Occupied bandwidth for UL-MIMO .....	350
6.6.1F	Occupied bandwidth for category NB1 and NB2 .....	351
6.6.1G	Occupied bandwidth for V2X Communication .....	351
6.6.2	Out of band emission .....	351
6.6.2.1	Spectrum emission mask .....	351
6.6.2.1.1	Minimum requirement .....	351

6.6.2.1A	Spectrum emission mask for CA .....	352
6.6.2.2	Additional spectrum emission mask .....	353
6.6.2.2.1	Minimum requirement (network signalled value "NS_03", "NS_11", "NS_20", and "NS_21") .....	353
6.6.2.2.2	Minimum requirement (network signalled value "NS_04") .....	354
6.6.2.2.3	Minimum requirement (network signalled value "NS_06" or "NS_07") .....	354
6.6.2.2.4	Minimum requirement (network signalled value "NS_33" or "NS_34") .....	355
6.6.2.2.5	Minimum requirement (network signalled value "NS_27" and "NS_43") .....	355
6.6.2.2.6	Minimum requirement (network signalled value "NS_28") .....	356
6.6.2.2.7	Minimum requirement (network signalled value "NS_35") .....	356
6.6.2.2A	Additional Spectrum Emission Mask for CA .....	357
6.6.2.2A.1	Minimum requirement (network signalled value "CA_NS_04") .....	357
6.6.2.2A.2	Minimum requirement CA_66B (network signalled value "CA_NS_09") .....	357
6.6.2.2A.3	Minimum requirement CA_66C (network signalled value "CA_NS_09") .....	358
6.6.2.2A.4	Minimum requirement CA_48B and CA_48C (network signalled value "CA_NS_10") .....	358
6.6.2.3	Adjacent Channel Leakage Ratio .....	359
6.6.2.3.1	Minimum requirement E-UTRA .....	359
6.6.2.3.1a	Additional minimum requirement for E-UTRA (network signalled value "NS_29") .....	360
6.6.2.3.1A	Void .....	361
6.6.2.3.1Aa	Void .....	361
6.6.2.3.2	Minimum requirements UTRA .....	361
6.6.2.3.2A	Minimum requirement UTRA for CA .....	362
6.6.2.3.3A	Minimum requirements for CA E-UTRA .....	364
6.6.2.4	Void .....	365
6.6.2.4.1	Void .....	365
6.6.2A	Void .....	365
6.6.2B	Out of band emission for UL-MIMO .....	365
6.6.2C	Void .....	365
6.6.2D	Out of band emission for ProSe .....	365
6.6.2F	Out of band emission for category NB1 and NB2 .....	366
6.6.2F.1	Spectrum emission mask .....	366
6.6.2F.2	Additional Spectrum Emission Mask for Category NB1 and NB2 .....	366
6.6.2F.2.1	Minimum requirement (network signalled value "NS_02") .....	366
6.6.2F.2.2	Minimum requirement (network signalled value "NS_03") .....	366
6.6.2F.3	Adjacent Channel Leakage Ratio for category NB1 and NB2 .....	367
6.6.2G	Out of band emission for V2X Communication .....	367
6.6.3	Spurious emissions .....	368
6.6.3.1	Minimum requirements .....	368
6.6.3.1A	Minimum requirements for CA .....	369
6.6.3.2	Spurious emission band UE co-existence .....	370
6.6.3.2A	Spurious emission band UE co-existence for CA .....	379
6.6.3.3	Additional spurious emissions .....	394
6.6.3.3.1	Minimum requirement (network signalled value "NS_05") .....	394
6.6.3.3.2	Minimum requirement (network signalled value "NS_07") .....	395
6.6.3.3.3	Minimum requirement (network signalled value "NS_08") .....	395
6.6.3.3.4	Minimum requirement (network signalled value "NS_09") .....	395
6.6.3.3.5	Minimum requirement (network signalled value "NS_12") .....	396
6.6.3.3.6	Minimum requirement (network signalled value "NS_13") .....	396
6.6.3.3.7	Minimum requirement (network signalled value "NS_14") .....	396
6.6.3.3.8	Minimum requirement (network signalled value "NS_15") .....	396
6.6.3.3.9	Minimum requirement (network signalled value "NS_16") .....	397
6.6.3.3.10	Minimum requirement (network signalled value "NS_17") .....	397
6.6.3.3.11	Minimum requirement (network signalled value "NS_18") .....	397
6.6.3.3.12	Minimum requirement (network signalled value "NS_19") .....	397
6.6.3.3.13	Minimum requirement (network signalled value "NS_11") .....	398
6.6.3.3.14	Minimum requirement (network signalled value "NS_20") .....	398
6.6.3.3.15	Minimum requirement (network signalled value "NS_21") .....	398
6.6.3.3.16	Minimum requirement (network signalled value "NS_22") .....	399
6.6.3.3.17	Minimum requirement (network signalled value "NS_23") .....	399
6.6.3.3.18	Void .....	400
6.6.3.3.19	Minimum requirement (network signalled value "NS_04") .....	400
6.6.3.3.20	Minimum requirement (network signalled value "NS_24") .....	400
6.6.3.3.21	Minimum requirement (network signalled value "NS_25") .....	401



6.6.3.3.22	Minimum requirement (network signalled value "NS_26")	401
6.6.3.3.23	Minimum requirement (network signalled value "NS_27" and "NS_43")	401
6.6.3.3.24	Minimum requirement (network signalled value "NS_28")	401
6.6.3.3.25	Minimum requirement (network signalled value "NS_29")	402
6.6.3.3.26	Minimum requirement (network signalled value "NS_30")	402
6.6.3.3.27	Minimum requirement (network signalled value "NS_31")	403
6.6.3.3.28	Minimum requirement (network signalled value "NS_36")	404
6.6.3.3.29	Minimum requirement (network signalled value "NS_38")	404
6.6.3.3.30	Minimum requirement (network signalled value "NS_39")	404
6.6.3.3.31	Minimum requirement (network signalled value "NS_40" and "NS_41")	405
6.6.3.3.32	Minimum requirement (network signalled value "NS_42")	405
6.6.3.3.33	Minimum requirement (network signalled value "NS_44")	405
6.6.3.3.34	Minimum requirement (network signalled value "NS_45")	405
6.6.3.3A	Additional spurious emissions for CA	406
6.6.3.3A.1	Minimum requirement for CA_1C (network signalled value "CA_NS_01")	406
6.6.3.3A.2	Minimum requirement for CA_1C (network signalled value "CA_NS_02")	406
6.6.3.3A.3	Minimum requirement for CA_1C (network signalled value "CA_NS_03")	407
6.6.3.3A.4	Minimum requirement for CA_38C (network signalled value "CA_NS_05")	407
6.6.3.3A.5	Minimum requirement for CA_7C (network signalled value "CA_NS_06")	407
6.6.3.3A.6	Minimum requirement for CA_39C and CA_39C-41A (network signalled value "CA_NS_07")	408
6.6.3.3A.7	Minimum requirement for CA_42C (network signalled value "CA_NS_08")	408
6.6.3.3A.8	Minimum requirement for CA_41C and CA_41D (network signalled value "CA_NS_04")	408
6.6.3.3A.9	Void	409
6.6.3.3A.10	Minimum requirement for CA_48B and CA_48C (network signalled value "CA_NS_10")	409
6.6.3A	Void	409
6.6.3B	Spurious emission for UL-MIMO	409
6.6.3C	Void	409
6.6.3D	Spurious emission for ProSe	409
6.6.3F	Spurious emission for category NB1 and NB2	410
6.6.3G	Spurious emission for V2X Communication	410
6.6A	Void	414
6.6B	Void	414
6.7	Transmit intermodulation	414
6.7.1	Minimum requirement	414
6.7.1A	Minimum requirement for CA	415
6.7.1B	Minimum requirement for UL-MIMO	415
6.7.1F	Minimum requirement for category NB1 and NB2	415
6.7.1G	Minimum requirement for V2X Communication	416
6.8	Void	416
6.8A	Void	416
6.8B	Time alignment error for UL-MIMO	416
6.8B.1	Minimum Requirements	416
6.8C	Void	417
6.8D	Void	417
6.8E	Void	417
6.8F	Void	417
6.8G	Time alignment error	417
7	Receiver characteristics	417
7.1	General	417
7.2	Diversity characteristics	418
7.3	Reference sensitivity power level	418
7.3.1	Minimum requirements (QPSK)	418
7.3.1A	Minimum requirements (QPSK) for CA	453
7.3.1B	Minimum requirements (QPSK) for UL-MIMO	553
7.3.1D	Minimum requirements (QPSK) for ProSe	553
7.3.1E	Minimum requirements (QPSK) for UE category 0, M1, M2 and 1bis	555
7.3.1F	Minimum requirements for UE category NB1 and NB2	564
7.3.1F.1	Reference sensitivity for UE category NB1 and NB2	564
7.3.1F.2	Void	565
7.3.1G	Minimum requirements (QPSK) for V2X	565

7.3.2	Void .....	567
7.4	Maximum input level .....	567
7.4.1	Minimum requirements .....	568
7.4.1A	Minimum requirements for CA .....	568
7.4.1B	Minimum requirements for UL-MIMO .....	569
7.4.1D	Minimum requirements for ProSe .....	569
7.4.1F	Minimum requirements for category NB1 and NB2 .....	570
7.4.1G	Minimum requirements for V2X .....	570
7.4A	Void .....	571
7.4A.1	Void .....	571
7.5	Adjacent Channel Selectivity (ACS) .....	571
7.5.1	Minimum requirements .....	571
7.5.1A	Minimum requirements for CA .....	572
7.5.1B	Minimum requirements for UL-MIMO .....	576
7.5.1D	Minimum requirements for ProSe .....	576
7.5.1F	Minimum requirements for category NB1 and NB2 .....	577
7.5.1G	Minimum requirements for V2X .....	578
7.6	Blocking characteristics .....	580
7.6.1	In-band blocking .....	580
7.6.1.1	Minimum requirements .....	580
7.6.1.1A	Minimum requirements for CA .....	582
7.6.1.1D	Minimum requirements for ProSe .....	585
7.6.1.1F	Minimum requirements for category NB1 and NB2 .....	586
7.6.1.1G	Minimum requirements for V2X .....	586
7.6.2	Out-of-band blocking .....	588
7.6.2.1	Minimum requirements .....	588
7.6.2.1A	Minimum requirements for CA .....	590
7.6.2.1D	Minimum requirements for ProSe .....	593
7.6.2.1F	Minimum requirements for category NB1 and NB2 .....	593
7.6.2.1G	Minimum requirements for V2X .....	594
7.6.3	Narrow band blocking .....	595
7.6.3.1	Minimum requirements .....	595
7.6.3.1A	Minimum requirements for CA .....	596
7.6.3.1D	Minimum requirements for ProSe .....	597
7.6A	Void .....	598
7.6B	Blocking characteristics for UL-MIMO .....	598
7.7	Spurious response .....	598
7.7.1	Minimum requirements .....	598
7.7.1A	Minimum requirements for CA .....	599
7.7.1B	Minimum requirements for UL-MIMO .....	600
7.7.1D	Minimum requirements for ProSe .....	600
7.7.1F	Minimum requirements for UE category NB1 and NB2 .....	601
7.7.1G	Minimum requirements for V2X .....	601
7.8	Intermodulation characteristics .....	602
7.8.1	Wide band intermodulation .....	602
7.8.1.1	Minimum requirements .....	602
7.8.1A	Minimum requirements for CA .....	603
7.8.1B	Minimum requirements for UL-MIMO .....	606
7.8.1D	Minimum requirements for ProSe .....	606
7.8.1F	Minimum requirements for category NB1 and NB2 .....	607
7.8.1G	Minimum requirements .....	607
7.8.2	Void .....	608
7.9	Spurious emissions .....	608
7.9.1	Minimum requirements .....	609
7.9.1A	Minimum requirements .....	609
7.10	Receiver image .....	610
7.10.1	Void .....	610
7.10.1A	Minimum requirements for CA .....	610
7.10.1G	Minimum requirements for V2X Communication .....	610
8	Performance requirement .....	611
8.1	General .....	611

8.1.1	Receiver antenna capability .....	611
8.1.1.1	Simultaneous unicast and MBMS operations.....	612
8.1.1.2	Dual-antenna receiver capability in idle mode.....	612
8.1.2	Applicability of requirements .....	612
8.1.2.1	Applicability of requirements for different channel bandwidths.....	612
8.1.2.2	Definition of CA capability.....	612
8.1.2.2A	Definition of dual connectivity capability.....	617
8.1.2.3	Applicability and test rules for different CA configurations and bandwidth combination sets.....	618
8.1.2.3A	Applicability and test rules for different dual connectivity configuration and bandwidth combination set .....	620
8.1.2.3B	Applicability and test rules for different TDD-FDD CA configurations and bandwidth combination sets.....	621
8.1.2.3C	Applicability and test rules for SDR tests for 4Rx capable UEs .....	623
8.1.2.3D	Applicability and test rules for different CA with LAA SCell(s) configurations and bandwidth combination sets.....	623
8.1.2.3E	Applicability and test rules for SDR tests for 8Rx capable UEs .....	624
8.1.2.4	Test coverage for different number of component carriers .....	625
8.1.2.5	Applicability of performance requirements for Type B receiver .....	626
8.1.2.6	Applicability of performance requirements for 4Rx capable UEs .....	626
8.1.2.6.1	Applicability rule and antenna connection for single carrier tests with 2Rx .....	626
8.1.2.6.2	Applicability rule and antenna connection for CA and DC tests with 2Rx .....	628
8.1.2.6.3	Applicability rule and antenna connection for single carrier tests with 4Rx .....	628
8.1.2.6.4	Applicability rule for 256QAM tests .....	629
8.1.2.6.5	Applicability rule and antenna connection for CA and DC tests with 4Rx .....	629
8.1.2.6.6	Applicability rule for Type C with 4Rx.....	633
8.1.2.6.7	Applicability rule for 1024QAM tests .....	633
8.1.2.7	Applicability of Enhanced Downlink Control Channel Performance Requirements .....	633
8.1.2.8	Applicability of performance requirements for CDM-multiplexed DM RS with interfering simultaneous transmission (FRC) with multiple CSI-RS configurations.....	635
8.1.2.8A	Applicability of performance requirements for UE supporting coverage enhancement .....	635
8.1.2.9	Applicability of SDR requirements for CA and LAA .....	636
8.1.2.10	Applicability of performance requirements for Multi-user Superposed Transmission .....	637
8.1.2.11	Applicability CRS interference mitigation receivers performance requirements.....	637
8.1.2.12	Applicability of performance requirements for 8Rx capable UEs .....	638
8.1.2.12.1	Applicability rule and antenna connection for single carrier PDSCH tests .....	638
8.1.2.12.2	Applicability rule and antenna connection for control channel tests .....	644
8.1.2.12.3	Applicability rule and antenna connection for CA and DC tests .....	644
8.1.3	UE category and UE DL category .....	645
8.2	Demodulation of PDSCH (Cell-Specific Reference Symbols) .....	645
8.2.1	FDD (Fixed Reference Channel) .....	645
8.2.1.1	Single-antenna port performance .....	646
8.2.1.1.1	Minimum Requirement .....	646
8.2.1.1.2	Void .....	652
8.2.1.1.3	Void .....	652
8.2.1.1.4	Minimum Requirement 1 PRB allocation in presence of MBSFN.....	652
8.2.1.1.4A	Minimum Requirement 1 PRB allocation in presence of FeMBMS Unicast-mixed Cell under CA .....	652
8.2.1.2	Transmit diversity performance .....	653
8.2.1.2.1	Minimum Requirement 2 Tx Antenna Port .....	653
8.2.1.2.2	Minimum Requirement 4 Tx Antenna Port .....	654
8.2.1.2.3	Minimum Requirement 2 Tx Antenna Port (demodulation subframe overlaps with aggressor cell ABS) .....	654
8.2.1.2.3A	Minimum Requirement 2 Tx Antenna Ports (demodulation subframe overlaps with aggressor cell ABS and CRS assistance information are configured) .....	656
8.2.1.2.4	Enhanced Performance Requirement Type A - 2 Tx Antenna Ports with TM3 interference model .....	658
8.2.1.2.5	Enhanced Performance Requirement Type B - 2 Tx Antenna Ports with TM2 interference model .....	660
8.2.1.2.6	Enhanced Performance Requirement Type B - 2 Tx Antenna Ports with TM9 interference model .....	661
8.2.1.2.7	Minimum Requirement 2 Tx Antenna Port (Superposed transmission) .....	662
8.2.1.3	Open-loop spatial multiplexing performance .....	662

8.2.1.3.1	Minimum Requirement 2 Tx Antenna Port .....	662
8.2.1.3.1A	Soft buffer management test .....	666
8.2.1.3.1B	Enhanced Performance Requirement Type C –2Tx Antenna Ports .....	667
8.2.1.3.1C	Enhanced Performance Requirement Type C - 2 Tx Antenna Ports with TM1 interference .....	668
8.2.1.3.2	Minimum Requirement 4 Tx Antenna Port .....	669
8.2.1.3.3	Minimum Requirement 2 Tx Antenna Port (demodulation subframe overlaps with aggressor cell ABS) .....	669
8.2.1.3.4	Minimum Requirement 2 Tx Antenna Port (demodulation subframe overlaps with aggressor cell ABS and CRS assistance information are configured) .....	673
8.2.1.3.5	Minimum Requirement 2 Tx Antenna Port (Superposed transmission) .....	675
8.2.1.3.6	Minimum Requirement 2 Tx Antenna Port (network-based CRS interference mitigation).....	676
8.2.1.4	Closed-loop spatial multiplexing performance .....	677
8.2.1.4.1	Minimum Requirement Single-Layer Spatial Multiplexing 2 Tx Antenna Port .....	677
8.2.1.4.1A	Minimum Requirement Single-Layer Spatial Multiplexing 4 Tx Antenna Port .....	678
8.2.1.4.1B	Enhanced Performance Requirement Type A - Single-Layer Spatial Multiplexing 2 Tx Antenna Port with TM4 interference model .....	678
8.2.1.4.1C	Minimum Requirement Single-Layer Spatial Multiplexing 2 Tx Antenna Ports (demodulation subframe overlaps with aggressor cell ABS and CRS assistance information are configured)....	680
8.2.1.4.1D	Enhanced Performance Requirement Type B - Single-layer Spatial Multiplexing 2 Tx Antenna Port with TM4 interference model .....	683
8.2.1.4.1E	Minimum Requirement Single-Layer Spatial Multiplexing 2 Tx Antenna Ports with CRS assistance information .....	685
8.2.1.4.1F	Minimum Requirement Single-Layer Spatial Multiplexing 4 Tx Antenna Ports with CRS assistance information .....	686
8.2.1.4.2	Minimum Requirement Multi-Layer Spatial Multiplexing 2 Tx Antenna Port .....	687
8.2.1.4.2A	Enhanced Performance Requirement Type C – Multi-layer Spatial Multiplexing 2Tx Antenna Ports.....	688
8.2.1.4.3	Minimum Requirement Multi-Layer Spatial Multiplexing 4 Tx Antenna Port .....	688
8.2.1.4.3A	Minimum Requirement Multi-Layer Spatial Multiplexing 4 Tx Antenna Port for dual connectivity .....	692
8.2.1.4.4	Minimum Requirement Multi-Layer Spatial Multiplexing 2 Tx Antenna Port (Superposed transmission) .....	694
8.2.1.5	MU-MIMO .....	695
8.2.1.6	[Control channel performance: D-BCH and PCH] .....	695
8.2.1.7	Carrier aggregation with power imbalance .....	695
8.2.1.7.1	Minimum Requirement .....	695
8.2.1.8	Intra-band non-contiguous carrier aggregation with timing offset.....	696
8.2.1.8.1	Minimum Requirement .....	696
8.2.1.9	HST-SFN performance .....	697
8.2.1.9.1	Minimum Requirement .....	697
8.2.1.9.2	Minimum Requirement for Rel-16 further enhanced HST .....	700
8.2.1.10	Intra-band contiguous carrier aggregation with minimum channel spacing.....	700
8.2.1.10.1	Minimum Requirement .....	701
8.2.2	TDD (Fixed Reference Channel).....	701
8.2.2.1	Single-antenna port performance .....	702
8.2.2.1.1	Minimum Requirement .....	702
8.2.2.1.2	Void .....	707
8.2.2.1.3	Void .....	707
8.2.2.1.4	Minimum Requirement 1 PRB allocation in presence of MBSFN .....	707
8.2.2.2	Transmit diversity performance .....	707
8.2.2.2.1	Minimum Requirement 2 Tx Antenna Port .....	707
8.2.2.2.2	Minimum Requirement 4 Tx Antenna Port .....	708
8.2.2.2.3	Minimum Requirement 2 Tx Antenna Port (demodulation subframe overlaps with aggressor cell ABS) .....	709
8.2.2.2.3A	Minimum Requirement 2 Tx Antenna Ports (demodulation subframe overlaps with aggressor cell ABS and CRS assistance information are configured) .....	710
8.2.2.2.4	Enhanced Performance Requirement Type A – 2 Tx Antenna Ports with TM3 interference model .....	712
8.2.2.2.5	Minimum Requirement 2 Tx Antenna Port (when <i>EIMTA-MainConfigServCell-r12</i> is configured) .....	714
8.2.2.2.6	Enhanced Performance Requirement Type B - 2 Tx Antenna Ports with TM2 interference model .....	714

8.2.2.2.7	Enhanced Performance Requirement Type B - 2 Tx Antenna Ports with TM9 interference model .....	716
8.2.2.2.8	Minimum Requirement 2 Tx Antenna Port (Superposed transmission) .....	717
8.2.2.3	Open-loop spatial multiplexing performance .....	718
8.2.2.3.1	Minimum Requirement 2 Tx Antenna Port .....	718
8.2.2.3.1A	Soft buffer management test .....	721
8.2.2.3.1B	Enhanced Performance Requirement Type C - 2Tx Antenna Ports .....	721
8.2.2.3.1C	Enhanced Performance Requirement Type C - 2 Tx Antenna Ports with TM1 interference .....	722
8.2.2.3.2	Minimum Requirement 4 Tx Antenna Port .....	723
8.2.2.3.3	Minimum Requirement 2Tx antenna port (demodulation subframe overlaps with aggressor cell ABS) .....	724
8.2.2.3.4	Minimum Requirement 2 Tx Antenna Port (demodulation subframe overlaps with aggressor cell ABS and CRS assistance information are configured) .....	728
8.2.2.3.5	Minimum Requirement 2 Tx Antenna Port (Superposed transmission) .....	730
8.2.2.3.6	Minimum Requirement 2 Tx Antenna Port (network-based CRS interference mitigation).....	731
8.2.2.4	Closed-loop spatial multiplexing performance .....	732
8.2.2.4.1	Minimum Requirement Single-Layer Spatial Multiplexing 2 Tx Antenna Port .....	732
8.2.2.4.1A	Minimum Requirement Single-Layer Spatial Multiplexing 4 Tx Antenna Port .....	733
8.2.2.4.1B	Enhanced Performance Requirement Type A – Single-Layer Spatial Multiplexing 2 Tx Antenna Port with TM4 interference model .....	733
8.2.2.4.1C	Minimum Requirement Single-Layer Spatial Multiplexing 2 Tx Antenna Ports (demodulation subframe overlaps with aggressor cell ABS and CRS assistance information are configured) .....	735
8.2.2.4.1D	Enhanced Performance Requirement Type B – Single-layer Spatial Multiplexing 2 Tx Antenna Port with TM4 interference model .....	737
8.2.2.4.1E	Minimum Requirement Single-Layer Spatial Multiplexing 2 Tx Antenna Ports with CRS assistance information .....	739
8.2.2.4.1F	Minimum Requirement Single-Layer Spatial Multiplexing 4 Tx Antenna Ports with CRS assistance information .....	740
8.2.2.4.2	Minimum Requirement Multi-Layer Spatial Multiplexing 2 Tx Antenna Port .....	742
8.2.2.4.2A	Enhanced Performance Requirement Type C Multi-Layer Spatial Multiplexing 2 Tx Antenna Port .....	742
8.2.2.4.3	Minimum Requirement Multi-Layer Spatial Multiplexing 4 Tx Antenna Port .....	743
8.2.2.4.3A	Minimum Requirement Multi-Layer Spatial Multiplexing 4 Tx Antenna Port for dual connectivity .....	747
8.2.2.4.4	Void .....	748
8.2.2.4.5	Minimum Requirement Multi-Layer Spatial Multiplexing 2 Tx Antenna Port (Superposed transmission) .....	748
8.2.2.5	MU-MIMO .....	749
8.2.2.6	[Control channel performance: D-BCH and PCH] .....	749
8.2.2.7	Carrier aggregation with power imbalance .....	749
8.2.2.7.1	Minimum Requirement .....	749
8.2.2.8	Intra-band contiguous carrier aggregation with minimum channel spacing .....	750
8.2.2.8.1	Minimum Requirement .....	750
8.2.2.9	HST-SFN performance .....	751
8.2.2.9.1	Minimum Requirement .....	751
8.2.2.9.2	Minimum Requirement for Rel-16 further enhanced HST .....	753
8.2.3	TDD FDD CA (Fixed Reference Channel) .....	754
8.2.3.1	Single-antenna port performance .....	755
8.2.3.1.1	Minimum Requirement for FDD PCell .....	755
8.2.3.1.2	Minimum Requirement for TDD PCell .....	759
8.2.3.2	Open-loop spatial multiplexing performance 2Tx Antenna port.....	763
8.2.3.2.1	Minimum Requirement for FDD PCell .....	763
8.2.3.2.1A	Soft buffer management test for FDD PCell .....	767
8.2.3.2.2	Minimum Requirement for TDD PCell .....	768
8.2.3.2.2A	Soft buffer management test for TDD PCell .....	772
8.2.3.3	Closed-loop spatial multiplexing performance 4Tx Antenna Port .....	773
8.2.3.3.1	Minimum Requirement for FDD PCell .....	773
8.2.3.3.2	Minimum Requirement for TDD PCell .....	777
8.2.3.4	Minimum Requirement for Closed-loop spatial multiplexing performance 4Tx Antenna Port for dual connectivity .....	781
8.2.3.5	HST-SFN performance .....	783
8.2.3.5.0	General .....	783

8.2.3.5.1	Minimum Requirement for FDD PCell .....	783
8.2.3.5.2	Minimum Requirement for TDD PCell .....	786
8.2.4	LAA .....	789
8.2.4.1	Closed-loop spatial multiplexing performance 4Tx Antenna Port .....	789
8.2.4.1.1	FDD PCell (FDD single carrier) .....	789
8.2.4.1.2	TDD PCell (TDD single carrier) .....	793
8.3	Demodulation of PDSCH (User-Specific Reference Symbols) .....	796
8.3.1	FDD .....	796
8.3.1.1	Single-layer Spatial Multiplexing .....	797
8.3.1.1A	Enhanced Performance Requirement Type A – Single-layer Spatial Multiplexing with TM9 interference model .....	799
8.3.1.1B	Single-layer Spatial Multiplexing (demodulation subframe overlaps with aggressor cell ABS and CRS assistance information are configured) .....	802
8.3.1.1C	Enhanced Performance Requirement Type B – Single-layer Spatial Multiplexing with TM9 interference model .....	805
8.3.1.1D	Enhanced Performance Requirement Type B – Single-layer Spatial Multiplexing with CRS interference model .....	807
8.3.1.1E	Enhanced Performance Requirement Type B – Single-layer Spatial Multiplexing with TM3 interference model .....	808
8.3.1.1F	Enhanced Performance Requirement Type B – Single-layer Spatial Multiplexing with TM10 serving cell configuration and TM9 interference model .....	809
8.3.1.1G	Single-layer Spatial Multiplexing (CRS assistance information is configured) .....	811
8.3.1.1H	Single-layer Spatial Multiplexing (With Enhanced DMRS table configured) .....	813
8.3.1.1I	Single-layer Spatial Multiplexing (with assistance information for simultaneous transmission interfering PDSCH) .....	814
8.3.1.2	Dual-Layer Spatial Multiplexing .....	816
8.3.1.2A	Enhanced Performance Requirement Type C - Dual-Layer Spatial Multiplexing .....	817
8.3.1.3	Performance requirements for DCI format 2D and non Quasi Co-located Antenna Ports .....	818
8.3.1.3.1	Minimum requirement with Same Cell ID (with single NZP CSI-RS resource) .....	818
8.3.1.3.2	Minimum requirements with Same Cell ID (with multiple NZP CSI-RS resources) .....	820
8.3.1.3.3	Minimum requirement with Different Cell ID and Colliding CRS (with single NZP CSI-RS resource) .....	822
8.3.1.3.4	Minimum requirement with Different Cell ID and non-colliding CRS (with single NZP CSI- RS resource and CRS assistance information is configured) .....	824
8.3.1.3.5	Minimum requirements with different Cell ID and non-colliding CRS (with multiple NZP CSI-RS resources and CRS assistance information is configured) .....	826
8.3.1.3.6	Minimum requirements for QCL Type C and 2 Layers Spatial Multiplexing .....	829
8.3.1.4	Performance Requirements for semiOpenLoop transmission .....	831
8.3.2	TDD .....	833
8.3.2.1	Single-layer Spatial Multiplexing .....	833
8.3.2.1A	Single-layer Spatial Multiplexing (with multiple CSI-RS configurations) .....	835
8.3.2.1B	Enhanced Performance Requirement Type A – Single-layer Spatial Multiplexing with TM9 interference model .....	837
8.3.2.1C	Single-layer Spatial Multiplexing (demodulation subframe overlaps with aggressor cell ABS and CRS assistance information are configured) .....	840
8.3.2.1D	Enhanced Performance Requirement Type B – Single-layer Spatial Multiplexing with TM9 interference .....	843
8.3.2.1E	Enhanced Performance Requirement Type B – Single-layer Spatial Multiplexing with CRS interference model .....	845
8.3.2.1F	Enhanced Performance Requirement Type B – Single-layer Spatial Multiplexing with TM3 interference .....	847
8.3.2.1G	Enhanced Performance Requirement Type B – Single-layer Spatial Multiplexing with TM10 serving cell configuration and TM9 interference model .....	848
8.3.2.1H	Single-layer Spatial Multiplexing (CRS assistance information is configured) .....	850
8.3.2.1I	Single-layer Spatial Multiplexing (With Enhanced DMRS table configured) .....	852
8.3.2.1J	Single-layer Spatial Multiplexing (with assistance information for simultaneous transmission interfering PDSCH) .....	853
8.3.2.2	Dual-Layer Spatial Multiplexing .....	855
8.3.2.2A	Enhanced Performance Requirement Type C - Dual-Layer Spatial Multiplexing .....	855
8.3.2.3	Dual-Layer Spatial Multiplexing (with multiple CSI-RS configurations) .....	856
8.3.2.4	Performance requirements for DCI format 2D and non Quasi Co-located Antenna Ports .....	857
8.3.2.4.1	Minimum requirement with Same Cell ID (with single NZP CSI-RS resource) .....	857

8.3.2.4.2	Minimum requirements with Same Cell ID (with multiple NZP CSI-RS resources)	859
8.3.2.4.3	Minimum requirement with Different Cell ID and Colliding CRS (with single NZP CSI-RS resource)	861
8.3.2.4.4	Minimum requirement with Different Cell ID and non-Colliding CRS (with single NZP CSI-RS resource and CRS assistance information is configured)	863
8.3.2.4.5	Minimum requirements with different Cell ID and non-colliding CRS (with multiple NZP CSI-RS resources and CRS assistance information is configured)	865
8.3.2.4.6	Minimum requirements for QCL Type C and 2 Layers Spatial Multiplexing	868
8.3.2.5	Performance Requirements for semiOpenLoop transmission	870
8.3.3	LAA	872
8.3.3.1	Dual-Layer Spatial Multiplexing with DM-RS	872
8.3.3.1.1	FDD Pcell (FDD single carrier)	872
8.3.3.1.2	TDD Pcell (TDD single carrier)	877
8.4	Demodulation of PDCCH/PCFICH	881
8.4.1	FDD	881
8.4.1.1	Single-antenna port performance	882
8.4.1.2	Transmit diversity performance	882
8.4.1.2.1	Minimum Requirement 2 Tx Antenna Port	882
8.4.1.2.2	Minimum Requirement 4 Tx Antenna Port	882
8.4.1.2.3	Minimum Requirement 2 Tx Antenna Port (demodulation subframe overlaps with aggressor cell ABS)	883
8.4.1.2.4	Minimum Requirement 2 Tx Antenna Port (demodulation subframe overlaps with aggressor cell ABS and CRS assistance information are configured)	888
8.4.1.2.5	Enhanced Downlink Control Channel Performance Requirement Type A - 2 Tx Antenna Port under Asynchronous Network	894
8.4.1.2.6	Enhanced Downlink Control Channel Performance Requirement Type A - 2 Tx Antenna Port with Non-Colliding CRS Dominant Interferer	895
8.4.1.2.7	Enhanced Downlink Control Channel Performance Requirement Type B - 2 Tx Antenna Port with Colliding CRS Dominant Interferer	896
8.4.1.2.8	Enhanced Downlink Control Channel Performance Requirement Type B - 2 Tx Antenna Port with Non-Colliding CRS Dominant Interferer	897
8.4.1.2.9	Enhanced Downlink Control Channel Performance Requirement Type A - 4 Tx Antenna Port with Non-Colliding CRS Dominant Interferer	898
8.4.2	TDD	899
8.4.2.1	Single-antenna port performance	900
8.4.2.2	Transmit diversity performance	900
8.4.2.2.1	Minimum Requirement 2 Tx Antenna Port	900
8.4.2.2.2	Minimum Requirement 4 Tx Antenna Port	901
8.4.2.2.3	Minimum Requirement 2 Tx Antenna Port (demodulation subframe overlaps with aggressor cell ABS)	901
8.4.2.2.4	Minimum Requirement 2 Tx Antenna Port (demodulation subframe overlaps with aggressor cell ABS and CRS assistance information are configured)	905
8.4.2.2.5	Enhanced Downlink Control Channel Performance Requirement Type A - 2 Tx Antenna Port with Colliding CRS Dominant Interferer	909
8.4.2.2.6	Enhanced Downlink Control Channel Performance Requirement Type A - 2 Tx Antenna Port with Non-Colliding CRS Dominant Interferer	910
8.4.2.2.7	Enhanced Downlink Control Channel Performance Requirement Type B - 2 Tx Antenna Port with Colliding CRS Dominant Interferer	911
8.4.2.2.8	Enhanced Downlink Control Channel Performance Requirement Type B - 2 Tx Antenna Port with Non-Colliding CRS Dominant Interferer	912
8.4.2.2.9	Enhanced Downlink Control Channel Performance Requirement Type A - 4 Tx Antenna Port with Non-Colliding CRS Dominant Interferer	913
8.4.3	LAA	914
8.4.3.1	Transmit diversity performance	914
8.4.3.1.1	FDD Pcell (FDD single carrier)	914
8.4.3.1.2	TDD Pcell (TDD single carrier)	915
8.5	Demodulation of PHICH	916
8.5.1	FDD	917
8.5.1.1	Single-antenna port performance	917
8.5.1.2	Transmit diversity performance	917
8.5.1.2.1	Minimum Requirement 2 Tx Antenna Port	917
8.5.1.2.2	Minimum Requirement 4 Tx Antenna Port	918

8.5.1.2.3	Minimum Requirement 2 Tx Antenna Port (demodulation subframe overlaps with aggressor cell ABS) .....	918
8.5.1.2.4	Minimum Requirement 2 Tx Antenna Port (demodulation subframe overlaps with aggressor cell ABS and CRS assistance information are configured) .....	920
8.5.1.2.5	Enhanced Downlink Control Channel Performance Requirement Type A - 2 Tx Antenna Ports under Asynchronous Network .....	923
8.5.1.2.6	Enhanced Downlink Control Channel Performance Requirement Type A - 2 Tx Antenna Ports with Non-Colliding CRS Dominant Interferer .....	924
8.5.1.2.7	Enhanced Downlink Control Channel Performance Requirement Type B - 2 Tx Antenna Ports with Colliding CRS Dominant Interferer .....	925
8.5.1.2.8	Enhanced Downlink Control Channel Performance Requirement Type B - 2 Tx Antenna Ports with Non-Colliding CRS Dominant Interferer .....	926
8.5.2	TDD .....	927
8.5.2.1	Single-antenna port performance .....	928
8.5.2.2	Transmit diversity performance .....	928
8.5.2.2.1	Minimum Requirement 2 Tx Antenna Port .....	928
8.5.2.2.2	Minimum Requirement 4 Tx Antenna Port .....	929
8.5.2.2.3	Minimum Requirement 2 Tx Antenna Port (demodulation subframe overlaps with aggressor cell ABS) .....	929
8.5.2.2.4	Minimum Requirement 2 Tx Antenna Port (demodulation subframe overlaps with aggressor cell ABS and CRS assistance information are configured) .....	931
8.5.2.2.5	Enhanced Downlink Control Channel Performance Requirement Type A - 2 Tx Antenna Ports with Colliding CRS Dominant Interferer .....	933
8.5.2.2.6	Enhanced Downlink Control Channel Performance Requirement Type A - 2 Tx Antenna Ports with Non-Colliding CRS Dominant Interferer .....	934
8.5.2.2.7	Enhanced Downlink Control Channel Performance Requirement Type B - 2 Tx Antenna Ports with Colliding CRS Dominant Interferer .....	935
8.5.2.2.8	Enhanced Downlink Control Channel Performance Requirement Type B - 2 Tx Antenna Ports with Non-Colliding CRS Dominant Interferer .....	936
8.6	Demodulation of PBCH .....	937
8.6.1	FDD .....	937
8.6.1.1	Single-antenna port performance .....	937
8.6.1.2	Transmit diversity performance .....	938
8.6.1.2.1	Minimum Requirement 2 Tx Antenna Port .....	938
8.6.1.2.2	Minimum Requirement 4 Tx Antenna Port .....	938
8.6.1.2.3	Minimum Requirement 2 Tx Antenna Port under Time Domain Measurement Resource Restriction with CRS Assistance Information .....	938
8.6.2	TDD .....	940
8.6.2.1	Single-antenna port performance .....	940
8.6.2.2	Transmit diversity performance .....	940
8.6.2.2.1	Minimum Requirement 2 Tx Antenna Port .....	940
8.6.2.2.2	Minimum Requirement 4 Tx Antenna Port .....	940
8.6.2.2.3	Minimum Requirement 2 Tx Antenna Port under Time Domain Measurement Resource Restriction with CRS Assistance Information .....	941
8.7	Sustained downlink data rate provided by lower layers .....	942
8.7.1	FDD (single carrier and CA) .....	942
8.7.2	TDD (single carrier and CA) .....	959
8.7.3	FDD (EPDCCH scheduling) .....	963
8.7.4	TDD (EPDCCH scheduling) .....	965
8.7.5	TDD FDD CA .....	967
8.7.5.1	Minimum Requirement FDD PCell .....	968
8.7.5.2	Minimum Requirement TDD PCell .....	976
8.7.6	FDD (DC) .....	985
8.7.7	TDD (DC) .....	992
8.7.8	TDD FDD (DC) .....	995
8.7.9	FDD (4 Rx) .....	998
8.7.10	TDD (4 Rx) .....	1000
8.7.11	TDD FDD CA (4 Rx) .....	1002
8.7.11.1	Void .....	1004
8.7.12	LAA .....	1004
8.7.12.1	FDD CA in licensed bands .....	1004
8.7.12.2	TDD CA in licensed bands .....	1006



8.7.12.3	TDD-FDD CA in licensed bands .....	1008
8.7.13	FDD DC (4 Rx) .....	1011
8.7.14	TDD DC (4 Rx) .....	1012
8.7.15	TDD FDD DC (4 Rx) .....	1014
8.7.16	FDD (1024QAM and up to 4Rx supported) .....	1016
8.7.17	TDD (1024QAM and up to 4 Rx supported) .....	1019
8.7.18	TDD FDD CA (1024QAM and up to 4 Rx supported).....	1021
8.7.19	TDD (8 Rx).....	1023
8.8	Demodulation of EPDCCH .....	1025
8.8.1	Distributed Transmission .....	1025
8.8.1.1	FDD.....	1025
8.8.1.1.1	Void .....	1026
8.8.1.2	TDD .....	1026
8.8.1.2.1	Void .....	1027
8.8.2	Localized Transmission with TM9 .....	1027
8.8.2.1	FDD.....	1027
8.8.2.1.1	Void .....	1028
8.8.2.1.2	Void .....	1029
8.8.2.2	TDD .....	1029
8.8.2.2.1	Void .....	1030
8.8.2.2.2	Void .....	1030
8.8.3	Localized transmission with TM10 Type B quasi co-location type.....	1030
8.8.3.1	FDD.....	1030
8.8.3.2	TDD .....	1033
8.8.4	Enhanced Downlink Control Channel Performance Requirements Type A - Localized Transmission with CRS Interference Model .....	1036
8.8.4.1	FDD.....	1036
8.8.4.2	TDD .....	1037
8.8.5	Enhanced Downlink Control Channel Performance Requirements Type A - Distributed Transmission with TM9 Interference Model .....	1039
8.8.5.1	TDD .....	1039
8.8.6	Enhanced Downlink Control Channel Performance Requirements Type A - Distributed Transmission with TM3 Interference Model .....	1040
8.8.6.1	FDD.....	1040
8.9	Demodulation (single receiver antenna) .....	1041
8.9.1	PDSCH .....	1041
8.9.1.1	FDD and half-duplex FDD (Fixed Reference Channel).....	1041
8.9.1.1.1	Transmit diversity performance (Cell-Specific Reference Symbols) .....	1041
8.9.1.1.2	Closed-loop spatial multiplexing performance (Cell-Specific Reference Symbols) .....	1042
8.9.1.1.3	Closed-loop spatial multiplexing performance (User-Specific Reference Symbols) .....	1044
8.9.1.2	TDD (Fixed Reference Channel) .....	1047
8.9.1.2.1	Transmit diversity performance (Cell-Specific Reference Symbols) .....	1047
8.9.1.2.2	Closed-loop spatial multiplexing performance (Cell-Specific Reference Symbols) .....	1048
8.9.1.2.3	Closed-loop spatial multiplexing performance (User-Specific Reference Symbols) .....	1051
8.9.2	PHICH .....	1053
8.9.2.1	FDD and half-duplex FDD.....	1053
8.9.2.1.1	Transmit diversity performance .....	1053
8.9.2.2	TDD .....	1053
8.9.2.2.1	Transmit diversity performance.....	1053
8.9.3	PBCH.....	1054
8.9.3.1	FDD and half-duplex FDD.....	1054
8.9.3.1.1	Transmit diversity performance .....	1054
8.9.3.2	TDD .....	1054
8.9.3.2.1	Transmit diversity performance.....	1054
8.9.4	PDCCCH/PCFICH .....	1054
8.9.4.1	FDD and half-duplex FDD.....	1054
8.9.4.1.1	Enhanced Downlink Control Channel Performance Requirement Type A - 2 Tx Antenna Port with Non-Colliding CRS Dominant Interferer .....	1054
8.9.4.1.2	Enhanced Downlink Control Channel Performance Requirement Type A - 4 Tx Antenna Port with Non-Colliding CRS Dominant Interferer .....	1055
8.9.4.2	TDD .....	1056

8.9.4.2.1	Enhanced Downlink Control Channel Performance Requirement Type A - 2 Tx Antenna Port with Non-Colliding CRS Dominant Interferer .....	1056
8.9.4.2.2	Enhanced Downlink Control Channel Performance Requirement Type A - 4 Tx Antenna Port with Non-Colliding CRS Dominant Interferer .....	1057
8.10	Demodulation (4 receiver antenna ports) .....	1058
8.10.1	PDSCH .....	1058
8.10.1.1	FDD (Fixed Reference Channel) .....	1058
8.10.1.1.1	Transmit diversity performance with 2Tx Antenna Ports (Cell-Specific Reference Symbols) ...	1059
8.10.1.1.1A	Transmit diversity performance with Enhanced Performance Requirement Type A - 2 Tx Antenna Ports with TM3 interference model .....	1060
8.10.1.1.2	Open-loop spatial multiplexing performance with 2Tx Antenna Ports (Cell-Specific Reference Symbols) .....	1061
8.10.1.1.3	Closed-loop spatial multiplexing Enhanced Performance Requirements Type A - Single-Layer Spatial Multiplexing 2 Tx Antenna Port with TM4 interference model (Cell-Specific Reference Symbols) .....	1061
8.10.1.1.4	Closed-loop spatial multiplexing performance, Dual-Layer Spatial Multiplexing 4 Tx Antenna Port (Cell-Specific Reference Symbols) .....	1062
8.10.1.1.4A	Enhanced Performance Requirement Type C - Dual-Layer Spatial Multiplexing with 2Tx Antenna Ports .....	1063
8.10.1.1.5	Enhanced Performance Requirement Type A - Single-layer Spatial Multiplexing with TM9 interference model (User-Specific Reference Symbols) .....	1064
8.10.1.1.5A	Single-layer Spatial Multiplexing (User-Specific Reference Symbols) .....	1067
8.10.1.1.5B	Single-layer Spatial Multiplexing (With Enhanced DMRS table configured) .....	1068
8.10.1.1.6	Dual-Layer Spatial Multiplexing (User-Specific Reference Symbols) .....	1069
8.10.1.1.6A	Enhanced Performance Requirement Type C - Dual-Layer Spatial Multiplexing .....	1071
8.10.1.1.6B	Dual-Layer Spatial Multiplexing with altCQI-Table-1024QAM configured (User-Specific Reference Symbols) .....	1072
8.10.1.1.7	Open-loop spatial multiplexing, 3 Layer Multiplexing with 4 Tx Antenna Ports (Cell-Specific Reference Symbols) .....	1073
8.10.1.1.7A	Enhanced Performance Requirement Type C - Open-loop spatial multiplexing, 3 Layer Multiplexing with 4 Tx Antenna Ports (Cell-Specific Reference Symbols) .....	1073
8.10.1.1.8	Closed-loop spatial multiplexing performance, 4 Layers spatial multiplexing 4 Tx antennas (Cell-Specific Reference Symbols) .....	1074
8.10.1.1.9	4 Layer Spatial Multiplexing (User-Specific Reference Symbols) .....	1074
8.10.1.1.9A	Enhanced Performance Requirement Type C - 4 Layer Spatial Multiplexing (User-Specific Reference Symbols) .....	1076
8.10.1.1.10	Closed loop spatial multiplexing performance - Single-Layer Spatial Multiplexing 2 Tx Antenna Port with CRS assistance information (Cell-Specific Reference Symbols) .....	1077
8.10.1.1.11	Closed loop spatial multiplexing performance - Single-Layer Spatial Multiplexing 4 Tx Antenna Port with CRS assistance information (Cell-Specific Reference Symbols) .....	1078
8.10.1.1.12	Closed loop spatial multiplexing performance - Single-Layer Spatial Multiplexing with CRS assistance information (User-Specific Reference Symbols) .....	1079
8.10.1.1.13	Performance requirements for DCI format 2D and non Quasi Co-located Antenna Ports .....	1080
8.10.1.1.14	HST-SFN performance .....	1084
8.10.1.2	TDD (Fixed Reference Channel) .....	1084
8.10.1.2.1	Transmit diversity performance with 2Tx Antenna Ports (Cell-Specific Reference Symbols) ...	1085
8.10.1.2.1A	Transmit diversity performance with Enhanced Performance Requirement Type A - 2 Tx Antenna Ports with TM3 interference model .....	1086
8.10.1.2.2	Open-loop spatial multiplexing performance with 2Tx Antenna Ports (Cell-Specific Reference Symbols) .....	1087
8.10.1.2.3	Closed-loop spatial multiplexing Enhanced Performance Requirements Type A - Single-Layer Spatial Multiplexing 2 Tx Antenna Port with TM4 interference model (Cell-Specific Reference Symbols) .....	1087
8.10.1.2.4	Closed-loop spatial multiplexing performance, Dual-Layer Spatial Multiplexing 4 Tx Antenna Ports (Cell-Specific Reference Symbols) .....	1088
8.10.1.2.4A	Enhanced Performance Requirement Type C - Dual-Layer Spatial Multiplexing with 2Tx Antenna Ports .....	1089
8.10.1.2.5	Enhanced Performance Requirement Type A - Single-layer Spatial Multiplexing with TM9 interference model (User-Specific Reference Symbols) .....	1090
8.10.1.2.5A	Single-layer Spatial Multiplexing (with multiple CSI-RS configurations) .....	1093
8.10.1.2.5B	Single-layer Spatial Multiplexing (With Enhanced DMRS table configured) .....	1094
8.10.1.2.6	Dual-Layer Spatial Multiplexing (User-Specific Reference Symbols) .....	1095

8.10.1.2.6A	Enhanced Performance Requirement Type C - Dual-Layer Spatial Multiplexing .....	1097
8.10.1.2.6B	Dual-Layer Spatial Multiplexing with altCQI-Table-1024QAM configured (User-Specific Reference Symbols) .....	1098
8.10.1.2.7	Open-loop spatial multiplexing, 3 Layer Multiplexing with 4 Tx Antenna Ports (Cell-Specific Reference Symbols) .....	1099
8.10.1.2.7A	Enhanced Performance Requirement Type C - Open-loop spatial multiplexing, 3 Layer Multiplexing with 4 Tx Antenna Ports (Cell-Specific Reference Symbols) .....	1099
8.10.1.2.8	Closed-loop spatial multiplexing performance, 4 Layers spatial multiplexing 4 Tx antennas .....	1100
8.10.1.2.9	4 Layer Spatial Multiplexing (User-Specific Reference Symbols) .....	1101
8.10.1.2.9A	Enhanced Performance Requirement Type C - 4 Layer Spatial Multiplexing (User-Specific Reference Symbols) .....	1102
8.10.1.2.10	Closed loop spatial multiplexing performance - Single-Layer Spatial Multiplexing 2 Tx Antenna Port with CRS assistance information (Cell-Specific Reference Symbols) .....	1103
8.10.1.2.11	Closed loop spatial multiplexing performance - Single-Layer Spatial Multiplexing 4 Tx Antenna Port with CRS assistance information (Cell-Specific Reference Symbols) .....	1105
8.10.1.2.12	Closed loop spatial multiplexing performance - Single-Layer Spatial Multiplexing with CRS assistance information (User-Specific Reference Symbols) .....	1106
8.10.1.2.13	Performance requirements for DCI format 2D and non Quasi Co-located Antenna Ports .....	1108
8.10.1.2.14	HST-SFN performance .....	1112
8.10.2	PDCCH/PCFICH .....	1113
8.10.2.1	FDD .....	1113
8.10.2.1.1	Single-antenna port performance .....	1113
8.10.2.1.2	Transmit diversity performance with 2 Tx Antenna Ports .....	1113
8.10.2.1.3	Transmit diversity performance with 4 Tx Antenna Ports .....	1114
8.10.2.1.4	Enhanced Downlink Control Channel Performance Requirement Type A - 4 Tx Antenna Port with Non-Colliding CRS Dominant Interferer .....	1114
8.10.2.2	TDD .....	1116
8.10.2.2.1	Single-antenna port performance .....	1116
8.10.2.2.2	Transmit diversity performance with 2 Tx Antenna Ports .....	1116
8.10.2.2.3	Transmit diversity performance with 4 Tx Antenna Ports .....	1117
8.10.2.2.4	Enhanced Downlink Control Channel Performance Requirement Type A - 4 Tx Antenna Port with Non-Colliding CRS Dominant Interferer .....	1117
8.10.3	PHICH .....	1118
8.10.3.1	FDD .....	1118
8.10.3.1.1	Single Tx Antenna Port performance .....	1118
8.10.3.1.2	Transmit diversity performance with 2 Tx Antenna Ports .....	1119
8.10.3.1.3	Transmit diversity performance with 4 Tx Antenna Ports .....	1119
8.10.3.2	TDD .....	1119
8.10.3.2.1	Single Tx Antenna Port performance .....	1120
8.10.3.2.2	Transmit diversity performance with 2 Tx Antenna Ports .....	1120
8.10.3.2.3	Transmit diversity performance with 4 Tx Antenna Ports .....	1121
8.10.4	ePDCCH .....	1121
8.10.4.1	Distributed Transmission with 4Rx .....	1121
8.10.4.1.1	FDD .....	1121
8.10.4.1.2	TDD .....	1122
8.10.4.2	Localized Transmission with TM9 and 4Rx .....	1123
8.10.4.2.1	FDD .....	1123
8.10.4.2.2	TDD .....	1124
8.11	Demodulation (UE supporting coverage enhancement) .....	1125
8.11.1	PDSCH .....	1126
8.11.1.1	FDD and half-duplex FDD (Fixed Reference Channel) .....	1126
8.11.1.1.1	Closed-loop spatial multiplexing performance (Cell-Specific Reference Symbols) .....	1126
8.11.1.1.2	Closed-loop spatial multiplexing performance (User-Specific Reference Symbols) .....	1130
8.11.1.1.3	Transmit diversity performance (Cell-Specific Reference Symbols) .....	1132
8.11.1.2	TDD (Fixed Reference Channel) .....	1137
8.11.1.2.1	Closed-loop spatial multiplexing performance (Cell-Specific Reference Symbols) .....	1137
8.11.1.2.2	Closed-loop spatial multiplexing performance (User-Specific Reference Symbols) .....	1142
8.11.1.2.3	Transmit diversity performance (Cell-Specific Reference Symbols) .....	1144
8.11.2	MPDCCH .....	1148
8.11.2.1	FDD and half-duplex FDD .....	1149
8.11.2.1.1	CE Mode A .....	1150
8.11.2.1.2	CE Mode B .....	1151

8.11.2.1.3	CE Mode A with TM9 interference model .....	1151
8.11.2.1.4	CE Mode A with CRS interference model .....	1153
8.11.2.1.5	CE Mode A and CE Mode B when CRS-ChEstMPDCCH-Config is configured .....	1154
8.11.2.2.5	CE Mode A and CE Mode B when CRS-ChEstMPDCCH-Config is configured .....	1155
8.11.2.2	TDD .....	1157
8.11.2.2.1	CE Mode A .....	1158
8.11.2.2.2	CE Mode B .....	1159
8.11.2.2.3	CE Mode A with TM9 interference model .....	1159
8.11.2.2.4	CE Mode A with CRS interference model .....	1160
8.11.3	PBCH .....	1161
8.11.3.1	FDD and half-duplex FDD .....	1162
8.11.3.1.1	Transmit diversity performance .....	1162
8.11.3.2	TDD .....	1163
8.11.3.2.1	Transmit diversity performance .....	1163
8.12	Demodulation of Narrowband IoT .....	1163
8.12.1	NPDSCH .....	1163
8.12.1.1.1	Minimum Requirements for In-band .....	1164
8.12.1.1.2	Minimum Requirements for Standalone/Guard-band .....	1165
8.12.1.1.3	Minimum Requirements for Standalone for UE Category NB2 .....	1166
8.12.1.1.4	Minimum Requirements for Standalone for UE with multiple TBs interleaved transmission .....	1167
8.12.1.2	TDD .....	1168
8.12.1.2.1	Minimum Requirements for In-band .....	1168
8.12.1.2.2	Minimum Requirements for Standalone/Guard-band .....	1169
8.12.1.2.3	Minimum Requirements for Standalone for UE Category NB2 .....	1170
8.12.2	NPDCCH .....	1170
8.12.2.1	Half-duplex FDD .....	1170
8.12.2.1.1	Single-antenna performance .....	1171
8.12.2.1.2	Transmit diversity performance .....	1172
8.12.2.2	TDD .....	1172
8.12.2.2.1	Single-antenna performance .....	1174
8.12.2.2.2	Transmit diversity performance .....	1174
8.12.3	Demodulation of NPBCH .....	1174
8.12.3.1	HD-FDD .....	1175
8.12.3.1.1	Single-antenna port performance with single NPBCH TTI .....	1175
8.12.3.1.2	Transmit diversity performance .....	1175
8.12.3.2	TDD .....	1175
8.12.3.2.1	Single-antenna port performance with single NPBCH TTI .....	1176
8.12.3.2.2	Transmit diversity performance .....	1176
8.13	Demodulation of PDSCH CA and DC(4 receiver antenna ports) .....	1176
8.13.1	FDD (CA and DC) .....	1176
8.13.1.1	Closed-loop spatial multiplexing performance .....	1176
8.13.1.1.1	Minimum Requirement Multi-Layer Spatial Multiplexing 4 Tx Antenna Port .....	1176
8.13.1.1.2	Minimum Requirement Multi-Layer Spatial Multiplexing 4 Tx Antenna Port for dual connectivity .....	1180
8.13.1.1.3	Minimum Requirement Multi-Layer Spatial Multiplexing 4 Tx Antenna Port with 256QAM .....	1182
8.13.1.1.4	Minimum Requirement Four-Layer Spatial Multiplexing 4 Tx Antenna Port .....	1184
8.13.1.2	Dual-Layer Spatial Multiplexing (User-Specific Reference Symbols) .....	1185
8.13.1.2.1	Minimum Requirement Dual-Layer Spatial Multiplexing 2 Tx Antenna Port .....	1185
8.13.1.3	Enhanced Performance Requirements Type A Closed-loop spatial multiplexing .....	1188
8.13.1.3.1	Minimum Requirement Single-Layer Spatial Multiplexing 2 Tx Antenna Port with TM4 interference model (Cell-Specific Reference Symbols) .....	1188
8.13.1.4	Enhanced Performance Requirement Type A - Single-layer Spatial Multiplexing (User-Specific Reference Symbols) .....	1190
8.13.1.4.1	Minimum Requirement Enhanced Performance Requirement Type A – Single-layer Spatial Multiplexing with TM9 interference model (User-Specific Reference Symbols) .....	1190
8.13.2	TDD (CA and DC) .....	1193
8.13.2.1	Closed-loop spatial multiplexing performance .....	1194
8.13.2.1.1	Minimum Requirement Multi-Layer Spatial Multiplexing 4 Tx Antenna Port .....	1194
8.13.2.1.2	Minimum Requirement Multi-Layer Spatial Multiplexing 4 Tx Antenna Port for dual connectivity .....	1196
8.13.2.1.3	Minimum Requirement Multi-Layer Spatial Multiplexing 4 Tx Antenna Port with 256QAM .....	1197
8.13.2.1.4	Minimum Requirement Four-Layer Spatial Multiplexing 4 Tx Antenna Port .....	1198

8.13.2.2	Dual-Layer Spatial Multiplexing (User-Specific Reference Symbols) .....	1200
8.13.2.2.1	Minimum Requirement Dual-Layer Spatial Multiplexing 2 Tx Antenna Port .....	1200
8.13.2.4	Enhanced Performance Requirement Type A - Single-layer Spatial Multiplexing (User-Specific Reference Symbols) .....	1204
8.13.2.4.1	Minimum Requirement Enhanced Performance Requirement Type A – Single-layer Spatial Multiplexing with TM9 interference model (User-Specific Reference Symbols) .....	1204
8.13.3	TDD-FDD (CA and DC) .....	1206
8.13.3.1	Closed-loop spatial multiplexing performance 4Tx Antenna Port .....	1206
8.13.3.1.1	Minimum Requirement for FDD PCell .....	1206
8.13.3.1.2	Minimum Requirement for TDD PCell .....	1210
8.13.3.2	Dual-Layer Spatial Multiplexing (User-Specific Reference Symbols) .....	1214
8.13.3.2.1	Minimum Requirement Dual-Layer Spatial Multiplexing 2 Tx Antenna Port for FDD PCell .....	1214
8.13.3.2.2	Minimum Requirement Dual-Layer Spatial Multiplexing 2 Tx Antenna Port for TDD PCell .....	1217
8.13.3.3	Enhanced Performance Requirements Type A Closed-loop spatial multiplexing .....	1220
8.13.3.3.1	Minimum Requirement Single-Layer Spatial Multiplexing 2 Tx Antenna Port with TM4 interference model (Cell-Specific Reference Symbols) for FDD PCell .....	1220
8.13.3.3.2	Minimum Requirement Single-Layer Spatial Multiplexing 2 Tx Antenna Port with TM4 interference model (Cell-Specific Reference Symbols) for TDD PCell .....	1222
8.13.3.4	Enhanced Performance Requirement Type A - Single-layer Spatial Multiplexing (User-Specific Reference Symbols) .....	1224
8.13.3.4.1	Minimum Requirement Enhanced Performance Requirement Type A – Single-layer Spatial Multiplexing with TM9 interference model (User-Specific Reference Symbols) for FDD PCell .....	1224
8.13.3.4.2	Minimum Requirement Enhanced Performance Requirement Type A – Single-layer Spatial Multiplexing with TM9 interference model (User-Specific Reference Symbols) for TDD PCell .....	1227
8.13.3.5	Closed-loop spatial multiplexing performance 4Tx Antenna Port for DC .....	1230
8.13.3.5.1	Minimum Requirement for FDD PCell .....	1230
8.13.3.5.2	Minimum Requirement for TDD PCell .....	1232
8.13.3.6	Closed-loop spatial multiplexing performance 4Tx Antenna Port with 256QAM .....	1234
8.13.3.6.1	Minimum Requirement for FDD PCell .....	1234
8.13.3.6.2	Minimum Requirement for TDD PCell .....	1236
8.13.3.7	Closed-loop spatial multiplexing performance 4Tx Antenna Port with Four layers .....	1237
8.13.3.7.1	Minimum Requirement for FDD PCell .....	1237
8.13.3.7.2	Minimum Requirement for TDD PCell .....	1239
8.14	Demodulation (UE supporting Short TTI) .....	1241
8.14.1	Slot-PDSCH and Subslot-PDSCH .....	1241
8.14.1.1	FDD (Fixed Reference Channel) .....	1241
8.14.1.1.1	Open-loop spatial multiplexing performance .....	1241
8.14.1.1.2	Closed-loop spatial multiplexing performance (User-Specific Reference Signals) .....	1242
8.14.1.2	TDD (Fixed Reference Channel) .....	1244
8.14.1.2.1	Open-loop spatial multiplexing performance .....	1244
8.14.1.2.2	Closed-loop spatial multiplexing performance (User-Specific Reference Signals) .....	1245
8.14.2	SPDCCH .....	1246
8.14.2.1	FDD .....	1246
8.14.2.1.1	Minimum requirement .....	1247
8.14.2.2	TDD .....	1247
8.14.2.2.1	Minimum requirement .....	1248
8.15	Demodulation (8 receiver antenna ports) .....	1249
8.15.1	PDSCH .....	1249
8.15.1.1	Void .....	1249
8.15.1.2	TDD (Fixed Reference Channel) .....	1249
8.15.1.2.1	Transmit diversity performance with 2Tx Antenna Ports (Cell-Specific Reference Symbols) .....	1249
8.15.1.2.2	Open-loop spatial multiplexing performance with 2Tx Antenna Ports (Cell-Specific Reference Symbols) .....	1250
8.15.1.2.3	8 Layer Spatial Multiplexing (User-Specific Reference Symbols) .....	1250
8.15.2	CA .....	1252
8.15.2.1	Void .....	1252
8.15.2.2	TDD .....	1252
8.15.2.2.1	Eight Layer Spatial Multiplexing (User-Specific Reference Symbols) .....	1252
9	Reporting of Channel State Information .....	1254

9.1	General .....	1254
9.1.1	Applicability of requirements .....	1254
9.1.1.1	Applicability of requirements for different channel bandwidths.....	1254
9.1.1.2	Applicability and test rules for different CA configurations and bandwidth combination sets.....	1254
9.1.1.2A	Applicability and test rules for different TDD-FDD CA configurations and bandwidth combination sets.....	1255
9.1.1.3	Test coverage for different number of component carriers .....	1256
9.1.1.4	Applicability of performance requirements for 4Rx capable UEs .....	1256
9.1.1.4.1	Applicability rule and antenna connection for single carrier tests with 2Rx .....	1256
9.1.1.4.2	Applicability rule and antenna connection for CA tests with 2Rx .....	1258
9.1.1.4.3	Applicability rule and antenna connection for single carrier tests with 4Rx .....	1259
9.1.1.5	Applicability of requirements for UEs supporting coverage enhancement.....	1259
9.2	CQI reporting definition under AWGN conditions .....	1259
9.2.1	Minimum requirement PUCCH 1-0 (Cell-Specific Reference Symbols) .....	1259
9.2.1.1	FDD.....	1259
9.2.1.2	TDD .....	1260
9.2.1.3	FDD (CSI measurements in case two CSI subframe sets are configured) .....	1261
9.2.1.4	TDD (CSI measurements in case two CSI subframe sets are configured) .....	1264
9.2.1.5	FDD (CSI measurements in case two CSI subframe sets are configured and with CRS assistance information) .....	1267
9.2.1.6	TDD (CSI measurements in case two CSI subframe sets are configured and with CRS assistance information) .....	1270
9.2.1.7	FDD (Modulation and TBS index Table 2 and 4-bit CQI Table 2 are used) .....	1273
9.2.1.8	TDD (Modulation and TBS index Table 2 and 4-bit CQI Table 2 are used) .....	1274
9.2.1.9	FDD (Modulation and TBS index Table 3 and 4-bit CQI Table 4 are used) .....	1274
9.2.1.10	TDD (Modulation and TBS index Table 3 and 4-bit CQI Table 4 are used) .....	1275
9.2.2	Minimum requirement PUCCH 1-1 (Cell-Specific Reference Symbols) .....	1276
9.2.2.1	FDD.....	1276
9.2.2.2	TDD .....	1277
9.2.3	Minimum requirement PUCCH 1-1 (CSI Reference Symbols).....	1278
9.2.3.1	FDD.....	1278
9.2.3.1A	FDD (With <i>channelMeasRestriction</i> configured) .....	1279
9.2.3.2	TDD .....	1280
9.2.3.2A	TDD (With <i>channelMeasRestriction</i> configured) .....	1281
9.2.4	Minimum requirement PUCCH 1-1 (With Single CSI Process).....	1282
9.2.4.1	FDD.....	1283
9.2.4.1A	FDD (With <i>interferenceMeasRestriction</i> configured).....	1285
9.2.4.2	TDD .....	1288
9.2.4.2A	TDD (With <i>interferenceMeasRestriction</i> configured) .....	1291
9.2.5	Minimum requirement PUCCH 1-1 (when <i>csi-SubframeSet-r12</i> and <i>EIMTA-MainConfigServCell-r12</i> are configured) .....	1294
9.2.6	Minimum requirement PUSCH 3-0 (Cell-Specific Reference Symbols).....	1297
9.2.6.1	Frame structure type 3 with FDD Pcell .....	1297
9.2.6.2	Frame structure type 3 with TDD Pcell.....	1299
9.2.7	Minimum requirement PUSCH 3-1 (CSI Reference Symbol).....	1301
9.2.7.1	Frame structure type 3 with FDD Pcell .....	1301
9.2.7.2	Frame structure type 3 with TDD Pcell.....	1303
9.3	CQI reporting under fading conditions.....	1307
9.3.1	Frequency-selective scheduling mode .....	1307
9.3.1.1	Minimum requirement PUSCH 3-0 (Cell-Specific Reference Symbols).....	1307
9.3.1.1.1	FDD .....	1307
9.3.1.1.2	TDD.....	1308
9.3.1.1.3	FDD (CSI measurements in case two CSI subframe sets are configured and with CRS assistance information) .....	1309
9.3.1.1.4	TDD (CSI measurements in case two CSI subframe sets are configured and with CRS assistance information) .....	1313
9.3.1.1.5	TDD (when <i>csi-SubframeSet-r12</i> is configured) .....	1316
9.3.1.2	Minimum requirement PUSCH 3-1 (CSI Reference Symbol) .....	1318
9.3.1.2.1	FDD .....	1318
9.3.1.2.2	TDD.....	1319
9.3.1.2.3	FDD (Modulation and TBS index Table 2 and 4-bit CQI Table 2 are used).....	1321
9.3.1.2.4	TDD (Modulation and TBS index Table 2 and 4-bit CQI Table 2 are used).....	1322

9.3.1.2.5	Void	1323
9.3.1.2.6	TDD (when <i>csi-SubframeSet-r12</i> is configured with one CSI process)	1323
9.3.2	Frequency non-selective scheduling mode	1327
9.3.2.1	Minimum requirement PUCCH 1-0 (Cell-Specific Reference Symbol)	1327
9.3.2.1.1	FDD	1327
9.3.2.1.2	TDD	1329
9.3.2.2	Minimum requirement PUCCH 1-1 (CSI Reference Symbol)	1331
9.3.2.2.1	FDD	1331
9.3.2.2.2	TDD	1332
9.3.3	Frequency-selective interference	1334
9.3.3.1	Minimum requirement PUSCH 3-0 (Cell-Specific Reference Symbol)	1334
9.3.3.1.1	FDD	1334
9.3.3.1.2	TDD	1335
9.3.3.2	Void	1336
9.3.3.2.1	Void	1336
9.3.3.2.2	Void	1336
9.3.4	UE-selected subband CQI	1336
9.3.4.1	Minimum requirement PUSCH 2-0 (Cell-Specific Reference Symbols)	1336
9.3.4.1.1	FDD	1336
9.3.4.1.2	TDD	1337
9.3.4.2	Minimum requirement PUCCH 2-0 (Cell-Specific Reference Symbols)	1338
9.3.4.2.1	FDD	1338
9.3.4.2.2	TDD	1340
9.3.5	Additional requirements for enhanced receiver Type A	1342
9.3.5.1	Minimum requirement PUCCH 1-0 (Cell-Specific Reference Symbol)	1342
9.3.5.1.1	FDD	1342
9.3.5.1.2	TDD	1343
9.3.5.2	Minimum requirement PUCCH 1-1 (CSI Reference Symbol)	1345
9.3.5.2.1	FDD	1345
9.3.5.2.2	TDD	1348
9.3.6	Minimum requirement (With multiple CSI processes)	1351
9.3.6.1	FDD	1352
9.3.6.2	TDD	1356
9.3.7	Minimum requirement PUSCH 3-2	1360
9.3.7.1	FDD	1360
9.3.7.2	TDD	1361
9.3.8	Additional requirements for enhanced receiver Type B	1363
9.3.8.1	Minimum requirement PUCCH 1-1 (Cell-Specific Reference Symbols)	1363
9.3.8.1.1	FDD	1363
9.3.8.1.2	TDD	1364
9.3.8.2	Minimum requirement PUCCH 1-1 (CSI Reference Symbols)	1366
9.3.8.2.1	FDD	1366
9.3.8.2.2	TDD	1368
9.3.8.3	Minimum requirement with CSI process	1371
9.3.8.3.1	FDD	1371
9.3.8.3.2	TDD	1374
9.4	Reporting of Precoding Matrix Indicator (PMI)	1377
9.4.1	Single PMI	1378
9.4.1.1	Minimum requirement PUSCH 3-1 (Cell-Specific Reference Symbols)	1378
9.4.1.1.1	FDD	1378
9.4.1.1.2	TDD	1379
9.4.1.2	Minimum requirement PUCCH 2-1 (Cell-Specific Reference Symbols)	1380
9.4.1.2.1	FDD	1380
9.4.1.2.2	TDD	1382
9.4.1.3	Minimum requirement PUSCH 3-1 (CSI Reference Symbol)	1383
9.4.1.3.1	FDD	1383
9.4.1.3.2	TDD	1386
9.4.1.3.3	FDD (with Class A 12Tx codebook)	1389
9.4.1.3.4	TDD (with Class A 12Tx codebook)	1391
9.4.1.3.5	FDD (with Class A 24Tx codebook)	1394
9.4.1.3.6	TDD (with Class A 24Tx codebook)	1396
9.4.1.4	Minimum requirement PUCCH 1-1 (CSI Reference Symbol)	1399

9.4.1.4.1	FDD (with 4Tx enhanced codebook) .....	1399
9.4.1.4.2	TDD (with 4Tx enhanced codebook) .....	1401
9.4.1.4.3	FDD (with Class B alternative codebook for one CSI-RS resource configured).....	1404
9.4.1.4.4	TDD (with Class B alternative codebook for one CSI-RS resource configured) .....	1406
9.4.1a	Void .....	1409
9.4.1a.1	Void.....	1409
9.4.1a.1.1	Void.....	1409
9.4.1a.1.2	Void .....	1409
9.4.2	Multiple PMI .....	1409
9.4.2.1	Minimum requirement PUSCH 1-2 (Cell-Specific Reference Symbols).....	1409
9.4.2.1.1	FDD.....	1409
9.4.2.1.2	TDD.....	1410
9.4.2.2	Minimum requirement PUSCH 2-2 (Cell-Specific Reference Symbols).....	1411
9.4.2.2.1	FDD.....	1411
9.4.2.2.2	TDD.....	1412
9.4.2.3	Minimum requirement PUSCH 1-2 (CSI Reference Symbol) .....	1413
9.4.2.3.1	FDD.....	1413
9.4.2.3.2	TDD.....	1415
9.4.2.3.3	FDD (with 4Tx enhanced codebook) .....	1418
9.4.2.3.4	TDD (with 4Tx enhanced codebook) .....	1420
9.4.2.3.5	FDD (with Class A 16Tx codebook).....	1422
9.4.2.3.6	TDD (with Class A 16Tx codebook).....	1425
9.4.2.3.7	FDD (with Class A 32Tx codebook).....	1428
9.4.2.3.8	TDD (with Class A 32Tx codebook).....	1431
9.4.2.3.9	FDD (with Class A 16Tx advanced codebook).....	1434
9.4.2.3.10	TDD (with Class A 16Tx advanced codebook).....	1437
9.4.3	Void .....	1440
9.5	Reporting of Rank Indicator (RI) .....	1440
9.5.1	Minimum requirement (Cell-Specific Reference Symbols).....	1440
9.5.1.1	FDD.....	1440
9.5.1.2	TDD .....	1441
9.5.2	Minimum requirement (CSI Reference Symbols) .....	1442
9.5.2.1	FDD.....	1442
9.5.2.2	TDD .....	1444
9.5.3	Minimum requirement (CSI measurements in case two CSI subframe sets are configured) .....	1446
9.5.3.1	FDD.....	1446
9.5.3.2	TDD .....	1449
9.5.4	Minimum requirement (CSI measurements in case two CSI subframe sets are configured and CRS assistance information are configured) .....	1452
9.5.4.1	FDD.....	1452
9.5.4.2	TDD .....	1455
9.5.5	Minimum requirement (with CSI process) .....	1458
9.5.5.1	FDD.....	1459
9.5.5.2	TDD .....	1462
9.6	Additional requirements for carrier aggregation .....	1465
9.6.1	Periodic reporting on multiple cells (Cell-Specific Reference Symbols) .....	1465
9.6.1.1	FDD.....	1465
9.6.1.2	TDD .....	1471
9.6.1.3	TDD-FDD CA with FDD PCell.....	1477
9.6.1.4	TDD-FDD CA with TDD PCell.....	1482
9.7	CSI reporting (Single receiver antenna) .....	1488
9.7.1	CQI reporting definition under AWGN conditions .....	1489
9.7.1.1	FDD and half-duplex FDD.....	1489
9.7.1.2	TDD .....	1489
9.7.1.3	FDD (Category 1bis UE).....	1490
9.7.1.4	TDD (Category 1bis UE) .....	1491
9.7.2	CQI reporting under fading conditions .....	1492
9.7.2.1	FDD and half-duplex FDD.....	1492
9.7.2.2	TDD .....	1493
9.7.2.3	FDD (Category 1bis UE).....	1494
9.7.2.4	TDD (Category 1bis UE) .....	1495
9.8	CSI reporting (UE supporting coverage enhancement) .....	1496



9.8.1	CQI reporting definition under AWGN conditions .....	1496
9.8.1.1	FDD and half-duplex FDD.....	1496
9.8.1.2	TDD .....	1497
9.8.2	UE-selected subband CQI.....	1498
9.8.2.1	FDD and half-duplex FDD.....	1498
9.8.2.2	TDD .....	1502
9.8.3	CQI reporting definition for UE supporting 64QAM under AWGN.....	1505
9.8.3.1	FDD and half-duplex FDD.....	1505
9.8.3.2	TDD .....	1506
9.8.4	CQI reporting definition for UE supporting alternative table under AWGN.....	1507
9.8.4.1	FDD and half-duplex FDD.....	1507
9.8.4.2	TDD .....	1508
9.8.5	PMI reporting with PUCCH 1-1 (CSI Reference Symbol).....	1509
9.8.5.1	FDD.....	1510
9.8.5.2	TDD .....	1511
9.9	CSI reporting for 4Rx UE .....	1512
9.9.1	CQI reporting definition under AWGN conditions .....	1512
9.9.1.1	Minimum requirement PUCCH 1-0 with Rank 1 (Cell-Specific Reference Symbols) .....	1513
9.9.1.1.1	FDD.....	1513
9.9.1.1.2	TDD.....	1513
9.9.1.2	Minimum requirement PUCCH 1-1 with Rank 2 (CSI Reference Symbols).....	1514
9.9.1.2.1	FDD.....	1514
9.9.1.2.2	TDD.....	1515
9.9.1.3	Minimum requirement PUCCH 1-1 with Rank 4 (Cell-Specific Reference Symbols) .....	1516
9.9.1.3.1	FDD.....	1517
9.9.1.3.2	TDD.....	1517
9.9.1.4	Minimum requirement PUCCH 1-1 with Rank 3 (CSI Reference Symbols).....	1518
9.9.1.4.1	FDD.....	1518
9.9.1.4.2	TDD.....	1519
9.9.2	CQI reporting definition under fading conditions.....	1520
9.9.2.1	Minimum requirement PUCCH 1-0 (Cell-Specific Reference Symbol) for enhanced receiver Type A .....	1520
9.9.2.1.1	FDD.....	1521
9.9.2.1.2	TDD.....	1522
9.9.2.2	Minimum requirement PUCCH 1-1 (CSI Reference Symbol) for enhanced receiver Type A .....	1525
9.9.2.2.1	FDD.....	1525
9.9.2.2.2	TDD.....	1528
9.9.3	Reporting of Precoding Matrix Indicator (PMI) for 4Rx UE.....	1531
9.9.3.1	Minimum requirement PUSCH 3-1 (CSI Reference Symbol) .....	1532
9.9.3.1.1	TDD.....	1532
9.9.4	Reporting of Rank Indicator (RI).....	1534
9.9.4.1	Minimum requirement (Cell-Specific Reference Symbols) .....	1534
9.9.4.1.1	FDD.....	1534
9.9.4.1.2	TDD.....	1536
9.9.4.2	Minimum requirement (CSI Reference Symbols).....	1537
9.9.4.2.1	FDD.....	1537
9.9.4.2.2	TDD.....	1539
9.10	Reporting of CSI-RS Resource Indicator (CRI).....	1541
9.10.1	Minimum requirement (PUSCH 3-1) .....	1542
9.10.1.1	FDD.....	1542
9.10.1.2	TDD .....	1544
9.10.2	Minimum requirement (PUSCH 3-1, QCL Type C).....	1546
9.10.2.1	FDD.....	1546
9.10.2.2	TDD .....	1549
9.11	Reporting of Hybrid Channel state information .....	1552
9.11.1	Minimum requirement (with eMIMO-Type configured as Class B with more than one CSI-RS resource configured and eMIMO-Type2 as Class B with one CSI-RS resource configured).....	1552
9.11.1.1	FDD.....	1553
9.11.1.2	TDD .....	1555
9.12	CSI reporting (UE supporting Short TTI) .....	1557
9.12.1	CQI reporting under fading conditions (Cell-Specific Reference Symbol) .....	1557
9.12.1.1	FDD.....	1557

9.12.1.2	TDD .....	1560
9.12.2	CQI reporting under fading conditions (CSI Reference Symbol) .....	1561
9.12.2.1	FDD .....	1561
9.12.2.2	TDD .....	1564
9.13	CSI reporting for 8Rx UE .....	1566
9.13.1	CQI reporting definition under AWGN conditions .....	1566
9.13.1.1	Minimum requirement PUCCH 1-1 with Rank 4 (CSI Reference Symbols) .....	1566
9.13.1.2.1	Void .....	1566
9.13.1.2.2	TDD .....	1566
10	Performance requirement (MBMS) .....	1567
10.1	FDD (Fixed Reference Channel) .....	1567
10.1.1	Minimum requirement .....	1568
10.2	TDD (Fixed Reference Channel) .....	1569
10.2.1	Minimum requirement .....	1569
10.3	FDD (Fixed Reference Channel) with FeMBMS .....	1570
10.3.1	Minimum requirement for FeMBMS Unicast-mixed Cell under CA .....	1570
10.3.1.1	Minimum requirement with 1.25kHz subcarrier spacing .....	1570
10.3.1.2	Minimum requirement with 7.5kHz subcarrier spacing .....	1571
10.3.2	Minimum requirement for FeMBMS Unicast-mixed Cell as Non-Serving Cell .....	1572
10.3.2.1	Minimum requirement with 1.25kHz subcarrier spacing .....	1572
10.3.2.2	Minimum requirement with 7.5kHz subcarrier spacing .....	1573
10.3.3	Minimum requirement for MBMS Dedicated cell .....	1574
10.3.3.1	Minimum requirement with 1.25kHz subcarrier spacing .....	1574
10.3.3.2	Minimum requirement with 7.5kHz subcarrier spacing .....	1575
10.3.3.3	Minimum requirement with 15kHz subcarrier spacing .....	1576
10.4	FDD with 5G terrestrial broadcast .....	1577
10.4.1	Minimum requirement for PMCH decoding .....	1577
10.4.1.1	Minimum requirement with 0.37kHz subcarrier spacing .....	1577
10.4.1.2	Minimum requirement with 2.5kHz subcarrier spacing .....	1578
10.4.2	Minimum requirement for CAS detection .....	1579
10.4.2.1	Minimum requirement for PBCH detection .....	1579
11	Performance requirement (ProSe Direct Discovery) .....	1579
11.1	General .....	1580
11.1.1	Applicability of requirements .....	1580
11.1.2	Reference DRX configuration .....	1580
11.2	Demodulation of PSDCH (single link performance) .....	1580
11.2.1	FDD (in-coverage) .....	1580
11.2.2	TDD (in-coverage) .....	1581
11.2.3	FDD (out-of-coverage) .....	1582
11.3	Power imbalance performance with two links .....	1583
11.3.1	FDD .....	1583
11.3.2	TDD .....	1584
11.4	Multiple timing reference test .....	1585
11.4.1	FDD .....	1586
11.5	Maximum Sidelink processes test .....	1587
11.5.1	FDD .....	1587
11.5.2	TDD .....	1588
12	Performance requirement (ProSe Direct Communication) .....	1590
12.1	General .....	1590
12.1.1	Applicability of requirements .....	1590
12.1.1.1	Applicability of requirements for different channel bandwidths .....	1590
12.1.1.2	Test coverage for different number of component carriers .....	1590
12.1.1.3	Applicability and test rules for different CA configurations and bandwidth combination sets .....	1590
12.1.2	Reference DRX configuration .....	1591
12.2	Demodulation of PSSCH .....	1591
12.2.1	FDD .....	1591
12.3	Demodulation of PSCCH .....	1592
12.3.1	FDD .....	1593
12.4	Demodulation of PSBCH .....	1594
12.4.1	FDD .....	1594

12.5	Power imbalance performance with two links.....	1594
12.5.1	FDD .....	1594
12.6	Multiple timing reference test .....	1596
12.6.1	FDD .....	1596
12.7	Maximum Sidelink processes test .....	1599
12.7.1	FDD .....	1599
12.8	Sustained downlink data rate with active Sidelink .....	1600
13	Void.....	1602
14	Performance requirement (V2X Sidelink Communication).....	1602
14.1	General .....	1602
14.1.1	Applicability of requirements .....	1602
14.2	Demodulation of PSSCH.....	1603
14.3	Demodulation of PSCCH .....	1604
14.4	Power imbalance performance with two links.....	1604
14.5	Demodulation of PSBCH .....	1605
14.6	Demodulation of PSSCH with eNB based synchronization .....	1606
14.7	Soft buffer test .....	1606
14.8	PSCCH/PSSCH decoding capability test .....	1607
14.9	Sustained downlink data rate with active sidelink.....	1608
14.10	Soft buffer test (CA).....	1609
14.11	PSCCH/PSSCH decoding capability test (CA) .....	1610
<b>Annex A (normative):</b>	<b>Measurement channels .....</b>	<b>1613</b>
A.1	General .....	1613
A.2	UL reference measurement channels .....	1613
A.2.1	General .....	1613
A.2.1.1	Applicability and common parameters .....	1613
A.2.1.2	Determination of payload size .....	1613
A.2.1.3	Overview of UL reference measurement channels .....	1614
A.2.2	Reference measurement channels for FDD.....	1637
A.2.2.1	Full RB allocation.....	1637
A.2.2.1.1	QPSK .....	1637
A.2.2.1.2	16-QAM .....	1639
A.2.2.1.3	64-QAM .....	1641
A.2.2.1.4	256 QAM .....	1642
A.2.2.2	Partial RB allocation.....	1642
A.2.2.2.1	QPSK .....	1643
A.2.2.2.2	16-QAM .....	1646
A.2.2.2.3	64-QAM .....	1648
A.2.2.2.4	256 QAM .....	1650
A.2.2.3	Void .....	1650
A.2.3	Reference measurement channels for TDD.....	1651
A.2.3.1	Full RB allocation.....	1651
A.2.3.1.1	QPSK .....	1651
A.2.3.1.2	16-QAM .....	1653
A.2.3.1.3	64-QAM .....	1656
A.2.3.1.4	256 QAM .....	1656
A.2.3.2	Partial RB allocation.....	1656
A.2.3.2.1	QPSK .....	1657
A.2.3.2.2	16-QAM .....	1661
A.2.3.2.3	64-QAM .....	1666
A.2.3.2.4	256 QAM .....	1668
A.2.3.3	Void .....	1668
A.2.4	Reference measurement channels for UE category NB1.....	1669
A.2.5	Reference measurement channels for LAA .....	1670
A.2.5.1	Full RB allocation.....	1670
A.2.5.1.1	QPSK .....	1670
A.2.5.1.2	16QAM .....	1670
A.2.5.1.3	64QAM .....	1671

A.2.5.2	Partial RB allocation .....	1671
A.2.5.2.1	QPSK .....	1671
A.2.5.2.2	16QAM .....	1672
A.2.5.2.3	64QAM .....	1672
A.3	DL reference measurement channels .....	1673
A.3.1	General .....	1673
A.3.1.1	Overview of DL reference measurement channels .....	1673
A.3.2	Reference measurement channel for receiver characteristics .....	1699
A.3.3	Reference measurement channels for PDSCH performance requirements (FDD) .....	1729
A.3.3.1	Single-antenna transmission (Common Reference Symbols) .....	1729
A.3.3.2	Multi-antenna transmission (Common Reference Symbols) .....	1734
A.3.3.2.1	Two antenna ports .....	1734
A.3.3.2.2	Four antenna ports .....	1742
A.3.3.3	Reference Measurement Channel for UE-Specific Reference Symbols .....	1747
A.3.3.3.0	Two antenna ports (no CSI-RS) .....	1747
A.3.3.3.1	Two antenna port (CSI-RS) .....	1748
A.3.3.3.2	Four antenna ports (CSI-RS) .....	1751
A.3.3.3.2A	Eight antenna ports (CSI-RS) .....	1758
A.3.3.3.3	Twelve antenna port (CSI-RS) .....	1760
A.3.3.3.4	Sixteen antenna port (CSI-RS) .....	1761
A.3.3.3.5	Twenty-four antenna port (CSI-RS) .....	1762
A.3.3.3.6	Thirty-two antenna port (CSI-RS) .....	1763
A.3.4	Reference measurement channels for PDSCH performance requirements (TDD) .....	1765
A.3.4.1	Single-antenna transmission (Common Reference Symbols) .....	1765
A.3.4.2	Multi-antenna transmission (Common Reference Signals) .....	1773
A.3.4.2.1	Two antenna ports .....	1773
A.3.4.2.2	Four antenna ports .....	1785
A.3.4.3	Reference Measurement Channels for UE-Specific Reference Symbols .....	1792
A.3.4.3.1	Single antenna port (Cell Specific) .....	1792
A.3.4.3.2	Two antenna ports (Cell Specific) .....	1793
A.3.4.3.3	Two antenna ports (CSI-RS) .....	1795
A.3.4.3.4	Four antenna ports (CSI-RS) .....	1802
A.3.4.3.5	Eight antenna ports (CSI-RS) .....	1809
A.3.4.3.6	Twelve antenna ports (CSI-RS) .....	1813
A.3.4.3.7	Sixteen antenna ports (CSI-RS) .....	1814
A.3.4.3.8	Twenty-four antenna ports (CSI-RS) .....	1815
A.3.4.3.9	Thirty-two antenna ports (CSI-RS) .....	1816
A.3.5	Reference measurement channels for PDCCH/PCFICH performance requirements .....	1818
A.3.5.1	FDD .....	1818
A.3.5.2	TDD .....	1818
A.3.5.3	LAA .....	1819
A.3.6	Reference measurement channels for PHICH performance requirements .....	1819
A.3.7	Reference measurement channels for PBCH performance requirements .....	1819
A.3.8	Reference measurement channels for MBMS performance requirements .....	1820
A.3.8.1	FDD .....	1820
A.3.8.2	TDD .....	1825
A.3.9	Reference measurement channels for sustained downlink data rate provided by lower layers .....	1827
A.3.9.1	FDD .....	1827
A.3.9.2	TDD .....	1831
A.3.9.3	FDD (EPDCCH scheduling) .....	1845
A.3.9.4	TDD (EPDCCH scheduling) .....	1846
A.3.9.5	LAA .....	1848
A.3.10	Reference Measurement Channels for EPDCCH performance requirements .....	1850
A.3.10.1	FDD .....	1850
A.3.10.2	TDD .....	1850
A.3.11	Reference Measurement Channels for MPDCCH performance requirements .....	1850
A.3.11.1	FDD and half-duplex FDD .....	1850
A.3.11.2	TDD .....	1851
A.3.12	Reference measurement channels for NPDSCH performance requirements .....	1852
A.3.12.1	In-band .....	1852
A.3.12.1.2	Two-antenna transmission .....	1852

A.3.12.2	Standalone/Guard-band .....	1854
A.3.12.2.1	Single-antenna transmission .....	1854
A.3.13	Reference measurement channels for NPDCCH performance requirements .....	1857
A.3.13.1	Half-duplex FDD .....	1857
A.3.13.2	TDD .....	1858
A.3.14	Reference measurement channels for NPBCH performance requirements for Cat NB1 UEs.....	1858
A.3.15	Reference Measurement Channels for LAA SCell with frame structure Type-3 .....	1859
A.3.15.1	Multi-antenna transmission (Common Reference Symbols) .....	1859
A.3.15.1.1	Four antenna ports .....	1859
A.3.15.2	Reference Measurement Channel for UE-Specific Reference Symbols .....	1859
A.3.15.2.1	Two antenna ports (CSI-RS) .....	1859
A.3.16	Reference measurement channels for Slot-PDSCH and Subslot-PDSCH performance requirements .....	1861
A.3.16.1	FDD .....	1861
A.3.16.2	TDD .....	1865
A.3.17	Reference measurement channels for SPDCCH performance requirements .....	1866
A.3.17.1	FDD .....	1866
A.3.17.2	TDD .....	1867
A.4	CSI reference measurement channels.....	1867
A.5	OFDMA Channel Noise Generator (OCNG) .....	1880
A.5.1	OCNG Patterns for FDD .....	1880
A.5.1.1	OCNG FDD pattern 1: One sided dynamic OCNG FDD pattern .....	1880
A.5.1.2	OCNG FDD pattern 2: Two sided dynamic OCNG FDD pattern .....	1881
A.5.1.3	OCNG FDD pattern 3: 49 RB OCNG allocation with MBSFN in 10 MHz .....	1881
A.5.1.3A	OCNG FDD pattern 3A: 49 RB OCNG allocation with MBSFN enhancement in 10 MHz .....	1882
A.5.1.4	OCNG FDD pattern 4: One sided dynamic OCNG FDD pattern for MBMS transmission .....	1882
A.5.1.4A	OCNG FDD pattern 4A: One sided dynamic OCNG FDD pattern for enhanced MBMS transmission.....	1883
A.5.1.5	OCNG FDD pattern 5: One sided dynamic 16QAM modulated OCNG FDD pattern .....	1884
A.5.1.6	OCNG FDD pattern 6: dynamic OCNG FDD pattern when user data is in 2 non-contiguous blocks....	1885
A.5.1.8	OCNG FDD pattern 8: Dynamic OCNG FDD pattern for TM10 transmission.....	1886
A.5.2	OCNG Patterns for TDD .....	1887
A.5.2.1	OCNG TDD pattern 1: One sided dynamic OCNG TDD pattern.....	1887
A.5.2.2	OCNG TDD pattern 2: Two sided dynamic OCNG TDD pattern .....	1888
A.5.2.3	OCNG TDD pattern 3: 49 RB OCNG allocation with MBSFN in 10 MHz .....	1889
A.5.2.4	OCNG TDD pattern 4: One sided dynamic OCNG TDD pattern for MBMS transmission .....	1889
A.5.2.5	OCNG TDD pattern 5: One sided dynamic 16QAM modulated OCNG TDD pattern.....	1890
A.5.2.6	OCNG TDD pattern 6: dynamic OCNG TDD pattern when user data is in 2 non-contiguous blocks ...	1891
A.5.2.8	OCNG TDD pattern 8: Dynamic OCNG TDD pattern for TM10 transmission .....	1892
A.5.3	OCNG Patterns for Narrowband IoT .....	1893
A.5.3.1	Narrowband IoT OCNG pattern 1 .....	1893
A.5.4	OCNG Patterns for frame structure type 3 .....	1894
A.5.4.1	OCNG FS3 pattern 1: One sided dynamic OCNG frame structure type 3 pattern.....	1894
A.5.4.2	OCNG FS3 pattern 2: Two sided dynamic OCNG frame structure 3 pattern .....	1895
A.6	Sidelink reference measurement channels.....	1896
A.6.1	General .....	1896
A.6.1.1	Overview of ProSe reference measurement channels .....	1896
A.6.2	Reference measurement channel for receiver characteristics .....	1897
A.6.3	Reference measurement channels for PSDCH performance requirements .....	1899
A.6.4	Reference measurement channels for PSSCH performance requirements .....	1900
A.6.5	Reference measurement channels for PSSCH performance requirements .....	1900
A.6.6	Reference measurement channels for PSBCH performance requirements .....	1901
A.7	Sidelink reference resource pool configurations .....	1902
A.7.1	Reference resource pool configurations for ProSe Direct Discovery demodulation tests .....	1902
A.7.1.1	FDD .....	1902
A.7.1.2	TDD .....	1905
A.7.2	Reference resource pool configurations for ProSe Direct Communication demodulation tests.....	1907
A.7.2.1	FDD .....	1907
A.8	V2X reference measurement channels .....	1912
A.8.1	General .....	1912
A.8.1.1	Overview of V2X reference measurement channels.....	1913

A.8.2	Reference measurement channel for receiver characteristics .....	1913
A.8.3	Reference measurement channel for transmitter characteristics.....	1915
A.8.4	Reference measurement for PSSCH performance requirements.....	1918
A.8.5	Reference measurement for PSSCH performance requirements .....	1919
A.8.6	Reference measurement for PSBCH performance requirements.....	1919
A.9	V2X reference resource pool configurations.....	1920
<b>Annex B (normative): Propagation conditions.....</b>		<b>1923</b>
B.1	Static propagation condition.....	1923
B.1.1	UE Receiver with 2Rx.....	1923
B.1.2	UE Receiver with 4Rx.....	1923
B.1.3	UE Receiver with 8Rx.....	1924
B.2	Multi-path fading propagation conditions .....	1925
B.2.1	Delay profiles .....	1925
B.2.2	Combinations of channel model parameters .....	1926
B.2.3	MIMO Channel Correlation Matrices .....	1927
B.2.3.1	Definition of MIMO Correlation Matrices .....	1927
B.2.3.2	MIMO Correlation Matrices at High, Medium and Low Level.....	1933
B.2.3A	MIMO Channel Correlation Matrices using cross polarized antennas .....	1936
B.2.3A.1	Definition of MIMO Correlation Matrices using cross polarized antennas .....	1937
B.2.3A.2	Spatial Correlation Matrices using cross polarized antennas at eNB and UE sides.....	1937
B.2.3A.2.1	Spatial Correlation Matrices at eNB side .....	1937
B.2.3A.2.2	Spatial Correlation Matrices at UE side .....	1938
B.2.3A.4	Beam steering approach.....	1941
B.2.3B	MIMO Channel Correlation Matrices using two-dimension cross polarized antennas at eNB and cross polarized antennas at UE .....	1941
B.2.3B.1	Definition of MIMO Correlation Matrices using two-dimension cross polarized antennas at eNB and cross polarized antennas at UE .....	1942
B.2.3B.2	Spatial Correlation Matrices using two-dimension cross polarized antennas at eNB and cross polarized antennas at UE .....	1943
B.2.3B.2.1	Spatial Correlation Matrices at eNB side .....	1943
B.2.3B.2.2	Spatial Correlation Matrices at UE side .....	1943
B.2.3B.3	MIMO Correlation Matrices using two-dimension cross polarized antennas at eNB and cross polarized antennas at UE .....	1943
B.2.3B.4	Beam steering approach.....	1946
B.2.3B.4A	Beam steering approach with dual cluster beams .....	1947
B.2.4	Propagation conditions for CQI tests.....	1948
B.2.4.1	Propagation conditions for CQI tests with multiple CSI processes.....	1948
B.2.5	Void .....	1948
B.2.6	MBSFN Propagation Channel Profile .....	1948
B.2.6.1	Subcarrier spacing 15kHz or 7.5kHz .....	1948
B.2.6.2	Subcarrier spacing 1.25kHz .....	1949
B.2.6.3	Subcarrier spacing 0.37kHz .....	1950
B.2.6.4	Subcarrier spacing 2.5kHz .....	1950
B.3	High speed train scenario .....	1951
B.3A	HST-SFN scenario .....	1952
B.3B	HST-SFN scenario for 500 km/h speed.....	1956
B.3C	HST scenario for 500 km/h speed .....	1956
B.4	Beamforming Model .....	1956
B.4.1	Single-layer random beamforming (Antenna port 5, 7, or 8) .....	1956
B.4.1A	Single-layer random beamforming (Antenna port 7, 8, 11 or 13 with enhanced DMRS table configured) .....	1957
B.4.2	Dual-layer random beamforming (antenna ports 7 and 8).....	1957
B.4.3	Generic beamforming model (antenna ports 7-14).....	1958
B.4.4	Random beamforming for EPDCCH distributed transmission (Antenna port 107 and 109).....	1958
B.4.5	Random beamforming for EPDCCH localized transmission (Antenna port 107, 108, 109 or 110).....	1959
B.4.6	Beamforming model for CRI test .....	1959

B.5	Interference models for enhanced performance requirements Type-A .....	1960
B.5.1	Dominant interferer proportion .....	1961
B.5.2	Transmission mode 3 interference model.....	1961
B.5.3	Transmission mode 4 interference model.....	1961
B.5.4	Transmission mode 9 interference model.....	1962
B.6	Interference models for enhanced performance requirements Type-B .....	1962
B.6.1	Transmission mode 2 interference model.....	1962
B.6.2	Transmission mode 3 interference model.....	1962
B.6.3	Transmission mode 4 interference model.....	1963
B.6.4	Transmission mode 9 interference model.....	1963
B.6.5	CRS interference model .....	1964
B.6.6	Random interference model .....	1964
B.7	Interference models for enhanced downlink control channel performance requirements Type A and B .....	1965
B.7.1	PDCCH, PCFICH and PHICH interference model .....	1965
B.8	Burst transmission models for Frame structure type 3 .....	1966
B.8.1	Burst transmission model for one LAA SCell .....	1966
B.8.2	Burst transmission model for multiple LAA SCell(s) .....	1966
<b>Annex C (normative): Downlink Physical Channels.....</b>		<b>1968</b>
C.1	General .....	1968
C.2	Set-up .....	1968
C.3	Connection .....	1968
C.3.1	Measurement of Receiver Characteristics .....	1968
C.3.2	Measurement of Performance requirements .....	1969
C.3.3	Aggressor cell power allocation for Measurement of Performance Requirements when ABS is Configured.....	1970
C.3.4	Power Allocation for Measurement of Performance Requirements when Quasi Co-location Type B: same Cell ID .....	1971
C.3.5	Simplified CA testing method .....	1971
C.3.6	Measurement of Receiver Characteristics for Narrowband IoT .....	1972
<b>Annex D (normative): Characteristics of the interfering signal .....</b>		<b>1973</b>
D.1	General .....	1973
D.2	Interference signals.....	1973
<b>Annex E (normative): Environmental conditions .....</b>		<b>1974</b>
E.1	General .....	1974
E.2	Environmental .....	1974
E.2.1	Temperature .....	1974
E.2.2	Voltage .....	1974
E.2.3	Vibration.....	1975
<b>Annex F (normative): Transmit modulation .....</b>		<b>1976</b>
F.1	Measurement Point.....	1976
F.2	Basic Error Vector Magnitude measurement .....	1976
F.3	Basic in-band emissions measurement.....	1977
F.4	Modified signal under test.....	1977
F.5	Window length .....	1979
F.5.1	Timing offset .....	1979
F.5.2	Window length .....	1979
F.5.3	Window length for normal CP .....	1979
F.5.4	Window length for Extended CP.....	1980

F.5.5	Window length for PRACH .....	1980
F.5.F	Window length for category NB1 .....	1981
F.6	Averaged EVM .....	1981
F.6.F	Averaged EVM for category NB1 .....	1982
F.7	Spectrum Flatness .....	1982
<b>Annex G (informative): Reference sensitivity level in lower SNR.....</b>		<b>1983</b>
G.1	General .....	1983
G.2	Typical receiver sensitivity performance (QPSK) .....	1983
G.3	Reference measurement channel for REFSense in lower SNR .....	1989
<b>Annex H (normative): Modified MPR behavior.....</b>		<b>1992</b>
H.1	Indication of modified MPR behavior.....	1992
<b>Annex I (normative): Supported Post Antenna Gain .....</b>		<b>1993</b>
I.1	Declared Supported Post Antenna Gain for UE .....	1993
<b>Annex J (informative): Change history .....</b>		<b>1994</b>
History .....		2040



---

## Foreword

This Technical Specification has been produced by the 3rd Generation Partnership Project (3GPP).

The contents of the present document are subject to continuing work within the TSG and may change following formal TSG approval. Should the TSG modify the contents of the present document, it will be re-released by the TSG with an identifying change of release date and an increase in version number as follows:

Version x.y.z

where:

- x the first digit:
  - 1 presented to TSG for information;
  - 2 presented to TSG for approval;
  - 3 or greater indicates TSG approved document under change control.
- y the second digit is incremented for all changes of substance, i.e. technical enhancements, corrections, updates, etc.
- z the third digit is incremented when editorial only changes have been incorporated in the document.

In the present document, modal verbs have the following meanings:

- shall** indicates a mandatory requirement to do something
- shall not** indicates an interdiction (prohibition) to do something

The constructions "shall" and "shall not" are confined to the context of normative provisions, and do not appear in Technical Reports.

The constructions "must" and "must not" are not used as substitutes for "shall" and "shall not". Their use is avoided insofar as possible, and they are not used in a normative context except in a direct citation from an external, referenced, non-3GPP document, or so as to maintain continuity of style when extending or modifying the provisions of such a referenced document.

- should** indicates a recommendation to do something
- should not** indicates a recommendation not to do something
- may** indicates permission to do something
- need not** indicates permission not to do something

The construction "may not" is ambiguous and is not used in normative elements. The unambiguous constructions "might not" or "shall not" are used instead, depending upon the meaning intended.

- can** indicates that something is possible
- cannot** indicates that something is impossible

The constructions "can" and "cannot" are not substitutes for "may" and "need not".

- will** indicates that something is certain or expected to happen as a result of action taken by an agency the behaviour of which is outside the scope of the present document
- will not** indicates that something is certain or expected not to happen as a result of action taken by an agency the behaviour of which is outside the scope of the present document
- might** indicates a likelihood that something will happen as a result of action taken by some agency the behaviour of which is outside the scope of the present document

**might not** indicates a likelihood that something will not happen as a result of action taken by some agency the behaviour of which is outside the scope of the present document

In addition:

**is** (or any other verb in the indicative mood) indicates a statement of fact

**is not** (or any other negative verb in the indicative mood) indicates a statement of fact

The constructions "is" and "is not" do not indicate requirements.

---

# 1 Scope

The present document establishes the minimum RF characteristics and minimum performance requirements for E-UTRA User Equipment (UE).

---

## 2 References

The following documents contain provisions which, through reference in this text, constitute provisions of the present document.

- References are either specific (identified by date of publication, edition number, version number, etc.) or non-specific.
- For a specific reference, subsequent revisions do not apply.
- For a non-specific reference, the latest version applies. In the case of a reference to a 3GPP document (including a GSM document), a non-specific reference implicitly refers to the latest version of that document *in the same Release as the present document*.

- [1] 3GPP TR 21.905: "Vocabulary for 3GPP Specifications".
- [2] ITU-R Recommendation SM.329-10, "Unwanted emissions in the spurious domain"
- [3] ITU-R Recommendation M.1545: "Measurement uncertainty as it applies to test limits for the terrestrial component of International Mobile Telecommunications-2000".
- [4] 3GPP TS 36.211: "Physical Channels and Modulation".
- [5] 3GPP TS 36.212: "Multiplexing and channel coding".
- [6] 3GPP TS 36.213: "Physical layer procedures".
- [7] 3GPP TS 36.331: " Requirements for support of radio resource management ".
- [8] 3GPP TS 36.307: " Requirements on User Equipments (UEs) supporting a release-independent frequency band".
- [9] 3GPP TS 36.423: "X2 application protocol (X2AP) ".
- [10] 3GPP TS 23.303: "Technical Specification Group Services and System Aspects; Proximity-based services (ProSe); Stage 2".
- [11] 3GPP TS36.300: "Evolved Universal Terrestrial Radio Access (E-UTRA) and Evolved Universal Terrestrial Radio Access Network (E-UTRAN); Overall description; Stage 2".
- [12] 3GPP TS36.104: "Base Station (BS) radio transmission and reception".
- [13] ETSI TS 102 792: "Intelligent Transport Systems (ITS); Mitigation techniques to avoid interference between European CEN Dedicated Short Range Communication (CEN DSRC) equipment and Intelligent Transport Systems (ITS) operating in the 5 GHz frequency range".

---

## 3 Definitions, symbols and abbreviations

### 3.1 Definitions

For the purposes of the present document, the terms and definitions given in TR 21.905 [1] and the following apply in the case of a single component carrier. A term defined in the present document takes precedence over the definition of the same term, if any, in TR 21.905 [1].

**Aggregated Channel Bandwidth:** The RF bandwidth in which a UE transmits and receives multiple contiguously aggregated carriers.

**Aggregated Transmission Bandwidth Configuration:** The number of resource block allocated within the aggregated channel bandwidth.

**Carrier aggregation:** Aggregation of two or more component carriers in order to support wider transmission bandwidths.

**Carrier aggregation band:** A set of one or more operating bands across which multiple carriers are aggregated with a specific set of technical requirements.

**Carrier aggregation bandwidth class:** A class defined by the aggregated transmission bandwidth configuration and maximum number of component carriers supported by a UE.

**Carrier aggregation configuration:** A combination of CA operating band(s) and CA bandwidth class(es) supported by a UE.

**Channel edge:** The lowest and highest frequency of the carrier, separated by the channel bandwidth.

**Channel bandwidth:** The RF bandwidth supporting a single E-UTRA RF carrier with the transmission bandwidth configured in the uplink or downlink of a cell. The channel bandwidth is measured in MHz and is used as a reference for transmitter and receiver RF requirements.

**Composite spectrum emission mask:** Emission mask requirement for intraband non-contiguous carrier aggregation which is a combination of individual sub-block spectrum emissions masks.

**Composite spurious emission requirement:** Spurious emission requirement for intraband non-contiguous carrier aggregation which is a combination of individual sub-block spurious emission requirements.

**Contiguous carriers:** A set of two or more carriers configured in a spectrum block where there are no RF requirements based on co-existence for un-coordinated operation within the spectrum block.

**Contiguous resource allocation:** A resource allocation of consecutive resource blocks within one carrier or across contiguously aggregated carriers. The gap between contiguously aggregated carriers due to the nominal channel spacing is allowed.

**Contiguous spectrum:** Spectrum consisting of a contiguous block of spectrum with no sub-block gaps.

**Enhanced downlink control channel performance requirements type A:** This defines performance requirements for downlink control channel assuming as baseline receiver reference symbol based linear minimum mean square error interference rejection combining plus CRS interference cancellation.

**Enhanced downlink control channel performance requirements type B:** This defines performance requirements for downlink control channel assuming as baseline receiver reference symbol based enhanced linear minimum mean square error interference rejection combining plus CRS interference cancellation.

**Enhanced performance requirements type A:** This defines performance requirements assuming as baseline receiver reference symbol based linear minimum mean square error interference rejection combining.

**Enhanced performance requirements type B:** This defines performance requirements assuming as baseline receiver using network assisted interference cancellation and suppression.

**Enhanced performance requirements type C:** This defines performance requirements assuming as baseline receiver inter-stream interference cancellation.

**Inter-band carrier aggregation:** Carrier aggregation of component carriers in different operating bands.

NOTE: Carriers aggregated in each band can be contiguous or non-contiguous.

**Intra-band contiguous carrier aggregation:** Contiguous carriers aggregated in the same operating band.

**Intra-band non-contiguous carrier aggregation:** Non-contiguous carriers aggregated in the same operating band.

**Lower sub-block edge:** The frequency at the lower edge of one sub-block. It is used as a frequency reference point for both transmitter and receiver requirements.

**Category NB1/NB2 stand-alone operation:** category NB1/NB2 is operating standalone when it utilizes its own spectrum, for example the spectrum used by GERAN systems as a replacement of one or more GSM carriers, as well as scattered spectrum for potential IoT deployment.

**Category NB1/NB2 guard band operation:** category NB1/NB2 is operating in guard band when it utilizes the unused resource block(s) within a E-UTRA carrier's guard-band.

**Category NB1/NB2 in-band operation:** category NB1/NB2 is operating in-band when it utilizes the resource block(s) within a normal E-UTRA carrier or within a normal NR carrier plus 15 kHz at each edge (and not within NR minimum guard band).

**Non-contiguous spectrum:** Spectrum consisting of two or more sub-blocks separated by sub-block gap(s).

**ProSe-enabled UE:** A UE that supports ProSe requirements and associated procedures.

NOTE: As defined in TS 23.303 [10].

**ProSe Direct Communication:** A communication between two or more UEs in proximity that are ProSe-enabled.

NOTE: As defined in TS 23.303 [10].

**ProSe Direct Discovery:** A procedure employed by a ProSe-enabled UE to discover other ProSe-enabled UEs in its vicinity.

NOTE: As defined in TS 23.303 [10].

**sTTI :** A transmission time interval (TTI) of either one slot or one subslot as defined in TS 36.211 [4] on either uplink or downlink.

**Sub-block:** This is one contiguous allocated block of spectrum for transmission and reception by the same UE. There may be multiple instances of sub-blocks within an RF bandwidth.

**Sub-block bandwidth:** The bandwidth of one sub-block.

**Sub-block gap:** A frequency gap between two consecutive sub-blocks within an RF bandwidth, where the RF requirements in the gap are based on co-existence for un-coordinated operation.

**Synchronized operation:** Operation of TDD in two different systems, where no simultaneous uplink and downlink occur.

**Unsynchronized operation:** Operation of TDD in two different systems, where the conditions for synchronized operation are not met.

**Upper sub-block edge:** The frequency at the upper edge of one sub-block. It is used as a frequency reference point for both transmitter and receiver requirements.

**V2X Communication:** V2X (Vehicle to Everything) service is operating in ITS spectrum and/or LTE licensed operating bands.

## 3.2 Symbols

For the purposes of the present document, the following symbols apply:

$BW_{\text{Channel}}$	Channel bandwidth
$BW_{\text{Channel,block}}$	Sub-block bandwidth, expressed in MHz. $BW_{\text{Channel,block}} = F_{\text{edge,block,high}} - F_{\text{edge,block,low}}$ .
$BW_{\text{Channel,CA}}$	Aggregated channel bandwidth, expressed in MHz.
$BW_{\text{GB}}$	Virtual guard band to facilitate transmitter (receiver) filtering above / below edge CCs.
$E_{RS}$	Transmitted energy per RE for reference symbols during the useful part of the symbol, i.e. excluding the cyclic prefix, (average power normalized to the subcarrier spacing) at the eNode B transmit antenna connector

$\hat{E}_s$	The averaged received energy per RE of the wanted signal during the useful part of the symbol, i.e. excluding the cyclic prefix, at the UE antenna connector; average power is computed within a set of REs used for the transmission of physical channels (including user specific RSs when present), divided by the number of REs within the set, and normalized to the subcarrier spacing
F	Frequency
$F_{\text{agg\_alloc\_low}}$	Aggregated Transmission Bandwidth Configuration. The lowest frequency of the simultaneously transmitted resource blocks.
$F_{\text{agg\_alloc\_high}}$	Aggregated Transmission Bandwidth Configuration. The highest frequency of the simultaneously transmitted resource blocks.
$F_{\text{Interferer}}(\text{offset})$	Frequency offset of the interferer (between the center frequency of the interferer and the carrier frequency of the carrier measured)
$F_{\text{Interferer}}$	Frequency of the interferer
$F_{\text{offset}}$	Frequency offset of the interferer (between the center frequency of the interferer and the closest edge of the carrier measured)
$F_C$	Frequency of the carrier centre frequency
$F_{C\_agg}$	Aggregated Transmission Bandwidth Configuration. Center frequency of the aggregated carriers.
$F_{C\_block\_high}$	Center frequency of the highest transmitted/received carrier in a sub-block.
$F_{C\_block\_low}$	Center frequency of the lowest transmitted/received carrier in a sub-block.
$F_{C\_low}$	The centre frequency of the <i>lowest carrier</i> , expressed in MHz.
$F_{C\_high}$	The centre frequency of the <i>highest carrier</i> , expressed in MHz.
$F_{DL\_low}$	The lowest frequency of the downlink operating band
$F_{DL\_high}$	The highest frequency of the downlink operating band
$F_{UL\_low}$	The lowest frequency of the uplink operating band
$F_{UL\_high}$	The highest frequency of the uplink operating band
$F_{\text{edge.block,low}}$	The lower sub-block edge, where $F_{\text{edge.block,low}} = F_{C\_block,low} - F_{\text{offset}}$ .
$F_{\text{edge.block,high}}$	The upper sub-block edge, where $F_{\text{edge.block,high}} = F_{C\_block,high} + F_{\text{offset}}$ .
$F_{\text{edge\_low}}$	The <i>lower edge</i> of aggregated channel bandwidth, expressed in MHz.
$F_{\text{edge\_high}}$	The <i>higher edge</i> of aggregated channel bandwidth, expressed in MHz.
$F_{\text{offset}}$	Frequency offset from $F_{C\_high}$ to the <i>higher edge</i> or $F_{C\_low}$ to the <i>lower edge</i> .
$F_{\text{offset.block,low}}$	Separation between lower edge of a sub-block and the center of the lowest component carrier within the sub-block
$F_{\text{offset.block,high}}$	Separation between higher edge of a sub-block and the center of the highest component carrier within the sub-block
$F_{\text{offset\_NS\_23}}$	Frequency offset in MHz needed if NS_23 is used
$F_{\text{OOB}}$	The boundary between the E-UTRA out of band emission and spurious emission domains.
$I_o$	The power spectral density of the total input signal (power averaged over the useful part of the symbols within the transmission bandwidth configuration, divided by the total number of RE for this configuration and normalised to the subcarrier spacing) at the UE antenna connector, including the own-cell downlink signal
$I_{or}$	The total transmitted power spectral density of the own-cell downlink signal (power averaged over the useful part of the symbols within the transmission bandwidth configuration, divided by the total number of RE for this configuration and normalised to the subcarrier spacing) at the eNode B transmit antenna connector
$\hat{I}_{or}$	The total received power spectral density of the own-cell downlink signal (power averaged over the useful part of the symbols within the transmission bandwidth configuration, divided by the total number of RE for this configuration and normalised to the subcarrier spacing) at the UE antenna connector
$I_{ot}$	The received power spectral density of the total noise and interference for a certain RE (average power obtained within the RE and normalized to the subcarrier spacing) as measured at the UE antenna connector
L <sub>CRB</sub>	Transmission bandwidth which represents the length of a contiguous resource block allocation expressed in units of resources blocks
L <sub>Ctone</sub>	Transmission bandwidth which represents the length of a contiguous sub-carrier allocation expressed in units of tones
$N_{cp}$	Cyclic prefix length
$N_{DL}$	Downlink EARFCN

$N_{oc}$	The power spectral density of a white noise source (average power per RE normalised to the subcarrier spacing), simulating interference from cells that are not defined in a test procedure, as measured at the UE antenna connector
$N_{oc1}$	The power spectral density of a white noise source (average power per RE normalized to the subcarrier spacing), simulating interference in non-CRS symbols in ABS subframe from cells that are not defined in a test procedure, as measured at the UE antenna connector.
$N_{oc2}$	The power spectral density of a white noise source (average power per RE normalized to the subcarrier spacing), simulating interference in CRS symbols in ABS subframe from all cells that are not defined in a test procedure, as measured at the UE antenna connector.
$N_{oc3}$	The power spectral density of a white noise source (average power per RE normalised to the subcarrier spacing), simulating interference in non-ABS subframe from cells that are not defined in a test procedure, as measured at the UE antenna connector
$N_{oc}'$	The power spectral density (average power per RE normalised to the subcarrier spacing) of the summation of the received power spectral densities of the strongest interfering cells explicitly defined in a test procedure plus $N_{oc}$ , as measured at the UE antenna connector. The respective power spectral density of each interfering cell relative to $N_{oc}'$ is defined by its associated DIP value, or the respective power spectral density of each interfering cell relative to $N_{oc}$ is defined by its associated $E_s/N_{oc}$ value.
$N_{offs-DL}$	Offset used for calculating downlink EARFCN
$N_{offs-UL}$	Offset used for calculating uplink EARFCN
$N_{otx}$	The power spectral density of a white noise source (average power per RE normalised to the subcarrier spacing) simulating eNode B transmitter impairments as measured at the eNode B transmit antenna connector
$N_{RB}$	Transmission bandwidth configuration, expressed in units of resource blocks
$N_{RB\_agg}$	The number of the aggregated RBs within the fully allocated Aggregated Channel Bandwidth.
$N_{RB\_alloc}$	Total number of simultaneously transmitted resource blocks in Channel bandwidth or Aggregated Channel Bandwidth.
$N_{RB,c}$	The transmission bandwidth configuration of component carrier $c$ , expressed in units of resource blocks
$N_{RB\_largest\ BW}$	The largest transmission bandwidth configuration of the component carriers in the bandwidth combination, expressed in units of resource blocks
$N_{RX}$	Number of receiver antennas
$N_{tone}$	Transmission bandwidth configuration for category NB1 and NB2, expressed in units of tones.
$N_{tone\ 3.75kHz}$	Transmission bandwidth configuration for category NB1 and NB2 with 3.75 kHz sub-carrier spacing, expressed in units of tones.
$N_{tone\ 15kHz}$	Transmission bandwidth configuration for category NB1 and NB2 with 15 kHz sub-carrier spacing, expressed in units of tones.
$N_{UL}$	Uplink EARFCN.
$R_{av}$	Minimum average throughput per RB.
$P_{CMAX}$	The configured maximum UE output power.
$P_{CMAX,c}$	The configured maximum UE output power for serving cell $c$ .
$P_{EMAX}$	Maximum allowed UE output power signalled by higher layers. Same as IE $P-Max$ , defined in [7].
$P_{EMAX,c}$	Maximum allowed UE output power signalled by higher layers for serving cell $c$ . Same as IE $P-Max$ , defined in [7].
$P_{Interferer}$	Modulated mean power of the interferer
$P_{PowerClass}$	$P_{PowerClass}$ is the nominal UE power (i.e., no tolerance).
$P_{PowerClass\_Default}$	$P_{PowerClass\_Default}$ is the default nominal UE power (i.e., no tolerance) for the band.
$P_{UMAX}$	The measured configured maximum UE output power.
$P_{uW}$	Power of an unwanted DL signal
$P_w$	Power of a wanted DL signal
$RB_{start}$	Indicates the lowest RB index of transmitted resource blocks.
$RB_{end}$	Indicates the highest RB index of transmitted resource blocks.
$T_{no\_hopping}$	Transmission period within a TTI duration when consecutive symbols are transmitted without applying any frequency hopping
$\Delta f_{OOB}$	$\Delta$ Frequency of Out Of Band emission.
$\Delta P_{PowerClass}$	Adjustment to maximum output power for a given power class.
$\Delta R_{IB,c}$	Allowed reference sensitivity relaxation due to support for inter-band CA operation, for serving cell $c$ .

$\Delta R_{IB,4R}$	Reference sensitivity adjustment due to support for 4 antenna ports.
$\Delta R_{IB,8R}$	Reference sensitivity adjustment due to support for 8 antenna ports.
$\Delta T_{IB,c}$	Allowed maximum configured output power relaxation due to support for inter-band CA operation, for serving cell $c$ .
$\Delta T_C$	Allowed operating band edge transmission power relaxation.
$\Delta T_{C,c}$	Allowed operating band edge transmission power relaxation for serving cell $c$ .
$\Delta T_{ProSe}$	Allowed operating band transmission power relaxation due to support of E-UTRA ProSe on an operating band.
$\rho_A$	According to Clause 5.2 in TS 36.213 [6]
$\rho_B$	According to Clause 5.2 in TS 36.213 [6]
$\sigma$	Test specific auxiliary variable used for the purpose of downlink power allocation, defined in Annex C.3.2.
$W_{gap}$	Sub-block gap size
$W_{gap,L}$	Sub-block gap size between lowest two CCs in frequency domain on CA_X-X-X
$W_{gap,H}$	Sub-block gap size between highest two CCs in frequency domain on CA_X-X-X

### 3.3 Abbreviations

For the purposes of the present document, the abbreviations given in TR 21.905 [1] and the following apply. An abbreviation defined in the present document takes precedence over the definition of the same abbreviation, if any, in TR 21.905 [1].

ABS	Almost Blank Subframe
ACLR	Adjacent Channel Leakage Ratio
ACS	Adjacent Channel Selectivity
A-MPR	Additional Maximum Power Reduction
AWGN	Additive White Gaussian Noise
BS	Base Station
CA	Carrier Aggregation
CA_X	Intra-band contiguous CA of component carriers in one sub-block within Band X where X is the applicable E-UTRA operating band
CA_X-X	Intra-band non-contiguous CA of component carriers in two sub-blocks within Band X where X is the applicable E-UTRA operating band
CA_X-X-X	Intra-band non-contiguous CA of component carriers in three sub-blocks within Band X where X is the applicable E-UTRA operating band
CA_X-X-X-X	Intra-band non-contiguous CA of component carriers in four sub-blocks within Band X where X is the applicable E-UTRA operating band
CA_X-Y	Inter-band CA of component carrier(s) in one sub-block within Band X and component carrier(s) in one sub-block within Band Y where X and Y are the applicable E-UTRA operating band
CA_X-X-Y	CA of component carriers in two sub-blocks within Band X and component carrier(s) in one sub-block within Band Y where X and Y are the applicable E-UTRA operating bands
CC	Component Carriers
CG	Carrier Group
CPE	Customer Premise Equipment
CPE_X	Customer Premise Equipment for E-UTRA operating band X
CW	Continuous Wave
DC	Dual Connectivity
DC_X-Y	Inter-band DC of component carrier(s) in one sub-block within Band X and component carrier(s) in one sub-block within Band Y where X and Y are the applicable E-UTRA operating band
DL	Downlink
DIP	Dominant Interferer Proportion
EARFCN	E-UTRA Absolute Radio Frequency Channel Number
EIRP	Effective Isotropic Radiated Power
EPRE	Energy Per Resource Element
E-UTRA	Evolved UMTS Terrestrial Radio Access
EUTRAN	Evolved UMTS Terrestrial Radio Access Network
EVM	Error Vector Magnitude
FDD	Frequency Division Duplex
FRC	Fixed Reference Channel



GNSS	Global Navigation Satellite Systems
HD	Half-Duplex for Sidelink Operation
HD-FDD	Half- Duplex FDD
ITS	Intelligent Transportation Systems
MCS	Modulation and Coding Scheme
MCG	Master Cell Group
MOP	Maximum Output Power
MPR	Maximum Power Reduction
MSD	Maximum Sensitivity Degradation
OCNG	OFDMA Channel Noise Generator
OFDMA	Orthogonal Frequency Division Multiple Access
OOB	Out-of-band
PA	Power Amplifier
PCC	Primary Component Carrier
P-MPR	Power Management Maximum Power Reduction
ProSe	Proximity-based Services
PSBCH	Physical Sidelink Broadcast CHannel
PSCCH	Physical Sidelink Control CHannel
PSDCH	Physical Sidelink Discovery CHannel
PSS	Primary Synchronization Signal
PSS_RA	PSS-to-RS EPRE ratio for the channel PSS
SSSS	Secondary Sidelink Synchronization Signal
PSSSCH	Physical Sidelink Shared CHannel
PSSS	Primary Sidelink Synchronization Signal
RE	Resource Element
REFSENS	Reference Sensitivity power level
r.m.s	Root Mean Square
SCC	Secondary Component Carrier
SCG	Secondary Cell Group
SINR	Signal-to-Interference-and-Noise Ratio
SNR	Signal-to-Noise Ratio
SSS	Secondary Synchronization Signal
SSS_RA	SSS-to-RS EPRE ratio for the channel SSSSSSS Secondary Sidelink Synchronization Signal
TDD	Time Division Duplex
UE	User Equipment
UL	Uplink
UL-MIMO	Up Link Multiple Antenna transmission
UMTS	Universal Mobile Telecommunications System
UTRA	UMTS Terrestrial Radio Access
UTRAN	UMTS Terrestrial Radio Access Network
V2X	Vehicle to Everything
xCH_RA	xCH-to-RS EPRE ratio for the channel xCH in all transmitted OFDM symbols not containing cell-specific RS
xCH_RB	xCH-to-RS EPRE ratio for the channel xCH in all transmitted OFDM symbols containing cell-specific RS

## 4 General

### 4.1 Relationship between minimum requirements and test requirements

The Minimum Requirements given in this specification make no allowance for measurement uncertainty. The test specification TS 36.521-1 Annex F defines Test Tolerances. These Test Tolerances are individually calculated for each test. The Test Tolerances are used to relax the Minimum Requirements in this specification to create Test Requirements.

The measurement results returned by the Test System are compared - without any modification - against the Test Requirements as defined by the shared risk principle.

The Shared Risk principle is defined in ITU-R M.1545 [3].

### 4.2 Applicability of minimum requirements

- a) In this specification the Minimum Requirements are specified as general requirements and additional requirements. Where the Requirement is specified as a general requirement, the requirement is mandated to be met in all scenarios
- b) For specific scenarios for which an additional requirement is specified, in addition to meeting the general requirement, the UE is mandated to meet the additional requirements.
- c) The reference sensitivity power levels defined in subclause 7.3 are valid for the specified reference measurement channels.
- d) NOTE: Receiver sensitivity degradation may occur when:
  - 1) The UE simultaneously transmits and receives with bandwidth allocations less than the transmission bandwidth configuration (see Figure 5.6-1), and
  - 2) Any part of the downlink transmission bandwidth is within an uplink transmission bandwidth from the downlink center subcarrier.
- e) The spurious emissions power requirements are for the long term average of the power. For the purpose of reducing measurement uncertainty it is acceptable to average the measured power over a period of time sufficient to reduce the uncertainty due to the statistical nature of the signal.
- f) The requirements in this specification for TDD operating bands apply for downlink and uplink operations using Frame Structure Type 2 [4] except for Band 46 operating with Frame Structure Type 3.
- g) The requirements related to subslot TTI and/or slot TTI shall apply only if UE supports multiple TTI patterns. And these requirements only apply to subslot and/or slot TTI configurations

### 4.3 Void

#### 4.3A Applicability of minimum requirements (CA, UL-MIMO, ProSe, Dual Connectivity, UE category 0, UE category M1, UE category M2, UE category 1bis, UE category NB1 and NB2, V2X Communication, MBMS UE)

The requirements in clauses 5, 6 and 7 which are specific to CA, UL-MIMO, ProSe, Dual Connectivity, UE category 0, UE category M1, UE category M2, UE category 1bis, UE category NB1 and NB2 and V2X Communication are specified as suffix A, B, C, D, E, F and G where;

- a) Suffix A additional requirements need to support CA

- b) Suffix B additional requirements need to support UL-MIMO
- c) Suffix C additional requirements need to support Dual Connectivity
- d) Suffix D additional requirements need to support ProSe
- e) Suffix E additional requirements need to support UE category 0, category M1, category M2, and category 1bis
- f) Suffix F additional requirements need to support UE category NB1 and NB2
- g) Suffix G additional requirements need to support V2X Communication

A terminal which supports the above features needs to meet both the general requirements and the additional requirement applicable to the additional subclause (suffix A, B, C, D, E, F and G) in clauses 5, 6 and 7. Where there is a difference in requirement between the general requirements and the additional subclause requirements (suffix A, B, C, D, E, F and G) in clauses 5, 6 and 7, the tighter requirements are applicable unless stated otherwise in the additional subclause.

A terminal which supports more than one feature (CA, UL-MIMO, ProSe, Dual Connectivity, UE category 0, UE category M1, UE category M2, UE category 1bis, UE category NB1 and NB2 and V2X Communication) in clauses 5, 6 and 7 shall meet all of the separate corresponding requirements.

For a terminal supporting CA, compliance with minimum requirements for non-contiguous intra-band carrier aggregation in any given operating band does not imply compliance with minimum requirements for contiguous intra-band carrier aggregation in the same operating band.

For a terminal supporting CA, compliance with minimum requirements for contiguous intra-band carrier aggregation in any given operating band does not imply compliance with minimum requirements for non-contiguous intra-band carrier aggregation in the same operating band.

A terminal which supports a DL CA configuration shall support all the lower order fallback DL CA combinations and it shall support at least one bandwidth combination set for each of the constituent lower order DL combinations containing all the bandwidths specified within each specific combination set of the upper order DL combination.

A terminal which supports CA, for each supported CA configuration, shall support Pcell transmissions in each of the aggregated Component Carriers unless indicated otherwise in clause 5.6A.1.

Terminal supporting Dual Connectivity configuration shall meet the minimum requirements for corresponding CA configuration (suffix A), unless otherwise specified.

For a terminal that supports ProSe Direct Communication and/or ProSe Direct Discovery, the minimum requirements are applicable when

- the UE is associated with a serving cell on the ProSe carrier, or
- the UE is not associated with a serving cell on the ProSe carrier and is provisioned with the preconfigured radio parameters for ProSe Direct Communications and/or ProSe Direct Discovery that are associated with known Geographical Area, or
- the UE is associated with a serving cell on a carrier different than the ProSe carrier, and the radio parameters for ProSe Direct Discovery on the ProSe carrier are provided by the serving cell, or
- the UE is associated with a serving cell on a carrier different than the ProSe carrier, and has a non-serving cell selected on the ProSe carrier that supports ProSe Direct Discovery and/or ProSe Direct Communication.

When the ProSe UE is not associated with a serving cell on the ProSe carrier, and the UE does not have knowledge of its geographical area, or is provisioned with preconfigured radio parameters that are not associated with any Geographical Area, ProSe transmissions are not allowed, and the requirements in Section 6.3.3D apply.

A terminal that supports simultaneous E-UTRA ProSe sidelink transmissions and E-UTRA uplink transmissions for the inter-band E-UTRA ProSe/E-UTRA bands specified in Table 5.5D-2, shall meet the minimum requirements for the corresponding inter-band UL CA configuration (suffix A), unless otherwise specified. For transmitter characteristics specified in clause 6, the terminal is required to meet the conformance tests for the corresponding inter-band UL CA configuration and is not required to be retested with simultaneous E-UTRA ProSe sidelink and E-UTRA uplink transmissions.

A terminal that supports E-UTRA V2X intra-band multi-carrier operation including carrier aggregation for the band specified in Table 5.5G-3, shall meet the corresponding transmitter characteristics requirements (in subclauses with suffix G in Section 6) only when there are multiple active transmissions on all of the configured carrier components. When there is only one active transmission on one of the configured carrier components, the corresponding requirements for V2X single carrier operation apply for the corresponding active carrier component.

A terminal which supports MBMS (including 15 kHz, 7.5 kHz, 1.25 kHz, 2.5 kHz and 0.37 kHz subcarrier spacing), shall meet the minimum requirements in clauses 5 and 7. A terminal which supports MBMS is not required to support all kinds of subcarrier spacing.

A terminal that supports multiple TTI patterns in different carriers, different TTI patterns can only be used when the carriers are aggregated in inter-band manner. For intra-band carrier aggregation, only same TTI patterns and same TAG are allowed in aggregated carriers.

## 4.4 RF requirements in later releases

The standardisation of new frequency bands and carrier aggregation configurations (downlink and uplink aggregation) may be independent of a release. However, in order to implement a UE that conforms to a particular release but supports a band of operation or a carrier aggregation configuration that is specified in a later release, it is necessary to specify some extra requirements. TS 36.307 [8] specifies requirements on UEs supporting a frequency band or a carrier aggregation configuration that is independent of release.

NOTE: For UEs conforming to the 3GPP release of the present document, some RF requirements of later releases may be mandatory independent of whether the UE supports the bands specified or carrier aggregation configurations defined in later releases or not. The set of RF requirements of later releases that is also mandatory for UEs conforming to the 3GPP release of the present document is determined by regional regulation.

---

# 5 Operating bands and channel arrangement

## 5.1 General

The channel arrangements presented in this clause are based on the operating bands and channel bandwidths defined in the present release of specifications.

NOTE: Other operating bands and channel bandwidths may be considered in future releases.

## 5.2 Void

## 5.3 Void

## 5.4 Void

## 5.5 Operating bands

E-UTRA is designed to operate in the operating bands defined in Table 5.5-1.

**Table 5.5-1 E-UTRA operating bands**

E-UTRA Operating Band	Uplink (UL) operating band BS receive UE transmit		Downlink (DL) operating band BS transmit UE receive		Duplex Mode
	F <sub>UL</sub> low	F <sub>UL</sub> high	F <sub>DL</sub> low	F <sub>DL</sub> high	
1	1920 MHz	1980 MHz	2110 MHz	2170 MHz	FDD
2	1850 MHz	1910 MHz	1930 MHz	1990 MHz	FDD
3	1710 MHz	1785 MHz	1805 MHz	1880 MHz	FDD
4	1710 MHz	1755 MHz	2110 MHz	2155 MHz	FDD
5	824 MHz	849 MHz	869 MHz	894 MHz	FDD
6 <sup>1</sup>	830 MHz	840 MHz	875 MHz	885 MHz	FDD
7	2500 MHz	2570 MHz	2620 MHz	2690 MHz	FDD
8	880 MHz	915 MHz	925 MHz	960 MHz	FDD
9	1749.9 MHz	1784.9 MHz	1844.9 MHz	1879.9 MHz	FDD
10	1710 MHz	1770 MHz	2110 MHz	2170 MHz	FDD
11	1427.9 MHz	1447.9 MHz	1475.9 MHz	1495.9 MHz	FDD
12	699 MHz	716 MHz	729 MHz	746 MHz	FDD
13	777 MHz	787 MHz	746 MHz	756 MHz	FDD
14	788 MHz	798 MHz	758 MHz	768 MHz	FDD
15	Reserved		Reserved		FDD
16	Reserved		Reserved		FDD
17	704 MHz	716 MHz	734 MHz	746 MHz	FDD
18	815 MHz	830 MHz	860 MHz	875 MHz	FDD
19	830 MHz	845 MHz	875 MHz	890 MHz	FDD
20	832 MHz	862 MHz	791 MHz	821 MHz	FDD
21	1447.9 MHz	1462.9 MHz	1495.9 MHz	1510.9 MHz	FDD
22	3410 MHz	3490 MHz	3510 MHz	3590 MHz	FDD
23 <sup>1</sup>	2000 MHz	2020 MHz	2180 MHz	2200 MHz	FDD
24	1626.5 MHz	1660.5 MHz	1525 MHz	1559 MHz	FDD
25	1850 MHz	1915 MHz	1930 MHz	1995 MHz	FDD
26	814 MHz	849 MHz	859 MHz	894 MHz	FDD
27	807 MHz	824 MHz	852 MHz	869 MHz	FDD
28	703 MHz	748 MHz	758 MHz	803 MHz	FDD
29	N/A		717 MHz	728 MHz	FDD <sup>2</sup>
30 <sup>15</sup>	2305 MHz	2315 MHz	2350 MHz	2360 MHz	FDD
31	452.5 MHz	457.5 MHz	462.5 MHz	467.5 MHz	FDD
32	N/A		1452 MHz	1496 MHz	FDD <sup>2</sup>
33	1900 MHz	1920 MHz	1900 MHz	1920 MHz	TDD
34	2010 MHz	2025 MHz	2010 MHz	2025 MHz	TDD
35	1850 MHz	1910 MHz	1850 MHz	1910 MHz	TDD
36	1930 MHz	1990 MHz	1930 MHz	1990 MHz	TDD
37	1910 MHz	1930 MHz	1910 MHz	1930 MHz	TDD
38	2570 MHz	2620 MHz	2570 MHz	2620 MHz	TDD
39	1880 MHz	1920 MHz	1880 MHz	1920 MHz	TDD
40	2300 MHz	2400 MHz	2300 MHz	2400 MHz	TDD
41	2496 MHz	2690 MHz	2496 MHz	2690 MHz	TDD
42	3400 MHz	3600 MHz	3400 MHz	3600 MHz	TDD
43	3600 MHz	3800 MHz	3600 MHz	3800 MHz	TDD
44	703 MHz	803 MHz	703 MHz	803 MHz	TDD
45	1447 MHz	1467 MHz	1447 MHz	1467 MHz	TDD
46	5150 MHz	5925 MHz	5150 MHz	5925 MHz	TDD <sup>8</sup>
47	5855 MHz	5925 MHz	5855 MHz	5925 MHz	TDD <sup>11</sup>
48	3550 MHz	3700 MHz	3550 MHz	3700 MHz	TDD
49	3550 MHz	3700 MHz	3550 MHz	3700 MHz	TDD <sup>16</sup>
50	1432 MHz	1517 MHz	1432 MHz	1517 MHz	TDD <sup>13</sup>
51	1427 MHz	1432 MHz	1427 MHz	1432 MHz	TDD <sup>13</sup>
52	3300 MHz	3400 MHz	3300 MHz	3400 MHz	TDD
53	2483.5 MHz	2495 MHz	2483.5 MHz	2495 MHz	TDD
...					
64	Reserved				
65	1920 MHz	2010 MHz	2110 MHz	2200 MHz	FDD
66	1710 MHz	1780 MHz	2110 MHz	2200 MHz	FDD <sup>4</sup>

67	N/A	738 MHz – 758 MHz	FDD <sup>2</sup>
68	698 MHz – 728 MHz	753 MHz – 783 MHz	FDD
69	N/A	2570 MHz – 2620 MHz	FDD <sup>2</sup>
70	1695 MHz – 1710 MHz	1995 MHz – 2020 MHz	FDD <sup>10</sup>
71	663 MHz – 698 MHz	617 MHz – 652 MHz	FDD
72	451 MHz – 456 MHz	461 MHz – 466 MHz	FDD
73	450 MHz – 455 MHz	460 MHz – 465 MHz	FDD
74	1427 MHz – 1470 MHz	1475 MHz – 1518 MHz	FDD
75	N/A	1432 MHz – 1517 MHz	FDD <sup>2</sup>
76	N/A	1427 MHz – 1432 MHz	FDD <sup>2</sup>
85	698 MHz – 716 MHz	728 MHz – 746 MHz	FDD
87	410 MHz – 415 MHz	420 MHz – 425 MHz	FDD
88	412 MHz – 417 MHz	422 MHz – 427 MHz	FDD
<p>NOTE 1: Band 6, 23 is not applicable</p> <p>NOTE 2: Restricted to E-UTRA operation when carrier aggregation is configured. The downlink operating band is paired with the uplink operating band (external) of the carrier aggregation configuration that is supporting the configured Pcell.</p> <p>NOTE 3: A UE that complies with the E-UTRA Band 65 minimum requirements in this specification shall also comply with the E-UTRA Band 1 minimum requirements.</p> <p>NOTE 4: The range 2180-2200 MHz of the DL operating band is restricted to E-UTRA operation when carrier aggregation is configured.</p> <p>NOTE 5: A UE that supports E-UTRA Band 66 shall receive in the entire DL operating band</p> <p>NOTE 6: A UE that supports E-UTRA Band 66 and CA operation in any CA band shall also comply with the minimum requirements specified for the DL CA configurations CA_66B, CA_66C and CA_66A-66A.</p> <p>NOTE 7: A UE that complies with the E-UTRA Band 66 minimum requirements in this specification shall also comply with the E-UTRA Band 4 minimum requirements.</p> <p>NOTE 8: This band is an unlicensed band restricted to licensed-assisted operation using Frame Structure Type 3</p> <p>NOTE 9: In this version of the specification, restricted to E-UTRA DL operation when carrier aggregation is configured.</p> <p>NOTE 10: The range 2010-2020 MHz of the DL operating band is restricted to E-UTRA operation when carrier aggregation is configured and TX-RX separation is 300 MHz The range 2005-2020 MHz of the DL operating band is restricted to E-UTRA operation when carrier aggregation is configured and TX-RX separation is 295 MHz.</p> <p>NOTE 11: This band is unlicensed band used for V2X communication. There is no expected network deployment in this band so Frame Structure Type 1 is used.</p> <p>NOTE 12: A UE that complies with the E-UTRA Band 74 minimum requirements in this specification shall also comply with the E-UTRA Band 11 and Band 21 minimum requirements.</p> <p>NOTE 13: UE that complies with the E-UTRA Band 50 minimum requirements in this specification shall also comply with the E-UTRA Band 51 minimum requirements.</p> <p>NOTE 14: A UE that complies with the E-UTRA Band 75 minimum requirements in this specification shall also comply with the E-UTRA Band 76 minimum requirements.</p> <p>NOTE 15: Uplink transmission is not allowed at this band for UE with external vehicle-mounted antennas.</p> <p>NOTE 16: This band is restricted to licensed-assisted operation using Frame Structure Type 3</p>			

## 5.5A Operating bands for CA

E-UTRA carrier aggregation is designed to operate in the operating bands defined in Tables 5.5A-1, 5.5A-2, 5.5A-2a, 5.5A-2b, 5.5A-2c and 5.5A-3.

**Table 5.5A-1: Intra-band contiguous CA operating bands**

<b>E-UTRA CA Band</b>	<b>E-UTRA Band (Table 5.5.1)</b>
CA_1	1
CA_2	2
CA_3	3
CA_5	5
CA_7	7
CA_8	8
CA_12	12
CA_23	23
CA_27	27
CA_28	28
CA_38	38
CA_39	39
CA_40	40
CA_41	41
CA_42	42
CA_43	43
CA_48	48
CA_66	66
CA_70	70



**Table 5.5A-2: Inter-band CA operating bands (two bands)**

E-UTRA CA Band	E-UTRA Band (Table 5.5.1)
CA_1-3	1, 3
CA_1-1-3	1,3
CA_1-1-5	1,5
CA_1-1-7	1,7
CA_1-1-28	1,28
CA_1-3-3	1, 3
CA_1-5	1, 5
CA_1-7	1, 7
CA_1-7-7	1, 7
CA_1-8	1, 8
CA_1-11	1, 11
CA_1-18	1, 18
CA_1-19	1, 19
CA_1-20	1, 20
CA_1-21	1, 21
CA_1-26	1, 26
CA_1-28	1, 28
CA_1-32	1, 32
CA_1-38	1, 38
CA_1-40	1, 40
CA_1-41	1, 41
CA_1-42	1, 42
CA_1-42-42	1, 42
CA_1-43	1, 43
CA_1-46	1, 46
CA_2-4	2, 4
CA_2-2-4	2, 4
CA_2-2-4-4	2, 4
CA_2-4-4	2, 4
CA_2-5	2, 5
CA_2-2-5	2, 5
CA_2-2-7	2, 7
CA_2-7	2, 7
CA_2-7-7	2, 7
CA_2-12	2, 12
CA_2-2-12	2, 12
CA_2-2-12-12	2, 12
CA_2-2-29	2, 29
CA_2-12-12	2, 12
CA_2-13	2, 13
CA_2-2-13	2, 13
CA_2-14	2, 14
CA_2-2-14	2, 14
CA_2-17	2, 17
CA_2-26	2, 26
CA_2-28	2, 28
CA_2-29	2, 29
CA_2-30	2, 30
CA_2-2-30	2, 30
CA_2-46	2, 46
CA_2-2-46	2, 46
CA_2-46-46	2, 46
CA_2-48-48	2, 48
CA_2-49	2, 49
CA_2-66	2, 66

CA_2-48	2, 48
CA_2-2-66	2, 66
CA_2-2-66-66	2, 66
CA_2-66-66	2, 66
CA_2-66-66-66	2, 66
CA_2-71	2, 71
CA_2-2-71	2, 71
CA_3-5	3, 5
CA_3-3-5	3, 3, 5
CA_3-7	3, 7
CA_3-3-7	3, 7
CA_3-3-7-7	3, 7
CA_3-7-7	3, 7
CA_3-8	3, 8
CA_3-3-8	3, 8
CA_3-11	3, 11
CA_3-18	3, 18
CA_3-19	3, 19
CA_3-3-19	3, 19
CA_3-20	3, 20
CA_3-3-20	3, 20
CA_3-3-21	3, 21
CA_3-3-28	3, 28
CA_3-3-41	3, 41
CA_3-3-42	3, 42
CA_3-21	3, 21
CA_3-26	3, 26
CA_3-27	3, 27
CA_3-28	3, 28
CA_3-31	3, 31
CA_3-32	3, 32
CA_3-38	3, 38
CA_3-40	3, 40
CA_3-40-40	3, 40
CA_3-41	3, 41
CA_3-42	3, 42
CA_3-42-42	3, 42
CA_3-43	3, 43
CA_3-46	3, 46
CA_3-3-46	3, 46
CA_3-69	3, 69
CA_4-5	4, 5
CA_4-4-5	4, 5
CA_4-7	4, 7
CA_4-4-7	4, 7
CA_4-7-7	4, 7
CA_4-12	4, 12
CA_4-4-12	4, 12
CA_4-4-12-12	4, 12
CA_4-12-12	4, 12
CA_4-13	4, 13
CA_4-4-13	4, 13
CA_4-17	4, 17
CA_4-27	4, 27
CA_4-28	4, 28
CA_4-29	4, 29
CA_4-4-29	4, 29

CA_4-30	4, 30
CA_4-4-30	4, 30
CA_4-46	4, 46
CA_4-46-46	4, 46
CA_4-48	4, 48
CA_4-71	4, 71
CA_4-4-71	4, 71
CA_5-5-40	5, 40
CA_5-7	5, 7
CA_5-7-7	5, 7
CA_5-12	5, 12
CA_5-12-12	5, 12
CA_5-13	5, 13
CA_5-17	5, 17
CA_5-25	5, 25
CA_5-28	5, 28
CA_5-29	5, 29
CA_5-30	5, 30
CA_5-38	5, 38
CA_5-40	5, 40
CA_5-40-40	5, 40
CA_5-41	5, 41
CA_5-46	5, 46
CA_5-48	5, 48
CA_5-66	5, 66
CA_5-5-66	5, 66
CA_5-66-66	5, 66
CA_5-5-66-66	5, 66
CA_7-8	7, 8
CA_7-7-8	7, 8
CA_7-12	7, 12
CA_7-20	7, 20
CA_7-22	7, 22
CA_7-26	7, 26
CA_7-7-26	7, 26
CA_7-28	7, 28
CA_7-7-28	7, 28
CA_7-29	7, 29
CA_7-7-29	7, 29
CA_7-30	7, 30
CA_7-32	7, 32
CA_7-40	7, 40
CA_7-42	7, 42
CA_7-42-42	7, 42
CA_7-46	7, 46
CA_7-7-46	7, 46
CA_7-7-66	7, 66
CA_7-66	7, 66
CA_7-66-66	7, 66
CA_7-7-66-66	7, 66
CA_8-11	8, 11
CA_8-20	8, 20
CA_8-27	8, 27
CA_8-28	8, 28
CA_8-32	8, 32
CA_8-38	8, 38
CA_8-39	8, 39

CA_8-40	8, 40
CA_8-41	8, 41
CA_8-42	8, 42
CA_8-46	8, 46
CA_11-18	11, 18
CA_11-26	11, 26
CA_11-28	11, 28
CA_11-41	11, 41
CA_11-42	11, 42
CA_11-46	11, 46
CA_12-25	12, 25
CA_12-30	12, 30
CA_12-46	12, 46
CA_12-48	12, 48
CA_12-48	12, 48
CA_12-66	12, 66
CA_12-66-66	12, 66
CA_13-46	13, 46
CA_13-46-46	13, 46
CA_13-48	13, 48
CA_13-48-48	13, 48
CA_13-66	13, 66
CA_13-66-66	13, 66
CA_14-66	14, 66
CA_14-66-66	14, 66
CA_14-66-66-66	14, 66
CA_14-30	14, 30
CA_18-28 <sup>1</sup>	18, 28
CA_18-42	18, 42
CA_19-21	19, 21
CA_19-28 <sup>2</sup>	19, 28
CA_19-42	19, 42
CA_19-46	19, 46
CA_20-28 <sup>1</sup>	20, 28
CA_20-31	20, 31
CA_20-32	20, 32
CA_20-38	20, 38
CA_20-40	20, 40
CA_20-40-40	20, 40
CA_20-42	20, 42
CA_20-42-42	20, 42
CA_20-43	20, 43
CA_20-67	20, 67
CA_20-75	20, 75
CA_20-76	20, 76
CA_21-28	21, 28
CA_21-42	21, 42
CA_21-46	21, 46
CA_23-29	23, 29
CA_25-26	25, 26
CA_25-25-26	25, 26
CA_25-41	25, 41
CA_25-25-41	25, 41
CA_25-46	25, 46
CA_26-41	26, 41
CA_26-46	26, 46
CA_26-48	26,48

CA_26-48-48	26,48
CA_26-66	26, 66
CA_28-32	28, 32
CA_28-38	28,38
CA_28-40	28, 40
CA_28-41	28, 41
CA_28-42	28, 42
CA_28-42-42	28, 42
CA_28-46	28, 46
CA_28-66	28, 66
CA_29-30	29, 30
CA_29-66	29, 66
CA_29-66-66	29, 66
CA_29-70	29, 70
CA_30-66	30, 66
CA_30-66-66	30, 66
CA_32-42	32, 42
CA_32-43	32, 43
CA_34-39	34, 39
CA_34-41	34, 41
CA_38-40	38, 40
CA_38-40-40	38, 40
CA_39-41	39, 41
CA_39-40	39, 40
CA_39-42	39, 42
CA_39-46	39, 46
CA_40-41	40, 41
CA_40-42	40, 42
CA_40-43	40, 43
CA_40-46	40, 46
CA_41-42	41, 42
CA_41-42-42	41, 42
CA_41-46	41, 46
CA_41-48	41, 48
CA_42-43	42,43
CA_42-46	42, 46
CA_46-48	46, 48
CA_46-48-48	46, 48
CA_46-66	46, 66
CA_46-46-66	46, 66
CA_46-66-66	46, 66
CA_46-70	46, 70
CA_46-71	46, 71
CA_48-66	48, 66
CA_48-66-66	48, 66
CA_48-48-66-66	48, 66
CA_48-48-66	48, 66
CA_48-71	48, 71
CA_48-48-71	48, 71
CA_66-70	66,70
CA_66-66-70	66,70
CA_66-71	66, 71
CA_66-66-71	66, 71
CA_70-71	70, 71

NOTE 1: The frequency range in band 28 is restricted for this CA band combination to 703-733 MHz for the UL and 758-788 MHz for the DL

NOTE 2: The frequency range in band 28 is restricted for this CA band combination to 718-748 MHz for the UL and 773-803 MHz for the DL

**Table 5.5A-2a: Inter-band CA operating bands (three bands)**



E-UTRA CA Band	E-UTRA Band (Table 5.5.1)
CA_1-3-5	1, 3, 5
CA_1-3-3-5	1, 3, 5
CA_1-1-3-5	1, 3, 5
CA_1-1-3-7	1, 3, 7
CA_1-1-3-3-7	1, 3, 7
CA_1-3-7	1, 3, 7
CA_1-3-3-7	1, 3, 7
CA_1-3-3-7-7	1, 3, 7
CA_1-3-7-7	1, 3, 7
CA_1-3-8	1, 3, 8
CA_1-3-3-8	1, 3, 8
CA_1-3-3-43	1, 3, 43
CA_1-3-11	1, 3, 11
CA_1-3-18	1, 3, 18
CA_1-3-19	1, 3, 19
CA_1-3-3-19	1, 3, 19
CA_1-3-20	1, 3, 20
CA_1-3-3-20	1, 3, 20
CA_1-3-21	1, 3, 21
CA_1-3-3-21	1, 3, 21
CA_1-3-26	1, 3, 26
CA_1-3-28	1, 3, 28
CA_1-3-3-28	1, 3, 28
CA_1-1-3-28	1, 3, 28
CA_1-1-3-3-28	1, 3, 28
CA_1-3-32	1, 3, 32
CA_1-3-38	1, 3, 38
CA_1-3-40	1, 3, 40
CA_1-3-41	1, 3, 41
CA_1-3-42	1, 3, 42
CA_1-3-3-42	1, 3, 42
CA_1-3-42-42	1, 3, 42
CA_1-3-43	1, 3, 43
CA_1-3-46	1, 3, 46
CA_1-5-7	1, 5, 7
CA_1-5-7-7	1, 5, 7
CA_1-5-28 <sup>2</sup>	1, 5, 28
CA_1-5-40	1, 5, 40
CA_1-5-41	1, 5, 41
CA_1-5-46	1, 5, 46
CA_1-7-8	1, 7, 8
CA_1-7-7-8	1, 7, 8
CA_1-7-20	1, 7, 20
CA_1-7-7-20	1, 7, 20
CA_1-7-26	1, 7, 26
CA_1-7-7-26	1, 7, 26
CA_1-7-28	1, 7, 28
CA_1-7-32	1, 7, 32
CA_1-7-38	1, 7, 38
CA_1-7-40	1, 7, 40
CA_1-7-42	1, 7, 42
CA_1-7-46	1, 7, 46
CA_1-8-11	1, 8, 11
CA_1-8-20	1, 8, 20
CA_1-8-28	1, 8, 28
CA_1-8-38	1, 8, 38
CA_1-8-40	1, 8, 40
CA_1-8-42	1, 8, 42
CA_1-11-18	1, 11, 18
CA_1-11-28	1, 11, 28
CA_1-11-42	1, 11, 42
CA_1-18-28 <sup>1</sup>	1, 18, 28
CA_1-18-41	1, 18, 41

CA_1-18-42	1, 18, 42
CA_1-19-21	1, 19, 21
CA_1-19-28 <sup>2</sup>	1, 19, 28
CA_1-19-42	1, 19, 42
CA_1-20-28 <sup>1</sup>	1, 20, 28
CA_1-20-32	1, 20, 32
CA_1-20-38	1, 20, 38
CA_1-20-42	1, 20, 42
CA_1-20-43	1, 20, 43
CA_1-21-28	1, 21, 28
CA_1-21-42	1, 21, 42
CA_1-28-40	1, 28, 40
CA_1-28-42	1, 28, 42
CA_1-32-42	1, 32, 42
CA_1-32-43	1, 32, 43
CA_1-41-42	1, 41, 42
CA_1-42-42	1, 42, 42
CA_1-42-43	1, 42, 43
CA_2-4-5	2, 4, 5
CA_2-2-4-5	2, 4, 5
CA_2-4-4-5	2, 4, 5
CA_2-4-12-12	2, 4, 12
CA_2-5-12-12	2, 5, 12
CA_2-2-5-30	2, 5, 30
CA_2-5-46	2, 5, 46
CA_2-2-5-66	2, 5, 66
CA_2-2-7-12	2, 7, 12
CA_2-2-7-66	2, 7, 66
CA_2-7-66-66	2, 7, 66
CA_2-2-12-30	2, 12, 30
CA_2-2-12-66	2, 12, 66
CA_2-2-12-66-66	2, 12, 66
CA_2-2-13-66	2, 13, 66
CA_2-2-14-66-66	2, 14, 66
CA_2-2-30-66	2, 30, 66
CA_2-4-7	2, 4, 7
CA_2-4-7-7	2, 4, 7
CA_2-4-12	2, 4, 12
CA_2-2-4-12	2, 4, 12
CA_2-2-5-66-66	2, 5, 66
CA_2-4-4-12	2, 4, 12
CA_2-4-13	2, 4, 13
CA_2-4-28	2, 4, 28
CA_2-4-29	2, 4, 29
CA_2-4-30	2, 4, 30
CA_2-4-71	2, 4, 71
CA_2-2-4-71	2, 4, 71
CA_2-5-7	2, 5, 7
CA_2-5-12	2, 5, 12
CA_2-2-5-12	2, 5, 12
CA_2-5-13	2, 5, 13
CA_2-5-28	2, 5, 28
CA_2-5-29	2, 5, 29
CA_2-5-30	2, 5, 30
CA_2-5-46	2, 5, 46
CA_2-5-66	2, 5, 66
CA_2-5-66-66	2, 5, 66
CA_2-7-12	2, 7, 12
CA_2-7-13	2, 7, 13
CA_2-7-26	2, 7, 26
CA_2-7-28	2, 7, 28
CA_2-7-29	2, 7, 29
CA_2-7-30	2, 7, 30
CA_2-7-46	2, 7, 46
CA_2-7-66	2, 7, 66

CA_2-7-7-66	2, 7, 66
CA_2-7-66-66	2, 7, 66
CA_2-7-7-66-66	2, 7, 66
CA_2-12-30	2, 12, 30
CA_2-12-66	2, 12, 66
CA_2-12-66-66	2, 12, 66
CA_2-13-46	2, 13, 46
CA_2-13-48	2, 13, 48
CA_2-13-48-48	2, 13, 48
CA_2-13-66	2, 13, 66
CA_2-13-66-66	2, 13, 66
CA_2-14-30	2, 14, 30
CA_2-2-14-30	2, 14, 30
CA_2-14-66	2, 14, 66
CA_2-2-14-66	2, 14, 66
CA_2-14-66-66	2, 14, 66
CA_2-14-66-66-66	2, 14, 66
CA_2-26-66	2, 26, 66
CA_2-28-66	2, 28, 66
CA_2-2-29-30	2, 29, 30
CA_2-29-30	2, 29, 30
CA_2-29-66	2, 29, 66
CA_2-30-66	2, 30, 66
CA_2-30-66-66	2, 30, 66
CA_2-46-48	2, 46, 48
CA_2-46-66	2, 46, 66
CA_2-46-46-66	2, 46, 66
CA_2-48-66	2, 48, 66
CA_2-48-48-66	2, 48, 66
CA_2-66-71	2, 66, 71
CA_2-2-66-71	2, 66, 71
CA_2-66-66-71	2, 66, 71
CA_3-5-7	3, 5, 7
CA_3-5-7-7	3, 5, 7
CA_3-5-28	3, 5, 28
CA_3-3-5-28 <sup>2</sup>	3, 5, 28
CA_3-5-40	3, 5, 40
CA_3-5-40-40	3, 5, 40
CA_3-5-41	3, 5, 41
CA_3-3-7-8	3, 7, 8
CA_3-3-7-7-8	3, 7, 8
CA_3-7-7-8	3, 7, 8
CA_3-7-8	3, 7, 8
CA_3-7-20	3, 7, 20
CA_3-3-7-20	3, 7, 20
CA_3-7-7-20	3, 7, 20
CA_3-7-26	3, 7, 26
CA_3-7-7-26	3, 7, 26
CA_3-7-28	3, 7, 28
CA_3-3-7-28	3, 7, 28
CA_3-7-32	3, 7, 32
CA_3-7-38	3, 7, 38
CA_3-7-40	3, 7, 40
CA_3-7-42	3, 7, 42
CA_3-7-46	3, 7, 46
CA_3-8-11	3, 8, 11
CA_3-8-20	3, 8, 20
CA_3-8-28	3, 8, 28
CA_3-8-32	3, 8, 32
CA_3-8-38	3, 8, 38
CA_3-8-40	3, 8, 40
CA_3-8-42	3, 8, 42
CA_3-11-18	3, 11, 18
CA_3-11-26	3, 11, 26
CA_3-11-28	3, 11, 28

CA_3-18-42	3, 18, 42
CA_3-19-21	3, 19, 21
CA_3-3-19-21	3, 19, 21
CA_3-19-42	3, 19, 42
CA_3-20-28 <sup>1</sup>	3, 20, 28
CA_3-3-20-28 <sup>1</sup>	3, 20, 28
CA_3-20-32	3, 20, 32
CA_3-20-42	3, 20, 42
CA_3-20-43	3, 20, 43
CA_3-21-28	3, 21, 28
CA_3-21-42	3, 21, 42
CA_3-28-38	3, 28, 38
CA_3-28-40	3, 28, 40
CA_3-28-41	3, 28, 41
CA_3-28-42	3, 28, 42
CA_3-28-42-42	3, 28, 42
CA_3-32-42	3, 32, 42
CA_3-32-43	3, 32, 43
CA_3-32-46	3, 32, 46
CA_3-41-42	3, 41, 42
CA_3-41-42-42	3, 41, 42
CA_3-42-43	3, 42, 43
CA_4-5-12	4, 5, 12
CA_4-4-5-12	4, 5, 12
CA_4-5-12-12	4, 5, 12
CA_4-5-13	4, 5, 13
CA_4-5-29	4, 5, 29
CA_4-5-30	4, 5, 30
CA_4-4-5-30	4, 5, 30
CA_4-7-12	4, 7, 12
CA_4-7-28	4, 7, 28
CA_4-12-30	4, 12, 30
CA_4-4-12-30	4, 12, 30
CA_4-29-30	4, 29, 30
CA_4-4-29-30	4, 29, 30
CA_5-7-28	5, 7, 28
CA_5-7-46	5, 7, 46
CA_5-7-66	5, 7, 66
CA_5-7-66-66	5, 7, 66, 66
CA_5-12-46	5, 12, 46
CA_5-12-48	5, 12, 48
CA_5-12-66	5, 12, 66
CA_5-30-66	5, 30, 66
CA_5-30-66-66	5, 30, 66
CA_5-40-41	5, 40, 41
CA_5-46-66	5, 46, 66
CA_5-46-66-66	5, 46, 66
CA_5-48-66	5, 48, 66
CA_5-48-66-66	5, 48, 66
CA_7-8-20	7, 8, 20
CA_7-8-38	7, 8, 38
CA_7-8-40	7, 8, 40
CA_7-12-66	7, 12, 66
CA_7-13-66	7, 13, 66
CA_7-20-28 <sup>1</sup>	7, 20, 28
CA_7-20-32	7, 20, 32
CA_7-20-38	7, 20, 38
CA_7-20-42	7, 20, 42
CA_7-26-66	7, 26, 66
CA_7-28-38	7, 28, 38
CA_7-28-40	7, 28, 40
CA_7-29-66	7, 29, 66
CA_7-7-29-66	7, 29, 66
CA_7-30-66	7, 30, 66
CA_7-32-46	7, 32, 46

CA_7-46-66	7, 46, 66
CA_8-11-28	8, 11, 28
CA_8-11-42	8, 11, 42
CA_8-20-28 <sup>1</sup>	8, 20, 28
CA_8-28-41	8, 28, 41
CA_8-39-41	8, 39, 41
CA_12-30-66	12, 30, 66
CA_12-30-66-66	12, 30, 66
CA_13-46-66	13, 46, 66
CA_13-48-66	13, 48, 66
CA_13-48-48-66	13, 48, 66
CA_14-30-66	14, 30, 66
CA_14-30-66-66	14, 30, 66
CA_19-21-42	19, 21, 42
CA_20-32-42	20, 32, 42
CA_20-32-43	20, 32, 43
CA_20-38-40	20, 38, 40
CA_25-26-41	25, 26, 41
CA_25-25-26-41	25, 26, 41
CA_20-38-40-40	20, 38, 40
CA_21-28-42	21, 28, 42
CA_29-30-66-66	29, 30, 66
CA_28-41-42	28, 41, 42
CA_28-41-42-42	28, 41, 42
CA_29-30-66	29, 30, 66
CA_29-46-66	29, 46, 66
CA_29-66-70	29, 66, 70
CA_29-66-66-70	29, 66, 70
CA_32-42-43	32, 42, 43
CA_46-48-66	46, 48, 66
CA_46-48-71	46, 48, 71
CA_46-48-48-71	46, 48, 71
CA_66-70-71	66, 70, 71
CA_66-66-70-71	66, 70, 71
NOTE 1: The frequency range in band 28 is restricted for this CA band combination to 703-733 MHz for the UL and 758-788 MHz for the DL	
NOTE 2: The frequency range in band 28 is restricted for this CA band combination to 718-748 MHz for the UL and 773-803 MHz for the DL	

**Table 5.5A-2b: Inter-band CA operating bands (four bands)**

E-UTRA CA Band	E-UTRA Band (Table 5.5)
CA 1-3-5-7	1, 3, 5, 7
CA 1-3-3-5-7	1, 3, 5, 7
CA 1-3-5-7-7	1, 3, 5, 7
CA 1-3-5-28 <sup>2</sup>	1, 3, 5, 28
CA 1-3-5-40	1, 3, 5, 40
CA 1-3-5-41	1, 3, 5, 41
CA 1-3-7-7-26	1, 3, 7, 26
CA 1-3-7-8	1, 3, 7, 8
CA 1-3-3-7-8	1, 3, 7, 8
CA 1-3-7-7-8	1, 3, 7, 8
CA 1-3-3-7-7-8	1, 3, 7, 8
CA 1-3-7-20	1, 3, 7, 20
CA 1-3-7-7-20	1, 3, 7, 20
CA 1-3-3-7-20	1, 3, 7, 20
CA 1-3-7-26	1, 3, 7, 26
CA 1-3-7-28	1, 3, 7, 28
CA 1-1-3-7-28	1, 3, 7, 28
CA 1-3-3-7-28	1, 3, 7, 28
CA 1-1-3-3-7-28	1, 3, 7, 28
CA 1-3-7-28	1, 3, 7, 28
CA 1-3-7-32	1, 3, 7, 32
CA 1-3-7-40	1, 3, 7, 40
CA 1-3-7-42	1, 3, 7, 42
CA 1-3-7-46	1, 3, 7, 46
CA 1-3-8-11	1, 3, 8, 11
CA 1-3-8-20	1, 3, 8, 20
CA 1-3-8-28	1, 3, 8, 28
CA 1-3-8-38	1, 3, 8, 38
CA 1-3-11-28	1, 3, 11, 28
CA 1-3-8-40	1, 3, 8, 40
CA 1-3-8-42	1, 3, 8, 42
CA 1-3-18-42	1, 3, 18, 42
CA 1-3-19-21	1, 3, 19, 21
CA 1-3-3-19-21	1, 3, 19, 21
CA 1-3-19-42	1, 3, 19, 42
CA 1-3-20-28 <sup>1</sup>	1, 3, 20, 28
CA 1-3-3-20-28	1, 3, 20, 28
CA 1-3-20-32	1, 3, 20, 32
CA 1-3-20-42	1, 3, 20, 42
CA 1-3-20-43	1, 3, 20, 43
CA 1-3-21-28	1, 3, 21, 28
CA 1-3-21-42	1, 3, 21, 42
CA 1-3-28-40	1, 3, 28, 40
CA 1-3-28-42	1, 3, 28, 42
CA 1-3-32-42	1, 3, 32, 42
CA 1-3-32-43	1, 3, 32, 43
CA 1-3-41-42	1, 3, 41, 42
CA 1-3-42-43	1, 3, 42, 43
CA 1-5-7-28 <sup>2</sup>	1, 5, 7, 28
CA 1-5-7-46	1, 5, 7, 46
CA 1-7-8-20	1, 7, 8, 20
CA 1-7-8-40	1, 7, 8, 40
CA 1-7-20-28 <sup>1</sup>	1, 7, 20, 28
CA 1-7-20-32	1, 7, 20, 32
CA 1-7-20-42	1, 7, 20, 42
CA 1-7-28-40	1, 7, 28, 40
CA 1-8-11-28	1, 8, 11, 28
CA 1-8-11-42	1, 8, 11, 42
CA 1-8-20-28	1, 8, 20, 28

CA_1-19-21-42	1, 19, 21, 42
CA_1-20-32-42	1, 20, 32, 42
CA_1-20-32-43	1, 20, 32, 43
CA_1-21-28-42	1, 21, 28, 42
CA_1-32-42-43	1, 32, 42, 43
CA_2-2-5-12-66	2, 5, 12, 66
CA_2-2-5-30-66	2, 5, 30, 66
CA_2-2-7-12-66	2, 7, 12, 66
CA_2-2-12-30-66	2, 12, 30, 66
CA_2-2-14-30-66	2, 14, 30, 66
CA_2-4-5-12	2, 4, 5, 12
CA_2-4-5-29	2, 4, 5, 29
CA_2-4-5-30	2, 4, 5, 30
CA_2-4-7-12	2, 4, 7, 12
CA_2-4-12-30	2, 4, 12, 30
CA_2-4-29-30	2, 4, 29, 30
CA_2-5-7-28	2, 5, 7, 28
CA_2-5-12-66	2, 5, 12, 66
CA_2-5-30-66	2, 5, 30, 66
CA_2-5-30-66-66	2, 5, 30, 66
CA_2-7-12-66	2, 7, 12, 66
CA_2-7-13-66	2, 7, 13, 66
CA_2-7-26-66	2, 7, 26, 66
CA_2-7-29-66	2, 7, 29, 66
CA_2-7-7-29-66	2, 7, 29, 66
CA_2-7-46-66	2, 7, 46, 66
CA_2-12-30-66	2, 12, 30, 66
CA_2-12-30-66-66	2, 12, 30, 66
CA_2-13-48-66	2, 13, 48, 66
CA_2-13-48-48-66	2, 13, 48, 66
CA_2-14-30-66	2, 14, 30, 66
CA_2-14-30-66-66	2, 14, 30, 66
CA_2-29-30-66	2, 29, 30, 66
CA_2-46-48-66	2, 46, 48, 66
CA_3-5-7-28 <sup>2</sup>	3, 5, 7, 28
CA_3-3-5-7-28 <sup>2</sup>	3, 5, 7, 28
CA_3-7-8-20	3, 7, 8, 20
CA_3-7-8-38	3, 7, 8, 38
CA_3-7-8-40	3, 7, 8, 40
CA_3-7-20-28 <sup>1</sup>	3, 7, 20, 28
CA_3-7-20-32	3, 7, 20, 32
CA_3-7-20-42	3, 7, 20, 42
CA_3-7-28-38	3, 7, 28, 38
CA_3-7-28-40	3, 7, 28, 40
CA_3-7-32-46	3, 7, 32, 46
CA_3-8-11-28	3, 8, 11, 28
CA_3-8-20-28	3, 8, 20, 28
CA_3-19-21-42	3, 19, 21, 42
CA_3-20-32-42	3, 20, 32, 42
CA_3-20-32-43	3, 20, 32, 43
CA_3-21-28-42	3, 21, 28, 42
CA_3-28-41-42	3, 28, 41, 42
CA_3-32-42-43	3, 32, 42, 43
NOTE 1: The frequency range in band 28 is restricted for this CA band combination to 703-733 MHz for the UL and 758-788 MHz for the DL	
NOTE 2: The frequency range in band 28 is restricted for this CA band combination to 718-748 MHz for the UL and 773-803 MHz for the DL	



**Table 5.5A-2c: Inter-band CA operating bands (five bands)**

E-UTRA CA Band	E-UTRA Band (Table 5.5)
CA_1-3-5-7-28 <sup>2</sup>	1, 3, 5, 7, 28
CA_1-3-7-8-20	1, 3, 7, 8, 20
CA_1-3-7-20-28 <sup>1</sup>	1, 3, 7, 20, 28
CA_1-3-7-20-32	1, 3, 7, 20, 32
CA_1-3-7-20-42	1, 3, 7, 20, 42
CA_1-3-8-11-28	1, 3, 8, 11, 28
CA_1-3-20-32-42	1, 3, 20, 32, 42
CA_1-3-20-32-43	1, 3, 20, 32, 43
CA_1-3-32-42-43	1, 3, 32, 42, 43
NOTE 1: The frequency range in band 28 is restricted for this CA band combination to 703-733 MHz for the UL and 758-788 MHz for the DL	
NOTE 2: The frequency range in band 28 is restricted for this CA band combination to 718-748 MHz for the UL and 773-803 MHz for the DL	

**Table 5.5A-3: Intra-band non-contiguous CA operating bands (with two sub-blocks)**

E-UTRA CA Band	E-UTRA Band (Table 5.5)
CA_1-1	1
CA_2-2	2
CA_3-3	3
CA_4-4	4
CA_5-5	5
CA_7-7	7
CA_12-12	12
CA_23-23	23
CA_25-25	25
CA_40-40	40
CA_41-41	41
CA_42-42	42
CA_43-43	43
CA_48-48	48
CA_66-66	66

**Table 5.5A-4: Intra-band non-contiguous CA operating bands (with three sub-blocks)**

E-UTRA CA Band	E-UTRA Band (Table 5.5)
CA_25-25-25	25
CA_41-41-41	41
CA_48-48-48	48
CA_66-66-66	66

**Table 5.5A-5: Intra-band non-contiguous CA operating bands (with four sub-blocks)**

E-UTRA CA Band	E-UTRA Band (Table 5.5)
CA_48-48-48-48	48

## 5.5B Operating bands for UL-MIMO

E-UTRA UL-MIMO is designed to operate in the operating bands defined in Table 5.5B-1.

**Table 5.5B-1: Void**

## 5.5C Operating bands for Dual Connectivity

E-UTRA dual connectivity is designed to operate in the operating bands defined in Table 5.5C-1.

**Table 5.5C-1: Inter-band dual connectivity operating bands (two bands)**

E-UTRA DC Band	E-UTRA Band (Table 5.5)
DC_1-3	1, 3
DC_1-5	1, 5
DC_1-7	1, 7
DC_1-8	1, 8
DC_1-11	1, 11
DC_1-19	1, 19
DC_1-20	1, 20
DC_1-21	1, 21
DC_1-42	1, 42
DC_2-4	2, 4
DC_2-5	2, 5
DC_2-7	2, 7
DC_2-12	2, 12
DC_2-13	2, 13
DC_2-14	2, 14
DC_2-30	2, 30
DC_2-48	2, 48
DC_2-66	2, 66
DC_3-5	3, 5
DC_3-7	3, 7
DC_3-8	3, 8
DC_3-11	3, 11
DC_3-18	3, 18
DC_3-19	3, 19
DC_3-20	3, 20
DC_3-21	3, 21
DC_3-26	3, 26
DC_3-28	3, 28
DC_3-40	3, 40
DC_3-42	3, 42
DC_4-5	4, 5
DC_4-7	4, 7
DC_4-12	4, 12
DC_4-13	4, 13
DC_4-17	4, 17
DC_4-28	4, 28
DC_5-7	5, 7
DC_5-12	5, 12
DC_5-17	5, 17
DC_5-30	5, 30
DC_5-40	5, 40
DC_5-66	5, 66
DC_7-8	7, 8
DC_7-20	7, 20
DC_7-26	7, 26
DC_7-28	7, 28
DC_8-39	8, 39
DC_8-41	8, 41
DC_11-18	11, 18
DC_11-26	11, 26
DC_12-30	12, 30
DC_12-66	12, 66
DC_13-66	13, 66
DC_14-30	14, 30
DC_14-66	14, 66
DC_19-21	19, 21
DC_19-42	19, 42
DC_21-42	21, 42
DC_21-28	21, 28

DC_25-26	25, 26
DC_25-41	25, 41
DC_26-46	26, 46
DC_26-48	26, 48
DC_28-41	28, 41
DC_28-42	28, 42
DC_30-66	30, 66
DC_39-41	39, 41
DC_40-42	40, 42
DC_41-42	41, 42

Table 5.5C-2: Inter-band dual connectivity operating bands (three bands)

E-UTRA DC Band	E-UTRA Band (Table 5.5)
DC_1-3-19	1, 3, 19
DC_1-19-21	1, 19, 21

## 5.5D Operating bands for ProSe

E-UTRA ProSe is designed to operate in the operating bands defined in Table 5.5D-1.

Table 5.5D-1 E-UTRA ProSe operating band

E-UTRA ProSe Band	E-UTRA Operating Band	ProSe UE transmit		ProSe UE receive		ProSe Duplex Mode	ProSe Direct	
		F <sub>UL_low</sub>	F <sub>UL_high</sub>	F <sub>DL_low</sub>	F <sub>DL_high</sub>		Disc.	Comm.
2	2	1850 MHz	1910 MHz	1850 MHz	1910 MHz	HD	Yes	
3	3	1710 MHz	1785 MHz	1710 MHz	1785 MHz	HD	Yes	Yes
4	4	1710 MHz	1755 MHz	1710 MHz	1755 MHz	HD	Yes	
7	7	2500 MHz	2570 MHz	2500 MHz	2570 MHz	HD	Yes	Yes
14	14	788 MHz	798 MHz	788 MHz	798 MHz	HD	Yes	Yes
20	20	832 MHz	862 MHz	832 MHz	862 MHz	HD	Yes	Yes
26	26	814 MHz	849 MHz	814 MHz	849 MHz	HD	Yes	Yes
28	28	703 MHz	748 MHz	703 MHz	748 MHz	HD	Yes	Yes
31	31	452.5 MHz	457.5 MHz	452.5 MHz	457.5 MHz	HD	Yes	Yes
41	41	2496 MHz	2690 MHz	2496 MHz	2690 MHz	HD	Yes	
68	68	698 MHz	728 MHz	698 MHz	728 MHz	HD	Yes	Yes
72	72	451 MHz	456 MHz	451 MHz	456 MHz	HD	Yes	Yes

E-UTRA ProSe is designed to operate concurrent with E-UTRA uplink/downlink on the operating bands combinations listed in Table 5.5D-2.

Table 5.5D-2 Inter-band E-UTRA ProSe / E-UTRA operating bands

E-UTRA ProSe Band <sup>Note 1</sup>	E-UTRA band / E-UTRA CA band <sup>Note 2</sup>
2	4
	CA_2-4 <sup>Note 3</sup>
28	1
	CA_1-28 <sup>Note 3</sup>
NOTE 1: As specified in Table 5.5D-1 NOTE 2: As specified in Table 5.5-1 and Table 5.5A-2 NOTE 3: Applies when E-UTRA uplink is assigned to one E-UTRA band and ProSe operation is restricted to the uplink frequencies paired with either PCC or SCC. NOTE 4: The concurrency for E-UTRA ProSe Direct Discovery with E-UTRA uplink/downlink applies after allowing for any transmission and/or reception gap requested by the UE.	

## 5.5E Operating bands for UE category 0, UE category M1 and M2 and UE category 1bis

UE category 0 is designed to operate in the E-UTRA operating bands 2, 3, 4, 5, 8, 13, 20, 25, 26 and 28 in both half duplex FDD mode and full-duplex FDD mode and in bands 39, 40 and 41 in TDD mode. The E-UTRA bands are defined in Table 5.5-1.

UE category M1 and M2 is designed to operate in the E-UTRA operating bands 1, 2, 3, 4, 5, 7, 8, 11, 12, 13, 14, 18, 19, 20, 21, 25, 26, 27, 28, 31, 66, 71, 72, 73, 74, 85, 87 and 88 in both half duplex FDD mode and full-duplex FDD mode, and in bands 39, 40, 41, 42 and 43 in TDD mode. The E-UTRA bands are defined in Table 5.5-1.

UE category 1bis is designed to operate in the E-UTRA operating bands 1, 2, 3, 4, 5, 7, 8, 12, 13, 18, 20, 26, 28, 31, 66 and 72 in full duplex FDD mode and in bands 34, 39, 40 and 41 in TDD mode. The E-UTRA bands are defined in Table 5.5-1

## 5.5F Operating bands for category NB1 and NB2

Category NB1 and NB2 are designed to operate in the E-UTRA operating bands 1, 2, 3, 4, 5, 7, 8, 11, 12, 13, 14, 17, 18, 19, 20, 21, 25, 26, 28, 31, 41, 42, 43, 65, 66, 70, 71, 72, 73, 74, 85, 87 and 88 which are defined in Table 5.5-1.

Category NB1 and NB2 are designed to operate in the NR operating bands n1, n2, n3, n5, n7, n8, n12, n14, n18, n20, n25, n28, n41, n65, n66, n70, n71, n74, n90.

Category NB1 and NB2 systems operate in HD-FDD duplex mode or in TDD mode.

In case UE receives network signaling value NS\_04 on operating band 26 then the lower limit of band 26 uplink is 814.1 MHz and lower limit of downlink is 859.1 MHz to account for the PLMR emission requirement.

## 5.5G Operating bands for V2X Communication

E-UTRA V2X Communication is designed to operate in the the operating bands defined in Table 5.5G-1.

**Table 5.5G-1 V2X operating band**

E-UTRA Operating Band	E-UTRA V2X Operating Band	V2X UE transmit		V2X UE receive		Duplex Mode	Interface
		FUL_low	FUL_high	FDL_low	FDL_high		
47	47	5855 MHz	5925 MHz	5855 MHz	5925 MHz	HD	PC5

E-UTRA V2X communication is designed to operate concurrent with E-UTRA uplink/downlink on the operating bands combinations listed in Table 5.5G-2.

Table 5.5G-2 Inter-band con-current V2X operating bands

V2X con-current band configuration	E-UTRA or V2X Operating Band	Interface	Uplink (UL) operating band BS receive UE transmit		Downlink (DL) operating band BS transmit UE receive		Duplex Mode
			F <sub>UL, low</sub>	F <sub>UL, high</sub>	F <sub>DL, low</sub>	F <sub>DL, high</sub>	
V2X_3-47	3	Uu	1710 MHz	1785 MHz	1805 MHz	1880 MHz	FDD
	47	PC5	5855 MHz	5925 MHz	5855 MHz	5925 MHz	HD
V2X_5-47	5	Uu	824 MHz	849 MHz	869 MHz	894 MHz	FDD
	47	PC5	5855 MHz	5925 MHz	5855 MHz	5925 MHz	HD
V2X_7-47	7	Uu	2500 MHz	2570 MHz	2620 MHz	2690 MHz	FDD
	47	PC5	5855 MHz	5925 MHz	5855 MHz	5925 MHz	HD
V2X_8-47	8	Uu	880 MHz	915 MHz	925 MHz	960 MHz	FDD
	47	PC5	5855 MHz	5925 MHz	5855 MHz	5925 MHz	HD
V2X_20-47	20	Uu	832 MHz	862 MHz	791 MHz	821 MHz	FDD
	47	PC5	5855 MHz	5925 MHz	5855 MHz	5925 MHz	HD
V2X_28-47	28	Uu	703 MHz	748 MHz	758 MHz	803 MHz	FDD
	47	PC5	5855 MHz	5925 MHz	5855 MHz	5925 MHz	HD
V2X_34-47	34	Uu	2010 MHz	2025 MHz	2010 MHz	2025 MHz	TDD
	47	PC5	5855 MHz	5925 MHz	5855 MHz	5925 MHz	HD
V2X_39-47	39	Uu	1880 MHz	1920 MHz	1880 MHz	1920 MHz	TDD
	47	PC5	5855 MHz	5925 MHz	5855 MHz	5925 MHz	HD
V2X_41-47	41	Uu	2496 MHz	2690 MHz	2496 MHz	2690 MHz	TDD
	47	PC5	5855 MHz	5925 MHz	5855 MHz	5925 MHz	HD
V2X_71-47	71	Uu	663 MHz	698 MHz	617 MHz	652 MHz	FDD
	47	PC5	5855 MHz	5925 MHz	5855 MHz	5925 MHz	HD

E-UTRA V2X communication is also designed to operate for intra-band multi-carrier operation in the operating bands defined in Table 5.5G-3.

Table 5.5G-3: V2X intra-band multi-carrier operation

V2X multi-carrier Band configuration	V2X operating Band	Interface
V2X_47	47	PC5

## 5.6 Channel bandwidth

Requirements in present document are specified for the channel bandwidths listed in Table 5.6-1.

Table 5.6-1: Transmission bandwidth configuration  $N_{RB}$  in E-UTRA channel bandwidths

Channel bandwidth $BW_{Channel}$ [MHz]	1.4	3	5	10	15	20
Transmission bandwidth configuration $N_{RB}$	6	15	25	50	75	100

Figure 5.6-1 shows the relation between the Channel bandwidth ( $BW_{Channel}$ ) and the Transmission bandwidth configuration ( $N_{RB}$ ). The channel edges are defined as the lowest and highest frequencies of the carrier separated by the channel bandwidth, i.e. at  $F_C \pm BW_{Channel}/2$ .

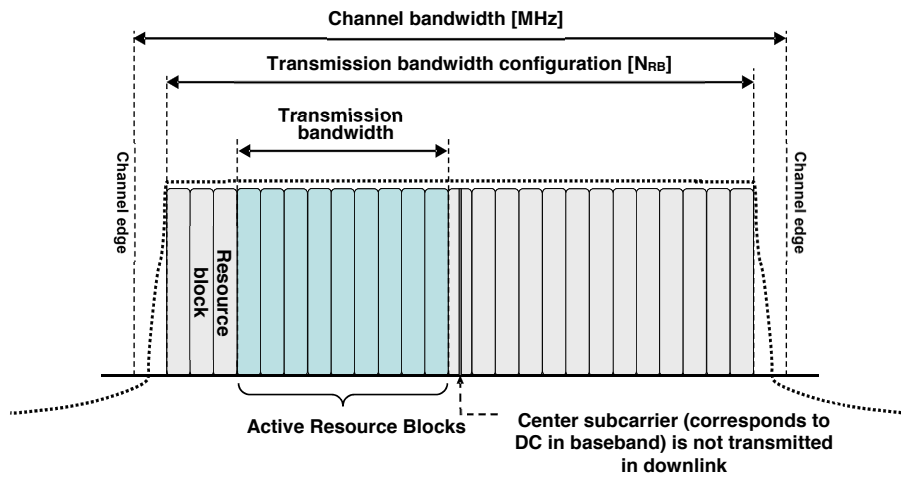

Figure 5.6-1: Definition of channel bandwidth and transmission bandwidth configuration for one E-UTRA carrier

### 5.6.1 Channel bandwidths per operating band

a) The requirements in this specification apply to the combination of channel bandwidths and operating bands shown in Table 5.6.1-1. The transmission bandwidth configuration in Table 5.6.1-1 shall be supported for each of the specified channel bandwidths. The same (symmetrical) channel bandwidth is specified for both the TX and RX path.



**Table 5.6.1-1: E-UTRA channel bandwidth**

E-UTRA band / Channel bandwidth						
E-UTRA Band	1.4 MHz	3 MHz	5 MHz	10 MHz	15 MHz	20 MHz
1			Yes	Yes	Yes	Yes
2	Yes	Yes	Yes	Yes	Yes <sup>1</sup>	Yes <sup>1</sup>
3	Yes	Yes	Yes	Yes	Yes <sup>1</sup>	Yes <sup>1</sup>
4	Yes	Yes	Yes	Yes	Yes	Yes
5	Yes	Yes	Yes	Yes <sup>1</sup>		
6			Yes	Yes <sup>1</sup>		
7			Yes	Yes	Yes <sup>3</sup>	Yes <sup>1,3</sup>
8	Yes	Yes	Yes	Yes <sup>1</sup>		
9			Yes	Yes	Yes <sup>1</sup>	Yes <sup>1</sup>
10			Yes	Yes	Yes	Yes
11			Yes	Yes <sup>1</sup>		
12	Yes	Yes	Yes <sup>1</sup>	Yes <sup>1</sup>		
13			Yes <sup>1</sup>	Yes <sup>1</sup>		
14			Yes <sup>1</sup>	Yes <sup>1</sup>		
...						
17			Yes <sup>1</sup>	Yes <sup>1</sup>		
18			Yes	Yes <sup>1</sup>	Yes <sup>1</sup>	
19			Yes	Yes <sup>1</sup>	Yes <sup>1</sup>	
20			Yes	Yes <sup>1</sup>	Yes <sup>1</sup>	Yes <sup>1</sup>
21			Yes	Yes <sup>1</sup>	Yes <sup>1</sup>	
22			Yes	Yes	Yes <sup>1</sup>	Yes <sup>1</sup>
23	Yes	Yes	Yes	Yes	Yes <sup>1</sup>	Yes <sup>1</sup>
24			Yes	Yes		
25	Yes	Yes	Yes	Yes	Yes <sup>1</sup>	Yes <sup>1</sup>
26	Yes	Yes	Yes	Yes <sup>1</sup>	Yes <sup>1</sup>	
27	Yes	Yes	Yes	Yes <sup>1</sup>		
28		Yes	Yes	Yes <sup>1</sup>	Yes <sup>1</sup>	Yes <sup>1,2</sup>
30			Yes	Yes <sup>1</sup>		
31	Yes	Yes <sup>1</sup>	Yes <sup>1</sup>			
...						
33			Yes	Yes	Yes	Yes
34			Yes	Yes	Yes	
35	Yes	Yes	Yes	Yes	Yes	Yes
36	Yes	Yes	Yes	Yes	Yes	Yes
37			Yes	Yes	Yes	Yes
38			Yes	Yes	Yes <sup>3</sup>	Yes <sup>3</sup>
39			Yes	Yes	Yes <sup>3</sup>	Yes <sup>3</sup>
40			Yes	Yes	Yes	Yes
41			Yes	Yes	Yes	Yes
42			Yes	Yes	Yes	Yes
43			Yes	Yes	Yes	Yes
44		Yes	Yes	Yes	Yes	Yes
45			Yes	Yes	Yes	Yes
46				Yes		Yes
47				Yes		Yes
48			Yes	Yes	Yes	Yes
49				Yes		Yes
50		Yes	Yes	Yes	Yes	Yes
51		Yes	Yes			
52			Yes	Yes	Yes	Yes
53	Yes	Yes	Yes	Yes		
...						
64	Reserved					
65	Yes	Yes	Yes	Yes	Yes	Yes
66	Yes	Yes	Yes	Yes	Yes	Yes
68			Yes	Yes	Yes <sup>5</sup>	
70			Yes	Yes	Yes	Yes <sup>4</sup>
71			Yes	Yes <sup>1</sup>	Yes <sup>1</sup>	Yes <sup>1,6</sup>
72	Yes	Yes <sup>1</sup>	Yes <sup>1</sup>			
73	Yes	Yes	Yes			
74	Yes	Yes	Yes	Yes <sup>1</sup>	Yes <sup>1</sup>	Yes <sup>1</sup>

85			Yes <sup>1</sup>	Yes <sup>1</sup>		
87	Yes	Yes <sup>1</sup>	Yes <sup>1</sup>			
88	Yes	Yes <sup>1</sup>	Yes <sup>1</sup>			

NOTE 1: <sup>1</sup> refers to the bandwidth for which a relaxation of the specified UE receiver sensitivity requirement (subclause 7.3) is allowed.

NOTE 2: <sup>2</sup> For the 20 MHz bandwidth, the minimum requirements are specified for E-UTRA UL carrier frequencies confined to either 713-723 MHz or 728-738 MHz

NOTE 3: <sup>3</sup> refers to the bandwidth for which the uplink transmission bandwidth can be restricted by the network for some channel assignments in FDD/TDD co-existence scenarios in order to meet unwanted emissions requirements (Clause 6.6.3.2).

NOTE 4: <sup>4</sup> For the 20 MHz bandwidth, the minimum requirements are restricted to E-UTRA operation when carrier aggregation is configured.

NOTE 5: <sup>5</sup> For the 15 MHz bandwidth, the minimum requirements are specified for E-UTRA UL carrier frequencies confined to either 705.5 MHz or 710.5-720.5 MHz

NOTE 6: <sup>6</sup> For the 20MHz bandwidth, the minimum requirements are specified for E-UTRA UL carrier frequencies confined to either 673-678 MHz or 683-688MHz.

b) The use of different (asymmetrical) channel bandwidth for the TX and RX is not precluded and is intended to form part of a later release.

### 5.6A Channel bandwidth for CA

For intra-band contiguous carrier aggregation *Aggregated Channel Bandwidth*, *Aggregated Transmission Bandwidth Configuration* and *Guard Bands* are defined as follows, see Figure 5.6A-1.

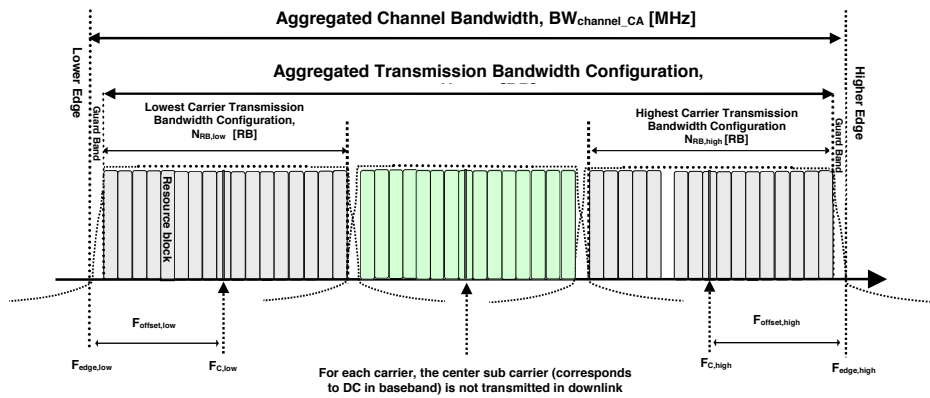

Figure 5.6A-1. Definition of Aggregated channel bandwidth and aggregated channel bandwidth edges

The *aggregated channel bandwidth*,  $BW_{Channel\_CA}$ , is defined as

$$BW_{Channel\_CA} = F_{edge,high} - F_{edge,low} \text{ [MHz].}$$

The lower bandwidth edge  $F_{edge,low}$  and the upper bandwidth edge  $F_{edge,high}$  of the aggregated channel bandwidth are used as frequency reference points for transmitter and receiver requirements and are defined by

$$F_{edge,low} = F_{C,low} - F_{offset,low}$$

$$F_{edge,high} = F_{C,high} + F_{offset,high}$$

The lower and upper frequency offsets depend on the transmission bandwidth configurations of the lowest and highest assigned edge component carrier and are defined as

$$F_{\text{offset,low}} = (0.18N_{\text{RB,low}} + \Delta f_1)/2 + BW_{\text{GB}} \text{ [MHz]}$$

$$F_{\text{offset,high}} = (0.18N_{\text{RB,high}} + \Delta f_1)/2 + BW_{\text{GB}} \text{ [MHz]}$$

where  $\Delta f_1 = \Delta f$  for the downlink with  $\Delta f$  the subcarrier spacing and  $\Delta f_1 = 0$  for the uplink, while  $N_{\text{RB,low}}$  and  $N_{\text{RB,high}}$  are the transmission bandwidth configurations according to Table 5.6-1 for the lowest and highest assigned component carrier, respectively.  $BW_{\text{GB}}$  denotes the *Nominal Guard Band* and is defined in Table 5.6A-1, and the factor 0.18 is the PRB bandwidth in MHz.

NOTE: The values of  $BW_{\text{Channel,CA}}$  for UE and BS are the same if the lowest and the highest component carriers are identical.

Aggregated Transmission Bandwidth Configuration is the number of the aggregated RBs within the fully allocated Aggregated Channel bandwidth and is defined per CA Bandwidth Class (Table 5.6A-1).

For intra-band non-contiguous carrier aggregation *Sub-block Bandwidth* and *Sub-block edges* are defined as follows, see Figure 5.6A-2.

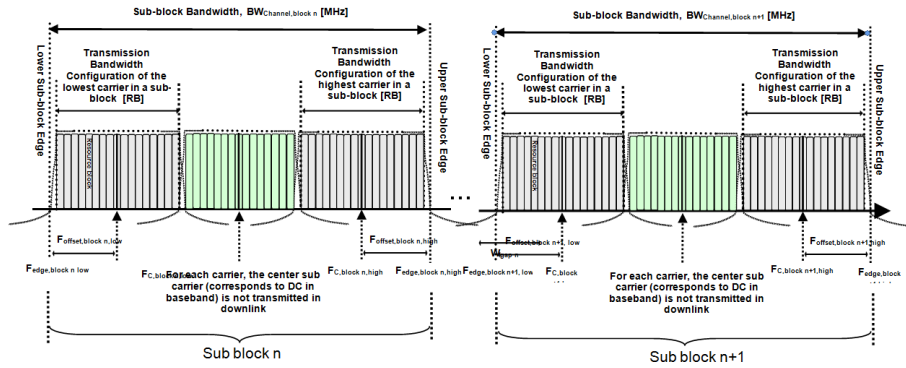

Figure 5.6A-2. Non-contiguous intraband CA terms and definitions

The lower sub-block edge of the Sub-block Bandwidth ( $BW_{\text{Channel,block}}$ ) is defined as

$$F_{\text{edge,block,low}} = F_{\text{C,block,low}} - F_{\text{offset,block,low}}$$

The upper sub-block edge of the Sub-block Bandwidth is defined as

$$F_{\text{edge,block,high}} = F_{\text{C,block,high}} + F_{\text{offset,block,high}}$$

The Sub-block Bandwidth,  $BW_{\text{Channel,block}}$ , is defined as follows:

$$BW_{\text{Channel,block}} = F_{\text{edge,block,high}} - F_{\text{edge,block,low}} \text{ [MHz]}$$

The lower and upper frequency offsets  $F_{\text{offset,block,low}}$  and  $F_{\text{offset,block,high}}$  depend on the transmission bandwidth configurations of the lowest and highest assigned edge component carriers within a sub-block and are defined as

$$F_{\text{offset,block,low}} = (0.18N_{\text{RB,low}} + \Delta f_1)/2 + BW_{\text{GB}} \text{ [MHz]}$$

$$F_{\text{offset,block,high}} = (0.18N_{\text{RB,high}} + \Delta f_1)/2 + BW_{\text{GB}} \text{ [MHz]}$$

where  $\Delta f_1 = \Delta f$  for the downlink with  $\Delta f$  the subcarrier spacing and  $\Delta f_1 = 0$  for the uplink, while  $N_{\text{RB,low}}$  and  $N_{\text{RB,high}}$  are the transmission bandwidth configurations according to Table 5.6-1 for the lowest and highest assigned component carrier within a sub-block, respectively.  $BW_{\text{GB}}$  denotes the *Nominal Guard Band* and is defined in Table 5.6A-1, and the factor 0.18 is the PRB bandwidth in MHz.

The sub-block gap size between two consecutive sub-blocks  $W_{\text{gap}}$  is defined as

$$W_{\text{gap}} = F_{\text{edge,block } n+1, \text{low}} - F_{\text{edge,block } n, \text{high}} \text{ [MHz]}$$

**Table 5.6A-1: CA bandwidth classes and corresponding nominal guard bands**

CA Bandwidth Class	Aggregated Transmission Bandwidth Configuration	Number of contiguous CC	Nominal Guard Band $BW_{\text{GB}}$
A	$N_{\text{RB,agg}} \leq 100$	1	$a_1 BW_{\text{Channel}(1)} - 0.5\Delta f_1$ (NOTE 2)
B	$25 < N_{\text{RB,agg}} \leq 100$	2	$0.05 \max(BW_{\text{Channel}(1)}, BW_{\text{Channel}(2)}) - 0.5\Delta f_1$
C	$100 < N_{\text{RB,agg}} \leq 200$	2	$0.05 \max(BW_{\text{Channel}(1)}, BW_{\text{Channel}(2)}) - 0.5\Delta f_1$
D	$200 < N_{\text{RB,agg}} \leq 300$	3	$0.05 \max(BW_{\text{Channel}(1)}, BW_{\text{Channel}(2)}, BW_{\text{Channel}(3)}) - 0.5\Delta f_1$
E	$300 < N_{\text{RB,agg}} \leq 400$	4	$0.05 \max(BW_{\text{Channel}(1)}, BW_{\text{Channel}(2)}, BW_{\text{Channel}(3)}, BW_{\text{Channel}(4)}) - 0.5\Delta f_1$
F	$400 < N_{\text{RB,agg}} \leq 500$	5	$0.05 \max(BW_{\text{Channel}(1)}, BW_{\text{Channel}(2)}, BW_{\text{Channel}(3)}, BW_{\text{Channel}(4)}, BW_{\text{Channel}(5)}) - 0.5\Delta f_1$
I	$700 < N_{\text{RB,agg}} \leq 800$	8	NOTE 3

NOTE 1:  $BW_{\text{Channel}(j)}$ ,  $j = 1, 2, 3, 4$  is the channel bandwidth of an E-UTRA component carrier according to Table 5.6-1 and  $\Delta f_1 = \Delta f$  for the downlink with  $\Delta f$  the subcarrier spacing while  $\Delta f_1 = 0$  for the uplink.  
NOTE 2:  $a_1 = 0.16/1.4$  for  $BW_{\text{Channel}(1)} = 1.4$  MHz whereas  $a_1 = 0.05$  for all other channel bandwidths.  
NOTE 3: Applicable for later releases.

The channel spacing between centre frequencies of contiguously aggregated component carriers is defined in subclause 5.7.1A.

### 5.6A.1 Channel bandwidths per operating band for CA

The requirements for carrier aggregation in this specification are defined for carrier aggregation configurations with associated bandwidth combination sets. For inter-band carrier aggregation, a *carrier aggregation configuration* is a combination of operating bands, each supporting a carrier aggregation bandwidth class. For intra-band contiguous carrier aggregation, a carrier aggregation configuration is a single operating band supporting a carrier aggregation bandwidth class.

For each carrier aggregation configuration, requirements are specified for all bandwidth combinations contained in a *bandwidth combination set*, which is indicated per supported band combination in the UE radio access capability. A UE can indicate support of several bandwidth combination sets per band combination.

Requirements for intra-band contiguous carrier aggregation are defined for the carrier aggregation configurations and bandwidth combination sets specified in Table 5.6A.1-1. Requirements for inter-band carrier aggregation are defined for the carrier aggregation configurations and bandwidth combination sets specified in Table 5.6A.1-2, Table 5.6A.1-2a, Table 5.6A.1-2b and Table 5.6A.1-2c. Requirements for intra-band non-contiguous carrier aggregation are defined for the carrier aggregation configurations and bandwidth combination sets specified in Table 5.6A.1-3.

The DL component carrier combinations for a given CA configuration shall be symmetrical in relation to channel centre unless stated otherwise in Table 5.6A.1-1, Table 5.6A.1-2, Table 5.6A.1-2a, Table 5.6A.1-2b and Table 5.6A.1-2c.

**Table 5.6A.1-1: E-UTRA CA configurations and bandwidth combination sets defined for intra-band contiguous CA**

E-UTRA CA configuration	Uplink CA configurations (NOTE 3)	E-UTRA CA configuration / Bandwidth combination set						
		Component carriers in order of increasing carrier frequency					Maximum aggregated bandwidth [MHz]	Bandwidth combination set
		Channel bandwidths for carrier [MHz]	Channel bandwidths for carrier [MHz]	Channel bandwidths for carrier [MHz]	Channel bandwidths for carrier [MHz]	Channel bandwidths for carrier [MHz]		
CA_1C	CA_1C	15	15				40	0
		20	20					
		5, 10, 15	20				40	1
CA_2C		5	20				40	0
		10	15, 20					
		15	10, 15, 20					
CA_3B		5	3				10	0
		3, 5	5					
		5, 10, 15	20					
CA_3C	CA_3C	20	5, 10, 15, 20				40	0
		5, 10	10					
CA_5B	CA_5B	10	5				20	0
		3	5					
		5	3				8	1
CA_7B		15	5				20	0
CA_7C	CA_7C	15	15				40	0
		20	20					
		10	20					
		15	15, 20				40	1
		20	10, 15, 20					
		15	10, 15				40	2
CA_8B	CA_8B	5,10	10				20	0
		10	5					
CA_12B	-	5	5, 10				15	0
CA_23B	-	10	10				20	0
		5	15					
CA_27B	-	1.4, 3, 5	5				13	0
		1.4, 3	10					
CA_28C	-	5	20				30	0
		10	15, 20					
		15	10, 15					
		20	5, 10					
CA_38C	CA_38C	15	15				40	0
		20	20					
CA_39C	CA_39C	5,10,15	20				35	0
		20	5, 10, 15					
CA_40C	CA_40C	10	20				40	0
		15	15					

		20	10, 20					
		10, 15	20				40	1
		15	15					
		20	10, 15, 20					
CA_40D	CA_40C, CA_40D	10, 15, 20	20	20			60	0
		20	10, 15	20				
		20	20	10, 15				
		15, 20	15, 20	15, 20			60	1
CA_40E	-	15, 20	15, 20	15, 20	20		80	0
CA_40F	-	15, 20	15, 20	15, 20	20	20	100	0
		10	20				40	0
		15	15, 20					
		20	10, 15, 20					
		5, 10	20				40	1
		15	15, 20					
		20	5, 10, 15, 20					
CA_41C <sup>5</sup>	CA_41C	10	15, 20				40	2
		15	10, 15, 20					
		20	10, 15, 20					
		10	20				40	3
		20	20					
		10	20	15			60	0
		10	15, 20	20				
		15	20	10, 15				
		15	10, 15, 20	20				
		20	15, 20	10				
		20	10, 15, 20	15, 20				
CA_41D	CA_41C, CA_41D							
CA_41E	CA_41C, CA_41D	15, 20	15, 20	15, 20	20		80	0
CA_41F	CA_41C, CA_41D	10, 15, 20	15, 20	20	20	20	100	0
		5, 10, 15, 20	20				40	0
		20	5, 10, 15					
CA_42C <sup>5</sup>	CA_42C	10, 15, 20	20				40	1
		20	10, 15					
		5, 10, 15, 20	20	20			60	0
		20	20	5, 10, 15				
CA_42D	CA_42C	10, 15, 20	20	20			60	1
		20	20	10, 15				



CA_42E	CA_42C	5,10,15,20	20	20	20		80	0
		20	20	20	5,10,15			
CA_42F	CA_42C	5, 10, 15, 20	20	20	20	20	100	0
		20	20	20	20	5, 10, 15, 20		
CA_43C	-	5	20				40	0
		10	15, 20					
		15	10, 15, 20					
		20	5, 10, 15, 20					
CA_46C <sup>4</sup>	-	20	20				40	0
		20	10, 20				40	1
		10, 20	20					
CA_46D <sup>4</sup>	-	20	20	20			60	0
		20	20	10, 20			60	1
		10, 20	20	20				
CA_46E <sup>4</sup>	-	20	20	20	20		80	0
		20	20	20	10, 20		80	1
		10	20	20	20			
CA_48B	CA_48B	10	10				20	0
CA_48C	CA_48C	5, 10, 15, 20	20				40	0
		20	5, 10, 15					
CA_48D	CA_48C	5,10,15,20	20	20			60	0
		20	20	5,10,15				
CA_48E	CA_48C	5,10,15,20	20	20	20		80	0
		20	20	20	5,10,15			
CA_48F	-	5, 10, 15, 20	20	20	20	20	100	0
		20	20	20	20	5, 10, 15, 20		
CA_66B	CA_66B	5	5, 10, 15				20	0
		10	5, 10					
		15	5					
CA_66C	CA_66C	5	20				40	0
		10	15, 20					
		15	10, 15, 20					
		20	5, 10, 15, 20					
CA_66D	-	5	20	20			60	0
		20	5	20				
		20	20	5				
		10	20	15				
		15	20	10				
		10, 15, 20	15, 20	20				
		15, 20	10	20				
		15	15, 20	15				
		20	15, 20	10, 15				
20	10	15						
CA_70C	-	5	20				25	0
		10	15					
		15	10					

- 
- IOTE 1: The CA configuration refers to an operating band and a CA bandwidth class specified in Table 5.6A-1 (the indexing letter). Absence of a CA bandwidth class for an operating band implies support of all classes.
- IOTE 2: For the supported CC bandwidth combinations, the CC downlink and uplink bandwidths are equal.
- IOTE 3: Uplink CA configurations are the configurations supported by the present release of specifications.
- IOTE 4: Restricted to E-UTRA operation when inter-band carrier aggregation is configured. The downlink operating band is paired with the uplink operating band (external) of the carrier aggregation configuration that is supporting the configured Pcell.
- IOTE 5: 8Rx Requirements are applicable for this band configuration if UE supports 8Rx.
-

**Table 5.6A.1-2: E-UTRA CA configurations and bandwidth combination sets defined for inter-band CA (two bands)**

E-UTRA CA configuration / Bandwidth combination set											
E-UTRA CA Configuration	Uplink CA configurations (NOTE 4)	E-UTRA Bands	1.4 MHz	3 MHz	5 MHz	10 MHz	15 MHz	20 MHz	Maximum aggregated bandwidth [MHz]	Bandwidth combination set	
CA_1A-3A	CA_1A-3A	1			Yes	Yes	Yes	Yes	40	0	
		3			Yes	Yes	Yes	Yes			
		1			Yes	Yes	Yes	Yes	40	1	
		3		Yes	Yes	Yes	Yes	Yes			
CA_1A-1A-3A	-	1	See CA_1A-1A Bandwidth combination set 0 in Table 5.6A.1-3						60	0	
		3			Yes	Yes	Yes	Yes			
CA_1A-1A-7A	CA_1A-7A	1	See CA_1A-1A Bandwidth combination set 0 in Table 5.6A.1-3						60	0	
		7			Yes	Yes	Yes	Yes			
CA_1A-1A-7C	CA_7C	1	See CA_1A-1A Bandwidth Combination Set 0 in Table 5.6A.1-3						80	0	
		7	See CA_7C in Table 5.6A.1-1 of 36.101 Bandwidth combination set 2								
CA_1A-3A-3A	CA_1A-3A	1			Yes	Yes	Yes	Yes	60	0	
		3	See CA_3A-3A Bandwidth Combination Set 0 in Table 5.6A.1-3								
CA_1A-1A-3A-3A	-	1	See CA_1A-1A Bandwidth Combination Set 0 in Table 5.6A.1-3						80	0	
		3	See CA_3A-3A Bandwidth Combination Set 0 in Table 5.6A.1-3								
CA_1A-3C	CA_1A-3A, CA_3C	1			Yes	Yes	Yes	Yes	60	0	
		3	See CA_3C Bandwidth Combination Set 0 in Table 5.6A.1-1								
CA_1A-1A-3C	CA_3C	1	See CA_1A-1A Bandwidth Combination Set 0 in the Table 5.6A.1-3						80	0	
		3	See CA_3C Bandwidth combination set 0 in Table 5.6A.1-1								
CA_1A-5A	CA_1A-5A	1				Yes			20	0	
		5				Yes					
		1			Yes	Yes	Yes	Yes	30	1	
		5			Yes	Yes					
CA_1A-1A-5A	-	1	See CA_1A-1A Bandwidth combination set 0 in Table 5.6A.1-3						50	0	
		5			Yes	Yes					
CA_1C-5A	-	1	See CA_1C Bandwidth Combination Set 1 in Table 5.6A.1-1						50	0	
		5			Yes	Yes					
CA_1A-7A	CA_1A-7A	1			Yes	Yes	Yes	Yes	40	0	
		7				Yes	Yes	Yes			
		1			Yes	Yes	Yes	Yes	40	1	
		7			Yes	Yes	Yes	Yes			
CA_1A-7A-7A	CA_1A-7A	1			Yes	Yes	Yes	Yes	60	0	
		7	See CA_7A-7A Bandwidth Combination Set 3 in Table 5.6A.1-3								
	CA_1A-7A	CA_1A-7A	1			Yes	Yes	Yes	Yes	60	1
			7	See CA_7A-7A Bandwidth Combination Set 1 in Table 5.6A.1-3							
CA_1A-7C	CA_1A-7A, CA_7C	1			Yes	Yes	Yes	Yes	60	0	
		7	See CA_7C Bandwidth Combination Set 2 in Table 5.6A.1-1								
	CA_1A-7A, CA_7C	CA_1A-7A, CA_7C	1			Yes	Yes	Yes	Yes	60	1
			7	See CA_7C Bandwidth Combination Set 1 in Table 5.6A.1-1							
CA_1A-8A	CA_1A-8A	1			Yes	Yes	Yes	Yes	30	0	
		8			Yes	Yes					
		1			Yes	Yes			20	1	
		8			Yes	Yes					
		1			Yes	Yes	Yes	Yes	30	2	

		8		Yes	Yes	Yes				
CA_1A-11A	CA_1A-11A	1			Yes	Yes	Yes	Yes	30	0
		11			Yes	Yes				
CA_1A-18A	CA_1A-18A	1			Yes	Yes	Yes	Yes	35	0
		18			Yes	Yes	Yes			
		1			Yes	Yes			20	1
18			Yes	Yes						
CA_1A-19A	CA_1A-19A	1			Yes	Yes	Yes	Yes	35	0
		19			Yes	Yes	Yes			
CA_1A-20A	CA_1A-20A	1			Yes	Yes	Yes	Yes	40	0
		20			Yes	Yes	Yes	Yes		
CA_1A-21A	CA_1A-21A	1			Yes	Yes	Yes	Yes	35	0
		21			Yes	Yes	Yes	Yes		
CA_1A-26A	CA_1A-26A	1			Yes	Yes	Yes	Yes	35	0
		26			Yes	Yes	Yes			
		1			Yes	Yes			20	1
26			Yes	Yes						
CA_1A-28A	CA_1A-28A	1			Yes	Yes	Yes	Yes	40	0
		28			Yes	Yes	Yes	Yes		
		1			Yes	Yes			20	1
28			Yes	Yes						
CA_1A-1A-28A	-	1	See CA_1A-1A Bandwidth combination set 0 in Table 5.6A.1-3						60	0
		28			Yes	Yes	Yes	Yes		
CA_1A-32A	-	1			Yes	Yes	Yes	Yes	40	0
		32			Yes	Yes	Yes	Yes		
CA_1A-38A	-	1			Yes	Yes	Yes	Yes	40	0
		38			Yes	Yes	Yes	Yes		
CA_1A-40A	-	1			Yes	Yes	Yes	Yes	40	0
		40			Yes	Yes	Yes	Yes		
CA_1A-40C	-	1			Yes	Yes	Yes	Yes	60	0
		40	See CA_40C Bandwidth Combination Set 1 in Table 5.6A.1-1							
CA_1A-41A	CA_1A-41A	1			Yes	Yes	Yes	Yes	40	1
		41			Yes	Yes	Yes	Yes		
CA_1A-41A <sup>8</sup>	-	1			Yes	Yes	Yes	Yes	40	0
		41			Yes	Yes	Yes	Yes		
CA_1A-41C <sup>8</sup>	CA_1A-41A CA_1A-41C	1			Yes	Yes	Yes	Yes	60	0
		41	See CA_41C Bandwidth Combination Set 1 in Table 5.6A.1-1							
CA_1A-41D <sup>8</sup>	-	1			Yes	Yes	Yes	Yes	80	0
		41	See CA_41D Bandwidth combination set 0 at Table 5.6A.1-1							
CA_1A-42A	CA_1A-42A	1			Yes	Yes	Yes	Yes	40	0
		42			Yes	Yes	Yes	Yes		
CA_1A-42A-42A	CA_1A-42A	1			Yes	Yes	Yes	Yes	60	0
		42	See CA_42A-42A Bandwidth Combination Set 0 in Table 5.6A.1-3							
CA_1A-42C	CA_1A-42A, CA_1A-42C, CA_42C	1			Yes	Yes	Yes	Yes	60	0
		42	See CA_42C Bandwidth Combination Set 0 in Table 5.6A.1-1							
CA_1A-42A-42C	CA_1A-42A	1			Yes	Yes	Yes	Yes	80	0
		42	See CA_42A-42C Bandwidth Combination Set 0 in Table 5.6A.1-3							
CA_1A-42C-42C	CA_1A-42A	1			Yes	Yes	Yes	Yes	100	0
		42	See CA_42C-42C Bandwidth Combination Set 0 in Table 5.6A.1-3							
CA_1A-42D	CA_1A-42A	1			Yes	Yes	Yes	Yes	80	0
		42	See CA_42D Bandwidth Combination Set 0 in Table 5.6A.1-1							
CA_1A-42E	CA_1A-42A	1			Yes	Yes	Yes	Yes	100	0
		42	See CA_42E Bandwidth Combination Set 0 in Table 5.6A.1-1							

CA_1A-43A	-	1			Yes	Yes	Yes		35	0
		43			Yes	Yes	Yes	Yes		
CA_1A-46A	-	1			Yes	Yes	Yes	Yes	40	0
		46						Yes		
		1			Yes	Yes	Yes	Yes	40	1
		46				Yes		Yes		
CA_1A-46C	-	1			Yes	Yes	Yes	Yes	60	0
		46	See CA_46C Bandwidth Combination Set 0 in Table 5.6A.1-1							
	-	1			Yes	Yes	Yes	Yes	60	1
		46	See CA_46C Bandwidth Combination Set 1 in Table 5.6A.1-1							
CA_1A-46D	-	1			Yes	Yes	Yes	Yes	80	0
		46	See CA_46D Bandwidth combination set 0 in Table 5.6A.1-1							
		1			Yes	Yes	Yes	Yes	80	1
		46	See CA_46D Bandwidth combination set 1 in Table 5.6A.1-1							
CA_1A-46E	-	1			Yes	Yes	Yes	Yes	100	0
		46	See CA_46E Bandwidth Combination Set 0 in Table 5.6A.1-1							
		1			Yes	Yes	Yes	Yes	100	1
		46	See CA_46E Bandwidth Combination Set 1 in Table 5.6A.1-1							
CA_1C-3A	-	1	See CA_1C Bandwidth combination set 1 in Table 5.6A.1-1						60	0
CA_2A-4A	CA_2A-4A	2	Yes	Yes	Yes	Yes	Yes	Yes	40	0
		4			Yes	Yes	Yes	Yes		
		2			Yes	Yes			20	1
		4			Yes	Yes				
		2			Yes	Yes	Yes	Yes	40	2
		4			Yes	Yes	Yes	Yes		
CA_2A-2A-4A	-	2	See CA_2A-2A Bandwidth Combination Set 0 in Table 5.6A.1-3						60	0
4			Yes	Yes	Yes	Yes				
CA_2A-4A-4A	-	2	See CA_2A-4A Bandwidth Combination Set 0 in Table 5.6A.1-3						60	0
4	See CA_4A-4A Bandwidth Combination Set 0 in Table 5.6A.1-3									
CA_2A-5A	CA_2A-5A	2			Yes	Yes	Yes	Yes	30	0
		5			Yes	Yes				
		2			Yes	Yes			20	1
		5			Yes	Yes				
CA_2A-2A-5A	-	2	See CA_2A-2A Bandwidth Combination Set 0 in Table 5.6A.1-3						50	0
5			Yes	Yes						
CA_2A-2A-46D	-	2	See CA_2A-2A Bandwidth Combination Set 0 in Table 5.6A.1-3						100	0
		46	See CA_46D Bandwidth Combination Set 0 in Table 5.6A.1-1							
CA_2C-5A	-	2	See CA_2C Bandwidth combination set 0 in Table 5.6A.1-1						50	0
CA_2A-5B	CA_2A-5A	5			Yes	Yes			40	0
		2	See CA_5B Bandwidth Combination Set 0 in Table 5.6A.1-1							
CA_2A-2A-5B	-	2	See CA_2A-2A Bandwidth combination set 0 in Table 5.6A.1-3						60	0
		5	See CA_5B Bandwidth Combination Set 0 in Table 5.6A.1-1							

CA_2C-5B	-	2	See CA_2C Bandwidth combination set 0 in Table 5.6A.1-1				60	0	
		5	See CA_5B Bandwidth Combination Set 0 in Table 5.6A.1-1						
CA_2A-2A-7A	-	2	See CA_2A-2A Bandwidth Combination Set 0 in Table 5.6A.1-3				60	0	
		7		Yes	Yes	Yes			Yes
CA_2A-7A	CA_2A-7A	2		Yes	Yes	Yes	Yes	40	0
		7		Yes	Yes	Yes	Yes		
CA_2A-7A-7A	-	2		Yes	Yes	Yes	Yes	60	0
		7	See the CA_7A-7A Bandwidth combination set 1 in Table 5.6A.1-3						
CA_2A-7C	-	2		Yes	Yes	Yes	Yes	60	0
		7	See the CA_7C Bandwidth combination set 1 in Table 5.6A.1-1						
CA_2A-12A	CA_2A-12A	2		Yes	Yes	Yes	Yes	30	0
		12		Yes	Yes				
		2		Yes	Yes	Yes	Yes	30	1
		12	Yes	Yes	Yes				
		2		Yes	Yes			20	2
12		Yes	Yes						
CA_2A-2A-12A	-	2	See CA_2A-2A Bandwidth Combination Set 0 in Table 5.6A.1-3				50	0	
		12		Yes	Yes				
CA_2A-12A-12A	-	2		Yes	Yes	Yes	Yes	30	0
		12	See CA_12A-12A Bandwidth Combination Set 0 in Table 5.6A.1-3						
CA_2A-2A-12A-12A	-	2	See CA_2A-2A Bandwidth Combination Set 0 in Table 5.6A.1-3				50	0	
		12	See CA_12A-12A Bandwidth Combination Set 0 in Table 5.6A.1-3						
CA_2A-12B	CA_2A-12A	2		Yes	Yes	Yes	Yes	35	0
		12	See CA_12B Bandwidth Combination Set 0 in Table 5.6A.1-1						
CA_2A-2A-12B	-	2	See CA_2A-2A Bandwidth combination set 0 in Table 5.6A.1-3				55	0	
		12	See CA_12B Bandwidth Combination Set 0 in Table 5.6A.1-1						
CA_2C-12A	-	2	See CA_2C Bandwidth combination set 0 in Table 5.6A.1-1				50	0	
		12		Yes	Yes				
CA_2A-13A	CA_2A-13A	2		Yes	Yes	Yes	Yes	30	0
		13		Yes	Yes				
		2		Yes	Yes			20	1
		13		Yes	Yes				
		2		Yes	Yes	Yes	Yes	30	2
13		Yes	Yes						
CA_2A-2A-13A	CA_2A-13A	2	See CA_2A-2A Bandwidth Combination Set 0 in Table 5.6A.1-3				50	0	
		13		Yes	Yes				
CA_2A-14A	CA_2A-14A	2		Yes	Yes	Yes	Yes	30	0
		14		Yes	Yes				
CA_2A-2A-14A	-	2	See CA_2A-2A Bandwidth Combination Set 0 in Table 5.6A.1-3				50	0	
		14		Yes	Yes				
CA_2A-17A	-	2		Yes	Yes			20	0
		17		Yes	Yes				
CA_2A-26A	-	2		Yes	Yes	Yes	Yes	35	0
		26		Yes	Yes	Yes	Yes		
CA_2A-28A	-	2		Yes	Yes	Yes	Yes	40	0
		28		Yes	Yes	Yes	Yes		
CA_2A-29A	-	2		Yes	Yes			20	0
		29	Yes	Yes	Yes				

		2		Yes	Yes			20	1
		29		Yes	Yes				
		2		Yes	Yes	Yes	Yes	30	2
		29		Yes	Yes				
CA_2A-2A-29A	-	2	See CA_2A-2A Bandwidth Combination Set 0 in Table 5.6A.1-3					50	0
		29		Yes	Yes				
CA_2C-29A	-	2	See CA_2C Bandwidth Combination Set 0 in table 5.6A.1-1					50	0
		29		Yes	Yes				
CA_2A-30A	CA_2A-30A	2		Yes	Yes	Yes	Yes	30	0
		30		Yes	Yes				
CA_2A-2A-30A	-	2	See CA_2A-2A Bandwidth Combination Set 0 in table 5.6A.1-3					50	0
		30		Yes	Yes				
CA_2C-30A	-	2	See CA_2C Bandwidth combination set 0 in Table 5.6A.1-1					50	0
		30		Yes	Yes				
CA_2A-46A	CA_2A-46A	2		Yes	Yes	Yes	Yes	40	0
		46					Yes		
CA_2A-2A-46A	-	2	See CA_2A-2A Bandwidth Combination Set 0 in table 5.6A.1-3					60	0
		46					Yes		
CA_2A-46A-46C	-	2	See CA_46A-46C Bandwidth Combination Set 0 in Table 5.6A.1-3					80	0
		46							
CA_2A-46C	-	2		Yes	Yes	Yes	Yes	60	0
		46	See CA_46C Bandwidth Combination Set 0 in Table 5.6A.1-1						
CA_2A-2A-46C	-	2	See CA_2A-2A Bandwidth Combination Set 0 in Table 5.6A.1-3					80	0
		46	See CA_46C Bandwidth Combination Set 0 in Table 5.6A.1-1						
CA_2A-46D	-	2		Yes	Yes	Yes	Yes	80	0
		46	See CA_46D Bandwidth Combination Set 0 in Table 5.6A.1-1						
CA_2A-46E	-	2		Yes	Yes	Yes	Yes	100	0
		46	See CA_46E Bandwidth combination set 0 in the Table 5.6A.1-1						
CA_2A-46A-46A	-	2		Yes	Yes	Yes	Yes	60	0
		46	See CA_46A-46A Bandwidth combination set 0 in Table 5.6A.1-3						
CA_2A-46A-46D	-	2		Yes	Yes	Yes	Yes	100	0
		46	See CA_46A-46D Bandwidth Combination Set 0 in Table 5.6A.1-3						
CA_2A-48A	CA_2A-48A	2		Yes	Yes	Yes	Yes	40	0
		48		Yes	Yes	Yes	Yes		
CA_2A-48A-48A	CA_2A-48A	2		Yes	Yes	Yes	Yes	60	0
		48	See CA_48A-48A Bandwidth combination set 0 in the Table 5.6A.1-3						
CA_2A-48C	CA_2A-48A, CA_48C	2		Yes	Yes	Yes	Yes	60	0
		48	See CA_48C Bandwidth combination set 0 in Table 5.6A.1-1						
CA_2A-48A-48C	CA_2A-48A	2		Yes	Yes	Yes	Yes	80	0
		48	See the CA_48A-48C Bandwidth combination set 0 in the Table 5.6A.1-3						
CA_2A-48A-48D	CA_2A-48A	2		Yes	Yes	Yes	Yes	100	0
		48	See CA_48A-48D Bandwidth Combination Set 0 in Table 5.6A.1-3						
CA_2A-48C-48C	CA_2A-48A	2		Yes	Yes	Yes	Yes	100	0
		48	See CA_48C-48C Bandwidth Combination Set 0 in Table 5.6A.1-3						
CA_2A-48D	CA_2A-48A	2		Yes	Yes	Yes	Yes	80	0



		48	See the CA_48D Bandwidth combination set 0 in the Table 5.6A.1-1					
CA_2A-48E	CA_2A-48A	2		Yes	Yes	Yes	Yes	
		48	See CA_48E Bandwidth Combination Set 0 in Table 5.6A.1-1				100	0
CA_2A-49A	CA_2A-49A	2		Yes	Yes	Yes	Yes	
		49			Yes	Yes	Yes	
CA_2A-66A	CA_2A-66A	2	Yes	Yes	Yes	Yes	Yes	
		66		Yes	Yes	Yes	Yes	
		2		Yes	Yes			
		66		Yes	Yes			
		2		Yes	Yes	Yes	Yes	
CA_2A-66B	CA_66B	2		Yes	Yes	Yes	Yes	
		66	See CA_66B Bandwidth Combination Set 0 in Table 5.6A.1-1				40	0
CA_2A-66C	-	2		Yes	Yes	Yes	Yes	
		66	See CA_66C Bandwidth Combination Set 0 in Table 5.6A.1-1				60	0
CA_2A-66D	-	2		Yes	Yes	Yes	Yes	
		66	See CA_66D Bandwidth Combination Set 0 in Table 5.6A.1-1				80	0
CA_2A-2A-66A	-	2	See CA_2A-2A Bandwidth Combination Set 0 in Table 5.6A.1-3				60	0
		66		Yes	Yes	Yes		
CA_2A-2A-66A-66A	-	2	See CA_2A-2A Bandwidth Combination Set 0 in Table 5.6A.1-3				80	0
		66	See CA_66A-66A Bandwidth Combination Set 0 in Table 5.6A.1-3					
CA_2A-2A-66A-66B	-	2	See CA_2A-2A Bandwidth Combination Set 0 in Table 5.6A.1-3				80	0
		66	See CA_66A-66B Bandwidth Combination Set 0 in Table 5.6A.1-3					
CA_2A-2A-66A-66C	-	2	See CA_2A-2A Bandwidth Combination Set 0 in Table 5.6A.1-3				100	0
		66	See CA_66A-66C Bandwidth Combination Set 0 in Table 5.6A.1-3					
CA_2A-66A-66A	-	2		Yes	Yes	Yes	Yes	
		66	See CA_66A-66A Bandwidth Combination Set 0 in Table 5.6A.1-3				60	0
CA_2A-66A-66A-66A	-	2		Yes	Yes	Yes	Yes	
		66	See CA_66A-66A-66A Bandwidth Combination Set 0 in Table 5.6A.1-4				80	0
CA_2A-66A-66B	CA_66B	2		Yes	Yes	Yes	Yes	
		66	See CA_66A-66B Bandwidth combination set 0 in Table 5.6A.1-3				60	0
CA_2A-66A-66C		2		Yes	Yes	Yes	Yes	
		66	See CA_66A-66C Bandwidth combination set 0 in Table 5.6A.1-3				80	0
CA_2A-2A-66B	-	2	See CA_2A-2A Bandwidth Combination Set 0 in Table 5.6A.1-3				60	0
		66	See CA_66B Bandwidth combination set 0 in Table 5.6A.1-1					
CA_2A-2A-66C	-	2	See CA_2A-2A Bandwidth Combination Set 0 in Table 5.6A.1-3				80	0
		66	See CA_66C Bandwidth combination set 0 in Table 5.6A.1-1					
CA_2A-2A-66D		2	See CA_2A-2A Bandwidth Combination Set 0 in Table 5.6A.1-3				100	0
		66	See CA_66D Bandwidth combination set 0 in Table 5.6A.1-1					
CA_2C-66A	-	2	See CA_2C Bandwidth combination set 0 in Table 5.6A.1-1				60	0
		66		Yes	Yes	Yes		

CA_2C-66A-66A		2	See CA_2C Bandwidth combination set 0 in Table 5.6A.1-1				80	0	
		66	See CA_66A-66A Bandwidth Combination Set 0 in Table 5.6A.1-3						
CA_2A-71A	-	2		Yes	Yes	Yes	Yes	40	0
		71		Yes	Yes	Yes	Yes		
		2		Yes	Yes			20	1
		71		Yes	Yes				
CA_2A-2A-71A	-	2	See CA_2A-2A Bandwidth Combination Set 0 in Table 5.6A.1-3				60	0	
		71		Yes	Yes	Yes			Yes
CA_3A-5A	CA_3A-5A	3		Yes	Yes			30	0
		5		Yes	Yes				
		3			Yes			20	1
		5		Yes	Yes				
		3		Yes	Yes	Yes	Yes	30	2
		5		Yes	Yes				
		3		Yes	Yes	Yes	Yes	30	3
		5	Yes	Yes	Yes				
		3	Yes	Yes	Yes				
5	Yes	Yes	Yes			20	4		
CA_3A-3A-5A	-	3	See CA_3A-3A Bandwidth Combination Set 0 in Table 5.6A.1-3				50	0	
		5		Yes	Yes				
CA_3C-5A	-	3	See CA_3C Bandwidth Combination Set 0 in Table 5.6A.1-1				50	0	
		5		Yes	Yes				
CA_3A-7A	CA_3A-7A	3		Yes	Yes	Yes	Yes	40	0
		7			Yes	Yes	Yes		
		3		Yes	Yes	Yes	Yes	40	1
		7		Yes	Yes	Yes	Yes		
CA_3A-3A-7A	CA_3A-7A	3	See CA_3A-3A Bandwidth Combination Set 0 in Table 5.6A.1-3				60	0	
		7		Yes	Yes	Yes			Yes
		3	See CA_3A-3A Bandwidth Combination Set 1 in Table 5.6A.1-3				50	1	
		7		Yes	Yes	Yes			Yes
CA_3A-3A-7A-7A	CA_3A-7A	3	See CA_3A-3A Bandwidth Combination Set 0 in table 5.6A.1-3				80	0	
		7	See CA_7A-7A Bandwidth Combination Set 1 in table 5.6A.1-3						
		3	See CA_3A-3A Bandwidth Combination Set 1 in table 5.6A.1-3				60	1	
		7	See CA_7A-7A Bandwidth Combination Set 2 in table 5.6A.1-3						
CA_3A-3A-7C	7C	3	See CA_3A-3A Bandwidth Combination Set 0 in Table 5.6A.1-3				80	0	
		7	See CA_7C in Table 5.6A.1-1 of 36.101 Bandwidth combination set 2						
CA_3A-3A-42D	CA_3A-42A	3	See CA_3A-3A Bandwidth Combination Set 0 in Table 5.6A.1-3				100	0	
		42	See CA_42D Bandwidth Combination Set 0 in Table 5.6A.1-1:						
CA_3A-7A-7A	CA_3A-7A	3		Yes	Yes	Yes	Yes	60	0
		7	See CA_7A-7A Bandwidth combination set 1 in table 5.6A.1-3						
		3		Yes	Yes	Yes	Yes	50	1
		7	See CA_7A-7A Bandwidth combination set 2 in table 5.6A.1-3						
CA_3A-7B	-	3		Yes	Yes	Yes	Yes	40	0
		7	See CA_7B bandwidth combination set 0 in table 5.6A.1-1						
CA_3A-7C		3		Yes	Yes	Yes	Yes	60	0

	CA_3A-7A CA_7C	7	See CA_7C Bandwidth combination set 1 in table 5.6A.1-1				60	1	
		3	Yes	Yes	Yes	Yes			
		7	See CA_7C Bandwidth combination set 2 in table 5.6A.1-1						
CA_3C-7A	CA_3A-7A CA_3C	3	See CA_3C Bandwidth Combination Set 0 in table 5.6A.1-1				60	0	
		7	Yes	Yes	Yes	Yes			
CA_3C-7C	CA_3A-7A, CA_3C, CA_7C	3	See CA_3C Bandwidth Combination Set 0 in Table 5.6A.1-1				80	0	
		7	See CA_7C Bandwidth Combination Set 2 in Table 5.6A.1-1						
		3	See CA_3C Bandwidth Combination Set 0 in Table 5.6A.1-1				80	1	
		7	See CA_7C Bandwidth Combination Set 1 in Table 5.6A.1-1						
CA_3A-8A	CA_3A-8A	3		Yes	Yes	Yes	Yes	30	0
		8		Yes	Yes				
		3			Yes			20	1
		8		Yes	Yes				
		3		Yes	Yes	Yes	Yes	30	2
		8	Yes	Yes	Yes				
		3		Yes	Yes	Yes	Yes	30	3
8		Yes	Yes						
CA_3A-3A-8A	CA_3A-8A	3	See CA_3A-3A Bandwidth Combination Set 0 in table 5.6A.1-3				50	0	
		8		Yes	Yes				
		3	See CA_3A-3A Bandwidth Combination Set 1 in table 5.6A.1-3				40	1	
		8		Yes	Yes				
CA_3C-8A	CA_3A-8A, CA_3C	3	See CA_3C Bandwidth Combination Set 0 in Table 5.6A.1-1				50	0	
		8	Yes	Yes	Yes				
CA_3A-11A	CA_3A-11A	3		Yes	Yes	Yes	Yes	30	0
		11		Yes	Yes				
CA_3A-18A	CA_3A-18A	3		Yes	Yes	Yes	Yes	35	0
		18		Yes	Yes	Yes			
CA_3A-19A	CA_3A-19A	3		Yes	Yes	Yes	Yes	35	0
		19		Yes	Yes	Yes			
CA_3A-3A-19A	CA_3A-19A	3	See CA_3A-3A Bandwidth Combination Set 0 in Table 5.6A.1-3				55	0	
		19		Yes	Yes	Yes			
CA_3A-20A	CA_3A-20A	3		Yes	Yes	Yes	Yes	30	0
		20		Yes	Yes				
		3		Yes	Yes	Yes	Yes	40	1
		20		Yes	Yes	Yes	Yes		
CA_3A-3A-20A	-	3	See CA_3A-3A Bandwidth Combination Set 0 in Table 5.6A.1-3				60	0	
		20		Yes	Yes	Yes			Yes
CA_3C-20A	-	3	See CA_3C Bandwidth Combination Set 0 in Table 5.6A.1-1				60	0	
		20		Yes	Yes	Yes			Yes
CA_3A-21A	CA_3A-21A	3		Yes	Yes	Yes	Yes	35	0
		21		Yes	Yes	Yes			
CA_3A-3A-21A	CA_3A-21A	3	See CA_3A-3A Bandwidth Combination Set 0 in Table 5.6A.1-3				55	0	
		21		Yes	Yes	Yes			
CA_3A-26A	CA_3A-26A	3		Yes	Yes	Yes	Yes	35	0
		26		Yes	Yes	Yes			
		3		Yes	Yes			20	1
		26		Yes	Yes				
CA_3A-27A	-	3		Yes	Yes	Yes	Yes	30	0
		27		Yes	Yes				

CA_3A-28A	CA_3A-28A	3		Yes	Yes	Yes	Yes	40	0
		28		Yes	Yes	Yes	Yes		
		3	Yes	Yes	Yes	Yes	Yes	40	1
		28		Yes	Yes	Yes	Yes		
CA_3A-3A-28A	-	3	See CA_3A-3A Bandwidth combination set 0 in Table 5.6A.1-1					60	0
		28		Yes	Yes	Yes	Yes		
CA_3C-28A	CA_3C	3	See CA_3C Bandwidth Combination Set 0 in Table 5.6A.1-1					60	0
		28		Yes	Yes	Yes	Yes		
CA_3A-31A	-	3		Yes	Yes	Yes	Yes	25	0
		31	Yes	Yes					
CA_3A-32A	-	3		Yes	Yes	Yes	Yes	40	0
		32		Yes	Yes	Yes	Yes		
CA_3C-32A	-	3	See the CA_3C Bandwidth combination Set 0 in Table 5.6A.1-1					60	0
		32		Yes	Yes	Yes	Yes		
CA_3A-38A	-	3		Yes	Yes	Yes	Yes	40	0
		38		Yes	Yes	Yes	Yes		
CA_3C-38A	-	3	See CA_3C Bandwidth combination set 0 in Table 5.6A.1-1					60	0
		38		Yes	Yes	Yes	Yes		
CA_3A-40A	CA_3A-40A	3		Yes	Yes	Yes	Yes	40	0
		40		Yes	Yes	Yes	Yes		
		3	Yes	Yes	Yes	Yes	Yes	40	1
		40		Yes	Yes	Yes	Yes		
CA_3A-40A-40A	-	3		Yes	Yes			50	0
		40	See CA_40A-40A Bandwidth Combination Set 0 in Table 5.6A.1-3						
CA_3A-40C	-	3		Yes	Yes	Yes	Yes	60	0
		40	See CA_40C Bandwidth Combination Set 1 in Table 5.6A.1-1						
CA_3A-40D	-	3		Yes	Yes	Yes	Yes	80	0
		40	See CA_40D Bandwidth Combination Set 0 in Table 5.6A.1-1						
CA_3A-40E	-	3		Yes	Yes	Yes	Yes	100	0
		40	See CA_40E Bandwidth Combination Set 0 in Table 5.6A.1-1						
CA_3C-40A	-	3	See CA_3C Bandwidth Combination Set 0 in Table 5.6A.1-1					60	0
		40		Yes	Yes	Yes	Yes		
CA_3C-40C	-	3	See CA_3C Bandwidth Combination Set 0 in Table 5.6A.1-1					80	0
		40	See CA_40C Bandwidth Combination Set 1 in Table 5.6A.1-1						
CA_3A-41A	CA_3A-41A	3		Yes	Yes	Yes	Yes	40	0
		41		Yes	Yes	Yes	Yes		
		3	Yes	Yes	Yes	Yes	Yes	40	1
		41		Yes	Yes	Yes	Yes		
CA_3A-3A-41A	-	3		Yes	Yes	Yes	Yes	60	0
		3		Yes	Yes	Yes	Yes		
		41		Yes	Yes	Yes	Yes		
CA_3A-41C	CA_3A-41A, CA_3A-41C, CA_41C	3		Yes	Yes	Yes	Yes	60	0
		41	See CA_41C Bandwidth Combination Set 0 in Table 5.6A.1-1						
CA_3A-41D	CA_3A-41A, CA_41C	3		Yes	Yes	Yes	Yes	80	0
		41	See CA_41D Bandwidth Combination Set 0 in Table 5.6A.1-1						
CA_3C-41A	-	3	See CA_3C Bandwidth Combination Set 0 in Table 5.6A.1-1					60	0
		41		Yes	Yes	Yes	Yes		
CA_3C-41C	-	3	See CA_3C Bandwidth Combination Set 0 in Table 5.6A.1-1					80	0

		41	See CA_41C Bandwidth Combination Set 0 in Table 5.6A.1-1						
CA_3C-41D	-	3	See CA_3C Bandwidth Combination Set 0 in Table 5.6A.1-1				100	0	
		41	See CA_41D Bandwidth Combination Set 0 in Table 5.6A.1-1						
CA_3A-42A	CA_3A-42A	3		Yes	Yes	Yes	Yes	40	0
		42		Yes	Yes	Yes	Yes		
CA_3A-3A-42A	CA_3A-42A	3	See CA_3A-3A Bandwidth Combination Set 0 in Table 5.6A.1-3				60	0	
		42		Yes	Yes	Yes			Yes
CA_3A-42C	CA_3A-42A, CA_42C CA_3A-42C	3		Yes	Yes	Yes	Yes	60	0
		42	See CA_42C Bandwidth Combination Set 0 in Table 5.6A.1-1						
CA_3A-42D	CA_3A-42A	3		Yes	Yes	Yes	Yes	80	0
		42	See CA_42D Bandwidth Combination Set 0 in Table 5.6A.1-1						
CA_3A-3A-42C	CA_3A-42A	3	See CA_3A-3A Bandwidth Combination Set 0 in Table 5.6A.1-3				80	0	
		42	See CA_42C Bandwidth Combination Set 0 in Table 5.6A.1-1						
CA_3A-42A-42A	CA_3A-42A	3		Yes	Yes	Yes	Yes	60	0
		42	See CA_42A-42A Bandwidth Combination Set 0 in Table 5.6A.1-3						
CA_3A-42A-42C	CA_3A-42A, CA_42C	3		Yes	Yes	Yes	Yes	80	0
		42	See CA_42A-42C Bandwidth Combination Set 0 in Table 5.6A.1-3						
CA_3A-42C-42C	CA_3A-42A, CA_42C	3		Yes	Yes	Yes	Yes	100	0
		42	See CA_42C-42C Bandwidth Combination Set 0 in Table 5.6A.1-3						
CA_3A-42E	CA_3A-42A	3		Yes	Yes	Yes	Yes	100	0
		42	See CA_42E Bandwidth Combination Set 0 in Table 5.6A.1-1						
CA_3A-43A	-	3		Yes	Yes	Yes		35	0
		43		Yes	Yes	Yes	Yes		
CA_3A-46A	-	3		Yes	Yes	Yes	Yes	40	0
		46					Yes		
		3		Yes	Yes	Yes	Yes	40	1
		46		Yes		Yes	Yes		
CA_3A-46C	-	3		Yes	Yes	Yes	Yes	60	0
		46	See CA_46C Bandwidth Combination Set 0 in Table 5.6A.1-1						
	-	3		Yes	Yes	Yes	Yes	60	1
		46	See CA_46C Bandwidth Combination Set 1 in Table 5.6A.1-1						
CA_3A-46D	-	3		Yes	Yes	Yes	Yes	80	0
		46	See CA_46D Bandwidth combination set 0 in Table 5.6A.1-1						
		3		Yes	Yes	Yes	Yes	80	1
		46	See CA_46D Bandwidth combination set 1 in Table 5.6A.1-1						
CA_3A-46E	-	3		Yes	Yes	Yes	Yes	100	0
		46	See CA_46E Bandwidth Combination Set 0 in Table 5.6A.1-1						
		3		Yes	Yes	Yes	Yes	100	1
		46	See CA_46E Bandwidth Combination Set 1 in Table 5.6A.1-1						
CA_3A-3A-46A		3	See CA_3A-3A Bandwidth Combination Set 0 in table 5.6A.1-3				60	0	
		46				Yes			
CA_3A-3A-46C	-	3	See CA_3A-3A Bandwidth Combination Set 0 in Table 5.6A.1-3				80	0	
		46	See CA_46C Bandwidth Combination Set 0 in Table 5.6A.1-1						

CA_3C-46A	-	3	See CA_3C Bandwidth Combination Set 0 in Table 5.6A.1-1					60	0	
		46					Yes			
CA_3C-46C	-	3	See CA_3C Bandwidth Combination Set 0 in Table 5.6A.1-1					80	0	
		46	See CA_46C Bandwidth combination set 0 in Table 5.6A.1-1							
CA_3C-46D	-	3	See CA_3C Bandwidth Combination Set 0 in Table 5.6A.1-1					100	0	
		46	See CA_46D Bandwidth combination set 0 in Table 5.6A.1-1							
CA_3A-69A	-	3		Yes	Yes	Yes	Yes	40	0	
		69		Yes	Yes	Yes	Yes			
CA_4A-5A	CA_4A-5A	4		Yes	Yes			20	0	
		5		Yes	Yes					
		4		Yes	Yes	Yes	Yes	30	1	
		5		Yes	Yes					
CA_4A-4A-5A	-	4	See CA_4A-4A Bandwidth Combination Set 0 in table 5.6A.1-3					50	0	
		5		Yes	Yes					
CA_4A-5B	CA_5B	4		Yes	Yes	Yes	Yes	40	0	
		5	See CA_5B Bandwidth Combination Set 0 in Table 5.6A.1-1							
CA_4A-4A-5B	CA_4A-5A, CA_5B	4	See CA_4A-4A Bandwidth Combination Set 0 in Table 5.6A.1-3					60	0	
		5	See CA_5B Bandwidth Combination Set 0 in Table 5.6A.1-1							
CA_4A-7A	CA_4A-7A	4		Yes	Yes			30	0	
		7		Yes	Yes	Yes	Yes			
		4		Yes	Yes	Yes	Yes	40	1	
		7		Yes	Yes	Yes	Yes			
CA_4A-4A-7A	-	4		Yes	Yes			40	0	
		7		Yes	Yes	Yes	Yes			
		4		Yes	Yes	Yes	Yes			
		4		Yes	Yes	Yes	Yes	60	1	
		7		Yes	Yes	Yes	Yes			
		4		Yes	Yes	Yes	Yes			
CA_4A-7A-7A	-	4		Yes	Yes	Yes	Yes	60	0	
7	See the CA_7A-7A Bandwidth combination set 1 in Table 5.6A.1-3									
CA_4A-7C	CA_4A-7A	4		Yes	Yes	Yes	Yes	60	0	
		7	See CA_7C Bandwidth Combination Set 1 in Table 5.6A.1-1							
CA_4A-12A	CA_4A-12A	4	Yes	Yes	Yes	Yes		20	0	
		12			Yes	Yes				
		4	Yes	Yes	Yes	Yes	Yes	Yes	30	1
		12			Yes	Yes				
		4		Yes	Yes	Yes	Yes		30	2
		12		Yes	Yes					
		4		Yes	Yes				20	3
		12		Yes	Yes					
		4		Yes	Yes	Yes	Yes		30	4
		12		Yes	Yes					
4		Yes	Yes	Yes			20	5		
12		Yes								
CA_4A-4A-12A	-	4	See CA_4A-4A Bandwidth Combination Set 0 in Table 5.6A.1-3					50	0	
		12		Yes	Yes					
CA_4A-12A-12A	-	4		Yes	Yes	Yes	Yes	30	0	
12	See CA_12A-12A Bandwidth Combination Set 0 in Table 5.6A.1-3									
CA_4A-4A-12A-12A	-	4	See CA_4A-4A Bandwidth Combination Set 0 in Table 5.6A.1-3					50	0	

		12	See CA_12A-12A Bandwidth Combination Set 0 in Table 5.6A.1-3						
CA_4A-4A-12B	-	4	See CA_4A-4A Bandwidth Combination Set 0 in Table 5.6A.1-3				55	0	
		12	See CA_12B Bandwidth Combination Set 0 in Table 5.6A.1-1						
CA_4A-12B	CA_4A-12A	4		Yes	Yes	Yes	Yes	35	0
		12	See CA_12B Bandwidth Combination Set 0 in Table 5.6A.1-1						
CA_4A-13A	CA_4A-13A	4		Yes	Yes	Yes	Yes	30	0
		13			Yes				
		4		Yes	Yes			20	1
		13			Yes				
CA_4A-4A-13A	-	4	See CA_4A-4A Bandwidth Combination Set 0 in Table 5.6A.1-3				50	0	
		13			Yes				
CA_4A-17A	CA_4A-17A	4		Yes	Yes			20	0
		17		Yes	Yes				
CA_4A-27A	-	4		Yes	Yes	Yes	Yes	30	0
		27		Yes	Yes	Yes			
CA_4A-28A	CA_4A-28A	4		Yes	Yes	Yes	Yes	40	0
		28		Yes	Yes	Yes	Yes		
CA_4A-29A	-	4		Yes	Yes			20	0
		29		Yes	Yes	Yes			
		4		Yes	Yes			20	1
		29		Yes	Yes				
		4		Yes	Yes	Yes	Yes	30	2
		29		Yes	Yes				
CA_4A-4A-29A	-	4	See CA_4A-4A Bandwidth combination set 0 in Table 5.6A.1-3				50	0	
		29		Yes	Yes				
CA_4A-30A	-	4		Yes	Yes	Yes	Yes	30	0
		30		Yes	Yes				
CA_4A-4A-30A	-	4	See CA_4A-4A Bandwidth combination set 0 in Table 5.6A.1-3				50	0	
		30		Yes	Yes				
CA_4A-46A	-	4		Yes	Yes	Yes	Yes	40	0
		46					Yes		
CA_4A-46A-46A	-	4		Yes	Yes	Yes	Yes	60	0
		46	See CA_46A-46A Bandwidth combination set 0 in Table 5.6A.1-3						
CA_4A-46A-46C	-	4		Yes	Yes	Yes	Yes	80	0
		46	See CA_46A-46C Bandwidth Combination Set 0 in Table 5.6A.1-3						
CA_4A-46C	-	4		Yes	Yes	Yes	Yes	60	0
		46	See CA_46C Bandwidth Combination Set 0 in Table 5.6A.1-1						
CA_4A-46D	-	4		Yes	Yes	Yes	Yes	80	0
		46	See CA_46D Bandwidth combination set 0 in Table 5.6A.1-1						
CA_4A-46A-46D	-	4		Yes	Yes	Yes	Yes	100	0
		46	See CA_46A-46D Bandwidth combination set 0 in Table 5.6A.1-3						
CA_4A-48A	-	4		Yes	Yes	Yes	Yes	40	0
		48		Yes	Yes	Yes	Yes		
CA_4A-48C	-	4		Yes	Yes	Yes	Yes	60	0
		48	See CA_48C Bandwidth combination set 0 in Table 5.6A.1-1						
CA_4A-48D	-	4		Yes	Yes	Yes	Yes	80	0
		48	See CA_48D Bandwidth combination set 0 in Table 5.6A.1-1						
CA_4A-48E	-	4		Yes	Yes	Yes	Yes	100	0

		48	See CA_48E Bandwidth combination set 0 in Table 5.6A.1-1							
CA_4A-71A	-	4		Yes	Yes	Yes	Yes	40	0	
		71		Yes	Yes	Yes	Yes			
CA_4A-4A-71A	-	4	See CA_4A-4A Bandwidth Combination Set 0 in Table 5.6A.1-3				60	0		
		71		Yes	Yes	Yes			Yes	
CA_5A-7A	CA_5A-7A	5	Yes	Yes	Yes	Yes		30	0	
		7			Yes	Yes	Yes			Yes
		5			Yes	Yes			30	1
		7			Yes	Yes	Yes	Yes		
CA_5A-7A-7A	CA_5A-7A	5			Yes	Yes		50	0	
		7	See CA_7A-7A Bandwidth Combination Set 3 in Table 5.6A.1-3							
CA_5A-7C	-	5			Yes	Yes		50	0	
		7	See CA_7C Bandwidth Combination Set 1 in Table 5.6A.1-1							
CA_5A-12A	CA_5A-12A	5			Yes	Yes		20	0	
		12			Yes	Yes				
CA_5A-12A-12A	-	5			Yes	Yes		20	0	
		12	See CA_12A-12A Bandwidth Combination Set 0 in Table 5.6A.1-3							
CA_5A-12B	-	5			Yes	Yes		25	0	
		12	See CA_12B Bandwidth Combination Set 0 in Table 5.6A.1-1							
CA_5A-13A	-	5			Yes	Yes		20	0	
		13			Yes	Yes				
CA_5A-17A	CA_5A-17A	5			Yes	Yes		20	0	
		17			Yes	Yes				
CA_5A-25A	-	5			Yes	Yes		30	0	
		25			Yes	Yes	Yes			Yes
CA_5A-28A	-	5			Yes	Yes		30	0	
		28			Yes	Yes	Yes			Yes
CA_5A-29A	-	5			Yes	Yes		20	0	
		29			Yes	Yes				
CA_5A-30A	CA_5A-30A	5			Yes	Yes		20	0	
		30			Yes	Yes				
CA_5B-30A	-	5	See CA_5B Bandwidth combination set 0 in Table 5.6A.1-1				30	0		
		30			Yes	Yes				
CA_5A-38A	-	5			Yes	Yes		30	0	
		38			Yes	Yes	Yes			Yes
CA_5A-40A	CA_5A-40A	5			Yes	Yes		30	0	
		40			Yes	Yes	Yes			Yes
		5		Yes	Yes	Yes		30	1	
		40		Yes	Yes	Yes	Yes			
CA_5A-5A-40A	-	5	See CA_5A-5A Bandwidth Combination Set 0 in table 6.140.2-2				40	0		
		40			Yes				Yes	
CA_5A-40A-40A	-	5			Yes	Yes		50	0	
		40	See CA_40A-40A Bandwidth Combination Set 0 in Table 5.6A.1-3							
CA_5A-40C	-	5			Yes	Yes		50	0	
		40	See CA_40C Bandwidth Combination Set 1 in Table 5.6A.1-1							
		5		Yes	Yes	Yes		50	1	
		40	See CA_40C Bandwidth Combination Set 1 in Table 5.6A.1-1							
CA_5A-41A	-	5			Yes	Yes		30	0	
		41					Yes			
CA_5A-46A	-	5			Yes	Yes		30	0	
		46					Yes			
		5		Yes	Yes	Yes		30	1	



		46			Yes		Yes			
CA_5A-46C	-	5		Yes	Yes					
		46	See CA_46C Bandwidth Combination Set 0 in Table 5.6A.1-1				50	0		
CA_5A-46C	-	5		Yes	Yes					
		46	See CA_46C Bandwidth Combination Set 1 in Table 5.6A.1-1				50	1		
CA_5A-46D	-	5		Yes	Yes					
		46	See CA_46D Bandwidth combination set 0 in Table 5.6A.1-1				70	0		
		5		Yes	Yes					
CA_5A-46D	-	46	See CA_46D Bandwidth combination set 1 in Table 5.6A.1-1				70	1		
		5		Yes	Yes					
		46	See CA_46E of Bandwidth Combination Set 0 in Table 5.6A.1-1				90	0		
CA_5A-46E	-	5		Yes	Yes					
		46	See CA_46E of Bandwidth Combination Set 1 in Table 5.6A.1-1				90	1		
		5		Yes	Yes					
CA_5B-46A	-	5	See CA_5B Bandwidth combination set 0 in Table 5.6A.1-1				40	0		
		46					Yes			
CA_5B-46C	-	5	See CA_5B Bandwidth combination set 0 in Table 5.6A.1-1				60	0		
		46	See CA_46C Bandwidth combination set 0 in Table 5.6A.1-1							
CA_5B-46D	-	5	See CA_5B Bandwidth combination set 0 in Table 5.6A.1-1				80	0		
		46	See CA_46D Bandwidth combination set 0 in Table 5.6A.1-1							
CA_5B-46E	-	5	See CA_5B Bandwidth combination set 0 in Table 5.6A.1-1				100	0		
		46	See CA_46E Bandwidth combination set 0 in Table 5.6A.1-1							
CA_5A-48A	-	5		Yes	Yes					
		48		Yes	Yes	Yes	Yes			
CA_5A-48C	-	5		Yes	Yes					
		48	See CA_48C Bandwidth combination set 0 in Table 5.6A.1-1				50	0		
CA_5A-48D	-	5		Yes	Yes					
		48	See CA_48D Bandwidth combination set 0 in the Table 5.6A.1-1				70	0		
CA_5A-66A	CA_5A-66A	5		Yes	Yes					
		66		Yes	Yes	Yes	Yes			
CA_5A-5A-66A	CA_5A-66A	5	See CA_5A-5A Bandwidth combination set 0 in Table 5.6A.1-3				40	0		
		66		Yes	Yes	Yes	Yes			
CA_5A-5A-66A-66A	CA_5A-66A	5	See CA_5A-5A Bandwidth Combination Set 0 in Table 5.6A.1-3				60	0		
		66	See CA_66A-66A Bandwidth combination set 0 in Table 5.6A.1-3							
CA_5A-5A-66A-66B	CA_5A-66A, CA_66B	5	See CA_5A-5A Bandwidth Combination Set 0 in Table 5.6A.1-3				60	0		
		66	See CA_66A-66B Bandwidth combination set 0 in Table 5.6A.1-3							
CA_5A-5A-66A-66C	CA_5A-66A	5	See CA_5A-5A Bandwidth Combination Set 0 in Table 5.6A.1-3				80	0		
		66	See CA_66A-66C Bandwidth Combination set 0 in Table 5.6A.1-3							
CA_5A-5A-66B	CA_5A-66A, CA_66B	5	See CA_5A-5A Bandwidth Combination Set 0 in Table 5.6A.1-3				40	0		
		66	See CA_66B Bandwidth combination set 0 in Table 5.6A.1-1							
CA_5A-5A-66C	CA_5A-66A	5	See CA_5A-5A Bandwidth Combination Set 0 in Table 5.6A.1-3				60	0		

		66	See CA_66C Bandwidth combination set 0 in Table 5.6A.1-1						
CA_5A-5A-66D	CA_5A-66A	5	See CA_5A-5A Bandwidth Combination Set 0 in Table 5.6A.1-3	80	0				
		66	See CA_66D Bandwidth combination set 0 in Table 5.6A.1-1						
CA_5A-66A-66A	CA_5A-66A	5	Yes Yes	50	0				
		66	See CA_66A-66A Bandwidth combination set 0 in Table 5.6A.1-3						
CA_5A-66A-66C	CA_5A-66A	5	Yes Yes	70	0				
		66	See CA_66A-66C Bandwidth combination set 0 in Table 5.6A.1-3						
CA_5A-66B	CA_66B	5	Yes Yes	30	0				
		66	See CA_66B Bandwidth combination set 0 in Table 5.6A.1-1						
CA_5A-66C	-	5	Yes Yes	50	0				
		66	See CA_66C Bandwidth combination set 0 in Table 5.6A.1-1						
CA_5A-66D	-	5	Yes Yes	70	0				
		66	See CA_66D Bandwidth combination set 0 in Table 5.6A.1-1						
CA_5B-66A	CA_5B	5	See CA_5B Bandwidth combination set 0 in Table 5.6A.1-1	40	0				
		66	Yes Yes Yes Yes						
CA_5B-66A-66A	-	5	See CA_5B Bandwidth Combination Set 0 in Table 5.6A.1-1	60	0				
		66	See CA_66A-66A Bandwidth Combination Set 0 in Table 5.6A.1-3						
CA_5A-66A-66B	CA_66B	5	Yes Yes	50	0				
		66	See CA_66A-66B Bandwidth combination set 0 in Table 5.6A.1-3						
CA_5B-66A-66B	-	5	See CA_5B Bandwidth Combination Set 0 in Table 5.6A.1-1	60	0				
		66	See CA_66A-66B Bandwidth Combination Set 0 in Table 5.6A.1-3						
CA_5B-66A-66C	-	5	See CA_5B Bandwidth Combination Set 0 in Table 5.6A.1-1	80	0				
		66	See CA_66A-66C Bandwidth Combination Set 0 in Table 5.6A.1-3						
CA_5B-66B	CA_5B, CA_66B	5	See CA_5B Bandwidth Combination Set 0 in Table 5.6A.1-1	40	0				
		66	See CA_66B Bandwidth combination set 0 in Table 5.6A.1-1						
CA_5B-66C	-	5	See CA_5B Bandwidth Combination Set 0 in Table 5.6A.1-1	60	0				
		66	See CA_66C Bandwidth combination set 0 in Table 5.6A.1-1						
CA_7A-8A	CA_7A-8A	7	Yes Yes Yes Yes	30	0				
		8	Yes Yes						
		7	Yes Yes Yes						
		8	Yes Yes						
		7	Yes Yes Yes Yes						
CA_7A-7A-8A	CA_7A-8A	7	See CA_7A-7A Bandwidth Combination Set 1 in Table 5.6A.1-3	50	0				
		8	Yes Yes						
		7	See CA_7A-7A Bandwidth Combination Set 2 in Table 5.6A.1-3						
		8	Yes Yes						
		7	Yes Yes Yes Yes						
CA_7A-12A	-	7	Yes Yes Yes Yes	30	0				
		12	Yes Yes						
CA_7A-12B	-	7	Yes Yes Yes Yes	35	0				
		12	See CA_12B Bandwidth combination set 0 in Table 5.6A.1-1						
CA_7A-13A	-	7	Yes Yes Yes Yes	30	0				

		13		Yes	Yes					
CA_7C-13A	-	7	See CA_7C Bandwidth combination set 1 in Table 5.6A.1-1					50	0	
		13		Yes	Yes					
CA_7A-7A-13A	-	7	See CA_7A-7A Bandwidth combination set 1 in Table 5.6A.1-3					50	0	
		13		Yes	Yes					
CA_7A-20A	CA_7A-20A	7			Yes	Yes		30	0	
		20			Yes	Yes				
		7			Yes	Yes	Yes	Yes	40	1
		20			Yes	Yes	Yes	Yes		
		7			Yes	Yes	Yes	Yes	40	2
20			Yes	Yes	Yes	Yes				
CA_7A-7A-20A	-	7	See CA_7A-7A Bandwidth Combination Set 3 in Table 5.6A.1-3					60	0	
		20			Yes	Yes	Yes			Yes
CA_7C-20A	-	7	See CA_7C Bandwidth Combination Set 1 in table 5.6A.1-1					60	0	
		20			Yes	Yes	Yes			Yes
CA_7A-22A	-	7			Yes	Yes	Yes	40	0	
		22			Yes	Yes	Yes			Yes
CA_7A-26A	CA_7A-26A	7			Yes	Yes	Yes	35	0	
		26			Yes	Yes	Yes			
CA_7A-7A-26A	CA_7A-26A	7	See CA_7A-7A bandwidth combination set 3 in table 5.6A.1-3					55	0	
		26			Yes	Yes	Yes			
CA_7A-28A	CA_7A-28A	7			Yes	Yes	Yes	35	0	
		28			Yes	Yes	Yes			Yes
		7			Yes	Yes	Yes	Yes	40	1
		28			Yes	Yes	Yes	Yes		
CA_7A-7A-28A	-	7	See CA_7A-7A Bandwidth combination set 3 in Table 5.6A.1-3					60	0	
		28			Yes	Yes	Yes			
CA_7B-28A	-	7	See CA_7B bandwidth combination set 0 in table 5.6A.1-1					40	0	
		28			Yes	Yes	Yes			Yes
CA_7C-28A	CA_7A-28A CA_7C	7	See CA_7C bandwidth combination set 2 in table 5.6A.1-1					60	0	
		28			Yes	Yes	Yes			Yes
		7	See CA_7C Bandwidth Combination Set 1 in Table 5.6A.1-1					60	1	
		28			Yes	Yes	Yes			Yes
CA_7A-29A	-	7			Yes	Yes	Yes	30	0	
		29			Yes	Yes				
CA_7A-7A-29A	-	7	See CA_7A-7A Bandwidth combination set 1 in table 5.6A.1-3 of 36.101					50	0	
		29			Yes	Yes				
CA_7C-29A	-	7	See CA_7C Bandwidth combination set 2 in table 5.6A.1-1 of 36.101					50	0	
		29			Yes	Yes				
CA_7A-30A	-	7			Yes	Yes	Yes	30	0	
		30			Yes	Yes				
CA_7A-32A	-	7			Yes	Yes	Yes	40	0	
		32			Yes	Yes	Yes			Yes
CA_7A-40A	-	7			Yes	Yes	Yes	40	0	
		40			Yes	Yes	Yes			Yes
CA_7A-40C	-	7			Yes	Yes	Yes	60	0	
		40	See CA_40C Bandwidth Combination Set 1 in Table 5.6A.1-1							
CA_7A-40D	-	7			Yes	Yes	Yes	80	0	
		40	See CA_40D Bandwidth combination set 0 in Table 5.6A.1-1							
CA_7A-40E	-	7			Yes	Yes	Yes	Yes	100	0

		40	See CA_40E Bandwidth combination set 0 in Table 5.6A.1-1							
CA_7A-42A	-	7		Yes	Yes	Yes	Yes	40	0	
		42		Yes	Yes	Yes	Yes			
CA_7A-42A-42A	-	7		Yes	Yes	Yes	Yes	60	0	
		42	See CA_42A-42A Bandwidth Combination Set 0 in Table 5.6A.1-3							
CA_7A-46A	-	7		Yes	Yes	Yes	Yes	40	0	
		46					Yes			
		7		Yes	Yes	Yes	Yes			40
46			Yes		Yes					
CA_7A-7A-46C	-	7	See CA_7A-7A Bandwidth Combination Set 1 in Table 5.6A.1-3				80	0		
		46	See CA_46C Bandwidth Combination Set 1 in Table 5.6A.1-1							
CA_7A-46C	-	7		Yes	Yes	Yes	Yes	60	0	
		46	See CA_46C Bandwidth Combination Set 0 in Table 5.6A.1-1							
	-	7		Yes	Yes	Yes	Yes	60	1	
		46	See CA_46C Bandwidth Combination Set 1 in Table 5.6A.1-1							
CA_7A-46D	-	7		Yes	Yes	Yes	Yes	80	0	
		46	See CA_46D Bandwidth Combination Set 0 in Table 5.6A.1-1							
		-	7		Yes	Yes	Yes	Yes	80	1
			46	See CA_46D Bandwidth Combination Set 1 in Table 5.6A.1-1						
CA_7A-46E	-	7		Yes	Yes	Yes	Yes	100	0	
		46	See CA_46E Bandwidth Combination Set 0 in Table 5.6A.1-1							
CA_7A-7A-46E	-	7	See CA_7A-7A Bandwidth combination set 1 in table 5.6A.1-3 of 36.101				120	0		
		46	See CA_46E Bandwidth combination set 0 in table 5.6A.1-3 of 36.101							
CA_7C-46C	-	7	See CA_7C Bandwidth Combination Set 2 in Table 5.6A.1-1				80	0		
		46	See CA_46C Bandwidth Combination Set 0 in Table 5.6A.1-1							
CA_7C-46D	-	7	See CA_7C Bandwidth Combination Set 2 in Table 5.6A.1-1				100	0		
		46	See CA_46D Bandwidth Combination Set 0 in Table 5.6A.1-1							
CA_7C-46E	-	7	See CA_7C Bandwidth Combination Set 2 in Table 5.6A.1-1				120	0		
		46	See CA_46E Bandwidth Combination Set 0 in Table 5.6A.1-1							
CA_7A-7A-46A	-	7	See CA_7A-7A Bandwidth Combination Set 1 in table 5.6A.1-3				60	0		
		46							Yes	
CA_7A-7A-46D	-	7	See CA_7A-7A Bandwidth Combination Set 1 in table 5.6A.1-3				100	0		
		46	See CA_46D Bandwidth combination set 0 in Table 5.6A.1-1							
CA_7A-66A	-	7		Yes	Yes	Yes	Yes	40	0	
		66		Yes	Yes	Yes	Yes			
CA_7A-7A-66A-66A	-	7	See CA_7A-7A Bandwidth combination set 1 in table 5.6A.1-3				80	0		
		66	See CA_66A-66A Bandwidth Combination Set 0 in Table 5.6A.1-3							
CA_7C-66A	-	7	See CA_7C Bandwidth Combination Set 1 in Table 5.6A.1-1				60	0		
		66		Yes	Yes	Yes			Yes	
CA_7C-46A	-	7	See CA_7C Bandwidth Combination set 2 in Table 5.6A.1-1				60	0		
		46							Yes	

CA_7A-7A-66A	-	7	See CA_7A-7A Bandwidth combination set 1 in table 5.6A.1-3					60	0	
		66		Yes	Yes	Yes	Yes			
CA_7A-66A-66A	-	7		Yes	Yes	Yes	Yes	60	0	
		66	See CA_66A-66A Bandwidth Combination Set 0 in Table 5.6A.1-3							
CA_7C-66A-66A	-	7	See CA_7C Bandwidth Combination Set 1 in Table 5.6A.1-1					80	0	
		66	See CA_66A-66A Bandwidth Combination Set 0 in Table 5.6A.1-3							
CA_8A-11A	-	8			Yes	Yes		20	0	
		11			Yes	Yes				
CA_8A-20A	-	8			Yes	Yes		20	0	
		20			Yes	Yes				
		8		Yes	Yes	Yes		20	1	
		20			Yes	Yes				
		8			Yes	Yes		30	2	
		20			Yes	Yes	Yes			Yes
CA_8A-27A	-	8			Yes	Yes		20	0	
		27			Yes	Yes				
CA_8A-28A	-	8		Yes	Yes	Yes		30	0	
		28			Yes	Yes	Yes			Yes
CA_8A-32A	-	8		Yes	Yes	Yes		30	0	
		32			Yes	Yes	Yes			Yes
CA_8A-38A	-	8			Yes	Yes		30	0	
		38			Yes	Yes	Yes			Yes
CA_8A-39A	CA_8A-39A	8	Yes	Yes	Yes	Yes		30	0	
		39			Yes	Yes	Yes			Yes
CA_8A-39C	-	8	Yes	Yes	Yes	Yes		45	0	
		39	See CA_39C Bandwidth Combination Set 0 in Table 5.6A.1-1							
CA_8B-39A	-	8	See CA_8B Bandwidth Combination Set 0 in Table 5.6A.1-1					40	0	
		39			Yes	Yes	Yes			Yes
CA_8B-39C	-	8	See CA_8B Bandwidth Combination Set 0 in Table 5.6A.1-1					55	0	
		39	See CA_39C Bandwidth Combination Set 0 in Table 5.6A.1-1							
CA_8A-40A	-	8			Yes	Yes		30	0	
		40			Yes	Yes	Yes			Yes
	-	8		Yes	Yes	Yes		30	1	
		40			Yes	Yes	Yes			Yes
CA_8A-40C	-	8			Yes	Yes		50	0	
		40	See CA_40C Bandwidth combination set 1 in Table 5.6A.1-1							
CA_8A-41A	CA_8A-41A	8	Yes	Yes	Yes	Yes		30	0	
		41				Yes				Yes
		8			Yes	Yes			30	1
		41			Yes	Yes	Yes	Yes		
CA_8A-41C	-	8	Yes	Yes	Yes	Yes		50	0	
		41	See CA_41C bandwidth combination set 3 in table 5.6A.1-1							
CA_8A-41D	-	8	Yes	Yes	Yes	Yes		70	0	
		41	See CA_41D bandwidth combination set 0 in table 5.6A.1-1							
CA_8B-41A	-	8	See CA_8B Bandwidth combination set 0 in Table 5.6A.1-1					40	0	
		41								Yes
CA_8B-41C	-	8	See CA_8B bandwidth combination set 0 in table 5.6A.1-1					60	0	
		41	See CA_41C bandwidth combination set 3 in table 5.6A.1-1							

CA_8B-41D	-	8	See CA_8B bandwidth combination set 0 in table 5.6A.1-1					80	0
		41	See CA_41D bandwidth combination set 0 in table 5.6A.1-1						
CA_8A-42A	-	8	Yes	Yes	Yes	Yes		30	0
		42			Yes	Yes	Yes		
CA_8A-42C	-	8	Yes	Yes	Yes	Yes		50	0
		42	See CA_42C Bandwidth Combination Set 0 in Table 5.6A.1-1						
CA_8A-46A	-	8	Yes	Yes	Yes	Yes		30	0
		46					Yes		
CA_8A-46C	-	8	Yes	Yes	Yes	Yes		50	0
		46	See CA_46C Bandwidth Combination Set 0 in Table 5.6A.1-1						
CA_8A-46D	-	8	Yes	Yes	Yes	Yes		70	0
		46	See CA_46D Bandwidth Combination Set 0 in Table 5.6A.1-1						
CA_8A-46E	-	8	Yes	Yes	Yes	Yes		90	0
		46	See CA_46E Bandwidth Combination Set 0 in Table 5.6A.1-1						
CA_8B-46A	-	8	See CA_8B Bandwidth Combination Set 0 in Table 5.6A.1-1					40	0
		46					Yes		
CA_8B-46C	-	8	See CA_8B bandwidth combination set 0 in table 5.6A.1-1					60	0
		46	See CA_46C Bandwidth Combination Set 0 in Table 5.6A.1-1						
CA_8B-46D	-	8	See CA_8B Bandwidth Combination Set 0 in Table 5.6A.1-1					80	0
		46	See CA_46D Bandwidth Combination Set 0 in Table 5.6A.1-1						
CA_11A-18A	CA_11A-18A	11			Yes	Yes		25	0
		18			Yes	Yes	Yes		
CA_11A-26A	CA_11A-26A	11			Yes	Yes		25	0
		26			Yes	Yes	Yes		
CA_11A-28A	-	11			Yes	Yes		30	0
		28			Yes	Yes	Yes		
CA_11A-41A	-	11			Yes	Yes		30	0
		41			Yes	Yes	Yes		
CA_11A-41C	-	11			Yes	Yes		50	0
		41	See CA_41C bandwidth combination set 0 in table 5.6A.1-1						
CA_11A-42A	-	11			Yes	Yes		30	0
		42			Yes	Yes	Yes		
CA_11A-42C	-	11			Yes	Yes		50	0
		42	See CA_42C Bandwidth Combination Set 0 in Table 5.6A.1-1						
CA_11A-46A	-	11			Yes	Yes		30	0
		46					Yes		
CA_11A-46C	-	11			Yes	Yes		50	0
		46	See CA_46C Bandwidth Combination Set 0 in Table 5.6A.1-1						
CA_11A-46D	-	11			Yes	Yes		70	0
		46	See CA_46D Bandwidth Combination Set 0 in Table 5.6A.1-1						
CA_11A-46E	-	11			Yes	Yes		90	0
		46	See CA_46E Bandwidth Combination Set 0 in Table 5.6A.1-1						
CA_12A-25A	-	12			Yes	Yes		30	0
		25			Yes	Yes	Yes		
CA_12A-30A	CA_12A-30A	12			Yes	Yes		20	0
		30			Yes	Yes			
CA_12A-46A	-	12			Yes	Yes		30	0
		46					Yes		

CA_12A-48A		12			Yes	Yes			30	0
		48			Yes	Yes	Yes	Yes		
CA_12A-46C	-	12			Yes	Yes			50	0
		46	See CA_46C Bandwidth Combination Set 0 in Table 5.6A.1-1							
CA_12A-46D	-	12			Yes	Yes			70	0
		46	See CA_46D Bandwidth Combination Set 0 in Table 5.6A.1-1							
CA_12A-46E	-	12			Yes	Yes			90	0
		46	See CA_46E Bandwidth Combination Set 0 in Table 5.6A.1-1							
CA_12A-48C	-	12			Yes	Yes			50	0
		48	See CA_48C Bandwidth combination set 0 in Table 5.6A.1-1							
CA_12A-48D	-	12			Yes	Yes			70	0
		48	See CA_48D Bandwidth combination set 0 in the Table 5.6A.1-1							
CA_12A-48E	-	12			Yes	Yes			90	0
		48	See CA_48E Bandwidth combination set 0 in the Table 5.6A.1-1							
CA_12A-66A	CA_12A-66A	12			Yes	Yes			20	0
		66	Yes	Yes	Yes	Yes				
		12			Yes	Yes			30	1
		66	Yes	Yes	Yes	Yes	Yes	Yes		
		12		Yes	Yes	Yes			30	2
		66		Yes	Yes	Yes	Yes	Yes		
		12			Yes	Yes			20	3
		66			Yes	Yes				
		12			Yes	Yes			30	4
		66			Yes	Yes	Yes	Yes		
12			Yes				20	5		
66			Yes	Yes	Yes					
CA_12A-66A-66A	-	12			Yes	Yes		50	0	
66	See CA_66A-66A Bandwidth combination set 0 in Table 5.6A.1-3									
CA_12A-66C	-	12			Yes	Yes		50	0	
		66	See CA_66C Bandwidth combination set 0 in Table 5.6A.1-1							
CA_12B-66A	-	12	See CA_12B bandwidth combination set 0 in table 5.6A.1-1						35	0
		66			Yes	Yes	Yes	Yes		
CA_12B-66A-66A	-	12	See CA_12B Bandwidth Combination Set 0 in Table 5.6A.1-1						55	0
		66	See CA_66A-66A Bandwidth Combination Set 0 in Table 5.6A.1-3							
CA_13A-46A	-	13			Yes	Yes		30	0	
		46					Yes			
CA_13A-46A-46A	-	13			Yes	Yes		50	0	
		46	See CA_46A-46A Bandwidth combination set 0 in Table 5.6A.1-3							
CA_13A-46A-46C	-	13			Yes	Yes		70	0	
		46	See CA_46A-46C Bandwidth Combination Set 0 in Table 5.6A.1-3							
CA_13A-46A-46D	-	13			Yes	Yes		90	0	
		46	See CA_46A-46D Bandwidth Combination Set 0 in Table 5.6A.1-3							
CA_13A-46C	-	13			Yes	Yes		50	0	
		46	See CA_46C Bandwidth Combination Set 0 in Table 5.6A.1-1							
CA_13A-46D	-	13			Yes	Yes		70	0	
		46	See CA_46D Bandwidth combination set 0 in Table 5.6A.1-1							
CA_13A-46E	-	13			Yes	Yes		90	0	

		46	See CA_46E Bandwidth combination set 0 in Table 5.6A.1-1						
CA_13A-48A	-	13		Yes	Yes			30	0
		48		Yes	Yes	Yes	Yes		
CA_13A-48A-48A	-	13		Yes	Yes			50	0
		48	See CA_48A-48A Bandwidth combination set 0 in Table 5.6A.1-3						
CA_13A-48A-48C	-	13		Yes	Yes			70	0
		48	See the CA_48A-48C Bandwidth combination set 0 in the Table 5.6A.1-3						
CA_13A-48A-48D	-	13		Yes	Yes			90	0
		48	See CA_48A-48D Bandwidth Combination Set 0 in Table 5.6A.1-3						
CA_13A-48C-48C	-	13		Yes	Yes			90	0
		48	See CA_48C-48C Bandwidth Combination Set 0 in Table 5.6A.1-3						
CA_13A-48C	-	13		Yes	Yes			50	0
		48	See CA_48C Bandwidth combination set 0 in Table 5.6A.1-1						
CA_13A-48D	-	13		Yes	Yes			70	0
		48	See the CA_48D Bandwidth combination set 0 in the Table 5.6A.1-1						
CA_13A-48E	-	13		Yes	Yes			90	0
		48	See CA_48E Bandwidth Combination Set 0 in Table 5.6A.1-1						
CA_13A-66A	CA_13A-66A	13		Yes	Yes			30	0
		66		Yes	Yes	Yes	Yes		
CA_13A-66A-66A	CA_13A-66A	13		Yes	Yes			50	0
		66	See CA_66A-66A Bandwidth combination set 0 in Table 5.6A.1-3						
CA_13A-66A-66B	-	13		Yes	Yes			50	0
		66	See CA_66A-66B Bandwidth combination set 0 in Table 5.6A.1-3						
CA_13A-66A-66C	-	13		Yes	Yes			70	0
		66	See CA_66A-66C Bandwidth combination set 0 in Table 5.6A.1-3						
CA_13A-66B	CA_13A-66A	13		Yes	Yes			30	0
		66	See CA_66B Bandwidth combination set 0 in Table 5.6A.1-1						
CA_13A-66C	CA_13A-66A	13		Yes	Yes			50	0
		66	See CA_66C Bandwidth combination set 0 in Table 5.6A.1-1						
CA_13A-66D	-	13		Yes	Yes			70	0
		66	See CA_66D Bandwidth combination set 0 in Table 5.6A.1-1						
CA_14A-30A	CA_14A-30A	14		Yes	Yes			20	0
		30		Yes	Yes				
CA_14A-66A	CA_14A-66A	14		Yes	Yes			30	0
		66		Yes	Yes	Yes	Yes		
CA_14A-66A-66A	CA_14A-66A	14		Yes	Yes			50	0
		66	See CA_66A-66A Bandwidth Combination Set 0 in Table 5.6A.1-3						
CA_14A-66A-66A-66A	CA_14A-66A	14		Yes	Yes			70	0
		66	See CA_66A-66A-66A Bandwidth Combination Set 0 in Table 5.6A.1-4						
CA_18A-28A	CA_18A-28A	18		Yes	Yes	Yes		25	0
		28		Yes	Yes				
CA_18A-41A	-	18		Yes	Yes	Yes		35	0
		41		Yes	Yes	Yes	Yes		
CA_18C-41C	CA_18C-41C	18		Yes	Yes	Yes		55	0
		41	See CA_41C Bandwidth Combination Set 1 in Table 5.6A.1-1						
CA_18A-41A	CA_18A-41A	18		Yes	Yes	Yes		35	0
		41		Yes	Yes	Yes	Yes		



CA_18A-41C	CA_18A-41A CA_18A-41C	18		Yes	Yes	Yes		55	0
		41	See CA_41C Bandwidth Combination Set 1 in Table 5.6A.1-1						
CA_18A-42A	-	18		Yes	Yes	Yes		35	0
		42		Yes	Yes	Yes	Yes		
CA_18A-42C	-	18		Yes	Yes	Yes		55	0
		42	See the CA_42C Bandwidth combination set 0 in Table 5.6A.1-1						
CA_19A-21A	CA_19A-21A	19		Yes	Yes	Yes		30	0
		21		Yes	Yes	Yes			
CA_19A-28A	-	19		Yes	Yes	Yes		25	0
		28		Yes	Yes	Yes			
CA_19A-42A	CA_19A-42A	19		Yes	Yes	Yes		35	0
		42		Yes	Yes	Yes	Yes		
CA_19A-42C	CA_19A-42A	19		Yes	Yes	Yes		55	0
		42	See CA_42C Bandwidth Combination Set 0 in Table 5.6A.1-1						
CA_19A-42D	-	19		Yes	Yes	Yes		75	0
		42	See CA_42D Bandwidth Combination Set 0 in Table 5.6A.1-1						
CA_19A-46A	-	19		Yes	Yes	Yes		35	0
		46					Yes		
CA_19A-46C	-	19		Yes	Yes	Yes		55	0
		46	See CA_46C Bandwidth Combination Set 0 in Table 5.6A.1-1						
CA_19A-46D	-	19		Yes	Yes	Yes		75	0
		46	See CA_46D Bandwidth Combination Set 0 in Table 5.6A.1-1						
CA_19A-46E	-	19		Yes	Yes	Yes		95	0
		46	See CA_46E Bandwidth Combination Set 0 in Table 5.6A.1-1						
CA_20A-28A <sup>7</sup>	-	20			Yes	Yes	Yes	40	0
		28		Yes	Yes	Yes	Yes		
CA_20A-31A	-	20		Yes	Yes	Yes	Yes	25	0
		31	Yes	Yes					
CA_20A-32A	-	20		Yes	Yes			30	0
		32		Yes	Yes	Yes	Yes		
		20		Yes	Yes	Yes	Yes		
CA_20A-38A	-	32		Yes	Yes	Yes	Yes	40	1
		20		Yes	Yes	Yes	Yes		
CA_20A-38C	-	38		Yes	Yes	Yes	Yes	40	0
		20		Yes	Yes	Yes	Yes		
CA_20A-40A	-	20		Yes	Yes	Yes	Yes	60	0
		38	See CA_38C Bandwidth Combination Set 0 in Table 5.6A.1-1						
CA_20A-40A-40A	-	20		Yes	Yes	Yes	Yes	40	0
		40		Yes	Yes	Yes	Yes		
		20		Yes	Yes	Yes			
		40		Yes	Yes	Yes	Yes		
CA_20A-40C	-	20		Yes	Yes	Yes		55	0
		40	See CA_40C Bandwidth Combination Set 1 in Table 5.6A.1-1						
CA_20A-40D	-	20		Yes	Yes	Yes		75	0
		40	See CA_40D Bandwidth Combination Set 1 in Table 5.6A.1-1						
CA_20A-41A	-	20		Yes	Yes	Yes	Yes	40	0
		41		Yes	Yes	Yes	Yes		
CA_20A-41C	-	20		Yes	Yes	Yes	Yes	60	0
		41	See CA_41C in Table 5.6A.1-1 of 36.101 Bandwidth combination set 1						
CA_20A-41D	-	20		Yes	Yes	Yes	Yes	80	0

		41	See CA_41D in Table 5.6A.1-1 of 36.101 Bandwidth combination set 0						
CA_20A-42A	-	20		Yes	Yes	Yes	Yes	40	0
		42		Yes	Yes	Yes	Yes		
CA_20A-42A-42A	-	20		Yes	Yes	Yes	Yes	60	0
		42	See CA_42A-42A Bandwidth Combination Set 0 in Table 5.6A.1-3						
CA_20A-43A	-	20		Yes				25	0
		43		Yes	Yes	Yes	Yes		
CA_20A-67A	-	20		Yes	Yes	Yes	Yes	40	0
		67		Yes	Yes	Yes	Yes		
CA_20A-75A	-	20		Yes	Yes	Yes	Yes	40	0
		75		Yes	Yes	Yes	Yes		
CA_20A-76A	-	20		Yes	Yes	Yes	Yes	25	0
		76		Yes					
CA_21A-28A	CA_21A-28A	21		Yes	Yes	Yes		25	0
		28		Yes	Yes				
CA_21A-42A	CA_21A-42A	21		Yes	Yes	Yes		35	0
		42		Yes	Yes	Yes	Yes		
CA_21A-42C	CA_21A-42A	21		Yes	Yes	Yes		55	0
		42	See CA_42C Bandwidth Combination Set 0 in Table 5.6A.1-1						
CA_21A-42D	-	21		Yes	Yes	Yes		75	0
		42	See CA_42D Bandwidth Combination Set 0 in Table 5.6A.1-1						
CA_21A-42E	-	21		Yes	Yes	Yes		95	0
		42	See CA_42E Bandwidth Combination Set 0 in Table 5.6A.1-1						
CA_21A-46A	-	21		Yes	Yes	Yes		35	0
		46					Yes		
CA_21A-46C	-	21		Yes	Yes	Yes		55	0
		46	See CA_46C Bandwidth Combination Set 0 in Table 5.6A.1-1						
CA_21A-46D	-	21		Yes	Yes	Yes		75	0
		46	See CA_46D Bandwidth Combination Set 0 in Table 5.6A.1-1						
CA_21A-46E	-	21		Yes	Yes	Yes		95	0
		46	See CA_46E Bandwidth Combination Set 0 in Table 5.6A.1-1						
CA_23A-29A	-	23		Yes	Yes	Yes	Yes	30	0
		29		Yes	Yes	Yes			
		23		Yes	Yes			20	1
		29		Yes	Yes	Yes			
CA_25A-26A	CA_25A-26A	25		Yes	Yes	Yes	Yes	35	0
		26	Yes	Yes	Yes	Yes	Yes		
		25		Yes	Yes	Yes		20	1
		26		Yes	Yes	Yes			
		25		Yes	Yes			20	2
		26		Yes	Yes				
CA_25A-25A-26A	CA_25A-26A	25	See CA_25A-25A Bandwidth Combination Set 1 in Table 5.6A.1-3				45	0	
		26	Yes	Yes					
CA_25A-41A	CA_25A-41A	25		Yes	Yes	Yes	Yes	40	0
		41		Yes	Yes	Yes	Yes		
CA_25A-25A-41A	CA_25A-41A	25	See CA_25A-25A Bandwidth Combination Set 1 in Table 5.6A.1-3				60	0	
		41		Yes	Yes	Yes			Yes
CA_25A-41C	CA_25A-41A	25		Yes	Yes	Yes	Yes	60	0
		41	See CA_41C Bandwidth Combination Set 1 in Table 5.6A.1-1						
CA_25A-25A-41C	CA_25A-41A	25	See CA_25A-25A Bandwidth Combination Set 1 in Table 5.6A.1-3				80	0	
		41	See CA_41C Bandwidth Combination Set 0 in Table 5.6A.1-1						

CA_25A-41D	CA_25A-41A	25		Yes	Yes	Yes	Yes	80	0
		41	See CA_41D Bandwidth Combination Set 0 in Table 5.6A.1-1						
CA_25A-25A-41D	CA_25A-41A	25	See CA_25A-25A Bandwidth Combination Set 1 in Table 5.6A.1-3					100	0
		41	See CA_41D bandwidth combination set 0 in table 5.6A.1-1						
CA_25A-41E	CA_25A-41A	25		Yes	Yes	Yes	Yes	100	0
		41	See CA_41E Bandwidth Combination Set 0 in Table 5.6A.1-1						
CA_25A-25A-41E	CA_25A-41A	25	See CA_25A-25A Bandwidth Combination Set 1 in Table 5.6A.1-3					120	0
		41	See CA_41E bandwidth combination set 0 in table 5.6A.1-1						
CA_25A-41F	CA_25A-41A	25		Yes	Yes	Yes	Yes	120	0
		41	See CA_41F Bandwidth Combination Set 0 in Table 5.6A.1-1						
CA_25A-25A-41F	CA_25A-41A	25	See CA_25A-25A Bandwidth Combination Set 1 in Table 5.6A.1-3					140	0
		41	See CA_41F bandwidth combination set 0 in table 5.6A.1-1						
CA_25A-46A	-	25		Yes	Yes	Yes	Yes	40	0
		46							
CA_25A-46C	-	25		Yes	Yes	Yes	Yes	60	0
		46	See CA_46C Bandwidth combination set 1 in Table 5.6A.1-1						
CA_25A-46D	-	25		Yes	Yes	Yes	Yes	80	0
		46	See CA_46D Bandwidth combination set 1 in Table 5.6A.1-1						
CA_26A-41A	-	26		Yes	Yes	Yes		35	0
		41		Yes	Yes	Yes	Yes		
CA_26A-41C	-	26		Yes	Yes	Yes		55	0
		41	See CA_41C Bandwidth Combination Set 1 in Table 5.6A.1-1						
CA_26A-46A	CA_26A-46A	26		Yes	Yes	Yes		30	0
		46					Yes		
CA_26A-48A	CA_26A-48A	26		Yes	Yes	Yes		30	0
		48		Yes	Yes	Yes	Yes		
CA_26A-48C	CA_26A-48A	26		Yes	Yes	Yes		50	0
		48	See CA_48C Bandwidth combination set 0 in the Table 5.6A.1-1						
CA_26A-48A-48A	CA_26A-48A	26		Yes	Yes	Yes		50	0
		48	See CA_48A-48A Bandwidth combination set 0 in the Table 5.6A.1-3						
Ca_26A-66A	-	26		Yes	Yes	Yes		35	0
		66		Yes	Yes	Yes	Yes		
CA_28A-32A	-	28		Yes	Yes	Yes	Yes	40	0
		32		Yes	Yes	Yes	Yes		
CA_28A-38A		28		Yes	Yes	Yes	Yes	40	0
		38		Yes	Yes	Yes	Yes		
CA_28A-40A	-	28		Yes	Yes	Yes	Yes	40	0
		40		Yes	Yes	Yes	Yes		
CA_28A-40C	-	28		Yes	Yes	Yes	Yes	60	0
		40	See CA_40C Bandwidth Combination set 1 in Table 5.6A.1-1						
CA_28A-40D	-	28		Yes	Yes	Yes	Yes	80	0
		40	See CA_40D Bandwidth Combination Set 0 in Table 5.6A.1-1						
CA_28A-41A	CA_28A-41A	28		Yes	Yes			30	0
		41		Yes	Yes	Yes	Yes		
		28		Yes	Yes	Yes	Yes		
CA_28A-41C		41		Yes	Yes	Yes	Yes	40	1
		28		Yes	Yes				
CA_28A-41C		28		Yes	Yes			50	0

		41	See CA_41C Bandwidth Combination set 0 in Table 5.6A.1-1						
CA_28A-42A	CA_28A-42A	28		Yes	Yes	Yes	Yes	40	0
		42		Yes	Yes	Yes	Yes		
CA_28A-42C	CA_28A-42A, CA_42C	28		Yes	Yes	Yes	Yes	60	0
		42	See CA_42C Bandwidth combination set 0 in Table 5.6A.1-1						
CA_28A-42A-42A	-	28		Yes	Yes	Yes	Yes	60	0
		42	See CA_42A-42A Bandwidth combination set 0 in Table 5.6A.1-3						
CA_28A-42D	-	28		Yes	Yes			70	0
		42	See CA_42D Bandwidth combination set 0 in Table 5.6A.1-1						
CA_28A-42A-42C	CA_42C	28		Yes	Yes	Yes	Yes	80	0
		42	See CA_42A-42C Bandwidth combination set 0 in Table 5.6A.1-3						
CA_28A-42C-42C	CA_42C	28		Yes	Yes	Yes	Yes	100	0
		42	See CA_42C-42C Bandwidth combination set 0 in Table 5.6A.1-3						
CA_28A-46A	-	28		Yes	Yes	Yes	Yes	40	0
		46		Yes			Yes		
CA_28A-46C	-	28		Yes	Yes	Yes	Yes	60	0
		46	See CA_46C Bandwidth Combination set 1 in Table 5.6A.1-1						
CA_28A-46D	-	28		Yes	Yes	Yes	Yes	80	0
		46	See CA_46D Bandwidth combination set 1 in Table 5.6A.1-1						
CA_28A-46E	-	28		Yes	Yes	Yes	Yes	100	0
		46	See CA_46E Bandwidth Combination set 1 in Table 5.6A.1-1						
CA_28A-66A	-	28		Yes	Yes	Yes	Yes	40	0
		66		Yes	Yes	Yes	Yes		
CA_29A-30A	-	29		Yes	Yes			20	0
		30		Yes	Yes				
CA_29A-66A	-	29		Yes	Yes			30	0
		66		Yes	Yes	Yes	Yes		
CA_29A-66C		29		Yes	Yes			50	0
		66	See CA_66C Bandwidth Combination set 0 in Table 5.6A.1-1						
CA_29A-66A-66A		29		Yes	Yes			50	0
		66	See CA_66A-66A Bandwidth Combination set 0 in Table 5.6A.1-3						
CA_29A-70A	-	29		Yes	Yes			25	0
		70		Yes	Yes	Yes			
CA_29A-70C	-	29		Yes	Yes			35	0
		70	See CA_70C Bandwidth combination set 0 in Table 5.6A.1-1						
CA_30A-66A	CA_30A-66A	30		Yes	Yes			30	0
		66		Yes	Yes	Yes	Yes		
CA_30A-66A-66A		30		Yes	Yes			50	0
		66	See CA_66A-66A Bandwidth Combination set 0 in Table 5.6A.1-3						
CA_32A-42A	-	32		Yes	Yes	Yes	Yes	40	0
		42		Yes	Yes	Yes	Yes		
CA_32A-43A	-	32		Yes	Yes	Yes	Yes	40	0
		43		Yes	Yes	Yes	Yes		
CA_34A-39A		34		Yes	Yes	Yes		35	0
		39		Yes	Yes	Yes	Yes		
CA_34A-41A		34		Yes	Yes	Yes		35	0
		41					Yes		
CA_38A-40A	-	38			Yes		Yes	40	0
		40			Yes		Yes		
		38			Yes	Yes	Yes		

		40			Yes	Yes	Yes		
		38			Yes		Yes		
CA_38A-40A-40A	-	40	See CA_40A-40A Bandwidth Combination Set 0 in Table 5.6A.1-3					60	0
		38			Yes	Yes	Yes		
		40	See CA_40A-40A Bandwidth Combination Set 1 in Table 5.6A.1-3					60	1
CA_38A-40C	-	38			Yes		Yes		
		40	See CA_40C Bandwidth Combination Set 0 in Table 5.6A.1-1					60	0
		38			Yes	Yes	Yes		
		40	See CA_40C Bandwidth Combination Set 1 in Table 5.6A.1-1					60	1
CA_38A-40D	-	38			Yes	Yes	Yes		
		40	See CA_40D Bandwidth Combination Set 1 in Table 5.6A.1-1					80	0
CA_39A-40A	-	39		Yes	Yes	Yes	Yes		
		40		Yes	Yes	Yes	Yes		
CA_39A-40C	-	39		Yes	Yes	Yes	Yes		
		40	See CA_40C Bandwidth Combination Set 0 in the Table 5.6A.1-1					60	0
CA_39A-40D	-	39		Yes	Yes	Yes	Yes		
		40	See CA_40D Bandwidth combination set 0 in Table 5.6A.1-1					80	0
CA_39A-40E	-	39		Yes	Yes	Yes	Yes		
		40	See the CA_40E Bandwidth combination set 0 in the Table 5.6A.1-1					100	0
CA_39C-40A	-	39	See CA_39C Bandwidth combination set 0 in the Table 5.6A.1-1					55	0
		40		Yes	Yes	Yes	Yes		
CA_39C-40C	-	39	See CA_39C Bandwidth combination set 0 in Table 5.6A.1-1					75	0
		40	See CA_40C Bandwidth combination set 0 in Table 5.6A.1-1						
CA_39C-40D	-	39	See the CA_39C Bandwidth combination set 0 in the Table 5.6A.1-1					95	0
		40	See the CA_40D Bandwidth combination set 0 in the Table 5.6A.1-1						
CA_39A-41A	CA_39A-41A	39			Yes	Yes	Yes		
		41					Yes		
CA_39A-41C	CA_41C CA_39A-41A CA_39A-41C	39			Yes	Yes	Yes		
		41					Yes		
		41					Yes		
CA_39A-41D	CA_41C CA_39A-41A	39			Yes	Yes	Yes		
		41					Yes		
		41					Yes		
		41					Yes		
CA_39C-41A	CA_39C CA_39A-41A CA_39C-41A	39	See CA_39C Bandwidth Combination Set 0 in Table 5.6A.1-1					55	0
		41					Yes		
CA_39C-41C	CA_39C CA_41C CA_39A-41A	39	See CA_39C Bandwidth Combination Set 0 in Table 5.6A.1-1					75	0
		41					Yes		
		41					Yes		
CA_39C-41D	-	39	See CA_39C Bandwidth Combination Set 0 in Table 5.6A.1-1					95	0
		41	See CA_41D Bandwidth Combination Set 0 in Table 5.6A.1-1						
CA_39A-42A	-	39		Yes	Yes	Yes	Yes		
		42		Yes	Yes	Yes	Yes		
CA_39A-42C	-	39		Yes	Yes	Yes	Yes		
		42	See CA_42C Bandwidth Combination Set 1 in Table 5.6A.1-1					60	0
CA_39A-42D	-	39		Yes	Yes	Yes	Yes		

		42	See CA_42D Bandwidth combination set 1 in Table 5.6A.1-1								
CA_39A-42E	-	39	Yes	Yes	Yes	Yes			100	0	
		42	See the CA_42E Bandwidth combination set 0 in the Table 5.6A.1-1								
CA_39C-42A	-	39	See CA_39C Bandwidth Combination Set 0 in the Table 5.6A.1-1							55	0
		42	Yes	Yes	Yes	Yes					
CA_39C-42C	-	39	See CA_39C Bandwidth combination set 0 in Table 5.6A.1-1							75	0
		42	See CA_42C Bandwidth combination set 1 in Table 5.6A.1-1								
CA_39C-42D	-	39	See the CA_39C Bandwidth combination set 0 in the Table 5.6A.1-1							95	0
		42	See the CA_42D Bandwidth combination set 1 in the Table 5.6A.1-1								
CA_39A-46A	-	39	Yes	Yes	Yes	Yes			40	0	
		46						Yes			
CA_39A-46C	-	39	Yes	Yes	Yes	Yes			60	0	
		46	See CA_46C Bandwidth Combination Set 0 in Table 5.6A.1-1								
CA_39A-46D	-	39	Yes	Yes	Yes	Yes			80	0	
		46	See the CA_46D Bandwidth combination set 0 in Table 5.6A.1-1								
CA_39A-46E	-	39	Yes	Yes	Yes	Yes			100	0	
		46	See CA_46E Bandwidth Combination Set 0 in Table 5.6A.1-1								
CA_39C-46A	-	39	See CA_39C Bandwidth Combination Set 0 in Table 5.6A.1-1							55	0
		46						Yes			
CA_39C-46C	-	39	See CA_39C Bandwidth Combination Set 0 in Table 5.6A.1-1							75	0
		46	See the CA_46C Bandwidth combination set 0 in Table 5.6A.1-1								
CA_39C-46D	-	39	See CA_39C Bandwidth Combination Set 0 in Table 5.6A.1-1							95	0
		46	See CA_46D Bandwidth Combination Set 0 in Table 5.6A.1-1								
CA_40A-41A	-	40	Yes	Yes	Yes	Yes			40	0	
		41	Yes	Yes	Yes	Yes					
CA_40A-42A	CA_40A-42A	40	Yes	Yes	Yes	Yes			40	0	
		42	Yes	Yes	Yes						
CA_40A-42C	-	40	Yes	Yes	Yes	Yes			60	0	
		42	See CA_42C Bandwidth Combination Set 0 in Table 5.6A.1-1								
CA_40C-42C	-	40	See CA_40C Bandwidth combination set 1 in Table 5.6A.1-1							80	0
		42	See CA_42C Bandwidth Combination Set 0 in Table 5.6A.1-1								
CA_40A-43A	-	40	Yes	Yes	Yes	Yes			40	0	
		43	Yes	Yes	Yes	Yes					
CA_40A-46A	-	40	Yes	Yes	Yes	Yes			40	0	
		46						Yes			
		40	Yes	Yes	Yes	Yes			40	1	
		46			Yes	Yes	Yes				
CA_40A-46C	-	40	Yes	Yes	Yes	Yes			60	0	
		46	See CA_46C Bandwidth Combination Set 0 in Table 5.6A.1-1								
		40	Yes	Yes	Yes	Yes			60	1	
CA_40A-46D	-	40	Yes	Yes	Yes	Yes			80	0	

		46	See CA_46D Bandwidth combination set 0 in Table 5.6A.1-1							
		40		Yes	Yes	Yes	Yes			
		46	See CA_46D Bandwidth combination set 1 in Table 5.6A.1-1						80	1
CA_40A-46E	-	40		Yes	Yes	Yes	Yes			
		46	See CA_46E Bandwidth combination set 0 in Table 5.6A.1-1						100	0
		40		Yes	Yes	Yes	Yes			
		46	See CA_46E Bandwidth combination set 1 in Table 5.6A.1-1						100	1
CA_40C-42A	-	40	See CA_40C Bandwidth Combination Set 1 in Table 5.6A.1-1						60	0
		42		Yes	Yes	Yes				
CA_40C-46A	-	40	See CA_40C Bandwidth Combination Set 0 in Table 5.6A.1-1						60	0
		46					Yes			
CA_40C-46C	-	40	See CA_40C Bandwidth combination set 0 in Table 5.6A.1-1						80	0
		46	See CA_46C Bandwidth Combination Set 0 in Table 5.6A.1-1							
CA_40C-46D	-	40	See CA_40C Bandwidth combination set 0 in Table 5.6A.1-1						100	0
		46	See CA_46D Bandwidth Combination Set 0 in Table 5.6A.1-1							
CA_40D-46A	-	40	See CA_40D Bandwidth combination set 0 in Table 5.6A.1-1						80	0
		46					Yes			
CA_40D-46C	-	40	See CA_40D Bandwidth combination set 0 in Table 5.6A.1-1						100	0
		46	See CA_46C Bandwidth Combination Set 0 in Table 5.6A.1-1							
CA_41A <sup>9</sup> -42A <sup>9</sup>	CA_41A-42A	41			Yes	Yes	Yes		40	0
		42			Yes	Yes	Yes			
CA_41A-42C	CA_41A-42A, CA_42C, CA_41A-42C	41			Yes	Yes	Yes		60	0
		42	See CA_42C Bandwidth Combination Set 1 in Table 5.6A.1-1							
CA_41A-42A-42A	-	41			Yes	Yes	Yes		60	0
		42	See CA_42A-42A Bandwidth combination set 1 in Table 5.6A.1-3							
CA_41A-42D	-	41			Yes	Yes	Yes		80	0
		42	See CA_42D Bandwidth combination set 1 in Table 5.6A.1-1							
CA_41A-42A-42C	CA_42C	41			Yes	Yes	Yes		80	0
		42	See CA_42A-42C Bandwidth combination set 1 in Table 5.6A.1-3							
CA_41A-42C-42C	CA_42C	41			Yes	Yes	Yes		100	0
		42	See CA_42C-42C Bandwidth combination set 1 in Table 5.6A.1-3							
CA_41C-42A	CA_41A-42A, CA_41C, CA_41C-42A	41	See CA_41C Bandwidth Combination Set 0 in Table 5.6A.1-1						60	0
		42		Yes	Yes	Yes				
CA_41C-42C	CA_41A-42A, CA_41C, CA_42C, CA_41C-42C	41	See CA_41C Bandwidth Combination Set 0 in Table 5.6A.1-1						80	0
		42	See CA_42C Bandwidth Combination Set 1 in Table 5.6A.1-1							
CA_41C-42A-42A	-	41	See CA_41C Bandwidth Combination Set 0 in Table 5.6A.1-1						80	0
		42	See CA_42A-42A Bandwidth combination set 1 in Table 5.6A.1-3							
CA_41C-42D	-	41	See CA_41C Bandwidth Combination Set 0 in Table 5.6A.1-1					100	0	

		42	See CA_42D Bandwidth Combination Set 1 in Table 5.6A.1-1						
CA_41C-42A-42C	CA_42C	41	See CA_41C Bandwidth Combination Set 0 in Table 5.6A.1-1	100	0				
		42	See CA_42A-42C Bandwidth combination set 1 in Table 5.6A.1-3						
CA_41C-42C-42C	CA_42C	41	See CA_41C Bandwidth Combination Set 0 in Table 5.6A.1-1	120	0				
		42	See CA_42C-42C Bandwidth combination set 1 in Table 5.6A.1-3						
CA_41D-42A	-	41	See CA_41D Bandwidth combination set 0 in Table 5.6A.1-1	80	0				
		42							
CA_41D-42C	-	41	See CA_41D Bandwidth Combination Set 0 in Table 5.6A.1-1	100	0				
		42	See CA_42C Bandwidth Combination Set 1 in Table 5.6A.1-1						
CA_41A-46A	-	41		Yes	Yes	Yes	Yes	40	0
		46					Yes		
CA_41A-46C	-	41		Yes	Yes	Yes	Yes	60	0
		46	See CA_46C Bandwidth combination set 0 in Table 5.6A.1-1						
CA_41A-46D	-	41		Yes	Yes	Yes	Yes	80	0
		46	See CA_46D Bandwidth combination set 0 in Table 5.6A.1-1						
CA_41A-46E	-	41		Yes	Yes	Yes	Yes	100	0
		46	See the CA_46E Bandwidth combination set 0 in Table 5.6A.1-1						
CA_41C-46A	-	41	See CA_41C Bandwidth Combination Set 2 in Table 5.6A.1-1	60	0				
		46							
CA_41C-46C	-	41	See CA_41C Bandwidth combination set 2 in Table 5.6A.1-1	80	0				
		46	See CA_46C Bandwidth combination set 0 in Table 5.6A.1-1						
CA_41C-46D	-	41	See the CA_41C Bandwidth combination set 2 in Table 5.6A.1-1	100	0				
		46	See the CA_46D Bandwidth combination set 0 in Table 5.6A.1-1						
CA_41D-46A	-	41	See CA_41D Bandwidth combination set 0 in Table 5.6A.1-1	80	0				
		46							
CA_41D-46C	-	41	See the CA_41D Bandwidth combination set 0 in Table 5.6A.1-1	100	0				
		46	See the CA_46C Bandwidth combination set 0 in Table 5.6A.1-1						
CA_41A-48A	-	41		Yes	Yes	Yes	40	0	
		48		Yes	Yes	Yes			
CA_41A-48C	-	41		Yes	Yes	Yes	60	0	
		48	See CA_48C Bandwidth combination set 0 in Table 5.6A.1-1						
CA_41A-48D	-	41		Yes	Yes	Yes	80	0	
		48	See CA_48D Bandwidth combination set 0 in Table 5.6A.1-1						
CA_41C-48A	CA_41C	41	See the CA_41C Bandwidth combination set 2 in Table 5.6A.1-1	60	0				
		48							
CA_41C-48C	CA_41C	41	See the CA_41C Bandwidth combination set 2 in Table 5.6A.1-1	80	0				
		48	See the CA_48C Bandwidth combination set 0 in Table 5.6A.1-1						
CA_41C-48D	CA_41C	41	See the CA_41C Bandwidth combination set 2 in Table 5.6A.1-1	100	0				
		48	See the CA_48D Bandwidth combination set 0 in Table 5.6A.1-1						



CA_41D-48A	CA_41C	41	See the CA_41D Bandwidth combination set 0 in Table 5.6A.1-1				80	0	
		48		Yes	Yes	Yes			Yes
CA_41D-48C	CA_41C	41	See the CA_41D Bandwidth combination set 0 in Table 5.6A.1-1				100	0	
		48	See the CA_48C Bandwidth combination set 0 in Table 5.6A.1-1						
CA_42A-43A	-	42		Yes	Yes	Yes	Yes	40	0
		43		Yes	Yes	Yes	Yes		
CA_42A-46A	-	42		Yes	Yes	Yes	Yes	40	0
		46					Yes		
CA_46A-48A	-	46					Yes	40	0
		48		Yes	Yes	Yes	Yes		
CA_46A-48A-48A	-	46					Yes	60	0
		48	See CA_48A-48A Bandwidth combination set 0 in Table 5.6A.1-3						
CA_46A-48C	CA_48C	46					Yes	60	0
		48	See CA_48C Bandwidth combination set 0 in Table 5.6A.1-1						
CA_46C-48A	-	46	See CA_46C Bandwidth combination set 0 in Table 5.6A.1-1				60	0	
		48		Yes	Yes	Yes			Yes
CA_46C-48A-48A	-	46	See CA_46C Bandwidth Combination Set 0 in Table 5.6A.1-1				80	0	
		48	See CA_48A-48A Bandwidth Combination Set 0 in Table 5.6A.1-3						
CA_46A-48B	CA_48B	46					Yes	40	0
		48	See CA_48B Bandwidth combination set 0 in 36.101 Table 5.6A.1-1						
CA_46C-48C	CA_48C	46	See CA_46C Bandwidth Combination Set 0 in Table 5.6A.1-1				80	0	
		48	See CA_48C Bandwidth Combination Set 0 in Table 5.6A.1-1						
CA_46C-48B	CA_48B	46	See CA_46C Bandwidth combination set 0 in 36.101 Table 5.6A.1-1				60	0	
		48	See CA_48B Bandwidth combination set 0 in 36.101 Table 5.6A.1-1						
CA_46A-48D	CA_48C	46					Yes	80	0
		48	See CA_48D Bandwidth Combination Set 0 in Table 5.6A.1-1						
CA_46D-48A	-	46	See CA_46D Bandwidth Combination Set 0 in Table 5.6A.1-1				80	0	
		48		Yes	Yes	Yes			Yes
CA_46D-48B	CA_48B	46	See CA_46D Bandwidth combination set 0 in 36.101 Table 5.6A.1-1				80	0	
		48	See CA_48B Bandwidth combination set 0 in 36.101 Table 5.6A.1-1						
CA_46A-46A-66A	-	46	See CA_46A-46A Bandwidth combination set 0 in Table 5.6A.1-3				60	0	
		66		Yes	Yes	Yes			Yes
CA_46A-46C-66A	-	46	See CA_46A-46C Bandwidth Combination Set 0 in Table 5.6A.1-3				80	0	
		66		Yes	Yes	Yes			Yes
CA_46A-46D-66A	-	46	See CA_46A-46D Bandwidth Combination Set 0 in Table 5.6A.1-3				100	0	
		66		Yes	Yes	Yes			Yes
CA_46A-48E	CA_48C	46					Yes	100	0
		48	See CA_48E Bandwidth combination set 0 in the Table 5.6A.1-1						
CA_46C-48D	CA_48C	46	See CA_46C Bandwidth combination set 0 in the Table 5.6A.1-1				100	0	
		48	See CA_48D Bandwidth combination set 0 in the Table 5.6A.1-1						
CA_46D-48A-48A	-	46	See CA_46D Bandwidth combination set 0 in Table 5.6A.1-1				100	0	

		48	See CA_48A-48A Bandwidth combination set 0 in Table 5.6A.1-3							
CA_46D-48C	-	46	See CA_46D Bandwidth combination set 0 in Table 5.6A.1-1	100	0					
		48	See CA_48C Bandwidth combination set 0 in Table 5.6A.1-1							
CA_46E-48A	-	46	See CA_46E Bandwidth combination set 0 in the Table 5.6A.1-1	100	0					
		48	Yes Yes Yes Yes							
CA_46E-48B	CA_48B	46	See CA_46E Bandwidth combination set 0 in 36.101 Table 5.6A.1-1	100	0					
		48	See CA_48B Bandwidth combination set 0 in 36.101 Table 5.6A.1-1							
CA_46C-66A	-	46	See CA_46C Bandwidth Combination Set 0 in Table 5.6A.1-1	60	0					
		66	Yes Yes Yes Yes							
CA_46A-66A	-	46		40	0					Yes
		66	Yes Yes Yes Yes							
CA_46A-66A-66A	-	46		60	0					Yes
		66	See the CA_66A-66A Bandwidth combination set 0 in the Table 5.6A.1-3							
CA_46C-66A-66A	-	46	See CA_46C Bandwidth Combination Set 0 in Table 5.6A.1-1	80	0					
		66	See CA_66A-66A Bandwidth Combination Set 0 in Table 5.6A.1-3							
CA_46A-66C	-	46		60	0					Yes
		66	See the CA_66C Bandwidth combination set 0 in the Table 5.6A.1-1							
CA_46D-66A	-	46	See CA_46D Bandwidth combination set 0 in Table 5.6A.1-1	80	0					Yes Yes Yes Yes
		66								
CA_46D-66A-66A	-	46	See CA_46D Bandwidth Combination Set 0 in Table 5.6A.1-1	100	0					
		66	See CA_66A-66A Bandwidth Combination Set 0 in Table 5.6A.1-3							
CA_46C-48E	CA_48C	46	See the CA_46C Bandwidth combination set 0 in Table 5.6A.1-1	120	0					
		48	See the CA_48E Bandwidth combination set 0 in Table 5.6A.1-1							
CA_46E-48C	-	46	See the CA_46E Bandwidth combination set 0 in Table 5.6A.1-1	120	0					
		48	See the CA_48C Bandwidth combination set 0 in Table 5.6A.1-1							
CA_46E-66A	-	46	See CA_46E Bandwidth combination set 0 in Table 5.6A.1-1	100	0					
		66	Yes Yes Yes Yes							
CA_46E-66A-66A	-	46	See CA_46E Bandwidth Combination Set 0 in Table 5.6A.1-1	120	0					
		66	See CA_66A-66A Bandwidth Combination Set 0 in Table 5.6A.1-3							
CA_46A-70A	-	46		35	0					Yes
		70	Yes Yes Yes Yes							
CA_46A-71A	-	46		40	0					Yes
		71	Yes Yes Yes Yes							
CA_46C-71A	-	46	See CA_46C Bandwidth combination set 0 in Table 5.6A.1-1	60	0					
		71	Yes Yes Yes Yes							
CA_46D-71A	-	46	See CA_46D Bandwidth combination set 0 in Table 5.6A.1-1	80	0					
		71	Yes Yes Yes Yes							
CA_48A-66A	-	48		40	0					Yes Yes Yes Yes
		66	Yes Yes Yes Yes							
CA_48A-48A-66A	-	48	See CA_48A-48A Bandwidth combination set 0 in Table 5.6A.1-3	60	0					
		66	Yes Yes Yes Yes							

CA_48A-48C-66A	-	48	See the CA_48A-48C Bandwidth combination set 0 in the Table 5.6A.1-3				80	0	
		66		Yes	Yes	Yes			Yes
CA_48A-48C-66B	-	48	See CA_48A-48C Bandwidth combination set 0 in the Table 5.6A.1-3				80	0	
		66	See CA_66B Bandwidth combination set 0 in the Table 5.6A.1-1						
CA_48A-48C-66C	-	48	See CA_48A-48C Bandwidth combination set 0 in the Table 5.6A.1-3				100	0	
		66	See CA_66C Bandwidth combination set 0 in the Table 5.6A.1-1						
CA_48A-48D-66A	-	48	See CA_48A-48D Bandwidth combination set 0 in the Table 5.6A.1-3				100	0	
		66		Yes	Yes	Yes			Yes
CA_48C-48C-66A	-	48	See CA_48C-48C Bandwidth combination set 0 in the Table 5.6A.1-3				100	0	
		66		Yes	Yes	Yes			Yes
CA_48A-66A-66A	-	48		Yes	Yes	Yes	Yes	60	0
		66	See CA_66A-66A Bandwidth Combination Set 0 in Table 5.6A.1-3						
CA_48A-48A-66A-66A	-	48	See CA_48A-48A Bandwidth combination set 0 in the Table 5.6A.1-3				80	0	
		66	See CA_66A-66A Bandwidth Combination Set 0 in Table 5.6A.1-3						
CA_48A-48A-66B	-	48	See CA_48A-48A Bandwidth combination set 0 in the Table 5.6A.1-3				60	0	
		66	See CA_66B Bandwidth combination set 0 in Table 5.6A.1-1						
CA_48A-48A-66C	-	48	See CA_48A-48A Bandwidth combination set 0 in the Table 5.6A.1-3				80	0	
		66	See CA_66C Bandwidth Combination Set 0 in Table 5.6A.1-1						
CA_48C-66A-66A	-	48	See CA_48C Bandwidth combination set 0 in the Table 5.6A.1-1				80	0	
		66	See CA_66A-66A Bandwidth combination set 0 in Table 5.6A.1-3						
CA_48C-66B	-	48	See CA_48C Bandwidth combination set 0 in the Table 5.6A.1-1				60	0	
		66	See CA_66B Bandwidth combination set 0 in Table 5.6A.1-1						
CA_48C-66C	-	48	See CA_48C Bandwidth combination set 0 in the Table 5.6A.1-1				80	0	
		66	See CA_66C Bandwidth Combination Set 0 in Table 5.6A.1-1						
CA_48A-66B	-	48		Yes	Yes	Yes	Yes	40	0
		66	See CA_66B Bandwidth Combination Set 0 in Table 5.6A.1-1						
CA_48A-66C	-	48		Yes	Yes	Yes	Yes	60	0
		66	See CA_66C Bandwidth Combination Set 0 in Table 5.6A.1-1						
CA_48C-66A	-	48	See CA_48C Bandwidth combination set 0 in Table 5.6A.1-1				60	0	
		66		Yes	Yes	Yes			Yes
CA_48D-66A	-	48	See the CA_48D Bandwidth combination set 0 in the Table 5.6A.1-1				80	0	
		66		Yes	Yes	Yes			Yes
CA_48E-66A	-	48	See CA_48E Bandwidth combination set 0 in the Table 5.6A.1-1				100	0	
		66		Yes	Yes	Yes			Yes
CA_48A-71A	-	48		Yes	Yes	Yes	Yes	40	0
		71		Yes	Yes	Yes	Yes		
CA_48C-71A	-	48	See CA_48C Bandwidth combination set 0 in Table 5.6A.1-1				60	0	
		71		Yes	Yes	Yes			Yes
CA_48A-48A-71A	-	48	See CA_48A-48A Bandwidth combination set 0 in Table 5.6A.1-3				60	0	

		71			Yes	Yes	Yes	Yes		
CA_66A-70A	-	66			Yes	Yes	Yes	Yes	35	0
		70			Yes	Yes	Yes	Yes		
CA_66A-66A-70A	-	66	See CA_66A-66A Bandwidth combination set 0 in Table 5.6A.1-3						55	0
		70			Yes	Yes	Yes	Yes		
CA_66A-70C	-	66			Yes	Yes	Yes	Yes	45	0
		70	See CA_70C Bandwidth combination set 0 in Table 5.6A.1-1							
CA_66A-66A-70C	-	66	See the CA_66A-66A Bandwidth combination set 0 in Table 5.6A.1-3						65	0
		70	See the CA_70C Bandwidth combination set 0 in Table 5.6A.1-1							
CA_66C-70A	-	66	See CA_66C Bandwidth combination set 0 in Table 5.6A.1-1						55	0
		70			Yes	Yes	Yes	Yes		
CA_66C-70C	-	66	See the CA_66C Bandwidth combination set 0 in Table 5.6A.1-1						65	0
		70	See the CA_70C Bandwidth combination set 0 in Table 5.6A.1-1							
CA_66A-71A	-	66			Yes	Yes	Yes	Yes	40	0
		71			Yes	Yes	Yes	Yes		
CA_66C-71A	-	66	See CA_66C Bandwidth Combination Set 0 in Table 5.6A.1-1						60	0
		71			Yes	Yes	Yes	Yes		
CA_66A-66A-71A	-	66	See CA_66A-66A Bandwidth Combination Set 0 in Table 5.6A.1-3						60	0
		71			Yes	Yes	Yes	Yes		
CA_70A-71A	-	70			Yes	Yes	Yes	Yes	35	0
		71			Yes	Yes	Yes	Yes		
CA_70C-71A	-	70	See the CA_70C Bandwidth combination set 0 in Table 5.6A.1-1						45	0
		71			Yes	Yes	Yes	Yes		
NOTE 1: The CA Configuration refers to a combination of an operating band and a CA bandwidth class specified in Table 5.6A-1 (the indexing letter). Absence of a CA bandwidth class for an operating band implies support of all classes.										
NOTE 2: For each band combination, all combinations of indicated bandwidths belong to the set.										
NOTE 3: For the supported CC bandwidth combinations, the CC downlink and uplink bandwidths are equal.										
NOTE 4: Uplink CA configurations are the configurations supported by the present release of specifications.										
NOTE 5: For TDD inter-band Carrier Aggregation only non-simultaneous Rx/Tx uplink CA configurations can be supported by UE supporting corresponding DL CA configuration without simultaneous Rx/Tx.										
NOTE 6: Void										
NOTE 7: Power imbalance between downlink carriers on Band 20 and Band 28 is assumed to be within [6dB].										
NOTE 8: For the corresponding CA configuration, UE may not support Pcell transmissions in this E-UTRA band.										
NOTE 9: 8Rx Requirements are applicable for this band configuration if UE supports 8Rx.										

**Table 5.6A.1-2a: E-UTRA CA configurations and bandwidth combination sets defined for inter-band CA (three bands)**

E-UTRA CA configuration / Bandwidth combination set										
E-UTRA CA Configuration	Uplink CA configurations (NOTE 5)	E-UTRA Bands	1.4 MHz	3 MHz	5 MHz	10 MHz	15 MHz	20 MHz	Maximum aggregated bandwidth [MHz]	Bandwidth combination set
CA_1A-3A-5A	CA_1A-3A CA_1A-5A <sup>6</sup> CA_3A-5A	1			Yes	Yes	Yes	Yes	50	0
		3			Yes	Yes	Yes	Yes		
		5			Yes	Yes				
		1			Yes	Yes			40	1
		3			Yes	Yes	Yes	Yes		
5			Yes	Yes						
CA_1A-1A-3A-5A	-	1	See CA_1A-1A Bandwidth Combination Set 0 in Table 5.6A.1-3						70	0
		3			Yes	Yes	Yes	Yes		
		5			Yes	Yes				
CA_1A-1A-3C-5A	CA_1A-3A, CA_1A-5A CA_3A-5A	1	See CA_1A-1A Bandwidth Combination Set 0 in Table 5.6A.1-3						90	0
		3	See CA_3C Bandwidth combination set 0 in table 5.6A.1-1							
		5			Yes	Yes				
CA_1A-3A-3A-5A	-	1			Yes	Yes	Yes		65	0
		3	See CA_3A-3A Bandwidth Combination Set 0 in Table 5.6A.1-3							
		5			Yes	Yes				
CA_1C-3A-5A	-	1	See CA_1C Bandwidth combination set 0 in Table 5.6A.1-1						70	0
		3			Yes	Yes	Yes	Yes		
		5			Yes	Yes				
CA_1A-3A-3A-7A-7A	CA_1A-3A, CA_1A-7A, CA_3A-7A	1			Yes	Yes	Yes	Yes	100	0
		3	See the CA_3A-3A Bandwidth combination set 0 in Table below							
		7	See the CA_7A-7A Bandwidth combination set 1 in Table below							
CA_1A-3C-5A	-	1			Yes	Yes	Yes	Yes	70	0
		3	See CA_3C Bandwidth combination set 0 in Table 5.6A.1-1							
		5			Yes	Yes				
CA_1A-3A-7A	CA_1A-3A CA_1A-7A CA_3A-7A	1			Yes	Yes	Yes	Yes	60	0
		3			Yes	Yes	Yes	Yes		
		7			Yes	Yes	Yes	Yes		
		1			Yes	Yes	Yes	Yes	60	1
		3			Yes	Yes	Yes	Yes		
		7			Yes	Yes	Yes	Yes		
CA_1A-1A-3A-7A	-	1	See CA_1A-1A Bandwidth Combination Set 0 in Table 5.6A.1-3						80	0
		3			Yes	Yes	Yes	Yes		
		7			Yes	Yes	Yes	Yes		
CA_1A-1A-3C-7A	-	1	See the CA_1A-1A Bandwidth combination set 0 in the Table 5.6A.1-3						100	0
		3	See CA_3C Bandwidth Combination Set 0 in Table 5.6A.1-1							
		7			Yes	Yes	Yes	Yes		
CA_1A-1A-3A-3A-7A	CA_1A-3A CA_1A-7A CA_3A-7A	1	See the CA_1A-1A Bandwidth combination set 0 in the Table 5.6A.1-3						100	0
		3	See the CA_3A-3A Bandwidth combination set 0 in the Table 5.6A.1-3							
		7			Yes	Yes	Yes	Yes		
CA_1A-3A-3A-7A	CA_1A-3A, CA_1A-7A, CA_3A-7A	1			Yes	Yes	Yes	Yes	80	0
		3	See the CA_3A-3A Bandwidth combination set 0 in the Table 5.6A.1-3							
		7			Yes	Yes	Yes	Yes		
CA_1A-1A-3A-3A-7C	CA_7C	1	See CA_1A-1A Bandwidth Combination Set 0 in Table 5.6A.1-3						120	0
		3	See CA_3A-3A Bandwidth Combination Set 0 in Table 5.6A.1-3							

		7	See CA_7C Bandwidth combination set 2 in Table 5.6A.1-1 of 36.101								
CA_1A-3A-3A-7C	7C	1	Yes	Yes	Yes	Yes		100	0		
		3	See CA_3A-3A Bandwidth Combination Set 0 in Table 5.6A.1-3								
		7	See CA_7C Bandwidth combination set 2 in Table 5.6A.1-1								
CA_1A-3A-7A-7A	CA_1A-3A CA_1A-7A CA_3A-7A	1	Yes	Yes	Yes	Yes		80	0		
		3	Yes	Yes	Yes	Yes					
		7	See CA_7A-7A Bandwidth Combination Set 3 in Table 5.6A.1-3							80	1
		1	Yes	Yes	Yes	Yes					
		3	Yes	Yes	Yes	Yes					
		7	See CA_7A-7A Bandwidth Combination Set 1 in Table 5.6A.1-3								
CA_1A-3A-7C	CA_1A-3A, CA_1A-7A, CA_3A-7A, CA_7C	1	Yes	Yes	Yes	Yes		80	0		
		3	Yes	Yes	Yes	Yes					
		7	See CA_7C Bandwidth Combination Set 2 in Table 5.6A.1-1							80	1
		1	Yes	Yes	Yes	Yes					
		3	Yes	Yes	Yes	Yes					
		7	See CA_7C Bandwidth Combination Set 1 in Table 5.6A.1-1								
CA_1A-1A-3A-7C	CA_7C	1	See CA_1A-1A Bandwidth Combination Set 0 in Table 5.6A.1-3							100	0
		3	Yes	Yes	Yes	Yes					
		7	See CA_7C Bandwidth combination set 2 in Table 5.6A.1-1 of 36.101								
CA_1A-1A-3C-7A	CA_3C	1	See CA_1A-1A Bandwidth Combination Set 0 in Table 5.6A.1-3							100	0
		3	See CA_3C Bandwidth combination set 0 in Table 5.6A.1-1 of 36.101								
		7	Yes	Yes	Yes	Yes					
CA_1A-1A-3C-7C	CA_3C CA_7C	1	See CA_1A-1A Bandwidth Combination Set 0 in Table 5.6A.1-3							120	0
		3	See CA_3C Bandwidth combination set 0 in Table 5.6A.1-1 of 36.101								
		7	See CA_7C Bandwidth combination set 2 in Table 5.6A.1-1 of 36.101								
CA_1A-3C-7A	CA_1A-3A, CA_1A-7A, CA_3A-7A, CA_3C	1	Yes	Yes	Yes	Yes		80	0		
		3	See CA_3C Bandwidth Combination Set 0 in Table 5.6A.1-1								
		7	Yes	Yes	Yes	Yes					
		3	See CA_3C Bandwidth Combination Set 0 in Table 5.6A.1-1							80	1
		7	Yes	Yes	Yes	Yes					
CA_1A-3C-7C	CA_1A-3A, CA_1A-7A, CA_3A-7A, CA_3C, CA_7C	1	Yes	Yes	Yes	Yes		100	0		
		3	See CA_3C Bandwidth Combination Set 0 in Table 5.6A.1-1								
		7	See CA_7C Bandwidth Combination Set 1 in Table 5.6A.1-1								
CA_1A-3A-8A	CA_1A-3A CA_1A-8A CA_3A-8A	1	Yes	Yes	Yes	Yes		50	0		
		3	Yes	Yes	Yes	Yes					
		8	Yes	Yes	Yes						
		1	Yes	Yes				40	1		
		3	Yes	Yes	Yes	Yes					
		8	Yes	Yes	Yes						
		1	Yes	Yes	Yes			40	2		
		3	Yes	Yes	Yes						
		8	Yes	Yes	Yes						
		1	Yes	Yes	Yes	Yes		50	3		
3	Yes	Yes	Yes	Yes							
8	Yes	Yes									
		1	Yes	Yes	Yes	Yes		70	0		

CA_1A-3A-3A-8A	CA_1A-3A CA_1A-8A CA_3A-8A	3	See CA_3A-3A Bandwidth Combination Set 0 in Table 5.6A.1-3				70	0	
		8		Yes	Yes	Yes			Yes
CA_1A-3C-8A	CA_1A-3A CA_1A-8A CA_3A-8A CA_3C	1		Yes	Yes	Yes	Yes		
		3	See CA_3C Bandwidth Combination Set 0 in Table 5.6A.1-1						
		8		Yes	Yes	Yes	Yes		
CA_1A-3A-3A-42C	CA_1A-3A, CA_1A-42A, CA_3A-42A	1		Yes	Yes	Yes	Yes		
		3	See CA_3A-3A Bandwidth Combination Set 0 in Table 5.6A.1-3						
CA_1A-3A-11A	-	42	See CA_42C Bandwidth Combination Set 0 in Table 5.6A.1-1				50	0	
		1		Yes	Yes	Yes			Yes
CA_1A-3A-18A	CA_1A-3A, CA_1A-18A <sup>6</sup> , CA_3A-18A	3		Yes	Yes	Yes	Yes		
		11		Yes	Yes	Yes	Yes		
		18		Yes	Yes	Yes	Yes		
CA_1A-3A-19A	CA_1A-3A CA_1A-19A <sup>6</sup> CA_3A-19A	1		Yes	Yes	Yes	Yes		
		3		Yes	Yes	Yes	Yes		
		19		Yes	Yes	Yes	Yes		
CA_1A-3A-3A-19A	CA_1A-3A CA_1A-19A <sup>6</sup> CA_3A-19A	1		Yes	Yes	Yes	Yes		
		3	See CA_3A-3A Bandwidth Combination Set 0 in Table 5.6A.1-3				75	0	
CA_1A-3A-26A	CA_1A-3A, CA_1A-26A, CA_3A-26A	19		Yes	Yes	Yes			Yes
		1		Yes	Yes	Yes	Yes		
		3		Yes	Yes	Yes	Yes		
		26		Yes	Yes	Yes	Yes		
		1		Yes	Yes	Yes	Yes		
CA_1A-3A-20A	CA_1A-3A, CA_3A-20A, CA_1A-20A	3		Yes	Yes	Yes	Yes		
		1		Yes	Yes	Yes	Yes		
		20		Yes	Yes	Yes	Yes		
CA_1A-3A-3A-20A	-	1		Yes	Yes	Yes	Yes		
		3	See CA_3A-3A Bandwidth combination set 0 in Table 5.6A.1-3				80	0	
CA_1A-3C-20A	-	20		Yes	Yes	Yes			Yes
		1		Yes	Yes	Yes	Yes		
CA_1A-3A-21A	CA_1A-3A, CA_1A-21A, CA_3A-21A	3	See CA_3C Bandwidth combination set 0 in Table 5.6A.1-1				80	0	
		20		Yes	Yes	Yes			Yes
		1		Yes	Yes	Yes			Yes
CA_1A-3A-3A-21A	CA_1A-3A, CA_1A-21A, CA_3A-21A	1		Yes	Yes	Yes	Yes		
		3	See CA_3A-3A Bandwidth Combination Set 0 in Table 5.6A.1-3				75	0	
		21		Yes	Yes	Yes			Yes
CA_1A-3A-28A	CA_1A-3A, CA_1A-28A, CA_3A-28A <sup>6</sup>	1		Yes	Yes	Yes			Yes
		3		Yes	Yes	Yes	Yes		
		28		Yes	Yes	Yes	Yes		
CA_1A-1A-3A-28A	-	1	See CA_1A-1A Bandwidth Combination Set 0 in Table 5.6A.1-3				80	0	
		3		Yes	Yes	Yes			Yes
CA_1A-1A-3A-28A	-	28		Yes	Yes	Yes	Yes		
		1	See CA_1A-1A Bandwidth Combination Set 0 in Table 5.6A.1-3				100	0	
		3	See CA_3A-3A Bandwidth Combination Set 0 in Table 5.6A.1-3						
28		Yes	Yes	Yes	Yes				
CA_1A-1A-3C-28A	CA_3C	1	See CA_1A-1A Bandwidth Combination Set 0 in Table 5.6A.1-3				100	0	
		3	See CA_3C Bandwidth combination set 0 in Table 5.6A.1-1 of 36.101						
		28		Yes	Yes	Yes			Yes



CA_1A-3A-3A-28A	-	1		Yes	Yes	Yes	Yes	80	0
		3	See CA_3A-3A Bandwidth combination set 0 in Table 5.6A.1-3						
		28		Yes	Yes	Yes	Yes		
CA_1A-3C-28A	CA_3C	1		Yes	Yes	Yes	Yes	80	0
		3	See CA_3C Bandwidth combination set 0 in Table 5.6A.1-1						
		28		Yes	Yes	Yes	Yes		
CA_1A-1A-3C-28A	CA_1A-3A, CA_1A-28A CA_3A-28A	1	See CA_1A-1A Bandwidth Combination Set 0 in Table 5.6A.1-3				100	0	
		3	See CA_3C Bandwidth combination set 0 in Table 5.6A.1-1						
		28		Yes	Yes	Yes			Yes
CA_1A-3A-32A	-	1		Yes	Yes	Yes	Yes	60	0
		3		Yes	Yes	Yes	Yes		
		32		Yes	Yes	Yes	Yes		
CA_1A-3A-38A	CA_1A-3A	1		Yes	Yes	Yes	Yes	60	0
		3		Yes	Yes	Yes	Yes		
		38		Yes	Yes	Yes	Yes		
CA_1A-3C-38A	-	1		Yes	Yes	Yes	Yes	80	0
		3	See CA_3C Bandwidth combination set 0 in Table 5.6A.1-1						
		38		Yes	Yes	Yes	Yes		
CA_1A-3A-40A	CA_1A-3A	1		Yes	Yes	Yes	Yes	60	0
		3		Yes	Yes	Yes	Yes		
		40		Yes	Yes	Yes	Yes		
CA_1A-3A-40C	-	1		Yes	Yes	Yes	Yes	80	0
		3		Yes	Yes	Yes	Yes		
		40	See CA_40C Bandwidth Combination Set 1 in Table 5.6A.1-1						
CA_1A-3C-40A	-	1		Yes	Yes	Yes	Yes	80	0
		3	See CA_3C Bandwidth Combination Set 0 in Table 5.6A.1-1						
		40		Yes	Yes	Yes	Yes		
CA_1A-3C-40C	-	1		Yes	Yes	Yes	Yes	100	0
		3	See CA_3C Bandwidth combination set 0 in Table 5.6A.1-1						
		40	See CA_40C Bandwidth combination set 1 in Table 5.6A.1-1						
CA_1A-3A-41A <sup>9</sup>	CA_1A-3A	1		Yes	Yes	Yes	Yes	60	0
		3		Yes	Yes	Yes	Yes		
		41		Yes	Yes	Yes	Yes		
CA_1A-3A-41C <sup>9</sup>	CA_1A-3A	1		Yes	Yes	Yes	Yes	80	0
		3		Yes	Yes	Yes	Yes		
		41	See CA_41C Bandwidth Combination Set 0 in Table 5.6A.1-1						
CA_1A-3A-41D <sup>9</sup>	CA_1A-3A	1		Yes	Yes	Yes	Yes	100	0
		3		Yes	Yes	Yes	Yes		
		41	See CA_41D Bandwidth Combination Set 0 in Table 5.6A.1-1						
CA_1A-3A-42A	CA_1A-3A, CA_1A-42A, CA_3A-42A	1		Yes	Yes	Yes	Yes	60	0
		3		Yes	Yes	Yes	Yes		
		42		Yes	Yes	Yes	Yes		
CA_1A-3A-3A-42A	CA_1A-3A, CA_1A-42A, CA_3A-42A	1		Yes	Yes	Yes	Yes	80	0
		3	See CA_3A-3A Bandwidth Combination Set 0 in Table 5.6A.1-3						
		42		Yes	Yes	Yes	Yes		
CA_1A-3A-42A-42A	-	1		Yes	Yes	Yes	Yes	80	0
		3		Yes	Yes	Yes	Yes		
		42	See CA_42A-42A Bandwidth Combination Set 0 in Table 5.6A.1-3						
CA_1A-3A-42A-42C	-	1		Yes	Yes	Yes	Yes	100	0
		3		Yes	Yes	Yes	Yes		
		42	See CA_42A-42C Bandwidth Combination Set 0 in Table 5.6A.1-3						
		1		Yes	Yes	Yes	Yes	80	0

CA_1A-3A-42C	CA_1A-3A, CA_1A-42A, CA_1A-42C, CA_3A-42A, CA_3A-42C, CA_42C	3		Yes	Yes	Yes	Yes			
		42	See CA_42C Bandwidth combination set 0 in Table 5.6A.1-1							
CA_1A-3A-42C-42C	-	1		Yes	Yes	Yes	Yes			
		3		Yes	Yes	Yes	Yes			
		42	See CA_42C-42C Bandwidth Combination Set 0 in Table 5.6A.1-3				120	0		
CA_1A-3A-42D	CA_1A-3A, CA_1A-42A, CA_3A-42A, CA_1A-42C, CA_3A-42C	1		Yes	Yes	Yes	Yes			
		3		Yes	Yes	Yes	Yes			
		42	See CA_42D Bandwidth combination set 0 in Table 5.6A.1-1				100	0		
CA_1A-3A-43A	-	1		Yes	Yes	Yes				
		3		Yes	Yes	Yes				
		43		Yes	Yes	Yes	Yes			
CA_1A-3A-46A	-	1		Yes	Yes	Yes	Yes			
		3		Yes	Yes	Yes	Yes			
		46		Yes			Yes			
	-	1		Yes	Yes	Yes	Yes			
		3		Yes	Yes	Yes	Yes			
		46					Yes			
CA_1A-3A-46C	-	1		Yes	Yes	Yes	Yes			
		3		Yes	Yes	Yes	Yes			
		46	See CA_46C Bandwidth Combination Set 1 in Table 5.6A.1-1				80	0		
	-	1		Yes	Yes	Yes	Yes			
		3		Yes	Yes	Yes	Yes			
46	See CA_46C in Table 5.6A.1-1 of TS 36.101 Bandwidth Combination Set 0				80	1				
CA_1A-3A-46D	-	1		Yes	Yes	Yes	Yes			
		3		Yes	Yes	Yes	Yes			
		46	See CA_46D in Table 5.6A.1-1 of TS 36.101 Bandwidth Combination Set 0				100	0		
CA_1A-3A-46E	-	1		Yes	Yes	Yes	Yes			
		3		Yes	Yes	Yes	Yes			
		46	See CA_46E in Table 5.6A.1-1 of TS 36.101 Bandwidth Combination Set 0				120	0		
CA_1A-5A-40A	CA_1A-5A <sup>6</sup>	1		Yes	Yes	Yes	Yes			
		5		Yes	Yes					
		40			Yes	Yes	Yes			
CA_1A-5A-41A <sup>11</sup>	-	1		Yes	Yes	Yes	Yes			
		5		Yes	Yes					
		41					Yes			
CA_1A-5A-46A	CA_1A-5A <sup>6</sup>	1		Yes	Yes	Yes	Yes			
		5		Yes	Yes					
		46					Yes			
CA_1A-5A-7A	CA_1A-5A <sup>6</sup> CA_1A-7A CA_5A-7A	1		Yes	Yes					
		5		Yes	Yes					
		7			Yes	Yes	Yes			
		1		Yes	Yes	Yes	Yes			
		5		Yes	Yes					
CA_1A-5A-7A-7A	CA_1A-5A <sup>6</sup> CA_1A-7A CA_5A-7A	7			Yes	Yes	Yes			
		1		Yes	Yes	Yes	Yes			
		5		Yes	Yes					
CA_1A-5A-28A	-	7	See CA_7A-7A Bandwidth Combination Set 3 in Table 5.6A.1-3				70	0		
		1		Yes	Yes	Yes				
		5		Yes	Yes					
CA_1A-5A-46C	CA_1A-5A <sup>6</sup>	1		Yes	Yes	Yes	Yes			
		5		Yes	Yes					
		46	See CA_46C Bandwidth combination set 0 in Table 5.6A.1-1				70	0		

CA_1A-5A-46D		1		Yes	Yes	Yes	Yes	90	0
		5		Yes	Yes				
		46	See CA_46D Bandwidth combination set 0 in Table 5.6A.1-1						
CA_1A-7A-8A	CA_1A-7A, CA_1A-8A CA_7A-8A	1		Yes	Yes	Yes	Yes	50	0
		7			Yes	Yes	Yes		
		8		Yes	Yes				
		1		Yes	Yes	Yes	Yes	50	1
		7		Yes	Yes	Yes	Yes		
8		Yes	Yes						
CA_1A-7A-7A-8A	CA_1A-7A CA_1A-8A CA_7A-8A	1		Yes	Yes	Yes	Yes	70	0
		7	See CA_7A-7A Bandwidth combination set 1 in Table 5.6A.1-3						
		8		Yes	Yes				
CA_1A-7A-20A	CA_1A-7A CA_1A-20A CA_7A-20A	1		Yes	Yes	Yes	Yes	50	0
		7			Yes	Yes	Yes		
		20		Yes	Yes				
		1		Yes	Yes	Yes	Yes	60	1
		7			Yes	Yes	Yes		
		1		Yes	Yes	Yes	Yes	60	2
		7		Yes	Yes	Yes	Yes		
20		Yes	Yes	Yes	Yes				
CA_1A-7A-7A-20A		1		Yes	Yes	Yes	Yes	80	0
		7	See CA_7A-7A Bandwidth Combination Set 3 in Table 5.6A.1-3						
		20		Yes	Yes	Yes	Yes		
CA_1A-7C-20A		1		Yes	Yes	Yes	Yes	80	0
		7	See CA_7C Bandwidth combination set 1 in Table 5.6A.1-1						
		20		Yes	Yes	Yes	Yes		
CA_1A-7A-26A	CA_1A-7A CA_1A-26A, CA_7A-26A	1		Yes	Yes	Yes	Yes	55	0
		7		Yes	Yes	Yes	Yes		
		26		Yes	Yes	Yes	Yes		
CA_1A-7A-7A-26A	CA_1A-7A CA_1A-26A, CA_7A-26A	1		Yes	Yes	Yes	Yes	75	0
		7	See CA_7A-7A Bandwidth Combination Set 3 in Table 5.6A.1-3						
		26		Yes	Yes	Yes	Yes		
CA_1A-7A-28A	CA_1A-7A, CA_1A-28A, CA_7A-28A	1		Yes	Yes	Yes	Yes	55	0
		7			Yes	Yes	Yes		
		28		Yes	Yes	Yes	Yes		
		1		Yes	Yes	Yes	Yes	60	1
		7			Yes	Yes	Yes		
		1		Yes	Yes	Yes	Yes	60	2
		7			Yes	Yes	Yes		
28		Yes	Yes	Yes	Yes				
CA_1A-1A-7A-28A		1	See CA_1A-1A Bandwidth Combination Set 0 in Table 5.6A.1-3				80	0	
		7		Yes	Yes	Yes			Yes
		28		Yes	Yes	Yes			Yes
CA_1A-1A-7C-28A	CA_7C	1	See CA_1A-1A Bandwidth Combination Set 0 in Table 5.6A.1-3				100	0	
		7	See CA_7C Bandwidth combination set 2 in Table 5.6A.1-1						
		28		Yes	Yes	Yes			Yes
CA_1A-7A-7A-28A		1		Yes	Yes	Yes	Yes	80	0
		7	See CA_7A-7A Bandwidth combination set 3 in Table 5.6A.1-3						
		28		Yes	Yes	Yes	Yes		
CA_1A-7C-28A	CA_1A-7A, CA_1A-28A, CA_7A-28A, CA_7C	1		Yes	Yes	Yes	Yes	80	0
		7	See CA_7C Bandwidth Combination Set 2 in Table 5.6A.1-1						
		28		Yes	Yes	Yes	Yes		
CA_1A-7A-32A		1		Yes	Yes	Yes	Yes	60	0
		7		Yes	Yes	Yes	Yes		

		32			Yes	Yes	Yes	Yes		
CA_1A-7A-38A <sup>16</sup>	-	1			Yes	Yes	Yes	Yes	60	0
		7			Yes	Yes	Yes	Yes		
		38			Yes	Yes	Yes	Yes		
CA_1A-7A-40A	-	1			Yes	Yes	Yes	Yes	60	0
		7			Yes	Yes	Yes	Yes		
		40			Yes	Yes	Yes	Yes		
CA_1A-7A-40C	-	1			Yes	Yes	Yes	Yes	80	0
		7			Yes	Yes	Yes	Yes		
		40		See CA_40C Bandwidth combination set 1 in Table 5.6A.1-1						
CA_1A-7A-42A	-	1			Yes	Yes	Yes	Yes	60	0
		7			Yes	Yes	Yes	Yes		
		42			Yes	Yes	Yes	Yes		
CA_1A-7A-46A	CA_1A-7A	1			Yes	Yes	Yes	Yes	60	0
		7			Yes	Yes	Yes	Yes		
		46						Yes		
CA_1A-7A-46A	-	1			Yes	Yes	Yes	Yes	60	1
		7			Yes	Yes	Yes	Yes		
		46						Yes		
CA_1A-7A-46C	CA_1A-7A	1			Yes	Yes	Yes	Yes	80	0
		7			Yes	Yes	Yes	Yes		
		46		See CA_46C Bandwidth combination set 0 in Table 5.6A.1-1						
CA_1A-7A-46C	-	1			Yes	Yes	Yes	Yes	80	1
		7			Yes	Yes	Yes	Yes		
		46		See CA_46C in Table 5.6A.1-1 of TS 36.101 Bandwidth Combination Set 0						
CA_1A-7A-46D	-	1			Yes	Yes	Yes	Yes	100	0
		7			Yes	Yes	Yes	Yes		
		46		See CA_46D Bandwidth Combination Set 0 in Table 5.6A.1-1						
CA_1A-7A-46D	-	1			Yes	Yes	Yes	Yes	100	1
		7			Yes	Yes	Yes	Yes		
		46		See CA_46D in Table 5.6A.1-1 of TS 36.101 Bandwidth Combination Set 0						
CA_1A-7A-46E	-	1			Yes	Yes	Yes	Yes	120	0
		7			Yes	Yes	Yes	Yes		
		46		See CA_46E in Table 5.6A.1-1 of TS 36.101 Bandwidth Combination Set 0						
CA_1A-8A-11A	-	1			Yes	Yes	Yes	Yes	40	0
		8			Yes	Yes				
		11			Yes	Yes				
CA_1A-8A-20A	-	1			Yes	Yes	Yes	Yes	50	0
		8			Yes	Yes				
		20			Yes	Yes	Yes	Yes		
CA_1A-8A-28A	-	1			Yes	Yes	Yes	Yes	50	0
		8		Yes	Yes	Yes				
		28			Yes	Yes	Yes	Yes		
CA_1A-8A-38A	-	1			Yes	Yes	Yes	Yes	50	0
		8			Yes	Yes				
		38			Yes	Yes	Yes	Yes		
CA_1A-8A-40A	CA_1A-8A	1			Yes	Yes	Yes	Yes	50	0
		8		Yes	Yes	Yes				
		40			Yes	Yes	Yes	Yes		
CA_1A-8A-40C	-	1			Yes	Yes	Yes	Yes	70	0
		8			Yes	Yes				
		40		See CA_40C Bandwidth combination set 1 in Table 5.6A.1-1						
CA_1A-8A-42A	-	1			Yes	Yes	Yes	Yes	50	0
		8			Yes	Yes				
		42			Yes	Yes	Yes	Yes		
CA_1A-8A-42C	-	1			Yes	Yes	Yes	Yes	70	0
		8			Yes	Yes				

		42	See CA_42C Bandwidth Combination Set 0 in Table 5.6A.1-1						
CA_1A-11A-18A	-	1		Yes	Yes	Yes	Yes	45	0
		11		Yes	Yes				
		18		Yes	Yes	Yes	Yes		
CA_1A-11A-28A	-	1		Yes	Yes	Yes	Yes	50	0
		11		Yes	Yes				
		28		Yes	Yes	Yes	Yes		
CA_1A-11A-42A	-	1		Yes	Yes	Yes	Yes	50	0
		11		Yes	Yes				
		42		Yes	Yes	Yes	Yes		
CA_1A-11A-42C	-	1		Yes	Yes	Yes	Yes	70	0
		11		Yes	Yes				
		42	See CA_42C Bandwidth Combination Set 0 in Table 5.6A.1-1						
CA_1A-18A-28A	CA_1A-18A <sup>6</sup> CA_1A-28A CA_18A-28A	1		Yes	Yes	Yes	Yes	45	0
		18		Yes	Yes	Yes			
		28		Yes	Yes				
		1		Yes	Yes	Yes	Yes	40	1
		18		Yes	Yes				
28		Yes	Yes						
CA_1A-18A-41A	CA_1A-18A CA_1A-41A CA_18A-41A	1		Yes	Yes	Yes	Yes	55	0
		18		Yes	Yes	Yes			
		41		Yes	Yes	Yes	Yes		
CA_1A-18A-41C	CA_1A-18A CA_1A-41A CA_1A-41C CA_18A-41A CA_18A-41C CA_41C	1		Yes	Yes	Yes	Yes	75	0
		18		Yes	Yes	Yes			
		41	See CA_41C Bandwidth combination set 1 in Table 5.6A.1-1 in TS36.101						
CA_1A-18A-42A	-	1		Yes	Yes	Yes	Yes	55	0
		18		Yes	Yes	Yes			
		42		Yes	Yes	Yes	Yes		
CA_1A-18A-42C	-	1		Yes	Yes	Yes	Yes	75	0
		18		Yes	Yes	Yes			
		42	See CA_42C Bandwidth Combination Set 0 in Table 5.6A.1-1						
CA_1A-19A-21A	CA_1A-19A <sup>6</sup> CA_1A-21A CA_19A-21A	1		Yes	Yes	Yes	Yes	50	0
		19		Yes	Yes	Yes			
		21		Yes	Yes	Yes			
CA_1A-19A-28A	-	1		Yes	Yes	Yes	Yes	45	0
		19		Yes	Yes	Yes			
		28		Yes	Yes				
CA_1A-19A-42A	CA_1A-19A <sup>6</sup> , CA_1A-42A, CA_19A-42A <sup>6</sup>	1		Yes	Yes	Yes	Yes	55	0
		19		Yes	Yes	Yes			
		42		Yes	Yes	Yes	Yes		
CA_1A-19A-42C	CA_1A-19A <sup>6</sup> CA_1A-42A CA_19A-42A <sup>6</sup>	1		Yes	Yes	Yes	Yes	75	0
		19		Yes	Yes	Yes			
		42	See CA_42C Bandwidth combination set 0 in Table 5.6A.1-1						
CA_1A-20A-28A <sup>12</sup>	-	1		Yes	Yes	Yes	Yes	60	0
		20		Yes	Yes	Yes			
		28		Yes	Yes	Yes	Yes		
CA_1A-20A-32A	-	1		Yes	Yes	Yes	Yes	50	0
		20		Yes	Yes				
		32		Yes	Yes	Yes	Yes		
CA_1A-20A-38A	-	1		Yes	Yes	Yes	Yes	60	0
		20		Yes	Yes	Yes	Yes		
		38		Yes	Yes	Yes	Yes		
	-	1		Yes	Yes	Yes	Yes	60	0

CA_1A-20A-42A		20		Yes	Yes	Yes	Yes			
		42		Yes	Yes	Yes	Yes			
CA_1A-20A-43A	-	1		Yes	Yes	Yes		40	0	
		20		Yes						
		43		Yes	Yes	Yes	Yes			
CA_1A-21A-28A	CA_1A-21A, CA_1A-28A, CA_21A-28A	1		Yes	Yes	Yes	Yes	45	0	
		21		Yes	Yes	Yes				
		28		Yes	Yes					
CA_1A-21A-42A	CA_1A-21A, CA_1A-42A, CA_21A-42A	1		Yes	Yes	Yes	Yes	55	0	
		21		Yes	Yes	Yes				
		42		Yes	Yes	Yes	Yes			
CA_1A-21A-42C	CA_1A-21A CA_1A-42A CA_21A-42A	1		Yes	Yes	Yes	Yes	75	0	
		21		Yes	Yes	Yes				
		42	See CA_42C Bandwidth combination set 0 in Table 5.6A.1-1							
CA_1A-21A-42D	-	1		Yes	Yes	Yes	Yes	95	0	
		21		Yes	Yes	Yes				
		42	See CA_42D Bandwidth combination set 0 in Table 5.6A.1-1							
CA_1A-28A-40A	-	1		Yes	Yes	Yes	Yes	60	0	
		28		Yes	Yes	Yes	Yes			
		40		Yes	Yes	Yes	Yes			
CA_1A-28A-40C	-	1		Yes	Yes	Yes	Yes	80	0	
		28		Yes	Yes	Yes	Yes			
		40	See CA_40C Bandwidth combination set 0 in Table 5.6A.1-1							
CA_1A-28A-42A	CA_1A-28A, CA_1A-42A, CA_28A-42A	1		Yes	Yes	Yes	Yes	50	0	
		28		Yes	Yes					
		42		Yes	Yes	Yes	Yes			
CA_1A-28A-42C	CA_1A-28A, CA_1A-42A, CA_28A-42A	1		Yes	Yes	Yes	Yes	70	0	
		28		Yes	Yes					
		42	See CA_42C Bandwidth combination set 0 in Table 5.6A.1-1							
CA_1A-32A-42A	-	1		Yes	Yes	Yes		55	0	
		32		Yes	Yes	Yes	Yes			
		42		Yes	Yes	Yes	Yes			
CA_1A-32A-43A	-	1		Yes	Yes	Yes		55	0	
		32		Yes	Yes	Yes	Yes			
		43		Yes	Yes	Yes	Yes			
CA_1A-41A-42A <sup>10</sup>	CA_1A-42A	1		Yes	Yes	Yes	Yes	60	0	
		41		Yes	Yes	Yes				
		42		Yes	Yes	Yes				
CA_1A-41A-42C <sup>10</sup>	CA_1A-42A, CA_42C, CA_1A-42C	1		Yes	Yes	Yes	Yes	80	0	
		41		Yes	Yes	Yes				
		42	See CA_42C Bandwidth combination Set 1 in Table 5.6A.1-1							
CA_1A-41C-42A <sup>10</sup>	CA_1A-42A	1		Yes	Yes	Yes	Yes	80	0	
		41	See CA_41C Bandwidth combination Set 0 in Table 5.6A.1-1							
		42		Yes	Yes	Yes				
CA_1A-41C-42C <sup>10</sup>	CA_1A-42A, CA_42C, CA_1A-42C	1		Yes	Yes	Yes	Yes	100	0	
		41	See CA_41C Bandwidth combination set 0 in Table 5.6A.1-1							
		42	See CA_42C Bandwidth combination set 1 in Table 5.6A.1-1							
CA_1A-42A-43A	-	1		Yes	Yes	Yes		55	0	
		42		Yes	Yes	Yes	Yes			
		43		Yes	Yes	Yes	Yes			
CA_2A-4A-5A	CA_2A-4A	2		Yes	Yes	Yes	Yes	50	0	
		4		Yes	Yes	Yes	Yes			
		5		Yes	Yes					

CA_2A-2A-4A-5A	CA_2A-5A CA_4A-5A	2	See CA_2A-2A Bandwidth Combination Set 0 in Table 5.6A.1-3				70	0	
		4		Yes	Yes	Yes			Yes
		5		Yes	Yes				
CA_2A-2A-12A-66A-66A	-	2	See CA_2A-2A Bandwidth Combination Set 0 in Table 5.6A.1-3				90	0	
		12		Yes	Yes				
		66	See CA_66A-66A Bandwidth Combination Set 0 in Table 5.6A.1-3						
CA_2A-2A-14A-66A-66A	CA_2A-14A CA_14A-66A	2	See CA_2A-2A Bandwidth Combination Set 0 in Table 5.6A.1-3				90	0	
		14		Yes	Yes				
		66	See CA_66A-66A Bandwidth Combination Set 0 in Table 5.6A.1-3						
CA_2A-4A-5B	-	2		Yes	Yes	Yes	Yes	60	0
		4		Yes	Yes	Yes	Yes		
		5	See CA_5B Bandwidth Combination Set 0 in Table 5.6A.1-1						
CA_2A-4A-7A	CA_2A-4A	2		Yes	Yes	Yes	Yes	60	0
		4		Yes	Yes	Yes	Yes		
		7		Yes	Yes	Yes	Yes		
CA_2A-4A-7A-7A	CA_2A-4A	2		Yes	Yes	Yes	Yes	80	0
		4		Yes	Yes	Yes	Yes		
		7	See the CA_7A-7A Bandwidth combination set 1 in Table 5.6A.1-3						
CA_2A-4A-7C	-	2		Yes	Yes	Yes	Yes	80	0
		4		Yes	Yes	Yes	Yes		
		7	See CA_7C Bandwidth Combination Set 1 in Table 5.6A.1-1						
CA_2A-4A-4A-5A	-	2		Yes	Yes	Yes	Yes	70	0
		4	See CA_4A-4A Bandwidth Combination Set 0 in Table 5.6A.1-3						
		5		Yes	Yes				
CA_2A-4A-12A	CA_2A-4A CA_4A-12A	2		Yes	Yes	Yes	Yes	50	0
		4		Yes	Yes	Yes	Yes		
		12		Yes	Yes				
CA_2A-4A-12A-12A	-	2		Yes	Yes	Yes	Yes	50	0
		4		Yes	Yes	Yes	Yes		
		12	See CA_12A-12A Bandwidth Combination Set 0 in Table 5.6A.1-3						
CA_2A-4A-12B	-	2		Yes	Yes	Yes	Yes	55	0
		4		Yes	Yes	Yes	Yes		
		12	See CA_12B Bandwidth Combination Set 0 in Table 5.6A.1-1						
CA_2A-2A-4A-12A	-	2	See CA_2A-2A Bandwidth Combination Set 0 in Table 5.6A.1-3				70	0	
		4		Yes	Yes	Yes			Yes
		12		Yes	Yes				
CA_2A-4A-4A-12A	-	2		Yes	Yes	Yes	Yes	70	0
		4	See CA_4A-4A Bandwidth Combination Set 0 in Table 5.6A.1-3						
		12		Yes	Yes				
CA_2A-4A-13A	CA_2A-13A CA_4A-13A	2		Yes	Yes	Yes	Yes	50	0
		4		Yes	Yes	Yes	Yes		
		13		Yes					
CA_2A-4A-28A	-	2		Yes	Yes	Yes	Yes	60	0
		4		Yes	Yes	Yes	Yes		
		28		Yes	Yes	Yes	Yes		
CA_2A-4A-29A	CA_2A-4A	2		Yes	Yes	Yes	Yes	50	0
		4		Yes	Yes	Yes	Yes		
		29		Yes	Yes				
CA_2A-4A-30A	-	2		Yes	Yes	Yes	Yes	50	0
		4		Yes	Yes	Yes	Yes		

		30		Yes	Yes							
CA_2A-4A-71A	-	2		Yes	Yes	Yes	Yes		60	0		
		4		Yes	Yes	Yes	Yes					
		71		Yes	Yes	Yes	Yes					
				Yes	Yes	Yes	Yes					
CA_2A-2A-4A-71A	-	2	See CA_2A-2A Bandwidth Combination Set 0 in Table 5.6A.1-3								80	0
		4		Yes	Yes	Yes	Yes					
		71		Yes	Yes	Yes	Yes					
CA_2A-5A-7A	-	2		Yes	Yes	Yes	Yes		50	0		
		5		Yes	Yes							
CA_2A-5A-12A	-	2		Yes	Yes	Yes	Yes		40	0		
		5		Yes	Yes							
		12		Yes	Yes							
CA_2A-2A-5A-12A	-	2	See CA_2A-2A Bandwidth Combination Set 0 in Table 5.6A.1-3								60	0
		5		Yes	Yes							
		12		Yes	Yes							
CA_2A-5A-12A-12A	-	2		Yes	Yes	Yes	Yes		40	0		
		5		Yes	Yes							
		12	See CA_12A-12A Bandwidth Combination Set 0 in Table 5.6A.1-3									
CA_2A-5A-46C	-	2		Yes	Yes	Yes	Yes		70	0		
		5		Yes	Yes							
		46	See CA_46C Bandwidth Combination Set 0 in Table 5.6A.1-1									
CA_2A-2A-5A-66A	CA_2A-5A-66A	2	See CA_2A-2A Bandwidth Combination Set 0 in Table 5.6A.1-3								70	0
		5		Yes	Yes							
		66		Yes	Yes	Yes	Yes					
CA_2A-2A-5A-66A-66A	CA_2A-5A-66A	2	See CA_2A-2A Bandwidth Combination Set 0 in Table 5.6A.1-3								90	0
		5		Yes	Yes							
		66	See CA_66A-66A Bandwidth Combination Set 0 in Table 5.6A.1-3									
CA_2A-2A-5A-66B	CA_2A-5A-66A	2	See CA_2A-2A Bandwidth Combination Set 0 in Table 5.6A.1-3								70	0
		5		Yes	Yes							
		66	See CA_66B Bandwidth combination set 0 in Table 5.6A.1-1									
CA_2A-2A-5A-66C	CA_2A-5A-66A	2	See CA_2A-2A Bandwidth Combination Set 0 in Table 5.6A.1-3								90	0
		5		Yes	Yes							
		66	See CA_66C Bandwidth combination set 0 in Table 5.6A.1-1									
CA_2A-2A-7A-12A	-	2	See CA_2A-2A Bandwidth combination set 0 in Table 5.6A.1-3								70	0
		7		Yes	Yes	Yes	Yes					
		12		Yes	Yes							
CA_2A-2A-7A-66A	-	2	See CA_2A-2A Bandwidth Combination Set 0 in Table 5.6A.1-3								80	0
		7		Yes	Yes	Yes	Yes					
		66		Yes	Yes	Yes	Yes					
CA_2A-2A-12B-66A	-	2	See CA_2A-2A Bandwidth Combination Set 0 in Table 5.6A.1-3								75	0
		12	See CA_12B Bandwidth Combination Set 0 in Table 5.6A.1-1									
		66		Yes	Yes	Yes	Yes					
CA_2A-2A-13A-66A	CA_2A-13A-66A	2	See CA_2A-2A Bandwidth Combination Set 0 in Table 5.6A.1-3								70	0
		13		Yes	Yes							
		66		Yes	Yes	Yes	Yes					
CA_2A-5A-12B	-	2		Yes	Yes	Yes	Yes		45	0		
		5		Yes	Yes							



		12	See CA_12B Bandwidth Combination Set 0 in Table 5.6A.1-1							
CA_2A-5A-13A	CA_2A-13A <sup>6</sup>	2		Yes	Yes	Yes	Yes	40	0	
		5		Yes	Yes					
		13			Yes					
CA_2A-5A-28A	-	2		Yes	Yes	Yes	Yes	50	0	
		5		Yes	Yes					
		28		Yes	Yes	Yes	Yes			
CA_2A-5A-29A	-	2		Yes	Yes	Yes	Yes	40	0	
		5		Yes	Yes					
		29		Yes	Yes					
CA_2A-5A-30A	-	2		Yes	Yes	Yes	Yes	40	0	
		5		Yes	Yes					
		30		Yes	Yes					
CA_2A-2A-5A-30A	-	2	See CA_2A-2A Bandwidth Combination Set 0 in Table 5.6A.1-3				60	0		
		5		Yes	Yes					
		30		Yes	Yes					
CA_2C-5A-30A	-	2	See CA_2C Bandwidth combination set 0 in Table 5.6A.1-1				60	0		
		5		Yes	Yes					
		30		Yes	Yes					
CA_2A-5B-30A	-	2		Yes	Yes	Yes	Yes	50	0	
		5	See CA_5B Bandwidth Combination Set 0 in Table 5.6A.1-1							
		30		Yes	Yes					
CA_2C-5B-30A	-	2	See CA_2C Bandwidth combination set 0 in Table 5.6A.1-1				70	0		
		5	See CA_5B Bandwidth combination set 0 in Table 5.6A.1-1							
		30		Yes	Yes					
CA_2A-5A-46A	-	2		Yes	Yes	Yes	Yes	50	0	
		5		Yes	Yes					
		46					Yes			
CA_2A-5A-46D	CA_2A-5A	2		Yes	Yes	Yes	Yes	90	0	
		5		Yes	Yes					
		46	See CA_46D Bandwidth Combination Set 0 in Table 5.6A.1-1							
CA_2A-5A-46E	-	2		Yes	Yes	Yes	Yes	110	0	
		5		Yes	Yes					
		46	See CA_46E Bandwidth combination set 0 in Table 5.6A.1-1							
CA_2A-5A-48A	CA_2A-48A CA_5A-48A	2	Yes	Yes	Yes	Yes	Yes	50	0	
		5			Yes	Yes				
		48			Yes	Yes	Yes			Yes
CA_2A-5A-48C	CA_2A-48A CA_5A-48A CA_2A-5A	2	Yes	Yes	Yes	Yes	Yes	70	0	
		5			Yes	Yes				
		48	See CA_48D Bandwidth combination set 0 in Table 5.6A.1-1							
CA_2A-5A-48D	CA_2A-5A CA_5A-48A CA_2A-48A	2	Yes	Yes	Yes	Yes	Yes	90	0	
		5			Yes	Yes				
		48	See CA_48C Bandwidth combination set 0 in Table 5.6A.1-1							
CA_2A-5A-66A	CA_2A-5A CA_5A-66A CA_2A-66A	2		Yes	Yes	Yes	Yes	50	0	
		5			Yes	Yes				
		66			Yes	Yes	Yes			Yes
CA_2A-5A-66A-66A	CA_2A-5A CA_5A-66A CA_2A-66A	2		Yes	Yes	Yes	Yes	70	0	
		5			Yes	Yes				
		66	See CA_66A-66A Bandwidth Combination Set 0 in Table 5.6A.1-3							
CA_2A-5B-66A-66A	CA_2A-5A CA_5A-66A	2		Yes	Yes	Yes	Yes	80	0	
		5	See CA_5B Bandwidth Combination Set 0 in Table 5.6A.1-1							

		66	See CA_66A-66A Bandwidth Combination Set 0 in Table 5.6A.1-3						
CA_2A-5A-66B	CA_2A-5A CA_5A-66A	2		Yes	Yes	Yes	Yes		
		5		Yes	Yes				
		66	See CA_66B Bandwidth combination set 0 in Table 5.6A.1-1				50	0	
CA_2A-5A-66C	CA_2A-5A CA_5A-66A	2		Yes	Yes	Yes	Yes		
		5		Yes	Yes				
		66	See CA_66C Bandwidth combination set 0 in Table 5.6A.1-1				70	0	
CA_2A-5A-66D	-	2		Yes	Yes	Yes	Yes		
		5		Yes	Yes				
		66	See CA_66D Bandwidth combination set 0 in Table 5.6A.1-1				90	0	
CA_2A-5B-66A	CA_2A-5A CA_5A-66A	2		Yes	Yes	Yes	Yes		
		5	See CA_5B Bandwidth Combination Set 0 in Table 5.6A.1-1				60	0	
		66		Yes	Yes	Yes	Yes		
CA_2A-5B-66B	CA_2A-5A CA_5A-66A	2		Yes	Yes	Yes	Yes		
		5	See CA_5B Bandwidth Combination Set 0 in Table 5.6A.1-1				60	0	
		66	See CA_66B Bandwidth combination set 0 in Table 5.6A.1-1						
CA_2A-5B-66C	CA_2A-5A CA_5A-66A	2		Yes	Yes	Yes	Yes		
		5	See CA_5B Bandwidth Combination Set 0 in Table 5.6A.1-1				80	0	
		66	See CA_66C Bandwidth combination set 0 in Table 5.6A.1-1						
CA_2A-5B-66A-66A	-	2		Yes	Yes	Yes	Yes		
		5	See CA_5B Bandwidth Combination Set 0 in Table 5.6A.1-1				80	0	
		66	See CA_66A-66A Bandwidth Combination Set 0 in Table 5.6A.1-3						
CA_2A-2A-5B-66A	-	2	See CA_2A-2A Bandwidth Combination Set 0 in Table 5.6A.1-3				80	0	
		5	See CA_5B Bandwidth Combination Set 0 in Table 5.6A.1-1						
		66		Yes	Yes	Yes	Yes		
CA_2A-7A-12A	-	2		Yes	Yes	Yes	Yes		
		7		Yes	Yes	Yes	Yes		
		12		Yes	Yes				
CA_2A-7A-12B	-	2		Yes	Yes	Yes	Yes		
		7		Yes	Yes	Yes	Yes		
		12	See CA_12B Bandwidth combination set 0 in Table 5.6A.1-1				55	0	
CA_2A-7A-13A	-	2		Yes	Yes	Yes	Yes		
		7		Yes	Yes	Yes	Yes		
		13		Yes	Yes				
CA_2A-7C-13A	-	2		Yes	Yes	Yes	Yes		
		7	See CA_7C Bandwidth combination set 1 in Table 5.6A.1-1				70	0	
		13		Yes	Yes				
CA_2A-7A-7A-13A	-	2		Yes	Yes	Yes	Yes		
		7	See CA_7A-7A Bandwidth combination set 1 in Table 5.6A.1-3				70	0	
		13		Yes	Yes				
CA_2A-7A-26A	-	2	Yes	Yes	Yes	Yes	Yes		
		7		Yes	Yes	Yes	Yes		
		26	Yes	Yes	Yes	Yes			
CA_2A-7A-28A	-	2		Yes	Yes	Yes	Yes		
		7		Yes	Yes	Yes	Yes		
		28		Yes	Yes	Yes	Yes		
		2		Yes	Yes	Yes	Yes	80	0

CA_2A-7C-28A		7	See CA_7C Bandwidth Combination Set 1 in Table 5.6A.1-1						
		28		Yes	Yes	Yes			Yes
CA_2A-7A-29A	-	2		Yes	Yes	Yes	Yes	50	0
		7			Yes	Yes	Yes		
		29		Yes	Yes				
CA_2A-7C-29A	-	2		Yes	Yes	Yes	Yes	70	0
		7	See CA_7C Bandwidth combination set 1 in Table 5.6A.1-1						
		29		Yes	Yes				
CA_2A-7A-7A-29A	-	2		Yes	Yes	Yes	Yes	70	0
		7	See CA_7A-7A Bandwidth combination set 1 in Table 5.6A.1-3						
		29		Yes	Yes				
CA_2A-7A-30A	-	2		Yes	Yes	Yes	Yes	50	0
		7		Yes	Yes	Yes	Yes		
		30		Yes	Yes				
CA_2A-7A-46A	-	2		Yes	Yes	Yes	Yes	60	0
		7		Yes	Yes	Yes	Yes		
		46			Yes		Yes		
CA_2A-7A-7A-46A	-	2		Yes	Yes	Yes	Yes	80	0
		7	See CA_7A-7A Bandwidth combination set 1 in table 5.6A.1-3						
		46					Yes		
CA_2A-7A-46C	-	2		Yes	Yes	Yes	Yes	80	0
		7		Yes	Yes	Yes	Yes		
		46	See CA_46C Bandwidth combination set 0 in Table 5.6A.1-1						
CA_2A-7A-7A-46C	-	2		Yes	Yes	Yes	Yes	100	0
		7	See CA_7A-7A Bandwidth combination set 1 in table 5.6A.1-3						
		46	See CA_46C Bandwidth combination set 0 in Table 5.6A.1-1						
CA_2A-7A-46D	-	2		Yes	Yes	Yes	Yes	100	0
		7		Yes	Yes	Yes	Yes		
		46	See CA_46D Bandwidth Combination Set 0 in the Table 5.6A.1-1						
CA_2A-7A-7A-46D	-	2		Yes	Yes	Yes	Yes	120	0
		7	See CA_7A-7A Bandwidth combination set 1 in table 5.6A.1-3						
		46	See CA_46D Bandwidth Combination Set 0 in the Table 5.6A.1-1						
CA_2A-7A-46E	-	2		Yes	Yes	Yes	Yes	120	0
		7		Yes	Yes	Yes	Yes		
		46	See the CA_46E Bandwidth combination set 0 in Table 5.6A.1-1						
CA_2A-7A-7A-46E	-	2		Yes	Yes	Yes	Yes	140	0
		7	See CA_7A-7A Bandwidth combination set 1 in table 5.6A.1-3						
		46	See the CA_46E Bandwidth combination set 0 in Table 5.6A.1-1						
CA_2A-7A-66A	-	2		Yes	Yes	Yes	Yes	60	0
		7		Yes	Yes	Yes	Yes		
		66		Yes	Yes	Yes	Yes		
CA_2A-7A-7A-66A	-	2		Yes	Yes	Yes	Yes	80	0
		7	See CA_7A-7A Bandwidth combination set 1 in Table 5.6A.1-3						
		66		Yes	Yes	Yes	Yes		
CA_2A-7A-7A-66A-66A	-	2		Yes	Yes	Yes	Yes	100	0
		7	See CA_7A-7A Bandwidth combination set 1 in Table 5.6A.1-3						
		66	See CA_66A-66A Bandwidth Combination Set 0 in Table 5.6A.1-3						
	-	2		Yes	Yes	Yes	Yes	80	0

CA_2A-7C-66A		7	See CA_7C Bandwidth combination set 1 in Table 5.6A.1-1						
		66		Yes	Yes	Yes			Yes
CA_2A-7C-66A-66A	-	2		Yes	Yes	Yes	Yes	100	0
		7	See CA_7C Bandwidth combination set 2 in table 5.6A.1-1						
		66	See CA_66A-66A Bandwidth Combination Set 0 in Table 5.6A.1-3						
CA_2A-7A-66A-66A	-	2		Yes	Yes	Yes	Yes	80	0
		7		Yes	Yes	Yes	Yes		
		66	See CA_66A-66A Bandwidth combination set 0 in Table 5.6A.1-3						
CA_2A-12A-30A	CA_2A-12A <sup>6</sup>	2		Yes	Yes	Yes	Yes	40	0
		12		Yes	Yes				
		30		Yes	Yes				
CA_2A-2A-12A-30A	-	2	See CA_2A-2A Bandwidth combination set 0 in Table 5.6A.1-3				60	0	
		12		Yes	Yes				
		30		Yes	Yes				
CA_2C-12A-30A	-	2	See CA_2C Bandwidth combination set 0 in Table 5.6A.1-1				60	0	
		12		Yes	Yes				
		30		Yes	Yes				
CA_2A-12A-66A	CA_2A-12A, CA_2A-66A CA_12A-66A	2		Yes	Yes	Yes	Yes	50	0
		12		Yes	Yes				
		66		Yes	Yes	Yes	Yes		
		2		Yes	Yes			40	1
		12		Yes	Yes				
66		Yes	Yes	Yes	Yes				
CA_2A-2A-12A-66A	-	2	See CA_2A-2A Bandwidth Combination Set 0 in Table 5.6A.1-3				70	0	
		12		Yes	Yes				
		66		Yes	Yes	Yes			Yes
CA_2A-12A-66A-66A	-	2		Yes	Yes	Yes	Yes	70	0
		12		Yes	Yes				
		66	See CA_66A-66A Bandwidth Combination Set 0 in Table 5.6A.1-3						
CA_2A-12A-66C	-	2		Yes	Yes	Yes	Yes	70	0
		12		Yes	Yes				
		66	See CA_66C Bandwidth Combination Set 0 in Table 5.6A.1-1						
CA_2A-12B-66A	-	2		Yes	Yes	Yes	Yes	55	0
		12	See CA_12B Bandwidth Combination Set 0 in Table 5.6A.1-1						
		66		Yes	Yes	Yes	Yes		
CA_2A-12B-66A-66A	-	2		Yes	Yes	Yes	Yes	75	0
		12	See CA_12B Bandwidth Combination Set 0 in Table 5.6A.1-1						
		66	See CA_66A-66A Bandwidth Combination Set 0 in Table 5.6A.1-3						
CA_2A-13A-46A	CA_2A-13A	2		Yes	Yes	Yes	Yes	50	0
		13		Yes	Yes				
		46					Yes		
CA_2A-13A-46C	CA_2A-13A	2		Yes	Yes	Yes	Yes	70	0
		13		Yes	Yes				
		46	See CA_46C Bandwidth Combination Set 0 in Table 5.6A.1-1						
CA_2A-13A-46D	CA_2A-13A	2		Yes	Yes	Yes	Yes	90	0
		13		Yes	Yes				
		46	See CA_46D Bandwidth Combination Set 0 in Table 5.6A.1-1						
CA_2A-13A-46E	CA_2A-13A	2		Yes	Yes	Yes	Yes	110	0
		13		Yes	Yes				
		46	See CA_46E Bandwidth Combination Set 0 in Table 5.6A.1-1						

CA_2A-13A-46A-46D	CA_2A-13A	2	Yes	Yes	Yes	Yes	Yes	Yes	110	0
		13			Yes	Yes				
		46	See CA_46A-46D Bandwidth Combination Set 0 in Table 5.6A.1-3							
CA_2A-13A-46A-46C	CA_2A-13A	2	Yes	Yes	Yes	Yes	Yes	Yes	90	0
		13			Yes	Yes				
		46	See CA_46A-46C Bandwidth Combination Set 0 in the Table 5.6A.1-3							
CA_2A-13A-46A-46A	CA_2A-13A	2	Yes	Yes	Yes	70	0	Yes	70	0
		13			Yes	Yes				
		46	See CA_46A-46A Bandwidth combination set 0 in Table 5.6A.1-3							
CA_2A-13A-48A	CA_2A-48A CA_13A-48A	2			Yes	Yes	Yes	Yes	50	0
		13			Yes	Yes				
		48			Yes	Yes	Yes	Yes		
CA_2A-13A-48A-48A	-	2			Yes	Yes	Yes	Yes	70	0
		13			Yes	Yes				
		48	See CA_48A-48A Bandwidth combination set 0 in Table 5.6A.1-3							
CA_2A-13A-48C	CA_2A-48A CA_13A-48A CA_2A-13A	2			Yes	Yes	Yes	Yes	70	0
		13			Yes	Yes				
		48	See CA_48C Bandwidth Combination Set 0 in Table 5.6A.1-1							
CA_2A-13A-48D	CA_2A-48A CA_13A-48A	2			Yes	Yes	Yes	Yes	90	0
		13			Yes	Yes				
		48	See CA_48D Bandwidth combination set 0 in the Table 5.6A.1-1							
CA_2A-13A-48A-48C	CA_2A-13A	2			Yes	Yes	Yes	Yes	90	0
		13			Yes	Yes				
		48	See CA_48A-48C Bandwidth combination set 0 in the Table 5.6A.1-3							
CA_2A-13A-66A	CA_2A-13A CA_13A-66A CA_2A-66A	2			Yes	Yes	Yes	Yes	50	0
		13			Yes	Yes				
		66			Yes	Yes	Yes	Yes		
CA_2A-13A-66D	-	2			Yes	Yes	Yes	Yes	90	0
		13			Yes	Yes				
		66	See CA_66D Bandwidth combination set 0 in Table 5.6A.1-1							
CA_2A-13A-66A-66A	CA_2A-13A CA_13A-66A CA_2A-66A	2			Yes	Yes	Yes	Yes	70	0
		13			Yes	Yes				
		66	See CA_66A-66A Bandwidth Combination Set 0 in Table 5.6A.1-3							
CA_2A-13A-66A-66B	CA_2A-13A CA_13A-66A	2			Yes	Yes	Yes	Yes	70	0
		13			Yes	Yes				
		66	See CA_66A-66B Bandwidth Combination Set 0 in Table 5.6A.1-3							
CA_2A-13A-66A-66C	CA_2A-13A CA_13A-66A	2			Yes	Yes	Yes	Yes	90	0
		13			Yes	Yes				
		66	See CA_66A-66C Bandwidth Combination Set 0 in Table 5.6A.1-3							
CA_2A-13A-66B	CA_2A-13A CA_13A-66A	2			Yes	Yes	Yes	Yes	50	0
		13			Yes	Yes				
		66	See CA_66B Bandwidth combination set 0 in Table 5.6A.1-1							
CA_2A-13A-66C	CA_2A-13A CA_13A-66A	2			Yes	Yes	Yes	Yes	70	0
		13			Yes	Yes				
		66	See CA_66C Bandwidth combination set 0 in Table 5.6A.1-1							
CA_2A-2A-13A-66B	-	2	See CA_2A-2A Bandwidth Combination Set 0 in Table 5.6A.1-3						70	0
		13			Yes	Yes				
		66	See CA_66B Bandwidth combination set 0 in Table 5.6A.1-1							
CA_2A-2A-13A-66A-66A	-	2	See CA_2A-2A Bandwidth Combination Set 0 in Table 5.6A.1-3						90	0
		13			Yes	Yes				

		66	See CA_66A-66A Bandwidth Combination Set 0 in Table 5.6A.1-3						
CA_2A-14A-30A	CA_2A-14A CA_14A-30A	2		Yes	Yes	Yes	Yes		
		14		Yes	Yes				
		30		Yes	Yes				
CA_2A-2A-14A-30A	-	2	See CA_2A-2A Bandwidth Combination Set 0 in Table 5.6A.1-3				60	0	
		14		Yes	Yes				
		30		Yes	Yes				
CA_2A-14A-66A	CA_2A-14A CA_14A-66A	2		Yes	Yes	Yes	Yes		
		14		Yes	Yes				
		66		Yes	Yes	Yes	Yes		
CA_2A-2A-14A-66A	CA_2A-14A CA_14A-66A	2	See CA_2A-2A Bandwidth Combination Set 0 in Table 5.6A.1-3				70	0	
		14		Yes	Yes				
		66		Yes	Yes	Yes			Yes
CA_2A-14A-66A-66A	CA_2A-14A CA_14A-66A	2		Yes	Yes	Yes	Yes		
		14		Yes	Yes				
		66	See CA_66A-66A Bandwidth combination set 0 in Table 5.6A.1-3				70	0	
2		Yes	Yes	Yes	Yes				
14		Yes	Yes						
CA_2A-14A-66A-66A-66A	CA_2A-14A CA_14A-66A	66	See CA_66A-66A-66A Bandwidth Combination Set 0 in Table 5.6A.1-4				90	0	
		2		Yes	Yes	Yes			Yes
		14		Yes	Yes				
CA_2A-26A-66A	-	2		Yes	Yes	Yes	Yes		
		26		Yes	Yes	Yes	Yes		
		66		Yes	Yes	Yes	Yes		
CA_2A-28A-66A	-	2		Yes	Yes	Yes	Yes		
		28		Yes	Yes	Yes	Yes		
		66		Yes	Yes	Yes	Yes		
CA_2A-29A-30A	-	2		Yes	Yes	Yes	Yes		
		29		Yes	Yes				
		30		Yes	Yes				
CA_2A-2A-29A-30A	-	2	See CA_2A-2A Bandwidth Combination Set 0 in Table 5.6A.1-3				60	0	
		29		Yes	Yes				
		30		Yes	Yes				
CA_2C-29A-30A	-	2	See CA_2C Bandwidth Combination set 0 in Table 5.6A.1-1				60	0	
		29		Yes	Yes				
		30		Yes	Yes				
CA_2A-29A-66A	-	2		Yes	Yes	Yes	Yes		
		29		Yes	Yes				
		66		Yes	Yes	Yes	Yes		
CA_2A-2A-30A-66A	-	2	See CA_2A-2A Bandwidth Combination Set 0 in Table 5.6A.1-3				70	0	
		30		Yes	Yes				
		66		Yes	Yes	Yes			Yes
CA_2A-30A-66A-66A	-	2		Yes	Yes	Yes	Yes		
		30		Yes	Yes				
		66	See CA_66A-66A Bandwidth Combination Set 0 in Table 5.6A.1-3				70	0	
2		Yes	Yes	Yes	Yes				
30		Yes	Yes						
CA_2A-30A-66A	-	2		Yes	Yes	Yes	Yes		
		30		Yes	Yes				
		66		Yes	Yes	Yes	Yes		
CA_2A-46A-48A	CA_2A-48A	2		Yes	Yes	Yes	Yes		
		46				Yes			
		48		Yes	Yes	Yes	Yes		
CA_2A-46A-48C	CA_2A-48A	2		Yes	Yes	Yes	Yes		
		46				Yes			
		48	See the CA_48C Bandwidth combination set 0 in Table 5.6A.1-1				80	0	
2		Yes	Yes	Yes	Yes				
46				Yes	Yes				

		48	See CA_48D Bandwidth combination set 0 in Table 5.6A.1-1								
CA_2A-46A-48E	-	2		Yes	Yes	Yes	Yes			120	0
		46						Yes			
		48	See the CA_48E Bandwidth combination set 0 in Table 5.6A.1-1								
CA_2A-46C-48A	CA_2A-48A	2		Yes	Yes	Yes	Yes			80	0
		46	See the CA_46C Bandwidth combination set 0 in Table 5.6A.1-1								
		48		Yes	Yes	Yes	Yes				
CA_2A-46C-48C	CA_2A-48A	2		Yes	Yes	Yes	Yes			100	0
		46	See CA_46C Bandwidth combination set 0 in Table 5.6A.1-1								
		48	See CA_48C Bandwidth combination set 0 in Table 5.6A.1-1								
CA_2A-46D-48A	CA_2A-48A	2		Yes	Yes	Yes	Yes			100	0
		46	See CA_46D Bandwidth combination set 0 in Table 5.6A.1-1								
		48		Yes	Yes	Yes	Yes				
CA_2A-46A-66A	CA_2A-66A	2		Yes	Yes	Yes	Yes			60	0
		46						Yes			
		66		Yes	Yes	Yes	Yes				
CA_2A-46A-46A-66A	-	2		Yes	Yes	Yes	Yes			80	0
		46	See CA_46A-46A Bandwidth combination set 0 in Table 5.6A.1-3								
		66		Yes	Yes	Yes	Yes				
CA_2A-46C-48D	-	2		Yes	Yes	Yes	Yes			120	0
		46	See the CA_46C Bandwidth combination set 0 in Table 5.6A.1-1								
		48	See the CA_48D Bandwidth combination set 0 in Table 5.6A.1-1								
CA_2A-46C-48E	-	2		Yes	Yes	Yes	Yes			140	0
		46	See the CA_46C Bandwidth combination set 0 in Table 5.6A.1-1								
		48	See the CA_48E Bandwidth combination set 0 in Table 5.6A.1-1								
CA_2A-46C-66A	CA_2A-66A	2		Yes	Yes	Yes	Yes			80	0
		46	See CA_46C Bandwidth combination set 0 in Table 5.6A.1-1								
		66		Yes	Yes	Yes	Yes				
CA_2A-46A-66A-66A	-	2		Yes	Yes	Yes	Yes			80	0
		46						Yes			
		66	See the CA_66A-66A Bandwidth combination set 0 in the Table 5.6A.1-3								
CA_2A-46C-66A-66A	-	2		Yes	Yes	Yes	Yes			100	0
		46	See the CA_46C Bandwidth combination set 0 in the Table 5.6A.1-1								
		66	See the CA_66A-66A Bandwidth combination set 0 in the Table 5.6A.1-3								
CA_2A-46D-66A-66A	-	2		Yes	Yes	Yes	Yes			120	0
		46	See the CA_46D Bandwidth combination set 0 in the Table 5.6A.1-1								
		66	See the CA_66A-66A Bandwidth combination set 0 in the Table 5.6A.1-3								
CA_2A-46E-66A-66A	-	2		Yes	Yes	Yes	Yes			140	0
		46	See the CA_46E Bandwidth combination set 0 in the Table 5.6A.1-1								
		66	See the CA_66A-66A Bandwidth combination set 0 in the Table 5.6A.1-3								
CA_2A-46A-46C-66A	-	2		Yes	Yes	Yes	Yes			100	0
		46	See CA_46A-46C Bandwidth Combination Set 0 in the Table 5.6A.1-3								
		66		Yes	Yes	Yes	Yes				
CA_2A-46D-66A	CA_2A-66A	2		Yes	Yes	Yes	Yes			100	0
		46	See CA_46D Bandwidth Combination Set 0 in the Table 5.6A.1-1								

		66			Yes	Yes	Yes	Yes			
		2			Yes	Yes	Yes	Yes			
CA_2A-46D-48C	CA_2A-48A	46	See the CA_46D Bandwidth combination set 0 in Table 5.6A.1-1						120	0	
		48	See the CA_48C Bandwidth combination set 0 in Table 5.6A.1-1								
CA_2A-46E-48A	CA_2A-48A	2			Yes	Yes	Yes	Yes	120	0	
		46	See the CA_46E Bandwidth combination set 0 in Table 5.6A.1-1								
		48			Yes	Yes	Yes	Yes			
CA_2A-46E-66A	CA_2A-66A	2			Yes	Yes	Yes	Yes	120	0	
		46	See CA_46E Bandwidth Combination Set 0 in the Table 5.6A.1-1								
		66			Yes	Yes	Yes	Yes			
CA_2A-46E-48C		2			Yes	Yes	Yes	Yes	140	0	
		46	See the CA_46E Bandwidth combination set 0 in Table 5.6A.1-1								
		48	See the CA_48C Bandwidth combination set 0 in Table 5.6A.1-1								
CA_2A-48A-66A	CA_2A-48A CA_48A-66A CA_2A-66A	2			Yes	Yes	Yes	Yes	60	0	
		48			Yes	Yes	Yes	Yes			
		66			Yes	Yes	Yes	Yes			
CA_2A-48C-66A	CA_2A-48A CA_48A-66A	2			Yes	Yes	Yes	Yes	80	0	
		48	See CA_48C Bandwidth combination set 0 in Table 5.6A.1-1								
		66			Yes	Yes	Yes	Yes			
CA_2A-48C-66A-66A	CA_48A-66A CA_2A-66A CA_2A-48A	2	Yes	Yes	Yes	Yes	Yes	Yes	100	0	
		48	See CA_48C Bandwidth combination set 0 in the Table 5.6A.1-1								
		66	See CA_66A-66A Bandwidth combination set 0 in the Table 5.6A.1-3								
CA_2A-48D-66A	CA_48A-66A CA_2A-48A CA_2A-66A	2			Yes	Yes	Yes	Yes	100	0	
		48	See CA_48D Bandwidth combination set 0 in the Table 5.6A.1-1								
		66			Yes	Yes	Yes	Yes			
CA_2A-48D-66A-66A	CA_48A-66A CA_2A-66A CA_2A-48A	2	Yes	Yes	Yes	Yes	Yes	Yes	120	0	
		48	See CA_48D Bandwidth combination set 0 in the Table 5.6A.1-1								
		66	See CA_66A-66A Bandwidth combination set 0 in the Table 5.6A.1-3								
CA_2A-48E-66A	CA_48A-66A CA_2A-66A CA_2A-48A	2			Yes	Yes	Yes	Yes	120	0	
		48	See CA_48E Bandwidth combination set 0 in Table 5.6A.1-1								
		66			Yes	Yes	Yes	Yes			
CA_2A-48E-66A-66A	CA_48A-66A CA_2A-66A CA_2A-48A	2	Yes	Yes	Yes	Yes	Yes	Yes	140	0	
		48	See CA_48E Bandwidth combination set 0 in the Table 5.6A.1-1								
		66	See CA_66A-66A Bandwidth combination set 0 in the Table 5.6A.1-3								
CA_2A-48A-48A-66A	-	2			Yes	Yes	Yes	Yes	80	0	
		48	See CA_48A-48A Bandwidth combination set 0 in Table 5.6A.1-3								
		66			Yes	Yes	Yes	Yes			
CA_2A-48A-48C-66A	-	2			Yes	Yes	Yes	Yes	100	0	
		48	See CA_48A-48C Bandwidth combination set 0 in the Table 5.6A.1-3								
		66			Yes	Yes	Yes	Yes			
CA_2A-48A-66A-66A	CA_48A-66A CA_2A-48A CA_2A-66A	2			Yes	Yes	Yes	Yes	80	0	
		48			Yes	Yes	Yes	Yes			
		66	See CA_66A-66A Bandwidth combination set 0 in the Table 5.6A.1-3								
CA_2A-66A-71A	-	2			Yes	Yes	Yes	Yes	60	0	
		66			Yes	Yes	Yes	Yes			
		71			Yes	Yes	Yes	Yes			
CA_2A-2A-66A-71A	-	2	See CA_2A-2A Bandwidth Combination Set 0 in Table 5.6A.1-3						80	0	



		66			Yes	Yes	Yes	Yes			
		71			Yes	Yes	Yes	Yes			
		2			Yes	Yes	Yes	Yes			
CA_2A-66A-66A-71A	-	66	See CA_66A-66A Bandwidth Combination Set 0 in Table 5.6A.1-3							80	0
		71			Yes	Yes	Yes	Yes			
		2			Yes	Yes	Yes	Yes			
CA_2A-66C-71A	-	66	See CA_66C Bandwidth Combination Set 0 in Table 5.6A.1-1							80	0
		71			Yes	Yes	Yes	Yes			
		3			Yes	Yes	Yes	Yes			
CA_3A-5A-7A	CA_3A-5A, CA_3A-7A, CA_5A-7A	5			Yes	Yes				50	
		7			Yes	Yes	Yes	Yes			
CA_3A-5A-7A	-	3			Yes	Yes	Yes	Yes		50	
		5			Yes	Yes				1	
		7			Yes	Yes	Yes	Yes			
CA_3A-3A-5A-7A	-	3	See CA_3A-3A Bandwidth Combination Set 0 in Table 5.6A.1-3							70	0
		5			Yes	Yes					
		7			Yes	Yes	Yes	Yes			
CA_3A-5A-7A-7A	CA_3A-5A, CA_3A-7A, CA_5A-7A	3			Yes	Yes	Yes	Yes		70	
		5			Yes	Yes				0	
		7	See CA_7A-7A Bandwidth Combination Set 3 in Table 5.6A.1-3								
CA_3A-5A-7C	-	3			Yes	Yes	Yes	Yes		70	
		5			Yes	Yes				0	
		7	See CA_7C Bandwidth Combination Set 1 in Table 5.6A.1-1								
CA_3A-5A-28A	-	3			Yes	Yes	Yes	Yes		50	
		5			Yes	Yes				0	
		28			Yes	Yes	Yes	Yes			
CA_3A-3A-5A-28A	-	3	See CA_3A-3A Bandwidth Combination Set 0 in Table 5.6A.1-3							70	0
		5			Yes	Yes					
		28			Yes	Yes	Yes	Yes			
CA_3A-5A-40A	CA_3A-5A	3			Yes	Yes	Yes	Yes		50	
		40			Yes	Yes	Yes	Yes		0	
		3			Yes	Yes	Yes	Yes			
		5		Yes	Yes	Yes				40	
		40		Yes	Yes	Yes		Yes		1	
CA_3A-5A-40A-40A	-	3			Yes	Yes				60	
		5			Yes	Yes				0	
		40	See CA_40A-40A Bandwidth Combination Set 0 in Table 5.6A.1-3								
CA_3A-5A-41A	-	3			Yes	Yes	Yes	Yes		50	
		5			Yes	Yes				0	
		41						Yes			
CA_3C-7A-8A	-	3	See CA_3C Bandwidth combination set 0 in Table 5.6A.1-1							70	0
		7			Yes	Yes	Yes	Yes			
		8			Yes	Yes					
CA_3A-3A-7A-8A	CA_3A-7A, CA_3A-8A, CA_7A-8A	3	See CA_3A-3A Bandwidth Combination Set 0 in Table 5.6A.1-3							70	0
		7			Yes	Yes	Yes	Yes			
		8			Yes	Yes					
		3	See CA_3A-3A Bandwidth Combination Set 1 in Table 5.6A.1-3							60	1
		7			Yes	Yes	Yes	Yes			
		8			Yes	Yes					
CA_3A-3A-7A-7A-8A	CA_3A-7A, CA_3A-8A, CA_7A-8A	3	See CA_3A-3A Bandwidth Combination Set 0 in table 5.6A.1-3							90	0
		7	See CA_7A-7A Bandwidth Combination Set 1 in table 5.6A.1-3								
		8			Yes	Yes					

		3	See CA_3A-3A Bandwidth Combination Set 1 in table 5.6A.1-3				70	1	
		7	See CA_7A-7A Bandwidth Combination Set 2 in table 5.6A.1-3						
		8		Yes	Yes				
CA_3A-7A-7A-8A	CA_3A-7A, CA_3A-8A, CA_7A-8A	3		Yes	Yes	Yes	Yes	70	0
		7	See CA_7A-7A Bandwidth Combination Set 1 in Table 5.6A.1-3						
		8		Yes	Yes				
		3		Yes	Yes	Yes	Yes	60	1
		7	See CA_7A-7A Bandwidth Combination Set 2 in Table 5.6A.1-3						
		8		Yes	Yes				
CA_3A-7A-8A	CA_3A-7A, CA_3A-8A, CA_7A-8A	3		Yes	Yes	Yes		40	0
		7		Yes	Yes				
		8		Yes	Yes				
		3		Yes	Yes	Yes	Yes	50	1
		7		Yes	Yes	Yes	Yes		
		8		Yes	Yes				
		3		Yes	Yes	Yes	Yes	50	2
		7		Yes	Yes	Yes	Yes		
8		Yes	Yes						
CA_3A-7A-20A	CA_3A-7A CA_3A-20A CA_7A-20A	3		Yes	Yes	Yes	Yes	60	0
		7		Yes	Yes	Yes	Yes		
		20		Yes	Yes	Yes	Yes		
		3		Yes	Yes	Yes	Yes	60	1
		7		Yes	Yes	Yes	Yes		
		20		Yes	Yes	Yes	Yes		
CA_3A-7A-7A-20A	-	3		Yes	Yes	Yes	Yes	80	0
		7	See CA_7A-7A Bandwidth Combination Set 3 in Table 5.6A.1-3						
		20		Yes	Yes	Yes	Yes		
CA_3A-3A-7A-20A	-	3	See CA_3A-3A Bandwidth combination set 0 in Table 5.6A.1-3				80	0	
		7		Yes	Yes	Yes			Yes
		20		Yes	Yes	Yes			Yes
CA_3C-7A-20A	-	3	See CA_3C Bandwidth combination set 0 in Table 5.6A.1-1				80	0	
		7		Yes	Yes	Yes			Yes
		20		Yes	Yes	Yes			Yes
		3	See CA_3C Bandwidth combination set 0 in Table 5.6A.1-1				80	1	
		7		Yes	Yes	Yes			Yes
		20		Yes	Yes	Yes			Yes
CA_3C-7C-20A	-	3	See CA_3C Bandwidth combination set 0 in Table 5.6A.1-1				100	0	
		7	See CA_7C Bandwidth combination set 1 in Table 5.6A.1-1						
		20		Yes	Yes	Yes			Yes
CA_3A-7C-20A	-	3		Yes	Yes	Yes	Yes	80	0
		7	See CA_7C Bandwidth combination set 1 in Table 5.6A.1-1						
		20		Yes	Yes	Yes	Yes		
CA_3A-7A-26A	CA_3A-7A, CA_3A-26A, CA_7A-26A	3		Yes	Yes	Yes	Yes	55	0
		7		Yes	Yes	Yes	Yes		
		26		Yes	Yes	Yes			
CA_3A-7A-7A-26A	CA_3A-7A, CA_3A-26A, CA_7A-26A	3		Yes	Yes	Yes	Yes	75	0
		7	See CA_7A-7A Bandwidth Combination Set 3 in Table 5.6A.1-3						
		26		Yes	Yes	Yes			
CA_3A-7A-28A	CA_3A-7A, CA_3A-28A <sup>6</sup> , CA_7A-28A	3		Yes	Yes	Yes	Yes	60	0
		7		Yes	Yes	Yes	Yes		
		28		Yes	Yes	Yes	Yes		

CA_3A-3A-7A-28A	-	3	See CA_3A-3A Bandwidth Combination Set 0 in Table 5.6A.1-3				80	0	
		7		Yes	Yes	Yes			Yes
		28		Yes	Yes	Yes			Yes
CA_3A-3A-7C-28A	CA_7C	3	See CA_3A-3A Bandwidth Combination Set 0 in Table 5.6A.1-3				100	0	
		7	See CA_7C Bandwidth Combination Set 2 in Table 5.6A.1-1						
		28		Yes	Yes	Yes			Yes
CA_3A-7A-7A-28A	-	3	See CA_7A-7A Bandwidth combination set 3 in Table 5.6A.1-3				80	0	
		7	See CA_7A-7A Bandwidth combination set 3 in Table 5.6A.1-3						
		28		Yes	Yes	Yes			Yes
CA_3A-7C-28A	CA_3A-7A, CA_7C, CA_7A-28A	3	See CA_7C Bandwidth Combination Set 2 in Table 5.6A.1-1				80	0	
		28		Yes	Yes	Yes			Yes
		3		Yes	Yes	Yes			Yes
		7	See CA_7C Bandwidth Combination Set 1 in Table 5.6A.1-1				80	1	
		28		Yes	Yes	Yes			Yes
		3		Yes	Yes	Yes			Yes
CA_3C-7A-28A	CA_3C	3	See CA_3C Bandwidth Combination Set 0 in Table 5.6A.1-1				80	0	
		7		Yes	Yes	Yes			Yes
		28		Yes	Yes	Yes			Yes
CA_3C-7C-28A	CA_3C CA_7C	3	See CA_3C Bandwidth Combination Set 0 in Table 5.6A.1-1				100	0	
		7	See CA_7C Bandwidth Combination Set 2 in Table 5.6A.1-1						
		28		Yes	Yes	Yes			Yes
CA_3A-7A-32A	CA_3A-7A	3		Yes	Yes	Yes	Yes	60	0
		7		Yes	Yes	Yes	Yes		
		32		Yes	Yes	Yes	Yes		
CA_3C-7A-32A	-	3	See CA_3C Bandwidth combination set 0 in Table 5.6A.1-1				80	0	
		7		Yes	Yes	Yes			Yes
		32		Yes	Yes	Yes			Yes
CA_3A-7A-38A <sup>7</sup>	-	3	See CA_3A-7A Bandwidth combination set 0 in Table 5.6A.1-1				60	0	
		7		Yes	Yes	Yes			Yes
		38		Yes	Yes	Yes			Yes
CA_3C-7A-38A <sup>7</sup>	-	3	See CA_3C Bandwidth combination set 0 in Table 5.6A.1-1				80	0	
		7		Yes	Yes	Yes			Yes
		38		Yes	Yes	Yes			Yes
CA_3A-7A-40A	-	3		Yes	Yes	Yes	Yes	60	0
		7		Yes	Yes	Yes	Yes		
		40		Yes	Yes	Yes	Yes		
CA_3A-7A-40C	-	3		Yes	Yes	Yes	Yes	80	0
		7		Yes	Yes	Yes	Yes		
		40	See CA_40C Bandwidth combination set 1 in Table 5.6A.1-1						
CA_3A-7A-42A	-	3		Yes	Yes	Yes	Yes	60	0
		7		Yes	Yes	Yes	Yes		
		42		Yes	Yes	Yes	Yes		
CA_3A-7A-46A	-	3		Yes	Yes	Yes	Yes	60	0
		7		Yes	Yes	Yes	Yes		
		46					Yes		
CA_3A-7C-46A	-	3		Yes	Yes	Yes	Yes	80	0
		7	See CA_7C Bandwidth Combination Set 2 in Table 5.6A.1-1						
		46					Yes		
	-	3		Yes	Yes	Yes	Yes	100	0

CA_3A-7C-46C		7	See CA_7C Bandwidth Combination Set 2 in Table 5.6A.1-1						
		46	See CA_46C Bandwidth Combination Set 0 in Table 5.6A.1-1						
CA_3A-7C-46D	-	3		Yes	Yes	Yes	Yes	120	0
		7	See CA_7C Bandwidth Combination Set 2 in Table 5.6A.1-1						
		46	See CA_46D Bandwidth Combination Set 0 in Table 5.6A.1-1						
CA_3A-7C-46E	-	3		Yes	Yes	Yes	Yes	140	0
		7	See CA_7C Bandwidth Combination Set 2 in Table 5.6A.1-1						
		46	See CA_46E Bandwidth Combination Set 0 in Table 5.6A.1-1						
CA_3A-7A-46C	-	3		Yes	Yes	Yes	Yes	80	0
		7		Yes	Yes	Yes	Yes		
		46	See CA_46C Bandwidth Combination Set 0 in Table 5.6A.1-1						
CA_3A-7A-46D	-	3		Yes	Yes	Yes	Yes	100	0
		7		Yes	Yes	Yes	Yes		
		46	See CA_46D Bandwidth Combination Set 0 in Table 5.6A.1-1						
CA_3A-7A-46E	-	3		Yes	Yes	Yes	Yes	120	0
		7		Yes	Yes	Yes	Yes		
		46	See CA_46E Bandwidth Combination Set 0 in Table 5.6A.1-1						
CA_3A-8A-11A	-	3		Yes	Yes	Yes	Yes	40	0
		8		Yes	Yes				
		11		Yes	Yes				
CA_3A-8A-20A	-	3		Yes	Yes	Yes	Yes	40	0
		8		Yes	Yes				
		20		Yes	Yes				
CA_3A-8A-28A	-	3		Yes	Yes	Yes	Yes	50	0
		8	Yes	Yes	Yes				
		28		Yes	Yes	Yes	Yes		
CA_3A-8A-32A	-	3		Yes	Yes	Yes	Yes	50	0
		8	Yes	Yes	Yes				
		32		Yes	Yes	Yes	Yes		
CA_3A-8A-38A	CA_3A-8A	3		Yes	Yes	Yes	Yes	50	0
		8		Yes	Yes				
		38		Yes	Yes	Yes	Yes		
CA_3C-8A-38A	-	3	See CA_3C Bandwidth combination set 0 in Table 5.6A.1-1				70	0	
		8		Yes	Yes				
		38		Yes	Yes	Yes			Yes
CA_3A-8A-40A	CA_3A-8A	3		Yes	Yes	Yes	Yes	50	0
		8	Yes	Yes	Yes				
		40		Yes	Yes	Yes	Yes		
CA_3A-8A-40C	-	3		Yes	Yes	Yes	Yes	70	0
		8		Yes	Yes				
		40	See CA_40C Bandwidth combination set 1 in Table 5.6A.1-1						
CA_3A-8A-42A	-	3		Yes	Yes	Yes	Yes	50	0
		8		Yes	Yes				
		42		Yes	Yes	Yes	Yes		
CA_3A-8A-42C	-	3		Yes	Yes	Yes	Yes	70	0
		8		Yes	Yes				
		42	See CA_42C Bandwidth Combination Set 0 in Table 5.6A.1-1						
CA_3A-11A-18A	CA_3A-11A, CA_3A-18A, CA_11A-18A	3		Yes	Yes	Yes	Yes	45	0
		11		Yes	Yes				
		18		Yes	Yes	Yes			
		3		Yes	Yes	Yes	Yes	45	0

CA_3A-11A-26A	CA_3A-11A, CA_3A-26A, CA_11A-26A	11		Yes	Yes				
		26		Yes	Yes	Yes			
CA_3A-11A-28A	-	3		Yes	Yes	Yes	Yes	50	0
		11		Yes	Yes				
		28		Yes	Yes	Yes	Yes		
CA_3A-18A-42A	-	3		Yes	Yes	Yes	Yes	55	0
		18		Yes	Yes	Yes			
		42		Yes	Yes	Yes	Yes		
CA_3A-18A-42C	-	3		Yes	Yes	Yes	Yes	75	0
		18		Yes	Yes	Yes			
		42	See CA_42C Bandwidth Combination Set 0 in Table 5.6A.1-1						
CA_3A-19A-21A	CA_3A-19A, CA_3A-21A, CA_19A-21A	3		Yes	Yes	Yes	Yes	50	0
		19		Yes	Yes	Yes			
		21		Yes	Yes	Yes			
CA_3A-3A-19A-21A	CA_3A-19A, CA_3A-21A, CA_19A-21A	3	See CA_3A-3A Bandwidth Combination Set 0 in Table 5.6A.1-3					70	0
		19		Yes	Yes	Yes			
		21		Yes	Yes	Yes			
CA_3A-19A-42A	CA_3A-19A, CA_3A-42A, CA_19A-42A <sup>6</sup>	3		Yes	Yes	Yes	Yes	55	0
		19		Yes	Yes	Yes			
		42		Yes	Yes	Yes	Yes		
CA_3A-19A-42C	CA_3A-19A, CA_3A-42A, CA_19A-42A <sup>6</sup>	3		Yes	Yes	Yes	Yes	75	0
		19		Yes	Yes	Yes			
		42	See CA_42C Bandwidth combination set 0 in Table 5.6A.1-1						
CA_3A-19A-42D	-	3		Yes	Yes	Yes	Yes	95	0
		19		Yes	Yes	Yes			
		42	See CA_42D Bandwidth combination set 0 in Table 5.6A.1-1						
CA_3A-20A-28A <sup>12</sup>	-	3		Yes	Yes	Yes	Yes	60	0
		20			Yes	Yes	Yes		
		28		Yes	Yes	Yes	Yes		
CA_3A-3A-20A-28A <sup>12</sup>	-	3	See CA_3A-3A Bandwidth combination set 0 in Table 5.6A.1-3					80	0
		20			Yes	Yes	Yes		
		28		Yes	Yes	Yes	Yes		
CA_3C-20A-28A <sup>12</sup>	-	3	See CA_3C Bandwidth Combination Set 0 in Table 5.6A.1-1					80	0
		20			Yes	Yes	Yes		
		28		Yes	Yes	Yes	Yes		
CA_3A-20A-32A	CA_3A-20A	3		Yes	Yes	Yes	Yes	60	0
		20		Yes	Yes	Yes	Yes		
		32		Yes	Yes	Yes	Yes		
CA_3A-20A-42A	-	3		Yes	Yes	Yes	Yes	60	0
		20		Yes	Yes	Yes	Yes		
		42		Yes	Yes	Yes	Yes		
CA_3A-20A-43A	-	3		Yes	Yes	Yes		40	0
		20		Yes					
		43		Yes	Yes	Yes	Yes		
CA_3A-21A-28A	CA_3A-21A, CA_3A-28A <sup>6</sup> , CA_21A-28A	3		Yes	Yes	Yes	Yes	45	0
		21		Yes	Yes	Yes			
		28		Yes	Yes				
CA_3A-21A-42A	CA_3A-21A, CA_3A-42A, CA_21A-42A	3		Yes	Yes	Yes	Yes	55	0
		21		Yes	Yes	Yes			
		42		Yes	Yes	Yes	Yes		
CA_3A-21A-42C	CA_3A-21A, CA_3A-42A, CA_21A-42A	3		Yes	Yes	Yes	Yes	75	0
		21		Yes	Yes	Yes			
		42	See CA_42C Bandwidth combination set 0 in Table 5.6A.1-1						
	-	3		Yes	Yes	Yes	Yes	95	0

CA_3A-21A-42D		21		Yes	Yes	Yes			
		42	See CA_42D Bandwidth combination set 0 in Table 5.6A.1-1						
CA_3A-28A-38A	-	3		Yes	Yes	Yes	Yes	60	0
		28		Yes	Yes	Yes	Yes		
		38		Yes	Yes	Yes	Yes		
CA_3C-28A-38A	-	3	See CA_3C Bandwidth combination set 0 in Table 5.6A.1-1					80	0
		28		Yes	Yes	Yes	Yes		
		38		Yes	Yes	Yes	Yes		
CA_3A-28A-40A	CA_3A-28A <sup>6</sup>	3		Yes	Yes	Yes	Yes	60	0
		28		Yes	Yes	Yes	Yes		
		40		Yes	Yes	Yes	Yes		
CA_3A-28A-40C	CA_3A-28A <sup>6</sup>	3		Yes	Yes	Yes	Yes	80	0
		28		Yes	Yes	Yes	Yes		
		40	See CA_40C Bandwidth combination set 1 in Table 5.6A.1-1						
CA_3A-28A-40D	-	3		Yes	Yes	Yes	Yes	100	0
		28		Yes	Yes	Yes	Yes		
		40	See CA_40D Bandwidth Combination Set 0 in Table 5.6A.1-1						
CA_3A-28A-41A	CA_3A-41A	3		Yes	Yes	Yes	Yes	60	0
		28		Yes	Yes	Yes	Yes		
		41		Yes	Yes	Yes	Yes		
CA_3A-28A-41C	CA_3A-41A	3		Yes	Yes	Yes	Yes	80	0
		28		Yes	Yes	Yes	Yes		
		41	See CA_41C Bandwidth combination set 0 in Table 5.6A.1-1						
CA_3A-28A-42A	CA_3A-28A <sup>6</sup> , CA_3A-42A, CA_28A-42A	3		Yes	Yes	Yes	Yes	50	0
		28		Yes	Yes				
		42		Yes	Yes	Yes	Yes		
CA_3A-28A-42A-42A	-	3		Yes	Yes	Yes	Yes	70	0
		28		Yes	Yes				
		42	See CA_42A-42A Bandwidth combination set 0 in Table 5.6A.1-3						
CA_3A-28A-42C	CA_3A-28A <sup>6</sup> , CA_3A-42A, CA_28A-42A, CA_42C	3		Yes	Yes	Yes	Yes	70	0
		28		Yes	Yes				
		42	See CA_42C Bandwidth combination set 0 in Table 5.6A.1-1						
CA_3A-28A-42A-42C	CA_42C	3		Yes	Yes	Yes	Yes	90	0
		28		Yes	Yes				
		42	See CA_42A-42C Bandwidth combination set 0 in Table 5.6A.1-3						
CA_3A-28A-42C-42C	CA_42C	3		Yes	Yes	Yes	Yes	110	0
		28		Yes	Yes				
		42	See CA_42C-42C Bandwidth combination set 0 in Table 5.6A.1-3						
CA_3A-28A-42D	-	3		Yes	Yes	Yes	Yes	90	0
		28		Yes	Yes				
		42	See CA_42D Bandwidth Combination Set 0 in Table 5.6A.1-1						
CA_3A-32A-42A	-	3		Yes	Yes	Yes	Yes	55	0
		32		Yes	Yes	Yes	Yes		
		42		Yes	Yes	Yes	Yes		
CA_3A-32A-43A	-	3		Yes	Yes	Yes	Yes	55	0
		32		Yes	Yes	Yes	Yes		
		43		Yes	Yes	Yes	Yes		
CA_3A-32A-46A	-	3		Yes	Yes	Yes	Yes	60	0
		32		Yes	Yes	Yes	Yes		
		46					Yes		
CA_3A-32A-46C	-	3		Yes	Yes	Yes	Yes	80	0
		32		Yes	Yes	Yes	Yes		

		46	See CA_46C in Table 5.6A.1-1 of TS 36.101 Bandwidth Combination Set 0						
CA_3A-32A-46D	-	3		Yes	Yes	Yes	Yes		
		32		Yes	Yes	Yes	Yes		
		46	See CA_46D in Table 5.6A.1-1 of TS 36.101 Bandwidth Combination Set 0				100	0	
CA_3A-32A-46E	-	3		Yes	Yes	Yes	Yes		
		32		Yes	Yes	Yes	Yes		
		46	See CA_46E in Table 5.6A.1-1 of TS 36.101 Bandwidth Combination Set 0				120	0	
CA_3A-41A-42A	CA_3A-41A, CA_41A-42A, CA_3A-42A	3		Yes	Yes	Yes	Yes		
		41			Yes	Yes	Yes		
		42			Yes	Yes	Yes		
CA_3A-41A-42A-42A	-	3		Yes	Yes	Yes	Yes		
		41			Yes	Yes	Yes		
		42	See CA_42A-42A Bandwidth combination set 1 in Table 5.6A.1-3				80	0	
CA_3A-41A-42C	CA_3A-41A, CA_3A-42C, CA_3A-42A, CA_41A-42A, CA_41A-42C, CA_42C	3		Yes	Yes	Yes	Yes		
		41			Yes	Yes	Yes		
		42	See CA_42C Bandwidth combination set 1 in Table 5.6A.1-1				80	0	
CA_3A-41A-42A-42C	CA_42C	3		Yes	Yes	Yes	Yes		
		41			Yes	Yes	Yes		
		42	See CA_42A-42C Bandwidth combination set 1 in Table 5.6A.1-3				100	0	
CA_3A-41A-42C-42C	CA_42C	3		Yes	Yes	Yes	Yes		
		41			Yes	Yes	Yes		
		42	See CA_42C-42C Bandwidth combination set 1 in Table 5.6A.1-3				120	0	
CA_3A-41C-42A	CA_3A-41A, CA_3A-41C, CA_3A-42A, CA_41A-42A, CA_41C, CA_41C-42A	3		Yes	Yes	Yes	Yes		
		41	See CA_41C Bandwidth combination set 0 in Table 5.6A.1-1				80	0	
		42			Yes	Yes			Yes
CA_3A-41C-42C	CA_3A-41A, CA_3A-41C, CA_3A-42A, CA_3A-42C, CA_41A-42A, CA_41A-42C, CA_41C, CA_41C-42A, CA_42C	3		Yes	Yes	Yes	Yes		
		41	See CA_41C Bandwidth combination set 0 in Table 5.6A.1-1				100	0	
		42	See CA_42C Bandwidth combination set 1 in Table 5.6A.1-1						
CA_3A-42A-43A	-	3		Yes	Yes	Yes			
		42		Yes	Yes	Yes	Yes		
		43		Yes	Yes	Yes	Yes		
CA_4A-5A-12A	-	4		Yes	Yes	Yes	Yes		
		5		Yes	Yes				
		12		Yes	Yes				
CA_4A-5A-12A-12A	-	4		Yes	Yes	Yes	Yes		
		5		Yes	Yes				
		12	See CA_12A-12A Bandwidth Combination Set 0 in Table 5.6A.1-3				40	0	
CA_4A-5A-12B	-	4		Yes	Yes	Yes	Yes		
		5		Yes	Yes				
		12	See CA_12B Bandwidth Combination Set 0 in Table 5.6A.1-1				45	0	
CA_4A-4A-5A-12A	-	4	See CA_4A-4A Bandwidth Combination Set 0 in Table 5.6A.1-3				60	0	
		5		Yes	Yes				
		12		Yes	Yes				
	CA_4A-13A <sup>6</sup>	4		Yes	Yes	Yes	Yes	40	0

CA_4A-5A-13A		5			Yes	Yes					
		13				Yes					
CA_4A-5A-29A	-	4			Yes	Yes	Yes	Yes		40	0
		5			Yes	Yes					
		29			Yes	Yes					
CA_4A-5A-30A	-	4			Yes	Yes	Yes	Yes		40	0
		5			Yes	Yes					
		30			Yes	Yes					
CA_4A-4A-5A-30A	-	4	See CA_4A-4A Bandwidth Combination Set 0 in Table 5.6A.1-3							60	0
		5			Yes	Yes					
		30			Yes	Yes					
CA_4A-4A-5B-30A	-	4	See CA_4A-4A Bandwidth Combination Set 0 in Table 5.6A.1-3							70	0
		5	See CA_5B Bandwidth Combination Set 0 in Table 5.6A.1-1								
		30			Yes	Yes					
CA_4A-5B-30A	-	4			Yes	Yes	Yes	Yes		50	0
		5	See CA_5B Bandwidth Combination Set 0 in Table 5.6A.1-1								
		30			Yes	Yes					
CA_4A-7A-12A	-	4			Yes	Yes	Yes	Yes		40	0
		7			Yes	Yes	Yes	Yes			
		12			Yes	Yes					
		4			Yes	Yes	Yes	Yes		50	1
		7			Yes	Yes	Yes	Yes			
		12			Yes	Yes					
CA_4A-7A-28A	-	4			Yes	Yes	Yes	Yes		60	0
		7			Yes	Yes	Yes	Yes			
		28			Yes	Yes	Yes	Yes			
CA_4A-12A-30A	CA_4A-12A	4			Yes	Yes	Yes	Yes		40	0
		12			Yes	Yes					
		30			Yes	Yes					
CA_4A-4A-12A-30A	-	4	See CA_4A-4A Bandwidth Combination Set 0 in Table 5.6A.1-3							60	0
		12			Yes	Yes					
		30			Yes	Yes					
CA_4A-29A-30A	-	4			Yes	Yes	Yes	Yes		40	0
		29			Yes	Yes					
		30			Yes	Yes					
CA_4A-4A-29A-30A	-	4	See CA_4A-4A Bandwidth combination set 0 in Table 5.6A.1-3							60	0
		29			Yes	Yes					
		30			Yes	Yes					
CA_5A-7A-28A	-	5			Yes	Yes				50	0
		7				Yes	Yes	Yes			
		28			Yes	Yes	Yes	Yes			
CA_5A-7C-28A	-	5			Yes	Yes				70	0
		7	See CA_7C Bandwidth Combination Set 1 in Table 5.6A.1-1								
		28			Yes	Yes	Yes	Yes			
CA_5A-7A-46A	CA_5A-7A	5			Yes	Yes				50	0
		7				Yes	Yes	Yes			
		46						Yes			
CA_5A-7A-46C	CA_5A-7A	5			Yes	Yes				70	0
		7				Yes	Yes	Yes			
		46	See CA_46C Bandwidth combination set 0 in the Table 5.6A.1-1								
CA_5A-7A-46D	-	5			Yes	Yes				90	0
		7				Yes	Yes	Yes			
		46	See CA_46D Bandwidth combination set 0 in Table 5.6A.1-1								
	-	5			Yes	Yes				50	0



CA_5A-7A-66A		7			Yes	Yes	Yes				
		66		Yes	Yes	Yes	Yes				
CA_5A-7A-66A-66A	-	5			Yes	Yes			70	0	
		7			Yes	Yes	Yes				
		66	See CA_66A-66A Bandwidth Combination Set 0 in Table 5.6A.1-3								
CA_5A-7C-66A	-	5			Yes	Yes			70	0	
		7	See CA_7C Bandwidth Combination Set 1 in Table 5.6A.1-1								
		66			Yes	Yes	Yes	Yes			
CA_5A-7C-66A-66A	-	5			Yes	Yes			90	0	
		7	See CA_7C Bandwidth Combination Set 1 in Table 5.6A.1-1								
		66	See CA_66A-66A Bandwidth Combination Set 0 in Table 5.6A.1-3								
CA_5A-12A-46A	-	5			Yes	Yes			40	0	
		12			Yes	Yes					
		46					Yes				
CA_5A-12A-46C	-	5			Yes	Yes			60	0	
		12			Yes	Yes					
		46	See CA_46C Bandwidth Combination Set 0 in Table 5.6A.1-1								
CA_5A-12A-46D	-	5			Yes	Yes			80	0	
		12			Yes	Yes					
		46	See CA_46D Bandwidth Combination Set 0 in Table 5.6A.1-1								
CA_5A-12A-48A	-	5			Yes	Yes			40	0	
		12			Yes	Yes					
		48			Yes	Yes	Yes	Yes			
CA_5A-12A-48C	-	5			Yes	Yes			60	0	
		12			Yes	Yes					
		48	See CA_48C Bandwidth combination set 0 in the Table 5.6A.1-1								
CA_5A-12A-48D	-	5			Yes	Yes			80	0	
		12			Yes	Yes					
		48	See the CA_48D Bandwidth combination set 0 in the Table 5.6A.1-1								
CA_5A-30A-66A	-	5			Yes	Yes			40	0	
		30			Yes	Yes					
		66			Yes	Yes	Yes	Yes			
CA_5A-30A-66A-66A	-	5			Yes	Yes			60	0	
		30			Yes	Yes					
		66	See CA_66A-66A Bandwidth Combination Set 0 in Table 5.6A.1-3								
CA_5B-30A-66A	-	5	See CA_5B Bandwidth Combination Set 0 in Table 5.6A.1-1							50	0
		30			Yes	Yes					
		66			Yes	Yes	Yes	Yes			
CA_5B-30A-66A-66A	-	5	See CA_5B Bandwidth Combination Set 0 in Table 5.6A.1-1							70	0
		30			Yes	Yes					
		66	See CA_66A-66A Bandwidth Combination Set 0 in Table 5.6A.1-3								
CA_5A-46A-66A	-	5			Yes	Yes			50	0	
		46						Yes			
		66			Yes	Yes	Yes	Yes			
CA_5A-46E-66A	-	5			Yes	Yes			110	0	
		46	See CA_46E Bandwidth combination set 0 in Table 5.6A.1-1								
		66			Yes	Yes	Yes	Yes			
CA_5A-46A-66A-66A	-	5			Yes	Yes			70	0	
		46						Yes			
		66	See CA_66A-66A Bandwidth combination set 0 in Table 5.6A.1-3								
	-	5			Yes	Yes			90	0	

CA_5A-46C-66A-66A		46	See CA_46C Bandwidth combination set 0 in Table 5.6A.1-1						
		66	See CA_66A-66A Bandwidth combination set 0 in Table 5.6A.1-3						
CA_5A-46D-66A-66A	-	5		Yes	Yes		110	0	
		46	See CA_46D Bandwidth combination set 0 in Table 5.6A.1-1						
		66	See CA_66A-66A Bandwidth combination set 0 in Table 5.6A.1-3						
CA_5A-46E-66A-66A	-	5		Yes	Yes		130	0	
		46	See CA_46E Bandwidth combination set 0 in Table 5.6A.1-1						
		66	See CA_66A-66A Bandwidth combination set 0 in Table 5.6A.1-3						
CA_7A-8A-20A	-	7			Yes	Yes	Yes	40	0
		8	Yes	Yes	Yes				
		20		Yes	Yes				
CA_7A-8A-38A <sup>13</sup>	-	7			Yes	Yes	Yes	50	0
		8		Yes	Yes				
		38		Yes	Yes	Yes	Yes		
CA_7A-8A-40A	-	7		Yes	Yes	Yes	Yes	50	0
		8		Yes	Yes				
		40		Yes	Yes	Yes	Yes		
CA_5A-12A-66A	-	5		Yes	Yes		40	0	
		12		Yes	Yes				
		66		Yes	Yes	Yes			Yes
CA_5A-40A-41A	-	5		Yes	Yes		50	0	
		40			Yes				Yes
		41							Yes
CA_5A-46C-66A	-	5		Yes	Yes		70	0	
		46	See CA_46C Bandwidth Combination Set 0 in Table 5.6A.1-1						
		66		Yes	Yes	Yes			Yes
CA_5A-46D-66A	CA_5A-46A CA_5A-66A	5		Yes	Yes		90	0	
		46	See CA_46D Bandwidth Combination Set 0 in Table 5.6A.1-1						
		66		Yes	Yes	Yes			Yes
CA_5A-48A-66A	CA_48A-66A CA_5A-66A CA_5A-48A	5		Yes	Yes		50	0	
		48		Yes	Yes	Yes			Yes
		66		Yes	Yes	Yes			Yes
CA_5A-48A-66A-66A	CA_48A-66A CA_5A-66A CA_5A-48A	5		Yes	Yes		70	0	
		48		Yes	Yes	Yes			Yes
		66	See CA_66A-66A Bandwidth Combination Set 0 in Table 5.6A.1-3						
CA_5A-48C-66A	CA_48A-66A CA_5A-66A CA_5A-48A	5		Yes	Yes		70	0	
		48	See CA_48C Bandwidth combination set 0 in Table 1.6A.1-1						
		66	Yes	Yes	Yes	Yes			Yes
CA_5A-48C-66A-66A	CA_48A-66A CA_5A-66A CA_5A-48A	5		Yes	Yes		90	0	
		48	See CA_48C Bandwidth combination set 0 in Table 5.6A.1-1						
		66	See CA_66A-66A Bandwidth Combination Set 0 in Table 5.6A.1-3						
CA_5A-48D-66A	CA_48A-66A CA_5A-48A	5		Yes	Yes		90	0	
		48	See CA_48D Bandwidth combination set 0 in Table 5.6A.1-1						
		66	Yes	Yes	Yes	Yes			Yes
CA_5A-48D-66A-66A	CA_48A-66A CA_5A-66A CA_5A-48A	5		Yes	Yes		110	0	
		48	See CA_48D Bandwidth combination set 0 in Table 5.6A.1-1						
		66	See CA_66A-66A Bandwidth Combination Set 0 in Table 5.6A.1-3						
CA_7A-8A-40C	-	7		Yes	Yes	Yes	70	0	
		8		Yes	Yes				

		40	See CA_40C Bandwidth combination set 1 in Table 5.6A.1-1							
CA_7A-12A-66A	-	7		Yes	Yes	Yes	Yes	50	0	
		12		Yes	Yes					
		66		Yes	Yes	Yes	Yes			
CA_7A-12B-66A	-	7		Yes	Yes	Yes	Yes	55	0	
		12	See CA_12B Bandwidth combination set 0 in Table 5.6A.1-1							
		66		Yes	Yes	Yes	Yes			
CA_7A-13A-66A	-	7		Yes	Yes	Yes	Yes	50	0	
		13		Yes	Yes					
		66		Yes	Yes	Yes	Yes			
CA_7C-13A-66A	-	7	See CA_7C Bandwidth combination set 1 in Table 5.6A.1-1						70	0
		13		Yes	Yes					
		66		Yes	Yes	Yes	Yes			
CA_7A-20A-28A <sup>12</sup>	-	7		Yes	Yes	Yes	Yes	60	0	
		20			Yes	Yes	Yes			
		28		Yes	Yes	Yes	Yes			
CA_7A-20A-32A	CA_7A-20A	7			Yes	Yes	Yes	60	0	
		20		Yes	Yes	Yes	Yes			
		32		Yes	Yes	Yes	Yes			
CA_7A-20A-38A <sup>9</sup>	-	7			Yes	Yes	Yes	60	0	
		20		Yes	Yes	Yes	Yes			
		38		Yes	Yes	Yes	Yes			
CA_7A-26A-66A	-	7			Yes	Yes	Yes	55	0	
		26	Yes	Yes	Yes	Yes				
		66	Yes	Yes	Yes	Yes				
CA_7A-28A-40A	-	7		Yes	Yes	Yes	Yes	60	0	
		28		Yes	Yes	Yes	Yes			
		40		Yes	Yes	Yes	Yes			
CA_7A-28A-40C	-	7		Yes	Yes	Yes	Yes	80	0	
		28		Yes	Yes	Yes	Yes			
		40	See CA_40C Bandwidth combination set 0 in Table 5.6A.1-1							
CA_7A-20A-42A	-	7			Yes	Yes	Yes	60	0	
		20		Yes	Yes	Yes	Yes			
		42		Yes	Yes	Yes	Yes			
CA_7A-28A-38A <sup>14</sup>	-	7			Yes	Yes	Yes	60	0	
		28		Yes	Yes	Yes	Yes			
		38		Yes	Yes	Yes	Yes			
CA_7A-29A-66A	-	7		Yes	Yes	Yes	Yes	50	0	
		29		Yes	Yes					
		66		Yes	Yes	Yes	Yes			
CA_7A-7A-29A-66A	-	7	See CA_7A-7A Bandwidth combination set 1 in table 5.6A.1-3						70	0
		29		Yes	Yes					
		66		Yes	Yes	Yes	Yes			
CA_7C-29A-66A	-	7	See CA_7C Bandwidth combination set 2 in table 5.6A.1-1						70	0
		29		Yes	Yes					
		66		Yes	Yes	Yes	Yes			
CA_7A-30A-66A	-	7		Yes	Yes	Yes	Yes	50	0	
		30		Yes	Yes					
		66		Yes	Yes	Yes	Yes			
CA_7A-32A-46A	-	7			Yes	Yes	Yes	60	0	
		32		Yes	Yes	Yes	Yes			
		46					Yes			
CA_7A-32A-46C	-	7			Yes	Yes	Yes	80	0	
		32		Yes	Yes	Yes	Yes			
		46	See CA_46C in Table 5.6A.1-1 of TS 36.101 Bandwidth Combination Set 0							

CA_7A-32A-46D	-	7			Yes	Yes	Yes	100	0
		32		Yes	Yes	Yes	Yes		
		46	See CA_46D in Table 5.6A.1-1 of TS 36.101 Bandwidth Combination Set 0						
CA_7A-32A-46E	-	7			Yes	Yes	Yes	120	0
		32		Yes	Yes	Yes	Yes		
		46	See CA_46E in Table 5.6A.1-1 of TS 36.101 Bandwidth Combination Set 0						
CA_7A-46A-66A	-	7		Yes	Yes	Yes	Yes	60	0
		46		Yes			Yes		
		66		Yes	Yes	Yes	Yes		
CA_8A-11A-28A	-	8		Yes	Yes			40	0
		11		Yes	Yes				
		28		Yes	Yes	Yes	Yes		
CA_8A-11A-42A	-	8		Yes	Yes			40	0
		11		Yes	Yes				
		42		Yes	Yes	Yes	Yes		
CA_8A-11A-42C	-	8		Yes	Yes			60	0
		11		Yes	Yes				
		42	See CA_42C Bandwidth Combination Set 0 in Table 5.6A.1-1						
CA_8A-20A-28A <sup>15</sup>	-	8		Yes	Yes			50	0
		20		Yes	Yes	Yes	Yes		
		28		Yes	Yes	Yes	Yes		
CA_8A-28A-41A	-	8		Yes	Yes			50	0
		28		Yes	Yes	Yes	Yes		
		41		Yes	Yes	Yes	Yes		
CA_8A-39A-41A	-	8		Yes	Yes			50	0
		39		Yes	Yes	Yes	Yes		
		41					Yes		
CA_12A-30A-66A	-	12		Yes	Yes			40	0
		30		Yes	Yes				
		66		Yes	Yes	Yes	Yes		
CA_12A-30A-66A-66A	-	12		Yes	Yes			60	0
		30		Yes	Yes				
		66	See CA_66A-66A Bandwidth Combination Set 0 in Table 5.6A.1-3						
CA_13A-46A-66A	-	13		Yes	Yes			50	0
		46					Yes		
		66		Yes	Yes	Yes	Yes		
CA_13A-46A-66A-66A	-	13		Yes	Yes			70	0
		46					Yes		
		66	See CA_66A-66A Bandwidth Combination Set 0 in Table 5.6A.1-3						
CA_13A-46C-66A	-	13		Yes	Yes			70	0
		46	See CA_46C Bandwidth Combination Set 0 in Table 5.6A.1-1						
		66		Yes	Yes	Yes	Yes		
CA_13A-46C-66A-66A	-	13		Yes	Yes			90	0
		46	See CA_46C Bandwidth Combination Set 0 in Table 5.6A.1-1						
		66	See CA_66A-66A Bandwidth Combination Set 0 in Table 5.6A.1-3						
CA_13A-46D-66A	CA_13A-66A	13		Yes	Yes			90	0
		46	See CA_46D Bandwidth Combination Set 0 in Table 5.6A.1-1						
		66		Yes	Yes	Yes	Yes		
CA_13A-46D-66A-66A	-	13		Yes	Yes			110	0
		46	See CA_46D Bandwidth Combination Set 0 in Table 5.6A.1-1						
		66	See CA_66A-66A Bandwidth Combination Set 0 in Table 5.6A.1-3						
	-	13		Yes	Yes			110	0

CA_13A-46E-66A		46	See CA_46E Bandwidth Combination Set 0 in Table 5.6A.1-1						
		66		Yes	Yes	Yes			Yes
CA_13A-48A-66A	CA_13A-48A CA_13A-66A CA_48A-66A	13		Yes	Yes		50	0	
		48		Yes	Yes	Yes			Yes
		66		Yes	Yes	Yes			Yes
CA_13A-48A-48A-66A	CA_13A-48A CA_13A-66A CA_48A-66A	13		Yes	Yes		70	0	
		48	See CA_48A-48A Bandwidth Combination Set 0 in Table 5.6A.1-3						
		66		Yes	Yes	Yes			Yes
CA_13A-48C-66A	CA_48A-66A CA_13A-66A CA_13A-48A	13		Yes	Yes		70	0	
		48	See CA_48C Bandwidth Combination Set 0 in Table 5.6A.1-1						
		66		Yes	Yes	Yes			Yes
CA_13A-48C-66A-66A	CA_48A-66A CA_13A-66A CA_13A-48A	13		Yes	Yes		90	0	
		48	See CA_48C Bandwidth Combination Set 0 in Table 5.6A.1-1						
		66	See CA_66A-66A Bandwidth Combination Set 0 in Table 5.6A.1-3						
CA_13A-48D-66A	CA_48A-66A CA_13A-48A	13		Yes	Yes		90	0	
		48	See CA_48D Bandwidth Combination Set 0 in Table 5.6A.1-1						
		66		Yes	Yes	Yes			Yes
CA_13A-48D-66A-66A	CA_48A-66A CA_13A-66A CA_13A-48A	13		Yes	Yes		110	0	
		48	See CA_48D Bandwidth Combination Set 0 in Table 5.6A.1-1						
		66	See CA_66A-66A Bandwidth Combination Set 0 in Table 5.6A.1-3						
CA_13A-48D-66A	-	13		Yes	Yes		90	0	
		48	See CA_48D Bandwidth Combination Set 0 in Table 5.6A.1-1						
		66		Yes	Yes	Yes			Yes
CA_13A-48E-66A	-	13		Yes	Yes		110	0	
		48	See CA_48E Bandwidth combination set 0 in Table 5.6A.1-1						
		66		Yes	Yes	Yes			Yes
CA_13A-48A-48C-66A	-	13		Yes	Yes		90	0	
		48	See CA_48A-48C Bandwidth Combination Set 0 in Table 5.6A.1-3						
		66		Yes	Yes	Yes			Yes
CA_13A-48A-66A-66A	CA_48A-66A CA_13A-66A CA_13A-48A	13		Yes	Yes		70	0	
		48		Yes	Yes	Yes			Yes
		66	See CA_66A-66A Bandwidth Combination Set 0 in Table 5.6A.1-3						
CA_13A-48A-66B	-	13		Yes	Yes		50	0	
		48		Yes	Yes	Yes			Yes
		66	See CA_66B Bandwidth combination set 0 in Table 5.6A.1-1						
CA_13A-48A-66C	-	13		Yes	Yes		70	0	
		48		Yes	Yes	Yes			Yes
		66	See CA_66C Bandwidth combination set 0 in Table 5.6A.1-1						
CA_14A-30A-66A	CA_14A-30A CA_14A-66A	14		Yes	Yes		40	0	
		30		Yes	Yes				
		66		Yes	Yes	Yes			Yes
CA_14A-30A-66A-66A	CA_14A-30A CA_14A-66A	14		Yes	Yes		60	0	
		30		Yes	Yes				
		66	See CA_66A-66A Bandwidth combination set 0 in Table 5.6A.1-3						
CA_19A-21A-42A	CA_19A-21A, CA_19A-42A <sup>6</sup> , CA_21A-42A	19		Yes	Yes	Yes	50	0	
		21		Yes	Yes	Yes			
		42		Yes	Yes	Yes			Yes
CA_19A-21A-42C	CA_19A-21A, CA_19A-42A <sup>6</sup> , CA_21A-42A	19		Yes	Yes	Yes	70	0	
		21		Yes	Yes	Yes			
		42	See CA_42C Bandwidth combination set 0 in Table 5.6A.1-1						

CA_20A-32A-42A	-	20			Yes				45	0		
		32			Yes	Yes	Yes	Yes				
		42			Yes	Yes	Yes	Yes				
CA_20A-32A-43A	-	20			Yes				45	0		
		32			Yes	Yes	Yes	Yes				
		43			Yes	Yes	Yes	Yes				
CA_20A-38A-40A		20			Yes	Yes	Yes		55	0		
		38				Yes	Yes	Yes				
		40				Yes	Yes	Yes				
CA_20A-38A-40A-40A	-	20			Yes	Yes	Yes		75	0		
		38				Yes	Yes	Yes				
		40	See CA_40A-40A Bandwidth Combination Set 1 in Table 5.6A.1-3									
CA_20A-38A-40C	-	20			Yes	Yes	Yes		75	0		
		38				Yes	Yes	Yes				
		40	See CA_40C Bandwidth Combination Set 1 in Table 5.6A.1-1									
CA_20A-38A-40D	-	20			Yes	Yes	Yes		95	0		
		38				Yes	Yes	Yes				
		40	See CA_40D Bandwidth Combination Set 1 in Table 5.6A.1-1									
CA_21A-28A-42A	CA_21A-28A, CA_21A-42A, CA_28A-42A	21			Yes	Yes	Yes		45	0		
		28			Yes	Yes						
		42			Yes	Yes	Yes	Yes				
CA_21A-28A-42C	CA_21A-28A, CA_21A-42A, CA_28A-42A	21			Yes	Yes	Yes		65	0		
		28			Yes	Yes						
		42	See CA_42C Bandwidth combination set 0 in Table 5.6A.1-1									
CA_25A-26A-41A	-	25		Yes	Yes	Yes	Yes	Yes	55	0		
		26	Yes	Yes	Yes	Yes	Yes					
		41		Yes	Yes	Yes	Yes	Yes				
CA_25A-25A-26A-41A	-	25	See CA_25A-25A Bandwidth Combination Set 1 in Table 5.6A.1-3								65	0
		26		Yes	Yes							
		41			Yes	Yes	Yes	Yes				
CA_25A-25A-26A-41C	-	25	See CA_25A-25A Bandwidth Combination Set 1 in Table 5.6A.1-3								85	0
		26		Yes	Yes							
		41	See CA_41C Bandwidth Combination Set 1 in Table 5.6A.1-1									
CA_25A-26A-41C	-	25		Yes	Yes	Yes	Yes	Yes	75	0		
		26	Yes	Yes	Yes	Yes	Yes					
		41	See CA_41C Bandwidth Combination Set 0 in Table 5.6A.1-1									
CA_25A-25A-26A-41D	-	25	See CA_25A-25A Bandwidth Combination Set 1 in Table 5.6A.1-3								105	0
		26		Yes	Yes							
		41	See CA_41D Bandwidth combination set 0 in Table 5.6A.1-1									
CA_25A-25A-26A-41E	-	25	See CA_25A-25A Bandwidth Combination Set 1 in Table 5.6A.1-3								125	0
		26		Yes	Yes							
		41	See CA_41E Bandwidth combination set 0 in Table 5.6A.1-1									
CA_25A-25A-26A-41F	-	25	See CA_25A-25A Bandwidth Combination Set 1 in Table 5.6A.1-3								145	0
		26		Yes	Yes							
		41	See CA_41F Bandwidth combination set 0 in Table 5.6A.1-1									
CA_28A-41A-42A	CA_41A-42A	28			Yes	Yes			50	0		
		41				Yes	Yes	Yes				
		42				Yes	Yes	Yes				
CA_28A-41A-42A-42A	-	28			Yes	Yes			70	0		
		41				Yes	Yes	Yes				

		42	See CA_42A-42A Bandwidth Combination Set 1 in Table 5.6A.1-3							
CA_28A-41A-42C	CA_41A-42A, CA_42C	28		Yes	Yes			70	0	
		41		Yes	Yes	Yes	Yes			
		42	See CA_42C Bandwidth Combination Set 1 in Table 5.6A.1-1							
CA_28A-41A-42A-42C	CA_42C	28		Yes	Yes			90	0	
		41		Yes	Yes	Yes	Yes			
		42	See CA_42A-42C Bandwidth Combination Set 1 in Table 5.6A.1-3							
CA_28A-41A-42C-42C	CA_42C	28		Yes	Yes			110	0	
		41		Yes	Yes	Yes	Yes			
		42	See CA_42C-42C Bandwidth Combination Set 1 in Table 5.6A.1-3							
CA_28A-41C-42A	CA_41A-42A	28		Yes	Yes			70	0	
		41	See CA_41C Bandwidth Combination Set 0 in Table 5.6A.1-1							
		42		Yes	Yes	Yes	Yes			
CA_28A-41C-42C	CA_42C	28		Yes	Yes			90	0	
		41	See CA_41C Bandwidth combination set 0 in Table 5.6A.1-1							
		42	See CA_42C Bandwidth combination set 1 in Table 5.6A.1-1							
CA_29A-30A-66A	-	29		Yes	Yes			40	0	
		30		Yes	Yes					
		66		Yes	Yes	Yes	Yes			
CA_29A-30A-66A-66A	-	29		Yes	Yes			60	0	
		30		Yes	Yes					
		66	See CA_66A-66A Bandwidth combination set 0 in Table 5.6A.1-3							
CA_29A-46A-66A	-	29		Yes	Yes			50	0	
		46					Yes			
		66		Yes	Yes	Yes	Yes			
CA_29A-66A-70A	-	29		Yes	Yes			45	0	
		66		Yes	Yes	Yes	Yes			
		70		Yes	Yes	Yes				
CA_29A-66A-66A-70A	-	29		Yes	Yes			65	0	
		66	See CA_66A-66A Bandwidth combination set 0 in Table 5.6A.1-3							
		70		Yes	Yes	Yes				
CA_29A-66A-70C	-	29		Yes	Yes			55	0	
		66		Yes	Yes	Yes	Yes			
		70	See CA_70C Bandwidth combination set 0 in Table 5.6A.1-1							
CA_29A-66A-66A-70C	-	29		Yes	Yes			75	0	
		66	See the CA_66A-66A Bandwidth combination set 0 in Table 5.6A.1-3							
		70	See the CA_70C Bandwidth combination set 0 in Table 5.6A.1-1							
CA_29A-66C-70A	-	29		Yes	Yes			65	0	
		66	See CA_66C Bandwidth combination set 0 in Table 5.6A.1-1							
		70		Yes	Yes	Yes				
CA_29A-66C-70C	-	29		Yes	Yes			75	0	
		66	See the CA_66C Bandwidth combination set 0 in Table 5.6A.1-1							
		70	See the CA_70C Bandwidth combination set 0 in Table 5.6A.1-1							
CA_32A-42A-43A	-	32		Yes	Yes	Yes	Yes	60	0	
		42		Yes	Yes	Yes	Yes			
		43		Yes	Yes	Yes	Yes			
CA_46A-48A-66A	CA_48A-66A	46					Yes	60	0	
		48		Yes	Yes	Yes	Yes			

		66			Yes	Yes	Yes	Yes			
CA_46A-48A-71A	-	46							Yes		
		48			Yes	Yes	Yes	Yes			
		71			Yes	Yes	Yes	Yes			
CA_46C-48A-48A-71A	-	46	See CA_46C Bandwidth combination set 0 in Table 5.6A.1-1							100	0
		48	See CA_48A-48A Bandwidth combination set 0 in Table 5.6A.1-3								
		71			Yes	Yes	Yes	Yes			
CA_46A-48C-66A	CA_48A-66A	46							Yes		
		48	See the CA_48C Bandwidth combination set 0 in Table 5.6A.1-1							80	0
		66			Yes	Yes	Yes	Yes			
46							Yes				
CA_46A-48D-66A	-	48	See the CA_48D Bandwidth combination set 0 in Table 5.6A.1-1							100	0
		66			Yes	Yes	Yes	Yes			
		46							Yes		
CA_46A-48E-66A	-	48	See the CA_48E Bandwidth combination set 0 in Table 5.6A.1-1							120	0
		66			Yes	Yes	Yes	Yes			
		46							Yes		
CA_46C-48A-66A	CA_48A-66A	46	See the CA_46C Bandwidth combination set 0 in Table 5.6A.1-1							80	0
		48			Yes	Yes	Yes	Yes			
		66			Yes	Yes	Yes	Yes			
CA_46C-48C-66A	CA_48A-66A	46	See the CA_46C Bandwidth combination set 0 in Table 5.6A.1-1							100	0
		48	See the CA_48C Bandwidth combination set 0 in Table 5.6A.1-1								
		66			Yes	Yes	Yes	Yes			
CA_46C-48D-66A	-	46	See the CA_46C Bandwidth combination set 0 in Table 5.6A.1-1							120	0
		48	See the CA_48D Bandwidth combination set 0 in Table 5.6A.1-1								
		66			Yes	Yes	Yes	Yes			
CA_46C-48E-66A	-	46	See the CA_46C Bandwidth combination set 0 in Table 5.6A.1-1							140	0
		48	See the CA_48E Bandwidth combination set 0 in Table 5.6A.1-1								
		66			Yes	Yes	Yes	Yes			
CA_46D-48A-66A	CA_48A-66A	46	See the CA_46D Bandwidth combination set 0 in Table 5.6A.1-1							100	0
		48			Yes	Yes	Yes	Yes			
		66			Yes	Yes	Yes	Yes			
CA_46D-48C-66A	CA_48A-66A	46	See the CA_46D Bandwidth combination set 0 in Table 5.6A.1-1							120	0
		48	See the CA_48C Bandwidth combination set 0 in Table 5.6A.1-1								
		66			Yes	Yes	Yes	Yes			
CA_46E-48A-66A	-	46	See the CA_46E Bandwidth combination set 0 in Table 5.6A.1-1							120	0
		48			Yes	Yes	Yes	Yes			
		66			Yes	Yes	Yes	Yes			
CA_46E-48C-66A	-	46	See the CA_46E Bandwidth combination set 0 in Table 5.6A.1-1							140	0
		48	See the CA_48C Bandwidth combination set 0 in Table 5.6A.1-1								
		66			Yes	Yes	Yes	Yes			
CA_46A-48A-48A-71A	-	46							Yes		
		48	See CA_48A-48A Bandwidth combination set 0 in Table 5.6A.1-3							80	0
		71			Yes	Yes	Yes	Yes			
	-	46						Yes			



CA_46A-48C-71A		48	See CA_48C Bandwidth combination set 0 in Table 5.6A.1-1						
		71		Yes	Yes	Yes			Yes
CA_46C-48A-71A	-	46	See CA_46C Bandwidth combination set 0 in Table 5.6A.1-1				80	0	
		48		Yes	Yes	Yes			Yes
		71		Yes	Yes	Yes			Yes
CA_46C-48C-71A	-	46	See CA_46C Bandwidth combination set 0 in Table 5.6A.1-1				100	0	
		48	See CA_48C Bandwidth combination set 0 in Table 5.6A.1-1						
		71		Yes	Yes	Yes			Yes
CA_66A-70A-71A	-	66		Yes	Yes	Yes	Yes		
		70		Yes	Yes	Yes			
		71		Yes	Yes	Yes	Yes		
CA_66C-70A-71A	-	66	See the CA_66C Bandwidth combination set 0 in Table 5.6A.1-1				75	0	
		70		Yes	Yes	Yes			
		71		Yes	Yes	Yes			Yes
CA_66A-70C-71A	-	66	Yes				65	0	
		70	See the CA_70C Bandwidth combination set 0 in Table 5.6A.1-1						
		71		Yes	Yes	Yes			Yes
CA_66A-66A-70A-71A	-	66	See the CA_66A-66A Bandwidth combination set 0 in Table 5.6A.1-3				75	0	
		70		Yes	Yes	Yes			
		71		Yes	Yes	Yes			Yes
CA_66A-66A-70C-71A	-	66	See the CA_66A-66A Bandwidth combination set 0 in Table 5.6A.1-3				85	0	
		70	See the CA_70C Bandwidth combination set 0 in Table 5.6A.1-1						
		71		Yes	Yes	Yes			Yes
CA_66C-70C-71A	-	66	See the CA_66C Bandwidth combination set 0 in Table 5.6A.1-1				85	0	
		70	See the CA_70C Bandwidth combination set 0 in Table 5.6A.1-1						
		71		Yes	Yes	Yes			Yes

- NOTE 1: The CA Configuration refers to a combination of an operating band and a CA bandwidth class specified in Table 5.6A-1 (the indexing letter). Absence of a CA bandwidth class for an operating band implies support of all classes.
- NOTE 2: For each band combination, all combinations of indicated bandwidths belong to the set.
- NOTE 3: For the supported CC bandwidth combinations, the CC downlink and uplink bandwidths are equal.
- NOTE 4: A terminal which supports a DL CA configuration shall support all the lower order fallback DL CA combinations and it shall support at least one bandwidth combination set for each of the constituent lower order DL combinations containing all the bandwidths specified within each specific combination set of the upper order DL combination.
- NOTE 5: Uplink CA configurations are the configurations supported by the present release of specifications.
- NOTE 6: If the UE supports any uplink CA configuration for corresponding downlink CA configuration it shall support this uplink CA configuration.
- NOTE 7: UL carrier shall be supported in Band 3 only. Power imbalance between downlink carriers on Band 7 and Band 38 is assumed to be within [6dB].
- NOTE 8: UL carrier shall be supported in Band 20 only. Power imbalance between downlink carriers on Band 7 and Band 38 is assumed to be within [6dB].
- NOTE 9: UL carrier is only supported on Band 1 or Band 3 not Band 41 because the fall back mode 1UL/2DL CA\_1A-41A has the limitation that UL carrier is only supported on Band 1.
- NOTE 10: UL carrier is only supported on Band 1 or Band 42 not Band 41 because the fall back mode 1UL/2DL CA\_1A-41A has the limitation that UL carrier is only supported on Band 1.
- NOTE 11: UL carrier is only supported on Band 1 or Band 5 not Band 41 because the fall back mode 1UL/2DL CA\_1A-41A has the limitation that UL carrier is only supported on Band 1.
- NOTE 12: Power imbalance between downlink carriers on Band 20 and Band 28 is assumed to be within [6dB].
- NOTE 13: UL carrier shall be supported in Band 8 only. Power imbalance between downlink carriers on Band 7 and Band 38 is assumed to be within [6dB].
- NOTE 14: UL carrier shall be supported in Band 28 only. Power imbalance between downlink carriers on Band 7 and Band 38 is assumed to be within [6dB].
- NOTE 15: Power imbalance between downlink carriers on Band 20 and Band 28 is assumed to be within [6dB].
- NOTE 16: UL carrier shall be supported in Band 1 only. Power imbalance between downlink carriers on Band 7 and Band 38 is assumed to be within [6dB].

**Table 5.6A.1-2b: E-UTRA CA configurations and bandwidth combination sets defined for inter-band CA (four bands)**

E-UTRA CA configuration / Bandwidth combination set										
E-UTRA CA Configuration	Uplink CA configurations (NOTE 5)	E-UTRA Bands	1.4 MHz	3 MHz	5 MHz	10 MHz	15 MHz	20 MHz	Maximum aggregated bandwidth [MHz]	Bandwidth combination set
CA_1A-3A-5A-7A	CA_1A-3A, CA_1A-5A <sup>6</sup> , CA_1A-7A, CA_3A-5A, CA_3A-7A, CA_5A-7A	1			Yes	Yes	Yes	Yes	70	0
		3				Yes	Yes	Yes		
		5			Yes	Yes				
		7			Yes	Yes	Yes	Yes		
		1			Yes	Yes	Yes	Yes	70	1
		3			Yes	Yes	Yes	Yes		
		5			Yes	Yes				
7				Yes	Yes	Yes	Yes			
CA_1A-3A-3A-5A-7A	-	1			Yes	Yes	Yes	Yes	85	0
		3	See CA_3A-3A Bandwidth Combination Set 0 in Table 5.6A.1-3							
		5			Yes	Yes				
		7				Yes	Yes	Yes		
CA_1A-3A-5A-7A-7A	CA_1A-3A, CA_1A-5A <sup>6</sup> , CA_1A-7A, CA_3A-5A, CA_3A-7A, CA_5A-7A	1			Yes	Yes	Yes	Yes	90	0
		3			Yes	Yes	Yes	Yes		
		5			Yes	Yes				
		7	See CA_7A-7A Bandwidth Combination Set 3 in Table 5.6A.1-3							
CA_1A-3A-5A-28A	-	1			Yes	Yes	Yes		65	0
		3			Yes	Yes	Yes	Yes		
		5			Yes	Yes				
		28			Yes	Yes	Yes	Yes		
CA_1A-3A-5A-40A	CA_1A-3A, CA_1A-5A <sup>6</sup> , CA_3A-5A	1			Yes	Yes	Yes	Yes	70	0
		3			Yes	Yes	Yes	Yes		
		5			Yes	Yes				
		40				Yes	Yes	Yes		
CA_1A-3A-5A-41A <sup>8</sup>	-	1			Yes	Yes	Yes	Yes	70	0
		3			Yes	Yes	Yes	Yes		
		5			Yes	Yes				
		41						Yes		
CA_1A-3A-7A-7A-26A	CA_1A-3A, CA_1A-7A, CA_1A-26A, CA_3A-7A, CA_3A-26A, CA_7A-26A	1			Yes	Yes	Yes	Yes	95	0
		3			Yes	Yes	Yes	Yes		
		7	See the CA_7A-7A Bandwidth combination set 3 in Table 5.6A.1-3							
		26			Yes	Yes	Yes			
CA_1A-3A-7A-8A	CA_1A-3A, CA_1A-7A, CA_1A-8A, CA_3A-7A, CA_3A-8A, CA_7A-8A	1			Yes	Yes	Yes	Yes	70	0
		3			Yes	Yes	Yes	Yes		
		7				Yes	Yes	Yes		
		8			Yes	Yes				
		1			Yes	Yes	Yes	Yes	70	1
		3			Yes	Yes	Yes	Yes		
		7			Yes	Yes	Yes	Yes		
		8			Yes	Yes				
1			Yes	Yes	Yes	Yes				
CA_1A-3C-7A-8A	-	3	See the CA_3C Bandwidth combination set 0 in Table 5.6A.1-1						90	0
		7			Yes	Yes	Yes	Yes		
		8			Yes	Yes				
		1			Yes	Yes	Yes	Yes		
CA_1A-3A-3A-7A-8A	CA_1A-3A, CA_1A-7A, CA_1A-8A, CA_3A-7A, CA_3A-8A, CA_7A-8A	3	See the CA_3A-3A Bandwidth combination set 0 in Table 5.6A.1-3						90	0
		7			Yes	Yes	Yes	Yes		
		8			Yes	Yes				
		1			Yes	Yes	Yes	Yes		
CA_1A-3A-7A-7A-8A		1			Yes	Yes	Yes	Yes	90	0
		3			Yes	Yes	Yes	Yes		
		7	See the CA_7A-7A Bandwidth combination set 1 in Table 5.6A.1-3							

	CA_1A-3A, CA_1A-7A, CA_1A-8A, CA_3A-7A, CA_3A-8A, CA_7A-8A	8			Yes	Yes					
CA_1A-3A-3A-7A-7A-8A	CA_1A-3A, CA_1A-7A, CA_1A-8A, CA_3A-7A, CA_3A-8A, CA_7A-8A	1			Yes	Yes	Yes	Yes	110	0	
		3	See the CA_3A-3A Bandwidth combination set 0 in Table 5.6A.1-3								
		7	See the CA_7A-7A Bandwidth combination set 1 in Table 5.6A.1-3								
		8			Yes	Yes					
CA_1A-3A-7A-20A	CA_1A-3A, CA_1A-7A, CA_1A-20A, CA_3A-7A, CA_3A-20A, CA_7A-20A	1			Yes	Yes	Yes	Yes	80	0	
		3			Yes	Yes	Yes	Yes			
		7				Yes	Yes	Yes			
		20			Yes	Yes	Yes	Yes			
		1			Yes	Yes	Yes	Yes	80	1	
		3			Yes	Yes	Yes	Yes			
		7			Yes	Yes	Yes	Yes			
		20			Yes	Yes	Yes	Yes			
CA_1A-3A-7C-20A	-	1			Yes	Yes	Yes	Yes	100	0	
		3			Yes	Yes	Yes	Yes			
		7	See CA_7C Bandwidth combination set 1 in Table 5.6A.1-1								
		20			Yes	Yes	Yes	Yes			
CA_1A-3C-7A-20A	-	1			Yes	Yes	Yes	Yes	100	0	
		3	See CA_3C Bandwidth combination set 0 in Table 5.6A.1-1								
		7			Yes	Yes	Yes	Yes			
		20			Yes	Yes	Yes	Yes			
CA_1A-3A-3A-7A-20A	-	1			Yes	Yes	Yes	Yes	100	0	
		3	See CA_3A-3A Bandwidth combination set 0 in Table 5.6A.1-3								
		7			Yes	Yes	Yes	Yes			
		20			Yes	Yes	Yes	Yes			
CA_1A-3A-7A-7A-20A	-	1			Yes	Yes	Yes	Yes	100	0	
		3			Yes	Yes	Yes	Yes			
		7	See CA_7A-7A Bandwidth Combination Set 3 in Table 5.6A.1-3								
		20			Yes	Yes	Yes	Yes			
CA_1A-3A-7A-26A	CA_1A-3A, CA_1A-7A, CA_1A-26A, CA_3A-7A, CA_3A-26A, CA_7A-26A	1			Yes	Yes	Yes	Yes	75	0	
		3			Yes	Yes	Yes	Yes			
		7				Yes	Yes	Yes			
		26			Yes	Yes	Yes				
CA_1A-3A-7A-28A	CA_1A-3A, CA_1A-7A, CA_1A-28A, CA_3A-7A, CA_3A-28A <sup>6</sup> , CA_7A-28A	1			Yes	Yes	Yes	Yes	80	0	
		3				Yes	Yes	Yes			
		7				Yes	Yes	Yes			
		28				Yes	Yes	Yes			
		1			Yes	Yes	Yes	Yes	80	1	
		3			Yes	Yes	Yes	Yes			
		7				Yes	Yes	Yes			
		28			Yes	Yes	Yes	Yes			
CA_1A-3C-7A-28A	CA_3C	1			Yes	Yes	Yes	Yes	100	0	
		3	See CA_3C Bandwidth combination set 0 in Table 5.6A.1-1								
		7				Yes	Yes	Yes			
		28			Yes	Yes	Yes	Yes			
CA_1A-3A-7C-28A	CA_1A-3A, CA_1A-7A, CA_1A-28A, CA_3A-7A, CA_3A-28A <sup>6</sup> , CA_7A-28A, CA_7C	1			Yes	Yes	Yes	Yes	100	0	
		3				Yes	Yes	Yes			
		7	See CA_7C Bandwidth Combination Set 2 in Table 5.6A.1-1								
		28				Yes	Yes	Yes			

CA_1A-3C-7C-28A	CA_3C CA_7C	1		Yes	Yes	Yes	Yes	120	0	
		3	See CA_3C Bandwidth combination set 0 in Table 5.6A.1-1							
		7	See CA_7C Bandwidth Combination Set 2 in Table 5.6A.1-1							
		28		Yes	Yes	Yes	Yes			
CA_1A-1A-3A-7A-28A	-	1	See CA_1A-1A Bandwidth Combination Set 0 in Table 5.6A.1-3						100	0
		3		Yes	Yes	Yes	Yes			
		7			Yes	Yes	Yes			
		28		Yes	Yes	Yes	Yes			
CA_1A-1A-3A-7C-28A	CA_7C	1	See CA_1A-1A Bandwidth Combination Set 0 in Table 5.6A.1-3						120	0
		3		Yes	Yes	Yes	Yes			
		7	See CA_7C Bandwidth combination set 2 in Table 5.6A.1-1							
		28		Yes	Yes	Yes	Yes			
CA_1A-1A-3C-7A-28A	CA_3C	1	See CA_1A-1A Bandwidth Combination Set 0 in Table 5.6A.1-3						120	0
		3	See CA_3C Bandwidth combination set 0 in Table 5.6A.1-1							
		7			Yes	Yes	Yes	Yes		
		28		Yes	Yes	Yes	Yes			
CA_1A-1A-3C-7C-28A	CA_3C CA_7C	1	See CA_1A-1A Bandwidth Combination Set 0 in Table 5.6A.1-3						140	0
		3	See CA_3C Bandwidth combination set 0 in Table 5.6A.1-1							
		7	See CA_7C Bandwidth combination set 2 in Table 5.6A.1-1							
		28		Yes	Yes	Yes	Yes			
CA_1A-1A-3A-3A-7A-28A	-	1	See CA_1A-1A Bandwidth Combination Set 0 in Table 5.6A.1-3						120	0
		3	See CA_3A-3A Bandwidth Combination Set 0 in Table 5.6A.1-3							
		7			Yes	Yes	Yes	Yes		
		28		Yes	Yes	Yes	Yes			
CA_1A-1A-3A-3A-7C-28A	CA_7C	1	See CA_1A-1A Bandwidth Combination Set 0 in Table 5.6A.1-3						140	0
		3	See CA_3A-3A Bandwidth Combination Set 0 in Table 5.6A.1-3							
		7	See CA_7C Bandwidth combination set 2 in Table 5.6A.1-1							
		28		Yes	Yes	Yes	Yes			
CA_1A-3A-3A-7A-28A	-	1	See CA_3A-3A Bandwidth combination set 0 in Table 5.6A.1-3						100	0
		3	See CA_3A-3A Bandwidth combination set 0 in Table 5.6A.1-3							
		7			Yes	Yes	Yes	Yes		
		28		Yes	Yes	Yes	Yes			
CA_1A-3A-3A-7C-28A	CA_7C	1	See CA_3A-3A Bandwidth Combination Set 0 in Table 5.6A.1-3						120	0
		3	See CA_3A-3A Bandwidth Combination Set 0 in Table 5.6A.1-3							
		7	See CA_7C Bandwidth combination set 2 in Table 5.6A.1-1							
		28		Yes	Yes	Yes	Yes			
CA_1A-3A-7A-7A-28A	-	1	See CA_3A-3A Bandwidth combination set 0 in Table 5.6A.1-3						100	0
		3	See CA_3A-3A Bandwidth combination set 0 in Table 5.6A.1-3							
		7	See CA_7A-7A Bandwidth combination set 3 in Table 5.6A.1-3							
		28		Yes	Yes	Yes	Yes			
CA_1A-3A-7A-32A	-	1	See CA_3A-3A Bandwidth combination set 0 in Table 5.6A.1-3						80	0
		3	See CA_3A-3A Bandwidth combination set 0 in Table 5.6A.1-3							
		7			Yes	Yes	Yes	Yes		
		32		Yes	Yes	Yes	Yes			
CA_1A-3A-7A-38A <sup>9</sup>	-	1	See CA_3A-3A Bandwidth combination set 0 in Table 5.6A.1-3						80	0
		3	See CA_3A-3A Bandwidth combination set 0 in Table 5.6A.1-3							
		7		Yes	Yes	Yes	Yes			

		38			Yes	Yes	Yes	Yes			
		1			Yes	Yes	Yes	Yes			
CA_1A-3C-7A-38A <sup>9</sup>	-	3	See CA_3C Bandwidth combination set 0 in Table 5.6A.1-1							100	0
		7			Yes	Yes	Yes	Yes			
		38			Yes	Yes	Yes	Yes			
		1			Yes	Yes	Yes	Yes			
CA_1A-3A-7A-40A	-	3			Yes	Yes	Yes	Yes	80	0	
		7			Yes	Yes	Yes	Yes			
		40			Yes	Yes	Yes	Yes			
		1			Yes	Yes	Yes	Yes			
CA_1A-3A-7A-40C	-	3			Yes	Yes	Yes	Yes	100	0	
		7			Yes	Yes	Yes	Yes			
		40	See CA_40C Bandwidth combination set 1 in Table 5.6A.1-1								
		1			Yes	Yes	Yes	Yes			
CA_1A-3A-7A-42A	-	3			Yes	Yes	Yes	Yes	80	0	
		7			Yes	Yes	Yes	Yes			
		42			Yes	Yes	Yes	Yes			
		1			Yes	Yes	Yes	Yes			
CA_1A-3A-7A-46A	-	3			Yes	Yes	Yes	Yes	80	0	
		7			Yes	Yes	Yes	Yes			
		46			Yes	Yes	Yes	Yes			
		1			Yes	Yes	Yes	Yes			
CA_1A-3A-7A-46C	-	3			Yes	Yes	Yes	Yes	100	0	
		7			Yes	Yes	Yes	Yes			
		46	See CA_46C Bandwidth Combination Set 0 in Table 5.6A.1-1								
		1			Yes	Yes	Yes	Yes			
CA_1A-3A-7A-46D	-	3			Yes	Yes	Yes	Yes	120	0	
		7			Yes	Yes	Yes	Yes			
		46	See CA_46D Bandwidth Combination Set 0 in Table 5.6A.1-1								
		1			Yes	Yes	Yes	Yes			
CA_1A-3A-7A-46E	-	3			Yes	Yes	Yes	Yes	140	0	
		7			Yes	Yes	Yes	Yes			
		46	See CA_46E Bandwidth Combination Set 0 in Table 5.6A.1-1								
		1			Yes	Yes	Yes	Yes			
CA_1A-3A-8A-40A	CA_1A-3A, CA_1A-8A, CA_3A-8A	3			Yes	Yes	Yes	Yes	70	0	
		8	Yes		Yes	Yes					
		40			Yes	Yes	Yes	Yes			
		1			Yes	Yes	Yes	Yes			
CA_1A-3A-8A-11A	-	3			Yes	Yes	Yes	Yes	60	0	
		8			Yes	Yes					
		11			Yes	Yes					
		1			Yes	Yes	Yes	Yes			
CA_1A-3A-8A-20A	-	3			Yes	Yes	Yes	Yes	70	0	
		8			Yes	Yes					
		20			Yes	Yes	Yes	Yes			
		1			Yes	Yes	Yes	Yes			

CA_1A-3A-8A-28A	-	1			Yes	Yes	Yes	Yes	70	0
		3			Yes	Yes	Yes	Yes		
		8			Yes	Yes				
		28			Yes	Yes	Yes	Yes		
CA_1A-3A-8A-38A	CA_1A-3A CA_1A-8A CA_3A-8A	1			Yes	Yes	Yes	Yes	70	0
		3			Yes	Yes	Yes	Yes		
		8			Yes	Yes				
		38			Yes	Yes	Yes	Yes		
CA_1A-3A-8A-42A	-	1			Yes	Yes	Yes	Yes	70	0
		3			Yes	Yes	Yes	Yes		
		8			Yes	Yes				
		42			Yes	Yes	Yes	Yes		
CA_1A-3A-8A-42C	-	1			Yes	Yes	Yes	Yes	90	0
		3			Yes	Yes	Yes	Yes		
		8			Yes	Yes				
		42			See CA_42C Bandwidth Combination Set 0 in Table 5.6A.1-1					
CA_1A-3A-11A-28A	-	1			Yes	Yes	Yes	Yes	70	0
		3			Yes	Yes	Yes	Yes		
		11			Yes	Yes				
		28			Yes	Yes	Yes	Yes		
CA_1A-3A-18A-42A	-	1			Yes	Yes	Yes	Yes	75	0
		3			Yes	Yes	Yes	Yes		
		18			Yes	Yes	Yes			
		42			Yes	Yes	Yes	Yes		
CA_1A-3A-18A-42C	-	1			Yes	Yes	Yes	Yes	95	0
		3			Yes	Yes	Yes	Yes		
		18			Yes	Yes	Yes			
		42			See CA_42C Bandwidth Combination Set 0 in Table 5.6A.1-1					
CA_1A-3A-19A-21A	CA_1A-3A, CA_1A-19A <sup>6</sup> , CA_1A-21A, CA_3A-19A, CA_3A-21A, CA_19A-21A	1			Yes	Yes	Yes	Yes	70	0
		3			Yes	Yes	Yes	Yes		
		19			Yes	Yes	Yes			
		21			Yes	Yes	Yes			
CA_1A-3A-19A-42A	CA_1A-3A, CA_1A-19A <sup>6</sup> , CA_1A-42A, CA_3A-19A, CA_3A-42A, CA_19A-42A <sup>6</sup>	1			Yes	Yes	Yes	Yes	75	0
		3			Yes	Yes	Yes	Yes		
		19			Yes	Yes	Yes			
		42			Yes	Yes	Yes	Yes		
CA_1A-3A-3A-19A-21A	CA_1A-3A CA_1A-19A <sup>6</sup> CA_1A-21A, CA_3A-19A CA_3A-21A CA_19A-21A	1			Yes	Yes	Yes	Yes	90	0
		3			See CA_3A-3A Bandwidth Combination Set 0 in Table 5.6A.1-3					
		19			Yes	Yes	Yes			
		21			Yes	Yes	Yes			
CA_1A-3A-19A-42C	CA_1A-3A, CA_1A-19A <sup>6</sup> , CA_1A-42A, CA_3A-19A, CA_3A-42A, CA_19A-42A <sup>6</sup>	1			Yes	Yes	Yes	Yes	95	0
		3			Yes	Yes	Yes	Yes		
		19			Yes	Yes	Yes			
		42			See CA_42C Bandwidth combination set 0 in Table 5.6A.1-1					
CA_1A-3A-20A-28A <sup>7</sup>	-	1			Yes	Yes	Yes	Yes	80	0
		3			Yes	Yes	Yes	Yes		
		20				Yes	Yes	Yes		
		28			Yes	Yes	Yes	Yes		
CA_1A-3A-3A-20A-28A <sup>7</sup>	-	1			Yes	Yes	Yes	Yes	100	0
		3			See CA_3A-3A Bandwidth combination set 0 in Table 5.6A.1-3					
		20			Yes	Yes	Yes	Yes		
		28			Yes	Yes	Yes	Yes		
CA_1A-3A-20A-32A	-	1			Yes	Yes	Yes	Yes	70	0
		3			Yes	Yes	Yes	Yes		
		20			Yes					



		32			Yes	Yes	Yes	Yes		
		1			Yes	Yes	Yes			
		3			Yes	Yes	Yes			
		20			Yes					
		32			Yes	Yes	Yes	Yes		
CA_1A-3A-20A-42A	-	1			Yes	Yes	Yes	Yes		
		3			Yes	Yes	Yes	Yes		
		20			Yes	Yes	Yes	Yes		
		42			Yes	Yes	Yes	Yes		
CA_1A-3A-20A-43A	-	1			Yes	Yes	Yes			
		3			Yes	Yes	Yes			
		20			Yes					
		43			Yes	Yes	Yes	Yes		
CA_1A-3A-21A-28A	CA_1A-3A, CA_1A-21A, CA_1A-28A, CA_3A-21A, CA_3A-28A <sup>6</sup> , CA_21A-28A	1			Yes	Yes	Yes	Yes		
		3			Yes	Yes	Yes	Yes		
		21			Yes	Yes	Yes			
		28			Yes	Yes				
CA_1A-3A-21A-42A	CA_1A-3A, CA_1A-21A, CA_1A-42A, CA_3A-21A, CA_3A-42A, CA_21A-42A	1			Yes	Yes	Yes	Yes		
		3			Yes	Yes	Yes	Yes		
		21			Yes	Yes	Yes			
		42			Yes	Yes	Yes	Yes		
CA_1A-3A-21A-42C	CA_1A-3A, CA_1A-21A, CA_1A-42A, CA_3A-21A, CA_3A-42A, CA_21A-42A	1			Yes	Yes	Yes	Yes		
		3			Yes	Yes	Yes	Yes		
		21			Yes	Yes	Yes			
		42			See CA_42C Bandwidth combination set 0 in Table 5.6A.1-1					
CA_1A-3A-28A-40A	-	1			Yes	Yes	Yes	Yes		
		3			Yes	Yes	Yes	Yes		
		28			Yes	Yes	Yes	Yes		
		40			Yes	Yes	Yes	Yes		
CA_1A-3A-28A-40C	-	1			Yes	Yes	Yes	Yes		
		3			Yes	Yes	Yes	Yes		
		28			Yes	Yes	Yes	Yes		
		40			See CA_40C Bandwidth combination set 0 in Table 5.6A.1-1					
CA_1A-3A-28A-42A	CA_1A-3A, CA_1A-28A, CA_1A-42A, CA_3A-28A <sup>6</sup> , CA_3A-42A, CA_28A-42A	1			Yes	Yes	Yes	Yes		
		3			Yes	Yes	Yes	Yes		
		28			Yes	Yes				
		42			Yes	Yes	Yes	Yes		
CA_1A-3A-28A-42C	CA_1A-3A, CA_1A-28A, CA_1A-42A, CA_3A-28A <sup>6</sup> , CA_3A-42A, CA_28A-42A	1			Yes	Yes	Yes	Yes		
		3			Yes	Yes	Yes	Yes		
		28			Yes	Yes				
		42			See CA_42C Bandwidth combination set 0 in Table 5.6A.1-1					
CA_1A-3A-32A-42A	-	1			Yes	Yes	Yes			
		3			Yes	Yes	Yes			
		32			Yes	Yes	Yes	Yes		
		42			Yes	Yes	Yes	Yes		
CA_1A-3A-32A-43A	-	1			Yes	Yes	Yes			
		3			Yes	Yes	Yes			
		32			Yes	Yes	Yes	Yes		
		43			Yes	Yes	Yes	Yes		
CA_1A-3A-41A-42A	CA_1A-3A CA_1A-42A CA_3A-42A	1			Yes	Yes	Yes	Yes		
		3			Yes	Yes	Yes	Yes		
		41			Yes	Yes	Yes	Yes		
		42			Yes	Yes	Yes	Yes		
CA_1A-3A-41C-42A		1			Yes	Yes	Yes	Yes		
		3			Yes	Yes	Yes	Yes		

	CA_1A-3A CA_1A-42A CA_3A-42A	41	See CA_41C Bandwidth Combination Set 0 in Table 5.6A.1-1						
		42		Yes	Yes	Yes			Yes
CA_1A-3A-41A- 42C	CA_1A-3A	1		Yes	Yes	Yes	Yes	100	0
	CA_1A-42A	3		Yes	Yes	Yes	Yes		
	CA_1A-42C	41		Yes	Yes	Yes	Yes		
	CA_3A-42A CA_3A-42C CA_42C	42	See CA_42C Bandwidth Combination Set 0 in Table 5.6A.1-1						
CA_1A-3A-41C- 42C	CA_1A-3A, CA_1A-42A, CA_1A-42C, CA_3A-42A, CA_3A-42C CA_42C	1		Yes	Yes	Yes	Yes	120	0
		3		Yes	Yes	Yes	Yes		
		41	See CA_41C Bandwidth Combination Set 0 in Table 5.6A.1-1						
		42	See CA_42C Bandwidth Combination Set 0 in Table 5.6A.1-1						
CA_1A-3A-42A- 43A	-	1		Yes	Yes	Yes		70	0
		3		Yes	Yes	Yes			
		42		Yes	Yes	Yes	Yes		
		43		Yes	Yes	Yes	Yes		
CA_1A-5A-7A- 28A	-	1		Yes	Yes	Yes		65	0
		5		Yes	Yes				
		7		Yes	Yes	Yes	Yes		
		28		Yes	Yes	Yes	Yes		
CA_1A-20A-32A- 42A	-	1		Yes	Yes	Yes		60	0
		20		Yes					
		32		Yes	Yes	Yes	Yes		
		42		Yes	Yes	Yes	Yes		
CA_1A-20A-32A- 43A	-	1		Yes	Yes	Yes		60	0
		20		Yes					
		32		Yes	Yes	Yes	Yes		
		43		Yes	Yes	Yes	Yes		

CA_1A-7A-8A-20A	-	1			Yes	Yes	Yes	Yes	70	0
		7				Yes	Yes	Yes		
		8			Yes	Yes				
		20			Yes	Yes	Yes	Yes		
CA_1A-7A-8A-40A	-	1			Yes	Yes	Yes	Yes	70	0
		7				Yes	Yes	Yes		
		8			Yes	Yes				
		40			Yes	Yes	Yes	Yes		
CA_1A-5A-7A-46A	CA_1A-5A <sup>6</sup> , CA_1A-7A, CA_5A-7A	1			Yes	Yes	Yes	Yes	70	0
		5			Yes	Yes				
		7				Yes	Yes	Yes		
		46						Yes		
CA_1A-5A-7A-46C	-	1			Yes	Yes	Yes	Yes	90	0
		5			Yes	Yes				
		7				Yes	Yes	Yes		
		46			See CA_46C Bandwidth combination set 0 in Table 5.6A.1-1					
CA_1A-7A-8A-40C	-	1			Yes	Yes	Yes	Yes	90	0
		7				Yes	Yes	Yes		
		8			Yes	Yes				
		40			See CA_40C Bandwidth combination set 1 in Table 5.6A.1-1					
CA_1A-7A-20A-28A <sup>7</sup>	-	1			Yes	Yes	Yes	Yes	80	0
		7				Yes	Yes	Yes		
		20				Yes	Yes	Yes		
		28			Yes	Yes	Yes	Yes		
CA_1A-7A-20A-32A	-	1			Yes	Yes	Yes	Yes	70	0
		7				Yes	Yes	Yes		
		20			Yes	Yes				
		32			Yes	Yes	Yes	Yes		
CA_1A-7A-20A-42A	-	1			Yes	Yes	Yes	Yes	80	0
		7				Yes	Yes	Yes		
		20			Yes	Yes	Yes	Yes		
		42			Yes	Yes	Yes	Yes		
CA_1A-7A-28A-40A	-	1			Yes	Yes	Yes	Yes	80	0
		7				Yes	Yes	Yes		
		28			Yes	Yes	Yes	Yes		
		40			Yes	Yes	Yes	Yes		
CA_1A-7A-28A-40C	-	1			Yes	Yes	Yes	Yes	100	0
		7				Yes	Yes	Yes		
		28			Yes	Yes	Yes	Yes		
		40			See CA_40C Bandwidth combination set 0 in Table 5.6A.1-1					
CA_1A-8A-11A-28A	-	1			Yes	Yes	Yes	Yes	60	0
		8			Yes	Yes				
		11			Yes	Yes				
		28			Yes	Yes	Yes	Yes		
CA_1A-8A-11A-42A	-	1			Yes	Yes	Yes	Yes	60	0
		8			Yes	Yes				
		11			Yes	Yes				
		42			Yes	Yes	Yes	Yes		
CA_1A-8A-11A-42C	-	1			Yes	Yes	Yes	Yes	80	0
		8			Yes	Yes				
		11			Yes	Yes				
		42			See CA_42C Bandwidth Combination Set 0 in Table 5.6A.1-1					
CA_1A-8A-20A-28A	-	1			Yes	Yes	Yes	Yes	70	0
		8			Yes	Yes				
		20				Yes	Yes	Yes		
		28			Yes	Yes	Yes	Yes		
CA_1A-19A-21A-42A	CA_1A-19A <sup>6</sup> , CA_1A-21A, CA_1A-42A, CA_19A-21A, CA_19A-42A <sup>6</sup> , CA_21A-42A	1			Yes	Yes	Yes	Yes	70	0
		19			Yes	Yes	Yes			
		21			Yes	Yes	Yes			
		42			Yes	Yes	Yes	Yes		

CA_1A-19A-21A-42C	CA_1A-19A <sup>6</sup> , CA_1A-21A, CA_1A-42A, CA_19A-21A, CA_19A-42A <sup>6</sup> , CA_21A-42A	1			Yes	Yes	Yes	Yes	90	0
		19			Yes	Yes	Yes			
		21			Yes	Yes	Yes			
		42	See CA_42C Bandwidth combination set 0 in Table 5.6A.1-1							
CA_1A-21A-28A-42A	CA_1A-21A, CA_1A-28A, CA_1A-42A, CA_21A-28A, CA_21A-42A, CA_28A-42A	1			Yes	Yes	Yes	Yes	65	0
		21			Yes	Yes	Yes			
		28			Yes	Yes				
		42			Yes	Yes	Yes	Yes		
CA_1A-21A-28A-42C	CA_1A-21A, CA_1A-28A, CA_1A-42A, CA_21A-28A, CA_21A-42A, CA_28A-42A	1			Yes	Yes	Yes	Yes	85	0
		21			Yes	Yes	Yes			
		28			Yes	Yes				
		42	See CA_42C Bandwidth combination set 0 in Table 5.6A.1-1							
CA_1A-32A-42A-43A	-	1			Yes	Yes	Yes		75	0
		32			Yes	Yes	Yes	Yes		
		42			Yes	Yes	Yes	Yes		
		43			Yes	Yes	Yes	Yes		

CA_2A-2A-5A-12A-66A	-	2	See CA_2A-2A Bandwidth Combination Set 0 in Table 5.6A.1-3				80	0		
		5		Yes	Yes					
		12		Yes	Yes					
		66		Yes	Yes	Yes			Yes	
CA_2A-2A-5A-30A-66A	-	2	See CA_2A-2A Bandwidth Combination Set 0 in Table 5.6A.1-3				80	0		
		5		Yes	Yes					
		30		Yes	Yes					
		66		Yes	Yes	Yes			Yes	
CA_2A-2A-7A-12A-66A	-	2	See CA_2A-2A Bandwidth Combination Set 0 in Table 5.6A.1-3				90	0		
		7		Yes	Yes	Yes			Yes	
		12		Yes	Yes					
		66		Yes	Yes	Yes			Yes	
CA_2A-2A-12A-30A-66A	-	2	See CA_2A-2A Bandwidth Combination Set 0 in Table 5.6A.1-3				80	0		
		12		Yes	Yes					
		30		Yes	Yes					
		66		Yes	Yes	Yes			Yes	
CA_2A-2A-14A-30A-66A	CA_2A-14A CA_14A-30A CA_14A-66A	2	See CA_2A-2A Bandwidth Combination Set 0 in Table 5.6A.1-3				80	0		
		14		Yes	Yes					
		30		Yes	Yes					
		66		Yes	Yes	Yes			Yes	
CA_2A-4A-5A-12A	-	2		Yes	Yes	Yes	Yes	60	0	
		4		Yes	Yes	Yes	Yes			
		5		Yes	Yes					
		12		Yes	Yes					
CA_2A-4A-5A-29A	CA_2A-4A	2		Yes	Yes	Yes	Yes	60	0	
		4		Yes	Yes	Yes	Yes			
		5		Yes	Yes					
		29		Yes	Yes					
CA_2A-4A-5A-30A	-	2		Yes	Yes	Yes	Yes	60	0	
		4		Yes	Yes	Yes	Yes			
		5		Yes	Yes					
		30		Yes	Yes					
CA_2A-4A-5B-30A	-	2		Yes	Yes	Yes	Yes	70	0	
		4		Yes	Yes	Yes	Yes			
		5	See CA_5B Bandwidth combination set 0 in Table 5.6A.1-1							
		30		Yes	Yes					
CA_2A-4A-7A-12A	-	2		Yes	Yes	Yes	Yes	70	0	
		4		Yes	Yes	Yes	Yes			
		7		Yes	Yes	Yes	Yes			
		12		Yes	Yes					
CA_2A-4A-12A-30A	-	2		Yes	Yes	Yes	Yes	60	0	
		4		Yes	Yes	Yes	Yes			
		12		Yes	Yes					
		30		Yes	Yes					
CA_2A-4A-29A-30A	-	2		Yes	Yes	Yes	Yes	60	0	
		4		Yes	Yes	Yes	Yes			
		29		Yes	Yes					
		30		Yes	Yes					
CA_2A-5A-7A-28A	-	2		Yes	Yes	Yes	Yes	70	0	
		5		Yes	Yes					
		7		Yes	Yes	Yes	Yes			
		28		Yes	Yes	Yes	Yes			

CA_2A-5A-12A-66A	-	2			Yes	Yes	Yes	Yes	60	0
		5			Yes	Yes				
		12			Yes	Yes				
		66			Yes	Yes	Yes	Yes		
CA_2A-5A-30A-66A	-	2			Yes	Yes	Yes	Yes	60	0
		5			Yes	Yes				
		30			Yes	Yes				
		66			Yes	Yes	Yes	Yes		
CA_2A-5A-30A-66A-66A	-	2			Yes	Yes	Yes	Yes	80	0
		5			Yes	Yes				
		30			Yes	Yes				
		66	See CA_66A-66A Bandwidth Combination Set 0 in Table 5.6A.1-3							
CA_2A-5B-30A-66A	-	2			Yes	Yes	Yes	Yes	70	0
		5	See CA_5B Bandwidth Combination Set 0 in Table 5.6A.1-1							
		30			Yes	Yes				
		66			Yes	Yes	Yes	Yes		
CA_2A-5A-46A-66A	-	2			Yes	Yes	Yes	Yes	70	0
		5			Yes	Yes				
		46						Yes		
		66			Yes	Yes	Yes	Yes		
CA_2A-5A-46C-66A	-	2			Yes	Yes	Yes	Yes	90	0
		5			Yes	Yes				
		46	See CA_46C Bandwidth combination set 0 in Table 5.6A.1-1							
		66			Yes	Yes	Yes	Yes		
CA_2A-5A-46D-66A	-	2			Yes	Yes	Yes	Yes	110	0
		5			Yes	Yes				
		46	See CA_46D Bandwidth combination set 0 in Table 5.6A.1-1							
		66			Yes	Yes	Yes	Yes		
CA_2A-5A-46E-66A	-	2			Yes	Yes	Yes	Yes	130	0
		5			Yes	Yes				
		46	See CA_46E Bandwidth combination set 0 in Table 5.6A.1-1							
		66			Yes	Yes	Yes	Yes		
CA_2A-5A-46A-66A-66A	-	2			Yes	Yes	Yes	Yes	90	0
		5			Yes	Yes				
		46						Yes		
		66	See CA_66A-66A Bandwidth combination set 0 in Table 5.6A.1-3							
CA_2A-5A-46C-66A-66A	-	2			Yes	Yes	Yes	Yes	110	0
		5			Yes	Yes				
		46	See CA_46C Bandwidth combination set 0 in Table 5.6A.1-1							
		66	See CA_66A-66A Bandwidth combination set 0 in Table 5.6A.1-3							
CA_2A-5A-46D-66A-66A	-	2			Yes	Yes	Yes	Yes	130	0
		5			Yes	Yes				
		46	See CA_46D Bandwidth combination set 0 in Table 5.6A.1-1							
		66	See CA_66A-66A Bandwidth combination set 0 in Table 5.6A.1-3							
CA_2A-5A-48A-66A	CA_2A-66A CA_2A-48A CA_48A-66A CA_5A-66A CA_5A-48A CA_2A-5A	2	Yes	Yes	Yes	Yes	Yes	Yes	70	0
		5			Yes	Yes				
		48			Yes	Yes	Yes	Yes		
		66	Yes	Yes	Yes	Yes	Yes	Yes		
CA_2A-5A-48A-66A-66A	CA_2A-66A CA_2A-48A CA_48A-66A CA_5A-66A CA_5A-48A CA_2A-5A	2	Yes	Yes	Yes	Yes	Yes	Yes	90	0
		5			Yes	Yes				
		48			Yes	Yes	Yes	Yes		
		66	See CA_66A-66A Bandwidth Combination Set 0 in Table 5.6A.1-3							

CA_2A-5A-48C-66A	CA_2A-66A CA_2A-48A CA_48A-66A CA_5A-66A CA_5A-48A CA_2A-5A	2	Yes	Yes	Yes	Yes	Yes	Yes	90	0
		5			Yes	Yes				
		48	See CA_48C Bandwidth combination set 0 in Table 5.6A1-1							
		66	Yes	Yes	Yes	Yes	Yes	Yes		
CA_2A-5A-48C-66A-66A	CA_2A-66A CA_2A-48A CA_48A-66A CA_5A-66A CA_5A-48A	2	Yes	Yes	Yes	Yes	Yes	Yes	110	0
		5			Yes	Yes				
		48	See CA_48C Bandwidth combination set 0 in Table 5.6A1-1							
		66	See CA_66A-66A Bandwidth Combination Set 0 in Table 5.6A.1-3							
CA_2A-5A-48D-66A	CA_2A-66A CA_2A-48A CA_48A-66A CA_5A-66A CA_5A-48A CA_2A-5A	2	Yes	Yes	Yes	Yes	Yes	Yes	110	0
		5			Yes	Yes				
		48	See CA_48D Bandwidth combination set 0 in Table 5.6A1-1							
		66	Yes	Yes	Yes	Yes	Yes	Yes		
CA_2A-5A-48D-66A-66A	CA_2A-66A CA_2A-48A CA_48A-66A CA_5A-66A CA_5A-48A CA_2A-5A	2	Yes	Yes	Yes	Yes	Yes	Yes	130	0
		5	Yes		Yes	Yes				
		48	See CA_48D Bandwidth combination set 0 in Table 5.6A1-1							
		66	See CA_66A-66A Bandwidth Combination Set 0 in Table 5.6A.1-3							
CA_2A-7A-12A-66A	-	2			Yes	Yes	Yes	Yes	70	0
		7			Yes	Yes	Yes	Yes		
		12			Yes	Yes				
		66			Yes	Yes	Yes	Yes		
CA_2A-7A-12B-66A	-	2			Yes	Yes	Yes	Yes	75	0
		7			Yes	Yes	Yes	Yes		
		12	See CA_12B Bandwidth combination set 0 in Table 5.6A.1-1							
		66			Yes	Yes	Yes	Yes		
CA_2A-7A-13A-66A	-	2			Yes	Yes	Yes	Yes	70	0
		7			Yes	Yes	Yes	Yes		
		13			Yes	Yes				
		66			Yes	Yes	Yes	Yes		
CA_2A-7C-13A-66A	-	2			Yes	Yes	Yes	Yes	90	0
		7	See CA_7C Bandwidth combination set 1 in Table 5.6A.1-1							
		13			Yes	Yes				
		66			Yes	Yes	Yes	Yes		
CA_2A-7A-26A-66A	-	2		Yes	Yes	Yes	Yes	Yes	75	0
		7			Yes	Yes	Yes	Yes		
		26		Yes	Yes	Yes	Yes			
		66		Yes	Yes	Yes	Yes	Yes		
CA_2A-7A-29A-66A	-	2			Yes	Yes	Yes	Yes	70	0
		7			Yes	Yes	Yes	Yes		
		29			Yes	Yes				
		66			Yes	Yes	Yes	Yes		
CA_2A-7C-29A-66A	-	2			Yes	Yes	Yes	Yes	90	0
		7	See CA_7C Bandwidth combination set 1 in Table 5.6A.1-1							
		29			Yes	Yes				
		66			Yes	Yes	Yes	Yes		
CA_2A-7A-7A-29A-66A	-	2			Yes	Yes	Yes	Yes	90	0
		7	See CA_7A-7A Bandwidth combination set 3 in Table 5.6A.1-3							
		29			Yes	Yes				
		66			Yes	Yes	Yes	Yes		
CA_2A-7A-46A-66A	-	2			Yes	Yes	Yes	Yes	80	0
		7			Yes	Yes	Yes	Yes		
		46			Yes	Yes	Yes	Yes		
		66			Yes	Yes	Yes	Yes		

CA_2A-12A-30A-66A	-	2		Yes	Yes	Yes	Yes	60	0
		12		Yes	Yes				
		30		Yes	Yes				
		66		Yes	Yes	Yes	Yes		
CA_2A-12A-30A-66A-66A	-	2		Yes	Yes	Yes	Yes	80	0
		12		Yes	Yes				
		30		Yes	Yes				
		66	See CA_66A-66A Bandwidth Combination Set 0 in Table 5.6A.1-3						
CA_2A-13A-46A-66A	CA_2A-13A	2		Yes	Yes	Yes	Yes	70	0
		13		Yes	Yes				
		46					Yes		
		66		Yes	Yes	Yes	Yes		
CA_2A-13A-46C-66A	CA_2A-13A	2		Yes	Yes	Yes	Yes	90	0
		13		Yes	Yes				
		46	See CA_46C Bandwidth combination set 0 in Table 5.6A.1-1						
		66		Yes	Yes	Yes	Yes		
CA_2A-13A-46D-66A	CA_2A-13A	2		Yes	Yes	Yes	Yes	110	0
		13		Yes	Yes				
		46	See CA_46D Bandwidth combination set 0 in Table 5.6A.1-1						
		66		Yes	Yes	Yes	Yes		
CA_2A-5A-46E-66A	-	2		Yes	Yes	Yes	Yes	130	0
		5		Yes	Yes				
		46	See CA_46E Bandwidth combination set 0 in Table 5.6A.1-1						
		66		Yes	Yes	Yes	Yes		
CA_2A-13A-46A-66A-66A	-	2		Yes	Yes	Yes	Yes	90	0
		13		Yes	Yes				
		46					Yes		
		66	See CA_66A-66A Bandwidth combination set 0 in Table 5.6A.1-3						
CA_2A-13A-46C-66A-66A	-	2		Yes	Yes	Yes	Yes	110	0
		13		Yes	Yes				
		46	See CA_46C Bandwidth combination set 0 in Table 5.6A.1-1						
		66	See CA_66A-66A Bandwidth combination set 0 in Table 5.6A.1-3						
CA_2A-13A-46D-66A-66A	-	2		Yes	Yes	Yes	Yes	130	0
		13		Yes	Yes				
		46	See CA_46D Bandwidth combination set 0 in Table 5.6A.1-1						
		66	See CA_66A-66A Bandwidth combination set 0 in Table 5.6A.1-3						



CA_2A-13A-48A-66A	CA_2A-13A CA_2A-66A CA_2A-48A CA_48A-66A CA_13A-66A CA_13A-48A	2			Yes	Yes	Yes	Yes	70	0	
		13			Yes	Yes					
		48			Yes	Yes	Yes	Yes			
		66			Yes	Yes	Yes	Yes			
CA_2A-13A-48A-66A-66A	CA_2A-66A CA_2A-48A CA_48A-66A CA_13A-66A CA_13A-48A	2			Yes	Yes	Yes	Yes	90	0	
		13			Yes	Yes					
		48			Yes	Yes	Yes	Yes			
		66	See CA_66A-66A Bandwidth Combination Set 0 in Table 5.6A.1-3								
CA_2A-13A-48C-66A	CA_2A-13A CA_2A-48A CA_2A-66A CA_13A-66A CA_13A-48A CA_48A-66A	2			Yes	Yes	Yes	Yes	90	0	
		13			Yes	Yes					
		48	See CA_48C Bandwidth combination set 0 in the Table 5.6A.1-1								
		66			Yes	Yes	Yes	Yes			
CA_2A-13A-48C-66A-66A	CA_2A-66A CA_2A-48A CA_48A-66A CA_13A-66A CA_13A-48A	2			Yes	Yes	Yes	Yes	110	0	
		13			Yes	Yes					
		48	See CA_48C Bandwidth combination set 0 in the Table 5.6A.1-1								
		66	See CA_66A-66A Bandwidth Combination Set 0 in Table 5.6A.1-3								
CA_2A-13A-48D-66A	CA_2A-66A CA_2A-48A CA_48A-66A CA_13A-66A CA_13A-48A	2			Yes	Yes	Yes	Yes	110	0	
		13			Yes	Yes					
		48	See CA_48D Bandwidth combination set 0 in the Table 5.6A.1-1								
		66			Yes	Yes	Yes	Yes			
CA_2A-13A-48D-66A-66A	CA_2A-66A CA_2A-48A CA_48A-66A CA_13A-66A CA_13A-48A	2			Yes	Yes	Yes	Yes	130	0	
		13			Yes	Yes					
		48	See CA_48D Bandwidth combination set 0 in the Table 5.6A.1-1								
		66	See CA_66A-66A Bandwidth Combination Set 0 in Table 5.6A.1-3								
CA_2A-13A-46E-66A	CA_2A-13A	2	Yes	Yes	Yes	Yes	Yes	Yes	130	0	
		13			Yes	Yes					
		46	See the CA_46E Bandwidth combination set 0 in the Table 5.6A.1-1								
		66			Yes	Yes	Yes	Yes			
CA_2A-13A-48A-48A-66A	CA_2A-13A CA_13A-66A	2			Yes	Yes	Yes	Yes	90	0	
		13			Yes	Yes					
		48	See CA_48A-48A Bandwidth combination set 0 in the Table 5.6A.1-3								
		66			Yes	Yes	Yes	Yes			
CA_2A-14A-30A-66A	CA_2A-14A CA_14A-30A CA_14A-66A	2			Yes	Yes	Yes	Yes	60	0	
		14			Yes	Yes					
		30			Yes	Yes					
		66			Yes	Yes	Yes	Yes			
CA_2A-14A-30A-66A-66A	CA_2A-14A CA_14A-30A CA_14A-66A	2			Yes	Yes	Yes	Yes	80	0	
		14			Yes	Yes					
		30			Yes	Yes					
		66	See CA_66A-66A Bandwidth Combination Set 0 in Table 5.6A.1-3								
CA_2A-29A-30A-66A	-	2			Yes	Yes	Yes	Yes	60	0	
		29			Yes	Yes					
		30			Yes	Yes					
		66			Yes	Yes	Yes	Yes			
CA_2A-46A-48A-66A	CA_2A-48A CA_48A-66A	2			Yes	Yes	Yes	Yes	80	0	
		46						Yes			
		48			Yes	Yes	Yes	Yes			
		66			Yes	Yes	Yes	Yes			

CA_2A-46A-48C-66A	CA_2A-48A CA_48A-66A	2			Yes	Yes	Yes	Yes	100	0	
		46									Yes
		48	See the CA_48C Bandwidth combination set 0 in Table 5.6A.1-1								
CA_2A-46A-48D-66A	-	66			Yes	Yes	Yes	Yes	120	0	
		2			Yes	Yes	Yes	Yes			
		46									Yes
CA_2A-46C-48A-66A	CA_2A-48A CA_48A-66A	48	See the CA_48C Bandwidth combination set 0 in Table 5.6A.1-1						100	0	
		66			Yes	Yes	Yes	Yes			
		2			Yes	Yes	Yes	Yes			
CA_2A-46C-48C-66A	CA_2A-48A CA_48A-66A	46	See the CA_46C Bandwidth combination set 0 in Table 5.6A.1-1						120	0	
		48	See the CA_48C Bandwidth combination set 0 in Table 5.6A.1-1								
		66			Yes	Yes	Yes	Yes			
CA_2A-46C-48D-66A	-	2			Yes	Yes	Yes	Yes	140	0	
		46	See the CA_46C Bandwidth combination set 0 in Table 5.6A.1-1								
		48	See the CA_48D Bandwidth combination set 0 in Table 5.6A.1-1								
CA_2A-46D-48A-66A	CA_2A-48A CA_48A-66A	66			Yes	Yes	Yes	Yes	120	0	
		2			Yes	Yes	Yes	Yes			
		46	See the CA_46D Bandwidth combination set 0 in Table 5.6A.1-1								
CA_2A-46D-48C-66A	CA_2A-48A CA_48A-66A	48			Yes	Yes	Yes	Yes	140	0	
		66			Yes	Yes	Yes	Yes			
		2			Yes	Yes	Yes	Yes			
CA_2A-46E-48A-66A	CA_2A-48A CA_48A-66A	46	See CA_46E Bandwidth combination set 0 in Table 5.6A.1-1						140	0	
		48			Yes	Yes	Yes	Yes			
		66			Yes	Yes	Yes	Yes			
CA_3A-5A-7A-28A	-	3			Yes	Yes	Yes	Yes	70	0	
		5			Yes	Yes					
		7			Yes	Yes	Yes	Yes			
CA_3A-5A-7C-28A	-	28			Yes	Yes	Yes	Yes	90	0	
		3			Yes	Yes	Yes	Yes			
		5			Yes	Yes					
CA_3A-3A-5A-7A-28A	-	7	See CA_7C Bandwidth Combination Set 1 in Table 5.6A.1-1						90	0	
		28			Yes	Yes	Yes	Yes			
		3	See CA_3A-3A Bandwidth Combination Set 0 in Table 5.6A.1-3								
CA_3A-7A-8A-20A	-	5			Yes	Yes			70	0	
		7				Yes	Yes	Yes			
		28			Yes	Yes	Yes	Yes			
CA_3A-7A-8A-38A <sup>9</sup>	-	3			Yes	Yes	Yes	Yes	70	0	
		7				Yes	Yes	Yes			
		8			Yes	Yes					
		38			Yes	Yes	Yes	Yes			

CA_3C-7A-8A-38A <sup>1</sup>	-	3	See CA_3C Bandwidth combination set 0 in Table 5.6A.1-1				90	0		
		7			Yes	Yes			Yes	Yes
		8			Yes	Yes				
		38			Yes	Yes			Yes	Yes
CA_3A-7A-8A-40A	-	3			Yes	Yes	Yes	Yes		
		7				Yes	Yes	Yes		
		8			Yes	Yes				
CA_3A-7A-8A-40C	-	3			Yes	Yes	Yes	Yes		
		7				Yes	Yes	Yes		
		8			Yes	Yes				
CA_3A-7A-8A-40C	-	40	See CA_40C Bandwidth combination set 1 in Table 5.6A.1-1				90	0		
		3			Yes	Yes			Yes	Yes
CA_3A-7A-20A-28A <sup>7</sup>	-	7			Yes	Yes	Yes	Yes		
		20				Yes	Yes	Yes		
		28			Yes	Yes	Yes	Yes		
		3	See CA_3C Bandwidth combination set 0 in Table 5.6A.1-1				100	0		
7			Yes	Yes	Yes	Yes				
20				Yes	Yes	Yes				
28			Yes	Yes	Yes	Yes				
CA_3A-7A-20A-32A	CA_3A-7A, CA_3A-20A, CA_7A-20A	3			Yes	Yes	Yes	Yes		
		7				Yes	Yes	Yes		
		20			Yes	Yes	Yes	Yes		
		32			Yes	Yes	Yes	Yes		
CA_3A-7A-20A-42A	-	3			Yes	Yes	Yes	Yes		
		7				Yes	Yes	Yes		
		20			Yes	Yes	Yes	Yes		
		42			Yes	Yes	Yes	Yes		
CA_3A-7A-28A-38A <sup>9</sup>	-	3			Yes	Yes	Yes	Yes		
		7				Yes	Yes	Yes		
		28			Yes	Yes	Yes	Yes		
		38			Yes	Yes	Yes	Yes		
CA_3C-7A-28A-38A <sup>9</sup>	-	3	See CA_3C Bandwidth combination set 0 in Table 5.6A.1-1				100	0		
		7			Yes	Yes			Yes	Yes
		28			Yes	Yes			Yes	Yes
		38			Yes	Yes			Yes	Yes
CA_3A-7A-28A-40A	-	3			Yes	Yes	Yes	Yes		
		7				Yes	Yes	Yes		
		28			Yes	Yes	Yes	Yes		
		40			Yes	Yes	Yes	Yes		
CA_3A-7A-28A-40C	-	3			Yes	Yes	Yes	Yes		
		7				Yes	Yes	Yes		
		28			Yes	Yes	Yes	Yes		
		40	See CA_40C Bandwidth combination set 0 in Table 5.6A.1-1				100	0		
3			Yes	Yes	Yes	Yes				
7				Yes	Yes	Yes				
32			Yes	Yes	Yes	Yes				
CA_3A-7A-32A-46A	-	3			Yes	Yes	Yes	Yes		
		7				Yes	Yes	Yes		
		32			Yes	Yes	Yes	Yes		
		46					Yes			
CA_3A-7A-32A-46C	-	3			Yes	Yes	Yes	Yes		
		7				Yes	Yes	Yes		
		32			Yes	Yes	Yes	Yes		
		46	See CA_46C Bandwidth Combination Set 0 in Table 5.6A.1-1				100	0		
3			Yes	Yes	Yes	Yes				
7				Yes	Yes	Yes				
32			Yes	Yes	Yes	Yes				
CA_3A-7A-32A-46D	-	3			Yes	Yes	Yes	Yes		
		7				Yes	Yes	Yes		
		32			Yes	Yes	Yes	Yes		
		46	See CA_46D Bandwidth Combination Set 0 in Table 5.6A.1-1				120	0		
3			Yes	Yes	Yes	Yes				
7				Yes	Yes	Yes				
32			Yes	Yes	Yes	Yes				
CA_3A-7A-32A-46E	-	3			Yes	Yes	Yes	Yes		
		7				Yes	Yes	Yes		
		32			Yes	Yes	Yes	Yes		

		46	See CA_46E of Bandwidth Combination Set 0 in Table 5.6A.1-1					
CA_3A-8A-11A-28A	-	3		Yes	Yes	Yes	Yes	
		8		Yes	Yes		Yes	
		11		Yes	Yes			
		28		Yes	Yes	Yes	Yes	
CA_3A-8A-20A-28A	-	3		Yes	Yes	Yes	Yes	
		8		Yes	Yes			
		20			Yes	Yes	Yes	
		28		Yes	Yes	Yes	Yes	
CA_3A-19A-21A-42A	-	3		Yes	Yes	Yes	Yes	
		19		Yes	Yes	Yes		
		21		Yes	Yes	Yes		
		42		Yes	Yes	Yes	Yes	
CA_3A-19A-21A-42C	-	3		Yes	Yes	Yes	Yes	
		19		Yes	Yes	Yes		
		21		Yes	Yes	Yes		
		42	See CA_42C Bandwidth Combination Set 0 in Table 5.6A.1-1					
CA_3A-20A-32A-42A	-	3		Yes	Yes	Yes		
		20		Yes				
		32		Yes	Yes	Yes	Yes	
		42		Yes	Yes	Yes	Yes	
CA_3A-20A-32A-43A	-	3		Yes	Yes	Yes		
		20		Yes				
		32		Yes	Yes	Yes	Yes	
		43		Yes	Yes	Yes	Yes	
CA_3A-21A-28A-42A	-	3		Yes	Yes	Yes	Yes	
		21		Yes	Yes	Yes		
		28		Yes	Yes			
		42		Yes	Yes	Yes	Yes	
CA_3A-21A-28A-42C	-	3		Yes	Yes	Yes	Yes	
		21		Yes	Yes	Yes		
		28		Yes	Yes			
		42	See CA_42C Bandwidth Combination Set 0 in Table 5.6A.1-1					
CA_3A-28A-41A-42A	CA_3A-41A, CA_41A-42A	3		Yes	Yes	Yes	Yes	
		28		Yes	Yes			
		41			Yes	Yes	Yes	
		42			Yes	Yes	Yes	
CA_3A-28A-41A-42C	CA_42C	3		Yes	Yes	Yes	Yes	
		28		Yes	Yes			
		41			Yes	Yes	Yes	
		42	See CA_42C Bandwidth combination set 1 in Table 5.6A.1-1					
CA_3A-28A-41C-42A	-	3		Yes	Yes	Yes	Yes	
		28		Yes	Yes			
		41	See CA_41C Bandwidth Combination Set 0 in Table 5.6A.1-1					
		42			Yes	Yes	Yes	
CA_3A-28A-41C-42C	CA_42C	3		Yes	Yes	Yes	Yes	
		28		Yes	Yes			
		41	See the CA_41C Bandwidth combination set 0 in Table 5.6A.1-1					
		42	See the CA_42C Bandwidth combination set 1 in Table 5.6A.1-1					
CA_3A-32A-42A-43A	-	3		Yes	Yes	Yes		
		32		Yes	Yes	Yes	Yes	
		42		Yes	Yes	Yes	Yes	
		43		Yes	Yes	Yes	Yes	

- NOTE 1: The CA Configuration refers to a combination of an operating band and a CA bandwidth class specified in Table 5.6A-1 (the indexing letter). Absence of a CA bandwidth class for an operating band implies support of all classes.
- NOTE 2: For each band combination, all combinations of indicated bandwidths belong to the set.
- NOTE 3: For the supported CC bandwidth combinations, the CC downlink and uplink bandwidths are equal.
- NOTE 4: A terminal which supports a DL CA configuration shall support all the lower order fallback DL CA combinations and it shall support at least one bandwidth combination set for each of the constituent lower order DL combinations containing all the bandwidths specified within each specific combination set of the upper order DL combination.
- NOTE 5: Uplink CA configurations are the configurations supported by the present release of specifications.
- NOTE 6: If the UE supports any uplink CA configuration for corresponding downlink CA configuration it shall support this uplink CA configuration.
- NOTE 7: Power imbalance between downlink carriers on Band 20 and Band 28 is assumed to be within [6dB].
- NOTE 8: UL carrier is only supported on Band 1, Band 3 or Band 5 not Band 41 because the fall back mode 2DL/1UL CA\_1A-41A has the limitation that UL carrier is only supported on Band 1.
- NOTE 9: UL carrier shall be supported in Band 1, 3, 8 or 28 only. Power imbalance between downlink carriers on Band 7 and Band 38 is assumed to be within [6dB].

**Table 5.6A.1-2c: E-UTRA CA configurations and bandwidth combination sets defined for inter-band CA (five bands)**

E-UTRA CA configuration / Bandwidth combination set										
E-UTRA CA Configuration	Uplink CA configurations (NOTE 5)	E-UTRA Bands	1.4 MHz	3 MHz	5 MHz	10 MHz	15 MHz	20 MHz	Maximum aggregated bandwidth [MHz]	Bandwidth combination set
CA_1A-3A-5A-7A-28A	-	1			Yes	Yes	Yes		85	0
		3			Yes	Yes	Yes	Yes		
		5			Yes	Yes				
		7				Yes	Yes	Yes		
		28			Yes	Yes	Yes	Yes		
CA_1A-3A-7A-8A-20A	-	1			Yes	Yes	Yes	Yes	90	0
		3			Yes	Yes	Yes	Yes		
		7				Yes	Yes	Yes		
		8			Yes	Yes				
		20				Yes	Yes	Yes		
CA_1A-3A-7A-20A-28A <sup>7</sup>	-	1			Yes	Yes	Yes	Yes	100	0
		3			Yes	Yes	Yes	Yes		
		7				Yes	Yes	Yes		
		20				Yes	Yes	Yes		
		28			Yes	Yes	Yes	Yes		
CA_1A-3A-7A-20A-32A	-	1			Yes	Yes	Yes	Yes	100	0
		3			Yes	Yes	Yes	Yes		
		7				Yes	Yes	Yes		
		20			Yes	Yes	Yes	Yes		
		32			Yes	Yes	Yes	Yes		
CA_1A-3A-7A-20A-42A	-	1			Yes	Yes	Yes	Yes	100	0
		3			Yes	Yes	Yes	Yes		
		7				Yes	Yes	Yes		
		20			Yes	Yes	Yes	Yes		
		42			Yes	Yes	Yes	Yes		
CA_1A-3A-8A-11A-28A	-	1			Yes	Yes	Yes	Yes	80	0
		3			Yes	Yes	Yes	Yes		
		8			Yes	Yes				
		11			Yes	Yes				
		28			Yes	Yes	Yes	Yes		
CA_1A-3A-20A-32A-42A	-	1			Yes	Yes	Yes		75	0
		3			Yes	Yes	Yes			
		20			Yes					
		32			Yes	Yes	Yes	Yes		
		42			Yes	Yes	Yes	Yes		
CA_1A-3A-20A-32A-43A	-	1			Yes	Yes	Yes		75	0
		3			Yes	Yes	Yes			
		20			Yes					
		32			Yes	Yes	Yes	Yes		
		43			Yes	Yes	Yes	Yes		
CA_1A-3A-32A-42A-43A	-	1			Yes	Yes	Yes		90	0
		3			Yes	Yes	Yes			
		32			Yes	Yes	Yes	Yes		
		42			Yes	Yes	Yes	Yes		
		43			Yes	Yes	Yes	Yes		

NOTE 1: The CA Configuration refers to a combination of an operating band and a CA bandwidth class specified in Table 5.6A-1 (the indexing letter). Absence of a CA bandwidth class for an operating band implies support of all classes.

NOTE 2: For each band combination, all combinations of indicated bandwidths belong to the set.

NOTE 3: For the supported CC bandwidth combinations, the CC downlink and uplink bandwidths are equal.

NOTE 4: A terminal which supports a DL CA configuration shall support all the lower order fallback DL CA combinations and it shall support at least one bandwidth combination set for each of the constituent lower order DL combinations containing all the bandwidths specified within each specific combination set of the upper order DL combination.

NOTE 5: Uplink CA configurations are the configurations supported by the present release of specifications.

NOTE 6: If the UE supports uplink CA for corresponding downlink CA it shall support this uplink CA configuration.

NOTE 7: Power imbalance between downlink carriers on Band 20 and Band 28 is assumed to be within [6dB].

**Table 5.6A.1-3: E-UTRA CA configurations and bandwidth combination sets defined for non-contiguous intra-band CA (with two sub-blocks)**

E-UTRACA configuration	Uplink CA configurations (NOTE 1)	E-UTRA CA configuration / Bandwidth combination set						
		Component carriers in order of increasing carrier frequency					Maximum aggregated bandwidth [MHz]	Bandwidth combination set
		Channel bandwidths for carrier [MHz]	Channel bandwidths for carrier [MHz]	Channel bandwidths for carrier [MHz]	Channel bandwidths for carrier [MHz]	Channel bandwidths for carrier [MHz]		
CA_1A-1A	-	5, 10, 15, 20	5, 10, 15, 20				40	0
CA_2A-2A	-	5, 10, 15, 20	5, 10, 15, 20				40	0
CA_3A-3A	-	5, 10, 15, 20	5, 10, 15, 20				40	0
		5, 10	5, 10, 15, 20				30	1
		5	3				10	2
		3, 5	5					
CA_4A-4A	CA_4A-4A	5, 10, 15, 20	5, 10, 15, 20				40	0
		5, 10	5, 10				20	1
CA_5A-5A	-	5,10	5,10				20	0
		3	5				8	1
CA_7A-7A	-	5	15				40	0
		10	10, 15					
		15	15, 20					
		20	20				40	1
		5, 10, 15, 20	5, 10, 15, 20				30	2
		10, 15, 20	10, 15, 20				40	3
CA_12A-12A	-	5	5				10	0
CA_23A-23A	-	5	10				15	0
CA_25A-25A	-	5, 10	5, 10				20	0
		5, 10, 15, 20	5, 10, 15, 20				40	1
CA_40A-40A	-	10, 20	10, 20				40	0
		10,15,20	10,15,20				40	1
CA_40A-40C	CA_40C	20	See CA_40C Bandwidth Combination Set 1 in Table 5.6A.1-1				60	0
		See CA_40C Bandwidth Combination Set 1 in Table 5.6A.1-1		20				
CA_40C-40C	CA_40C	See CA_40C Bandwidth Combination Set 1 in Table 5.6A.1-1		See CA_40C Bandwidth Combination Set 1 in Table 5.6A.1-1			80	0
CA_41A-41A	-	10, 15, 20	10, 15, 20				40	0
		5, 10, 15, 20	5, 10, 15, 20				40	1
CA_41A-41C	CA_41C	5, 10, 15, 20	See CA_41C Bandwidth Combination Set 1 in Table 5.6A.1-1				60	0
		See CA_41C Bandwidth Combination Set 1 in Table 5.6A.1-1		5, 10, 15, 20				



CA_41A-41D	CA_41C	5, 10, 15, 20	See CA_41D Bandwidth Combination Set 0 in Table 5.6A.1-1		80	0	
		See CA_41D Bandwidth Combination Set 0 in Table 5.6A.1-1		5, 10, 15, 20			
CA_41C-41C	CA_41C	See CA_41C Bandwidth Combination Set 0 in Table 5.6A.1-1	See CA_41C Bandwidth Combination Set 0 in Table 5.6A.1-1		80	0	
CA_41C-41D	CA_41C	See CA_41C Bandwidth Combination Set 0 in Table 5.6A.1-1	See CA_41D Bandwidth Combination Set 0 in Table 5.6A.1-1			100	0
		See CA_41D Bandwidth Combination Set 0 in Table 5.6A.1-1		See CA_41C Bandwidth Combination Set 0 in Table 5.6A.1-1			
CA_42A-42A	-	5, 10, 15, 20	5, 10, 15, 20		40	0	
		10, 15, 20	10, 15, 20		40	1	
CA_42A-42C	CA_42C	5, 10, 15, 20	See CA_42C Bandwidth Combination Set 0 in Table 5.6A.1-1		60	0	
		See CA_42C Bandwidth Combination Set 0 in Table 5.6A.1-1		5, 10, 15, 20			
		10, 15, 20	See CA_42C Bandwidth Combination Set 1 in Table 5.6A.1-1		60	1	
		See CA_42C Bandwidth Combination Set 1 in Table 5.6A.1-1		10, 15, 20			
CA_42A-42D	-	5, 10, 15, 20	See CA_42D Bandwidth Combination Set 0 in Table 5.6A.1-1		80	0	
		See CA_42D Bandwidth Combination Set 0 in Table 5.6A.1-1		5, 10, 15, 20			
CA_42C-42C	CA_42C	See CA_42C Bandwidth Combination Set 0 in Table 5.6A.1-1	See CA_42C Bandwidth Combination Set 0 in Table 5.6A.1-1		80	0	
		See CA_42C Bandwidth Combination Set 1 in Table 5.6A.1-1	See CA_42C Bandwidth Combination Set 1 in Table 5.6A.1-1		80	1	
CA_43A-43A	-	5, 10, 15, 20	5, 10, 15, 20		40	0	
CA_46A-46A <sup>2</sup>	-	20	20		40	0	
CA_46A-46C <sup>2</sup>	-	20	See CA_46C Bandwidth Combination Set 0 in Table 5.6A.1-1		60	0	
		See CA_46C Bandwidth Combination Set 0 in Table 5.6A.1-1		20			
CA_46A-46D <sup>2</sup>	-	20	See CA_46D Bandwidth Combination Set 0 in Table 5.6A.1-1			80	0
		See CA_46D Bandwidth Combination Set 0 in Table 5.6A.1-1		20			
CA_48A-48A	-	5, 10, 15, 20	5, 10, 15, 20		40	0	
CA_48A-48C	-	5, 10, 15, 20	See CA_48C Bandwidth Combination Set 0 in Table 5.6A.1-1		60	0	
		See CA_48C Bandwidth Combination Set 0 in Table 5.6A.1-1		5, 10, 15, 20			
CA_48A-48D	-	5, 10, 15, 20	See CA_48D Bandwidth Combination Set 0 in Table 5.6A.1-1		80	0	
		See CA_48D Bandwidth Combination Set 0 in Table 5.6A.1-1		5, 10, 15, 20			
CA_48C-48C	CA_48C	See CA_48C Bandwidth Combination Set 0 in Table 5.6A.1-1	See CA_48C Bandwidth Combination Set 0 in Table 5.6A.1-1		80	0	

CA_48C-48D	-	See CA_48C Bandwidth Combination Set 0 in Table 5.6A.1-1		See CA_48D Bandwidth Combination Set 0 in Table 5.6A.1-1		100	0
		See CA_48D Bandwidth Combination Set 0 in Table 5.6A.1-1		See CA_48C Bandwidth Combination Set 0 in Table 5.6A.1-1			
CA_48A-48E	-	5, 10, 15, 20	See CA_48E Bandwidth Combination Set 0 in Table 5.6A.1-1			100	0
		See CA_48E Bandwidth Combination Set 0 in Table 5.6A.1-1			5, 10, 15, 20		
CA_66A-66A	-	5, 10, 15, 20	5, 10, 15, 20			40	0
CA_66A-66B	-	5, 10, 15, 20	See CA_66B Bandwidth Combination Set 0 in Table 5.6A.1-1			40	0
		See CA_66B Bandwidth Combination Set 0 in Table 5.6A.1-1		5, 10, 15, 20			
CA_66A-66C	-	5, 10, 15, 20	See CA_66C Bandwidth Combination Set 0 in Table 5.6A.1-1			60	0
		See CA_66C Bandwidth Combination Set 0 in Table 5.6A.1-1		5, 10, 15, 20			

NOTE 1: Uplink CA configurations are the configurations supported by the present release of specifications.

NOTE 2: Restricted to E-UTRA operation when inter-band carrier aggregation is configured. The downlink operating band is paired with the uplink operating band (external) of the carrier aggregation configuration that is supporting the configured Pcell.

**Table 5.6A.1-4: E-UTRA CA configurations and bandwidth combination sets defined for non-contiguous intra-band CA (with three sub-blocks)**

		E-UTRA CA configuration / Bandwidth combination set						
E-UTRACA configuration	Uplink CA configurations (NOTE 1)	Component carriers in order of increasing carrier frequency					Maximum aggregated bandwidth [MHz]	Bandwidth combination set
		Channel bandwidths for carrier [MHz]	Channel bandwidths for carrier [MHz]	Channel bandwidths for carrier [MHz]	Channel bandwidths for carrier [MHz]	Channel bandwidths for carrier [MHz]		
CA_25A-25A-25A	-	5, 10, 15, 20	5, 10, 15, 20	5, 10, 15, 20			60	0
CA_41A-41A-41A	-	5, 10, 15, 20	5, 10, 15, 20	5, 10, 15, 20			60	0
CA_41A-41A-41C	CA_41C	5, 10, 15, 20	5, 10, 15, 20	See CA_41C Bandwidth Combination Set 1 in Table 5.6A.1-1			80	0
		5, 10, 15, 20	See CA_41C Bandwidth Combination Set 1 in Table 5.6A.1-1		5, 10, 15, 20			
		See CA_41C Bandwidth Combination Set 1 in Table 5.6A.1-1		5, 10, 15, 20	5, 10, 15, 20			
CA_48A-48A-48A	-	5, 10, 15, 20	5, 10, 15, 20	5, 10, 15, 20			60	0
CA_66A-66A-66A	-	5, 10, 15, 20	5, 10, 15, 20	5, 10, 15, 20			60	0

**Table 5.6A.1-5: E-UTRA CA configurations and bandwidth combination sets defined for non-contiguous intra-band CA (with four sub-blocks)**

		E-UTRA CA configuration / Bandwidth combination set						
E-UTRACA configuration	Uplink CA configurations (NOTE 1)	Component carriers in order of increasing carrier frequency					Maximum aggregated bandwidth [MHz]	Bandwidth combination set
		Channel bandwidths for carrier [MHz]	Channel bandwidths for carrier [MHz]	Channel bandwidths for carrier [MHz]	Channel bandwidths for carrier [MHz]	Channel bandwidths for carrier [MHz]		

CA_48A-48A-48A-48A	-	5, 10, 15, 20	5, 10, 15, 20	5, 10, 15, 20	5, 10, 15, 20		80	0
--------------------	---	---------------	---------------	---------------	---------------	--	----	---

## 5.6B Channel bandwidth for UL-MIMO

The requirements specified in subclause 5.6 are applicable to UE supporting UL-MIMO.

### 5.6B.1 Void

## 5.6C Channel bandwidth for Dual Connectivity

For E-UTRA DC bands specified in 5.5C, the corresponding E-UTRA CA configurations in 5.6A.1, i.e., dual uplink inter-band carrier aggregation with uplink assigned to two E-UTRA bands, are applicable to Dual Connectivity.

NOTE 1: Requirements for the dual connectivity configurations are defined in the section corresponding E-UTRA uplink CA configurations, unless otherwise specified.

NOTE 2: For TDD inter-band dual connectivity configurations, requirements are applicable only for synchronous operation.

### 5.6C.1 Void

**Table 5.6C.1-1: Void**

**Table 5.6C.1-2: Void**

## 5.6D Channel bandwidth for ProSe

### 5.6D.1 Channel bandwidths per operating band for ProSe

The ProSe combination of channel bandwidths and operating bands is shown in Table 5.6D.1-1 and Table 5.6D.1-2. The transmission bandwidth configuration in Table 5.6D.1-1 and Table 5.6D.1-2 shall be supported for each of the specified channel bandwidths. The same (symmetrical) channel bandwidth is specified for both the TX and RX path.

Table 5.6D.1-1 ProSe Direct Discovery channel bandwidth

E-UTRA ProSe band / ProSe channel bandwidth						
E-UTRA ProSe Band	1.4 MHz	3 MHz	5 MHz	10 MHz	15 MHz	20 MHz
2			Yes	Yes	Yes	Yes
3			Yes	Yes	Yes	Yes
4			Yes	Yes	Yes	Yes
7			Yes	Yes	Yes	Yes
14			Yes	Yes		
20			Yes	Yes	Yes	Yes
26			Yes	Yes	Yes	
28			Yes	Yes	Yes	Yes
31			Yes			
41			Yes	Yes	Yes	Yes
68			Yes	Yes	Yes	
72			Yes			

Table 5.6D.1-2 ProSe Direct Communication channel bandwidth

E-UTRA ProSe band / ProSe channel bandwidth						
E-UTRA ProSe Band	1.4 MHz	3 MHz	5 MHz	10 MHz	15 MHz	20 MHz
3				Yes		
7				Yes		
14				Yes		
20				Yes		
26				Yes		
28				Yes		
31			Yes			
68			Yes	Yes		
72			Yes			

## 5.6F Channel bandwidth for category NB1 and NB2

Channel bandwidth for Category NB1 and NB2 is 200 kHz.

For category NB1 and NB2, requirements in present document are specified for the channel bandwidth listed in Table 5.6F-1.

**Table 5.6F-1: Transmission bandwidth configuration  $M_{RB}$ ,  $N_{tone\ 15kHz}$  and  $N_{tone\ 3.75kHz}$  in NB1 and NB2 channel bandwidth**

Channel bandwidth $BW_{Channel}$ [kHz]	200
Transmission bandwidth configuration $N_{RB}$	1
Transmission bandwidth configuration $N_{tone\ 15kHz}$	12
Transmission bandwidth configuration $N_{tone\ 3.75kHz}$	48

Figure 5.6F-1 shows the relation between the Category NB1/NB2 channel bandwidth ( $BW_{Channel}$ ) and the Category NB1/NB2 transmission bandwidth configuration ( $N_{tone}$ ). The channel edges are defined as the lowest and highest frequencies of the carrier separated by the channel bandwidth, i.e. at  $F_C \pm BW_{Channel} / 2$ .

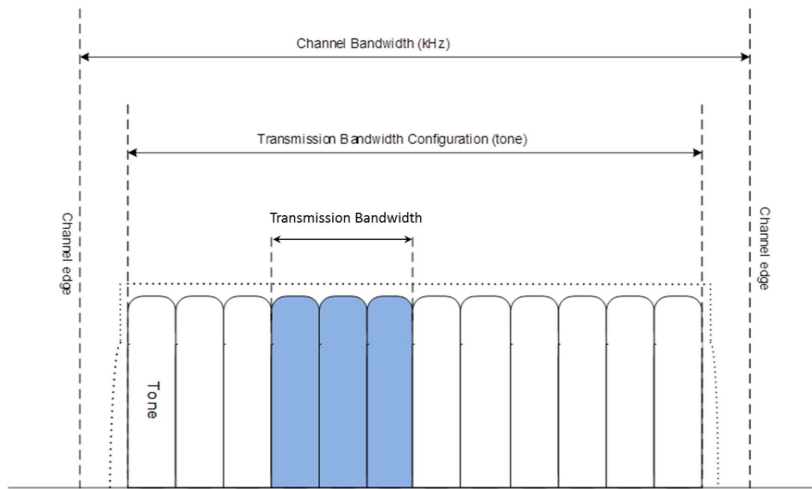

Figure 5.6F-1 Definition of Channel Bandwidth and Transmission Bandwidth configuration

## 5.6G Channel bandwidth for V2X Communication

### 5.6G.1 Channel bandwidths per operating band for V2X Communication

E-UTRA V2X Communication channel bandwidths and operating band is shown in Table 5.6G.1-1. The same (symmetrical) channel bandwidth is specified for both the TX and RX path.

Table 5.6G.1-1: V2X Communication channel bandwidth

E-UTRA V2X Operating Band	E-UTRA V2X band / V2X channel bandwidth					
	1.4 MHz	3 MHz	5 MHz	10 MHz	15 MHz	20 MHz
47				Yes		Yes

For V2X inter-band con-current operation, the V2X Communication channel bandwidths for each operating band is specified in Table 5.6G.1-2.

Table 5.6G.1-2: Inter-band con-current V2X configurations and bandwidth combination sets

Inter-band con-current V2X configuration	Inter-band con-current V2X configuration for TX	E-UTRA or V2X operating Bands	1.4 MHz	3 MHz	5 MHz	10 MHz	15 MHz	20 MHz	Maximum bandwidth [MHz]	Bandwidth combination set
V2X_3A-47A	V2X_3A-47A	3	Yes	Yes	Yes	Yes	Yes	Yes	40	0
		47				Yes		Yes		
V2X_3A-47B	V2X_3A-47A, V2X_47B	3	Yes	Yes	Yes	Yes	Yes	Yes	40	0
		47	See V2X_47B Bandwidth combination set 0 in Table 5.6G.1-4							
V2X_5A-47A	V2X_5A-47A	5			Yes	Yes			30	0
		47				Yes		Yes		
V2X_5A-47B	V2X_5A-47A, V2X_47B	5	Yes	Yes	Yes	Yes	Yes	Yes	40	0
		47	See V2X_47B Bandwidth combination set 0 in Table 5.6G.1-4							
V2X_7A_47A	V2X_7A_47A	7			Yes	Yes	Yes	Yes	40	0
		47				Yes		Yes		
V2X_7A-47B	V2X_7A-47A, V2X_47B	7			Yes	Yes	Yes	Yes	40	0
		47	See V2X_47B Bandwidth combination set 0 in Table 5.6G.1-4							
V2X_8A-47A	V2X_8A-47A	8	Yes	Yes	Yes	Yes			30	0
		47				Yes		Yes		
V2X_8A-47B	V2X_8A-47A, V2X_47B	8	Yes	Yes	Yes	Yes			40	0
		47	See V2X_47B Bandwidth combination set 0 in Table 5.6G.1-4							
V2X_20A-47A	V2X_20A-47A	20			Yes	Yes	Yes	Yes	40	0
		47				Yes		Yes		
V2X_20A-47B	V2X_20A-47A, V2X_47B	20			Yes	Yes	Yes	Yes	40	0
		47	See V2X_47B Bandwidth combination set 0 in Table 5.6G.1-4							
V2X_28A-47A		28		Yes	Yes	Yes	Yes	Yes	40	0
		47				Yes		Yes		
V2X_34A-47A	V2X_34A-47A	34			Yes	Yes	Yes		35	0
		47				Yes		Yes		
V2X_34A-47B	V2X_34A-47A, V2X_47B	34			Yes	Yes	Yes		40	0
		47	See V2X_47B Bandwidth combination set 0 in Table 5.6G.1-4							
V2X_39A-47A	V2X_39A-47A	39			Yes	Yes	Yes	Yes	40	0
		47				Yes		Yes		
V2X_39A-47B	V2X_39A-47A, V2X_47B	39			Yes	Yes	Yes	Yes	40	0
		47	See V2X_47B Bandwidth combination set 0 in Table 5.6G.1-4							
V2X_39A-47C	V2X_39A-47A, V2X_47C	39			Yes	Yes	Yes	Yes	50	0
		47	See V2X_47C Bandwidth combination set 0 in Table 5.6G.1-4							
V2X_41A-47A	V2X_41A-47	41			Yes	Yes	Yes	Yes	40	0
		47				Yes		Yes		
V2X_41A-47B	V2X_41A-47A, V2X_47B	41			Yes	Yes	Yes	Yes	40	0
		47	See V2X_47B Bandwidth combination set 0 in Table 5.6G.1-4							
V2X_41A-47C	V2X_41A-47A, V2X_47C	41			Yes	Yes	Yes	Yes	50	0
		47	See V2X_47C Bandwidth combination set 0 in Table 5.6G.1-4							
V2X_71A-47A		71			Yes	Yes	Yes	Yes	40	0
		47				Yes		Yes		

V2X Bandwidth Class is specified in Table 5.6G.1-3 for V2X intra-band contiguous multi-carrier operation.

Table 5.6G.1-3: V2X bandwidth classes and corresponding nominal guard bands

V2X Bandwidth Class	Aggregated Transmission Bandwidth Configuration	Number of contiguous CC	Nominal Guard Band BW <sub>GB</sub>
A	$N_{RB,agg} \leq 100$	1	$0.05BW_{Channel(1)} - 0.5\Delta f_1$
B	$25 < N_{RB,agg} \leq 100$	2	$[0.05 \max(BW_{Channel(1)}, BW_{Channel(2)}) - 0.5\Delta f_1]$
C	$100 < N_{RB,agg} \leq 200$	2	$[0.05 \max(BW_{Channel(1)}, BW_{Channel(2)}) - 0.5\Delta f_1]$
C <sub>1</sub>	$100 < N_{RB,agg} \leq 200$	3	$[0.05 \max(BW_{Channel(1)}, BW_{Channel(2)}) - 0.5\Delta f_1]$
D	$200 < N_{RB,agg} \leq 300$	3	NOTE 3
E	$300 < N_{RB,agg} \leq 400$	4	NOTE 3
F	$400 < N_{RB,agg} \leq 500$	5	NOTE 3
I	$700 < N_{RB,agg} \leq 800$	8	NOTE 3

NOTE 1:  $BW_{Channel(j)}$ ,  $j = 1, 2, 3, 4$  is the channel bandwidth of an E-UTRA component carrier according to Table 5.6-1 and  $\Delta f_1 = \Delta f$  for the downlink with  $\Delta f$  the subcarrier spacing while  $\Delta f_1 = 0$  for the uplink.  
NOTE 2: Void  
NOTE 3: Applicable for later releases.

For V2X intra-band multi-carrier operation, the V2X communication channel bandwidths for each operating band is specified in Table 5.6G.1-4.

Table 5.6G.1-4: V2X intra-band multi-carrier configurations

V2X intra-band multi-carrier configuration	V2X intra-band multi-carrier configuration for TX	V2X multi-carrier configuration / Bandwidth combination set						
		Component carriers in order of increasing carrier frequency					Maximum aggregated bandwidth [MHz]	Bandwidth combination set
		Channel bandwidths for carrier [MHz]	Channel bandwidths for carrier [MHz]	Channel bandwidths for carrier [MHz]	Channel bandwidths for carrier [MHz]	Channel bandwidths for carrier [MHz]		
V2X_47B	V2X_47B	10	10				20	0
V2X_47C	V2X_47C	10	20				30	0
		20	10					
V2X_47C1	V2X_47B	10	10	10			30	0

## 5.7 Channel arrangement

### 5.7.1 Channel spacing

The spacing between carriers will depend on the deployment scenario, the size of the frequency block available and the channel bandwidths. The nominal channel spacing between two adjacent E-UTRA carriers is defined as following:

$$\text{Nominal Channel spacing} = (BW_{Channel(1)} + BW_{Channel(2)})/2$$

where  $BW_{Channel(1)}$  and  $BW_{Channel(2)}$  are the channel bandwidths of the two respective E-UTRA carriers. The channel spacing can be adjusted to optimize performance in a particular deployment scenario.

#### 5.7.1A Channel spacing for CA

For intra-band contiguous carrier aggregation with two or more component carriers, the nominal channel spacing between two adjacent E-UTRA component carriers is defined as the following unless stated otherwise:

$$\text{Nominal channel spacing} = \left\lceil \frac{BW_{\text{Channel}(1)} + BW_{\text{Channel}(2)} - 0.1|BW_{\text{Channel}(1)} - BW_{\text{Channel}(2)}|}{0.6} \right\rceil 0.3 \text{ [MHz]}$$

where  $BW_{\text{Channel}(1)}$  and  $BW_{\text{Channel}(2)}$  are the channel bandwidths of the two respective E-UTRA component carriers according to Table 5.6-1 with values in MHz. The channel spacing for intra-band contiguous carrier aggregation can be adjusted to any multiple of 300 kHz less than the nominal channel spacing to optimize performance in a particular deployment scenario.

For intra-band contiguous carrier aggregation with two or more component carriers in Band 46, the requirements apply for both 19.8 MHz and 20.1 MHz nominal carrier spacing between two 20 MHz component carriers, and for 15.0 MHz nominal carrier spacing between 10 MHz and 20 MHz component carriers.

For intra-band non-contiguous carrier aggregation the channel spacing between two or more E-UTRA component carriers in different sub-blocks shall be larger than the nominal channel spacing defined in this subclause.

### 5.7.1F Channel spacing for category NB1 and NB2

Nominal channel spacing for UE category NB1 and NB2 in stand-alone mode is 200 kHz. For in-band and guard-band cases the nominal channel spacing between two adjacent category NB1 or NB2 carriers is 180 kHz.

### 5.7.2 Channel raster

The channel raster is 100 kHz for all bands, which means that the carrier centre frequency must be an integer multiple of 100 kHz.

#### 5.7.2A Channel raster for CA

For carrier aggregation the channel raster is 100 kHz for all bands, which means that the carrier centre frequency must be an integer multiple of 100 kHz.

### 5.7.2F Channel raster for category NB1 and NB2

Channel raster for category NB1 and NB2 in-band, guard-band and standalone operation is 100 kHz.

### 5.7.3 Carrier frequency and EARFCN

The carrier frequency in the uplink and downlink is designated by the E-UTRA Absolute Radio Frequency Channel Number (EARFCN) in the range 0 – 262143. The relation between EARFCN and the carrier frequency in MHz for the downlink is given by the following equation, where  $F_{\text{DL\_low}}$  and  $N_{\text{Offs-DL}}$  are given in Table 5.7.3-1 and  $N_{\text{DL}}$  is the downlink EARFCN.

$$F_{\text{DL}} = F_{\text{DL\_low}} + 0.1(N_{\text{DL}} - N_{\text{Offs-DL}})$$

The relation between EARFCN and the carrier frequency in MHz for the uplink is given by the following equation where  $F_{\text{UL\_low}}$  and  $N_{\text{Offs-UL}}$  are given in Table 5.7.3-1 and  $N_{\text{UL}}$  is the uplink EARFCN.

$$F_{\text{UL}} = F_{\text{UL\_low}} + 0.1(N_{\text{UL}} - N_{\text{Offs-UL}})$$



**Table 5.7.3-1: E-UTRA channel numbers**

E-UTRA Operating Band	Downlink			Uplink		
	F <sub>DL_low</sub> (MHz)	N <sub>offs-DL</sub>	Range of N <sub>DL</sub>	F <sub>UL_low</sub> (MHz)	N <sub>offs-UL</sub>	Range of N <sub>UL</sub>
1	2110	0	0 – 599	1920	18000	18000 – 18599
2	1930	600	600 – 1199	1850	18600	18600 – 19199
3	1805	1200	1200 – 1949	1710	19200	19200 – 19949
4	2110	1950	1950 – 2399	1710	19950	19950 – 20399
5	869	2400	2400 – 2649	824	20400	20400 – 20649
6	875	2650	2650 – 2749	830	20650	20650 – 20749
7	2620	2750	2750 – 3449	2500	20750	20750 – 21449
8	925	3450	3450 – 3799	880	21450	21450 – 21799
9	1844.9	3800	3800 – 4149	1749.9	21800	21800 – 22149
10	2110	4150	4150 – 4749	1710	22150	22150 – 22749
11	1475.9	4750	4750 – 4949	1427.9	22750	22750 – 22949
12	729	5010	5010 – 5179	699	23010	23010 – 23179
13	746	5180	5180 – 5279	777	23180	23180 – 23279
14	758	5280	5280 – 5379	788	23280	23280 – 23379
...						
17	734	5730	5730 – 5849	704	23730	23730 – 23849
18	860	5850	5850 – 5999	815	23850	23850 – 23999
19	875	6000	6000 – 6149	830	24000	24000 – 24149
20	791	6150	6150 – 6449	832	24150	24150 – 24449
21	1495.9	6450	6450 – 6599	1447.9	24450	24450 – 24599
22	3510	6600	6600 – 7399	3410	24600	24600 – 25399
23	2180	7500	7500 – 7699	2000	25500	25500 – 25699
24	1525	7700	7700 – 8039	1626.5	25700	25700 – 26039
25	1930	8040	8040 – 8689	1850	26040	26040 – 26689
26	859	8690	8690 – 9039	814	26690	26690 – 27039
27	852	9040	9040 – 9209	807	27040	27040 – 27209
28	758	9210	9210 – 9659	703	27210	27210 – 27659
29 <sup>2</sup>	717	9660	9660 – 9769		N/A	
30	2350	9770	9770 – 9869	2305	27660	27660 – 27759
31	462.5	9870	9870 – 9919	452.5	27760	27760 – 27809
32 <sup>2</sup>	1452	9920	9920 – 10359		N/A	
33	1900	36000	36000 – 36199	1900	36000	36000 – 36199
34	2010	36200	36200 – 36349	2010	36200	36200 – 36349
35	1850	36350	36350 – 36949	1850	36350	36350 – 36949
36	1930	36950	36950 – 37549	1930	36950	36950 – 37549
37	1910	37550	37550 – 37749	1910	37550	37550 – 37749
38	2570	37750	37750 – 38249	2570	37750	37750 – 38249
39	1880	38250	38250 – 38649	1880	38250	38250 – 38649
40	2300	38650	38650 – 39649	2300	38650	38650 – 39649
41	2496	39650	39650 – 41589	2496	39650	39650 – 41589
42	3400	41590	41590 – 43589	3400	41590	41590 – 43589
43	3600	43590	43590 – 45589	3600	43590	43590 – 45589
44	703	45590	45590 – 46589	703	45590	45590 – 46589
45	1447	46590	46590 – 46789	1447	46590	46590 – 46789
46	5150	46790	46790 – 54539	5150	46790	46790 – 54539
47	5855	54540	54540 – 55239	5855	54540	54540 – 55239
48	3550	55240	55240 – 56739	3550	55240	55240 – 56739
49	3550	56740	56740 – 58239	3550	56740	56740 – 58239
50	1432	58240	58240 – 59089	1432	58240	58240 – 59089
51	1427	59090	59090 – 59139	1427	59090	59090 – 59139
52	3300	59140	59140 – 60139	3300	59140	59140 – 60139
53	2483.5	60140	60140 – 60254	2483.5	60140	60140 – 60254
...						
64			Reserved			
65	2110	65536	65536 – 66435	1920	131072	131072 – 131971
66 <sup>5</sup>	2110	66436	66436 – 67335	1710	131972	131972 – 132671
67 <sup>2</sup>	738	67336	67336 – 67535		N/A	
68	753	67536	67536 – 67835	698	132672	132672 – 132971
69 <sup>2</sup>	2570	67836	67836 – 68335		N/A	
70 <sup>6</sup>	1995	68336	68336 – 68585	1695	132972	132972 – 133121
71	617	68586	68586 – 68935	663	133122	133122 – 133471
72	461	68936	68936 – 68985	451	133472	133472 – 133521

73	460	68986	68986 - 69035	450	133522	133522 - 133571
74	1475	69036	69036 - 69465	1427	133572	133572 - 134001
75 <sup>2</sup>	1432	69466	69466 - 70315	N/A		
76 <sup>2</sup>	1427	70316	70316 - 70365	N/A		
85	728	70366	70366 - 70545	698	134002	134002 - 134181
87	420	70546	70546 - 70595	410	134182	134182 - 134231
88	422	70596	70596 - 70645	412	134232	134232 - 134281

NOTE 1: The channel numbers that designate carrier frequencies so close to the operating band edges that the carrier extends beyond the operating band edge shall not be used. This implies that the first 7, 15, 25, 50, 75 and 100 channel numbers at the lower operating band edge and the last 6, 14, 24, 49, 74 and 99 channel numbers at the upper operating band edge shall not be used for channel bandwidths of 1.4, 3, 5, 10, 15 and 20 MHz respectively.

NOTE 2: Restricted to E-UTRA operation when carrier aggregation is configured.

NOTE 3: For ProSe and V2X the corresponding UL channel number are also specified for the DL for the associated ProSe/V2X operating bands i.e. ProSe\_F<sub>UL</sub> = F<sub>UL</sub> and ProSe\_F<sub>DL</sub> = F<sub>UL</sub>; V2X\_F<sub>UL</sub> = F<sub>DL</sub> and V2X\_F<sub>DL</sub> = F<sub>UL</sub>.

NOTE 4: Requirements for uplink operations are not specified in this version of the specification.

NOTE 5: The range 2180-2200 MHz of the DL operating band is restricted to E-UTRA operation when carrier aggregation is configured.

NOTE 6: The range 2010-2020 MHz of the DL operating band is restricted to E-UTRA operation when carrier aggregation is configured and TX-RX separation is 300 MHz The range 2005-2020 MHz of the DL operating band is restricted to E-UTRA operation when carrier aggregation is configured and TX-RX separation is 295 MHz.

### 5.7.3F Carrier frequency and EARFCN for category NB1 and NB2

The carrier frequency of category NB1/NB2 in the downlink is designated by the E-UTRA Absolute Radio Frequency Channel Number (EARFCN) in the range 0 – 262143 and the Offset of category NB1/NB2 Channel Number to EARFCN in the range {-10,-9,-8,-7,-6,-5,-4,-3,-2,-1,-0.5,0,1,2,3,4,5,6,7,8,9} for FDD and in the range {-10,-9,-8.5,-8,-7,-6,-5,-4.5,-4,-3,-2,-1,-0.5,0,1,2,3,3.5,4,5,6,7,7.5,8,9} for TDD. The relation between EARFCN, Offset of category NB1/NB2 Channel Number to EARFCN and the carrier frequency in MHz for the downlink is given by the following equation, where F<sub>DL</sub> is the downlink carrier frequency of category NB1/NB2, F<sub>DL,low</sub> and N<sub>Offs-DL</sub> are given in table 5.7.3-1, N<sub>DL</sub> is the downlink EARFCN, M<sub>DL</sub> is the Offset of category NB1/NB2 Channel Number to downlink EARFCN.

$$F_{DL} = F_{DL,low} + 0.1(N_{DL} - N_{Offs-DL}) + 0.0025*(2M_{DL}+1)$$

The carrier frequency of category NB1/NB2 in the uplink is designated by the E-UTRA Absolute Radio Frequency Channel Number (EARFCN) in the range 0 – 262143, and the Offset of category NB1/NB2 Channel Number to EARFCN in the range {-10,-9,-8,-7,-6,-5,-4,-3,-2,-1,0,1,2,3,4,5,6,7,8,9} for FDD and in the range {-11,-10,-9.5,-9,-8.5,-8,-7.5,-7,-6.5,-6,-5.5,-5,-4.5,-4,-3.5,-3,-2.5,-2,-1.5,-1,-0.5,0,0.5,1,1.5,2,2.5,3,3.5,4,4.5,5,5.5,6,6.5,7,7.5,8,8.5,9,9.5,10,11} for TDD. The relation between EARFCN, Offset of category NB1/NB2 Channel Number to EARFCN and the carrier frequency in MHz for the uplink is given by the following equation, where F<sub>UL</sub> is the uplink carrier frequency of category NB1/NB2, F<sub>UL,low</sub> and N<sub>Offs-UL</sub> are given in table 5.7.3-1, N<sub>UL</sub> is the uplink EARFCN, M<sub>UL</sub> is the Offset of category NB1/NB2 Channel Number to uplink EARFCN.

$$F_{UL} = F_{UL,low} + 0.1(N_{UL} - N_{Offs-UL}) + 0.0025*(2M_{UL})$$

NOTE 1: For category NB1/NB2, N<sub>DL</sub> or N<sub>UL</sub> is different than the value of EARFCN that corresponds to E-UTRA downlink or uplink carrier frequency for in-band and guard band operation.

NOTE 2: For FDD M<sub>DL</sub> = -0.5 is not applicable for in-band and guard band operation. For TDD M<sub>DL</sub> {-0.5,+3.5,-4.5,+7.5,-8.5} is not applicable for in-band and guard band operation.

NOTE 3: For the carrier including NPSS/NSSS for in-band and guard band operation, M<sub>DL</sub> is selected from {-2,-1,0,1}.

NOTE 4: For the carrier including NPSS/NSSS for stand-alone operation, M<sub>DL</sub> = -0.5.

### 5.7.4 TX–RX frequency separation

a) The default E-UTRA TX channel (carrier centre frequency) to RX channel (carrier centre frequency) separation is specified in Table 5.7.4-1 for the TX and RX channel bandwidths defined in Table 5.6.1-1

Table 5.7.4-1: Default UE TX-RX frequency separation

E-UTRA Operating Band	TX – RX carrier centre frequency separation
1	190 MHz
2	80 MHz
3	95 MHz
4	400 MHz
5	45 MHz
6	45 MHz
7	120 MHz
8	45 MHz
9	95 MHz
10	400 MHz
11	48 MHz
12	30 MHz
13	-31 MHz
14	-30 MHz
17	30 MHz
18	45 MHz
19	45 MHz
20	-41 MHz
21	48 MHz
22	100 MHz
23	180 MHz
24	-101.5 MHz
25	80 MHz
26	45 MHz
27	45 MHz
28	55 MHz
30	45 MHz
31	10 MHz
65	190 MHz
66	400 MHz
68	55 MHz
...	
70	295, 300MHz <sup>1</sup>
71	-46 MHz
72	10 MHz
73	10 MHz
74	48 MHz
85	30 MHz
87	10 MHz
88	10 MHz

NOTE 1: Default TX-RX carrier centre frequency separation.

b) The use of other TX channel to RX channel carrier centre frequency separation is not precluded and is intended to form part of a later release.

#### 5.7.4A TX–RX frequency separation for CA

For intra-band contiguous carrier aggregation, the same TX-RX frequency separation as specified in Table 5.7.4-1 is applied to PCC and SCC, respectively.

#### 5.7.4E TX–RX frequency separation for category M1 and M2

For the category M1 and M2 TX-RX frequency separation is flexible within the assigned channel bandwidth of E-UTRA carrier with the TX-RX frequency separation of the E-UTRA carriers as specified in Table 5.7.4-1.

## 5.7.4F TX–RX frequency separation for category NB1 and NB2

For in-band and guard-band operation mode, the category NB1 and NB2 TX-RX frequency separation is flexible within the assigned channel bandwidth of E-UTRA carrier with the TX-RX frequency separation of the E-UTRA carriers as specified in Table 5.7.4-1. For stand-alone operation mode the default TX-RX frequency separation is the same as Table 5.7.4-1.

---

# 6 Transmitter characteristics

## 6.1 General

Unless otherwise stated, the transmitter characteristics are specified at the antenna connector of the UE with a single or multiple transmit antenna(s). For UE with integral antenna only, a reference antenna with a gain of 0 dBi is assumed.

Unless otherwise stated, NB1 and NB2 requirements specified for an E-UTRA band shall also apply for the re-farmed NR band (e.g. if NB1/NB2 requirements are specified for E-UTRA band 1, they shall also apply for NR band n1).

## 6.2 Transmit power

### 6.2.1 Void

### 6.2.2 UE maximum output power

The following UE Power Classes define the maximum output power for any transmission bandwidth within the channel bandwidth for non CA configuration unless otherwise stated. The period of measurement shall be at least as defined in Table 6.2.2-0.

**Table 6.2.2-0: Measurement period for UE maximum output power**

TTI pattern	Minimum measurement period
Subframe	1ms
Slot	7OS
Subslot	2OS, 3OS

**Table 6.2.2-1: UE Power Class**

EUTRA band	Class 1 (dBm)	Tolerance (dB)	Class 2 (dBm)	Tolerance (dB)	Class 3 (dBm)	Tolerance (dB)	Class 4 (dBm)	Tolerance (dB)
1					23	$\pm 2$		
2					23	$\pm 2^2$		
3	31	+2/-3			23	$\pm 2^2$		
4					23	$\pm 2$		
5					23	$\pm 2$		
6					23	$\pm 2$		
7					23	$\pm 2^2$		
8					23	$\pm 2^2$		
9					23	$\pm 2$		
10					23	$\pm 2$		
11					23	$\pm 2$		
12					23	$\pm 2^2$		
13					23	$\pm 2$		
14	31	+2/-3			23	$\pm 2$		
17					23	$\pm 2$		
18					23	$\pm 2^5$		
19					23	$\pm 2$		
20	31	+2/-3			23	$\pm 2^2$		
21					23	$\pm 2$		
22					23	+2/-3.5 <sup>2</sup>		
23					23 <sup>6</sup>	$\pm 2^6$		
24					23	$\pm 2$		
25					23	$\pm 2^2$		
26					23	$\pm 2^2$		
27					23	$\pm 2$		
28	31	+2/-3			23	+2/-2.5		
30					23	$\pm 2$		
31	31	+2/-3			23	$\pm 2$		
...								
33					23	$\pm 2$		
34					23	$\pm 2$		
35					23	$\pm 2$		
36					23	$\pm 2$		
37					23	$\pm 2$		
38			26	$\pm 2$	23	$\pm 2$		
39					23	$\pm 2$		
40			26	$\pm 2$	23	$\pm 2$		
41			26	$\pm 2^2$	23	$\pm 2^2$		
42			26	+2/-3	23	+2/-3		
43					23	+2/-3		
44					23	+2/[-3]		
45					23	$\pm 2$		
...								
47			26	$\pm 2$	23	$\pm 2$		
48					23	+2/-3		
50					23	$\pm 2$		
51					23	$\pm 2$		
52					23	+2/-3		
53					23	$\pm 2$		
65					23	$\pm 2$		
66					23	$\pm 2$		
68					23	$\pm 2$		
...								
70					23	$\pm 2$		
71					23	+2/-2.5		
72	31	+2/-3			23	$\pm 2$		
73					23	$\pm 2$		
74					23	$\pm 2$		
85					23	$\pm 2^2$		
87	31	+2/-3			23	$\pm 2$		
88	31	+2/-3			23	$\pm 2$		

NOTE 1:	Void
NOTE 2:	<sup>2</sup> refers to the transmission bandwidths (Figure 5.6-1) confined within $F_{UL,low}$ and $F_{UL,low} + 4$ MHz or $F_{UL,high} - 4$ MHz and $F_{UL,high}$ , the maximum output power requirement is relaxed by reducing the lower tolerance limit by 1.5 dB
NOTE 3:	For the UE which supports both Band 11 and Band 21 operating frequencies, the tolerance is FFS.
NOTE 4:	$P_{PowerClass}$ is the maximum UE power specified without taking into account the tolerance
NOTE 5:	For a UE that supports both Band 18 and Band 26, the maximum output power requirement is relaxed by reducing the lower tolerance limit by 1.5 dB for transmission bandwidths confined within 815 MHz and 818 MHz.
NOTE 6:	When NS_20 is signalled, the total output power within 2000-2005 MHz shall be limited to 7 dBm.
NOTE 7:	Void.
NOTE 8:	Generally, PC1 UE is not targeted for smartphone form factor.
NOTE 9:	Void.

The default power class  $P_{PowerClass\_Default}$  for an operating band is Power Class 3 unless otherwise stated.

For a power class 2 capable UE operating on Band 41, when an IE  $P_{max}$  as defined in TS 36.331 [7] of 23 dBm or lower is indicated in the cell or if the uplink/downlink configuration is 0 or 6, the requirements for power class 2 are not applicable, and the corresponding requirements for a power class 3 UE shall apply.

For each supported frequency band other than Band 41, the UE shall:

- if the UE supports a different power class than the default UE power class for the band and the supported power class enables the higher maximum output power than that of the default power class:
  - if the band is a TDD band whose frame configuration is 0 or 6; or
  - if the IE  $P_{Max}$  as defined in TS 36.331 [7] is not provided; or
  - if the IE  $P_{Max}$  as defined in TS 36.331 [7] is provided and set to the maximum output power of the default power class or lower;
    - meet all requirements for the default power class of the operating band in which the UE is operating and set its configured transmitted power as specified in sub-clause 6.2.5;
  - else (i.e the IE  $P_{Max}$  as defined in TS 36.331 [7] is provided and set to the higher value than the maximum output power of the default power class):
    - meet all requirements for the supported power class and set its configured transmitted power class as specified in sub-clause 6.2.5;

## 6.2.2A UE maximum output power for CA

The following UE Power Classes define the maximum output power for any transmission bandwidth within the aggregated channel bandwidth.

The maximum output power is measured as the sum of the maximum output power at each UE antenna connector. The period of measurement shall be at least as defined in Table 6.2.2A-0a.

**Table 6.2.2A-0a: Measurement period for UE maximum output power for CA**

TTI pattern	Minimum measurement period
Subframe	1ms
Slot	7OS
Subslot	2OS, 3OS

For inter-band carrier aggregation with one uplink component carrier assigned to one E-UTRA band the requirements in subclause 6.2.2 apply. For inter-band carrier aggregation with two uplink contiguous component carrier assigned to one E-UTRA band the requirements specified in Table 6.2.2A-1 apply for that band. For inter-band carrier aggregation with one uplink component carrier assigned to one E-UTRA band in Band 38, 40, 41 or 42, the requirements for power class 2 are not applicable and the corresponding requirements for a power class 3 UE shall apply. For inter-band carrier aggregation with one uplink component carrier assigned to one E-UTRA band in Band 3, 20, 28, or 31, the



requirements for power class 1 are not applicable and the corresponding requirements for a power class 3 UE shall apply.

For inter-band carrier aggregation with uplink assigned to two E-UTRA bands, UE maximum output power shall be measured over all component carriers from different bands. If each band has separate antenna connectors, maximum output power is measured as the sum of maximum output power at each UE antenna connector. The maximum output power is specified in Table 6.2.2A-0.

For E-UTRA CA bands including an uplink LAA Scell in Band 46, the UE shall meet the following additional requirements for transmission within the frequency ranges 5150-5350 MHz and 5470-5725 MHz:

- a maximum mean power density of 10 dBm in any 1 MHz band when the network signaling value NS\_28 or NS\_29 is indicated in the LAA Scell;
- a maximum mean power density of 11 dBm in any 1 MHz band when the network signaling value NS\_30 is indicated in the LAA Scell;

the following additional requirements for transmission within the frequency range 5230-5250 MHz:

- a maximum mean power density of 4 dBm in any 1 MHz band when the network signaling value NS\_31 is indicated in the LAA Scell;

the following additional requirements for transmission within the frequency ranges 5150-5230 MHz, 5250-5350 MHz, 5470-5725 MHz and 5725-5850 MHz:

- a maximum mean power density of 10 dBm in any 1 MHz band when the network signaling value NS\_31 is indicated in the LAA Scell;

where the said network signaling values are specified in clause 6.2.4.

**Table 6.2.2A-0: UE Power Class for uplink interband CA (two bands)**

E-UTRA CA Configuration	Class 1 (dBm)	Tolerance (dB)	Class 2 (dBm)	Tolerance (dB)	Class 3 (dBm)	Tolerance (dB)	Class 4 (dBm)	Tolerance (dB)
CA_1A-3A					23	+2/-3 <sup>2</sup>		
CA_1A-5A					23	+2/-3		
CA_1A-7A					23	+2/-3 <sup>2</sup>		
CA_1A-8A					23	+2/-3 <sup>2</sup>		
CA_1A-11A					23	+2/-3 <sup>5</sup>		
CA_1A-18A					23	+2/-3 <sup>5</sup>		
CA_1A-19A					23	+2/-3		
CA_1A-20A					23	+2/-3		
CA_1A-21A					23	+2/-3		
CA_1A-26A					23	+2/-3 <sup>2</sup>		
CA_1A-28A					23	+2/-3		
CA_1A-42A					23	+2/-3		
CA_1A-42C					23	+2/-3		
CA_2A-4A					23	+2/-3 <sup>2</sup>		
CA_2A-5A					23	+2/-3 <sup>2</sup>		
CA_2A-7A					23	+2/-3 <sup>2</sup>		
CA_2A-12A					23	+2/-3 <sup>2</sup>		
CA_2A-13A					23	+2/-3 <sup>2</sup>		
CA_2A-14A					23	+2/-3 <sup>2</sup>		
CA_2A-30A					23	+2/-3 <sup>2</sup>		
CA_2A-46A					23	+2/-3		
CA_2A-48A					23	+2/-3		
CA_2A-49A					23	+2/-3		
CA_2A-66A					23	+2/-3 <sup>2</sup>		
CA_3A-5A					23	+2/-3 <sup>2</sup>		
CA_3A-7A					23	+2/-3 <sup>2</sup>		
CA_3A-8A					23	+2/-3 <sup>2</sup>		
CA_3A-11A					23	+2/-3 <sup>2</sup>		
CA_3A-18A					23	+2/-3 <sup>2</sup>		
CA_3A-19A					23	+2/-3 <sup>2</sup>		
CA_3A-20A					23	+2/-3 <sup>2</sup>		
CA_3A-21A					23	+2/-3 <sup>2</sup>		
CA_3A-26A					23	+2/-3 <sup>2</sup>		
CA_3A-28A					23	+2/-3 <sup>2</sup>		
CA_3A-40A					23	+2/-3 <sup>2</sup>		
CA_3A-41C					23	+2/-3 <sup>2</sup>		
CA_3A-42A					23	+2/-3 <sup>2</sup>		
CA_3A-42C					23	+2/-3 <sup>2</sup>		
CA_4A-5A					23	+2/-3		
CA_4A-7A					23	+2/-3 <sup>2</sup>		
CA_4A-12A					23	+2/-3 <sup>2</sup>		
CA_4A-13A					23	+2/-3		
CA_4A-17A					23	+2/-3		
CA_4A-28A					23	+2/-3		
CA_5A-7A					23	+2/-3 <sup>2</sup>		
CA_5A-12A					23	+2/-3 <sup>2</sup>		
CA_5A-17A					23	+2/-3		
CA_5A-30A					23	+2/-3 <sup>2</sup>		
CA_5A-40A					23	+2/-3 <sup>2</sup>		
CA_5A-66A					23	+2/-3 <sup>2</sup>		
CA_7A-8A					23	+2/-3 <sup>2</sup>		
CA_7A-20A					23	+2/-3 <sup>2</sup>		
CA_7A-26A					23	+2/-3 <sup>2</sup>		
CA_7A-28A					23	+2/-3 <sup>2</sup>		
CA_8A-39A					23	+2/-3 <sup>2</sup>		
CA_8A-41A					23	+2/-3 <sup>2</sup>		
CA_11A-18A					23	+2/-3		
CA_11A-26A					23	+2/-3		
CA_12A-30A					23	+2/-3		
CA_12A-66A					23	+2/-3		
CA_13A-66A					23	+2/-3		
CA_14A-30A					23	+2/-3		
CA_14A-66A					23	+2/-3 <sup>2</sup>		

CA_18A-28A				23	+2/-3		
CA_19A-21A				23	+2/-3		
CA_19A-42A				23	+2/-3		
CA_21A-28A				23	+2/-3		
CA_21A-42A				23	+2/-3		
CA_25A-26A				23	+2/-3		
CA_25A-41A				23	+2/-3		
CA_26A-46A				23	+2/-3		
CA_26A-48A				23	+2/-3		
CA_28A-41A				23	+2/-3		
CA_28A-42A				23	+2/-3		
CA_30A-66A				23	+2/-3		
CA_39A-41A				23	+2/-3 <sup>2</sup>		
CA_39A-41C				23	+2/-3 <sup>2</sup>		
CA_39C-41A				23	+2/-3 <sup>2</sup>		
CA_40A-42A				23	+2/-3 <sup>2</sup>		
CA_41A-42A				23	+2/-3 <sup>2</sup>		
CA_41A-42C				23	+2/-3 <sup>2</sup>		
CA_41C-42A				23	+2/-3 <sup>2</sup>		
CA_41C-42C				23	+2/-3 <sup>2</sup>		
NOTE 1: Void							
NOTE 2: <sup>2</sup> refers to the transmission bandwidths (Figure 5.6-1) confined within $F_{UL\_low}$ and $F_{UL\_low} + 4$ MHz or $F_{UL\_high} - 4$ MHz and $F_{UL\_high}$ , the maximum output power requirement is relaxed by reducing the lower tolerance limit by 1.5 dB							
NOTE 3: $P_{PowerClass}$ is the maximum UE power specified without taking into account the tolerance							
NOTE 4: For inter-band carrier aggregation the maximum power requirement should apply to the total transmitted power over all component carriers (per UE).							
NOTE 5: For a UE that supports both Band 18 and Band 26, the maximum output power requirement is relaxed by reducing the lower tolerance limit by 1.5 dB for transmission bandwidths confined within 815 MHz and 818 MHz.							

For uplink intra-band contiguous carrier aggregation the maximum output power is specified in Table 6.2.2A-1. For downlink intra-band contiguous carrier aggregation with a single uplink component carrier configured in the E-UTRA band, the maximum output power is specified in Table 6.2.2-1.

For a power class 2 capable UE operating with intra-band uplink contiguous CA bandwidth class C on Band 41, when an IE P-max as defined in TS 36.331 [7] of 23 dBm or lower is indicated in the cell or if the uplink/downlink configuration is 0 or 6, the requirements for power class 2 are not applicable, and the corresponding requirements for a power class 3 UE shall apply.

Table 6.2.2A-1: CA UE Power Class for intraband contiguous CA

E-UTRA CA Configuration	Class 1 (dBm)	Tolerance (dB)	Class 2 (dBm)	Tolerance (dB)	Class 3 (dBm)	Tolerance (dB)	Class 4 (dBm)	Tolerance (dB)
CA_1C					23	+2/-2		
CA_3C					23	+2/-2 <sup>2</sup>		
CA_5B					23	+2/-2 <sup>2</sup>		
CA_7C					23	+2/-2 <sup>2</sup>		
CA_8B					23	+2/-2 <sup>2</sup>		
CA_38C					23	+2/-2		
CA_39C					23	+2/-2		
CA_40C					23	+2/-2		
CA_40D					23	+2/-2		
CA_41C			26	+2/-2 <sup>2</sup>	23	+2/-2 <sup>2</sup>		
CA_41D					23	+2/-2 <sup>2</sup>		
CA_42C					23	+2/-3		
CA_48B					23	+2/-3		
CA_48C					23	+2/-3		
CA_66B					23	+2/-2		
CA_66C					23	+2/-2		

NOTE 1: Void  
NOTE 2: If all transmitted resource blocks (Figure 5.6A-1) over all component carriers are confined within  $F_{UL\_low}$  and  $F_{UL\_low} + 4$  MHz or/and  $F_{UL\_high} - 4$  MHz and  $F_{UL\_high}$ , the maximum output power requirement is relaxed by reducing the lower tolerance limit by 1.5 dB  
NOTE 3:  $P_{PowerClass}$  is the maximum UE power specified without taking into account the tolerance  
NOTE 4: For intra-band contiguous carrier aggregation the maximum power requirement should apply to the total transmitted power over all component carriers (per UE).

For intra-band non-contiguous carrier aggregation with one uplink carrier on the PCC, the requirements in subclause 6.2.2 apply. For intra-band non-contiguous carrier aggregation with two uplink carriers the maximum output power is specified in Table 6.2.2A-2.

Table 6.2.2A-2: UE Power Class for intraband non-contiguous CA

E-UTRA CA Configuration	Class 1 (dBm)	Tolerance (dB)	Class 2 (dBm)	Tolerance (dB)	Class 3 (dBm)	Tolerance (dB)	Class 4 (dBm)	Tolerance (dB)
CA_4A-4A					23	+2/-2		

NOTE 1: For transmission bandwidths (Figure 5.6-1) confined within  $F_{UL\_low}$  and  $F_{UL\_low} + 4$  MHz or  $F_{UL\_high} - 4$  MHz and  $F_{UL\_high}$ , the maximum output power requirement is relaxed by reducing the lower tolerance limit by 1.5 dB  
NOTE 2:  $P_{PowerClass}$  is the maximum UE power specified without taking into account the tolerance  
NOTE 3: For intra-band non-contiguous carrier aggregation the maximum power requirement should apply to the total transmitted power over all component carriers (per UE).

## 6.2.2B UE maximum output power for UL-MIMO

For UE with two transmit antenna connectors in closed-loop spatial multiplexing scheme, the maximum output power for any transmission bandwidth within the channel bandwidth is specified in Table 6.2.2B-1. The requirements shall be met with the UL-MIMO configurations specified in Table 6.2.2B-2. For UE supporting UL-MIMO, the maximum output power is measured as the sum of the maximum output power at each UE antenna connector. The period of measurement shall be at least as defined in Table 6.2.2B-0.

Table 6.2.2B-0: Measurement period for UE maximum output power for UL-MIMO

TTI pattern	Minimum measurement period
Subframe	1ms
Slot	7OS
Subslot	2OS, 3OS

**Table 6.2.2B-1: UE Power Class for UL-MIMO in closed loop spatial multiplexing scheme**

EUTRA band	Class 1 (dBm)	Tolerance (dB)	Class 2 (dBm)	Tolerance (dB)	Class 3 (dBm)	Tolerance (dB)	Class 4 (dBm)	Tolerance (dB)
1					23	+2/-3		
2					23	+2/-3 <sup>2</sup>		
3					23	+2/-3 <sup>2</sup>		
4					23	+2/-3		
5					23	+2/-3		
6					23	+2/-3		
7					23	+2/-3 <sup>2</sup>		
8					23	+2/-3 <sup>2</sup>		
9					23	+2/-3		
10					23	+2/-3		
11					23	+2/-3		
12					23	+2/-3 <sup>2</sup>		
13					23	+2/-3		
14					23	+2/-3		
...								
17					23	+2/-3		
18					23	+2/-3		
19					23	+2/-3		
20					23	+2/-3 <sup>2</sup>		
21					23	+2/-3		
22					23	+2/-4.5 <sup>2</sup>		
23					23	+2/-3		
24					23	+2/-3		
25					23	+2/-3 <sup>2</sup>		
26					23	+2/-3 <sup>2</sup>		
27					23	+2/-3		
28					23	+2/[-3]		
30					23	+2/-3		
31	31	+2/-3			23	+2/-3		
...								
33					23	+2/-3		
34					23	+2/-3		
35					23	+2/-3		
36					23	+2/-3		
37					23	+2/-3		
38			26	+2/-3	23	+2/-3		
39					23	+2/-3		
40			26	+2/-3	23	+2/-3		
41			26	+2/-3 <sup>2</sup>	23	+2/-3 <sup>2</sup>		
42			26	+2/-4	23	+2/-4		
43					23	+2/-4		
44					23	+2/[-3]		
45					23	+2/-3		
48					23	+2/-3		
50					23	+2/-3		
51					23	+2/-3		
52					23	+2/-3		
53					23	+2/-3		
...								
65					23	+2/-3		
66					23	+2/-3		
68					23	+2/-3		
...								
70					23	+2/-3		
71					23	+2/-3		
72	31	+2/-3			23	+2/-3		
73					23	+2/-3		
74					23	+2/-3		

NOTE 1: Void  
 NOTE 2: <sup>2</sup> refers to the transmission bandwidths (Figure 5.6-1) confined within  $F_{UL\_low}$  and  $F_{UL\_low} + 4$  MHz or  $F_{UL\_high} - 4$  MHz and  $F_{UL\_high}$ , the maximum output power requirement is relaxed by reducing the lower tolerance limit by 1.5 dB  
 NOTE 3: For the UE which supports both Band 11 and Band 21 operating frequencies, the tolerance is FFS.  
 NOTE 4:  $P_{PowerClass}$  is the maximum UE power specified without taking into account the tolerance  
 NOTE 5: Void.

The default power class for an operating band is Power Class 3 unless otherwise stated.

For a power class 2 capable UE operating on Band 41, when an IE  $P_{-max}$  as defined in TS 36.331 [7] of 23 dBm or lower is indicated in the cell or if the uplink/downlink configuration is 0 or 6, the requirements for power class 2 are not applicable and the corresponding requirements for a power class 3 UE shall apply.

For each supported frequency band other than Band 41, the UE shall:

- if the UE supports a different power class than the UE default power class for the band and the supported power class enables the higher maximum output power than that of the default power class:
  - if the band is a TDD band whose frame configuration is 0 or 6; or
  - if the IE  $P_{-Max}$  as defined in TS 36.331 [7] is not provided; or
  - if the IE  $P_{-Max}$  as defined in TS 36.331 [7] is provided and set to the maximum output power of the default power class or lower;
    - meet all requirements for the default power class of the operating band in which the UE is operating and set its configured transmitted power as specified in sub-clause 6.2.5;
  - else (i.e the IE  $P_{-Max}$  as defined in TS 36.331 [7] is provided and set to the higher value than the maximum output power of the default power class):
    - meet all requirements for the supported power class and set its configured transmitted power as specified in sub-clause 6.2.5;

**Table 6.2.2B-2: UL-MIMO configuration in closed-loop spatial multiplexing scheme**

Transmission mode	DCI format	Codebook Index
Mode 2	DCI format 4	Codebook index 0

If UE is configured for transmission on single-antenna port, the requirements in subclause 6.2.2 apply.

## 6.2.2C Void

<reserved for future use>

## 6.2.2D UE maximum output power for ProSe

When UE is configured for simultaneous E-UTRA ProSe sidelink and E-UTRA uplink transmissions for inter-band E-UTRA ProSe / E-UTRA bands specified in Table 5.5D-2, the UE maximum output power shall be as specified in Table 6.2.2A-0 in subclause 6.2.2A for the corresponding inter-band aggregation with uplink assigned to two bands.

If UE is configured to operate on single E-UTRA ProSe sidelink band or E-UTRA uplink band specified in Table 5.5D-1, the requirements in subclause 6.2.2 apply.

## 6.2.2E UE maximum output power for Category M1 and M2 UE

The following UE Power Classes define the maximum output power for any transmission bandwidth within the channel bandwidth for non CA configuration and UL-MIMO unless otherwise stated. The period of measurement shall be at least one sub frame (1ms).



Table 6.2.2E-1: UE Power Class

EUTRA band	Class 2 (dBm)	Tolerance (dB)	Class 3 (dBm)	Tolerance (dB)	Class 5 (dBm)	Tolerance (dB)	Class 6 (dBm)	Tolerance (dB)
1			23	$\pm 2$	20	$\pm 2$	14	$\pm 2.5$
2			23	$\pm 2^2$	20	$\pm 2^2$	14	$\pm 2.5$
3			23	$\pm 2^2$	20	$\pm 2^2$	14	$\pm 2.5$
4			23	$\pm 2$	20	$\pm 2$	14	$\pm 2.5$
5			23	$\pm 2$	20	$\pm 2$	14	$\pm 2.5$
7			23	$\pm 2^2$	20	$\pm 2^2$	14	$\pm 2.5$
8			23	$\pm 2^2$	20	$\pm 2^2$	14	$\pm 2.5$
11			23	$\pm 2$	20	$\pm 2$	14	$\pm 2.5$
12			23	$\pm 2^2$	20	$\pm 2^2$	14	$\pm 2.5$
13			23	$\pm 2$	20	$\pm 2$	14	$\pm 2.5$
14			23	$\pm 2$	20	$\pm 2$	14	$\pm 2.5$
18			23	$\pm 2^5$	20	$\pm 2^5$	14	$\pm 2.5$
19			23	$\pm 2$	20	$\pm 2$	14	$\pm 2.5$
20			23	$\pm 2^2$	20	$\pm 2^2$	14	$\pm 2.5$
21			23	$\pm 2$	20	$\pm 2$	14	$\pm 2.5$
25			23	$\pm 2^2$	20	$\pm 2$	14	$\pm 2.5$
26			23	$\pm 2^2$	20	$\pm 2^2$	14	$\pm 2.5$
27			23	$\pm 2$	20	$\pm 2$	14	$\pm 2.5$
28			23	$+2/-2.5$	20	$+2/-2.5$	14	$\pm 2.5$
31	26 <sup>7</sup>	$\pm 2$	23	$\pm 2$	20	$\pm 2$	14	$\pm 2.5$
...								
39			23	$\pm 2$	20	$\pm 2$	14	$\pm 2.5$
40			23	$\pm 2^2$	20	$\pm 2$	14	$\pm 2.5$
41			23	$\pm 2^2$	20	$\pm 2^2$	14	$\pm 2.5$
42			23	$+2/-3$	20	$+2/-3$	14	$\pm 2.5$
43			23	$+2/-3$	20	$+2/-3$	14	$\pm 2.5$
...								
71			23	$\pm 2$	20	$\pm 2$	14	$\pm 2.5$
72	26 <sup>7</sup>	$\pm 2$	23	$\pm 2$	20	$\pm 2$	14	$\pm 2.5$
73			23	$\pm 2$	20	$\pm 2$	14	$\pm 2.5$
74			23	$\pm 2$	20	$\pm 2$	14	$\pm 2.5$
85			23	$\pm 2^2$	20	$\pm 2^2$	14	$\pm 2.5$
87			23	$\pm 2$	20	$\pm 2$	14	$\pm 2.5$
88			23	$\pm 2$	20	$\pm 2$	14	$\pm 2.5$
NOTE 1: Void								
NOTE 2: <sup>2</sup> refers to the transmission bandwidths (Figure 5.6-1) confined within $F_{UL\_low}$ and $F_{UL\_low} + 4$ MHz or $F_{UL\_high} - 4$ MHz and $F_{UL\_high}$ , the maximum output power requirement is relaxed by reducing the lower tolerance limit by 1.5 dB								
NOTE 3: For the UE which supports both Band 11 and Band 21 operating frequencies, the tolerance is FFS.								
NOTE 4: $P_{PowerClass}$ is the maximum UE power specified without taking into account the tolerance								
NOTE 5: For a UE that supports both Band 18 and Band 26, the maximum output power requirement is relaxed by reducing the lower tolerance limit by 1.5 dB for transmission bandwidths confined within 815 MHz and 818 MHz.								
NOTE 6: Void								
NOTE 7: Applicable for category M1 and M2 HD-FDD UE								

## 6.2.2F UE maximum output power for category NB1 and NB2

Category NB1 and NB2 UE Power Classes are specified in Table 6.2.2F-1 and define the maximum output power for any transmission bandwidth within the category NB1 and NB2 channel bandwidth. For 3.75 kHz sub-carrier spacing the maximum output power is defined as mean power of measurement which period is atleast one slot (2ms) excluding the 2304Ts gap when UE is not transmitting. For 15kHz sub-carrier spacing the maximum output power is defined as mean power of measurement which period is atleast one sub-frame (1ms).

Table 6.2.2F-1: UE Power Class

EUTRA band	Class 3 (dBm)	Tolerance (dB)	Class 5 (dBm)	Tolerance (dB)	Class 6 (dBm)	Tolerance (dB)
1	23	±2	20	±2	14	±2.5
2	23	±2	20	±2	14	±2.5
3	23	±2	20	±2	14	±2.5
4	23	±2	20	±2	14	±2.5
5	23	±2	20	±2	14	±2.5
7	23	±2	20	±2	14	±2.5
8	23	±2	20	±2	14	±2.5
11	23	±2	20	±2	14	±2.5
12	23	±2	20	±2	14	±2.5
13	23	±2	20	±2	14	±2.5
14	23	±2	20	±2	14	±2.5
17	23	±2	20	±2	14	±2.5
18	23	±2	20	±2	14	±2.5
19	23	±2	20	±2	14	±2.5
20	23	±2	20	±2	14	±2.5
21	23	±2	20	±2	14	±2.5
25	23	±2	20	±2	14	±2.5
26	23	±2	20	±2	14	±2.5
28	23	±2	20	±2	14	±2.5
31	23	±2	20	±2	14	±2.5
41	23	±2	20	±2	14	±2.5
42	23	±2	20	±2	14	±2.5
43	23	±2	20	±2	14	±2.5
65	23	±2	20	±2	14	±2.5
66	23	±2	20	±2	14	±2.5
70	23	±2	20	±2	14	±2.5
71	23	±2	20	±2	14	±2.5
72	23	±2	20	±2	14	±2.5
73	23	±2	20	±2	14	±2.5
74	23	±2	20	±2	14	±2.5
85	23	±2	20	±2	14	±2.5
87	23	±2	20	±2	14	±2.5
88	23	±2	20	±2	14	±2.5

## 6.2.2G UE maximum output power for V2X Communication

When UE is configured for E-UTRA V2X sidelink transmissions non-concurrent with E-UTRA uplink transmissions for E-UTRA V2X operating bands specified in Table 5.5G-1, the allowed V2X UE maximum output power shall be as applied in Table 6.2.2-1 in subclause 6.2.2.

For V2X UE is configured for simultaneous E-UTRA V2X sidelink and E-UTRA uplink transmissions for inter-band E-UTRA V2X / E-UTRA bands specified in Table 5.5G-2, the UE maximum output power shall be as specified in Table 6.2.2G-1 in subclause 6.2.2G for the corresponding inter-band con-current operation with uplink assigned to two bands.

Table 6.2.2G-1: Inter-band con-current V2X UE Power Class (two bands)

V2X con-current band Configuration	Class 1 (dBm)	Tolerance (dB)	Class 2 (dBm)	Tolerance (dB)	Class 3 (dBm)	Tolerance (dB)	Class 4 (dBm)	Tolerance (dB)
V2X_3A-47A					23	+2/-3 <sup>4</sup>		
V2X_5A-47A					23	+2/-3 <sup>4</sup>		
V2X_7A-47A					23	+2/-3 <sup>4</sup>		
V2X_8A-47A					23	+2/-3 <sup>4</sup>		
V2X_20A-47A					23	+2/-3 <sup>4</sup>		
V2X_28A-47A					23	+2/-3 <sup>4</sup>		
V2X_34A-47A					23	+2/-3 <sup>4</sup>		
V2X_39A-47A					23	+2/-3 <sup>4</sup>		
V2X_41A-47A					23	+2/-3 <sup>4</sup>		
V2X_71A-47A					23	+2/-3 <sup>4</sup>		

NOTE 1: The con-current band combinations is used for V2X Service.  
NOTE 2:  $P_{PowerClass}$  is the maximum UE power specified without taking into account the tolerance  
NOTE 3: For inter-band con-current aggregation the maximum power requirement apply to the total transmitted power over all component carriers (per UE).  
NOTE 4: <sup>4</sup> refers to the transmission bandwidths (Figure 5.6-1) confined within  $F_{UL\_low}$  and  $F_{UL\_low} + 4$  MHz or  $F_{UL\_high} - 4$  MHz and  $F_{UL\_high}$ , the maximum output power requirement is relaxed by reducing the lower tolerance limit by 1.5 dB

For intra-band contiguous multi-carrier operation, the maximum output power is defined in Table 6.2.2G-2.

Table 6.2.2G-2: V2X UE Power Class for intra-band contiguous multi-carrier operation

V2X intra-band multi-carrier configuration	Class 1 (dBm)	Tolerance (dB)	Class 2 (dBm)	Tolerance (dB)	Class 3 (dBm)	Tolerance (dB)	Class 4 (dBm)	Tolerance (dB)
V2X_47B					23	±2		
V2X_47C					23	±2		

NOTE 1:  $P_{PowerClass}$  is the maximum UE power specified without taking into account the tolerance  
NOTE 2: For intra-band multi-carrier operation, the maximum power requirement should apply to the total transmitted power over all component carriers (per UE).

When a UE is configured for E-UTRA V2X sidelink transmissions in Band 47, the UE shall meet the following additional requirements for transmission within the frequency ranges 5855-5925 MHz:

- The maximum mean power spectral density shall be restricted to 23 dBm/MHz EIRP when the network signaling value NS\_33 or NS\_34 is indicated.

where the network signaling values are specified in clause 6.2.4G.

NOTE: The PSD limit in EIRP shall be converted to conducted requirement depend on the supported post antenna connector gain  $G_{post\_connector}$  declared by the UE following the principle described in annex I.

For V2X UE supporting Transmit Diversity, if the UE transmits on two connectors at the same time, the maximum output power for any transmission bandwidth within the channel bandwidth is specified in Table 6.2.2G-3. The maximum output power is measured as the sum of the maximum output power at each UE antenna connector. The period of measurement shall be at least one sub frame (1ms).

Table 6.2.2G-3: V2X UE Power Class for Transmit Diversity scheme

E-UTRA band	Class 1 (dBm)	Tolerance (dB)	Class 2 (dBm)	Tolerance (dB)	Class 3 (dBm)	Tolerance (dB)	Class 4 (dBm)	Tolerance (dB)
47			26	+2/-3	23	+2/-3		

If the UE transmits on one antenna connector at a time, the requirements in Table 6.2.2-1 shall apply to the active antenna connector.

## 6.2.3 UE maximum output power for modulation / channel bandwidth

For UE Power Class 1, 2 and 3, the allowed Maximum Power Reduction (MPR) for the maximum output power in Table 6.2.2-1 due to higher order modulation and transmit bandwidth configuration (resource blocks) is specified in Table 6.2.3-1.

**Table 6.2.3-1: Maximum Power Reduction (MPR) for Power Class 1, 2 and 3**

Modulation	Channel bandwidth / Transmission bandwidth ( $N_{RB}$ )						MPR (dB)
	1.4 MHz	3.0 MHz	5 MHz	10 MHz	15 MHz	20 MHz	
QPSK	> 5	> 4	> 8	> 12	> 16	> 18	≤ 1
16 QAM	≤ 5	≤ 4	≤ 8	≤ 12	≤ 16	≤ 18	≤ 1
16 QAM	> 5	> 4	> 8	> 12	> 16	> 18	≤ 2
64 QAM	≤ 5	≤ 4	≤ 8	≤ 12	≤ 16	≤ 18	≤ 2
64 QAM	> 5	> 4	> 8	> 12	> 16	> 18	≤ 3
256 QAM	≥ 1						≤ 5

For PRACH, PUCCH and SRS transmissions, the allowed MPR is according to that specified for PUSCH QPSK modulation for the corresponding transmission bandwidth.

For each TTI pattern, the MPR shall be evaluated per  $T_{eval}$  period as specified in table 6.2.3-2 and given by the maximum value taken over the transmission(s) within that period; the maximum MPR over  $T_{REF}$  is then applied for  $T_{REF}$ .

**Table 6.2.3-2: MPR evaluation period**

TTI pattern	$T_{REF}$	$T_{eval}$
Subframe	1 subframe	1 slot
Slot	7 OS	$\text{Min}(T_{no\_hopping}, 7\text{OS})$
Sublot	2 OS, 3OS	$\text{Min}(T_{no\_hopping}, 2\text{OS}/3\text{OS})$

For UE Power Class 1 and 3 transmissions with non-contiguous resource allocation in single component carrier, the allowed Maximum Power Reduction (MPR) for the maximum output power in table 6.2.2-1, is specified as follows

$$\text{MPR} = \text{CEIL}\{M_A, 0.5\}$$

Where  $M_A$  is defined as follows for QPSK, 16 QAM and 64 QAM

$$M_A = \begin{cases} 8.00 - 10.12A & ; 0.00 < A \leq 0.33 \\ 5.67 - 3.07A & ; 0.33 < A \leq 0.77 \\ 3.31 & ; 0.77 < A \leq 1.00 \end{cases}$$

Where  $M_A$  is defined as follows for 256 QAM

$$M_A = \begin{cases} 8.00 - 10.12A & ; 0.00 < A \leq 0.25 \\ 5.50 & ; 0.25 < A < 1.00 \end{cases}$$

Where

$$A = N_{RB\_alloc} / N_{RB}$$

$\text{CEIL}\{M_A, 0.5\}$  means rounding upwards to closest 0.5dB, i.e.  $\text{MPR} \in \{3.0, 3.5, 4.0, 4.5, 5.0, 5.5, 6.0, 6.5, 7.0, 7.5, 8.0\}$

The allowed MPR for transmission on an Scell in Band 46 or Band 49 within a component carrier of a nominal channel bandwidth of 10 MHz or 20 MHz is in accordance with 6.2.3-1 for  $RIV = '11111'$  (10 MHz) and  $L = 10$  (20 MHz) with  $L$  defined in Clause 8.1.4 of [6]. For all other possible values of the  $RIV$  defined in Clause 8.1.4 of [6] the allowed MPR is 2.5 dB for QPSK modulation, 3 dB for 16QAM modulation and 4 dB for 64QAM modulation (256QAM is FFS).

For a power class 2 capable UE operating on Band 41, when an IE *P-max* as defined in [7] of 23 dBm or lower is indicated in the cell or if the uplink/downlink configuration is 0 or 6, the requirements for power class 2 are not applicable, and the corresponding requirements for a power class 3 UE shall apply.

For each supported frequency band other than Band 41, the UE shall:

- if the UE supports a different power class than the default UE power class for the band and the supported power class enables the higher maximum output power than that of the default power class:
  - if the band is a TDD band whose frame configuration is 0 or 6; or
  - if the IE *P-Max* as defined in TS 36.331 [7] is not provided; or
  - if the IE *P-Max* as defined in TS 36.331 [7] is provided and set to the maximum output power of the default power class or lower;
    - meet all requirements for the default power class of the operating band in which the UE is operating and set its configured transmitted power as specified in sub-clause 6.2.5;
  - else (i.e the IE *P-Max* as defined in TS 36.331 [7] is provided and set to the higher value than the maximum output power of the default power class):
    - meet all requirements for the supported power class and set its configured transmitted power class as specified in sub-clause 6.2.5.

For UE Power Class 2 transmissions with non-contiguous resource allocation in single component carrier, the allowed Maximum Power Reduction (MPR) for the maximum output power is not specified in this version of the specification.

For the UE maximum output power modified by MPR, the power limits specified in subclause 6.2.5 apply.

### 6.2.3A UE Maximum Output power for modulation / channel bandwidth for CA

For inter-band carrier aggregation with one uplink component carrier assigned to one E-UTRA band, the requirements in subclause 6.2.3 apply. For inter-band carrier aggregation with two uplink contiguous component carrier assigned to one E-UTRA band specified in this clause for intra-band contiguous carrier aggregation apply for that band.

For inter-band carrier aggregation with one component carrier per operating band and the uplink active in two E-UTRA bands, the requirements in subclause 6.2.3 apply for each uplink component carrier.

For intra-band contiguous carrier aggregation the allowed Maximum Power Reduction (MPR) for the maximum output power in Table 6.2.2A-1 due to higher order modulation and contiguously aggregated transmit bandwidth configuration (resource blocks) is specified in Table 6.2.3A-1 for UE power class 3 CA bandwidth classes B and C, in Table 6.2.3A-1a for UE power class 2 CA bandwidth class C, and Table 6.2.3A-2 for UE power class 3 CA bandwidth class D. In case the modulation format is different on different component carriers then the MPR is determined by the rules applied to higher order of those modulations.

**Table 6.2.3A-1: Maximum Power Reduction (MPR) for Power Class 3**

Modulation	CA bandwidth Class B and C / Smallest Component Carrier Transmission Bandwidth Configuration				MPR (dB)
	25 RB	50 RB	75 RB	100 RB	

QPSK	> 8 and ≤ 25	> 12 and ≤ 50	> 16 and ≤ 75	> 18 and ≤ 100	≤ 1
QPSK	> 25	> 50	> 75	> 100	≤ 2
16 QAM	≤ 8	≤ 12	≤ 16	≤ 18	≤ 1
16 QAM	> 8 and ≤ 25	> 12 and ≤ 50	> 16 and ≤ 75	> 18 and ≤ 100	≤ 2
16 QAM	> 25	> 50	> 75	> 100	≤ 3
64 QAM	≤ 8 and allocation wholly contained within a single CC	≤ 12 and allocation wholly contained within a single CC	≤ 16 and allocation wholly contained within a single CC	≤ 18 and allocation wholly contained within a single CC	≤ 2
64 QAM	> 8 or allocation extends across two CC's	> 12 or allocation extends across two CC's	> 16 or allocation extends across two CC's	> 18 or allocation extends across two CC's	≤ 3
256 QAM	≥ 1				≤ 5

Table 6.2.3A-1a: Maximum Power Reduction (MPR) for Power Class 2

Modulation	CA bandwidth Class C / Smallest Component Carrier Transmission Bandwidth Configuration				MPR (dB)
	25 RB	50 RB	75 RB	100 RB	
QPSK	> 6 and ≤ 25	> 6 and ≤ 50	> 6 and ≤ 75	> 6 and ≤ 100	≤ 1
QPSK	> 25	> 50	> 75	> 100	≤ 2
16 QAM	≤ 6	≤ 8	≤ 16	≤ 18	≤ 1.5
16 QAM	> 6 and ≤ 25	> 8 and ≤ 50	> 16 and ≤ 75	> 18 and ≤ 100	≤ 2
16 QAM	> 25	> 50	> 75	> 100	≤ 3
64 QAM	≤ 8 and allocation wholly contained within a single CC	≤ 12 and allocation wholly contained within a single CC	≤ 16 and allocation wholly contained within a single CC	≤ 18 and allocation wholly contained within a single CC	≤ 2
64 QAM	> 8 or allocation extends across two CC's	> 12 or allocation extends across two CC's	> 16 or allocation extends across two CC's	> 18 or allocation extends across two CC's	≤ 3
256 QAM	FFS				FFS

Table 6.2.3A-2: Maximum Power Reduction (MPR) for Class 3

Modulation	CA bandwidth Class D					MPR (dB)
	50 RB + 75 RB + 100RB	50 RB + 100 RB + 100 RB	75 RB + 75 RB + 100 RB	75 RB + 100 RB + 100 RB	100 RB + 100 RB + 100 RB	
QPSK	> 12 and ≤ 50	> 12 and ≤ 50	> 16 and ≤ 75	> 16 and ≤ 75	> 18 and ≤ 100	≤ 1
QPSK	> 50 and ≤ 125	> 50 and ≤ 150	> 75 and ≤ 150	> 75 and ≤ 175	> 100 and ≤ 200	≤ 2
QPSK	> 125	> 150	> 150	> 175	> 200	≤ 3
16 QAM	≤ 12	≤ 12	≤ 16	≤ 16	≤ 18	≤ 1
16 QAM	> 12 and ≤ 50	> 12 and ≤ 50	> 16 and ≤ 75	> 16 and ≤ 75	> 18 and ≤ 100	≤ 2
16 QAM	> 50 and ≤ 125	> 50 and ≤ 150	> 75 and ≤ 150	> 75 and ≤ 175	> 100 and ≤ 200	≤ 3
16 QAM	> 125	> 150	> 150	> 175	> 200	≤ 3.5
64 QAM	≤ 12 allocation wholly contained within a single CC	≤ 12 and allocation wholly contained within a single CC	≤ 16 and allocation wholly contained within a single CC	≤ 16 and allocation wholly contained within a single CC	≤ 18 and allocation wholly contained within a single CC	≤ 2
64 QAM	> 12 allocation wholly contained within a single CC or allocation extends across two CC's	> 12 allocation wholly contained within a single CC or allocation extends across two CC's	> 16 allocation wholly contained within a single CC or allocation extends across two CC's	> 16 allocation wholly contained within a single CC or allocation extends across two CC's	> 18 allocation wholly contained within a single CC or allocation extends across two CC's	≤ 3
64 QAM	allocation extends across three CC's	allocation extends across three CC's	allocation extends across three CC's	allocation extends across three CC's	allocation extends across three CC's	≤ 4.0
256 QAM	≥ 1					≤ 5.5

For PUCCH and SRS transmissions, the allowed MPR is according to that specified for PUSCH QPSK modulation for the corresponding transmission bandwidth.

For UE power class 3 intra-band contiguous carrier aggregation bandwidth class C with non-contiguous resource allocation, the allowed Maximum Power Reduction (MPR) for the maximum output power in Table 6.2.2A-1 is specified as follows

$$\text{MPR} = \text{CEIL} \{ \min(M_A, M_{\text{IMS}}), 0.5 \}$$

Where  $M_A$  is defined as follows for QPSK, 16 QAM and 64 QAM

$$\begin{aligned} M_A &= 8.2 && ; 0 \leq A < 0.025 \\ &9.2 - 40A && ; 0.025 \leq A < 0.05 \\ &8 - 16A && ; 0.05 \leq A < 0.25 \\ &4.83 - 3.33A && ; 0.25 \leq A \leq 0.4, \\ &3.83 - 0.83A && ; 0.4 \leq A \leq 1, \end{aligned}$$

Where  $M_A$  is defined as follows for 256 QAM

$$\begin{aligned} M_A &= 8.2 && ; 0 \leq A < 0.025 \\ &9.2 - 40A && ; 0.025 \leq A < 0.05 \end{aligned}$$

$$8 - 16A \quad ; 0.05 \leq A < 0.16$$

$$5.5 \quad ; 0.16 \leq A < 1$$

and  $M_{IM5}$  is defined as follows

$$M_{IM5} = 4.5 \quad ; \Delta_{IM5} < 1.5 * BW_{Channel\_CA}$$

$$6.0 \quad ; 1.5 * BW_{Channel\_CA} \leq \Delta_{IM5} < BW_{Channel\_CA}/2 + F_{OOB}$$

$$M_A \quad ; \Delta_{IM5} \geq BW_{Channel\_CA}/2 + F_{OOB}$$

For UE power class 2 intra-band contiguous carrier aggregation bandwidth class C with non-contiguous resource allocation, the allowed Maximum Power Reduction (MPR) for the maximum output power in Table 6.2.2A-1 is specified as follows

$$MPR = CEIL \{ \min(M_A, M_{IM5}), 0.5 \}$$

Where  $M_A$  is defined as follows for QPSK, 16 QAM and 64 QAM

$$M_A = 8.2 \quad ; 0 \leq A < 0.04$$

$$9.2 - 40A \quad ; 0.04 \leq A < 0.075$$

$$8 - 16A \quad ; 0.075 \leq A < 0.25$$

$$4.83 - 3.33A \quad ; 0.25 \leq A \leq 0.4,$$

$$3.83 - 0.83A \quad ; 0.4 \leq A \leq 1,$$

Where  $M_A$  is defined FFS for 256 QAM

and  $M_{IM5}$  is defined as follows

$$M_{IM5} = 5.0 \quad ; \Delta_{IM5} < 1.5 * BW_{Channel\_CA}$$

$$6.0 \quad ; 1.5 * BW_{Channel\_CA} \leq \Delta_{IM5} < BW_{Channel\_CA}/2 + F_{OOB}$$

$$M_A \quad ; \Delta_{IM5} \geq BW_{Channel\_CA}/2 + F_{OOB}$$

For UE power class 3 intra-band contiguous carrier aggregation bandwidth class B with non-contiguous resource allocation, the allowed Maximum Power Reduction (MPR) for the maximum output power in Table 6.2.2A-1 is specified as follows

$$MPR = CEIL \{ M_A, 0.5 \}$$

Where  $M_A$  is defined as follows for QPSK, 16 QAM and 64 QAM

$$M_A = 10.5 - 17.5A \quad ; 0 \leq A < 0.2$$

$$8.5 - 7.5A \quad ; 0.2 \leq A < 0.6$$

$$5.5 - 2.5A \quad ; 0.6 \leq A \leq 1$$

Where  $M_A$  is defined as follows for 256 QAM

$$M_A = 10.5 - 17.5A \quad ; 0 \leq A < 0.2$$

$$8.5 - 7.5A \quad ; 0.2 \leq A < 0.4$$

$$5.5 \quad ; 0.4 \leq A \leq 1$$

Where

$$A = N_{RB\_alloc} / N_{RB\_agg}$$

$$\Delta_{IM5} = \max( |F_{C\_agg} - (3 * F_{agg\_alloc\_low} - 2 * F_{agg\_alloc\_high})|, |F_{C\_agg} - (3 * F_{agg\_alloc\_high} - 2 * F_{agg\_alloc\_low})| )$$



$$F_{C\_agg} = (F_{edge\_high} + F_{edge\_low})/2$$

For UE power class 3 intra-band contiguous carrier aggregation bandwidth class D with non-contiguous resource allocation, the allowed Maximum Power Reduction (MPR) for the maximum output power in Table 6.2.3A-2 is specified as follows

$$MPR = \text{CEIL} \{ \min(M_A, M_{IM5}), 0.5 \}$$

Where  $M_A$  is defined as follows for QPSK, 16 QAM and 64 QAM

$$\begin{aligned} M_A = & 8.2 && ; 0 \leq A < 0.025 \\ & 9.2 - 40A && ; 0.025 \leq A < 0.05 \\ & 8 - 16A && ; 0.05 \leq A < 0.25 \\ & 4.0 && ; 0.25 \leq A < 1 \end{aligned}$$

Where  $M_A$  is defined as follows for 256 QAM

$$\begin{aligned} M_A = & 8.2 && ; 0 \leq A < 0.025 \\ & 9.2 - 40A && ; 0.025 \leq A < 0.05 \\ & 8 - 16A && ; 0.05 \leq A < 0.16 \\ & 5.5 && ; 0.16 \leq A < 1 \end{aligned}$$

and  $M_{IM5}$  is defined as follows

$$\begin{aligned} M_{IM5} = & 4.5 && ; \Delta_{IM5} < 1.5 * BW_{Channel\_CA} \\ & 6.0 && ; 1.5 * BW_{Channel\_CA} \leq \Delta_{IM5} < BW_{Channel\_CA}/2 + F_{OOB} \\ M_A & && ; \Delta_{IM5} \geq BW_{Channel\_CA}/2 + F_{OOB} \end{aligned}$$

$\text{CEIL}\{M_A, 0.5\}$  means rounding upwards to closest 0.5dB, i.e.  $MPR \in [3.0, 3.5, 4.0, 4.5, 5.0, 5.5, 6.0, 6.5, 7.0, 7.5, 8.0, 8.5]$ .

For intra-band non-contiguous carrier aggregation with one uplink carrier, the requirements in subclause 6.2.3 apply.

For intra-band non-contiguous carrier aggregation with two uplink carriers MPR is specified for E-UTRA CA configurations with a maximum possible  $W_{GAP} \leq 35$  MHz; the allowed MPR is

$$MPR = \text{CEIL} \{ M_N, 0.5 \}$$

where  $M_N$  is defined as follows

$$\begin{aligned} M_N = & -0.125 N + 18.25 && ; 2 \leq N \leq 50 \\ & -0.0333 N + 13.67 && ; 50 < N \leq 200 \end{aligned}$$

where  $N = N_{RB\_alloc}$  is the number of allocated resource blocks. Clause 6.2.3 does not apply in addition. E-UTRA CA configurations with a maximum possible  $W_{gap} > 35$  MHz and their corresponding MPR are intended to form part of a later release.

For intra-band carrier aggregation, the MPR is evaluated per  $T_{eval}$  period specified in table 6.2.3A-3 and given by the maximum value taken over the transmission(s) on all component carriers within that period; the maximum MPR over  $T_{REF}$  is then applied for  $T_{REF}$ .

**Table 6.2.3A-3: MPR evaluation period for CA**

<b>TTI pattern</b>	<b>T<sub>REF</sub></b>	<b>T<sub>eval</sub></b>
Subframe	1 subframe	1 slot
Slot	7 OS	Min( $T_{no\_hopping}$ , 7OS)
Sublot	2 OS, 3OS	Min( $T_{no\_hopping}$ , 2OS/3OS)

For combinations of intra-band and inter-band carrier aggregation with three uplink component carriers (up to two contiguously aggregated carriers per band), the requirements specified in subclause 6.2.3 apply for the E-UTRA band supporting one component carrier, and for the E-UTRA band supporting two contiguous component carriers the requirements specified in subclause 6.2.3A apply.

For the UE maximum output power modified by MPR, the power limits specified in subclause 6.2.5A apply.

### 6.2.3B UE maximum output power for modulation / channel bandwidth for UL-MIMO

For UE with two transmit antenna connectors in closed-loop spatial multiplexing scheme, the allowed Maximum Power Reduction (MPR) for the maximum output power in Table 6.2.2B-1 is specified in Table 6.2.3-1. The requirements shall be met with UL-MIMO configurations defined in Table 6.2.2B-2. For UE supporting UL-MIMO, the maximum output power is measured as the sum of the maximum output power at each UE antenna connector.

For the UE maximum output power modified by MPR, the power limits specified in subclause 6.2.5B apply.

If UE is configured for transmission on single-antenna port, the requirements in subclause 6.2.3 apply.

### 6.2.3D UE maximum output power for modulation / channel bandwidth for ProSe

When UE is configured for E-UTRA ProSe sidelink transmissions non-concurrent with E-UTRA uplink transmissions for E-UTRA ProSe operating bands specified in Table 5.5D-1, this subclause specifies the allowed Maximum Power Reduction (MPR) power for ProSe physical channels and signals due to higher order modulation and transmit bandwidth configuration (resource blocks).

The allowed MPR for the maximum output power for ProSe physical channels PSDCH, PSCCH, PSSCH, and PSBCH shall be as specified in subclause 6.2.3 for PUSCH for the corresponding modulation and transmission bandwidth.

The allowed MPR for the maximum output power for ProSe physical signal PSSS shall be as specified in subclause 6.2.3 for PUSCH QPSK modulation for the corresponding transmission bandwidth.

The allowed MPR for the maximum output power for ProSe physical signal SSSS is specified in Table 6.2.3D-1.

For a power class 2 capable UE operating on Band 41, the corresponding requirements for a power class 3 UE apply when an IE  $P_{max}$  as defined in [7] of 23 dBm or lower is indicated in the cell or if the uplink/downlink configuration is 0 or 6.

For each supported frequency band other than Band 41, the UE shall:

- if the UE supports a different power class than the default UE power class for the band and the supported power class enables the higher maximum output power than that of the default power class:
- if the band is a TDD band whose frame configuration is 0 or 6; or
- if the IE  $P_{Max}$  as defined in TS 36.331 [7] is not provided; or
- if the IE  $P_{Max}$  as defined in TS 36.331 [7] is provided and set to the maximum output power of the default power class or lower;

- meet all requirements for the default power class of the operating band in which the UE is operating and set its configured transmitted power as specified in sub-clause 6.2.5;
- else (i.e the IE *P-Max* as defined in TS 36.331 [7] is provided and set to the higher value than the maximum output power of the default power class):
  - meet all requirements for the supported power class and set its configured transmitted power class as specified in sub-clause 6.2.5.

**Table 6.2.3D-1: Maximum Power Reduction (MPR) for SSSS for Power Class 1, 2 and 3**

Channel bandwidth	MPR for SSSS (dB)
1.4 MHz	
3.0 MHz	
5.0 MHz	≤ 4
10 MHz	≤ 4
15 MHz	≤ 4
20 MHz	≤ 4

When UE is configured for simultaneous E-UTRA ProSe sidelink and E-UTRA uplink transmissions for inter-band E-UTRA ProSe / E-UTRA bands specified in Table 5.5D-2, the requirements in subclause 6.2.3D apply for ProSe transmission and the requirements in subclause 6.2.3 apply for uplink transmission.

### 6.2.3E UE maximum output power for modulation / channel bandwidth for category M1 and M2

For category M1 UE Power Class 3, 5 and 6, the allowed Maximum Power Reduction (MPR) for the maximum output power specified in Table 6.2.2E-1 due to higher order modulation and transmit bandwidth configuration (resource blocks) is specified in Tables 6.2.3E-1, 6.2.3E-2 and 6.2.3E-5 respectively.

For category M2 UE Power Class 3, 5 and 6, the allowed Maximum Power Reduction (MPR) for the maximum output power specified in Table 6.2.2E-1 due to higher order modulation and transmit bandwidth configuration (resource blocks) is specified in Table 6.2.3E-3, Table 6.2.3E-4 and Table 6.2.3E-6 respectively.

For subPRB allocation of category M1 UE of Power Class 3, there is no MPR applies. For subPRB allocation of category M2 UE of Power Class 3, the allowed MPR due to higher order modulation and transmit bandwidth configuration (subcarrier) is specified in Table 6.2.3E-7.

**Table 6.2.3E-1: Maximum Power Reduction (MPR) for category M1 UE for Power Class 2 and 3**

Modulation	Channel bandwidth / Transmission bandwidth ( $N_{RB}$ )						MPR (dB)
	1.4 MHz	3.0 MHz	5 MHz	10 MHz	15 MHz	20 MHz	
QPSK	>2	>2	>1	>4	-	-	≤ 1
QPSK	>5	>5	-	-	-	-	≤ 2
16 QAM	≤ 2	≤ 2	>1	>3	-	-	≤ 1
16QAM	>2	>2	>3	>5	-	-	≤ 2

NOTE: MPR only applicable for  $N_{RB} \geq 1$

**Table 6.2.3E-2: Maximum Power Reduction (MPR) for category M1 for Power Class 5**

Modulation	Channel bandwidth / Transmission bandwidth ( $N_{RB}$ )						MPR (dB)
	1.4 MHz	3.0 MHz	5 MHz	10 MHz	15 MHz	20 MHz	
QPSK	>2	>2	>3	>5	-	-	≤ 1
QPSK	>5	>5	-	-	-	-	≤ 2
16 QAM	≤ 2	≤ 2	>3	>5	-	-	≤ 1
16QAM	>2	>2	>5	-	-	-	≤ 2

NOTE: MPR only applicable for  $N_{RB} \geq 1$

Table 6.2.3E-3: Maximum Power Reduction (MPR) for category M2 UE for Power Class 2 and 3

Modulation	Channel bandwidth / Transmission bandwidth ( $N_{RB}$ )						MPR (dB)
	1.4 MHz	3.0 MHz	5 MHz	10 MHz	15 MHz	20 MHz	
QPSK	>2	>2	>1	>4	> 16	> 18	$\leq 1$
QPSK	>5	>5	-	-	-	-	$\leq 2$
16 QAM	$\leq 2$	$\leq 2$	>1	>3	$\leq 16$	$\leq 18$	$\leq 1$
16QAM	>2	>2	>3	>5	> 16	> 18	$\leq 2$

NOTE: MPR only applicable for  $N_{RB} \geq 1$

Table 6.2.3E-4: Maximum Power Reduction (MPR) for category M2 UE for Power Class 5

Modulation	Channel bandwidth / Transmission bandwidth ( $N_{RB}$ )						MPR (dB)
	1.4 MHz	3.0 MHz	5 MHz	10 MHz	15 MHz	20 MHz	
QPSK	>2	>2	>3	>5	> 16	> 18	$\leq 1$
QPSK	>5	>5	-	-	-	-	$\leq 2$
16 QAM	$\leq 2$	$\leq 2$	>3	>5	$\leq 16$	$\leq 18$	$\leq 1$
16QAM	>2	>2	>5	-	> 16	> 18	$\leq 2$

NOTE: MPR only applicable for  $N_{RB} \geq 1$

Table 6.2.3E-5: Maximum Power Reduction (MPR) for category M1 for Power Class 6

Modulation	Channel bandwidth / Transmission bandwidth ( $N_{RB}$ )						MPR (dB)
	1.4 MHz	3.0 MHz	5 MHz	10 MHz	15 MHz	20 MHz	
QPSK	>2	>2	>3	>5	-	-	$\leq 1$
QPSK	>5	>5	-	-	-	-	$\leq 2$
16 QAM	$\leq 2$	$\leq 2$	>3	>5	-	-	$\leq 1$
16QAM	>2	>2	>5	-	-	-	$\leq 2$

Table 6.2.3E-6: Maximum Power Reduction (MPR) for category M2 UE for Power Class 6

Modulation	Channel bandwidth / Transmission bandwidth ( $N_{RB}$ )						MPR (dB)
	1.4 MHz	3.0 MHz	5 MHz	10 MHz	15 MHz	20 MHz	
QPSK	>2	>2	>3	>5	> 16	> 18	$\leq 1$
QPSK	>5	>5	-	-	-	-	$\leq 2$
16 QAM	$\leq 2$	$\leq 2$	>3	>5	$\leq 16$	$\leq 18$	$\leq 1$
16QAM	>2	>2	>5	-	> 16	> 18	$\leq 2$

Table 6.2.3E-7: Maximum Power Reduction (MPR) for category M2 UE for Power Class 3 for subPRB allocation

Channel bandwidth	5 MHz		10 MHz		15MHz			
	BPSK	QPSK	BPSK	QPSK	BPSK	QPSK		
WB index for 2 subcarrier transmission	0	-	0	1	-	0	2	-
MPR	$\leq[0.5]$	-	$\leq[0.5]$	$\leq[0.5]$	-	$\leq[0.5]$	$\leq[0.5]$	-
WB index for 3 subcarrier transmission	-	0	-	0	1	-	0	2
MPR	-	$\leq[2]$	-	$\leq[2]$	$\leq[2]$	-	$\leq[2]$	$\leq[2]$
WB index for 6 subcarrier transmission	-	0	-	0	1	-	0	2
MPR	-	$\leq[1]$	-	$\leq[1]$	$\leq[1]$	-	$\leq[1]$	$\leq[1]$

NOTE: WB is specified in TS 36.211 [4]

For PRACH, PUCCH and SRS transmissions, the allowed MPR is according to that specified for PUSCH QPSK modulation for the corresponding transmission bandwidth.

For each subframe, the MPR is evaluated per slot and given by the maximum value taken over the transmission(s) within the slot; the maximum MPR over the two slots is then applied for the entire subframe.

For the UE maximum output power modified by MPR, the power limits specified in subclause 6.2.5 apply.

No other MPR requirement than those specified in tables 6.2.3E-1 and Table 6.2.3E-2 and Table 6.2.3E-5 applies to category M1 and those specified in tables 6.2.3E-3 and Table 6.2.3E-4 and Table 6.2.3E-6 applies to category M2 UE.

### 6.2.3F UE maximum output power for modulation / channel bandwidth for category NB1 and NB2

For UE category NB1 and NB2 power class 3 and 5 the allowed Maximum Power Reduction (MPR) for the maximum output power given in Table 6.2.2F-1 is specified in Table 6.2.3F-1.

**Table 6.2.3F-1: Maximum Power Reduction (MPR) for UE category NB1 and NB2 Power Class 3 and 5**

Modulation	QPSK		
<b>Tone positions for 3 Tones allocation</b>	0-2	3-5 and 6-8	9-11
<b>MPR</b>	≤ 0.5 dB	0 dB	≤ 0.5 dB
<b>Tone positions for 6 Tones allocation</b>	0-5 and 6-11		
<b>MPR</b>	≤ 1 dB	≤ 1 dB	
<b>Tone positions for 12 Tones allocation</b>	0-11		
<b>MPR</b>	≤ 2 dB		

For UE category NB1 and NB2 power class 6 the allowed Maximum Power Reduction (MPR) for the maximum output power given in Table 6.2.2F-1 is specified in Table 6.2.3F-2.

**Table 6.2.3F-2: Maximum Power Reduction (MPR) for UE category NB1 and NB2 Power Class 6**

Modulation	QPSK
<b>MPR for 3 Tones allocation</b>	≤ 0.5 dB
<b>MPR for 6 Tones allocation</b>	≤ 1 dB
<b>MPR for 12 Tones allocation</b>	≤ 1.5 dB

For the UE maximum output power modified by MPR, the power limits specified in sub-clause 6.2.5F apply.

### 6.2.3G UE maximum output power for modulation / channel bandwidth for V2X Communication

When UE is configured for E-UTRA V2X sidelink transmissions non-concurrent with E-UTRA uplink transmissions for E-UTRA V2X operating bands specified in Table 5.5G-1, this subclause specifies the allowed Maximum Power Reduction (MPR) power for V2X physical channels and signals due to PSCCH and PSSCH simultaneous transmission.

#### 6.2.3G.1 MPR for Power class 3 V2X UE

For contiguous allocation of PSCCH and PSSCH simultaneous transmission, the allowed MPR for the maximum output power for V2X physical channels PSCCH and PSSCH shall be as specified in Table 6.2.3G.1-1 for power class 3.

**Table 6.2.3G.1-1: Maximum Power Reduction (MPR) for power class 3 V2X Communication (Contiguous PSCCH and PSSCH transmission)**

Modulation	Channel bandwidth / Transmission bandwidth ( $N_{RB}$ )						MPR (dB)
	1.4 MHz	3.0 MHz	5 MHz	10 MHz	15 MHz	20 MHz	
QPSK							$\leq 1.5$
16 QAM							$\leq 2$
64QAM							$\leq 3$

For non-contiguous allocation of PSCCH and PSSCH simultaneous transmission, the allowed MPR for the maximum output power for V2X physical channels PSCCH and PSSCH shall be as specified as follows

$$MPR = \text{CEIL} \{M_A, 0.5\}$$

Where  $M_A$  is defined as follows

$$M_A = \begin{cases} 4.5 & ; 0.00 < A \leq 0.2 \\ 5.5 - 5.833A & ; 0.2 < A \leq 0.6 \\ 2.0 & ; 0.6 < A \leq 1.00 \end{cases}$$

Where

$$A = N_{RB\_alloc} / N_{RB}$$

$\text{CEIL}\{M_A, 0.5\}$  means rounding upwards to closest 0.5dB.

The allowed MPR for the maximum output power for V2X physical channels PSBCH and PSSS shall be as specified in subclause 6.2.3 for the corresponding modulation and transmission bandwidth.

The allowed MPR for the maximum output power for V2X physical signal SSSS is specified in Table 6.2.3D-1.

When UE is configured for simultaneous E-UTRA V2X sidelink and E-UTRA uplink transmissions for inter-band E-UTRA V2X / E-UTRA bands specified in Table 5.5G-2, the allowed MPR requirements in subclause 6.2.3G apply for V2X PSSCH and PSCCH transmission. The allowed MPR requirements in subclause 6.2.3D apply for other V2X sidelink transmission (PSBCH/PSSS/SSSS). The MPR requirements in subclause 6.2.3 apply for uplink transmission.

For intra-band contiguous multi-carrier operation bandwidth class B the allowed Maximum Power Reduction (MPR) for the maximum output power in Table 6.2.2G.1-2 due to higher order modulation is specified as follows.

**Table 6.2.3G.1-2: Void**

$$MPR = \text{CEIL} \{M_A, 0.5\}$$

Where  $M_A$  is defined as follows for QPSK, 16 QAM and 64 QAM

$$M_A = \begin{cases} 6.5 & ; 0 \leq A < 0.1 \\ 8 - 15A & ; 0.1 \leq A < 0.2 \\ 5.75 - 3.75A & ; 0.2 \leq A < 0.6 \end{cases}$$

3.5 ;  $0.6 \leq A \leq 1$  For intra-band contiguous multi-carrier operation bandwidth class C the allowed Maximum Power Reduction (MPR) for the maximum output power can be specified as follows. In case the modulation format is different on different component carriers then the MPR is determined by the rules applied to higher order of those modulations.

$$MPR = \text{CEIL} \{M_A, 0.5\}$$

Where  $M_A$  is defined as follows for QPSK, 16 QAM and 64 QAM

$$M_A = \begin{cases} 6.5 & ; 0 \leq A < 0.1 \end{cases}$$

8.5 - 20A	; $0.1 \leq A < 0.2$
5.25 - 2.5A	; $0.2 \leq A < 0.6$
3.5	; $0.6 \leq A \leq 1$

### 6.2.3G.2 MPR for Power class 2 V2X UE

For contiguous allocation of PSCCH and PSSCH simultaneous transmission, the allowed MPR for the maximum output power for V2X physical channels PSCCH and PSSCH shall be as specified in Table 6.2.3G.2-1 for power class 2.

**Table 6.2.3G.2-1: Maximum Power Reduction (MPR) for power class 2 V2X Communication (Contiguous PSCCH and PSSCH transmission)**

Modulation	Channel bandwidth / Transmission bandwidth ( $N_{RB}$ )						MPR (dB)
	1.4 MHz	3.0 MHz	5 MHz	10 MHz	15 MHz	20 MHz	
QPSK							$\leq 2$
16 QAM							$\leq 2.5$
64QAM							$\leq 3$

For non-contiguous allocation of PSCCH and PSSCH simultaneous transmission, the allowed MPR for the maximum output power for V2X physical channels PSCCH and PSSCH shall be as specified as follows:

$$MPR = \text{CEIL} \{M_A, 0.5\}$$

Where  $M_A$  is defined as follows

For 10MHz channel bandwidth	$M_A = 4.5$	; $0.0 < A \leq 0.2$
	8.5 - 20.0A	; $0.2 < A \leq 0.3$
	2.5	; $0.3 < A \leq 1.00$
For 20MHz channel bandwidth	$M_A = 9.0$	; $0.0 < A \leq 0.1$
	12.0 - 30.0A	; $0.1 < A \leq 0.3$
	3.0	; $0.3 < A \leq 1.00$

Where

$$A = N_{RB\_alloc} / N_{RB}$$

$\text{CEIL}\{M_A, 0.5\}$  means rounding upwards to closest 0.5dB.

### 6.2.4 UE maximum output power with additional requirements

Additional ACLR and spectrum emission requirements can be signalled by the network to indicate that the UE shall also meet additional requirements in a specific deployment scenario. To meet these additional requirements, Additional Maximum Power Reduction (A-MPR) is allowed for the output power as specified in Table 6.2.2-1. Unless stated otherwise, an A-MPR of 0 dB shall be used.

For UE Power Class 1, 2 and 3 the specific requirements and identified subclauses are specified in Table 6.2.4-1 along with the allowed A-MPR values that may be used to meet these requirements. The allowed A-MPR values specified below in Table 6.2.4.-1 to 6.2.4-15 are in addition to the allowed MPR requirements specified in subclause 6.2.3.

**Table 6.2.4-1: Additional Maximum Power Reduction (A-MPR)**



Network Signalling value	Requirements (subclause)	E-UTRA Band	Channel bandwidth (MHz)	Resources Blocks ( $N_{RB}$ )	A-MPR (dB)
NS_01	6.6.2.1.1	Table 5.5-1	1.4, 3, 5, 10, 15, 20	Table 5.6-1	N/A
NS_03	6.6.2.2.1	2, 4, 10, 23, 25, 35, 36, 66, 70	3	>5	$\leq 1$
			5	>6	$\leq 1$
			10	>6	$\leq 1$
			15	>8	$\leq 1$
			20	>10	$\leq 1$
NS_04	6.6.2.2.2, 6.6.3.3.19	41	5, 10, 15, 20	Table 6.2.4-4, Table 6.2.4-4a	
NS_05	6.6.3.3.1	1	10, 15, 20	$\geq 50$ (NOTE1)	$\leq 1$ (NOTE1)
			15, 20	Table 6.2.4-18 (NOTE2)	
		65 (NOTE 3)	10, 15, 20	$\geq 50$	$\leq 1$ (NOTE 1)
			15, 20	Table 6.2.4-18 (NOTE 2)	
NS_06	6.6.2.2.3	12, 13, 14, 17	1.4, 3, 5, 10	Table 5.6-1	N/A
		85	5, 10	Table 5.6-1	N/A
NS_07	6.6.2.2.3, 6.6.3.3.2	13	10	Table 6.2.4-2	
NS_08	6.6.3.3.3	19	10, 15	> 44	$\leq 3$
NS_09	6.6.3.3.4	21	10, 15	> 40	$\leq 1$
				> 55	$\leq 2$
		74 (NOTE 6)	10, 15	> 40	$\leq 1$
				> 55	$\leq 2$
NS_10		20	15, 20	Table 6.2.4-3	
NS_11	6.6.2.2.1, 6.6.3.3.13	23	1.4, 3, 5, 10, 15, 20	Table 6.2.4-5	
NS_12	6.6.3.3.5	26	1.4, 3, 5, 10, 15	Table 6.2.4-6	
NS_13	6.6.3.3.6	26	5	Table 6.2.4-7	
NS_14	6.6.3.3.7	26	10, 15	Table 6.2.4-8	
NS_15	6.6.3.3.8	26	1.4, 3, 5, 10, 15	Table 6.2.4-9, Table 6.2.4-10	
NS_16	6.6.3.3.9	27	3, 5, 10	Table 6.2.4-11, Table 6.2.4-12, Table 6.2.4-13	
NS_17	6.6.3.3.10	28	5, 10	Table 5.6-1	N/A
NS_18	6.6.3.3.11	28	5	$\geq 2$	$\leq 1$
			10, 15, 20	$\geq 1$	$\leq 4$
NS_19	6.6.3.3.12	44	10, 15, 20	Table 6.2.4-14	
NS_20	6.2.2, 6.6.2.2.1, 6.6.3.3.14	23	5, 10, 15, 20	Table 6.2.4-15	
	6.6.2.2.1, 6.6.3.3.15			Table 6.2.4-16	
NS_22	6.6.3.3.16	42(NOTE 8), 43	5, 10, 15, 20	Table 6.2.4-17	
NS_23	6.6.3.3.17	42(NOTE 8), 43	5, 10, 15, 20	N/A	
NS_24	6.6.3.3.20	65 (NOTE 4)	5, 10, 15, 20	Table 6.2.4-19	
NS_25	6.6.3.3.21	65 (NOTE 4)	5, 10, 15, 20	Table 6.2.4-20	
NS_26	6.6.3.3.22	68	10, 15	Table 6.2.4-21	
NS_27	6.6.2.2.5, 6.6.3.3.23	48	5, 10, 15, 20	Table 6.2.4-22	
NS_28	6.2.2A, 6.6.2.2.6, 6.6.3.3.24	46 (NOTE 5)	20	Table 6.2.4-23	
NS_29	6.2.2A, 6.6.2.3.1a, 6.6.3.3.25	46 (NOTE 5)	20	Table 6.2.4-24	
NS_30	6.2.2A, 6.6.3.3.26	46 (NOTE 5)	20	Table 6.2.4-25	
NS_31	6.2.2A, 6.6.3.3.27	46 (NOTE 5)	20	Table 6.2.4-26	
NS_32	-	-	-	-	-
...					
NS_35	6.6.2.2.7	71	5, 10, 15, 20	N/A	

NS_36	6.6.3.3.28	68	5, 10, 15	Table 6.2.4-27
NS_38	6.6.3.3.29	74	1.4, 3, 5, 10, 15, 20	Table 6.2.4-28
NS_39	6.6.3.3.30	74	10, 15, 20	Table 6.2.4-29
NS_40	6.6.3.3.31	51	3, 5	Table 6.2.4-30a, Table 6.2.4-30b
NS_41	6.6.3.3.31	50	3, 5, 10, 15, 20	Table 6.2.4-31
NS_42	6.6.3.3.32	50	3, 5, 10, 15, 20	Table 6.2.4-32
NS_43	6.6.2.2.5 6.6.3.3.23	49	20	Table 6.2.4-33
NS_44	6.6.3.3.33	38 (Note 7)	5, 10, 15, 20	Table 6.2.4-34
NS_45	6.6.3.3.34	53	1.4, 3, 5, 10	N/A
<p>NOTE 1: Applicable when the lower edge of the assigned E-UTRA UL channel bandwidth frequency is larger than or equal to the upper edge of PHS band (1915.7 MHz) + 4 MHz + the channel BW assigned, where channel BW is as defined in subclause 5.6. A-MPR for operations below this frequency is not covered in this version of specifications except for the channel assignments in NOTE2 as the emissions requirement in 6.6.3.3.1 may not be met. For 10MHz channel bandwidth whose carrier frequency is larger than or equal to 1945 MHz or 15 MHz channel bandwidth whose carrier frequency is larger than or equal to 1947.5 MHz, no A-MPR applies.</p> <p>NOTE 2: Applicable when carrier frequency is 1932.5 MHz for 15MHz channel bandwidth or 1930 MHz for 20MHz channel bandwidth case.</p> <p>NOTE 3: Applicable when the E-UTRA carrier is within 1920-1980 MHz.</p> <p>NOTE 4: Applicable when the upper edge of the channel bandwidth frequency is greater than 1980MHz.</p> <p>NOTE 5: Applicable only for an LAA Scell configured in Band 46.</p> <p>NOTE 6: Applicable when the E-UTRA carrier is within 1447.9 – 1462.9 MHz</p> <p>NOTE 7: Applicable for power class 2 UE in E-UTRA carrier with channel bandwidth is confined within 2570 MHz and 2615 MHz</p> <p>NOTE 8: Not applicable for power class 2 UE in Band 42</p>				

Table 6.2.4-2: A-MPR for "NS\_07"

Parameters	Region A		Region B		Region C
RB <sub>start</sub>	0 - 12		13 – 18	19 – 42	43 – 49
L <sub>CRB</sub> [RBs]	6-8	1 to 5 and 9-50	≥8	≥18	≤2
A-MPR [dB]	≤ 8	≤ 12	≤ 12	≤ 6	≤ 3
<p>NOTE 1; RB<sub>start</sub> indicates the lowest RB index of transmitted resource blocks</p> <p>NOTE 2; L<sub>CRB</sub> is the length of a contiguous resource block allocation</p> <p>NOTE 3: For intra-subframe frequency hopping between two regions, notes 1 and 2 apply on a per slot basis. For intra-slot or intra-subslot frequency hopping between two regions, notes 1 and 2 apply on a per T<sub>no_hopping</sub> basis.</p> <p>NOTE 4; For intra-subframe frequency hopping between two regions, the larger A-MPR value of the two regions may be applied for both slots in the subframe. For intra-slot frequency hopping between two regions, the larger A-MPR value of the two regions may be applied for the slot. For intra-subslot frequency hopping between two regions, the larger A-MPR value of the two regions may be applied for the subslot.</p>					

Table 6.2.4-3: A-MPR for "NS\_10"

Channel bandwidth [MHz]	Parameters	Region A
15	RB <sub>start</sub>	0 – 10
	L <sub>CRB</sub> [RBs]	1 -20
	A-MPR [dB]	≤ 2
20	RB <sub>start</sub>	0 – 15
	L <sub>CRB</sub> [RBs]	1 -20
	A-MPR [dB]	≤ 5

NOTE 1: RB<sub>start</sub> indicates the lowest RB index of transmitted resource blocks  
NOTE 2: L<sub>CRB</sub> is the length of a contiguous resource block allocation  
NOTE 3: For intra-subframe frequency hopping which intersects Region A, notes 1 and 2 apply on a per slot basis. For intra-slot or intra-subslot frequency hopping which intersects Region A, notes 1 and 2 apply on a T<sub>no\_hopping</sub> basis.  
NOTE 4: For intra-subframe frequency hopping which intersect Region A, the larger A-MPR value may be applied for both slots in the subframe. For intra-slot frequency hopping which intersects Region A, the larger A-MPR value may be applied for the slot. For intra-subslot frequency hopping which intersects Region A, the larger A-MPR value may be applied for the subslot.

Table 6.2.4-4: A-MPR requirements for "NS\_04" for Power Class 3 UE

Channel bandwidth [MHz]	Parameters						
	F <sub>c</sub> [MHz]	≤ 2500.5			> 2500.5		
5	RB <sub>start</sub>	0 - 8			9 - 24	0 - 24	
	L <sub>CRB</sub> [RBs]	> 0			> 0	> 0	
	A-MPR [dB]	≤ 2			0	0	
	F <sub>c</sub> [MHz]	≤ 2504			> 2504		
10	RB <sub>start</sub>	0 - 8			9 - 35	36 - 49	0 - 49
	L <sub>CRB</sub> [RBs]	≤ 15	> 15 and < 25	≥ 25	N/A	> 0	> 0
	RB <sub>start</sub> + L <sub>CRB</sub> [RBs]	N/A	N/A	N/A	≥ 45	N/A	N/A
	A-MPR [dB]	≤ 3	≤ 1	≤ 2	≤ 1	0	0
	F <sub>c</sub> [MHz]	≤ 2510.8			> 2510.8		
15	RB <sub>start</sub>	0 - 13			14 - 59	60 - 74	0 - 74
	L <sub>CRB</sub> [RBs]	≤ 18 or ≥ 36	> 18 and < 36		N/A	> 0	> 0
	RB <sub>start</sub> + L <sub>CRB</sub> [RBs]	N/A	N/A		≥ 62	N/A	N/A
	A-MPR [dB]	≤ 3	≤ 1		≤ 1	0	0
	F <sub>c</sub> [MHz]	≤ 2517.5			> 2517.5		
20	RB <sub>start</sub>	0 - 22			23 - 76	77 - 99	0 - 99
	L <sub>CRB</sub> [RBs]	≤ 18 or ≥ 40	> 18 and < 40		N/A	> 0	> 0
	RB <sub>start</sub> + L <sub>CRB</sub> [RBs]	N/A	N/A		≥ 86	N/A	N/A
	A-MPR [dB]	≤ 3	≤ 1		≤ 1	0	0
	F <sub>c</sub> [MHz]	≤ 2517.5			> 2517.5		

NOTE 1: RB<sub>start</sub> indicates the lowest RB index of transmitted resource blocks  
NOTE 2: L<sub>CRB</sub> is the length of a contiguous resource block allocation  
NOTE 3: For intra-subframe frequency hopping which intersects regions, notes 1 and 2 apply on a per slot basis. For intra-slot or intra-subslot frequency hopping which intersects regions, notes 1 and 2 apply on a per T<sub>no\_hopping</sub> basis.  
NOTE 4: For intra-subframe frequency hopping which intersects regions, the larger A-MPR value may be applied for both slots in the subframe. For intra-slot frequency hopping which intersects regions, the larger A-MPR value may be applied for the slot. For intra-subslot frequency hopping which intersects regions, the larger A-MPR value may be applied for the subslot.

Table 6.2.4-4a: A-MPR requirements for "NS\_04" for Power Class 2 UE

Channel bandwidth [MHz]	Parameters						
5	Fc [MHz]	$\leq 2500.5$				$> 2500.5$	
	RB <sub>start</sub>	0 - 8		9 - 24		0 - 24	
	LCRB [RBs]	$> 0$		$> 0$		$> 0$	
	A-MPR [dB]	$\leq 3$		0		0	
10	Fc [MHz]	$\leq 2504$				$> 2504$	
	RB <sub>start</sub>	0 - 8				0 - 49	
	LCRB [RBs]	$\leq 15$	$> 15$ and $< 25$	$\geq 25$	N/A	$> 0$	$> 0$
	RB <sub>start</sub> + LCRB [RBs]	N/A	N/A	N/A	$\geq 45$	N/A	N/A
	A-MPR [dB]	$\leq 5$	$\leq 2$	$\leq 3$	$\leq 1$	0	0
	15	Fc [MHz]	$\leq 2510.8$				$> 2510.8$
RB <sub>start</sub>		0 - 13				0 - 74	
LCRB [RBs]		$\leq 18$	$> 18$ and $< 36$	$\geq 36$	N/A	$> 0$	$> 0$
RB <sub>start</sub> + LCRB [RBs]		N/A	N/A	N/A	$\geq 62$	N/A	N/A
A-MPR [dB]		$\leq 5$	$\leq 2$	$\leq 4$	$\leq 3$	0	0
20		Fc [MHz]	$\leq 2517.5$				$> 2517.5$
	RB <sub>start</sub>	0 - 22				0 - 99	
	LCRB [RBs]	$\leq 18$	$> 18$ and $< 40$	$\geq 40$	N/A	$> 0$	$> 0$
	RB <sub>start</sub> + LCRB [RBs]	N/A	N/A	N/A	$\geq 86$	N/A	N/A
	A-MPR [dB]	$\leq 5$	$\leq 2$	$\leq 4$	$\leq 3$	0	0
	<p>NOTE 1: RB<sub>start</sub> indicates the lowest RB index of transmitted resource blocks</p> <p>NOTE 2: LCRB is the length of a contiguous resource block allocation</p> <p>NOTE 3: For intra-subframe frequency hopping which intersects regions, notes 1 and 2 apply on a per slot basis. For intra-slot or intra-subslot frequency hopping which intersects regions, notes 1 and 2 apply on a per T<sub>no,hopping</sub> basis.</p> <p>NOTE 4: For intra-subframe frequency hopping which intersects regions, the larger A-MPR value may be applied for both slots in the subframe. For intra-slot frequency hopping which intersects regions, the larger A-MPR value may be applied for the slot. For intra-subslot frequency hopping which intersects regions, the larger A-MPR value may be applied for the subslot.</p>						

For a power class 2 capable UE operating in Band 41, A-MPR according to Table 6.2.4-4 for power class 3 is allowed when an IE *P-max* as defined in [7] of 23 dBm or lower is indicated in the cell or if the uplink/downlink configuration is 0 or 6.

Table 6.2.4-5: A-MPR for "NS\_11"

Channel Bandwidth [MHz]	Parameters					
	Fc [MHz]	<2004		≥2004		
3	LCRB [RBs]	1-15		>5		
	A-MPR [dB]	≤5		≤1		
	Fc [MHz]	<2004		2004 ≤ Fc <2007		≥2007
5	LCRB [RBs]	1-25		1-6 & 15-25	8-12	>6
	A-MPR [dB]	≤7		≤4	0	≤1
	Fc [MHz]	2005 ≤ Fc <2015			2015	
10	RB <sub>start</sub>	0-49			0-49	
	LCRB [RBs]	1-50			1-50	
	A-MPR [dB]	≤12			0	
	Fc [MHz]	<2012.5				
15	RB <sub>start</sub>	0-4	5-21		22-56	57-74
	LCRB [RBs]	≥1	7-50	0-6 & ≥50	≤25	>25
	A-MPR [dB]	≤15	≤7	≤10	0	≤6
	Fc [MHz]	2012.5				
	RB <sub>start</sub>	0-12	13-39		40-65	66-74
	LCRB [RBs]	≥1	≥30	<30	≥ (69 – RB <sub>start</sub> )	≥1
	A-MPR [dB]	≤10	≤6	0	≤2	≤6.5
	Fc [MHz]	2010				
20	RB <sub>start</sub>	0-12	13-29		30-68	69-99
	LCRB [RBs]	≥1	10-60	1-9 & >60	1-24	≥25
	A-MPR [dB]	≤15	≤7	≤10	0	≤7
	A-MPR [dB]	≤15	≤7	≤10	0	≤7

Table 6.2.4-6: A-MPR for "NS\_12"

Channel bandwidth [MHz]	Parameters	Region A		Region B
1.4	RB <sub>start</sub>	0		1-2
	LCRB [RBs]	≤3	≥4	≥4
	A-MPR [dB]	≤3	≤6	≤3
3	RB <sub>start</sub>	0-3		4-5
	LCRB [RBs]	1-15		≥9
	A-MPR [dB]	≤4		≤3
5	RB <sub>start</sub>	0-6		0-9
	LCRB [RBs]	≤8		≥9
	A-MPR [dB]	≤5		≤3
10	RB <sub>start</sub>	0-15		0-22
	LCRB [RBs]	≤18		≥20
	A-MPR [dB]	≤4		≤2
15	RB <sub>start</sub>	0-30		0-30
	LCRB [RBs]	≤30		≥32
	A-MPR [dB]	≤4		≤3

Table 6.2.4-7: A-MPR for "NS\_13"

Channel bandwidth [MHz]	Parameters	Region A	
		5	RB <sub>start</sub>
	L <sub>CRB</sub> [RBs]	≤5	≥18
	A-MPR [dB]	≤3	≤2

Table 6.2.4-8: A-MPR for "NS\_14"

Channel bandwidth [MHz]	Parameters	Region A	
		10	RB <sub>start</sub>
	L <sub>CRB</sub> [RBs]	≤5	≥50
	A-MPR [dB]	≤3	≤1
15	RB <sub>start</sub>	≤8	
	L <sub>CRB</sub> [RBs]	≤16	≥50
	A-MPR [dB]	≤3	≤1

Table 6.2.4-9: A-MPR for "NS\_15" for E-UTRA highest channel edge &gt; 845 MHz and ≤ 849 MHz

Channel bandwidth [MHz]	Parameters	Region A	Region B	Region C
1.4	RB <sub>end</sub> [RB]			4-5
	A-MPR [dB]			≤3
3	RB <sub>end</sub> [RB]	0-1	8-12	13-14
	L <sub>CRB</sub> [RB]	≤2	≥8	>0
	A-MPR [dB]	≤4	≤4	≤9
5	RB <sub>end</sub> [RB]	0-4	12-19	20-24
	L <sub>CRB</sub> [RB]	≤2	≥8	>0
	A-MPR [dB]	≤4	≤5	≤9
10	RB <sub>end</sub> [RB]	0-12	23-36	37-49
	L <sub>CRB</sub> [RB]	≤2	≥15	>0
	A-MPR [dB]	≤4	≤6	≤9
15	RB <sub>end</sub> [RB]	0-20	26-53	54-74
	L <sub>CRB</sub> [RB]	≤2	≥20	>0
	A-MPR [dB]	≤4	≤5	≤9

Table 6.2.4-10: A-MPR for "NS\_15" for E-UTRA highest channel edge ≤ 845 MHz

Channel bandwidth [MHz]	Parameters	Region A	Region B	Region C
5	RB <sub>end</sub> [RB]			19-24
	L <sub>CRB</sub> [RB]			≥18
	A-MPR [dB]			≤2
10	RB <sub>end</sub> [RB]	0-4	29-44	45-49
	L <sub>CRB</sub> [RB]	≤2	≥24	>0
	A-MPR [dB]	≤4	≤4	≤9
15	RB <sub>end</sub> [RB]	0-12	44-61	62-74
	L <sub>CRB</sub> [RB]	≤2	≥20	>0
	A-MPR [dB]	≤4	≤5	≤9

Table 6.2.4-11: A-MPR for "NS\_16" with channel lower edge at  $\geq 807$  MHz and  $< 808.5$  MHz

Channel bandwidth [MHz]	Parameter	Region A	Region B	Region C	Region D	Region E
3 MHz	RB <sub>start</sub>	0	1-2			
	LCRB [RBs]	$\geq 12$	12			
	A-MPR [dB]	$\leq 2$	$\leq 1$			
5 MHz	RB <sub>start</sub>	0-1	2	2-9	2-5	
	LCRB [RBs]	1 - 25	12	15-18	20	
	A-MPR [dB]	$\leq 5$	$\leq 1$	$\leq 2$	$\leq 3$	
10 MHz	RB <sub>start</sub>	0 - 8	0-14		15-20	15-24
	LCRB [RBs]	1 - 12	15-20	$\geq 24$	$\geq 30$	24-27
	A-MPR [dB]	$\leq 5$	$\leq 3$	$\leq 7$	$\leq 3$	$\leq 1$

Table 6.2.4-12: A-MPR for "NS\_16" with channel lower edge at  $\geq 808.5$  MHz and  $< 812$  MHz

Channel bandwidth [MHz]	Parameter	Region A	Region B	Region C	Region D	Region E
5 MHz	RB <sub>start</sub>	0	0-1	1-5		
	LCRB [RBs]	16-20	$\geq 24$	16-20		
	A-MPR [dB]	$\leq 2$	$\leq 3$	$\leq 1$		
10 MHz	RB <sub>start</sub>	0-6		0-10	0-14	11-20
	LCRB [RBs]	1-12	15-20	24-32	$\geq 36$	24-32
	A-MPR [dB]	$\leq 5$	$\leq 2$	$\leq 4$	$\leq 5$	$\leq 1$

Table 6.2.4-13: A-MPR for "NS\_16" with channel lower edge at  $\geq 812$  MHz

Channel bandwidth [MHz]	Parameter	Region A	Region B	Region C	Region D
10 MHz	RB <sub>start</sub>	0 - 9	0	1-14	0-5
	LCRB [RBs]	27-32	36-40	36-40	$\geq 45$
	A-MPR [dB]	$\leq 1$	$\leq 2$	$\leq 1$	$\leq 3$

Table 6.2.4-14: A-MPR for "NS\_19"

Channel bandwidth [MHz]	Parameters	Region A	Region B
10	RB <sub>start</sub>		0-6
	LCRB [RBs]		$\geq 40$
	A-MPR [dB]		$\leq 1$
15	RB <sub>start</sub>	0-6	
	LCRB [RBs]	$\leq 18$	$\geq 36$
	A-MPR [dB]	$\leq 2$	$\leq 3$
20	RB <sub>start</sub>	0-14	
	LCRB [RBs]	$\leq 40$	$\geq 45$
	A-MPR [dB]	$\leq 2$	$\leq 3$

Table 6.2.4-15: A-MPR for "NS\_20"

Channel Bandwidth [MHz]	Parameters

5	Fc [MHz]	< 2007.5		2007.5 ≤ Fc < 2012.5		2012.5 ≤ Fc ≤ 2017.5	
	RB <sub>start</sub>	≤24		0-3	4-6	≤24	
	LCRB [RBs]	>0		15-19	≥20	≥18	
	A-MPR [dB]	≤17		≤1	≤4	≤2	≤0
10	Fc [MHz]	2005					
	RB <sub>start</sub>	0-25		26-34		35-49	
	LCRB [RBs]	>0		8-15	≥15		>0
	A-MPR [dB]	≤16		≤2	≤5	≤6	
	Fc [MHz]	2015					
	RB <sub>start</sub>	0-5			6-10		
LCRB [RBs]	≥32			≥40			
A-MPR [dB]	≤4			≤2			
15	Fc [MHz]	2012.5					
	RB <sub>start</sub>	0-14		15-24		25-39	61-74
	LCRB [RBs]	1-9 & 40-75	10-39	24-29	≥30	≥36	≤6
	A-MPR [dB]	≤11	≤6	≤1	≤7	≤5	≤6
20	Fc [MHz]	2010					
	RB <sub>start</sub>	0-21	22-31	32-38	39-49	50-68	69-99
	LCRB [RBs]	>0	1-9 & 31-75	10-30	≥15	≥24	≥25
	A-MPR [dB]	≤17	≤12	≤6	≤9	≤7	≤5
	A-MPR [dB]	≤17	≤12	≤6	≤9	≤7	≤5

NOTE 1: When NS\_20 is signaled the minimum requirements for the 10 MHz bandwidth are specified for E-UTRA UL carrier center frequencies of 2005 MHz or 2015 MHz.

NOTE 2: When NS\_20 is signaled the minimum requirements for the 15 MHz channel bandwidth are specified for E-UTRA UL carrier center frequency of 2012.5 MHz.

Table 6.2.4-16: A-MPR for "NS\_21"

Channel Bandwidth [MHz]	Parameters	Region A		Region B	
10	RB <sub>start</sub>	0 – 6	0 – 6	N/A	N/A
	RB <sub>end</sub>	N/A	N/A	43 – 49	43 – 49
	LCRB [RBs]	1 – 2	3 – 12, 32 - 50	1 – 2	3 – 12, 32 - 50
	A-MPR [dB]	≤ 4	≤ 3	≤ 4	≤ 3



Table 6.2.4-17: A-MPR for "NS\_22"

Channel bandwidth [MHz]	Parameters	Region A	Region B	Region C	Region D
5	No A-MPR is needed for 5 MHz channel bandwidth				
10	RB <sub>start</sub>	0-13	0-17	≤ 6	≥ 12
	LCRB [RBs]	> 36	33-36	≤ 32	≤ 32
	RB <sub>start</sub> + LCRB [RBs]	N/A	N/A	N/A	≥ 44
	A-MPR [dB]	≤ 4	≤ 3	≤ 3	≤ 3
15	RB <sub>start</sub>	0-24	0-38	≤ 14	≥ 23
	LCRB [RBs]	> 50	37-50	≤ 36	≤ 36
	RB <sub>start</sub> + LCRB [RBs]	N/A	N/A	N/A	≥ 59
	A-MPR [dB]	≤ 5	≤ 4	≤ 3	≤ 3
20	RB <sub>start</sub>	0-35	0-51	≤ 21	≥ 31
	LCRB [RBs]	> 64	49-64	≤ 48	≤ 48
	RB <sub>start</sub> + LCRB [RBs]	N/A	N/A	N/A	≥ 79
	A-MPR [dB]	≤ 5	≤ 4	≤ 3	≤ 3

NOTE 1; RB<sub>start</sub> indicates the lowest RB index of transmitted resource blocks  
NOTE 2; LCRB is the length of a contiguous resource block allocation  
NOTE 3; For intra-subframe frequency hopping between two regions, notes 1 and 2 apply on a per slot basis. For intra-slot or intra-subslot frequency hopping between two regions, notes 1 and 2 apply on a per T<sub>no\_hopping</sub> basis.  
NOTE 4; For intra-subframe frequency hopping between two regions, the larger A-MPR value of the two regions may be applied for both slots in the subframe. For intra-slot frequency hopping between two regions, the larger A-MPR value may be applied for the slot. For intra-subslot frequency hopping between two regions, the larger A-MPR value may be applied for the subslot.

Table 6.2.4-18: A-MPR for "NS\_05"

Channel Bandwidth [MHz]	Parameters							
15	Fc [MHz]	1932.5						
	RB <sub>start</sub>	0-7	8 – 66			67-74		
	LCRB [RBs]	≥ 1	≤ 30	31 – 54	> 54	≤ 6	> 6	
	A-MPR [dB]	≤ 11	0	≤ 3	≤ 5	≤ 5	≤ 1	
20	Fc [MHz]	1930						
	RB <sub>start</sub>	0-23	24-75			76-99		
	LCRB [RBs]	≥ 1	≤ 24	25 – 40	41 – 50	> 50	≤ 6	> 6
	A-MPR [dB]	≤ 11	0	≤ 3	≤ 5	≤ 10	≤ 5	≤ 1

Table 6.2.4-18E: A-MPR requirements for "NS\_05" for Cat-M2 power class 3 UE

BW [MHz]	20				
Fc [MHz]	1930				
(NB <sub>index</sub> , RB <sub>start</sub> )	(0, <6)	(0, <6)	(1, <6)	(2, <6)	(2, <6)
LCRB	9, 12	≥ 15	≥ 15	18	24
A-MPR [dB]	≤ 1	≤ 4	≤ 3	≤ 1	≤ 2

NOTE 1: NB<sub>index</sub> is the narrowband index that is defined in 6.2.7 in [4]. The resource block assignment is defined within the narrowband as defined in 5.3.3.1.12 and 5.3.3.1.13 in [5].

Table 6.2.4-19: A-MPR for "NS\_24"

Channel Bandwidth [MHz]	Parameters								
5	Fc [MHz]	Fc > [1987.5]							
	RB <sub>start</sub>	0 - 24							
	L <sub>CRB</sub> [RBs]	0 - 24							
	A-MPR [dB]	≤ 10							
10	Fc [MHz]	1975 < Fc ≤ 1985				1985 < Fc ≤ 1995		Fc > 1995	
	RB <sub>start</sub>	0 - 1	2 - 14	15 - 26	36 - 49	0 - 49		0 - 49	
	L <sub>CRB</sub> [RBs]	> 10	≥ 35	N/A	≤ 2	> 11	0 - 49	0 - 49	
	RB <sub>end</sub>	N/A	N/A	> 48	N/A	N/A	N/A	N/A	
	A-MPR [dB]	≤ 2	≤ 2	1	≤ 3	≤ 1	≤ 9	≤ 17	
15	Fc [MHz]	1972.5 < Fc ≤ 1987.5				Fc > 1987.5			
	RB <sub>start</sub>	0 - 11			12 - 74		0 - 74		
	L <sub>CRB</sub> [RBs]	≤ 45		> 45		> 3		0 - 74	
	RB <sub>end</sub>	N/A		N/A		≥ 45		N/A	
	A-MPR [dB]	≤ 2		≤ 8		≤ 7		≤ 17	
20	Fc [MHz]	Fc > 1970							
	RB <sub>start</sub>	0 - 99							
	L <sub>CRB</sub> [RBs]	0 - 99							
	A-MPR [dB]	≤ 17							

Table 6.2.4-20: A-MPR for "NS\_25"

Channel Bandwidth [MHz]	Parameters										
5	Fc [MHz]	Fc > [1997.5]									
	RB <sub>start</sub>	0 - 9				10 - 24					
	L <sub>CRB</sub> [RBs]	> 12				N/A					
	RB <sub>end</sub>	N/A				≥ 22					
	A-MPR [dB]	≤ 5				≤ 2					
10	Fc [MHz]	1975 < Fc ≤ 1985			1985 < Fc ≤ 1995			Fc > 1995			
	RB <sub>start</sub>	0-1	2-49	0	1 - 18	19-49	0-6	7-15	16-49		
	L <sub>CRB</sub> [RBs]	> 10	N/A	≤ 25	> 25	N/A	N/A	> 20	N/A		
	RB <sub>end</sub>	N/A	> 48	N/A	N/A	N/A	> 42	N/A	N/A	> 35	
	A-MPR [dB]	≤ 1	≤ 1	≤ 1	≤ 5	≤ 5	≤ 1	≤ 10	≤ 7	≤ 11	
15	Fc [MHz]	1972.5 < Fc ≤ 1987.5						Fc > 1987.5			
	RB <sub>start</sub>	0 - 4		5 - 30		31 - 62		63 - 74		0 - 74	
	L <sub>CRB</sub> [RBs]	≥ 15		≥ 45		N/A		N/A		0 - 74	
	RB <sub>end</sub>	N/A		N/A		> 71		N/A		N/A	
	A-MPR [dB]	≤ 4		≤ 3		≤ 1		≤ 1		≤ 13	
20	Fc [MHz]	1970 < Fc ≤ 1990						Fc > 1990			
	RB <sub>start</sub>	0 - 13		14 - 40		41 - 99		0 - 99			
	L <sub>CRB</sub> [RBs]	N/A		≥ 32		N/A		0 - 99			
	RB <sub>end</sub>	N/A		N/A		> 72		N/A			

	A-MPR [dB]	$\leq 11$	$\leq 11$	$\leq 13$	$\leq 13$
--	------------	-----------	-----------	-----------	-----------

Table 6.2.4-21: A-MPR for "NS\_26"

Bandwidth (MHz)	RBstart	L_crb	A-MPR
10	0 - 10	$\geq 1$	$\leq 1$
15	0 - 17	$\geq 1$	$\leq 1$

Table 6.2.4-22: A-MPR for "NS\_27"

Parameters				
Channel bandwidth [MHz]	RB <sub>start</sub>	RB <sub>end</sub>	L <sub>CRB</sub>	A-MPR
15	0 – 6	68 – 74	$\leq 15$	$\leq 4$ dB
	$\geq 0$		$\geq 60$	$\leq 2$ dB
	0 – 12	87 – 99	$\leq 20$	$\leq 4$ dB
13 – 15	$\leq 3$		$\leq 1$ dB	
$\geq 0$			$\geq 60$	$\leq 3$ dB

Table 6.2.4-23: A-MPR for "NS\_28"

Parameters			
Channel Bandwidth [MHz]	Carrier centre frequency (F <sub>C</sub> ) [MHz]	Uplink resource allocation	A-MPR [dB]
20	5160 $\leq$ F <sub>C</sub> < 5179.8 5320.2 < F <sub>C</sub> $\leq$ 5340 5480 $\leq$ F <sub>C</sub> < 5499.8	L = 10 (RIV = 19)	9
		Any other RIV	8
		L = 10 (RIV = 19)	9
	5680.2 < F <sub>C</sub> $\leq$ 5715	Any other RIV	8
		L = 10 (RIV = 19)	2
		Any other RIV	2

NOTE 1: The carrier centre frequencies and corresponding EARFCN allowed for operation in Band 46 are specified in [12]. The uplink resource allocation is defined in Clause 8.1.4 of [6].

Table 6.2.4-24: A-MPR for "NS\_29"

Parameters			
Channel Bandwidth [MHz]	Carrier centre frequency (F <sub>C</sub> ) [MHz]	Uplink resource allocation	A-MPR [dB]
20	5179.8 $\leq$ F <sub>C</sub> $\leq$ 5320.2 5499.8 $\leq$ F <sub>C</sub> $\leq$ 5700.2	L = 10 (RIV = 19)	2
		Any other RIV	1

NOTE 1: The carrier centre frequencies and corresponding EARFCN allowed for operation in Band 46 are specified in [12]. The uplink resource allocation is defined in Clause 8.1.4 of [6].

Table 6.2.4-25: A-MPR for "NS\_30"

Channel Bandwidth [MHz]	Parameters		
	Carrier centre frequency (F <sub>c</sub> ) [MHz]	Uplink resource allocation	A-MPR [dB]
20	5160 ≤ F <sub>c</sub> < 5179.8 5320.2 < F <sub>c</sub> ≤ 5340	L = 10 (RIV = 19)	15
		Any other RIV	16
	5179.8 ≤ F <sub>c</sub> < 5199.8 5300.2 < F <sub>c</sub> ≤ 5320.2	L = 10 (RIV = 19)	3
		Any other RIV	3
	5480 ≤ F <sub>c</sub> < 5499.8	L = 10 (RIV = 19)	11
		Any other RIV	11
	5680.2 < F <sub>c</sub> ≤ 5715	L = 10 (RIV = 19)	6
		Any other RIV	6
	5199.8 ≤ F <sub>c</sub> ≤ 5300.2 5499.8 ≤ F <sub>c</sub> ≤ 5680.2	L = 10 (RIV = 19)	1
		Any other RIV	N/A

NOTE 1: The carrier centre frequencies and corresponding EARFCN allowed for operation in Band 46 are specified in [12]. The uplink resource allocation is defined in Clause 8.1.4 of [6]. The uplink resource allocation is defined in Clause 8.1.4 of [6].

Table 6.2.4-26: A-MPR for "NS\_31"

Channel Bandwidth [MHz]	Carrier centre frequency (F <sub>c</sub> ) [MHz]	Uplink resource allocation	A-MPR [dB]
20	5239.8 ≤ F <sub>c</sub> ≤ 5240.2	L = 10 (RIV = 19)	7
		Any other RIV	7
	5160 ≤ F <sub>c</sub> < 5179.8 5260 ≤ F <sub>c</sub> < 5279.8 5320.2 < F <sub>c</sub> ≤ 5340 5480 ≤ F <sub>c</sub> < 5499.8	L = 10 (RIV = 19)	6
		Any other RIV	6
		L = 10 (RIV = 19)	6
	5680.2 < F <sub>c</sub> ≤ 5715 5805.2 < F <sub>c</sub> ≤ 5840	L = 10 (RIV = 19)	6
		Any other RIV	6
	5735 ≤ F <sub>c</sub> < 5764.8	L = 10 (RIV = 19)	6
		Any other RIV	6
	5179.8 ≤ F <sub>c</sub> ≤ 5220.2 5279.8 ≤ F <sub>c</sub> ≤ 5320.2 5499.8 ≤ F <sub>c</sub> ≤ 5680.2 5764.8 ≤ F <sub>c</sub> ≤ 5805.2	L = 10 (RIV = 19)	2
Any other RIV		1	

NOTE 1: The carrier centre frequencies and corresponding EARFCN allowed for operation in Band 46 are specified in [12]. The uplink resource allocation is defined in Clause 8.1.4 of [6].

Table 6.2.4-27: A-MPR for "NS\_36"

Channel Bandwidth [MHz]	Parameters				
	F <sub>c</sub> [MHz]	700.5 ≤ F <sub>c</sub> < 705.5			
5 MHz	RB <sub>start</sub>	0		1-4	
	LCRB [RBs]	1	≥ 15	≥ 15	24
	A-MPR [dB]	≤ 2	≤ 4	≤ 1	≤ 3
	F <sub>c</sub> [MHz]	703 ≤ F <sub>c</sub> < 708			
10 MHz	RB <sub>start</sub>	0 - 8	9 - 12	13 - 39	40 - 43
	LCRB [RBs]	> 0	> 12	> 16	> 0
	A-MPR [dB]	≤ 10	≤ 8	≤ 6	≤ 6
	F <sub>c</sub> [MHz]	F <sub>c</sub> = 705.5			
15 MHz	RB <sub>start</sub>	0 - 16	17 - 23	24 - 56	57 - 60

	L <sub>CRB</sub> [RBs]	> 0	> 12	> 20	< 6
	A-MPR [dB]	≤ 10	≤ 9	≤ 7	≤ 6

NOTE 1: RB<sub>start</sub> indicates the lowest RB index of transmitted resource blocks  
 NOTE 2: L<sub>CRB</sub> is the length of a contiguous resource block allocation  
 NOTE 3: For intra-subframe frequency hopping between two regions, notes 1 and 2 apply on a per slot basis. For intra-slot or intra-subslot frequency hopping between two regions, notes 1 and 2 apply on a per T<sub>no\_hopping</sub> basis.  
 NOTE 4: For intra-subframe frequency hopping between two regions, the larger A-MPR value of the two regions may be applied for both slots in the subframe. For intra-slot frequency hopping between two regions, the larger A-MPR value may be applied for the slot. For intra-subslot frequency hopping between two regions, the larger A-MPR value may be applied for the subslot.

Table 6.2.4-28: A-MPR for "NS\_38"

Channel Bandwidth [MHz]	Carrier centre frequency (F <sub>c</sub> ) [MHz]	Parameters	Region A	Region B	Region C	Region D	Region E					
1.4	1427.7 ≤ F <sub>c</sub> < 1429.1	A-MPR [dB]	≤ [16]									
3	1428.5 ≤ F <sub>c</sub> < 1431.5	RB <sub>start</sub>	0		1-2		3-6					
		L <sub>CRB</sub> [RBs]	1	≥2	2	≥3	5-7	≥8				
		A-MPR [dB]	≤ 11	≤ 16	≤ 9	≤ 15	≤ 12	≤ 14				
5	1429.5 ≤ F <sub>c</sub> < 1434.5	RB <sub>start</sub>	0-1		2-4		5-7		8-10			
		L <sub>CRB</sub> [RBs]	2	≥3	4-6	≥7	8-10	≥11	12-14	≥15		
		A-MPR [dB]	≤ 12	≤ 16	≤ 13	≤ 16	≤ 12	≤ 15	≤ 10	≤ 12		
10	1432 ≤ F <sub>c</sub> < 1442	RB <sub>start</sub>	0		1-4		5-9		10-14		15-21	
		L <sub>CRB</sub> [RBs]	3-4	≥5	5-8	≥9	9-16	≥17	15-23	≥24	24-29	≥30
		A-MPR [dB]	≤ 13	≤ 16	≤ 13	≤ 16	≤ 13	≤ 16	≤ 11	≤ 14	≤ 11	≤ 13
15	1434.5 ≤ F <sub>c</sub> < 1447.5	RB <sub>start</sub>	0-1		2-7		8-17		18-23		24-30	
		L <sub>CRB</sub> [RBs]	5-10	≥11	8-12	≥13	15-25	≥26	26-40	≥41	≥36	
		A-MPR [dB]	≤ 14	≤ 16	≤ 13	≤ 16	≤ 13	≤ 16	≤ 12	≤ 14	≤ 12	
20	1437 ≤ F <sub>c</sub> < 1450	RB <sub>start</sub>	0-4		5-9		10-19		20-29		30-40	
		L <sub>CRB</sub> [RBs]	6-10	≥11	11-20	≥21	17-32	≥33	28-45	≥46	41-54	≥55
		A-MPR [dB]	≤ 13	≤ 16	≤ 13	≤ 16	≤ 13	≤ 16	≤ 12	≤ 14	≤ 11	≤ 13

Table 6.2.4-29: A-MPR for "NS\_39"

Channel Bandwidth [MHz]	Carrier centre frequency (F <sub>c</sub> ) [MHz]	Parameters	Region A	Region B	Region C		
10	1462 < F <sub>c</sub> ≤ 1465	RB <sub>start</sub>	43-50				
		L <sub>CRB</sub> [RBs]	≤ 3	> 3 and ≤ 25	≥ 32		
		A-MPR [dB]	≤ 4	≤ 3	≤ 3		
15	1456.3 < F <sub>c</sub> ≤ 1462.5	RB <sub>start</sub>	56-75		64-75	60-75	
		L <sub>CRB</sub> [RBs]	≥ 36		≥ 13 and ≤ 35	≥ 5 and ≤ 12	< 5
		A-MPR [dB]	≤ 3		≤ 2	≤ 3	≤ 4
20	1450.8 < F <sub>c</sub> ≤ 1460	RB <sub>start</sub>	71-100		>76		
		L <sub>CRB</sub> [RBs]	≥ 36		≥ 7 and ≤ 35	< 7	
		A-MPR [dB]	≤ 3		≤ 3	≤ 4	

Table 6.2.4-30a: A-MPR for "NS\_40"

Channel bandwidth confined to 1427-1432MHz (B51)										
Channel bandwidth [MHz]	Carrier centre frequency (F <sub>c</sub> ) [MHz]	Parameters	Region A		Region B		Region C		Region D	
3MHz	1428.5 MHz ≤ F <sub>c</sub> ≤ 1430.5 MHz	RB <sub>start</sub>	0		1–2		3–6			
		LCRB [RBs]	1	≥2	2	≥3	5-6	≥8		
		A-MPR [dB]	≤ 11	≤ 16	≤ 9	≤ 15	≤ 12	≤ 14		
5MHz	1429.5 MHz ≤ F <sub>c</sub> ≤ 1432 MHz	RB <sub>start</sub>	0 - 1		2 – 4		5 – 7		8 – 10	
		LCRB [RBs]	2	≥3	4-6	≥ 7	8-10	≥11	12	≥15
		A-MPR [dB]	≤ 12	≤ 16	≤ 13	≤ 16	≤ 12	≤ 15	≤ 10	≤ 12

Table 6.2.4-30b: A-MPR for "NS\_40"

Channel bandwidth confined to 1429-1432MHz (B51)			
Channel bandwidth [MHz]	Carrier centre frequency (F <sub>c</sub> ) [MHz]	Parameters	Region A
3MHz	1430.5 MHz < F <sub>c</sub> ≤ 1432 MHz	RB <sub>start</sub>	0
		LCRB [RBs]	12
		A-MPR [dB]	≤ 9

Table 6.2.4-31: A-MPR for "NS\_41"

Channel bandwidth confined to 1432-1452MHz (B50)									
Channel bandwidth [MHz]	Parameters	Region A	Region B	Region C	Region D	Region E	Region F	Region G	Region H
3MHz	RB <sub>start</sub>								
	LCRB [RBs]								
	A-MPR [dB]								
5MHz	RB <sub>start</sub>								
	LCRB [RBs]								
	A-MPR [dB]								
10MHz	RB <sub>start</sub>	0 – 4	5 – 6						
	LCRB [RBs]	≥ 36	≥ 40						
	A-MPR [dB]	≤ 11	≤ 10						
15MHz	RB <sub>start</sub>	0-1	02-06	07-11	12-13	14-15			
	LCRB [RBs]	≥ 36	≥ 40	≥ 48	26-40	≥ 54			
	A-MPR [dB]	≤ 12	≤ 12	≤ 11	≤ 10	≤ 10			
20 MHz	RB <sub>start</sub>	0	1 – 4	5-6	7-9	10 – 11	12 – 16	17 – 20	21 – 26
	LCRB [RBs]	≥ 36	45-53 ≥ 54	≥ 33	≥ 48	≥ 50	≥ 60	≥ 64	≥ 64
	A-MPR [dB]	≤ 12	≤ 11 ≤ 12	≤ 12	≤ 12	≤ 12	≤ 12	≤ 11	≤ 10

Table 6.2.4-32: A-MPR for "NS\_42"

Channel bandwidth [MHz]	Carrier centre frequency (F <sub>c</sub> ) [MHz]	Parameters	Region A		Region B		Region C		Region D		Region E	
3MHz	1512.5 MHz ≤ F <sub>c</sub> ≤ 1515.5 MHz	RB <sub>start</sub>	0 – 3		4 – 7		8-10		11-14			
		L <sub>CRB</sub> [RBs]	8-11	≥ 12	≥ 8		≥ 3		≥ 1			
		A-MPR [dB]	≤ 3	≤ 5	≤ 6		≤ 3		≤ 3			
3MHz	1511 MHz ≤ F <sub>c</sub> < 1512.5 MHz	RB <sub>start</sub>	0									
		L <sub>CRB</sub> [RBs]	12									
		A-MPR [dB]	≤ 1									
5MHz	1507 MHz ≤ F <sub>c</sub> ≤ 1514.5 MHz	RB <sub>start</sub>	0 – 5		6 – 11		12-16		17-24			
		L <sub>CRB</sub> [RBs]	12-16	≥ 17	9-12	≥ 13	5-8	≥ 9	1-6	≥ 7		
		A-MPR [dB]	≤ 5	≤ 9	≤ 6	≤ 10	≤ 4	≤ 9	≤ 4	≤ 6		
10MHz	1502 MHz ≤ F <sub>c</sub> ≤ 1512 MHz	RB <sub>start</sub>	0 – 22		23 – 27		28-35		36-49			
		L <sub>CRB</sub> [RBs]	≥ 20		15-19	≥ 20	3-14	≥ 15	1-9	≥ 10		
		A-MPR [dB]	≤ 4		≤ 4	≤ 9	≤ 4	≤ 10	≤ 3	≤ 8		
10MHz	1497 MHz ≤ F <sub>c</sub> < 1502 MHz	RB <sub>start</sub>	0 – 5									
		L <sub>CRB</sub> [RBs]	40									
		A-MPR [dB]	≤ 1									
15MHz	1497 MHz F <sub>c</sub> ≤ 1509.5 MHz	RB <sub>start</sub>	0 – 22		23 – 48		49-60		61-74			
		L <sub>CRB</sub> [RBs]	≥ 36		9-23	≥ 24	1-14	≥ 15	≥ 1			
		A-MPR [dB]	≤ 4		≤ 3	≤ 5	≤ 3	≤ 9	≤ 4			
20 MHz	1492 MHz ≤ F <sub>c</sub> ≤ 1507 MHz	RB <sub>start</sub>	0 – 20		21 – 40		41 – 60		61 – 80		81 – 99	
		L <sub>CRB</sub> [RBs]	24-47	≥ 48	≥ 40		15-29	≥ 30	1-17	≥ 18	1-14	≥ 15
		A-MPR [dB]	≤ 2	≤ 4	≤ 3		≤ 2	≤ 4	≤ 3	≤ 4	≤ 3	≤ 6



Table 6.2.4-32a: Void

Table 6.2.4-32b: Void

Table 6.2.4-33: A-MPR for “NS\_43”

Parameters			
Channel bandwidth (MHz)	Carrier centre frequency (F <sub>c</sub> ) (MHz)	Uplink resource allocation	A-MPR (dB)
20	3580 ≤ F <sub>c</sub> ≤ 3670	L = 10 (RIV = 19)	[1]
		Any other RIV	[2]
	3560 ≤ F <sub>c</sub> < 3580 3670 < F <sub>c</sub> ≤ 3690	L = 10 (RIV = 19)	[4]
		Any other RIV	[4]

NOTE 1: The uplink resource allocation is defined in Clause 8.1.4 of TS 36.213 [6].

Table 6.2.4-34: A-MPR requirements for “NS\_44” for Power Class 2 UE

Channel bandwidth [MHz]	Parameters			
	F <sub>c</sub> [MHz]	RB <sub>start</sub>	L <sub>CRB</sub> [RBs]	A-MPR [dB]
10	≥2605	0 – 5	38-49	<2605
	<2605	≥ 45	< 13	0 - 49
	N/A	N/A	NA	> 0
	N/A	N/A	NA	N/A
	≤ 1	≤ 1	≤ 1	0
15	≥2597.5	0 – 18	19-30	<2597.5
	<2597.5	≥ 45&<56	54-74	0 - 74
	N/A	≥ 63	< 17	> 0
	N/A	N/A	NA	N/A
	≤ 1	≤ 1	≤ 1	0
20	≥2590	0 – 31	32-55	<2590
	<2590	N/A	70-99	0 - 99
	N/A	≥ 45&<68	< 19	> 0
	N/A	≥ 76	NA	N/A
	≤ 2	≤ 1	≤ 1	0

For PRACH, PUCCH and SRS transmissions, the allowed A-MPR is according to that specified for PUSCH QPSK modulation for the corresponding transmission bandwidth.

For each TTI pattern, the A-MPR shall be evaluated per T<sub>eval</sub> period as specified in table 6.2.4-35 and given by the maximum value taken over the transmission(s) within that period; the maximum A-MPR over the T<sub>REF</sub> is then applied for T<sub>REF</sub>.

Table 6.2.4-35: A-MPR evaluation period

TTI pattern	T <sub>REF</sub>	T <sub>eval</sub>
Subframe	1 subframe	1 slot
Slot	7 OS	Min(T <sub>no_hopping</sub> , 7OS)
Sublot	2 OS, 3OS	Min(T <sub>no_hopping</sub> , 2OS/3OS)

For the UE maximum output power modified by A-MPR, the power limits specified in subclause 6.2.5 apply.

## 6.2.4A UE maximum output power with additional requirements for CA

Additional ACLR, spectrum emission and spurious emission requirements for carrier aggregation can be signalled by the network to indicate that the UE shall also meet additional requirements in a specific deployment scenario. To meet these additional requirements, Additional Maximum Power Reduction (A-MPR) is allowed for the CA Power Class as specified in Table 6.2.2A-1.

If for intra-band carrier aggregation the UE is configured for transmissions on a single serving cell, then subclauses 6.2.3 and 6.2.4 apply with the Network Signalling value indicated by the field *additionalSpectrumEmission*.

For intra-band contiguous aggregation with the UE configured for transmissions on two serving cells, the maximum output power reduction specified in Table 6.2.4A-1 is allowed for all serving cells of the applicable uplink CA configurations according to the CA network signalling value indicated by the field *additionalSpectrumEmissionSCell-r10*. Then clause 6.2.3A does not apply, i.e. the carrier aggregation MPR = 0dB, unless the value indicated is CA\_NS\_09 or CA\_NS\_31. For uplink 64 QAM and 256 QAM, the applied maximum output power reduction is obtained by taking the maximum value of MPR requirements specified in Table 6.2.3A-1 and A-MPR requirements specified in Table 6.2.4A-1.

**Table 6.2.4A-1: Additional Maximum Power Reduction (A-MPR) for intra-band contiguous CA**

CA Network Signalling value	Requirements (subclause)	Uplink CA Configuration	A-MPR [dB] (subclause)
CA_NS_01	6.6.3.3A.1	CA_1C	6.2.4A.1
CA_NS_02	6.6.3.3A.2	CA_1C	6.2.4A.2
CA_NS_03	6.6.3.3A.3	CA_1C	6.2.4A.3
CA_NS_04	6.6.2.2A.1, 6.6.3.3A.8	CA_41C, CA_41D	6.2.4A.4
CA_NS_05	6.6.3.3A.4	CA_38C	6.2.4A.5
CA_NS_06	6.6.3.3A.5	CA_7C	6.2.4A.6
CA_NS_07	6.6.3.3A.6	CA_39C	6.2.4A.7
CA_NS_08	6.6.3.3A.7	CA_42C	6.2.4A.8
CA_NS_09	6.6.2.2A.2	CA_66B	N/A
	6.6.2.2A.3	CA_66C	N/A
CA_NS_10	6.6.2.2A.4 6.6.3.3A.10	CA_48B, CA_48C	6.2.4A.10
...			
CA_NS_31	NOTE 1	Table 5.6A.1-1 (NOTE 1)	N/A
CA_NS_32		Reserved	
NOTE 1: Applicable for uplink CA configurations listed in Table 5.6A.1-1 for which none of the additional requirements in subclauses 6.6.2.2A or 6.6.3.3A apply.			
NOTE 2: The index of the sequence CA_NS corresponds to the value of <i>additionalSpectrumEmissionSCell-r10</i> .			

If for intra-band non-contiguous carrier aggregation the UE is configured for transmissions on a single serving cell, then subclauses 6.2.3 and 6.2.4 apply with the Network Signalling value indicated by the field *additionalSpectrumEmission*.

For intra-band non-contiguous carrier aggregation with the UE configured for transmissions on two serving cells, the maximum output power reduction specified in Table 6.2.4A-2 is allowed for all serving cells of the applicable uplink CA configurations according to the CA network signalling value indicated by the field *additionalSpectrumEmissionSCell-r10*. MPR as specified in subclause 6.2.3A is not allowed in addition, unless A-MPR is N/A.

**Table 6.2.4A-2: Additional Maximum Power Reduction (A-MPR) for intra-band non-contiguous CA**

CA Network Signalling value	Additional requirements for sub-blocks in order of increasing uplink carrier frequency		Uplink CA Configuration	A-MPR for sub-blocks in order of increasing uplink carrier frequency
	Requirements (subclause)	Requirements (subclause)		A-MPR [dB] (subclause)
CA_NC_NS_01	6.6.2.2.1 (NS_03)	6.6.2.2.1 (NS_03)	CA_4A-4A	N/A
...				
CA_NC_NS_31	NOTE 1	NOTE 1	Table 5.6A.1-3 (NOTE 1)	N/A
CA_NC_NS_32	Reserved			
NOTE 1: Applicable for uplink CA configurations listed in Table 5.6A.1-3 for which the additional requirements in subclause 6.6.2.1.1 (indicated by NS_01) applies in each sub-block.				
NOTE 2: The index of the sequence CA_NC_NS corresponds to the value of <i>additionalSpectrumEmissionSCell-r10</i> .				

If for inter-band carrier aggregation the UE is configured for transmissions on a single serving cell, then subclauses 6.2.3 and 6.2.4 apply with the Network Signaling value indicated by the field *additionalSpectrumEmission*.

For inter-band carrier aggregation with the UE configured for transmissions on two serving cells the maximum output power reduction specified in Table 6.2.4-1 is allowed for each serving cell of the applicable uplink CA configuration according to the Network Signaling value indicated by the field *additionalSpectrumEmission* for the PCC and the CA network signalling value indicated by the field *additionalSpectrumEmissionSCell-r10* for the SCC. The value of *additionalSpectrumEmissionSCell-r10* is equal to that of *additionalSpectrumEmission* configured on the SCC. MPR as specified in subclause 6.2.3A is allowed in addition.

For PUCCH and SRS transmissions, the allowed A-MPR is according to that specified for PUSCH QPSK modulation for the corresponding transmission bandwidth.

For intra-band carrier aggregation, the A-MPR shall be evaluated per  $T_{eval}$  period as specified in table 6.2.4A-3 and given by the maximum value taken over the transmission(s) on all component carriers within that period; the maximum A-MPR over  $T_{REF}$  is then applied for the entire  $T_{REF}$ .

**Table 6.2.4A-3: A-MPR evaluation  $T_{eval}$  period**

TTI pattern	$T_{REF}$	$T_{eval}$
Subframe	1 subframe	1 slot
Slot	7 OS	$\text{Min}(T_{no\_hopping}, 7OS)$
Sublot	2 OS, 3OS	$\text{Min}(T_{no\_hopping}, 2OS/3OS)$

For combinations of intra-band and inter-band carrier aggregation with the UE configured for transmission on three serving cells (up to two contiguously aggregated carriers per band), the maximum output power reduction is specified as follows. For the band supporting one serving cell the maximum output power reduction specified in Table 6.2.4-1 is allowed according to the Network Signaling value indicated by the field *additionalSpectrumEmission* for the PCC and the CA network signalling value indicated by the field *additionalSpectrumEmissionSCell-r10* for the SCC. The value of *additionalSpectrumEmissionSCell-r10* is equal to that of *additionalSpectrumEmission* configured on the SCC. MPR as specified in subclause 6.2.3A is allowed in addition. For the band supporting intra-band contiguous aggregation with the UE configured for transmissions on two serving cells, the maximum output power reduction specified in Table 6.2.4A-1 is allowed for all serving cells of the applicable uplink CA configurations according to the CA network signalling value indicated by the field *additionalSpectrumEmissionSCell-r10*. Then clause 6.2.3A does not apply, i.e. the carrier aggregation MPR = 0dB, unless the value indicated is CA\_NS\_31. For uplink 64 QAM and 256 QAM, the applied maximum output power reduction is obtained by taking the maximum value of MPR requirements specified in Table 6.2.3A-1 and A-MPR requirements specified in Table 6.2.4A-1.

For the UE maximum output power modified by A-MPR specified in table 6.2.4A-1, the power limits specified in subclause 6.2.5A apply.

## 6.2.4A.1 A-MPR for CA\_NS\_01 for CA\_1C

If the UE is configured to CA\_1C and it receives IE CA\_NS\_01 the allowed maximum output power reduction applied to transmissions on the PCC and the SCC for contiguously aggregated signals is specified in table 6.2.4A.1-1.

Table 6.2.4A.1-1: Contiguous allocation A-MPR for CA\_NS\_01

CA_1C: CA_NS_01	RB <sub>start</sub>	L <sub>CRB</sub> [RBs]	RB <sub>start</sub> + L <sub>CRB</sub> [RBs]	A-MPR for QPSK, 16 QAM, 64 QAM and 256 QAM [dB]
100 RB / 100 RB	0 – 23 and 176 – 199	> 0	N/A	≤ 12.0
	24 – 105	> 64	N/A	≤ 6.0
	106 – 175	N/A	> 175	≤ 5.0
75 RB / 75 RB	0 – 6 and 143 – 149	0 < L <sub>CRB</sub> ≤ 10	N/A	≤ 11.0
		> 10	N/A	≤ 6.0
	7 – 90	> 44	N/A	≤ 5.0
	91 – 142	N/A	> 142	≤ 2.0

NOTE 1: RB<sub>start</sub> indicates the lowest RB index of transmitted resource blocks

NOTE 2: L<sub>CRB</sub> is the length of a contiguous resource block allocation

NOTE 3: For intra-subframe frequency hopping which intersects regions, notes 1 and 2 apply on a per slot basis. For intra-slot or intra-subslot frequency hopping which intersects regions, notes 1 and 2 apply on a per T<sub>no\_hopping</sub> basis.

NOTE 4: For intra-subframe frequency hopping which intersects regions, the larger A-MPR value may be applied for both slots in the subframe. For intra-slot frequency hopping which intersects regions, the larger A-MPR value may be applied for the slot. For intra-subslot frequency hopping which intersects regions, the larger A-MPR value may be applied for the subslot.

If the UE is configured to CA\_1C and it receives IE CA\_NS\_01 the allowed maximum output power reduction applied to transmissions on the PCell and the SCell with non-contiguous resource allocation is defined as follows

$$A\text{-MPR} = \text{CEIL} \{M_A, 0.5\}$$

Where M<sub>A</sub> is defined as follows

$$M_A = \begin{cases} -22.5 A + 17 & ; 0 \leq A < 0.20 \\ -11.0 A + 14.7 & ; 0.20 \leq A < 0.70 \\ -1.7 A + 8.2 & ; 0.70 \leq A \leq 1 \end{cases}$$

Where A = N<sub>RB\_alloc</sub> / N<sub>RB\_agg</sub>.

## 6.2.4A.2 A-MPR for CA\_NS\_02 for CA\_1C

If the UE is configured to CA\_1C and it receives IE CA\_NS\_02 the allowed maximum output power reduction applied to transmission on the PCC and the SCC for contiguously aggregated signals is specified in Table 6.2.4A.2-1.

Table 6.2.4A.2-1: Contiguous allocation A-MPR for CA\_NS\_02

CA_1C: CA_NS_02	RB <sub>end</sub>	L <sub>CRB</sub> [RBs]	A-MPR for QPSK, 16 QAM, 64 QAM and 256 QAM [dB]
100 RB / 100 RB	0 – 20	> 0	≤ 4 dB
	21 – 46	> 0	≤ 3 dB
	47 – 99	> RB <sub>end</sub> - 20	≤ 3 dB
	100 – 184	> 75	≤ 6 dB
	185 – 199	> 0	≤ 10 dB
75 RB / 75 RB	0 – 48	> 0	≤ 2 dB
	49 – 80	> RB <sub>end</sub> - 20	≤ 3 dB
	81 – 129	> 60	≤ 5 dB
	130 – 149	> 84	≤ 6 dB
	130 – 149	1 – 84	≤ 2 dB

If the UE is configured to CA\_1C and it receives IE CA\_NS\_02 the allowed maximum output power reduction applied to transmissions on the PCell and the SCell with non-contiguous resource allocation is defined as follows:

$$A\text{-MPR} = \text{CEIL} \{M_A, 0.5\}$$

Where  $M_A$  is defined as follows

$$M_A = \begin{cases} -22.5 A + 17 & ; 0 \leq A < 0.20 \\ -11.0 A + 14.7 & ; 0.20 \leq A < 0.70 \\ -1.7 A + 8.2 & ; 0.70 \leq A \leq 1 \end{cases}$$

Where  $A = N_{RB\_alloc} / N_{RB\_agg}$ .

### 6.2.4A.3 A-MPR for CA\_NS\_03 for CA\_1C

If the UE is configured to CA\_1C and it receives IE CA\_NS\_03 the allowed maximum output power reduction applied to transmission on the PCC and the SCC for contiguously aggregated signals is specified in Table 6.2.4A.3-1.

Table 6.2.4A.3-1: Contiguous allocation A-MPR for CA\_NS\_03

CA_1C: CA_NS_03	RB <sub>end</sub>	L <sub>CRB</sub> [RBs]	A-MPR for QPSK, 16 QAM, 64 QAM and 256 QAM [dB]
100 RB / 100 RB	0 – 26	> 0	≤ 10 dB
	27 – 63	≥ RB <sub>end</sub> - 27	≤ 6 dB
	27 – 63	< RB <sub>end</sub> - 27	≤ 1 dB
	64 – 100	> RB <sub>end</sub> - 20	≤ 4 dB
	101 – 171	> 68	≤ 7 dB
	172 – 199	> 0	≤ 10 dB
75 RB / 75 RB	0 – 20	> 0	≤ 10 dB
	21 – 45	> 0	≤ 4 dB
	46 – 75	> RB <sub>end</sub> - 13	≤ 2 dB
	76 – 95	> 45	≤ 5 dB
	96 – 149	> 43	≤ 8 dB
	120 – 149	1 - 43	≤ 6 dB

If the UE is configured to CA\_1C and it receives IE CA\_NS\_03 the allowed maximum output power reduction applied to transmissions on the PCell and the SCell with non-contiguous resource allocation is defined as follows:

$$A\text{-MPR} = \text{CEIL} \{M_A, 0.5\}$$

Where  $M_A$  is defined as follows

$$M_A = -23.33A + 17.5 \quad ; 0 \leq A < 0.15$$

$$-7.65A + 15.15 \quad ; 0.15 \leq A \leq 1$$

Where  $A = N_{RB\_alloc} / N_{RB\_agg}$ .

#### 6.2.4A.4 A-MPR for CA\_NS\_04

If the UE is configured to CA\_41C or any uplink inter-band CA configuration containing CA\_41C and it receives IE CA\_NS\_04 the allowed maximum output power reduction applied to transmission on two component carriers for contiguously aggregated signals is specified in Table 6.2.4A.4-1 and Table 6.2.4A.4-1A for UE power class 3 and in Table 6.2.4A.4-2 for UE power class 2.

**Table 6.2.4A.4-1: Contiguous Allocation A-MPR for CA\_NS\_04 (power class 3), Bandwidth Class C**

CA Bandwidth Class C	RB <sub>Start</sub>	L <sub>CRB</sub> [RBs]	RB <sub>start</sub> + L <sub>CRB</sub> [RBs]	A-MPR for QPSK [dB]	A-MPR for 16 QAM, 64 QAM and 256 QAM [dB]
25 RB / 100 RB	0 – 34 and 90 – 124	>0	N/A	≤3dB	≤3.5dB
	35 – 89	N/A	>90	≤1dB	≤2.5dB
50RB / 100 RB	0 – 44 and 105 – 149	>0	N/A	≤4dB	≤4dB
	45 – 104	N/A	>105	≤3dB	≤4dB
75 RB / 75 RB	0 – 44 and 105 – 149	>0	N/A	≤4dB	≤4dB
	45 – 104	N/A	>105	≤4dB	≤4dB
100 RB / 75 RB	0 – 49 and 125 – 174	>0	N/A	≤4dB	≤4dB
	50 - 124	N/A	>125	≤3dB	≤4dB
100 RB / 100 RB	0 – 59 and 140 – 199	>0	N/A	≤3dB	≤4dB
	60– 139	N/A	>140	≤4dB	≤4dB

NOTE 1: RB<sub>start</sub> indicates the lowest RB index of transmitted resource blocks  
NOTE 2: L<sub>CRB</sub> is the length of a contiguous resource block allocation  
NOTE 3: For intra-subframe frequency hopping which intersects regions, notes 1 and 2 apply on a per slot basis. For intra-slot or intra-subslot frequency hopping which intersects regions, notes 1 and 2 apply on a per T<sub>no\_hopping</sub> basis..  
NOTE 4: For intra-subframe frequency hopping which intersects regions, the larger A-MPR value may be applied for both slots in the subframe. For intra-slot frequency hopping which intersects regions, the larger A-MPR value may be applied for the slot. For intra-subslot frequency hopping which intersects regions, the larger A-MPR value may be applied for the subslot.

**Table 6.2.4A.4-1A: Contiguous Allocation A-MPR for CA\_NS\_04 (power class 3), Bandwidth Class D**

CA Bandwidth Class D	RB <sub>Start</sub>	L <sub>CRB</sub> [RBs]	RB <sub>start</sub> + L <sub>CRB</sub> [RBs]	A-MPR for QPSK [dB]	A-MPR for 16 QAM, 64 QAM and 256 QAM [dB]
50 RB / 75 RB / 100 RB	0 – 64 and 161 – 224	>0	N/A	≤4dB	≤4.5dB
	65 – 160	N/A	>161	≤3dB	≤3.5dB
50 RB / 100 RB / 100 RB	0 – 72 and 178 – 249	>0	N/A	≤4dB	≤4.5dB
	73 – 177	N/A	>178	≤3dB	≤3.5dB
75 RB / 75 RB / 100 RB	0 – 72 and 178 – 249	>0	N/A	≤4dB	≤4.5dB
	73 – 177	N/A	>178	≤3dB	≤3.5dB
75 RB / 100 RB / 100 RB	0 – 78 and 197 – 274	>0	N/A	≤3.5dB	≤4dB
	79 - 196	N/A	>197	≤2.5dB	≤3dB
100 RB / 100 RB / 100 RB	0 – 96 and 204 – 300	>0	N/A	≤4dB	≤4dB
	97– 203	N/A	>204	≤2.5dB	≤3dB

NOTE 1:  $RB_{start}$  indicates the lowest RB index of transmitted resource blocks  
 NOTE 2:  $L_{CRB}$  is the length of a contiguous resource block allocation  
 NOTE 3: For intra-subframe frequency hopping which intersects regions, notes 1 and 2 apply on a per slot basis. For intra-slot or intra-subslot frequency hopping which intersects regions, notes 1 and 2 apply on a per  $T_{no\_hopping}$  basis..  
 NOTE 4: For intra-subframe frequency hopping which intersects regions, the larger A-MPR value may be applied for both slots in the subframe. For intra-slot frequency hopping which intersects regions, the larger A-MPR value may be applied for the slot. For intra-subslot frequency hopping which intersects regions, the larger A-MPR value may be applied for the subslot.

Table 6.2.4A.4-2: Contiguous Allocation A-MPR for CA\_NS\_04 (power class 2)

CA Bandwidth Class C	Lower edge cutoff frequency [MHz] <sup>5</sup>	$RB_{start}$	$L_{CRB}$ [RBs]	$RB_{start} + L_{CRB}$ [RBs]	A-MPR per modulation [dB]			
					QPSK	16QAM	64QAM	256QAM
25 RB / 100 RB	2513.5	0 – 42	>0	N/A	≤5	≤5	≤5	FFS
		43 – 81	N/A	>82	≤1	≤1.5	≤1.5	FFS
		82 – 124	>0	N/A	≤1	≤1.5	≤1.5	FFS
50 RB / 100 RB	2518.4	0 – 52	>0	N/A	≤5	≤5	≤5	FFS
		53 – 94	N/A	>95	≤1	≤1.5	≤1.5	FFS
		95 – 149	>0	N/A	≤1	≤1.5	≤1.5	FFS
75 RB / 75 RB	2519.0	0 – 54	>0	N/A	≤5	≤5	≤5	FFS
		55 – 94	N/A	>95	≤2	≤2.5	≤2.5	FFS
		95 – 149	>0	N/A	≤1.5	≤2	≤2	FFS
75 RB / 100 RB	2523.4	0 – 64	>0	N/A	≤5	≤5	≤5	FFS
		65 – 114	N/A	>115	≤2	≤2.5	≤2.5	FFS
		115 – 174	>0	N/A	≤1	≤1.5	≤2	FFS
100 RB / 100 RB	2528.3	0 – 69	>0	N/A	≤5	≤5	≤5	FFS
		70 – 129	N/A	>130	≤2	≤2.5	≤2.5	FFS
		130 – 199	>0	N/A	≤1.5	≤1.5	≤2	FFS

NOTE 1:  $RB_{start}$  indicates the lowest RB index of transmitted resource blocks  
 NOTE 2:  $L_{CRB}$  is the length of a contiguous resource block allocation  
 NOTE 3: For intra-subframe frequency hopping which intersects regions, notes 1 and 2 apply on a per slot basis  
 NOTE 4: For intra-subframe frequency hopping which intersects regions, the larger A-MPR value may be applied for both slots in the subframe  
 NOTE 5: The A-MPR values in this table shall apply when the lower edge of the aggregated channel bandwidth (Figure 5.6A-1) is less than or equal to the lower edge cutoff frequency specified in this table for the corresponding CA bandwidth combination. When the lower edge of the aggregated channel bandwidth exceeds the lower edge cutoff frequency, then the A-MPR shall be equal to the MPR specified in Table 6.2.3A-1a.

If the UE is configured to CA\_41C or any uplink inter-band CA configuration containing CA\_41C and it receives IE CA\_NS\_04 the allowed maximum output power reduction applied to transmissions on two serving cells assigned to Band 41 with non-contiguous resource allocation is defined as follows for UE power class 3

$$A\text{-MPR} = \text{CEIL} \{M_A, 0.5\}$$

Where  $M_A$  is defined as follows

$$\begin{aligned}
 M_A &= 11, & 0 \leq A < 0.05 \\
 &= -55.0A + 13.75, & 0.05 \leq A < 0.15 \\
 &= -4.0A + 6.10, & 0.15 \leq A < 0.40 \\
 &= -0.83A + 4.83, & 0.40 \leq A \leq 1
 \end{aligned}$$

Where  $A = N_{RB\_alloc} / N_{RB\_agg}$ .

If the UE is configured to CA\_41C or any uplink inter-band CA configuration containing CA\_41C and it receives IE CA\_NS\_04 the allowed maximum output power reduction applied to transmissions on two serving cells assigned to Band 41 with non-contiguous resource allocation is defined as follows for UE power class 2

$$A\text{-MPR} = \text{CEIL} \{M_A, 0.5\}$$

If the UE is configured to CA\_41D or any uplink inter-band CA configuration containing CA\_41D and it receives IE CA\_NS\_04 the allowed maximum output power reduction applied to transmissions on two serving cells assigned to Band 41 with non-contiguous resource allocation is defined as follows for UE power class 3

$$A\text{-MPR} = \text{CEIL} \{M_A, 0.5\}$$

Where  $M_A$  is defined as follows

$$\begin{aligned} M_A &= 11.5, & 0 \leq A < 0.05 \\ &= -55.0A + 14.25, & 0.05 \leq A < 0.15 \\ &= -4.0A + 6.60, & 0.15 \leq A < 0.40 \\ &= -0.833A + 5.333, & 0.40 \leq A \leq 1 \end{aligned}$$

Where  $A = N_{\text{RB\_alloc}} / N_{\text{RB\_agg}}$ .

Where  $M_A$  is defined as follows when the lower edge of the aggregated channel bandwidth (Table 5.6A-1) is less than or equal to the lower edge cutoff frequency specified in Table 6.2.4A.4-2 for the corresponding CA bandwidth combination

$$\begin{aligned} M_A &= 13.0, & 0 \leq A < 0.05 \\ &= 15.33 - 46.67A, & 0.05 \leq A < 0.20 \\ &= -7.0 - 5.0A, & 0.20 \leq A < 0.50 \\ &= 4.5, & 0.50 \leq A \leq 1 \end{aligned}$$

And  $M_A$  is defined as follows when the lower edge of the aggregated channel bandwidth exceeds the lower edge cutoff frequency specified in Table 6.2.4A.4-2 for the corresponding CA bandwidth combination

$$\begin{aligned} M_A &= 8.2, & 0 \leq A < 0.04 \\ &= 9.8 - 40.0A, & 0.04 \leq A < 0.075 \\ &= 8.0 - 16.0A, & 0.075 \leq A < 0.25 \\ &= 4.83 - 3.33A, & 0.25 \leq A < 0.40 \\ &= 3.83 - 0.83A, & 0.40 \leq A \leq 1 \end{aligned}$$

Where  $A = N_{\text{RB\_alloc}} / N_{\text{RB\_agg}}$ .

#### 6.2.4A.5 A-MPR for CA\_NS\_05 for CA\_38C

If the UE is configured to CA\_38C and it receives IE CA\_NS\_05 the allowed maximum output power reduction applied to transmission on the PCC and the SCC for contiguously aggregated signals is specified in Table 6.2.4A.5-1.



Table 6.2.4A.5-1: Contiguous Allocation A-MPR for CA\_NS\_05

CA_38C	RB <sub>end</sub>	L <sub>CRB</sub> [RBs]	A-MPR for QPSK, 16 QAM, 64 QAM and 256 QAM [dB]
100RB/100RB	0 – 12	>0	≤ 5 dB
	13 – 79	> RB <sub>end</sub> – 13	≤ 2 dB
	80 – 180	>60	≤ 6 dB
	181 – 199	> 0	≤ 11 dB
75RB/75RB	0 – 70	> max (0, RB <sub>end</sub> -10)	≤ 2 dB
	71- 108	> 60	≤ 5 dB
	109 – 139	>0	≤ 5 dB
	140 – 149	≤ 70	≤ 2 dB
	140 – 149	>70	≤ 6 dB
NOTE 1: RB <sub>end</sub> indicates the highest RB index of transmitted resource blocks NOTE 2: L <sub>CRB</sub> is the length of a contiguous resource block allocation NOTE 3: For intra-subframe frequency hopping which intersects regions, notes 1 and 2 apply on a per slot basis. For intra-slot or intra-subslot frequency hopping which intersects regions, notes 1 and 2 apply on a per T <sub>no_hopping</sub> basis. NOTE 4: For intra-subframe frequency hopping which intersects regions, the larger A-MPR value may be applied for both slots in the subframe. For intra-slot frequency hopping which intersects regions, the larger A-MPR value may be applied for the slot. For intra-subslot frequency hopping which intersects regions, the larger A-MPR value may be applied for the subslot.			

If the UE is configured to CA\_38C and it receives IE CA\_NS\_05 the allowed maximum output power reduction applied to transmissions on the PCell and the SCell with non-contiguous resource allocation is defined as follows

$$A\text{-MPR} = \text{CEIL} \{M_A, 0.5\}$$

Where M<sub>A</sub> is defined as follows

$$M_A = -14.17 A + 16.50 \quad ; 0 \leq A < 0.60$$

$$-2.50 A + 9.50 \quad ; 0.60 \leq A \leq 1$$

Where  $A = N_{RB\_alloc} / N_{RB\_agg}$ .

#### 6.2.4A.6 A-MPR for CA\_NS\_06

If the UE is configured to CA\_7C and it receives IE CA\_NS\_06 the allowed maximum output power reduction applied to transmission on the PCC and the SCC for contiguously aggregated signals is specified in Table 6.2.4A.6-1.

Table 6.2.4A.6-1: Contiguous Allocation A-MPR for CA\_NS\_06

CA Bandwidth Class C	RB <sub>end</sub>	L <sub>CRB</sub> [RBs]	A-MPR for QPSK, 16 QAM, 64 QAM and 256 QAM [dB]
100RB/100RB	0 – 22	> 0	≤ 4 dB
	23 – 99	> max(0, RB <sub>end</sub> – 25)	≤ 2 dB
	100 – 142	> 75	≤ 3 dB
	143 – 177	> 70	≤ 5 dB
	178 – 199	> 0	≤ 10 dB
75RB/75RB	0 – 7	> 0	≤ 5 dB
	8 – 74	> max(0, RB <sub>end</sub> – 10)	≤ 2 dB
	75 – 109	> 64	≤ 2 dB
	110 – 144	> 35	≤ 6 dB
	145 – 149	> 0	≤ 10 dB
50RB/100RB and 100RB/50RB	0 – 10	> 0	≤ 5 dB
	11 – 75	> max(0, RB <sub>End</sub> – 25)	≤ 2 dB
	76 – 103	> 50	≤ 3 dB
	104 – 144	> 25	≤ 6 dB
75RB/100RB and 100RB/75RB	0 – 15	> 0	≤ 5 dB
	16 – 75	> max(0, RB <sub>End</sub> – 15)	≤ 2 dB
	76 – 120	> 50	≤ 3 dB
	121 – 160	> 50	≤ 6 dB
	161 – 174	> 0	≤ 10 dB

If the UE is configured to CA\_7C and it receives IE CA\_NS\_06 the allowed maximum output power reduction applied to transmissions on the PCell and the SCell with non-contiguous resource allocation is defined as follows:

$$A\text{-MPR} = \text{CEIL} \{M_A, 0.5\}$$

Where  $M_A$  is defined as follows

$$M_A = -13.33A + 17.5 \quad ; 0 \leq A < 0.15$$

$$-6.47A + 16.47 \quad ; 0.15 \leq A \leq 1$$

Where  $A = N_{RB\_alloc} / N_{RB\_agg}$ .

#### 6.2.4A.7 A-MPR for CA\_NS\_07

If the UE is configured to CA\_39C or any uplink inter-band CA configuration containing CA\_39C and it receives IE CA\_NS\_07 the allowed maximum output power reduction applied to transmission on two component carriers for contiguously aggregated signals is specified in Table 6.2.4A.7-1.

Table 6.2.4A.7-1: Contiguous Allocation A-MPR for CA\_NS\_07

CA_39C: CA_NS_07	RB <sub>Start</sub>	L <sub>CRB</sub> [RBs]	A-MPR for QPSK, 16 QAM, 64 QAM and 256 QAM [dB]
75 RB / 100 RB and 100 RB / 75 RB	0 – 13	> 0	≤ 11
	14 – 50	≤ 60	≤ 3
	14 – 100	> 60	≤ 7
	101 – 155	> max(155 - RB <sub>start</sub> , 0)	≤ 2
	156 – 174	> 0	≤ 5
50 RB / 100 RB and 100 RB / 50 RB	0 – 5	> 0	≤ 11
	6 – 42	≤ 25	≤ 3
		> 25	≤ 6
	43 – 80	> 50	≤ 5
	81 – 138	> 20	≤ 2
25 RB / 100 RB and 100 RB / 25 RB	139 – 149	> 0	≤ 5
		≥ 84	≤ 6
	0 – 32	< 84	≤ 4
	33 – 60	> 50	≤ 3
	61 – 124	> 20	≤ 3

If the UE is configured to CA\_39C or any uplink inter-band CA configuration containing CA\_39C and it receives IE CA\_NS\_07 the allowed maximum output power reduction applied to transmissions on two serving cells assigned to Band 39 with non-contiguous resource allocation is defined as follows

$$A\text{-MPR} = \text{CEIL} \{M_A, 0.5\}$$

Where  $M_A$  is defined as follows

$$M_A = -16.25A + 21 \quad ; 0 \leq A < 0.80$$

$$-2.50A + 10.00 \quad ; 0.80 \leq A \leq 1$$

Where  $A = N_{\text{RB\_alloc}} / N_{\text{RB\_agg}}$

#### 6.2.4A.8 A-MPR for CA\_NS\_08

If the UE is configured to CA\_42C and it receives IE CA\_NS\_08 the allowed maximum output power reduction applied to transmission on the PCC and the SCC for contiguously aggregated signals is specified in Table 6.2.4A.8-1.

Table 6.2.4A.8-1: Contiguous Allocation A-MPR for CA\_NS\_08

CA_42C: CA_NS_08	RBstart	Condition	RBend	L <sub>CRB</sub> [RBs]	A-MPR for QPSK, 16 QAM, 64 QAM and 256 QAM [dB]
100RB / 100RB	≤ 21	Or	≥ 178	≤ 25	≤ 12
	≥ 0	N/A	N/A	> 25 and ≤ 80	≤ 6
	> 21 and ≤ 58	Or	≥ 141 and < 178	> 80 and ≤ 172	≤ 8
	> 21	And	< 178	> 172	≤ 9
				≥ 48 and ≤ 80	≤ 4
100RB / 75RB And 75RB / 100RB	≤ 12	Or	≥ 162	≤ 25	≤ 12
	≥ 0	N/A	N/A	> 25 and ≤ 75	≤ 6
	> 12 and ≤ 49	Or	≥ 125 and < 162	> 75 and < 172	≤ 8
	> 12	And	< 162	≥ 172	9
	> 49	And	< 125	< 54	≤ 3
100RB / 50RB And 50RB / 100RB	≤ 5	Or	≥ 144	≤ 16	≤ 12
	≥ 0	N/A	N/A	> 16 and ≤ 61	≤ 6
	> 5	And	< 144	> 61	≤ 8
	> 5 and ≤ 41	Or	≥ 108 and < 144	≥ 36 and ≤ 61	≤ 5
100RB / 25RB And 25RB / 100RB	≤ 31	Or	≥ 92	< 36	≤ 3
	≥ 0	N/A	N/A	≤ 34	≤ 4
				> 34 and ≤ 44	≤ 5
<p>NOTE 1: RB<sub>start</sub> indicates the lowest RB index of transmitted resource blocks</p> <p>NOTE 2: L<sub>CRB</sub> is the length of a contiguous resource block allocation</p> <p>NOTE 3: RB<sub>end</sub> indicates the highest RB index of transmitted resource blocks</p> <p>NOTE 4: If condition is "and" both RB<sub>start</sub> and RB<sub>end</sub> constraints need to be met. If condition is "or" either RB<sub>start</sub> or RB<sub>end</sub> constraints need to be met</p> <p>NOTE 5: For intra-subframe frequency hopping which intersects regions, notes 1, 2, 3 and 4 apply on a per slot basis. For intra-slot or intra-subslot frequency hopping which intersects regions, notes 1,2,3 and 4 apply on a per T<sub>no_hopping</sub> basis.</p> <p>NOTE 6: For intra-subframe frequency hopping which intersects regions, the larger A-MPR value may be applied for both slots in the subframe. For intra-slot frequency hopping which intersects regions, the larger A-MPR value may be applied for the slot. For intra-subslot frequency hopping which intersects regions, the larger A-MPR value may be applied for the subslot.</p>					

If the UE is configured to CA\_42C and it receives IE CA\_NS\_08 the allowed maximum output power reduction applied to transmissions on the PCell and the SCell with non-contiguous resource allocation is defined as follows

$$A\text{-MPR} = \text{CEIL} \{M_A, 0.5\}$$

Where MA is defined as follows

$$M_A = \begin{cases} 20 & ; 0 \leq A < 0.025 \\ 23 - 120A & ; 0.025 \leq A < 0.05 \\ 17.53 - 10.59A & ; 0.05 \leq A \leq 0.9 \\ 8 & ; 0.9 \leq A \leq 1 \end{cases}$$

Where  $A = N_{RB\_alloc} / N_{RB\_agg}$ .

## 6.2.4A.9 Void

## 6.2.4A.10 A-MPR for CA\_NS\_10

If the UE is configured to CA\_48C and it receives IE CA\_NS\_10 the allowed maximum output power reduction applied to transmission on the PCC and the SCC for contiguously aggregated signals is specified in Table 6.2.4A.10-2 or Table 6.2.4A.10-3. Which table is determined by the position of the carrier centre frequency in Table 6.2.4A.10-1.

Table 6.2.4A.10-1: A-MPR regions for CA\_48C

Channel Bandwidth, MHz	Carrier Centre Frequency, $F_c$ , MHz	A-MPR
20+5 / 5 + 20	$F_L + BW_{CA}/2 \leq F_c <$ $F_L + 3 \cdot BW_{CA}/2 - 10 \text{ MHz}$ $F_H - 3 \cdot BW_{CA}/2 + 10 \text{ MHz} \leq F_c \leq$ $F_H - BW_{CA}/2$	Table 6.2.4A.10-2
	$F_L + 3 \cdot BW_{CA}/2 - 10 \text{ MHz} \leq F_c < F_H -$ $3 \cdot BW_{CA}/2 + 10 \text{ MHz}$	Table 6.2.4A.10-3
20+10 / 10 + 20	$F_L + BW_{CA}/2 \leq F_c <$ $F_L + 3 \cdot BW_{CA}/2 - 10 \text{ MHz}$ $F_H - 3 \cdot BW_{CA}/2 + 10 \text{ MHz} \leq F_c <$ $F_H - BW_{CA}/2$	Table 6.2.4A.10-2
	$F_L + 3 \cdot BW_{CA}/2 - 10 \text{ MHz} \leq$ $F_c < F_H - 3 \cdot BW_{CA}/2 + 10 \text{ MHz}$	Table 6.2.4A.10-3
20+15 / 15 + 20	$F_L + BW_{CA}/2 \leq F_c <$ $F_L + 3 \cdot BW_{CA}/2 - 10 \text{ MHz}$ $F_H - 3 \cdot BW_{CA}/2 + 10 \text{ MHz} \leq F_c <$ $F_H - BW_{CA}/2$	Table 6.2.4A.10-2
	$F_L + 3 \cdot BW_{CA}/2 - 10 \text{ MHz} \leq$ $F_c < F_H - 3 \cdot BW_{CA}/2 + 10 \text{ MHz}$	Table 6.2.4A.10-3
20+20	$F_L + BW_{CA}/2 \leq F_c <$ $F_L + 3 \cdot BW_{CA}/2 - 10 \text{ MHz}$ $F_H - 3 \cdot BW_{CA}/2 + 10 \text{ MHz} \leq F_c <$ $F_H - BW_{CA}/2$	Table 6.2.4A.10-2
	$F_L + 3 \cdot BW_{CA}/2 - 10 \text{ MHz} \leq$ $F_c < F_H - 3 \cdot BW_{CA}/2 + 10 \text{ MHz}$	Table 6.2.4A.10-3

NOTE:  $F_L = 3550 \text{ MHz}$ ,  $F_H = 3700 \text{ MHz}$  and  $BW_{CA}$  is the combined bandwidth of the contiguous CCs in the CA combination indicated.

Table 6.2.4A.10-2: A-MPR regions for CA\_48C at the band edge

BWs [MHz]	RB_start	L_CRB	A-MPR [dB] max(mods)
20+5 / 5 + 20	0 - 7 and 117 - 124		$\leq 12$
	5 - 25	$< 85$	$\leq 5,5$
		$\geq 85$	$\leq 6,5$
	26 - 120		$\leq 5$
20+10 / 10 + 20	0 - 13 and 135 - 149		$\leq 11$
	14 - 33	$< 85$	$\leq 5$
		$\geq 85$	$\leq 7$
	34 - 134		$\leq 6$
20+15 / 15 + 20	0 - 22 and 152 - 174		$\leq 11$
	23 - 42	$< 95$	$\leq 5,5$
		$\geq 95$	$\leq 7$
	43 - 151		$\leq 6$
20+20	0 - 31 and 165 - 199		$\leq 11$
	31 - 51	$< 100$	$\leq 5,5$
		$\geq 100$	$\leq 7$
	52 - 164	$< 100$	$\leq 4,5$
$\geq 100$		$\leq 6$	

Table 6.2.4A.10-3: A-MPR regions for CA\_48C at the band center (“range for lower A-MPR”)

BWs [MHz]	RB_start	L_CRB	A-MPR [dB] max(mods)
20+5 / 5 + 20	0 – 7 and 117 - 124		≤ 4
	5 - 25	<85	≤ 2
		≥85	≤ 2,5
	26 - 120		≤ 2
20+10 / 10 + 20	0 - 13 and 135 - 149		≤ 4,5
	14 - 33	<85	≤ 1,5
		≥85	≤ 2,5
	34 - 134		≤ 1,5
20+15 / 15 + 20	0 - 22 and 152 -174		≤ 4,5
	23 - 42	<95	≤ 1
		≥95	≤ 2,5
	43 - 151		≤ 1
20+20	0 - 31 and 165 - 199		≤ 4,5
	31 - 51	<100	≤ 1
		≥100	≤ 1,5
	52 - 164	<100	≤ 1
≥100		≤ 1	

If the UE is configured to CA\_48C and it receives IE CA\_NS\_10 the allowed maximum output power reduction applied to transmissions on the PCell and the SCell with non-contiguous resource allocation is defined with both an edge and a center scenario and is determined in Table 6.2.4A.10-4.

Table 6.2.4A.10-4: A-MPR regions for CA\_48C

Channel Bandwidth, MHz	Carrier Centre Frequency, $F_c$ , MHz	A-MPR
20+5 / 5 + 20	$F_L + BW_{CA}/2 \leq F_c <$ $F_L + 3 \cdot BW_{CA}/2 - 10 \text{ MHz}$ $F_H - 3 \cdot BW_{CA}/2 + 10 \text{ MHz} \leq F_c \leq$ $F_H - BW_{CA}/2$	Edge
	$F_L + 3 \cdot BW_{CA}/2 - 10 \text{ MHz} \leq F_c < F_H -$ $3 \cdot BW_{CA}/2 + 10 \text{ MHz}$	Center
20+10 / 10 + 20	$F_L + BW_{CA}/2 \leq F_c <$ $F_L + 3 \cdot BW_{CA}/2 - 10 \text{ MHz}$ $F_H - 3 \cdot BW_{CA}/2 + 10 \text{ MHz} \leq F_c <$ $F_H - BW_{CA}/2$	Edge
	$F_L + 3 \cdot BW_{CA}/2 - 10 \text{ MHz} \leq$ $F_c < F_H - 3 \cdot BW_{CA}/2 + 10 \text{ MHz}$	Center
20+15 / 15 + 20	$F_L + BW_{CA}/2 \leq F_c <$ $F_L + 3 \cdot BW_{CA}/2 - 10 \text{ MHz}$ $F_H - 3 \cdot BW_{CA}/2 + 10 \text{ MHz} \leq F_c <$ $F_H - BW_{CA}/2$	Edge
	$F_L + 3 \cdot BW_{CA}/2 - 10 \text{ MHz} \leq$ $F_c < F_H - 3 \cdot BW_{CA}/2 + 10 \text{ MHz}$	Center
20+20	$F_L + BW_{CA}/2 \leq F_c <$ $F_L + 3 \cdot BW_{CA}/2 - 10 \text{ MHz}$ $F_H - 3 \cdot BW_{CA}/2 + 10 \text{ MHz} \leq F_c <$ $F_H - BW_{CA}/2$	Edge
	$F_L + 3 \cdot BW_{CA}/2 - 10 \text{ MHz} \leq$ $F_c < F_H - 3 \cdot BW_{CA}/2 + 10 \text{ MHz}$	Center
NOTE: $F_L = 3550 \text{ MHz}$ , $F_H = 3700 \text{ MHz}$ and $BW_{CA}$ is the combined bandwidth of the contiguous CCs in the CA combination indicated.		

The Edge scenario is defined as follows

$$A\text{-MPR} = \text{CEIL} \{M_A, 0.5\}$$

where  $M_A$  is defined as follows

$$M_A = \begin{array}{ll} 18.00 - 10.00 \text{ A}; & 0 \leq A < 0.05 \\ 18.50 - 20.00 \text{ A}; & 0.05 \leq A < 0.2 \\ 15.50 - 5.00 \text{ A}; & 0.2 \leq A < 1 \end{array}$$

where  $A = N_{RB\_alloc} / N_{RB\_agg}$ .

The Center scenario is defined as follows

$$A\text{-MPR} = \text{CEIL} \{M_A, 0.5\}$$

where  $M_A$  is defined as follows

$$M_A = \begin{array}{ll} 11.50 - 10.00 \text{ A}; & 0 \leq A < 0.15 \\ 10.88 - 5.88 \text{ A}; & 0.15 \leq A < 1 \end{array}$$

where  $A = N_{RB\_alloc} / N_{RB\_agg}$

For CA\_48B contiguous resource allocation when  $3560 \text{ MHz} \leq F_{agg\_alloc\_low} \leq 3680 \text{ MHz}$

if allocation is inner 1 then A-MPR = 0 dB where inner 1 is defined as

$$RB_{Start,Low} = \max(1, \text{floor}(L_{CRB}/2))$$

where  $\max()$  indicates the largest value of all arguments and  $\text{floor}(x)$  is the greatest integer less than or equal to  $x$ .

$$RB_{Start,High} = N_{RB\_agg} - RB_{Start,Low} - L_{CRB}$$

with following conditions

$$RB_{Start,Low} \leq RB_{Start} \leq RB_{Start,High}, \text{ and}$$

$$LCRB \leq \text{ceil}(N_{RB\_agg} / 2)$$

Inner 1 region exceptions thresholds are

$$RB_{start} < 12 \text{ and } RB_{end} \geq 92 \text{ for } BW_{Channel\_CA} = 20\text{MHz, and}$$

$$RB_{start} < 6 \text{ and } RB_{end} \geq 71 \text{ for } BW_{Channel\_CA} = 15\text{MHz,}$$

For which AMPR = 4 dB.

else A-MPR= 4 dB

For CA\_48B contiguous resource allocation when  $F_{agg\_alloc\_low} < 3560$  MHz

if allocation is inner 3 then A-MPR = 0 dB

Inner 3 region exceptions thresholds are

$$RB_{start} < 20 \text{ for } BW_{Channel\_CA} = 20\text{MHz, and}$$

$$RB_{start} < 10 \text{ for } BW_{Channel\_CA} = 15\text{MHz,}$$

For which AMPR = 7dB.

where inner 3 is defined as

$$RB_{Start} = N_{RB\_agg} / 4$$

$$LCRB = N_{RB\_agg} / 4$$

$$RB_{Start} = N_{RB\_agg} / 4 - LCRB$$

with following conditions

$$N_{RB\_agg} / 4 < RB_{Start} < N_{RB\_agg} / 4 - LCRB \quad \text{AND} \quad LCRB < N_{RB\_agg} / 4$$

else A-MPR = 7 dB.

For CA\_48B contiguous resource allocation when  $F_{agg\_alloc\_high} > 3690$  MHz

if allocation is inner 3 then A-MPR = 0 dB

Inner 3 region exceptions thresholds are

$$RB_{start} > 70 \text{ for } BW_{Channel\_CA} = 20\text{MHz, and}$$

$$RB_{start} > 62 \text{ for } BW_{Channel\_CA} = 15\text{MHz,}$$

For which AMPR = 7dB.

where inner 3 is defined as

$$RB_{Start} = N_{RB\_agg} / 4$$

$$LCRB = N_{RB\_agg} / 4$$

$$RB_{Start} = N_{RB\_agg} / 4 - LCRB$$

with following conditions

$$N_{RB\_agg} / 4 < RB_{Start} < N_{RB\_agg} / 4 - LCRB \quad \text{AND} \quad LCRB < N_{RB\_agg} / 4$$

else A-MPR = 7 dB.



For CA\_48B non-contiguous resource allocation when  $3560 \text{ MHz} \leq F_{\text{agg\_alloc\_low}} \leq 3680 \text{ MHz}$

$A = \text{NRB\_alloc} / \text{NRB\_agg}$

A-MPR=	13.00;	$0.00 \leq A \leq 0.08$
	$13.78 - 9.78 A$ ;	$0.08 < A \leq 1.00$

For CA\_48B non-contiguous resource allocation when  $F_{\text{agg\_alloc\_low}} < 3560 \text{ MHz}$  or  $F_{\text{agg\_alloc\_high}} > 3690 \text{ MHz}$

A-MPR=	13.00;	$0.00 \leq A \leq 0.08$
	$14.13 - 14.06 A$ ;	$0.08 < A \leq 0.40$
	$9.17 - 1.67 A$ ;	$0.40 < A \leq 1.00$

## 6.2.4B UE maximum output power with additional requirements for UL-MIMO

For UE with two transmit antenna connectors in closed-loop spatial multiplexing scheme, the A-MPR values specified in subclause 6.2.4 shall apply to the maximum output power specified in Table 6.2.2B-1. The requirements shall be met with the UL-MIMO configurations specified in Table 6.2.2B-2. For UE supporting UL-MIMO, the maximum output power is measured as the sum of the maximum output power at each UE antenna connector. Unless stated otherwise, an A-MPR of 0 dB shall be used.

For the UE maximum output power modified by A-MPR, the power limits specified in subclause 6.2.5B apply.

If UE is configured for transmission on single-antenna port, the requirements in subclause 6.2.4 apply.

## 6.2.4D UE maximum output power with additional requirements for ProSe

When UE is configured for E-UTRA ProSe sidelink transmissions non-concurrent with E-UTRA uplink transmissions for E-UTRA ProSe operating bands specified in Table 5.5D-1, the allowed A-MPR for the maximum output power for ProSe physical channels PSDCH, PSCCH, PSSCH, and PSBCH shall be as specified in subclause 6.2.4 for PUSCH for the corresponding modulation and transmission bandwidth.

The allowed A-MPR for the maximum output power for ProSe physical signal PSSS and SSSS shall be as specified in subclause 6.2.4 for PUSCH QPSK modulation for the corresponding transmission bandwidth.

When UE is configured for simultaneous E-UTRA ProSe sidelink and E-UTRA uplink transmissions for inter-band E-UTRA ProSe / E-UTRA bands specified in Table 5.5D-2, the requirements in subclause 6.2.4D apply for ProSe transmission and the requirements in subclause 6.2.4 apply for uplink transmission.

## 6.2.4E UE maximum output power with additional requirements for category M1 and M2 UE

Additional ACLR and spectrum emission requirements can be signalled by the network to indicate that the UE shall also meet additional requirements in a specific deployment scenario. To meet these additional requirements, Additional Maximum Power Reduction (A-MPR) is allowed for the output power as specified in Table 6.2.2E-1 and Table 6.2.4E-2. Unless stated otherwise, an A-MPR of 0 dB shall be used.

For UE Power Class 3 and 5 the specific requirements and identified subclauses are specified in Table 6.2.4E-1 and Table 6.2.4E-2 along with the allowed A-MPR values that may be used to meet these requirements. The allowed A-MPR values specified below in Table 6.2.4E-1 and Table 6.2.4E-2 and from 6.2.4-2 to 6.2.4-15 are in addition to the allowed MPR requirements specified in subclause 6.2.3E.

Table 6.2.4E-1: Additional Maximum Power Reduction (A-MPR) for category M1 UE

Network Signalling value	Requirements (subclause)	E-UTRA Band	Resources Blocks ( $M_{RB}$ )	A-MPR (dB)
NS_01	6.6.2.1.1	Table 5.5-1	Table 5.6-1	N/A
NS_03	6.6.2.2.1	2, 4	Table 5.6-1	N/A
NS_04	6.6.2.2.2	41	Table 6.2.4E-3	
NS_05	6.6.3.3.1	1	Table 5.6-1	N/A
NS_06	6.6.2.2.3	12, 13, 14, 85	Table 5.6-1	N/A
NS_07	6.6.2.2.3 6.6.3.3.2	13	Table 6.2.4E-4	
NS_08	6.6.3.3.3	19	Table 5.6-1	N/A
NS_09	6.6.3.3.4	21, 74	Table 5.6-1	N/A
NS_10		20	Table 5.6-1	N/A
NS_12	6.6.3.3.5	26	Table 6.2.4E-5	
NS_13	6.6.3.3.6	26	Table 5.6-1	N/A
NS_14	6.6.3.3.7	26	Table 5.6-1	N/A
NS_15	6.6.3.3.8	26	Table 6.2.4-9	
NS_16	6.6.3.3.9	27	Table 5.6-1	N/A
NS_17	6.6.3.3.10	28	Table 5.6-1	N/A
NS_18	6.6.3.3.11	28	Table 5.6-1	N/A
NS_22	6.6.3.3.16	42, 43	Table 5.6-1	N/A
NS_23	6.6.3.3.17	42, 43	Table 5.6-1	N/A
NS_32	-	-	-	-
NS_35	6.6.2.2.7	71	Table 5.6-1	N/A
NS_38	6.6.3.3.29	74	Table 5.6-1	N/A
NS_39	6.6.3.3.30	74	Table 5.6-1	N/A

Table 6.2.4E-2: Additional Maximum Power Reduction (A-MPR) for category M2 UE

Network Signalling value	Requirements (subclause)	E-UTRA Band	Narrowband bandwidth	Resources Blocks ( $M_{RB}$ )	A-MPR (dB)
NS_01	6.6.2.1.1	Table 5.5-1	1, 4, 3, 5	Table 5.6-1	N/A
NS_03	6.6.2.2.1	2, 4	3,5	Table 6.2.4-1	
NS_04	6.6.2.2.2	41	5	Table 6.2.4-1	
NS_05	6.6.3.3.1	1	1, 4, 3, 5	Table 6.2.4-18E	
NS_06	6.6.2.2.3	12, 13, 14, 85	1, 4, 3, 5	Table 5.6-1	N/A
NS_07	6.6.2.2.3 6.6.3.3.2	13		[TBD]	
NS_08	6.6.3.3.3	19	1, 4, 3, 5	Table 5.6-1	N/A
NS_09	6.6.3.3.4	21	1, 4, 3, 5	Table 5.6-1	N/A
NS_10		20	1, 4, 3, 5	Table 5.6-1	N/A
NS_12	6.6.3.3.5	26	1, 4, 3, 5	Table 6.2.4-1	
NS_13	6.6.3.3.6	26	5	Table 6.2.4-1	
NS_14	6.6.3.3.7	26	N/A	Table 5.6-1	N/A
NS_15	6.6.3.3.8	26	1, 4, 3, 5	Table 5.6-1	
NS_16	6.6.3.3.9	27	3,5	Table 6.2.4-1	
NS_17	6.6.3.3.10	28	5	Table 6.2.4-1	
NS_18	6.6.3.3.11	28	5	Table 6.2.4-1	
NS_22	6.6.3.3.16	42, 43	1, 4, 3, 5	Table 5.6-1	N/A
NS_23	6.6.3.3.17	42, 43	1, 4, 3, 5	Table 5.6-1	N/A
NS_32	-	-	-	-	-
NS_35	6.6.2.2.7	71	1, 4, 3, 5	Table 5.6-1	N/A

Table 6.2.4E-3: A-MPR for "NS\_04" for Cat-M1

Channel bandwidth [Hz]	Parameters	Region			
5	F <sub>c</sub> [MHz]	≤ 2500.5			
	(NB <sub>index</sub> , RB <sub>start</sub> )	(0, 0-5)		(1, 0-1)	
	LCRB [RBs]	> 0			
	A-MPR [dB]	≤ 2			
10	F <sub>c</sub> [MHz]	≤ 2504			
	(NB <sub>index</sub> , RB <sub>start</sub> )	(0, 0-5)		(1, 0-1)	
	LCRB [RBs]	> 0			
	A-MPR [dB]	≤ 3			
15	F <sub>c</sub> [MHz]	≤ 2510.8			
	(NB <sub>index</sub> , RB <sub>start</sub> )	(0, 0-5)		(1, 0-5)	
	LCRB [RBs]	> 0			
	A-MPR [dB]	≤ 3			
20	F <sub>c</sub> [MHz]	≤ 2517.5			
	(NB <sub>index</sub> , RB <sub>start</sub> )	(0, 0-5)	(1, 0-5)	(2, 0-5)	(3, 0-2)
	LCRB [RBs]	> 0			
	A-MPR [dB]	≤ 3			

NOTE 1: RB<sub>start</sub> indicates the lowest RB index of transmitted resource blocks  
NOTE 2: LCRB is the length of a contiguous resource block allocation  
NOTE 3: For intra-subframe frequency hopping which intersects regions, notes 1 and 2 apply on a per slot basis  
NOTE 4: For intra-subframe frequency hopping which intersects regions, the larger A-MPR value may be applied for both slots in the subframe  
NOTE 5: For CAT-M1 device, the NB index is the starting index allocated from DCI[6], the RB<sub>start</sub> is indexed within the NB allocated to cat-M1 device.

Table 6.2.4E-4: A-MPR for "NS\_07" for Cat-M1

BW [MHz]	5				10	
(NB <sub>index</sub> , RB <sub>start</sub> )	(0,<6)	(0,<6)	(3,<6)	(3,<6)	(0,<6)	(7,<6)
LCRB	>4 and <7	>1 and ≤4	>4 and <7	>1 and ≤4	>2 and <7	>2 and <7
AMPR [dB]	2	1	2	1	1	1

NOTE 1: NB<sub>index</sub> is the narrowband index that is defined in 6.2.7 in [4]. The resource block assignment is defined within the narrowband as defined in 5.3.3.1.12 and 5.3.3.1.13 in [5].

Table 6.2.4E-5: A-MPR for "NS\_12" for Cat-M1

Channel bandwidth [MHz]	Parameters	Region		
1.4	(NB <sub>index</sub> , RB <sub>start</sub> )	(0,0)		
	LCRB [RBs]	≤3	≥4	≥4
	A-MPR [dB]	≤3	≤6	≤3
3	(NB <sub>index</sub> , RB <sub>start</sub> )	(0,0-2)		
	LCRB [RBs]	>0		
	A-MPR [dB]	≤4		
5	(NB <sub>index</sub> , RB <sub>start</sub> )	(0, 0-5)		
	LCRB [RBs]	>0		
	A-MPR [dB]	≤5		
10	(NB <sub>index</sub> , RB <sub>start</sub> )	(0, 0-5)	(1, 0-5)	(2,0-2)
	LCRB [RBs]	>0		
	A-MPR [dB]	≤4		
15	(NB <sub>index</sub> , RB <sub>start</sub> )	(0-5,0-5)		
	LCRB [RBs]	>0		
	A-MPR [dB]	≤4		

For subPRB allocation, the allowed A-MPR values specified below in Table 6.2.4E-6 and Table 6.2.4E-7 for category M1 UE and category M2 UE respectively in addition to the allowed MPR requirements specified in subclause 6.2.3E.

**Table 6.2.4E-6: Additional Maximum Power Reduction (A-MPR) for category M1 UE for subPRB allocation**

Network Signalling value	Requirements (subclause)	E-UTRA Band	A-MPR (dB)
NS_01	6.6.2.1.1	Table 5.5-1	N/A
NS_03	6.6.2.2.1	2, 4	Table 6.2.4E-8
NS_04	6.6.2.2.2	41	Table 6.2.4E-9
NS_05	6.6.3.3.1	1	[N/A]
NS_06	6.6.2.2.3	12, 13, 14	Table 6.2.4E-13
NS_07	6.6.2.2.3 6.6.3.3.2	13	Table 6.2.4E-23
NS_08	6.6.3.3.3	19	[N/A]
NS_09	6.6.3.3.4	21, 74	[N/A]
NS_10		20	[N/A]
NS_12	6.6.3.3.5	26	Table 6.2.4E-14
NS_13	6.6.3.3.6	26	[N/A]
NS_14	6.6.3.3.7	26	[N/A]
NS_15	6.6.3.3.8	26	[N/A]
NS_16	6.6.3.3.9	27	[N/A]
NS_17	6.6.3.3.10	28	[N/A]
NS_18	6.6.3.3.11	28	[N/A]
NS_22	6.6.3.3.16	42, 43	[N/A]
NS_23	6.6.3.3.17	42, 43	[N/A]
NS_32	-	-	-
NS_35	6.6.2.2.7	71	Table 6.2.4E-15
NS_38	6.6.3.3.29	74	Table 6.2.4E-16
NS_39	6.6.3.3.30	74	[N/A]

**Table 6.2.4E-7: Additional Maximum Power Reduction (A-MPR) for category M2 UE for subPRB allocation**

Network Signalling value	Requirements (subclause)	E-UTRA Band	A-MPR (dB)
NS_01	6.6.2.1.1	Table 5.5-1	N/A
NS_03	6.6.2.2.1	2, 4	Table 6.2.4E-10
NS_04	6.6.2.2.2	41	Table 6.2.4E-11
NS_05	6.6.3.3.1	1	Table 6.2.4E-17
NS_06	6.6.2.2.3	12, 13, 14	Table 6.2.4E-18
NS_07	6.6.2.2.3 6.6.3.3.2	13	Table 6.2.4E-12
NS_08	6.6.3.3.3	19	N/A
NS_09	6.6.3.3.4	21	N/A
NS_10		20	N/A
NS_12	6.6.3.3.5	26	Table 6.2.4E-19
NS_13	6.6.3.3.6	26	Table 6.2.4E-20
NS_14	6.6.3.3.7	26	N/A
NS_15	6.6.3.3.8	26	Table 6.2.4E-21
NS_16	6.6.3.3.9	27	Table 6.2.4E-22
NS_17	6.6.3.3.10	28	N/A
NS_18	6.6.3.3.11	28	N/A
NS_22	6.6.3.3.16	42, 43	[N/A]
NS_23	6.6.3.3.17	42, 43	[N/A]
NS_32	-	-	-
NS_35	6.6.2.2.7	71	N/A
NS_38	6.6.3.3.29	74	Table 6.2.4E-24
NS_39	6.6.3.3.30	74	N/A

Table 6.2.4E-8: A-MPR for "NS\_03" for Cat-M1 with sub-PRB allocation

BW [MHz]		5 MHz			
(NB <sub>index</sub> , SC <sub>start</sub> )	(0, ≤9)	(0, ≥63)	(0, ≤9)	(0, ≥63)	
Lcsc	2	2	3,6	3,6	
AMPR [dB]	≤[0.5]	≤[0.5]	≤[1]	≤[1]	

NOTE 1: NB<sub>index</sub> is the narrowband index that is defined in 6.2.7 in [4]. The resource block assignment is defined within the narrowband as defined in 5.3.3.1.12 and 5.3.3.1.13 in [5].

NOTE 2: Lcsc is the length of the continuous subcarrier, SC<sub>start</sub> is the subcarrier offset relative to the first subcarrier of the first PRB of NB indicated with NB<sub>index</sub>.

Table 6.2.4E-9: A-MPR for "NS\_04" for Cat-M1 with sub-PRB allocation

BW [MHz]		5 MHz	
(NB <sub>index</sub> , SC <sub>start</sub> )	(0, ≤9)	(0, ≤9)	
Lcsc	2	3,6	
AMPR [dB]	≤[1]	≤[1.5]	

NOTE 1: NB<sub>index</sub> is the narrowband index that is defined in 6.2.7 in [4]. The resource block assignment is defined within the narrowband as defined in 5.3.3.1.12 and 5.3.3.1.13 in [5].

NOTE 2: Lcsc is the length of the continuous subcarrier, SC<sub>start</sub> is the subcarrier offset relative to the first subcarrier of the first PRB of NB indicated with NB<sub>index</sub>.

Table 6.2.4E-10: A-MPR for "NS\_03" for Cat-M2 with sub-PRB allocation

BW [MHz]		5 MHz					
(NB <sub>index</sub> , SC <sub>start</sub> )	(0, ≤72)	(0, ≥216)					
Lcsc	3,6	3,6					
AMPR [dB]	≤[1]	≤[1]					
BW [MHz]		10 MHz					
(NB <sub>index</sub> , SC <sub>start</sub> )	(0, ≤60)	(1, ≤24)	(3, ≥264)	(4, ≥228)			
Lcsc	3,6	3,6	3,6	3,6			
AMPR [dB]	≤[1]	≤[1]	≤[1]	≤[1]			

NOTE 1: NB<sub>index</sub> is the narrowband index that is defined in 6.2.7 in [4]. The resource block assignment is defined within the narrowband as defined in 5.3.3.1.12 and 5.3.3.1.13 in [5].

NOTE 2: Lcsc is the length of the continuous subcarrier, SC<sub>start</sub> is the subcarrier offset relative to the first subcarrier of the first PRB of NB indicated with NB<sub>index</sub>.

Table 6.2.4E-11: A-MPR for "NS\_04" for Cat-M2 with sub-PRB allocation

BW [MHz]		5MHz	
(NB <sub>index</sub> , SC <sub>start</sub> )	(0, ≤72)	(0, ≥216)	
Lcsc		≥2	
AMPR [dB]		≤[2]	

Table 6.2.4E-12: A-MPR for "NS\_07" for Cat-M2 with sub-PRB allocation

BW [MHz]	10 MHz		
	(0, <48)	(0,48-84)	(0, ≥240)
(NB <sub>index</sub> , SC <sub>start</sub> )	(0, <48)	(0,48-84)	(0, ≥240)
Lcsc	≥2	≥2	≥2
AMPR [dB]	≤[12]	≤[6]	≤[14.5]
(NB <sub>index</sub> , SC <sub>start</sub> )	(1, <24)	(1,24-72)	(1, ≥264)
Lcsc	≥2	≥2	≥2
AMPR [dB]	≤[12]	≤[6]	≤[14.5]
(NB <sub>index</sub> , SC <sub>start</sub> )	(2, <60)		(2, ≥252)
Lcsc	≥2		≥2
AMPR [dB]	≤[6]		≤[1.5]
(NB <sub>index</sub> , SC <sub>start</sub> )	(3, <48)		(3, ≥216)
Lcsc	≥2		≥2
AMPR [dB]	≤[6]		≤[1.5]
(NB <sub>index</sub> , SC <sub>start</sub> )	(4, <36)		(4, ≥192)
Lcsc	≥2		≥2
AMPR [dB]	≤[3]		≤[1.5]

Table 6.2.4E-13: A-MPR for "NS\_06" for Cat-M1 with sub-PRB allocation

BW [MHz]	1.4	3	5
(NB <sub>index</sub> , SC <sub>start</sub> )	(0, < 15) and (0, > 54)	((0], < 15)	((0], < 15)
Lcsc	[2]	[2]	[2]
AMPR [dB]	≤[0.5]	≤[0.5]	≤[0.5]

NOTE 1: NB<sub>index</sub> is the narrowband index that is defined in 6.2.7 in [4]. The resource block assignment is defined within the narrowband as defined in 5.3.3.1.12 and 5.3.3.1.13 in [5].

NOTE2: Lcsc is the length of the continuous subcarrier, SC<sub>start</sub> is the subcarrier offset relative to the first subcarrier of the first PRB of NB indicated with NB<sub>index</sub>.

Table 6.2.4E-14: A-MPR for "NS\_12" for Cat-M1 with sub-PRB allocation

Channel bandwidth [MHz]	Parameters	Region		
		([0], ≤ [3])	((0], ≤ [3])	((0], ≤ [3])
1.4	(NB <sub>index</sub> , SC <sub>start</sub> )	([0], ≤ [3])	((0], ≤ [3])	((0], ≤ [3])
	Lcsc	[2]	[3]	[6]
	A-MPR [dB]	≤ [5]	≤ [5]	≤ [5]
3	(NB <sub>index</sub> , SC <sub>start</sub> )	([0], ≤ [3])	((0], ≤ [3])	((0], ≤ [3])
	Lcsc	[2]	[3]	[6]
	A-MPR [dB]	≤ [5]	≤ [5]	≤ [5]
5	(NB <sub>index</sub> , SC <sub>start</sub> )	([0], ≤ [3])	((0], ≤ [3])	((0], ≤ [3])
	Lcsc	[2]	[3]	[6]
	A-MPR [dB]	≤ [5]	≤ [5]	≤ [5]

Table 6.2.4E-15: A-MPR for "NS\_35" for Cat-M1 with sub-PRB allocation

<b>BW [MHz]</b>	<b>5</b>
<b>(NB<sub>index</sub>, SC<sub>start</sub>)</b>	<b>((0), [0])</b>
Lcsc	[2]
AMPR [dB]	≤ [0.5]

NOTE 1: NB<sub>index</sub> is the narrowband index that is defined in 6.2.7 in [4]. The resource block assignment is defined within the narrowband as defined in 5.3.3.1.12 and 5.3.3.1.13 in [5].

NOTE2: Lcsc is the length of the continuous subcarrier, SC<sub>start</sub> is the subcarrier offset relative to the first subcarrier of the first PRB of NB indicated with NB<sub>index</sub>.

Table 6.2.4E-16: A-MPR for "NS\_38" for Cat-M1 with sub-PRB allocation for E-UTRA lowest channel edge &gt; 1427 MHz and ≤ 1447 MHz

Channel bandwidth [MHz]	Parameters	Region					
		(0), < 27)	((0), > 51)				
1.4	(NB <sub>index</sub> , SC <sub>start</sub> )	((0), < 27)	((0), > 51)				
	Lcsc	2,3,6	[3]				
	A-MPR [dB]	≤ [7]	≤ [1]				
3	(NB <sub>index</sub> , SC <sub>start</sub> )	((0), < 21)	((0), > 60)				
	Lcsc	2,3,6	2,3,6				
	A-MPR [dB]	≤ [7]	≤ [1]				
5	(NB <sub>index</sub> , SC <sub>start</sub> )	((0), < 21)	((0), > 60)				
	Lcsc	[2]	[2]				
	A-MPR [dB]	≤ [7]	≤ [1]				
10	(NB <sub>index</sub> , SC <sub>start</sub> )	(0, < 15)					
	Lcsc	2,3,6					
	A-MPR [dB]	≤ [7]					
15	(NB <sub>index</sub> , SC <sub>start</sub> )	(0, < 12)					
	Lcsc	2,3,6					
	A-MPR [dB]	≤ [7]					

Table 6.2.4E-17: A-MPR for "NS\_05" for Cat-M2 with sub-PRB allocation

BW [MHz]	5		10		15		20	
	(0, ≤36)	(0, ≤6)	(0, ≤30)	(0, ≤12)	(0, ≤24)	(0, ≤12)	(0,0)	(0,0)
Lcsc	2	6	2	6	2	6	2	3
AMPR [dB]	≤[1.5]	≤ [0.5]	≤[1.5]	≤[0.5]	≤[1.5]	≤[0.5]	≤[1.5]	≤[0.5]

NOTE 1: WB<sub>index</sub> is the wideband index that is defined in [4].

NOTE2: Lcsc is the length of the continuous subcarrier, SC<sub>start</sub> is the subcarrier offset relative to the first subcarrier of the first PRB indicated with WB<sub>index</sub>.

Table 6.2.4E-18: A-MPR for "NS\_06" for Cat-M2 with sub-PRB allocation

BW [MHz]	5 MHz				
(NB <sub>index</sub> , SC <sub>start</sub> )	(0, ≤72)	(0, ≥216)			
Lcsc	3,6	3,6			
AMPR [dB]	≤[1]	≤[1]			
BW [MHz]	10 MHz				
(NB <sub>index</sub> , SC <sub>start</sub> )	(0, ≤60)	(1, ≤24)	(3, ≥264)	(4, ≥228)	
Lcsc	3,6	3,6	3,6	3,6	
AMPR [dB]	≤[1]	≤[1]	≤[1]	≤[1]	

NOTE 1: NB<sub>index</sub> is the narrowband index that is defined in 6.2.7 in [4]. The resource block assignment is defined within the narrowband as defined in 5.3.3.1.12 and 5.3.3.1.13 in [5].

NOTE 2: Lcsc is the length of the continuous subcarrier, SC<sub>start</sub> is the subcarrier offset relative to the first subcarrier of the first PRB of NB indicated with NB<sub>index</sub>.

Table 6.2.4E-19: A-MPR for "NS\_12" for Cat-M2 with sub-PRB allocation for E-UTRA lower channel edge &gt;= 814.2 MHz and ≤ 829.2 MHz

BW [MHz]	5 MHz
(WB <sub>index</sub> , SC <sub>start</sub> )	(0, <84)
Lcsc	≥2
AMPR [dB]	≤[5]
BW [MHz]	10 MHz
(WB <sub>index</sub> , SC <sub>start</sub> )	(0, <72)
Lcsc	≥2
AMPR [dB]	≤[5]
BW [MHz]	15 MHz
(WB <sub>index</sub> , SC <sub>start</sub> )	(0, <66)
Lcsc	≥2
AMPR [dB]	≤[5]

NOTE 1: NB<sub>index</sub> is the narrowband index that is defined in 6.2.7 in [4]. The resource block assignment is defined within the narrowband as defined in 5.3.3.1.12 and 5.3.3.1.13 in [5].

NOTE 2: WB<sub>index</sub> is the wideband index that is defined in [4].

NOTE 3: Lcsc is the length of the continuous subcarrier, SC<sub>start</sub> is the subcarrier offset relative to the first subcarrier of the first PRB indicated with NB<sub>index</sub> or WB<sub>index</sub>.

Table 6.2.4E-20: A-MPR for "NS\_13" for Cat-M2 with sub-PRB allocation for E-UTRA lower channel edge &gt;= 819 MHz and ≤ 824 MHz

BW [MHz]	5	
(WB <sub>index</sub> , SC <sub>start</sub> )	(0, <30)	(0, <30)
Lcsc	2	3,6
AMPR [dB]	≤[3]	≤[5]

NOTE 1: WB<sub>index</sub> is the wideband index that is defined in [4].

NOTE 2: Lcsc is the length of the continuous subcarrier, SC<sub>start</sub> is the subcarrier offset relative to the first subcarrier of the first PRB indicated with WB<sub>index</sub>.



**Table 6.2.4E-21: A-MPR for "NS\_15" for Cat-M2 with sub-PRB allocation for E-UTRA highest channel edge > 834 MHz and ≤ 849 MHz**

BW [MHz]	5 MHz					
(WB <sub>index</sub> , SC <sub>start</sub> )	(0, <54)	(0, <54)	(0, <54)	(0, 200-234)	(0, >234)	(0, >234)
Lcsc	2	3	6	≥2	2,3	6
AMPR [dB]	≤[10.5]	≤[8.5]	≤[5.5]	≤[3.5]	≤[10]	≤[9]
BW [MHz]	10 MHz					
(WB <sub>index</sub> , SC <sub>start</sub> )	(1, <48)	(1, <48)	(1, <48)	(1, 200-234)	(1, >234)	(1, >234)
Lcsc	2	3	6	≥2	2,3	6
AMPR [dB]	≤[10.5]	≤[8.5]	≤[5.5]	≤[3.5]	≤[10]	≤[9]
BW [MHz]	15 MHz					
(WB <sub>index</sub> , SC <sub>start</sub> )	(2, <48)	(2, <48)	(2, <48)	(2, 200-234)	(2, >234)	(2, >234)
Lcsc	2	3	6	≥2	2,3	6
AMPR [dB]	≤[10.5]	≤[8.5]	≤[5.5]	≤[3.5]	≤[10]	≤[9]
NOTE 1: WB <sub>index</sub> is the wideband index that is defined in [4].						
NOTE 2: Lcsc is the length of the continuous subcarrier, SC <sub>start</sub> is the subcarrier offset relative to the first subcarrier of the first PRB indicated with WB <sub>index</sub>						

**Table 6.2.4E-22: A-MPR for "NS\_16" for Cat-M2 with sub-PRB allocation for E-UTRA lowest channel edge > 807 MHz and ≤ 812 MHz**

BW [MHz]	5 MHz
(WB <sub>index</sub> , SC <sub>start</sub> )	(0, <6)
Lcsc	2
AMPR [dB]	≤[7]
NOTE 1: WB <sub>index</sub> is the wideband index that is defined in [4].	
NOTE 2: Lcsc is the length of the continuous subcarrier, SC <sub>start</sub> is the subcarrier offset relative to the first subcarrier of the first PRB indicated with WB <sub>index</sub>	

**Table 6.2.4E-23: A-MPR for "NS\_07" for Cat-M1 with sub-PRB allocation**

BW [MHz]	10
(NB <sub>index</sub> , SC <sub>start</sub> )	(0, < 9)
Lcsc	2
AMPR [dB]	≤ 0.5
NOTE 1: NB <sub>index</sub> is the narrowband index that is defined in 6.2.7 in [4]. The resource block assignment is defined within the narrowband as defined in 5.3.3.1.12 and 5.3.3.1.13 in [5].	
NOTE 2: Lcsc is the length of the continuous subcarrier, SC <sub>start</sub> is the subcarrier offset relative to the first subcarrier of the first PRB of NB indicated with NB <sub>index</sub> .	

**Table 6.2.4E-24: A-MPR for “NS\_38” for Cat-M2 with sub-PRB allocation for E-UTRA lowest channel edge > 1427 MHz and ≤ 1447 MHz**

Channel bandwidth [MHz]	Parameters	Region				
		(0, 0-27)	(0, 30-42)	(0, 45-51)	(0, 96-120)	(0, 123-168)
3	(NB <sub>index</sub> , SC <sub>start</sub> )	(0, 0-27)	(0, 30-42)	(0, 45-51)	(0, 96-120)	(0, 123-168)
	Lcsc	2,3,6	2,3,6	2,3,6	2,3,6	2,3,6
	A-MPR [dB]	≤ [16]	≤ [13]	≤ [10]	≤ [7]	≤ [3]
5	(WB <sub>index</sub> , SC <sub>start</sub> )	(0, < 96)	(0, > 219)			
	Lcsc	2,3,6	2,3,6			
	A-MPR [dB]	≤ [7]	≤ [1]			
10	(WB <sub>index</sub> , SC <sub>start</sub> )	(0, < 93)	(0, > 219)			
	Lcsc	2,3,6	2,3,6			
	A-MPR [dB]	≤ [7]	≤ [1]			
15	(WB <sub>index</sub> , SC <sub>start</sub> )	(0, < 87)	(0, > 234)			
	Lcsc	2,3,6	2,3,6			
	A-MPR [dB]	≤ [7]	≤ [1]			
20	(WB <sub>index</sub> , SC <sub>start</sub> )	(0, < 81)	(0, > 234)			
	Lcsc	2,3,6	2,3,6			
	A-MPR [dB]	≤ [7]	≤ [1]			

No other A-MPR requirement than those specified in table 6.2.4E-1, table 6.2.4E-2, table 6.2.4E-6 and table 6.2.4E-7 applies to category M1 and M2 UE.

#### 6.2.4F UE maximum output power with additional requirements for category NB1 and NB2 UE

Additional ACLR and spectrum emission requirements can be signalled by the network to indicate that the UE shall also meet additional requirements in a specific deployment scenario. To meet these additional requirements, Additional Maximum Power Reduction (A-MPR) is allowed for the output power are specified. For the agreed E-UTRA bands for category NB1 and NB2 UE an A-MPR of 0 dB shall be allowed unless specified otherwise.

For UE Power Class 3 and 5 the specific requirements and identified subclauses are specified in Table 6.2.4F-1 along with the allowed A-MPR values that may be used to meet these requirements. The allowed A-MPR values specified below in Table 6.2.4F-1 are in addition to the allowed MPR requirements specified in subclause 6.2.3F-1.

**Table 6.2.4F-1: Additional Maximum Power Reduction (A-MPR) for category NB1 and NB2 UE**

Network Signalling value	Requirements (subclause)	E-UTRA Band	A-MPR (dB)
NS_01	6.6.2F.1	Operating bands defined in 5.5F	N/A
NS_02	6.6.2F.2.1	[1, 2, 3, 5, 8, 11, 12, 13, 17, 18, 19, 20, 21, 25, 26, 28, 66, 70 and 85]	[N/A]
NS_03	6.6.2F.2.2	[1, 2, 3, 5, 8, 11, 12, 13, 17, 18, 19, 20, 21, 25, 26, 28, 66, 70 and 85]	[N/A]
NS_04	5.5F	26	N/A

## 6.2.4G UE maximum output power with additional requirements for V2X Communication

For QPSK the MPR requirements specified in subclause 6.2.3G does not apply, i.e.  $MPR = 0\text{dB}$ . For 16QAM and 64 QAM, the applied maximum output power reduction is obtained by taking the maximum value of MPR requirements specified in subclause 6.2.3G and A-MPR requirements specified in subclause 6.2.4G.

When UE is configured for E-UTRA V2X sidelink transmissions non-concurrent with E-UTRA uplink transmissions for E-UTRA V2X operating bands specified in Table 5.5G-1, the maximum output power reduction specified as

$$A\text{-MPR} = \text{CEIL}\{M_A, 0.5\}$$

Where  $M_A$  is defined as follows

$$M_A = A\text{-MPR}_{\text{Base}} + G_{\text{post connector}} * A\text{-MPR}_{\text{Step}}$$

$\text{CEIL}\{M_A, 0.5\}$  means rounding upwards to closest 0.5dB.

$A\text{-MPR}_{\text{Base}}$  and  $A\text{-MPR}_{\text{Step}}$  are specified in Tables 6.2.4G-1, 6.2.4G-2, 6.2.4G-3 is allowed when network signalling value is provided. The supported post antenna connector gain  $G_{\text{post connector}}$  is declared by the UE following the principle described in annex I.

NOTE: the  $A\text{-MPR}_{\text{step}}$  is the increase in A-MPR allowance to allow UE to meet tighter conducted A-SE and A-SEM requirements with higher value of declared  $G_{\text{post connector}}$ .  $A\text{-MPR}_{\text{Base}}$  is the default A-MPR value when no  $G_{\text{post connector}}$  is declared.  $A\text{-MPR}_{\text{Base}}$  and  $A\text{-MPR}_{\text{step}}$  vary depending on channel frequency and RB allocation. For channel frequencies and RB allocations that are close to the frequency range 5815-5855MHz, those value are much higher due to stringent emission requirement in this range.

**Table 6.2.4G-1: Additional Maximum Power Reduction (A-MPR) for power class 3 V2X UE**

Network Signalling value	Requirements (subclause)	E-UTRA Band	Channel bandwidth (MHz)	A-MPR (dB)
NS_33	6.6.2.2.4 (A-SEM) 6.6.3.2 (A-SE) 6.6.2G	47	10	Table 6.2.4G-2

Table 6.2.4G-2: A-MPR for NS\_33

Resource pool	Carrier frequency(MHz)	Resources Blocks ( $N_{RB}$ )	Start Resource Block	A-MPR <sub>Base</sub>	A-MPR <sub>Step</sub>
Adjacent	5860	$\leq 6$	0	20	0.86
			5,6	8	0.64
			10,12	6	0.50
			$\geq 15$	5	0.93
		$>6$ and $\leq 10$	0	15.5	0.86
			5, 6	8	0.64
			10, 12	6	0.50
			$\geq 15$	5	0.93
		$>10$ and $\leq 22$	0	15	0.71
			5, 6	11.5	0.64
			10, 12	10	0.57
			15, 18	6	0.57
	20, 24, 25		5	0.57	
	$\geq 30$		4.5	0.64	
	$>22$	0, 5, 6	12.5	0.71	
		10, 12	10.5	0.57	
		15, 18	9.5	0.64	
		20, 24, 25	6.5	0.71	
	5870, 5910, 5920	$<20$		3	0.64
		$\geq 20$ and $\leq 45$	$\geq 0$	1.5	0.43
$>45$			2.5	0.36	
5880, 5890, 5900	$<10$		3	0.43	
	$\geq 10$ and $\leq 38$	$\geq 0$	1.5	0.50	
	$>38$		2	0.43	
Non-Adjacent	5860	$\leq 5$	$\geq 0$	13.5	1
		$>5$		11.5	1
	5870, 5910, 5920	$\leq 5$	$\geq 0$	5	1
		$>5$ and $\leq 42$		3	1
		$>42$		4.5	1
	5880, 5890, 5900	$\leq 18$	$\geq 0$	3.5	1
		$>18$ and $\leq 42$		2.5	1
		$>42$		3	1

The allowed A-MPR for the maximum output power for V2X physical signal PSBCH and PSSS/SSSS shall be as specified in subclause 6.2.4 for the corresponding modulation and transmission bandwidth.

When UE is configured for simultaneous E-UTRA V2X sidelink and E-UTRA uplink transmissions for inter-band E-UTRA V2X / E-UTRA bands specified in Table 5.5G-2, the requirements in subclause 6.2.4G apply for V2X PSSCH and PSCCH transmission. The allowed A-MPR requirements in subclause 6.2.4D apply for other V2X sidelink transmission (PSBCH/PSSS/SSSS). The A-MPR requirements in subclause 6.2.4 apply for uplink transmission.

When UE is configured for E-UTRA V2X sidelink transmissions non-concurrent with E-UTRA uplink transmissions for E-UTRA V2X operating bands specified in Table 5.5G-1, the allowed A-MPR for the maximum output power for V2X physical channels PSCCH and PSSCH shall be as specified in Table 6.2.4G-3 and 6.2.4G-4 for V2X UE power class 2.

Table 6.2.4G-3: Additional Maximum Power Reduction (A-MPR) for power class 2 V2X UE

Network Signalling value	Requirements (subclause)	E-UTRA Band	Channel bandwidth (MHz)	A-MPR (dB)
NS_34	6.6.2.2.4 (A-SEM) 6.6.3.2 (A-SE) 6.6.2G	47	10	Table 6.2.4G-4

Table 6.2.4G-4: A-MPR for NS_34 Resource pool	Carrier frequency(MHz)	Resources Blocks ( $N_{RB}$ )	A-MPR (dB)	
Adjacent	5860	<20	15	
		>20 and <30	13	
		>30	12	
Non-Adjacent	5870, 5900, 5880, 5890, 5900	<15 or >40	1	
		5860	-	12.5
			<10	5.5
Non-Adjacent	5910, 5920	>10 and <20	3	
		5870, 5880, 5890, 5900	<10	5.5

## 6.2.5 Configured transmitted power

The UE is allowed to set its configured maximum output power  $P_{CMAX,c}$  for serving cell  $c$ . The configured maximum output power  $P_{CMAX,c}$  is set within the following bounds:

$$P_{CMAX_L,c} \leq P_{CMAX,c} \leq P_{CMAX_H,c} \text{ with}$$

$$P_{CMAX_L,c} = \text{MIN} \{P_{EMAX,c} - \Delta T_{C,c}, (P_{PowerClass} - \Delta P_{PowerClass}) - \text{MAX}(MPR_c + A-MPR_c + \Delta T_{IB,c} + \Delta T_{C,c} + \Delta T_{ProSe}, P-MPR_c)\}$$

$$P_{CMAX_H,c} = \text{MIN} \{P_{EMAX,c}, P_{PowerClass} - \Delta P_{PowerClass}\}$$

where

- $P_{EMAX,c}$  is the value given by IE *P-Max* for serving cell  $c$ , defined in [7];
- $P_{PowerClass}$  is the maximum UE power specified in Table 6.2.2-1 without taking into account the tolerance specified in the Table 6.2.2-1;
- $\Delta P_{PowerClass} = 3$  dB for a power class 2 capable UE operating in Band 41, when *P-max* of 23 dBm or lower is indicated or if the uplink/downlink configuration is 0 or 6 in the cell; otherwise,  $\Delta P_{PowerClass} = 0$  dB
- $MPR_c$  and  $A-MPR_c$  for serving cell  $c$  are specified in subclause 6.2.3 and subclause 6.2.4, respectively;
- $\Delta T_{IB,c}$  is the additional tolerance for serving cell  $c$  as specified in Table 6.2.5-2;  $\Delta T_{IB,c} = 0$  dB otherwise;
- $\Delta T_{C,c} = 1.5$  dB when NOTE 2 in Table 6.2.2-1 applies;

- $\Delta T_{C,c} = 0$  dB when NOTE 2 in Table 6.2.2-1 does not apply;
- $\Delta T_{ProSe} = 0.1$  dB when the UE supports ProSe Direct Discovery and/or ProSe Direct Communication on the corresponding E-UTRA ProSe band;  $\Delta T_{ProSe} = 0$  dB otherwise.
- For a power class higher than default UE power class capable UE,  $\Delta P_{PowerClass} = P_{PowerClass} - P_{PowerClass\_Default}$  dB, when the band is a TDD band whose frame configuration is 0 or 6; or P-max is not indicated in the cell; or P-Max is provided and set to the maximum output power of the default power class or lower, otherwise,  $\Delta P_{PowerClass} = 0$  dB.

P-MPR<sub>c</sub> is the allowed maximum output power reduction for

- a) ensuring compliance with applicable electromagnetic energy absorption requirements and addressing unwanted emissions / self desense requirements in case of simultaneous transmissions on multiple RAT(s) for scenarios not in scope of 3GPP RAN specifications;
- b) ensuring compliance with applicable electromagnetic energy absorption requirements in case of proximity detection is used to address such requirements that require a lower maximum output power.

The UE shall apply P-MPR<sub>c</sub> for serving cell *c* only for the above cases. For UE conducted conformance testing P-MPR shall be 0 dB

NOTE 1: P-MPR<sub>c</sub> was introduced in the P<sub>C<sub>MAX,c</sub></sub> equation such that the UE can report to the eNB the available maximum output transmit power. This information can be used by the eNB for scheduling decisions.

NOTE 2: P-MPR<sub>c</sub> may impact the maximum uplink performance for the selected UL transmission path.

T<sub>REF</sub> and T<sub>eval</sub> are specified in Table 6.2.5-0 for different TTI patterns. For each T<sub>REF</sub>, the P<sub>C<sub>MAX,L,c</sub></sub> for serving cell *c* is evaluated per T<sub>eval</sub> and given by the minimum value taken over the transmission(s) within the T<sub>eval</sub>; the minimum P<sub>C<sub>MAX,L,c</sub></sub> over the one or more T<sub>eval</sub> is then applied for the entire T<sub>REF</sub>. P<sub>PowerClass</sub> shall not be exceeded by the UE during any period of time.

**Table 6.2.5-0: P<sub>C<sub>MAX</sub></sub> evaluation window for different TTI patterns**

TTI pattern	T <sub>REF</sub>	T <sub>eval</sub>	T <sub>eval</sub> with frequency hopping
Subframe	1 subframe	1 slot	1 slot
Subslot	2 OS	2 OS	Min(T <sub>no_hopping</sub> , 2OS)
Slot	7 OS	7 OS	Min(T <sub>no_hopping</sub> , 7OS)

The measured configured maximum output power P<sub>UMAX,c</sub> shall be within the following bounds:

$$P_{C_{MAX,L,c}} - \text{MAX}\{T_{L,c}, T(P_{C_{MAX,L,c}})\} \leq P_{UMAX,c} \leq P_{C_{MAX,H,c}} + T(P_{C_{MAX,H,c}}).$$

where the tolerance T(P<sub>C<sub>MAX,c</sub></sub>) for applicable values of P<sub>C<sub>MAX,c</sub></sub> is specified in Table 6.2.5-1, and Table 6.2.5-1A. The tolerance T<sub>L,c</sub> is the absolute value of the lower tolerance for the applicable operating band as specified in Table 6.2.2-1.

**Table 6.2.5-1: P<sub>C<sub>MAX</sub></sub> tolerance**

P <sub>C<sub>MAX,c</sub></sub> (dBm)	Tolerance T(P <sub>C<sub>MAX,c</sub></sub> ) (dB)
23 < P <sub>C<sub>MAX,c</sub></sub> ≤ 33	2.0
21 ≤ P <sub>C<sub>MAX,c</sub></sub> ≤ 23	2.0
20 ≤ P <sub>C<sub>MAX,c</sub></sub> < 21	2.5
19 ≤ P <sub>C<sub>MAX,c</sub></sub> < 20	3.5
18 ≤ P <sub>C<sub>MAX,c</sub></sub> < 19	4.0
13 ≤ P <sub>C<sub>MAX,c</sub></sub> < 18	5.0
8 ≤ P <sub>C<sub>MAX,c</sub></sub> < 13	6.0
-40 ≤ P <sub>C<sub>MAX,c</sub></sub> < 8	7.0

**Table 6.2.5-1A:  $P_{\text{CMAX}}$  tolerance for power class 5**

$P_{\text{CMAX},c}$ (dBm)	Tolerance T( $P_{\text{CMAX},c}$ ) (dB)
$P_{\text{CMAX},c} = 20$	2.0
$19 \leq P_{\text{CMAX},c} < 20$	3.5
$18 \leq P_{\text{CMAX},c} < 19$	4.0
$13 \leq P_{\text{CMAX},c} < 18$	5.0
$8 \leq P_{\text{CMAX},c} < 13$	6.0
$-40 \leq P_{\text{CMAX},c} < 8$	7.0

**Table 6.2.5-1B:  $P_{\text{CMAX}}$  tolerance for power class 6 for category M1 and M2 UE**

$P_{\text{CMAX},c}$ (dBm)	Tolerance T( $P_{\text{CMAX},c}$ ) (dB)
$13 \leq P_{\text{CMAX},c} \leq 14$	2.5
$12 \leq P_{\text{CMAX},c} < 13$	3.5
$11 \leq P_{\text{CMAX},c} < 12$	4
$8 \leq P_{\text{CMAX},c} < 11$	5
$5 \leq P_{\text{CMAX},c} < 8$	6.0
$-40 \leq P_{\text{CMAX},c} < 5$	7.0

For the UE which supports inter-band carrier aggregation configurations with the uplink assigned to one or two E-UTRA bands the  $\Delta T_{\text{IB},c}$  is defined for applicable bands in Table 6.2.5-2, Table 6.2.5-3 and Table 6.2.5-4 where unless otherwise stated, the same  $\Delta T_{\text{IB},c}$  is applicable to E-UTRA band(s) part for CA configurations which have the same E-UTRA operating band combination.

**Table 6.2.5-2:  $\Delta T_{\text{IB},c}$  (two bands)**

E-UTRA operating band combination	E-UTRA Band	$\Delta T_{\text{IB},c}$ [dB]
CA_1-3, CA_1-1-3, CA_1-1-3-3, CA_1-3-3	1	0.3
	3	0.3
CA_1-5	1	0.3
	5	0.3

CA_1-7, CA_1-1-7, CA_1-7-7	1	0.5
	7	0.6
CA_1-8	1	0.3
	8	0.3
CA_1-11	1	0.3
	11	0.3
CA_1-18	1	0.3
	18	0.3
CA_1-19	1	0.3
	19	0.3
CA_1-20	1	0.3
	20	0.3
CA_1-21	1	0.3
	21	0.3
CA_1-26	1	0.3
	26	0.3
CA_1-28, CA_1-1-28	1	0.3
	28	0.6
CA_1-32	1	0.5
	32	N/A
CA_1-38	1	0.5
	38	0.5
CA_1-40	1	0.5
	40	0.5
CA_1-41 <sup>8</sup>	1	0.5
	41	0.5
CA_1-42, CA_1-42-42	1	0.3
	42	0.8
CA_1-43	1	0.3
	43	0.8
CA_1-46	1	0
CA_2-4, CA_2-2-4, CA_2-4-4, CA_2-2-4-4	2	0.5
	4	0.5
CA_2-5, CA_2-2-5	2	0.3
	5	0.3
CA_2-7, CA_2-2-7, CA_2-7-7	2	0.5
	7	0.5
CA_2-12, CA_2-2-12, CA_2-12-12, CA_2-2-12-12	2	0.3
	12	0.3
CA_2-13, CA_2-2-13	2	0.3
	13	0.3
CA_2-14, CA_2-2-14	2	0.3
	14	0.3
CA_2-17	2	0.3
	17	0.8
CA_2-26	2	0.3
	26	0.3
CA_2-28	2	0.3
	28	0.3
CA_2-29, CA_2-2-29	2	0.3
CA_2-30, CA_2-2-30	2	0.5
	30	0.3
CA_2-46, CA_2-2-46, CA_2-46-46	2	0
CA_2-48, CA_2-48-48	2	0.6
	48	0.8
CA_2-49	2	0.6
	2	0.5



CA_2-66, CA_2-2-66, CA_2-66-66, CA_2-2-66-66, CA_2-66-66-66	66	0.5
CA_2-71, CA_2-2-71	2 71	0.3 0.3
CA_3-5, CA_3-3-5	3 5	0.3 0.3
CA_3-7, CA_3-3-7, CA_3-7-7, CA_3-3-7-7	3 7	0.5 0.5
CA_3-8, CA_3-3-8	3 8	0.3 0.3
CA_3-11	3 11	0.8 0.9
CA_3-18	3 18	0.3 0.3
CA_3-19, CA_3-3-19	3 19	0.3 0.3
CA_3-20, CA_3-3-20	3 20	0.3 0.3
CA_3-21, CA_3-3-21	3 21	0.8 0.9
CA_3-26	3 26	0.3 0.3
CA_3-27	3 27	0.3 0.3
CA_3-28	3 28	0.3 0.3
CA_3-31	3 31	0.3 0.6
CA_3-32	3	0.5
CA_3-38	3 38	0.5 0.5
CA_3-40, CA_3-40-40	3 40	0.5 0.5
CA_3-41, CA_3-3-41	3 41	0.5 0.3 <sup>10</sup> 0.8 <sup>11</sup>
CA_3-42, CA_3-3-42, CA_3-42-42	3 42	0.6 0.8
CA_3-43	3 43	0.3 0.8
CA_3-46, CA_3-3-46	3	0
CA_3-69	3	0.5
CA_4-5, CA_4-4-5	4 5	0.3 0.3
CA_4-7, CA_4-4-7, CA_4-7-7	4 7	0.5 0.5
CA_4-12, CA_4-4-12, CA_4-12-12, CA_4-4-12-12	4 12	0.3 0.8
CA_4-13, CA_4-4-13	4 13	0.3 0.3
CA_4-17	4 17	0.3 0.8
CA_4-27	4 27	0.3 0.3
CA_4-28	4 28	0.3 0.6
CA_4-29, CA_4-4-29	4	0.3

CA_4-30,	4	0.5
CA_4-4-30	30	0.3
CA_4-46,	4	0
CA_4-46-46		
CA_4-48	4	0.3
	48	0.8
CA_4-71,	4	0.3
CA_4-4-71	71	0.3
CA_5-7, CA_5-	5	0.3
7-7	7	0.3
CA_5-12,	5	0.8
CA_5-12-12	12	0.4
CA_5-13	5	0.5
	13	0.5
CA_5-17	5	0.8
	17	0.4
CA_5-25	5	0.3
	25	0.3
CA_5-28	5	0.5
	28	0.5
CA_5-29	5	0.5
CA_5-30	5	0.3
	30	0.3
CA_5-38	5	0.3
	38	0.3
CA_5-40,	5	0.3
CA_5-5-40,		
CA_5-40-40	40	0.3
CA_5-41	5	0.3
	41	0.3
CA_5-46	5	0
CA_5-48	5	0.3
	48	0.3
CA_5-66,	5	0.3
CA_5-5-66,		
CA_5-66-66,		
CA_5-5-66-66	66	0.3
CA_7-8, CA_7-	7	0.3
7-8	8	0.6
CA_7-12	7	0.3
	12	0.3
CA_7-13	7	0.3
	13	0.3
CA_7-20,	7	0.3
CA_7-7-20	20	0.3
CA_7-22	7	0.5
	22	0.8
CA_7-26,	7	0.3
CA_7-7-26	26	0.3
CA_7-28,	7	0.3
CA_7-7-28	28	0.3
CA_7-29	7	0.3
CA_7-7-29		
CA_7-30	7	0.5
	30	0.5
CA_7-32	7	0.7
CA_7-40	7	0.5
	40	[0.6]
CA_7-42,	7	0.5
CA_7-42-42	42	0.8
CA_7-46,	7	0
CA_7-7-46		
CA_7-66,	7	0.5
CA_7-7-66,		
CA_7-66-66,		
CA_7-7-66-66	66	0.5

CA_8-11	8	0.3
	11	0.4
CA_8-20	8	0.4
	20	0.4
CA_8-27	8	0.8
	27	0.8
CA_8-28 <sup>14</sup>	8	0.6
	28	0.5
CA_8-32	8	0.3
CA_8-38	8	0.3
	38	0.3
CA_8-39	8	0.3
	39	0.3
CA_8-40	8	0.3
	40	0.3
CA_8-41	8	0.3
	41	0.3
CA_8-42	8	0.6
	42	0.8
CA_8-46	8	0
CA_11-18	11	0.3
	18	0.3
CA_11-26	11	0.3
	26	0.3
CA_11-28	11	0.4
	28	0.6
CA_11-41	11	0.3
	41	0.3
CA_11-42	11	0.4
	42	0.8
CA_11-46	11	0
CA_12-25	12	0.3
	25	0.3
CA_12-30	12	0.3
	30	0.3
CA_12-46	12	0
	46	0
CA_12-48	12	0.3
	48	0.3
CA_12-66, CA_12-66-66	12	0.8
	66	0.3
CA_13-46, CA_13-46-46	13	0
CA_13-48, CA_13-48-48	13	0.3
	48	0.3
CA_13-66, CA_13-66-66	13	0.3
	66	0.3
CA_14-30	14	0.3
	30	0.3
CA_14-66, CA_14-66-66, CA_14-66-66- 66	14	0.3
	66	0.3
CA_18-28 <sup>9</sup>	18	0.5
	28	0.5
CA_18-41	18	0.3
	41	0.3
CA_19-21	19	0.3
	21	0.4
CA_19-28 <sup>9</sup>	19	0.5
	28	0.5
CA_18-42	18	0.3
	42	0.8
CA_19-42	19	0.3
	42	0.8
CA_19-46	19	0

CA_20-28	20	0.5
	28	0.5
CA_20-31	20	0.5
	31	0.5
CA_20-32	20	0.3
	20	0.3
CA_20-38	38	0.3
	20	0.3
CA_20-40, CA_20-40-40	40	0.3
	20	0.3
CA_20-41	41	0.3
	20	0.6
CA_20-42, CA_20-42-42	42	0.8
	20	0.3
CA_20-43	43	0.8
	20	0.5
CA_20-67	20	0.5
	20	0.3
CA_20-75	20	0.3
	20	0.3
CA_21-28	21	0.4
	28	0.3
CA_21-42	21	0.4
	42	0.8
CA_21-46	21	0
	23	0.3
CA_23-29	23	0.3
	25	0.3
CA_25-26, CA_25-25-26	26	0.3
	25	0.5
CA_25-41, CA_25-25-41	41	0.4 <sup>10</sup>
		0.9 <sup>11</sup>
CA_25-46	25	0
	46	0
CA_26-41	26	0.3
	41	0.3
CA_26-46	26	0
	26	0.3
CA_26-48, CA_26-48-48	48	0.3
	26	0.3
A_26-66	66	0.3
	28	0.3
CA_28-32	28	0.3
CA_28-38	28	0.3
	38	0.3
CA_28-40	28	0.3
	40	0.3
CA_28-41	28	0.3
	41	0.3
CA_28-42, CA_28-42-42	42	0.8
	28	0.5
CA_28-46	28	0
	28	0.6
CA_28-66	66	0.3
	30	0.3
CA_29-30	30	0.3
	66	0.3
CA_29-66, CA_29-66-66	66	0.3
	70	0.3
CA_30-66, CA_30-66-66	30	0.3
	66	0.5
CA_32-42	42	0.8
	43	0.8
CA_32-43	43	0.8
	34	0 <sup>1</sup>
CA_34-39	39	0 <sup>1</sup>
	34	0 <sup>1</sup>
CA_34-41	41	0 <sup>1</sup>
	38	0 <sup>4</sup>
CA_38-40, CA_38-40-40	40	0 <sup>4</sup>
	39	0 <sup>4</sup>
CA_39-40	39	0 <sup>4</sup>

	40	0 <sup>4</sup>
CA_39-41	39	0 <sup>4</sup>
	41	0 <sup>4</sup>
CA_39-41	39	0.5 <sup>7</sup>
	41	0.5 <sup>7</sup>
CA_39-42	39	0 <sup>4</sup>
	42	0.5 <sup>4</sup>
CA_39-46	39	0
CA_40-41	40	0.5 <sup>4</sup>
	41	0.5 <sup>4</sup>
CA_40-42	40	0 <sup>4</sup>
	42	0.5 <sup>4</sup>
CA_40-43	40	0 <sup>4</sup>
	43	0.5 <sup>4</sup>
CA_40-46	40	0
CA_41-42,	41	0 <sup>4</sup>
CA_41-42-42	42	0.5 <sup>4</sup>
CA_41-42,	41	0.3 <sup>7</sup>
CA_41-42-42	42	0.8 <sup>7</sup>
CA_41-46	41	0
CA_41-48	41	0 <sup>4</sup>
	48	0.5 <sup>4</sup>
CA_42-43	42	0 <sup>4</sup>
	43	0 <sup>4</sup>
CA_42-46	42	[0.5]
CA_46-48,	48	0.8
CA_46-48-48		
CA_46-66, CA_46-46-66, CA_46-66-66	66	0
CA_46-70	70	0
CA_46-71	71	0
CA_48-66, CA_48-48-66, CA_48-66-66, CA_48-48-66- 66	48	0.8
	66	0.6
CA_48-71, CA_48-48-71	48	0.3
	71	0.3
CA_66-70,	66	0.5
CA_66-66-70	70	0.5
CA_66-71,	66	0.3
CA_66-66-71	71	0.3
CA_70-71	70	0.3
	71	0.6

NOTE 1:	The above additional tolerances are only applicable for the E-UTRA operating bands that belong to the supported inter-band carrier aggregation configurations
NOTE 2:	The above additional tolerances also apply in non-aggregated operation for the supported E-UTRA operating bands that belong to the supported inter-band carrier aggregation configurations
NOTE 3:	In case the UE supports more than one of the above 2DL inter-band carrier aggregation configurations and a E-UTRA operating band belongs to more than one 2DL inter-band carrier aggregation configurations then: <ul style="list-style-type: none"> <li>- When the E-UTRA operating band frequency range is <math>\leq 1</math>GHz, the applicable additional tolerance shall be the average of the 2DL tolerances above, truncated to one decimal place for that operating band among the supported 2DL CA configurations. In case there is a harmonic relation between low band UL and high band DL, then the maximum tolerance among the different supported 2DL carrier aggregation configurations involving such band shall be applied</li> <li>- When the E-UTRA operating band frequency range is <math>&gt;1</math>GHz, the applicable additional 2DL tolerance shall be the maximum tolerance above that applies for that operating band among the supported 2DL CA configurations</li> </ul>
NOTE 4:	Only applicable for UE supporting inter-band carrier aggregation with uplink in one E-UTRA band and without simultaneous Rx/Tx.
NOTE 5:	Unless otherwise specified, in case the UE supports more than one of the above 3DL inter-band carrier aggregation configurations and a E-UTRA operating band belongs to more than one 3DL inter-band carrier aggregation configurations then: <ul style="list-style-type: none"> <li>- When the E-UTRA operating band frequency range is <math>\leq 1</math>GHz and the tolerances are the same, the value applies to the band. If the tolerances are different, the applicable additional 3DL tolerance is FFS. In case there is a harmonic relation between low band UL and high band DL, then the maximum tolerance among the different supported 3DL carrier aggregation configurations involving such band shall be applied</li> <li>- When the E-UTRA operating band frequency range is <math>&gt;1</math>GHz, the applicable additional 3DL tolerance shall be the maximum tolerance above that applies for that operating band among the supported 3DL CA configurations.</li> </ul>
NOTE 6:	The above additional tolerances applicable for the E-UTRA operating bands that belong to the supported highest order inter-band carrier aggregation configuration, also applies to the same E-UTRA operating bands that belong to a supported lower order CA configuration.
NOTE 7:	Applicable for UE supporting inter-band carrier aggregation without simultaneous Rx/Tx.
NOTE 8:	Only applicable for UE supporting inter-band carrier aggregation with the uplink active in the FDD band.
NOTE 9:	For Band 28, the requirements only apply for the restricted frequency range specified for this CA configuration (Table 5.5A-2).
NOTE 10:	The requirement is applied for UE transmitting on the frequency range of 2545-2690MHz.
NOTE 11:	The requirement is applied for UE transmitting on the frequency range of 2496-2545MHz.
NOTE 12:	For UE supporting E-UTRA band 65 and CA configurations including Band 1, the Band 65 $\Delta T_{IB,c}$ is the $\max(\text{Band 65 } \Delta T_{IB,c}, \text{Band 1 } \Delta T_{IB,c})$
NOTE 13:	For UE supporting E-UTRA band 42, 43 or 48 and CA configurations including Band 42, 43 or 48, the applicable $\Delta T_{IB,c}$ in Band 42, 43, or 48 is the $\max(\text{Band 42 } \Delta T_{IB,c}, \text{Band 43 } \Delta T_{IB,c}, \text{Band 48 } \Delta T_{IB,c})$ .
NOTE 14:	Only applicable for UE supporting inter-band carrier aggregation with the uplink active in Band 8.

NOTE: The above additional tolerances do not apply to supported UTRA operating bands with frequency range below 1 GHz that correspond to the E-UTRA operating bands that belong to the supported inter-band carrier aggregation configurations when such bands are belonging only to band combination(s) where one band is  $<1$ GHz and another band is  $>1.7$ GHz and there is no harmonic relationship between the low band UL and high band DL. Otherwise the above additional tolerances also apply to supported UTRA operating bands that correspond to the E-UTRA operating bands that belong to the supported inter-band carrier aggregation configurations.

NOTE: To meet the  $\Delta T_{IB,c}$  requirements for CA\_3A-7A with state-of-the-art technology, an increase in power consumption of the UE may be required. It is also expected that as the state-of-the-art technology evolves in the future, this possible power consumption increase can be reduced or eliminated.

**Table 6.2.5-3:  $\Delta T_{IB,c}$  (three bands)**



E-UTRA operating band combination	E-UTRA Band	$\Delta T_{IB,c}$ [dB]
CA_1-3-5, CA_1-1-3-5, CA_1-3-3-5	1	0.3
	3	0.3
	5	0.3
CA_1-3-7, CA_1-1-3-7, CA_1-1-3-3-7, CA_1-3-3-7, CA_1-3-3-7-7, CA_1-3-7-7	1	0.6
	3	0.6
	7	0.6
CA_1-3-8, CA_1-3-3-8	1	0.3
	3	0.3
	8	0.3
CA_1-3-11	1	0.3
	3	0.8
	11	0.9
CA_1-3-18	1	0.3
	3	0.3
	18	0.3
CA_1-3-19, CA_1-3-3-19	1	0.3
	3	0.3
	19	0.3
CA_1-3-20, CA_1-3-3-20	1	0.3
	3	0.3
	20	0.3
CA_1-3-21, CA_1-3-3-21	1	0.3
	3	0.8
	21	0.9
CA_1-3-26	1	0.3
	3	0.3
	26	0.3
CA_1-3-28, CA_1-1-3-28, CA_1-3-3-28, CA_1-1-3-28	1	0.3
	3	0.3
	28	0.6
CA_1-3-32	1	0.5
	3	0.5
CA_1-3-38	1	0.5
	3	0.5
	38	0.5
CA_1-3-40	1	0.5
	3	0.5
	40	0.5
CA_1-3-41	1	0.5
	3	0.5
	41	$0.3^5/0.8^6$
CA_1-3-42, CA_1-3-3-42	1	0.6
	3	0.6
	42	0.8
CA_1-3-43	1	0.3
	3	0.3
	43	0.8
CA_1-3-46	1	0.3
	3	0.3
CA_1-5-7, CA_1-5-7-7	1	0.5
	5	0.3
	7	0.6
CA_1-5-28	1	0.3
	5	0.5
	28	0.6
CA_1-5-40	1	0.5
	5	0.3
	40	0.5
CA_1-5-41	1	0.5
	5	0.3
	41	0.5
CA_1-5-46	1	0.3
	5	0.3

CA_1-7-8, CA_1-7-7-8	1	0.5
	7	0.6
	8	0.6
CA_1-7-20, CA_1-7-7-20	1	0.5
	7	0.6
	20	0.3
CA_1-7-26, CA_1-7-7-26	1	0.5
	7	0.6
	26	0.3
CA_1-7-28	1	0.5
	7	0.6
	28	0.6
CA_1-7-32	1	0.7
	7	0.7
CA_1-7-38	1	0.5
CA_1-7-40	1	0.6
	7	0.8
	40	0.9
CA_1-7-42	1	0.6
	7	0.6
	42	0.8
CA_1-7-46	1	0.5
	7	0.6
CA_1-8-11	1	0.3
	8	0.3
	11	0.4
CA_1-8-20	1	0.3
	8	0.4
	20	0.4
CA_1-8-28 <sup>1)</sup>	1	0.3
	8	0.6
	28	0.6
CA_1-8-38	1	0.5
	8	0.3
	38	0.5
CA_1-8-40	1	0.5
	8	0.3
	40	0.5
CA_1-8-42	1	0.3
	8	0.6
	42	0.8
CA_1-11-18	1	0.3
	11	0.4
	18	0.3
CA_1-11-28	1	0.3
	11	0.4
	28	0.6
CA_1-11-42	1	0.3
	11	0.4
	42	0.8
CA_1-18-28	1	0.3
	18	0.5
	28	0.5
CA_1-18-41	1	0.5
	18	0.3
	41	0.5
CA_1-18-42	1	0.3
	18	0.3
	42	0.8
CA_1-19-21	1	0.3
	19	0.3
	21	0.4
CA_1-19-28	1	0.3
	19	0.5
	28	0.5

CA_1-19-42	1	0.3
	19	0.3
	42	0.8
CA_1-20-28	1	0.3
	20	0.6
	28	0.6
CA_1-20-32	1	0.5
	20	0.3
CA_1-20-38	1	0.5
	20	0.3
	38	0.5
CA_1-20-42	1	0.3
	20	0.3
	42	0.8
CA_1-20-43	1	0.3
	20	0.3
	43	0.8
CA_1-21-28	1	0.3
	21	0.4
	28	0.6
CA_1-21-42	1	0.3
	21	0.4
	42	0.8
CA_1-28-40	1	0.6
	28	0.3
	40	0.5
CA_1-28-42	1	0.3
	28	0.6
	42	0.8
CA_1-32-42	1	0.5
	42	0.8
CA_1-32-43	1	0.5
	43	0.8
CA_1-41-42 <sup>8, 13</sup>	1	0.5
	41	0.5
	42	0.8
CA_1-42-43 <sup>13</sup>	1	0.3
	42	0.8
	43	0.8

CA_2-4-5, CA_2-2-4-5, CA_2-4-4-5	2	0.5
	4	0.5
	5	0.3
CA_2-4-7, CA_2-4-7-7	2	0.5
	4	0.5
	7	0.5
CA_2-4-12, CA_2-2-4-12, CA_2-4-4-12, CA_2-4-12-12	2	0.5
	4	0.5
	12	0.8
CA_2-4-13	2	0.5
	4	0.5
	13	0.3
CA_2-4-28	2	0.5
	4	0.5
	28	0.8
CA_2-4-29	2	[0.5]
	4	0.5
CA_2-4-30	2	0.5
	4	0.5
	30	0.3
CA_2-4-71, CA_2-2-4-71	2	0.5
	4	0.5
	71	0.3
CA_2-5-12, CA_2-2-5-12, CA_2-5-12-12	2	0.3
	5	0.8
	12	0.4
CA_2-5-7	2	0.5
	5	0.3
	7	0.5
CA_2-5-13	2	0.3
	5	0.5
	13	0.5
CA_2-5-28	2	0.3
	5	0.8
	28	0.4
CA_2-5-29	2	0.3
	5	0.5
CA_2-5-30, CA_2-2-5-30	2	0.5
	5	0.3
	30	0.3
CA_2-5-46	2	0.3
	5	0.3
CA_2-5-66, CA_2-2-5-66, CA_2-5-66-66	2	0.5
	5	0.3
	66	0.5
CA_2-7-12, CA_2-2-7-12	2	0.5
	7	0.5
	12	0.3
CA_2-7-13, CA_2-7-7-13	2	0.5
	7	0.5
	13	0.3
2	2	0.5
7	7	0.5
28	26	0.3
CA_2-7-28	2	0.5
	7	0.5
	28	0.3
CA_2-7-29, CA_2-7-7-29	2	0.5
	7	0.5
CA_2-7-30	2	0.5
	7	0.5
	30	0.5
CA_2-7-46	2	0.5
	7	0.5

CA_2-7-66, CA_2-2-7-66, CA_2-7-7-66, CA_2-7-7-66-66, CA_2-7-66-66	2	0.5
	7	0.5
	66	0.5
CA_2-12-30, CA_2-2-12-30	2	0.5
	12	0.3
	30	0.3
CA_2-12-66, CA_2-2-12-66, CA_2-12-66-66, CA_2-2-12-66-66	2	0.5
	12	0.8
	66	0.5
CA_2-13-46	2	0.3
	13	0.3
CA_2-13-48, CA_2-13-48-48	2	0.6
	13	0.3
	48	0.8
CA_2-13-66, CA_2-2-13-66, CA_2-13-66-66	2	0.5
	13	0.3
	66	0.5
CA_2-14-30, CA_2-2-14-30	2	0.5
	14	0.3
	30	0.5
CA_2-14-66, CA_2-2-14-66, CA_2-14-66-66, CA_2-2-14-66-66, CA_2-14-66-66-66	2	0.5
	14	0.3
	66	0.5
CA_2-26-66	2	0.5
	26	0.3
	66	0.5
CA_2-28-66	2	0.5
	28	0.6
	66	0.5
CA_2-29-30, CA_2-2-29-30	2	0.5
	30	0.3
CA_2-29-66	2	0.5
	66	0.5
CA_2-30-66, CA_2-2-30-66, CA_2-30-66-66	2	0.5
	30	0.3
	66	0.5
CA_2-46-48	2	0.6
	48	0.8
CA_2-46-66, CA_2-46-46-66, CA_2-46-66-66	2	0.5
	66	0.5

CA_2-48-66, CA_2-48-48-66	2	0.6
	48	0.8
	66	0.6
CA_2-66-71 CA_2-2-66-71 CA_2-66-66-71	2	0.5
	66	0.5
	71	0.3
CA_3-5-7, CA_3-5-7-7, CA_3-3-5-7	3	0.5
	5	0.3
	7	0.5
CA_3-5-28 CA_3-3-5-28	3	0.3
	5	0.5
	28	0.5
CA_3-5-40, CA_3-5-40-40	3	0.5
	5	0.3
	40	0.5
CA_3-5-41	3	0.5
	5	0.3 <sup>18</sup>
	41	0.3 <sup>5</sup>
		0.8 <sup>6</sup>
CA_3-7-8, CA_3-3-7-8, CA_3-3-7-7-8	3	0.5
	7	0.5
	8	0.6
CA_3-7-20, CA_3-3-7-20, CA_3-7-7-20	3	0.5
	7	0.5
	20	0.3
CA_3-7-26, CA_3-7-7-26	3	0.5
	7	0.5
	26	0.3
CA_3-7-28, CA_3-3-7-28	3	0.5
	7	0.5
	28	0.3
CA_3-7-32	3	0.7
	7	0.7
CA_3-7-38	3	0.5
	7	0.5
	38	0.5
CA_3-7-40	3	0.6
	7	0.8
	40	0.9
CA_3-7-42	3	0.6
	7	0.6
	42	0.8
CA_3-7-46	3	0.5
	7	0.5
CA_3-8-11	3	0.8
	8	0.3
	11	0.9
CA_3-8-20	3	0.3
	8	0.4
	20	0.4
CA_3-8-28 <sup>12</sup>	3	0.3
	8	0.6
	28	0.5
CA_3-8-32	3	0.8
	8	0.3
CA_3-8-38	3	0.5
	8	0.3
	38	0.5
CA_3-8-40	3	0.5
	8	0.3
	40	0.5
CA_3-8-42	3	0.6
	8	0.6
	42	0.8
CA_3-11-18	3	0.8

	11	0.9
	18	0.3
CA_3-11-26	3	0.8
	11	0.9
	26	0.3
CA_3-11-28	3	0.8
	11	0.9
	28	0.6
CA_3-18-42	3	0.6
	18	0.3
	42	0.8
CA_3-19-21, CA_3-3-19-21	3	0.8
	19	0.3
	21	0.9
CA_3-19-42	3	0.6
	19	0.3
	42	0.8
CA_3-20-28, CA_3-3-20-28	3	0.3
	20	0.5
	28	0.5
CA_3-20-32	3	0.5
	20	0.3
CA_3-20-42	3	0.6
	20	0.3
	42	0.8
CA_3-20-43	3	0.3
	20	0.3
	43	0.8
CA_3-21-28	3	0.8
	21	0.9
	28	0.3
CA_3-21-42	3	0.8
	21	0.9
	42	0.8
CA_3-28-38	3	0.5
	28	0.5
	38	0.5
CA_3-28-40	3	0.5
	28	0.3
	40	0.5
CA_3-28-41	3	0.5
	28	0.3
	41	$0.3^5/0.8^6$
CA_3-28-42, CA_3-28-42-42	3	0.6
	28	0.5
	42	0.8
CA_3-32-42	3	0.6
	42	0.8
CA_3-32-43	3	0.3
	43	0.8
CA_3-32-46	3	0.5
CA_3-41-42 <sup>14</sup>	3	1
CA_3-41-42-42	41	$0.3^5/0.8^6$
	42	0.8
CA_3-42-43 <sup>13</sup>	3	0.6
	42	0.8
	43	0.8

CA_4-5-12, CA_4-5-12-12, CA_4-4-5-12	4	0.3
	5	0.8
	12	0.8
CA_4-5-13	4	0.3
	5	0.5
	13	0.5
CA_4-5-29	4	0.3
	5	0.5
CA_4-5-30, CA_4-4-5-30	4	0.5
	5	0.3
	30	0.3
CA_4-7-12	4	0.5
	7	0.5
	12	0.8
CA_4-7-28	4	0.5
	7	0.5
	28	0.6
CA_4-12-30, CA_4-4-12-30	4	0.5
	12	0.8
	30	0.3
CA_4-29-30, CA_4-4-29-30	4	0.5
	30	0.3
CA_5-7-28	5	0.5
	7	0.3
	28	0.5
CA_5-7-46	5	0.3
	7	0.3
CA_5-7-66 CA_5-7-66-66	5	0.3
	7	0.5
	66	0.5
CA_5-12-46	5	0.8
	12	0.4
CA_5-12-48	5	0.8
	12	0.4
	48	0.3
CA_5-12-66	5	0.3
	12	0.8
	66	0.8
CA_5-30-66, CA_5-30-66-66	5	0.3
	30	0.3
	66	0.5



CA_5-40-41	5	0.3
	40	0.5
	41	0.5
CA_5-46-66, CA_5-46-66-66	5	0.3
	66	0.3
CA_5-48-66	5	0.3
	48	0.8
	66	0.6
CA_7-8-20	7	0.3
	8	0.6
	20	[0.6]
CA_7-8-38	7	0.5
	8	0.5
	38	0.5
CA_7-8-40	7	0.5
	8	0.6
	40	0.6
CA_7-12-66	7	0.5
	12	0.8
	66	0.5
CA_7-13-66	7	0.5
	13	0.3
	66	0.5
CA_7-20-28	7	0.3
	20	0.6
	28	0.6
CA_7-20-32	7	0.7
	20	0.3
	32	N/A
CA_7-20-38	7	0.3
	20	0.3
	38	0.3
CA_7-20-42	7	0.3
	20	0.3
	42	0.8
CA_7-26-66	7	0.5
	26	0.3
	66	0.5
CA_7-28-38	7	0.3
	28	0.3
	38	0.3
CA_7-28-40	7	0.5
	28	0.3
	40	0.6
CA_7-29-66	7	0.5
	66	0.5
CA_7-30-66	7	0.5
	30	0.5
	66	0.5
CA_7-32-46	7	0.7
CA_7-46-66	7	0.5
	66	0.5

CA_8-11-28 <sup>17</sup>	8	0.6
	11	0.4
	28	0.6
CA_8-11-42	8	0.6
	11	0.4
	42	0.8
CA_8-20-28	8	0.6
	20	0.5
	28	0.5
CA_8-28-41 <sup>15</sup>	8	0.6
	28	0.5
	41	0.3
CA_8-39-41	8	0.3
	39	0.3 <sup>19</sup>
	41	0.3 <sup>19</sup>
CA_12-30-66, CA_12-30-66-66	12	0.8
	30	0.3
	66	0.5
CA_13-46-66	13	0.3
	66	0.3
CA_13-48-66	13	0.3
	48	0.8
	66	0.6
CA_14-30-66, CA_14-30-66-66	14	0.3
	30	0.3
	66	0.5
CA_19-21-42	19	0.3
	21	0.4
	42	0.8
CA_20-32-42	20	0.5
	42	0.8
CA_20-32-43	20	0.3
	43	0.8
CA_20-38-40 <sup>20</sup> , CA_20-38-40-40 <sup>20</sup>	20	0.3
	38	0.3
	40	0.3
CA_21-28-42	21	0.4
	28	0.5
	42	0.8
CA_25-26-41, CA_25-25-26-41	25	0.3
	26	0.3
	41	0.3
CA_28-41-42 <sup>10</sup> , CA_28-41-42-42 <sup>10</sup>	28	0.5
	41	0.3 <sup>1</sup>
	42	0.8 <sup>1</sup>
CA_29-30-66, CA_29-30-66-66	30	0.3
	66	0.5
	CA_29-46-66	66
CA_29-66-70, CA_29-66-66-70	66	0.5
	70	0.5
CA_32-42-43 <sup>13</sup>	42	0.8
	43	0.8

CA_46-48-66	48	0.8
	66	0.6
CA_46-48-71, CA_46-48-48-71	46	0
	48	0.8
	71	0.3
CA_66-70-71, CA_66-66-70-71	66	0.5
	70	0.5
	71	0.6

- NOTE 1: The above additional tolerances are only applicable for the E-UTRA operating bands that belong to the supported inter-band carrier aggregation configurations
- NOTE 2: The above additional tolerances also apply in non-aggregated operation for the supported E-UTRA operating bands that belong to the supported inter-band carrier aggregation configurations
- NOTE 3: Unless otherwise specified, in case the UE supports more than one of the above 3DL inter-band carrier aggregation configurations and a E-UTRA operating band belongs to more than one 3DL inter-band carrier aggregation configurations then:
- When the E-UTRA operating band frequency range is  $\leq 1$ GHz and the tolerances are the same, the value applies to the band. If the tolerances are different, the applicable additional 3DL tolerance is FFS. In case there is a harmonic relation between low band UL and high band DL, then the maximum tolerance among the different supported 3DL carrier aggregation configurations involving such band shall be applied
  - When the E-UTRA operating band frequency range is  $>1$ GHz, the applicable additional 3DL tolerance shall be the maximum tolerance above that applies for that operating band among the supported 3DL CA configurations
- NOTE 4: The above additional tolerances applicable for the E-UTRA operating bands that belong to the supported highest order inter-band carrier aggregation configuration, also applies to the same E-UTRA operating bands that belong to a supported lower order CA configuration.
- NOTE 5: The requirement is specified for the frequency range of 2545-2690MHz.
- NOTE 6: The requirement is specified for the frequency range of 2496-2545MHz.
- NOTE 7: For UE supporting E-UTRA band 65 and CA configurations including Band 1, the Band 65  $\Delta T_{IB,c}$  is the  $\max(\text{Band 65 } \Delta T_{IB,c}, \text{Band 1 } \Delta T_{IB,c})$
- NOTE 8: Only applicable for UE supporting inter-band carrier aggregation with the uplink active in Band 1 or Band 42.
- NOTE 9: Only applicable for UE supporting inter-band carrier aggregation with uplink in one E-UTRA band and without simultaneous Rx/Tx on Band 41 and Band 42.
- NOTE 10: Applicable for UE supporting inter-band carrier aggregation without simultaneous Rx/Tx among TDD bands.
- NOTE 11: Only applicable for UE supporting inter-band carrier aggregation with the uplink active in Band 1 or Band 8
- NOTE 12: Only applicable for UE supporting inter-band carrier aggregation with the uplink active in Band 3 or Band 8.
- NOTE 13: Applicable for UE supporting inter-band carrier aggregation without simultaneous Rx/Tx among TDD bands.
- NOTE 14: Applicable for UE supporting inter-band carrier aggregation without simultaneous Rx/Tx among TDD bands.
- NOTE 15: Only applicable for UE supporting inter-band carrier aggregation with the uplink active in Band 8 or Band 41.
- NOTE 16: For UE supporting E-UTRA band 42, 43 or 48 and CA configurations including Band 42, 43 or 48, the applicable  $\Delta T_{IB,c}$  in Band 42, 43, or 48 is the  $\max(\text{Band 42 } \Delta T_{IB,c}, \text{Band 43 } \Delta T_{IB,c}, \text{Band 48 } \Delta T_{IB,c})$ .
- NOTE 17: Only applicable for UE supporting inter-band carrier aggregation with the uplink active in Band 8 or Band 11.
- NOTE 18: The values in the table reflect what can be achieved with the present state of the art technology. They shall be reconsidered when the state of the art technology progresses.
- NOTE 19: Only applicable for UE supporting inter-band carrier aggregation with uplink in one E-UTRA band and without simultaneous Rx/Tx on band 39 and band 41
- NOTE 20: Only applicable for UE supporting inter-band carrier aggregation with uplink in one E-UTRA band and without simultaneous Rx/Tx among TDD bands

Table 6.2.5-4:  $\Delta T_{IB,c}$  (four bands)

E-UTRA operating band combination	E-UTRA Band	$\Delta T_{IB,c}$ [dB]
CA_1-3-5-7, CA_1-3-3-5-7, CA_1-3-5-7-7	1	0.6
	3	0.6
	5	0.3
	7	0.6
CA_1-3-5-28	1	0.3
	3	0.3
	5	0.5
	28	0.6
CA_1-3-5-40	1	0.5
	3	0.5
	5	0.3
	40	0.5
CA_1-3-5-41	1	0.5
	3	0.5
	5	0.3 <sup>9</sup>
	41	0.5 <sup>7</sup> 0.8 <sup>8</sup>
CA_1-3-7-8, CA_1-3-3-7-8, CA_1-3-7-7-8, CA_1-3-3-7-7-8	1	0.6
	3	0.6
	7	0.6
	8	0.6
CA_1-3-7-20, CA_1-3-3-7-20, CA_1-3-7-7-20	1	0.6
	3	0.6
	7	0.6
	20	0.3
CA_1-3-7-26, CA_1-3-7-7-26	1	0.6
	3	0.6
	7	0.6
	26	0.3
CA_1-3-7-28, CA_1-1-3-7-28, CA_1-1-3-3-7-28, CA_1-3-3-7-28, CA_1-3-7-7-28	1	0.6
	3	0.6
	7	0.6
	28	0.6
CA_1-3-7-32	1	0.6
	3	0.6
	7	0.6
CA_1-3-7-38	1	0.6
	3	0.6
CA_1-3-7-40	1	0.6
	3	0.6
	7	0.8
	40	0.9
CA_1-3-7-42	1	0.7
	3	0.7
	7	0.7
	42	0.8
CA_1-3-7-46	1	0.6
	3	0.6
	7	0.6
CA_1-3-8-11	1	0.3
	3	0.8
	8	0.3
	11	0.9
CA_1-3-8-20	1	0.3
	3	0.3
	8	0.4
	20	0.4

CA_1-3-8-28 <sup>10</sup>	1	0.3
	3	0.3
	8	0.6
	28	0.6
CA_1-3-8-38	1	0.5
	3	0.5
	8	0.3
	38	0.5
CA_1-3-8-40	1	0.5
	3	0.5
	8	0.3
	40	0.5
CA_1-3-8-42	1	0.6
	3	0.6
	8	0.6
	42	0.8
CA_1-3-11-28	1	0.3
	3	0.8
	11	0.9
	28	0.6
CA_1-3-18-42	1	0.6
	3	0.6
	18	0.3
	42	0.8
CA_1-3-19-21	1	0.3
	3	0.8
	19	0.3
	21	0.9
CA_1-3-19-42, CA_1-3-3-19-21	1	0.6
	3	0.6
	19	0.3
	42	0.8
CA_1-3-20-28, CA_1-3-3-20-28	1	0.3
	3	0.3
	20	0.6
	28	0.6
CA_1-3-20-32	1	0.5
	3	0.5
	20	0.3
	32	0.3
CA_1-3-20-42	1	0.6
	3	0.6
	20	0.3
	42	0.8
CA_1-3-20-43	1	0.3
	3	0.3
	20	0.3
	43	0.8
CA_1-3-21-28	1	0.3
	3	0.8
	21	0.9
	28	0.6
CA_1-3-21-42	1	0.6
	3	0.8
	21	0.9
	42	0.8
CA_1-3-28-40	1	0.5
	3	0.5
	28	0.6
	40	0.5
CA_1-3-28-42	1	0.6
	3	0.6
	28	0.6
	42	0.8
CA_1-3-32-42	1	0.6
	3	0.6

	42	0.8
	1	0.5
CA_1-3-32-43	3	0.5
	43	0.8
	1	0.6
CA_1-3-41-42	3	0.6
	41	0.5
	42	0.8
	1	0.6
CA_1-3-42-43 <sup>13</sup>	3	0.6
	42	0.8
	43	0.8
	1	0.6
CA_1-5-7-28	5	0.5
	7	0.6
	28	0.6
	1	0.5
CA_1-5-7-46	5	0.3
	7	0.6
	1	0.5
CA_1-7-8-20	7	0.6
	8	0.6
	20	0.6
	1	0.6
CA_1-7-8-40	7	0.8
	8	0.6
	40	0.9
	1	0.5
CA_1-7-20-28	7	0.6
	20	0.6
	28	0.6
	1	0.7
CA_1-7-20-32	7	0.7
	20	0.3
	1	0.6
CA_1-7-20-42	7	0.7
	20	0.4
	42	0.8
	1	0.6
CA_1-7-28-40	7	0.8
	28	0.6
	40	0.9
	1	0.3
CA_1-8-11-28 <sup>11</sup>	8	0.6
	11	0.4
	28	0.6
	1	0.3
CA_1-8-11-42	8	0.6
	11	0.4
	42	0.8
	1	0.3
CA_1-8-20-28	8	0.6
	20	0.6
	28	0.6
	1	0.3
CA_1-19-21-42	19	0.3
	21	0.4
	42	0.8
	1	0.5
CA_1-20-32-42	20	0.4
	42	0.8
	1	0.5
CA_1-20-32-43	20	0.3
	43	0.8

CA_1-21-28-42	1	0.3
	21	0.4
	28	0.6
	42	0.8
CA_1-32-42-43 <sup>13</sup>	1	0.5
	42	0.8
	43	0.8
CA_2-4-5-12	2	0.5
	4	0.5
	5	0.8
	12	0.8
CA_2-4-5-29	2	0.5
	4	0.5
	5	0.5
CA_2-4-5-30	2	0.5
	4	0.5
	5	0.3
	30	0.3
	30	0.3
CA_2-4-7-12	2	0.5
	4	0.5
	7	0.5
	12	0.8
CA_2-4-12-30	2	0.5
	4	0.5
	12	0.8
	30	0.3
CA_2-4-29-30	2	0.5
	4	0.5
	30	0.3
CA_2-5-7-28	2	0.5
	5	0.6
	7	0.6
	28	0.6
CA_2-5-12-66, CA_2-2-5-12-66	2	0.5
	5	0.8
	12	0.5
CA_2-5-30-66, CA_2-2-5-30-66, CA_2-5-30-66-66	66	0.8
	2	0.5
	5	0.3
	30	0.3
CA_2-5-46-66, CA_2-5-46-66-66	66	0.5
	2	0.5
	5	0.3
	66	0.5
CA_2-7-46-66	2	0.5
	7	0.5
	46	0
	66	0.5



CA_2-7-13-66	2	0.5
	7	0.5
	13	0.3
	66	0.5
CA_2-7-26-66	2	0.5
	7	0.5
	26	0.3
	66	0.5
CA_2-12-30-66, CA_2-2-12-30-66, CA_2-12-30-66-66	2	0.5
	12	0.8
	30	0.3
	66	0.5
CA_2-13-46-66, CA_2-13-46-66-66	2	0.5
	13	0.3
	66	0.5
CA_2-13-48-66, CA_2-13-48-48-66	2	0.6
	13	0.3
	48	0.8
	66	0.6
CA_2-14-30-66, CA_2-2-14-30-66, CA_2-14-30-66-66	2	0.5
	14	0.3
	30	0.3
	66	0.5
CA_2-7-12-66, CA_2- 2-7-12-66	2	0.5
	7	0.5
	12	0.8
	66	0.5
CA_2-7-29-66, CA_2- 7-7-29-66	2	0.5
	7	0.5
	66	0.5
CA_2-29-30-66	2	0.5
	30	0.3
	66	0.5
CA_2-46-48-66	2	0.6
	48	0.8
	66	0.6
CA_3-5-7-28, CA_3- 3-5-7-28	3	0.5
	5	0.5
	7	0.5
	28	0.5
CA_3-7-8-20	3	0.5
	7	0.5
	8	0.4
	20	0.4
CA_3-7-8-38	3	0.5
	7	0.5
	8	0.5
CA_3-7-8-40	38	0.5
	3	0.6
	7	0.8
	8	0.6
CA_3-7-20-28	40	0.9
	3	0.5
	7	0.5
	20	0.6
CA_3-7-20-32	28	0.5
	3	0.7
	7	0.7
	20	0.3
CA_3-7-20-42	3	0.6
	7	0.6
	20	0.3
	42	0.8
CA_3-7-28-38	3	0.5
	7	0.5

	28	0.5
	38	0.5
CA_3-7-28-40	3	0.6
	7	0.8
	28	0.3
	40	0.9
CA_3-7-32-46	3	0.7
	7	0.7
CA_3-8-11-28 <sup>12</sup>	3	0.8
	8	0.6
	11	0.9
	28	0.6
CA_3-8-20-28	3	0.3
	8	0.6
	20	0.5
	28	0.5
CA_3-19-21-42	3	0.8
	19	0.3
	21	0.9
	42	0.8
CA_3-20-32-42	3	0.6
	20	0.4
	42	0.8
CA_3-20-32-43	3	0.5
	20	0.3
	43	0.8
CA_3-21-28-42	3	0.8
	21	0.9
	28	0.5
	42	0.8
CA_3-28-41-42	3	1
	28	0.5
	41	0.3/0.8 <sup>8</sup>
	42	0.8
CA_3-32-42-43 <sup>13</sup>	3	0.6
	42	0.8
	43	0.8

NOTE 1:	The above additional tolerances are only applicable for the E-UTRA operating bands that belong to the supported inter-band carrier aggregation configurations.
NOTE 2:	The above additional tolerances also apply in non-aggregated operation for the supported E-UTRA operating bands that belong to the supported inter-band carrier aggregation configurations.
NOTE 3:	Tolerances for a UE supporting multiple 4DL inter-band CA configurations are FFS.
NOTE 4:	The above additional tolerances applicable for the E-UTRA operating bands that belong to the supported highest order inter-band carrier aggregation configuration, also applies to the same E-UTRA operating bands that belong to a supported lower order CA configuration.
NOTE 5:	For UE supporting E-UTRA band 65 and CA configurations including Band 1, the Band 65 $\Delta T_{IB,c}$ is the max(Band 65 $\Delta T_{IB,c}$ , Band 1 $\Delta T_{IB,c}$ ).
NOTE 6:	For UE supporting E-UTRA band 42, 43 or 48 and CA configurations including Band 42, 43 or 48, the applicable $\Delta T_{IB,c}$ in Band 42, 43, or 48 is the max(Band 42 $\Delta T_{IB,c}$ , Band 43 $\Delta T_{IB,c}$ , Band 48 $\Delta T_{IB,c}$ ).
NOTE 7:	The requirement is applied for UE transmitting on the frequency range of 2545-2690MHz.
NOTE 8:	The requirement is applied for UE transmitting on the frequency range of 2496-2545MHz.
NOTE 9:	The values in the table reflect what can be achieved with the present state of the art technology. They shall be reconsidered when the state of the art technology progresses.
NOTE 10:	Only applicable for UE supporting inter-band carrier aggregation with the uplink active in Band 1, Band 3 or Band 8.
NOTE 11:	Only applicable for UE supporting inter-band carrier aggregation with the uplink active in Band 1, Band 8 or Band 11.
NOTE 12:	Only applicable for UE supporting inter-band carrier aggregation with the uplink active in Band 3, Band 8 or Band 11.
NOTE 13:	Applicable for UE supporting inter-band carrier aggregation without simultaneous Rx/Tx among TDD bands.

Table 6.2.5-5:  $\Delta T_{IB,c}$  (five bands)

E-UTRA operating band combination	E-UTRA Band	$\Delta T_{IB,c}$ [dB]
CA_1-3-5-7-28	1	0.6
	3	0.6
	5	0.5
	7	0.6
	28	0.6
CA_1-3-7-8-20	1	0.6
	3	0.6
	7	0.6
	8	0.6
	20	0.6
CA_1-3-7-20-28	1	0.6
	3	0.6
	7	0.6
	20	0.6
	28	0.6
CA_1-3-7-20-32	1	0.7
	3	0.7
	7	0.7
	20	0.3

CA_1-3-7-20-42	1	0.7
	3	0.7
	7	0.7
	20	0.3
	42	0.8
CA_1-3-8-11-28	1	0.3
	3	0.8
	8	0.6
	11	0.9
	28	0.6
CA_1-3-20-32-42	1	0.6
	3	0.6
	20	0.4
	42	0.8
CA_1-3-20-32-43	1	0.5
	3	0.5
	20	0.3
	43	0.8
CA_1-3-32-42-43	1	0.6
	3	0.6
	42	0.8
	43	0.8
NOTE 1: The above additional tolerances are only applicable for the E-UTRA operating bands that belong to the supported inter-band carrier aggregation configurations.		
NOTE 2: The above additional tolerances also apply in non-aggregated operation for the supported E-UTRA operating bands that belong to the supported inter-band carrier aggregation configurations.		
NOTE 3: Tolerances for a UE supporting multiple 5DL inter-band CA configurations are FFS.		
NOTE 4: The above additional tolerances applicable for the E-UTRA operating bands that belong to the supported highest order inter-band carrier aggregation configuration, also applies to the same E-UTRA operating bands that belong to a supported lower order CA configuration.		

NOTE: The above additional tolerances do not apply to supported UTRA operating bands with frequency range below 1 GHz that correspond to the E-UTRA operating bands that belong to the supported inter-band carrier aggregation configurations when such bands are belonging only to band combination(s) where one band is <1GHz and other bands are >1.7GHz and there is no harmonic relationship between the low band UL and high band DL. Otherwise the above additional tolerances also apply to supported UTRA operating bands that correspond to the E-UTRA operating bands that belong to the supported inter-band carrier aggregation configurations.

## 6.2.5A Configured transmitted power for CA

For uplink carrier aggregation the UE is allowed to set its configured maximum output power  $P_{\text{CMAX},c}$  for serving cell  $c$  and its total configured maximum output power  $P_{\text{CMAX}}$ .

The configured maximum output power  $P_{\text{CMAX},c}$  on serving cell  $c$  shall be set as specified in subclause 6.2.5.

For uplink inter-band carrier aggregation,  $\text{MPR}_c$  and  $\text{A-MPR}_c$  apply per serving cell  $c$  and are specified in subclause 6.2.3 and subclause 6.2.4, respectively.  $\text{P-MPR}_c$  accounts for power management for serving cell  $c$ .  $P_{\text{CMAX},c}$  is calculated under the assumption that the transmit power is increased independently on all component carriers.

For uplink intra-band contiguous and non-contiguous carrier aggregation,  $\text{MPR}_c = \text{MPR}$  and  $\text{A-MPR}_c = \text{A-MPR}$  with  $\text{MPR}$  and  $\text{A-MPR}$  specified in subclause 6.2.3A and subclause 6.2.4A respectively. There is one power management term for the UE, denoted  $\text{P-MPR}$ , and  $\text{P-MPR}_c = \text{P-MPR}$ .  $P_{\text{CMAX},c}$  is calculated under the assumption that the transmit power is increased by the same amount in dB on all component carriers.

The total configured maximum output power  $P_{\text{CMAX}}$  shall be set within the following bounds:

$$P_{\text{CMAX}_L} \leq P_{\text{CMAX}} \leq P_{\text{CMAX}_H}$$

For uplink inter-band carrier aggregation with one serving cell  $c$  per operating band when same TTI pattern is used in all aggregated serving cells,

$$P_{\text{CMAX}_L} = \text{MIN} \{ 10 \log_{10} \sum \text{MIN} [ p_{\text{EMAX}_c} / (\Delta T_{C,c}), p_{\text{PowerClass}} / (\text{mpr}_c \cdot a\text{-mpr}_c \cdot \Delta T_{C,c} \cdot \Delta t_{\text{IB},c} \cdot \Delta t_{\text{ProSe}}), p_{\text{PowerClass}} / \text{pmpr}_c ], p_{\text{PowerClass}} \}$$

$$P_{\text{CMAX}_H} = \text{MIN} \{ 10 \log_{10} \sum p_{\text{EMAX}_c}, p_{\text{PowerClass}} \}$$

where

- $p_{\text{EMAX}_c}$  is the linear value of  $P_{\text{EMAX}_c}$  which is given by IE *P-Max* for serving cell  $c$  in [7];
- $P_{\text{PowerClass}}$  is the maximum UE power specified in Table 6.2.2A-1 without taking into account the tolerance specified in the Table 6.2.2A-1;  $p_{\text{PowerClass}}$  is the linear value of  $P_{\text{PowerClass}}$ ;
- $\text{mpr}_c$  and  $a\text{-mpr}_c$  are the linear values of MPR $_c$  and A-MPR $_c$  as specified in subclause 6.2.3 and subclause 6.2.4, respectively;
- $\text{pmpr}_c$  is the linear value of P-MPR $_c$ ;
- $\Delta T_{C,c}$  is the linear value of  $\Delta T_{C,c}$ ,  $\Delta T_{C,c} = 1.41$  when NOTE 2 in Table 6.2.2-1 applies for a serving cell  $c$ , otherwise  $\Delta T_{C,c} = 1$ ;
- $\Delta t_{\text{IB},c}$  is the linear value of the inter-band relaxation term  $\Delta T_{\text{IB},c}$  of the serving cell  $c$  as specified in Table 6.2.5-2; otherwise  $\Delta t_{\text{IB},c} = 1$ ;
- $\Delta t_{\text{ProSe}}$  is the linear value of  $\Delta T_{\text{ProSe}}$  and applies as specified in subclause 6.2.5.

For uplink intra-band contiguous and non-contiguous carrier aggregation when same TTI pattern is used in all aggregated serving cells,

$$P_{\text{CMAX}_L} = \text{MIN} \{ 10 \log_{10} \sum p_{\text{EMAX}_c} - \Delta T_C, (P_{\text{PowerClass}} - \Delta P_{\text{PowerClass}}) - \text{MAX}(\text{MPR} + \text{A-MPR} + \Delta T_{\text{IB},c} + \Delta T_C + \Delta T_{\text{ProSe}}, \text{P-MPR}) \}$$

$$P_{\text{CMAX}_H} = \text{MIN} \{ 10 \log_{10} \sum p_{\text{EMAX}_c}, p_{\text{PowerClass}} \}$$

where

- $p_{\text{EMAX}_c}$  is the linear value of  $P_{\text{EMAX}_c}$  which is given by IE *P-Max* for serving cell  $c$  in [7];
- $P_{\text{PowerClass}}$  is the maximum UE power specified in Table 6.2.2A-1 without taking into account the tolerance specified in the Table 6.2.2A-1;
- $\Delta P_{\text{PowerClass}} = 3$  dB for a power class 2 capable UE operating in Band 41, when *P-max* of 23 dBm or lower is indicated or if the uplink/downlink configuration is 0 or 6 in the cell; otherwise,  $\Delta P_{\text{PowerClass}} = 0$  dB
- MPR and A-MPR are specified in subclause 6.2.3A and subclause 6.2.4A respectively;
- $\Delta T_{\text{IB},c}$  is the additional tolerance for serving cell  $c$  as specified in Table 6.2.5-2;
- P-MPR is the power management term for the UE;
- $\Delta T_C$  is the highest value  $\Delta T_{C,c}$  among all serving cells  $c$  in the  $T_{\text{REF}}$  over all  $T_{\text{eval}}$  durations.  $\Delta T_{C,c} = 1.5$  dB when NOTE 2 in Table 6.2.2A-1 applies to the serving cell  $c$ , otherwise  $\Delta T_{C,c} = 0$  dB;
- $\Delta T_{\text{ProSe}}$  applies as specified in subclause 6.2.5.

For uplink inter-band carrier aggregation with one serving cell  $c$  per operating band when at least one different TTI patterns is used in aggregated cells, the UE is allowed to set its configured maximum output power  $P_{\text{CMAX},c(i),j}$  for serving cell  $c(i)$  of TTI length  $i$ ,  $i = 1,2,3$  and its total configured maximum output power  $P_{\text{CMAX}}$ .

The configured maximum output power  $P_{\text{CMAX},c(i),j}(p)$  in TTI  $p$  of serving cell  $c(i)$  on TTI length  $i$  shall be set within the following bounds:

$$P_{\text{CMAX}_L,c(i),j}(p) \leq P_{\text{CMAX},c(i),j}(p) \leq P_{\text{CMAX}_H,c(i),j}(p)$$

where  $P_{\text{CMAX\_L},c(i),j}(p)$  and  $P_{\text{CMAX\_H},c(i),j}(p)$  are the limits for a serving cell  $c(i)$  of TTI length  $i$  as specified in subclause 6.2.5.

The total UE configured maximum output power  $P_{\text{CMAX}}(p,q,k)$  in a TTI  $p$  of TTI length 1, a TTI  $q$  of TTI length 2 and a TTI  $k$  of TTI length 3 that overlap in time shall be set within the following bounds unless stated otherwise:

$$P_{\text{CMAX\_L}}(p,q,k) \leq P_{\text{CMAX}}(p,q,k) \leq P_{\text{CMAX\_H}}(p,q,k)$$

When  $p, q, k$  are of different lengths and belong to different cells:

$$P_{\text{CMAX\_L}}(p,q,k) = \text{MIN} \{10 \log_{10} [P_{\text{CMAX\_L},c(1),1}(p) + P_{\text{CMAX\_L},c(2),2}(q) + P_{\text{CMAX\_L},c(3),3}(k)], P_{\text{PowerClass}}\}$$

$$P_{\text{CMAX\_H}}(p,q,k) = \text{MIN} \{10 \log_{10} [P_{\text{CMAX\_H},c(1),1}(p) + P_{\text{CMAX\_H},c(2),2}(q) + P_{\text{CMAX\_H},c(3),3}(k)], P_{\text{PowerClass}}\}$$

where  $P_{\text{CMAX\_L},c(i),j}$  and  $P_{\text{CMAX\_H},c(i),j}$  are the respective limits  $P_{\text{CMAX\_L},c(i),j}$  and  $P_{\text{CMAX\_H},c(i),j}$  expressed in linear scale.

For combinations of intra-band and inter-band carrier aggregation with UE configured for transmission on three serving cells (up to two contiguously aggregated carriers per operating band),

For the case when  $p$  and  $q$  belong to the same band and  $k$  belongs to a different band but  $p, q$  and  $k$  are of the same TTI pattern.

$$P_{\text{CMAX\_L}} = \text{MIN} \{10 \log_{10} \sum (P_{\text{CMAX\_L}, Bi}), P_{\text{PowerClass}}\}$$

$$P_{\text{CMAX\_H}} = \text{MIN} \{10 \log_{10} \sum P_{\text{EMAX}, c}, P_{\text{PowerClass}}\}$$

For the case when  $p$  and  $q$  belong to the same band and are of the same TTI pattern while  $k$  belong to a different band and is of different TTI pattern then:

$$P_{\text{CMAX\_L}}(p,q,k) = \text{MIN} \{10 \log_{10} [P_{\text{CMAX\_L}, Bi}(p) + P_{\text{CMAX\_L}, c(3),3}(k)], P_{\text{PowerClass}}\}$$

$$P_{\text{CMAX\_H}}(p,q,k) = \text{MIN} \{10 \log_{10} [P_{\text{CMAX\_H}, Bi}(p) + P_{\text{CMAX\_H}, c(3),3}(k)], P_{\text{PowerClass}}\}$$

where

- $P_{\text{EMAX}, c}$  is the linear value of  $P_{\text{EMAX}, c}$  which is given by IE *P-Max* for serving cell  $c$  in [7];
- $P_{\text{PowerClass}}$  is the maximum UE power specified in Table 6.2.2A-0 without taking into account the tolerance specified in the Table 6.2.2A-0;  $p_{\text{PowerClass}}$  is the linear value of  $P_{\text{PowerClass}}$ ;
- $P_{\text{CMAX\_L}, Bi}$  is the linear values of  $P_{\text{CMAX\_L}}$  as specified in corresponding operating band.  $P_{\text{CMAX\_L}, c}$  specified for single carrier in subclause 6.2.5 applies for operating band supporting one serving cell.  $P_{\text{CMAX\_L}}$  specified for uplink intra-band contiguous carrier aggregation in subclause 6.2.5A applies for operating band supporting two contiguous serving cells.
- intra-band carriers use the same TTI patterns.

$T_{\text{REF}}$  and  $T_{\text{eval}}$  are specified in Table 6.2.5A-0 when same and different TTI patterns are used in aggregated carriers. For each  $T_{\text{REF}}$ , the  $P_{\text{CMAX\_L}}$  is evaluated per  $T_{\text{eval}}$  and given by the minimum value taken over the transmission(s) within the  $T_{\text{eval}}$ ; the minimum  $P_{\text{CMAX\_L}}$  over the one or more  $T_{\text{eval}}$  is then applied for the entire  $T_{\text{REF}}$ .  $P_{\text{PowerClass}}$  shall not be exceeded by the UE during any period of time.

**Table 6.2.5A-0:  $P_{\text{CMAX}}$  evaluation window for different TTI patterns**

TTI duration	$T_{\text{REF}}$	$T_{\text{eval}}$
Different TTI duration in different aggregated carrier	$T_{\text{REF}}$ of longer TTI	$T_{\text{eval}}$ of shortest TTI

If the UE is configured with multiple TAGs and transmissions of the UE on TTI  $i$  for any serving cell in one TAG overlap some portion of the first symbol of the transmission on TTI  $i+1$  for a different serving cell in another TAG, the UE minimum of  $P_{\text{CMAX\_L}}$  for TTIs  $i$  and  $i+1$  applies for any overlapping portion of TTIs  $i$  and  $i+1$ .  $P_{\text{PowerClass}}$  shall not be exceeded by the UE during any period of time.

In case PC2 and uplink intra-band contiguous CA capable UE receives  $p_{\text{EMAX}, c}$  in Scell then that applies both to Scell and Pcell once the Scell is activated.

The measured maximum output power  $P_{UMAX}$  over all serving cells with same TTI pattern shall be within the following range:

$$P_{CMAX,L} - \text{MAX}\{T_L, T_{LOW}(P_{CMAX,L})\} \leq P_{UMAX} \leq P_{CMAX,H} + T_{HIGH}(P_{CMAX,H})$$

$$P_{UMAX} = 10 \log_{10} \sum P_{UMAX,c}$$

where  $P_{UMAX,c}$  denotes the measured maximum output power for serving cell  $c$  expressed in linear scale. The tolerances  $T_{LOW}(P_{CMAX})$  and  $T_{HIGH}(P_{CMAX})$  for applicable values of  $P_{CMAX}$  are specified in Table 6.2.5A-1 and Table 6.2.5A-2 for inter-band carrier aggregation and intra-band carrier aggregation, respectively. The tolerance  $T_L$  is the absolute value of the lower tolerance for applicable E-UTRA CA configuration as specified in Table 6.2.2A-0, Table 6.2.2A-1 and Table 6.2.2A-2 for inter-band carrier aggregation, intra-band contiguous carrier aggregation and intra-band non-contiguous carrier aggregation, respectively.

The measured maximum output power  $P_{UMAX}$  over all serving cells, when atleast one TTI has a different TTI pattern, shall be within the following range:

$$P'_{CMAX,L} - \text{MAX}\{T_L, T_{LOW}(P'_{CMAX,L})\} \leq P'_{UMAX} \leq P'_{CMAX,H} + T_{HIGH}(P'_{CMAX,H})$$

$$P'_{UMAX} = 10 \log_{10} \sum p'_{UMAX,c}$$

where  $p'_{UMAX,c}$  denotes the average measured maximum output power for serving cell  $c$  expressed in linear scale over  $T_{REF}$ . The tolerances  $T_{LOW}(P'_{CMAX})$  and  $T_{HIGH}(P'_{CMAX})$  for applicable values of  $P'_{CMAX}$  are specified in Table 6.2.5A-1 and Table 6.2.5A-2 for inter-band carrier aggregation and intra-band carrier aggregation, respectively. The tolerance  $T_L$  is the absolute value of the lower tolerance for applicable E-UTRA CA configuration as specified in Table 6.2.2A-0, Table 6.2.2A-1 and Table 6.2.2A-2 for inter-band carrier aggregation, intra-band contiguous carrier aggregation and intra-band non-contiguous carrier aggregation, respectively.

where:

$$P'_{CMAX,L} = \text{MIN}\{ \text{MIN}\{10 \log_{10} \sum (p_{CMAX,L,B}), P_{PowerClass}\} \text{ over all overlapping TTIs in } T_{REF}\}$$

$$P'_{CMAX,H} = \text{MAX}\{ \text{MIN}\{10 \log_{10} \sum p_{EMAX,c}, P_{PowerClass}\} \text{ over all overlapping TTIs in } T_{REF}\}$$

**Table 6.2.5A-1:  $P_{CMAX}$  tolerance for uplink inter-band CA (two bands)**

$P_{CMAX}$ (dBm)	Tolerance $T_{LOW}(P_{CMAX})$ (dB)	Tolerance $T_{HIGH}(P_{CMAX})$ (dB)
$P_{CMAX} = 23$	3.0	2.0
$22 \leq P_{CMAX} < 23$	5.0	2.0
$21 \leq P_{CMAX} < 22$	5.0	3.0
$20 \leq P_{CMAX} < 21$	6.0	4.0
$16 \leq P_{CMAX} < 20$	5.0	
$11 \leq P_{CMAX} < 16$	6.0	
$-40 \leq P_{CMAX} < 11$	7.0	

**Table 6.2.5A-2:  $P_{CMAX}$  tolerance for uplink intra-band CA**

$P_{CMAX}$ (dBm)	Tolerance $T_{LOW}(P_{CMAX})$ (dB)	Tolerance $T_{HIGH}(P_{CMAX})$ (dB)
$21 \leq P_{CMAX} \leq 26$	2.0	
$20 \leq P_{CMAX} < 21$	2.5	
$19 \leq P_{CMAX} < 20$	3.5	
$18 \leq P_{CMAX} < 19$	4.0	
$13 \leq P_{CMAX} < 18$	5.0	
$8 \leq P_{CMAX} < 13$	6.0	
$-40 \leq P_{CMAX} < 8$	7.0	

## 6.2.5B Configured transmitted power for UL-MIMO

For UE supporting UL-MIMO, the transmitted power is configured per each UE.

The definitions of configured maximum output power  $P_{\text{CMAX},c}$ , the lower bound  $P_{\text{CMAX}_L,c}$ , and the higher bound  $P_{\text{CMAX}_H,c}$  specified in subclause 6.2.5 shall apply to UE supporting UL-MIMO, where

- $P_{\text{PowerClass}}$ ,  $\Delta P_{\text{PowerClass}}$  and  $\Delta T_{C,c}$  are specified in subclause 6.2.2B;
- $MPR_c$  is specified in subclause 6.2.3B;
- $A\text{-}MPR_c$  is specified in subclause 6.2.4B.

The measured configured maximum output power  $P_{\text{UMAX},c}$  for serving cell  $c$  shall be within the following bounds:

$$P_{\text{CMAX}_L,c} - \text{MAX}\{T_L, T_{\text{LOW}}(P_{\text{CMAX}_L,c})\} \leq P_{\text{UMAX},c} \leq P_{\text{CMAX}_H,c} + T_{\text{HIGH}}(P_{\text{CMAX}_H,c})$$

where  $T_{\text{LOW}}(P_{\text{CMAX}_L,c})$  and  $T_{\text{HIGH}}(P_{\text{CMAX}_H,c})$  are defined as the tolerance and applies to  $P_{\text{CMAX}_L,c}$  and  $P_{\text{CMAX}_H,c}$  separately, while  $T_L$  is the absolute value of the lower tolerance in Table 6.2.2B-1 for the applicable operating band.

For UE with two transmit antenna connectors in closed-loop spatial multiplexing scheme, the tolerance is specified in Table 6.2.5B-1. The requirements shall be met with UL-MIMO configurations specified in Table 6.2.2B-2.

**Table 6.2.5B-1:  $P_{\text{CMAX},c}$  tolerance in closed-loop spatial multiplexing scheme**

$P_{\text{CMAX},c}$ (dBm)	Tolerance $T_{\text{LOW}}(P_{\text{CMAX}_L,c})$ (dB)	Tolerance $T_{\text{HIGH}}(P_{\text{CMAX}_H,c})$ (dB)
$P_{\text{CMAX},c} = 23$	3.0	2.0
$22 \leq P_{\text{CMAX},c} < 23$	5.0	2.0
$21 \leq P_{\text{CMAX},c} < 22$	5.0	3.0
$20 \leq P_{\text{CMAX},c} < 21$	6.0	4.0
$16 \leq P_{\text{CMAX},c} < 20$	5.0	
$11 \leq P_{\text{CMAX},c} < 16$	6.0	
$-40 \leq P_{\text{CMAX},c} < 11$	7.0	

If UE is configured for transmission on single-antenna port, the requirements in subclause 6.2.5 apply.

## 6.2.5C Configured transmitted power for Dual Connectivity

For inter-band dual connectivity with one uplink serving cell per CG, the UE is allowed to set its configured maximum output power  $P_{\text{CMAX},c(i),j}$  for serving cell  $c(i)$  of CG  $i$ ,  $i = 1, 2$ , and its total configured maximum output power  $P_{\text{CMAX}}$ .

The configured maximum output power  $P_{\text{CMAX},c(i),j}(p)$  in subframe  $p$  of serving cell  $c(i)$  on CG  $i$  shall be set within the following bounds:

$$P_{\text{CMAX}_L,c(i),j}(p) \leq P_{\text{CMAX},c(i),j}(p) \leq P_{\text{CMAX}_H,c(i),j}(p)$$

where  $P_{\text{CMAX}_L,c(i),j}(p)$  and  $P_{\text{CMAX}_H,c(i),j}(p)$  are the limits for a serving cell  $c(i)$  of CG  $i$  as specified in subclause 6.2.5.

The total UE configured maximum output power  $P_{\text{CMAX}}(p,q)$  in a subframe  $p$  of CG 1 and a subframe  $q$  of CG 2 that overlap in time shall be set within the following bounds for synchronous and asynchronous operation unless stated otherwise:

$$P_{\text{CMAX}_L}(p,q) \leq P_{\text{CMAX}}(p,q) \leq P_{\text{CMAX}_H}(p,q)$$

with

$$P_{\text{CMAX}_L}(p,q) = \text{MIN} \{10 \log_{10} [p_{\text{CMAX}_L,c(1),j}(p) + p_{\text{CMAX}_L,c(2),j}(q)], P_{\text{PowerClass}}\}$$

$$P_{\text{CMAX}_H}(p,q) = \text{MIN} \{10 \log_{10} [p_{\text{CMAX}_H,c(1),j}(p) + p_{\text{CMAX}_H,c(2),j}(q)], P_{\text{PowerClass}}\}$$

where  $p_{\text{CMAX}_L,c(i),j}$  is  $p_{\text{CMAX}_H,c(i),j}$  are the respective limits  $P_{\text{CMAX}_L,c(i),j}(p)$  and  $P_{\text{CMAX}_H,c(i),j}(p)$  expressed in linear scale.



If the UE is configured in Dual Connectivity and synchronous transmissions of the UE on subframe  $p$  for a serving cell in one CG overlaps some portion of the first symbol of the transmission on subframe  $q + I$  for a different serving cell in the other CG, the UE minimum of  $P_{\text{CMAX}_L}$  between subframes pairs  $(p, q)$  and  $(p+I, q+I)$  respectively applies for any overlapping portion of subframes  $(p, q)$  and  $(p+I, q+I)$ .  $P_{\text{PowerClass}}$  shall not be exceeded by the UE during any period of time.

The measured total maximum output power  $P_{\text{UMAX}}$  over both CGs is

$$P_{\text{UMAX}} = 10 \log_{10} [P_{\text{UMAX},c(1),I} + P_{\text{UMAX},c(2),I}],$$

where  $P_{\text{UMAX},c(i),I}$  denotes the measured output power of serving cell  $c(i)$  of CG  $i$  expressed in linear scale.

If the UE is configured in Dual Connectivity and synchronous transmissions

$$P_{\text{CMAX}_L}(p, q) - T_{\text{LOW}}(P_{\text{CMAX}_L}(p, q)) \leq P_{\text{UMAX}} \leq P_{\text{CMAX}_H}(p, q) + T_{\text{HIGH}}(P_{\text{CMAX}_H}(p, q))$$

where  $P_{\text{CMAX}_L}(p, q)$  and  $P_{\text{CMAX}_H}(p, q)$  are the limits for the pair  $(p, q)$  and with the tolerances  $T_{\text{LOW}}(P_{\text{CMAX}})$  and  $T_{\text{HIGH}}(P_{\text{CMAX}})$  for applicable values of  $P_{\text{CMAX}}$  specified in Table 6.2.5C-1.  $P_{\text{CMAX}_L}$  may be modified for any overlapping portion of subframes  $(p, q)$  and  $(p+I, q+I)$ .

If the UE is configured in Dual Connectivity and asynchronous transmissions, the subframes of the leading CG are taken as reference subframes for the measurement of the total configured output power  $P_{\text{UMAX}}$ . If subframe  $p$  of CG 1 and subframe  $q$  of CG 2 overlap in time in their respective slot 0 and

1. if  $p$  leads in time over  $q$ , then  $p$  is the reference subframe and the  $(p, q)$  and  $(p, q-I)$  pairs are considered for determining the  $P_{\text{CMAX}}$  tolerance
2. if  $q$  leads in time over  $p$ , then  $q$  is the reference subframe and the  $(p-I, q)$  and  $(p, q)$  pairs are considered for determining the  $P_{\text{CMAX}}$  tolerance;

for the reference subframe  $p$  duration (when subframe  $p$  in CG 1 leads):

$$P'_{\text{CMAX}_L} = \text{MIN} \{P_{\text{CMAX}_L}(p, q), P_{\text{CMAX}_L}(p, q-I)\}$$

$$P'_{\text{CMAX}_H} = \text{MAX} \{P_{\text{CMAX}_H}(p, q), P_{\text{CMAX}_H}(p, q-I)\}$$

while for the reference subframe  $q$  duration (when subframe  $q$  in CG 2 leads):

$$P'_{\text{CMAX}_L} = \text{MIN} \{P_{\text{CMAX}_L}(p-I, q), P_{\text{CMAX}_L}(p, q)\}$$

$$P'_{\text{CMAX}_H} = \text{MAX} \{P_{\text{CMAX}_H}(p-I, q), P_{\text{CMAX}_H}(p, q)\}$$

where  $P_{\text{CMAX}_L}$  and  $P_{\text{CMAX}_H}$  are the applicable limits for each overlapping subframe pairs  $(p, q)$ ,  $(p, q-I)$  and  $(p-I, q)$ . The measured total configured maximum output power  $P_{\text{UMAX}}$  shall be within the following bounds:

$$P'_{\text{CMAX}_L} - T_{\text{LOW}}(P'_{\text{CMAX}_L}) \leq P_{\text{UMAX}} \leq P'_{\text{CMAX}_H} + T_{\text{HIGH}}(P'_{\text{CMAX}_H})$$

with the tolerances  $T_{\text{LOW}}(P_{\text{CMAX}})$  and  $T_{\text{HIGH}}(P_{\text{CMAX}})$  for applicable values of  $P_{\text{CMAX}}$  specified in Table 6.2.5C-1.

**Table 6.2.5C-1:  $P_{\text{CMAX}}$  tolerance for inter-band Dual Connectivity**

$P_{\text{CMAX}}(\text{dBm})$	Tolerance $T_{\text{LOW}}(P_{\text{CMAX}_L})(\text{dB})$	Tolerance $T_{\text{HIGH}}(P_{\text{CMAX}_H})(\text{dB})$
$P_{\text{CMAX}} = 23$	3.0	2.0
$22 \leq P_{\text{CMAX}} < 23$	5.0	2.0
$21 \leq P_{\text{CMAX}} < 22$	5.0	3.0
$20 \leq P_{\text{CMAX}} < 21$	6.0	4.0
$16 \leq P_{\text{CMAX}} < 20$		5.0
$11 \leq P_{\text{CMAX}} < 16$		6.0
$-40 \leq P_{\text{CMAX}} < 11$		7.0

## 6.2.5D Configured transmitted power for ProSe

When UE is configured for E-UTRA ProSe sidelink transmissions non-concurrent with E-UTRA uplink transmissions for E-UTRA ProSe operating bands specified in Table 5.5D-1, the configured maximum output power  $P_{\text{CMAX},c}$  and power boundary requirement specified in subclause 6.2.5 shall apply to UE supporting ProSe, where

- $\text{MPR}_c$  is specified in subclause 6.2.3D;
- A- $\text{MPR}_c$  is specified in subclause 6.2.4D;
- $\Delta T_{\text{ProSe}} = 0.1$  dB.

For  $P_{\text{CMAX},\text{PSSCH}}$  and  $P_{\text{CMAX},\text{PSCCH}}$ ,  $P_{\text{EMAX},c}$  is the value given by IE *P-Max* for serving cell  $c$ , defined by [7], when present.  $P_{\text{EMAX},c}$  is the value given by IE *maxTxPower*, defined by [7], when the UE is not associated with a serving cell on the ProSe carrier.

For  $P_{\text{CMAX},\text{PSSDCH}}$ ,  $P_{\text{EMAX},c}$  is the value given by the IE *discMaxTxPower* in [7].

For  $P_{\text{CMAX},\text{PSBCH}}$ ,  $P_{\text{EMAX},c}$  is the value given by the IE *maxTxPower* in [7] when the ProSe UE is not associated with a serving cell on the ProSe carrier. When the UE is associated with a serving cell, then  $P_{\text{EMAX},c}$  is the value given by the IE *P-Max* when PSBCH/SLSS transmissions is triggered for ProSe Direct communication as specified in [7], and is the value given by the IE *discMaxTxPower* in [7] otherwise.

For  $P_{\text{CMAX},\text{SSSS}}$ , the value is as calculated for  $P_{\text{CMAX},\text{PSBCH}}$  and applying the MPR for SSSS as specified in Section 6.2.3D.

When a UE is configured for simultaneous E-UTRA ProSe sidelink and E-UTRA uplink transmissions for inter-band E-UTRA ProSe / E-UTRA bands specified in Table 5.5D-2, the UE is allowed to set its configured maximum output power  $P_{\text{CMAX},c,\text{E-UTRA}}$  and  $P_{\text{CMAX},c,\text{ProSe}}$  for the configured E-UTRA uplink carrier and the configured E-UTRA ProSe carrier, respectively, and its total configured maximum output power  $P_{\text{CMAX},c}$ .

The configured maximum output power  $P_{\text{CMAX},c,\text{E-UTRA}}(p)$  in subframe  $p$  for the configured E-UTRA uplink carrier shall be set within the bounds:

$$P_{\text{CMAX},\text{L},c,\text{E-UTRA}}(p) \leq P_{\text{CMAX},c,\text{E-UTRA}}(p) \leq P_{\text{CMAX},\text{H},c,\text{E-UTRA}}(p)$$

where  $P_{\text{CMAX},\text{L},c,\text{E-UTRA}}$  and  $P_{\text{CMAX},\text{H},c,\text{E-UTRA}}$  are the limits for a serving cell  $c$  as specified in subclause 6.2.5.

The configured maximum output power  $P_{\text{CMAX},c,\text{ProSe}}(q)$  in subframe  $q$  for the configured E-UTRA ProSe carrier shall be set within the bounds:

$$P_{\text{CMAX},c,\text{ProSe}}(q) \leq P_{\text{CMAX},\text{H},c,\text{ProSe}}(q)$$

where  $P_{\text{CMAX},\text{H},c,\text{ProSe}}$  is the limit as specified in subclause 6.2.5D.

The total UE configured maximum output power  $P_{\text{CMAX}}(p,q)$  in a subframe  $p$  of an E-UTRA uplink carrier and a subframe  $q$  of an E-UTRA ProSe sidelink that overlap in time shall be set within the following bounds for synchronous and asynchronous operation unless stated otherwise:

$$P_{\text{CMAX},\text{L}}(p,q) \leq P_{\text{CMAX}}(p,q) \leq P_{\text{CMAX},\text{H}}(p,q)$$

with

$$P_{\text{CMAX},\text{L}}(p,q) = P_{\text{CMAX},\text{L},c,\text{E-UTRA}}(p)$$

$$P_{\text{CMAX},\text{H}}(p,q) = \text{MIN} \{10 \log_{10} [P_{\text{CMAX},\text{H},c,\text{E-UTRA}}(p) + P_{\text{CMAX},\text{H},c,\text{ProSe}}(q)], P_{\text{PowerClass}}\}$$

where  $P_{\text{CMAX},\text{H},c,\text{ProSe}}$  and  $P_{\text{CMAX},\text{H},c,\text{E-UTRA}}$  are the limits  $P_{\text{CMAX},\text{H},c,\text{ProSe}}(q)$  and  $P_{\text{CMAX},\text{H},c,\text{E-UTRA}}(p)$  expressed in linear scale.

The measured total maximum output power  $P_{\text{UMAX}}$  over both the E-UTRA uplink and E-UTRA ProSe carriers is

$$P_{UMAX} = 10 \log_{10} [P_{UMAX,c,E-UTRA} + P_{UMAX,c,ProSe}],$$

where  $P_{UMAX,c,E-UTRA}$  denotes the measured output power of serving cell  $c$  for the configured E-UTRA uplink carrier, and  $P_{UMAX,c,ProSe}$  denotes the measured output power for the configured E-UTRA ProSe carrier expressed in linear scale.

When a UE is configured for synchronous ProSe and uplink transmissions,

$$P_{CMAX,L}(p, q) - T_{LOW}(P_{CMAX,L}(p, q)) \leq P_{UMAX} \leq P_{CMAX,H}(p, q) + T_{HIGH}(P_{CMAX,H}(p, q))$$

where  $P_{CMAX,L}(p, q)$  and  $P_{CMAX,H}(p, q)$  are the limits for the pair  $(p, q)$  and with the tolerances  $T_{LOW}(P_{CMAX})$  and  $T_{HIGH}(P_{CMAX})$  for applicable values of  $P_{CMAX}$  specified in Table 6.2.5C-1.  $P_{CMAX,L}$  may be modified for any overlapping portion of subframes  $(p, q)$  and  $(p+1, q+1)$ .

When a UE is configured for asynchronous ProSe and uplink transmissions, the carrier configured for uplink transmission is taken as the reference. If subframe  $p$  for the E-UTRA uplink carrier and subframe  $q$  for the E-UTRA ProSe carrier overlap in time and

1. if uplink carrier leads in time over  $q$ , then  $p$  is the reference subframe and, the  $(p, q)$  and  $(p, q-1)$  pairs are considered for determining the  $P_{CMAX}$  tolerance
2. if ProSe carrier leads in time over  $p$ , then  $p$  is the reference subframe and, the  $(p, q)$  and  $(p, q+1)$  pairs are considered for determining the  $P_{CMAX}$  tolerance

For the reference subframe  $p$  duration when uplink carrier leads:

$$P'_{CMAX,L} = P_{CMAX,L,c,E-UTRA}(p)$$

$$P'_{CMAX,H} = \text{MAX} \{P_{CMAX,H}(p, q-1), P_{CMAX,H}(p, q)\}$$

For the reference subframe  $p$  duration when ProSe carrier leads:

$$P'_{CMAX,L} = P_{CMAX,L,c,E-UTRA}(p)$$

$$P'_{CMAX,H} = \text{MAX} \{P_{CMAX,H}(p, q), P_{CMAX,H}(p, q+1)\}$$

where  $P_{CMAX,L,c,E-UTRA}(p)$  and  $P_{CMAX,H}$  are the applicable limits for each overlapping subframe pairs  $(p, q)$ ,  $(p, q+1)$ ,  $(p, q-1)$ . The measured total configured maximum output power  $P_{UMAX}$  shall be within the following bounds:

$$P'_{CMAX,L} - T_{LOW}(P'_{CMAX,L}) \leq P_{UMAX} \leq P'_{CMAX,H} + T_{HIGH}(P'_{CMAX,H})$$

with the tolerances  $T_{LOW}(P_{CMAX})$  and  $T_{HIGH}(P_{CMAX})$  for applicable values of  $P_{CMAX}$  specified in Table 6.2.5C-1.

## 6.2.5F Configured transmitted Power for category NB1 and NB2

For each slot  $i$  the category NB1 and NB2 UE is allowed to set its configured maximum output power  $P_{CMAX,c}$ . The configured maximum output power  $P_{CMAX,c}$  is set within the following bounds:

$$P_{CMAX,L,c} \leq P_{CMAX,c} \leq P_{CMAX,H,c}$$

Where

- $P_{CMAX,L,c} = \text{MIN} \{ P_{EMAX,c}, P_{PowerClass} - \text{MPR}_c - \text{A-MPR}_c \}$
- $P_{CMAX,H,c} = \text{MIN} \{ P_{EMAX,c}, P_{PowerClass} \}$
- $P_{EMAX,c}$  is the value given to IE *P-Max*, defined in [7]
- $P_{PowerClass}$  is the maximum category NB1 and NB2 UE power specified in Table 6.2.2F-1 without taking into account the associated tolerance
- $\text{MPR}_c$  is specified in subclause 6.2.3F
- $\text{A-MPR}_c = 0\text{dB}$  unless otherwise stated.

The measurement period for  $P_{UMAX,c}$  is at least one sub-frame (1ms) for 15 KHz channel spacing, and at least a 2ms slot (excluding the 2304Ts gap when UE is not transmitting) respectively for the 3.75 KHz channel spacing. The measured maximum output power  $P_{UMAX,c}$  shall be within the following bounds:

$$P_{CMAX,L,c} - T(P_{CMAX,L,c}) \leq P_{UMAX,c} \leq P_{CMAX,H,c} + T(P_{CMAX,H,c})$$

Where  $T(P_{CMAX})$  is defined by the tolerance table below and applies to  $P_{CMAX,L,c}$  and  $P_{CMAX,H,c}$  separately.

**Table 6.2.5F-1:  $P_{CMAX}$  tolerance for power class 3**

$P_{CMAX}$ (dBm)	Tolerance $T(P_{CMAX})$ (dB)
$21 \leq P_{CMAX} \leq 23$	2.0
$20 \leq P_{CMAX} < 21$	2.5
$19 \leq P_{CMAX} < 20$	3.5
$18 \leq P_{CMAX} < 19$	4.0
$13 \leq P_{CMAX} < 18$	5.0
$8 \leq P_{CMAX} < 13$	6.0
$-40 \leq P_{CMAX} < 8$	7.0

**Table 6.2.5F-2:  $P_{CMAX}$  tolerance for power class 5**

$P_{CMAX,c}$ (dBm)	Tolerance $T(P_{CMAX,c})$ (dB)
$18 \leq P_{CMAX,c} \leq 20$	2.0
$17 \leq P_{CMAX,c} < 18$	2.5
$16 \leq P_{CMAX,c} < 17$	3.5
$15 \leq P_{CMAX,c} < 16$	4.0
$10 \leq P_{CMAX,c} < 15$	5.0
$5 \leq P_{CMAX,c} < 10$	6.0
$-40 \leq P_{CMAX,c} < 5$	7.0

**Table 6.2.5F-3:  $P_{CMAX}$  tolerance for power class 6**

$P_{CMAX,c}$ (dBm)	Tolerance $T(P_{CMAX,c})$ (dB)
$13 \leq P_{CMAX,c} \leq 14$	2.5
$12 \leq P_{CMAX,c} < 13$	3.5
$11 \leq P_{CMAX,c} < 12$	4
$8 \leq P_{CMAX,c} < 11$	5
$5 \leq P_{CMAX,c} < 8$	6.0
$-40 \leq P_{CMAX,c} < 5$	7.0

## 6.2.5G Configured transmitted power for V2X Communication

When UE is configured for E-UTRA V2X sidelink transmissions non-concurrent with E-UTRA uplink transmissions for E-UTRA V2X operating bands specified in Table 5.5G-1, the V2X UE is allowed to set its configured maximum output power  $P_{CMAX,c}$  for component carrier  $c$ . The configured maximum output power  $P_{CMAX,c}$  is set within the following bounds:

$$P_{CMAX,L,c} \leq P_{CMAX,c} \leq P_{CMAX,H,c} \text{ with}$$

$$P_{CMAX,L,c} = \text{MIN} \{ P_{EMAX,c} - \Delta T_{C,c}, P_{PowerClass} - \text{MAX}(MPR_c + A-MPR_c + \Delta T_{IB,c} + \Delta T_{C,c} + \Delta T_{ProSe}, P-MPR_c), P_{Regulatory,c} \}$$

$$P_{CMAX,H,c} = \text{MIN} \{ P_{EMAX,c}, P_{PowerClass}, P_{Regulatory,c} \}$$

where

- For the total transmitted power  $P_{\text{CMAX},c}$  of PSSCH and PSCCH,  $P_{\text{EMAX},c}$  is the value given by IE *maxTxPower*, defined by [7], when the UE is not associated with a serving cell on the V2X carrier.
- For  $P_{\text{CMAXPSBCH}}$ ,  $P_{\text{EMAX},c}$  is the value given by the IE *maxTxPower* in [7] when the UE is not associated with a serving cell on the V2X carrier.
- For  $P_{\text{CMAXSSSS}}$ , the value is as calculated for  $P_{\text{CMAXPSBCH}}$  and applying the MPR for SSSS as specified in Section 6.2.3D.
- $P_{\text{PowerClass}}$  is the maximum UE power specified in Table 6.2.2-1 without taking into account the tolerance specified in the Table 6.2.2-1;
- $\text{MPR}_c$  and  $\text{A-MPR}_c$  for serving cell  $c$  are specified in subclause 6.2.3G and subclause 6.2.4G, respectively;
- $\Delta T_{\text{IB},c}$ ,  $\Delta T_{C,c}$ ,  $\Delta T_{\text{ProSe}}$  and  $\text{P-MPR}_c$  are specified in subclause 6.2.5
- $P_{\text{Regulatory},c} = 10 - G_{\text{post connector}}$  dBm when the V2X UE is within the protected zone [13] of CEN DSRC tolling system and operating in Band 47;  $P_{\text{Regulatory},c} = 33 - G_{\text{post connector}}$  dBm otherwise.

The maximum output power  $P_{\text{CMAX,PSSCH}}$  and  $P_{\text{CMAX,PSCCH}}$  are derived from  $P_{\text{CMAX},c}$  based on the PSD offset following subclause 14.1.1.5 in [6]. For all cases, the PSD difference between PSCCH and PSSCH shall be the same as the PSD offset value.

For the measured configured maximum output power  $P_{\text{UMAX},c}$  for E-UTRA V2X sidelink transmissions non-concurrent with E-UTRA uplink transmissions, the same requirement as in subclause 6.2.5 shall be applied.

When a UE is configured for simultaneous E-UTRA V2X sidelink and E-UTRA uplink transmissions for inter-band E-UTRA V2X / E-UTRA bands specified in Table 5.5G-2, the UE is allowed to set its configured maximum output power  $P_{\text{CMAX},c,E\text{-UTRA}}$  and  $P_{\text{CMAX},c,V2X}$  for the configured E-UTRA uplink carrier and the configured E-UTRA V2X carrier, respectively, and its total configured maximum output power  $P_{\text{CMAX},c}$ . The  $\Delta T_{\text{IB},c}$  of  $P_{\text{CMAX},c,E\text{-UTRA}}$  is specified in Table 6.2.5G-1.

The configured maximum output power  $P_{\text{CMAX},c,E\text{-UTRA}}(p)$  in subframe  $p$  for the configured E-UTRA uplink carrier shall be set within the bounds:

$$P_{\text{CMAX},L,c,E\text{-UTRA}}(p) \leq P_{\text{CMAX},c,E\text{-UTRA}}(p) \leq P_{\text{CMAX},H,c,E\text{-UTRA}}(p)$$

where  $P_{\text{CMAX},L,c,E\text{-UTRA}}$  and  $P_{\text{CMAX},H,c,E\text{-UTRA}}$  are the limits for a serving cell  $c$  as specified in subclause 6.2.5.

The configured maximum output power  $P_{\text{CMAX},c,V2X}(q)$  in subframe  $q$  for the configured E-UTRA V2X carrier shall be set within the bounds:

$$P_{\text{CMAX},c,V2X}(q) \leq P_{\text{CMAX},H,c,V2X}(q)$$

where  $P_{\text{CMAX},H,c,V2X}$  is the limit as specified in subclause 6.2.5G.

The total UE configured maximum output power  $P_{\text{CMAX}}(p,q)$  in a subframe  $p$  of an E-UTRA uplink carrier and a subframe  $q$  of an E-UTRA V2X sidelink that overlap in time shall be set within the following bounds for synchronous and asynchronous operation unless stated otherwise:

$$P_{\text{CMAX},L}(p,q) \leq P_{\text{CMAX}}(p,q) \leq P_{\text{CMAX},H}(p,q)$$

with

$$P_{\text{CMAX},L}(p,q) = P_{\text{CMAX},L,c,E\text{-UTRA}}(p)$$

$$P_{\text{CMAX},H}(p,q) = 10 \log_{10} [P_{\text{CMAX},H,c,E\text{-UTRA}}(p) + P_{\text{CMAX},H,c,V2X}(q)]$$

where  $P_{\text{CMAX},H,c,V2X}$  and  $P_{\text{CMAX},H,c,E\text{-UTRA}}$  are the limits  $P_{\text{CMAX},H,c,V2X}(q)$  and  $P_{\text{CMAX},H,c,E\text{-UTRA}}(p)$  expressed in linear scale.

The measured total maximum output power  $P_{\text{UMAX}}$  over both the E-UTRA uplink and E-UTRA V2X carriers is

$$P_{\text{UMAX}} = 10 \log_{10} [P_{\text{UMAX},c,E\text{-UTRA}} + P_{\text{UMAX},c,V2X}]$$

where  $P_{\text{UMAX},c,E\text{-UTRA}}$  denotes the measured output power of serving cell  $c$  for the configured E-UTRA uplink carrier, and  $P_{\text{UMAX},c,V2X}$  denotes the measured output power for the configured E-UTRA V2X carrier expressed in linear scale.

When a UE is configured for synchronous V2X sidelink and uplink transmissions,

$$P_{\text{CMAX}_L}(p, q) - T_{\text{LOW}}(P_{\text{CMAX}_L}(p, q)) \leq P_{\text{UMAX}} \leq P_{\text{CMAX}_H}(p, q) + T_{\text{HIGH}}(P_{\text{CMAX}_H}(p, q))$$

where  $P_{\text{CMAX}_L}(p, q)$  and  $P_{\text{CMAX}_H}(p, q)$  are the limits for the pair  $(p, q)$  and with the tolerances  $T_{\text{LOW}}(P_{\text{CMAX}})$  and  $T_{\text{HIGH}}(P_{\text{CMAX}})$  for applicable values of  $P_{\text{CMAX}}$  specified in Table 6.2.5G-2.  $P_{\text{CMAX}_L}$  may be modified for any overlapping portion of subframes  $(p, q)$  and  $(p+1, q+1)$ .

When a UE is configured for asynchronous V2X and uplink transmissions, the subframe  $p$  for the E-UTRA uplink carrier and subframe  $q$  for the E-UTRA V2X carrier overlap in time and

1. if uplink carrier leads in time over  $q$  and V2X UE sidelink transmission has SCI whose "Priority" field is set to a value less than the high layer parameter  $\text{thresSL-TxPrioritization}$ , then  $p$  is the reference subframe and the  $(p, q)$  and  $(p, q-1)$  pairs are considered for determining the PCMAX tolerance
2. if uplink carrier leads in time over  $q$  and V2X UE sidelink transmission has SCI whose "Priority" field is set to a value larger than the high layer parameter  $\text{thresSL-TxPrioritization}$ , then  $q$  is the reference subframe and the  $(p, q)$  and  $(p+1, q)$  pairs are considered for determining the PCMAX tolerance
3. if V2X carrier leads in time over  $p$  and V2X UE sidelink transmission has SCI whose "Priority" field is set to a value less than the high layer parameter  $\text{thresSL-TxPrioritization}$ , then  $p$  is the reference subframe and the  $(p, q)$  and  $(p, q+1)$  pairs are considered for determining the PCMAX tolerance
4. if V2X carrier leads in time over  $p$  and V2X UE sidelink transmission has SCI whose "Priority" field is set to a value larger than the high layer parameter  $\text{thresSL-TxPrioritization}$ , then  $q$  is the reference subframe and the  $(p-1, q)$  and  $(p, q)$  pairs are considered for determining the PCMAX tolerance

For the reference subframe  $p$  duration when uplink carrier leads:

$$P'_{\text{CMAX}_L} = P_{\text{CMAX}_{L,c,E\text{-UTRA}}}(p)$$

$$P'_{\text{CMAX}_H} = \text{MAX}\{P_{\text{CMAX}_H}(p, q-1), P_{\text{CMAX}_H}(p, q)\}$$

For the reference subframe  $p$  duration when V2X carrier leads:

$$P'_{\text{CMAX}_L} = P_{\text{CMAX}_{L,c,E\text{-UTRA}}}(p)$$

$$P'_{\text{CMAX}_H} = \text{MAX}\{P_{\text{CMAX}_H}(p, q), P_{\text{CMAX}_H}(p, q+1)\}$$

For the reference subframe  $q$  duration when uplink carrier leads:

$$P'_{\text{CMAX}_L} = P_{\text{CMAX}_{L,c,E\text{-UTRA}}}(q)$$

$$P'_{\text{CMAX}_H} = \text{MAX}\{P_{\text{CMAX}_H}(p, q), P_{\text{CMAX}_H}(p+1, q)\}$$

For the reference subframe  $q$  duration when V2X carrier leads:

$$P'_{\text{CMAX}_L} = P_{\text{CMAX}_{L,c,E\text{-UTRA}}}(q)$$

$$P'_{\text{CMAX}_H} = \text{MAX}\{P_{\text{CMAX}_H}(p-1, q), P_{\text{CMAX}_H}(p, q)\}$$

where  $P_{\text{CMAX}_{L,c,E\text{-UTRA}}}(p)$  and  $P_{\text{CMAX}_H}$  are the applicable limits for each overlapping subframe pairs above 4 case with  $(p, q)$ ,  $(p, q-1)$  or  $(p, q)$ ,  $(p, q+1)$  or  $(p, q)$ ,  $(p+1, q)$  or  $(p, q)$ ,  $(p-1, q)$ . The measured total configured maximum output power  $P_{\text{UMAX}}$  shall be within the following bounds:

$$P'_{\text{CMAX}_L} - T_{\text{LOW}}(P'_{\text{CMAX}_L}) \leq P_{\text{UMAX}} \leq P'_{\text{CMAX}_H} + T_{\text{HIGH}}(P'_{\text{CMAX}_H})$$

with the tolerances  $T_{\text{LOW}}(P_{\text{CMAX}})$  and  $T_{\text{HIGH}}(P_{\text{CMAX}})$  for applicable values of  $P_{\text{CMAX}}$  specified in Table 6.2.5G-2.

For intra-band contiguous multi-carrier operation,  $\text{MPR}_c = \text{MPR}$  and  $\text{A-MPR}_c = \text{A-MPR}$  with  $\text{MPR}$  and  $\text{A-MPR}$  specified in subclause 6.2.3G and subclause 6.2.4G respectively. There is one power management term for the UE, denoted  $\text{P-MPR}$ , and  $\text{P-MPR}_c = \text{P-MPR}$ .  $P_{\text{CMAX}_c}$  is calculated under the assumption that the transmit power is increased by the same amount in dB on all component carriers.

The total configured maximum output power  $P_{\text{CMAX}}$  shall be set within the following bounds:

$$P_{\text{CMAX}_L} \leq P_{\text{CMAX}} \leq P_{\text{CMAX}_H}$$

$$P_{\text{CMAX}_L} = \text{MIN}\{10 \log_{10} \sum P_{\text{EMAX}_c} - \Delta T_C, P_{\text{PowerClass}} - \text{MAX}(\text{MPR} + \text{A-MPR} + \Delta T_{\text{IB},c} + \Delta T_C + \Delta T_{\text{ProSe}}, P\text{-MPR}), P_{\text{Regulatory}}\}$$

$$P_{\text{CMAX}_H} = \text{MIN}\{10 \log_{10} \sum P_{\text{EMAX}_c}, P_{\text{PowerClass}}, P_{\text{Regulatory}}\}$$

where

- $P_{\text{EMAX}_c}$  is the linear value of  $P_{\text{EMAX}_c}$  which is given by IE *maxTxPower* in [7];
- $P_{\text{PowerClass}}$  is the maximum UE power specified in Table 6.2.2G-1 without taking into account the tolerance specified in the Table 6.2.2G-1;
- MPR and A-MPR are specified in subclause 6.2.3G and subclause 6.2.4G respectively;
- $\Delta T_{\text{IB},c}$  is the additional tolerance for serving cell  $c$  as specified in Table 6.2.5-2;
- P-MPR is the power management term for the UE;
- $\Delta T_C$  is the highest value  $\Delta T_{C,c}$  among all serving cells  $c$  in the subframe over both timeslots.  $\Delta T_{C,c} = 1.5$  dB when NOTE 2 in Table 6.2.2-1 applies, otherwise  $\Delta T_{C,c} = 0$  dB;
- $\Delta T_{\text{ProSe}}$  applies as specified in subclause 6.2.5.
- $P_{\text{Regulatory}} = 10 - G_{\text{post connector}}$  dBm when V2X UE is within the protected zone [13] of CEN DSRC tolling system and operating in Band 47;  $P_{\text{Regulatory}} = 33 - G_{\text{post connector}}$  dBm otherwise.

NOTE: The supported post antenna connector gain  $G_{\text{post connector}}$  declared by the UE following the principle described in annex I.

**Table 6.2.5G-1:  $\Delta T_{\text{IB},c}$  for inter-band con-current V2X operation (two bands)**

V2X con-current band Combination	E-UTRA or V2X Operating Band	$\Delta T_{\text{IB},c}$ [dB]
V2X_3-47	3	0.0
V2X_5-47	5	0.2
V2X_7-47	7	0.0
V2X_8-47	8	0.0
V2X_20-47	20	0.2
V2X_28A-47A	28	0.2
V2X_34-47	34	0.0
V2X_39-47	39	0.0
V2X_41-47	41	0.0
V2X_71A-47A	71	0.0

For V2X UE supporting Transmit Diversity, the transmitted power is configured per each UE.

If the UE transmits on two antenna connectors at the same time, the tolerance is specified in Table 6.2.5G-2 and 6.2.5G-3 for PC2 and PC3 V2X UE respectively.

**Table 6.2.5G-2:  $P_{\text{CMAX},c}$  tolerance in Transmit Diversity scheme for PC2 V2X UE**

$P_{\text{CMAX},c}$ (dBm)	Tolerance $T_{\text{LOW}}(P_{\text{CMAX},L,c})$ (dB)	Tolerance $T_{\text{HIGH}}(P_{\text{CMAX},H,c})$ (dB)
$P_{\text{CMAX},c} = 26$	3.0	2.0
$23 \leq P_{\text{CMAX},c} < 26$	4.0	2.0
$22 \leq P_{\text{CMAX},c} < 23$	5.0	2.0
$21 \leq P_{\text{CMAX},c} < 22$	5.0	3.0
$20 \leq P_{\text{CMAX},c} < 21$	6.0	4.0
$16 \leq P_{\text{CMAX},c} < 20$	5.0	
$11 \leq P_{\text{CMAX},c} < 16$	6.0	
$-30 \leq P_{\text{CMAX},c} < 11$	7.0	

**Table 6.2.5G-3:  $P_{\text{CMAX},c}$  tolerance in Transmit Diversity scheme for PC3 V2X UE**

$P_{\text{CMAX},c}$ (dBm)	Tolerance $T_{\text{LOW}}(P_{\text{CMAX},L,c})$ (dB)	Tolerance $T_{\text{HIGH}}(P_{\text{CMAX},H,c})$ (dB)
$P_{\text{CMAX},c} = 23$	3.0	2.0
$22 \leq P_{\text{CMAX},c} < 23$	5.0	2.0
$21 \leq P_{\text{CMAX},c} < 22$	5.0	3.0
$20 \leq P_{\text{CMAX},c} < 21$	6.0	4.0
$16 \leq P_{\text{CMAX},c} < 20$	5.0	
$11 \leq P_{\text{CMAX},c} < 16$	6.0	
$-40 \leq P_{\text{CMAX},c} < 11$	7.0	

If the UE transmits on one antenna connector at a time, the requirements in Table 6.2.5-1 apply to the active antenna connector.

## 6.3 Output power dynamics

### 6.3.1 (Void)

### 6.3.2 Minimum output power

The minimum controlled output power of the UE is defined as the broadband transmit power of the UE, i.e. the power in the channel bandwidth for all transmit bandwidth configurations (resource blocks), when the power is set to a minimum value.

#### 6.3.2.1 Minimum requirement

The minimum output power is defined as the mean power in one sub-frame (1ms). The minimum output power shall not exceed the values specified in Table 6.3.2.1-1.

**Table 6.3.2.1-1: Minimum output power**

	Channel bandwidth / Minimum output power / Measurement bandwidth					
	1.4 MHz	3.0 MHz	5 MHz	10 MHz	15 MHz	20 MHz
Minimum output power	-40 dBm					
Measurement bandwidth	1.08 MHz	2.7 MHz	4.5 MHz	9.0 MHz	13.5 MHz	18 MHz

#### 6.3.2A UE Minimum output power for CA

For inter-band carrier aggregation with uplink assigned to two E-UTRA bands and intra-band contiguous and non-contiguous carrier aggregation, the minimum controlled output power of the UE is defined as the transmit power of the



UE per component carrier, i.e., the power in the channel bandwidth of each component carrier for all transmit bandwidth configurations (resource blocks), when the power on both component carriers are set to a minimum value.

### 6.3.2A.1 Minimum requirement for CA

For inter-band carrier aggregation with uplink assigned to two E-UTRA bands, the minimum output power is defined and the requirement is specified in subclause 6.3.2.1. If two contiguous component carriers are assigned to one E-UTRA band, the requirements in subclause 6.3.2A.1 apply for those component carriers.

For intra-band contiguous and non-contiguous carrier aggregation the minimum output power is defined as the mean power in one sub-frame (1ms). The minimum output power shall not exceed the values specified in Table 6.3.2A.1-1.

**Table 6.3.2A.1-1: Minimum output power for intra-band contiguous and non-contiguous CA UE**

	CC Channel bandwidth / Minimum output power / Measurement bandwidth					
	1.4 MHz	3.0 MHz	5 MHz	10 MHz	15 MHz	20 MHz
Minimum output power	-40 dBm					
Measurement bandwidth			4.5 MHz	9.0 MHz	13.5 MHz	18 MHz

### 6.3.2B UE Minimum output power for UL-MIMO

For UE supporting UL-MIMO, the minimum controlled output power is defined as the broadband transmit power of the UE, i.e. the sum of the power in the channel bandwidth for all transmit bandwidth configurations (resource blocks) at each transmit antenna connector, when the UE power is set to a minimum value.

#### 6.3.2B.1 Minimum requirement

For UE with two transmit antenna connectors in closed-loop spatial multiplexing scheme, the minimum output power is defined as the sum of the mean power at each transmit connector in one sub-frame (1ms). The minimum output power shall not exceed the values specified in Table 6.3.2B.1-1.

**Table 6.3.2B.1-1: Minimum output power**

	Channel bandwidth / Minimum output power / Measurement bandwidth					
	1.4 MHz	3.0 MHz	5 MHz	10 MHz	15 MHz	20 MHz
Minimum output power	-40 dBm					
Measurement bandwidth	1.08 MHz	2.7 MHz	4.5 MHz	9.0 MHz	13.5 MHz	18 MHz

If UE is configured for transmission on single-antenna port, the requirements in subclause 6.3.2 apply.

### 6.3.2C Void

<reserved for future use>

### 6.3.2D UE Minimum output power for ProSe

When UE is configured for E-UTRA ProSe sidelink transmissions non-concurrent with E-UTRA uplink transmissions for E-UTRA ProSe operating bands specified in Table 5.5D-1, the requirements in subclause 6.3.2 apply for ProSe transmission.

When UE is configured for simultaneous E-UTRA ProSe sidelink and E-UTRA uplink transmissions for inter-band E-UTRA ProSe / E-UTRA bands specified in Table 5.5D-2, the requirements in subclause 6.3.2A apply as specified for the corresponding inter-band aggregation with uplink assigned to two bands.

### 6.3.2F UE Minimum output power for category NB1 and NB2

For category NB1 and NB2 UE the single-tone and multi-tone transmission minimum output power requirement for the channel bandwidth is -40 dBm. For 3.75kHz sub-carrier spacing the minimum output power is defined as mean power in one slot (2ms) excluding the 2304Ts gap when UE is not transmitting. For 15kHz sub-carrier spacing the minimum output power is defined as mean power in one sub-frame (1ms).

### 6.3.2G UE Minimum output power for V2X Communication

When UE is configured for E-UTRA V2X sidelink transmissions non-concurrent with E-UTRA uplink transmissions for E-UTRA V2X operating bands specified in Table 5.5G-1, the minimum output power shall not exceed the values specified in Table 6.3.2G-1.

**Table 6.3.2G-1: Minimum output power**

	Channel bandwidth / Minimum output power / Measurement bandwidth					
	1.4 MHz	3.0 MHz	5 MHz	10 MHz	15 MHz	20 MHz
Minimum output power	-30 dBm					
Measurement bandwidth				9.0 MHz		18 MHz

When UE is configured for simultaneous E-UTRA V2X sidelink and E-UTRA uplink transmissions for inter-band E-UTRA V2X / E-UTRA bands specified in Table 5.5G-2, the requirements specified in subclause 6.3.2 shall apply for the uplink and the requirements specified in subclause 6.3.2G shall apply for the sidelink.

For intra-band contiguous E-UTRA V2X multiple carrier transmissions, the requirements specified in subclause 6.3.2G shall apply for each sidelink carrier.

For V2X UE supporting Transmit Diversity, if the UE transmits on two antenna connectors at the same time, the minimum output power is defined as the sum of the mean power at each transmit connector in one sub-frame (1ms). The minimum output power shall not exceed the values specified for single carrier.

If the UE transmits on one antenna connector at a time, the requirements specified for single carrier shall apply to the active antenna connector.

## 6.3.3 Transmit OFF power

Transmit OFF power is defined as the mean power when the transmitter is OFF. The transmitter is considered to be OFF when the UE is not allowed to transmit or during periods when the UE is not transmitting a sub-frame. During DTX and measurements gaps, the UE is not considered to be OFF.

### 6.3.3.1. Minimum requirement

The transmit OFF power is defined as the mean power in a duration of at least one sub-frame (1ms) excluding any transient periods. The transmit OFF power shall not exceed the values specified in Table 6.3.3.1-1.

**Table 6.3.3.1-1: Transmit OFF power**

	Channel bandwidth / Transmit OFF power / Measurement bandwidth					
	1.4 MHz	3.0 MHz	5 MHz	10 MHz	15 MHz	20 MHz
Transmit OFF power	-50 dBm					
Measurement bandwidth	1.08 MHz	2.7 MHz	4.5 MHz	9.0 MHz	13.5 MHz	18 MHz

### 6.3.3A UE Transmit OFF power for CA

For inter-band carrier aggregation with uplink assigned to two E-UTRA bands and intra-band contiguous and non-contiguous carrier aggregation, transmit OFF power is defined as the mean power per component carrier when the transmitter is OFF on all component carriers. The transmitter is considered to be OFF when the UE is not allowed to transmit or during periods when the UE is not transmitting a sub-frame. During measurements gaps, the UE is not considered to be OFF.

#### 6.3.3A.1 Minimum requirement for CA

For inter-band carrier aggregation with uplink assigned to two E-UTRA bands, transmit OFF power requirement is defined per carrier and the requirement is specified in subclause 6.3.3.1. If two contiguous component carriers are assigned to one E-UTRA band, the requirements in subclause 6.3.3A.1 apply for those component carriers.

For intra-band contiguous and non-contiguous carrier aggregation the transmit OFF power is defined as the mean power in a duration of at least one sub-frame (1ms) excluding any transient periods. The transmit OFF power shall not exceed the values specified in Table 6.3.3A.1-1.

**Table 6.3.3A.1-1: Transmit OFF power for intra-band contiguous and non-contiguous CA UE**

	CC Channel bandwidth / Transmit OFF power / Measurement bandwidth					
	1.4 MHz	3.0 MHz	5 MHz	10 MHz	15 MHz	20 MHz
Transmit OFF power	-50 dBm					
Measurement bandwidth			4.5 MHz	9.0 MHz	13.5 MHz	18 MHz

### 6.3.3B UE Transmit OFF power for UL-MIMO

For UE supporting UL-MIMO, the transmit OFF power is defined as the mean power at each transmit antenna connector when the transmitter is OFF at all transmit antenna connectors. The transmitter is considered to be OFF when the UE is not allowed to transmit or during periods when the UE is not transmitting a sub-frame. During DTX and measurements gaps, the UE is not considered to be OFF.

#### 6.3.3B.1 Minimum requirement

The transmit OFF power is defined as the mean power at each transmit antenna connector in a duration of at least one sub-frame (1ms) excluding any transient periods. The transmit OFF power at each transmit antenna connector shall not exceed the values specified in Table 6.3.3B.1-1.

**Table 6.3.3B.1-1: Transmit OFF power per antenna port**

	Channel bandwidth / Transmit OFF power/ Measurement bandwidth					
	1.4 MHz	3.0 MHz	5 MHz	10 MHz	15 MHz	20 MHz
Transmit OFF power	-50 dBm					
Measurement bandwidth	1.08 MHz	2.7 MHz	4.5 MHz	9.0 MHz	13.5 MHz	18 MHz

### 6.3.3D Transmit OFF power for ProSe

When UE is configured for E-UTRA ProSe sidelink transmissions non-concurrent with E-UTRA uplink transmissions for E-UTRA ProSe operating bands specified in Table 5.5D-1, the ProSe UE shall meet the Transmit OFF power at all times when the UE is not associated with a serving cell on the ProSe carrier and does not have knowledge of its geographical area or is provisioned with pre-configured radio parameters that are not associated with any known Geographical Area.

The requirements specified in subclause 6.3.3 shall apply to UE supporting ProSe when

- the UE is associated with a serving cell on the ProSe carrier, or
- the UE is not associated with a serving cell on the ProSe carrier and is provisioned with the preconfigured radio parameters for ProSe Direct Communications and/or ProSe Direct Discovery that are associated with known Geographical Area, or
- the UE is associated with a serving cell on a carrier different than the ProSe carrier, and the radio parameters for ProSe Direct Discovery on the ProSe carrier are provided by the serving cell, or
- the UE is associated with a serving cell on a carrier different than the ProSe carrier, and has a non-serving cell selected on the ProSe carrier that supports ProSe Direct Discovery and/or ProSe Direct Communication.

When UE is configured for simultaneous E-UTRA ProSe sidelink and E-UTRA uplink transmissions for inter-band E-UTRA ProSe / E-UTRA bands specified in Table 5.5D-2, transmit OFF power is defined as the mean power per component carrier when the transmitter is OFF on all component carriers. During measurement gaps and transmission/reception gaps for ProSe, the UE is not considered to be OFF. Transmit OFF power requirement as specified in subclause 6.3.3 apply per carrier.

### 6.3.3F Transmit OFF power for category NB1 and NB2

For category NB1 and NB2 UE the transmit OFF power requirement for the channel bandwidth is -50 dBm. For 3.75kHz sub-carrier spacing the transmit OFF power is defined as mean power in one slot (2ms) excluding the 2304Ts gap when UE is not transmitting. For 15kHz sub-carrier spacing the transmit OFF power is defined as mean power in one sub-frame (1ms).

### 6.3.3G Transmit OFF power for V2X Communication

When UE is configured for E-UTRA V2X sidelink transmissions non-concurrent with E-UTRA uplink transmissions for E-UTRA V2X operating bands specified in Table 5.5G-1, the V2X UE shall meet the Transmit OFF power in subclause 6.3.3D.

When UE is configured for simultaneous E-UTRA V2X sidelink and E-UTRA uplink transmissions for inter-band E-UTRA V2X / E-UTRA bands specified in Table 5.5G-2, the requirements in subclause 6.3.3A apply for as specified for the corresponding inter-band con-current operation with uplink assigned to two bands.

For intra-band contiguous E-UTRA V2X multiple carrier transmissions, the requirements in subclause 6.3.3A apply as specified for the corresponding intra band contiguous carrier aggregation.

The transmit OFF power is defined as the mean power at each transmit antenna connector.

The transmit OFF power at each transmit antenna connector shall not exceed the values specified for single carrier.

### 6.3.4 ON/OFF time mask

#### 6.3.4.1 General ON/OFF time mask

The General ON/OFF time mask defines the observation period between Transmit OFF and ON power and between Transmit ON and OFF power. ON/OFF scenarios include; the beginning or end of DTX, measurement gap, contiguous, and non contiguous transmission

The OFF power measurement period is defined in a duration of at least one subframe, or one slot or one subslot for sTTI, excluding any transient periods. The ON power is defined as the mean power over one subframe, or one slot or one subslot for sTTI, excluding any transient period.

There are no additional requirements on UE transmit power beyond that which is required in subclause 6.2.2 and subclause 6.6.2.3

The transient period length shall be no longer than the specified value in Table 6.3.4.1-1.

**Table 6.3.4.1-1: Transient period length depending on transmission length**

TTI pattern	Channel BW (MHz)	TTI Duration	Transient period length (μs)
Subframe TTI		1ms	20
Slot TTI	1.4	1 slot	20
	> 1.4	1 slot	10
Subslot TTI	1.4	2os or 3 os	20
	> 1.4	2os or 3 os	10

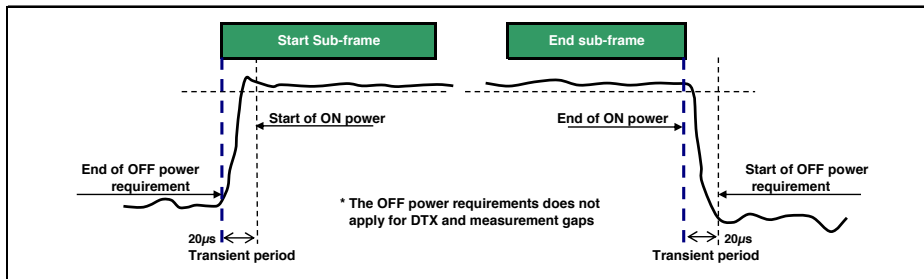

**Figure 6.3.4.1-1: General ON/OFF time mask for subframe TTI and for Frame Structure Type 1 and Frame Structure Type 2**

For Frame Structure Type 3 the general ON/OFF mask is specified in 6.3.4.1-1A with the PUSCH starting position modified by  $t_D = N_{start}^{FS3} T_s$  relative to the start of the sub-frame as indicated in the associated DCI, where  $N_{start}^{FS3}$  and the basic time unit  $T_s$  are specified in [4]. At the end of the sub-frame  $t_{end} = 0$  and  $t_{end} = T_{symp}$  with  $T_{symp}$  denoting the duration of the last SC-FDMA symbol when the bit indicating the PUSCH ending symbol in the associated DCI has value '0' and '1' as specified in [5], respectively; the OFF power requirement applies 5 μs after the end of the last symbol transmitted.

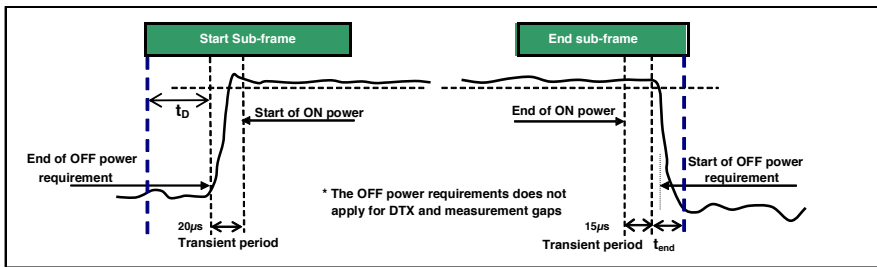

Figure 6.3.4.1-1A: General ON/OFF time mask for subframe TTI and for Frame Structure Type 3

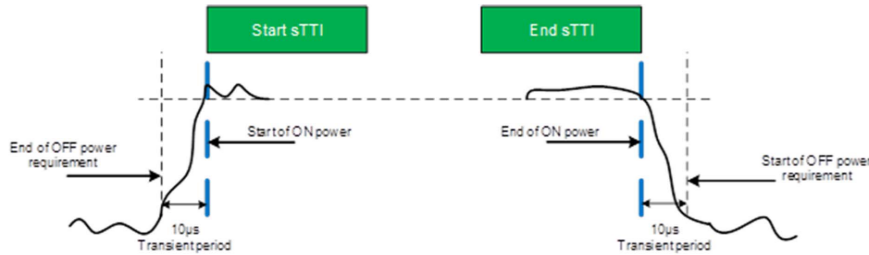

Figure 6.3.4.1-1B: General ON/OFF time mask for sTTI and for Frame Structure Type 1 and Frame Structure Type 2

6.3.4.2 PRACH and SRS time mask

6.3.4.2.1 PRACH time mask

The PRACH ON power is specified as the mean power over the PRACH measurement period excluding any transient periods as shown in Figure 6.3.4.2-1. The measurement period for different PRACH preamble format is specified in Table 6.3.4.2-1.

There are no additional requirements on UE transmit power beyond that which is required in subclause 6.2.2 and subclause 6.6.2.3

Table 6.3.4.2-1: PRACH ON power measurement period

PRACH preamble format	Measurement period (ms)
0	0.9031
1	1.4844
2	1.8031
3	2.2844
4	0.1479

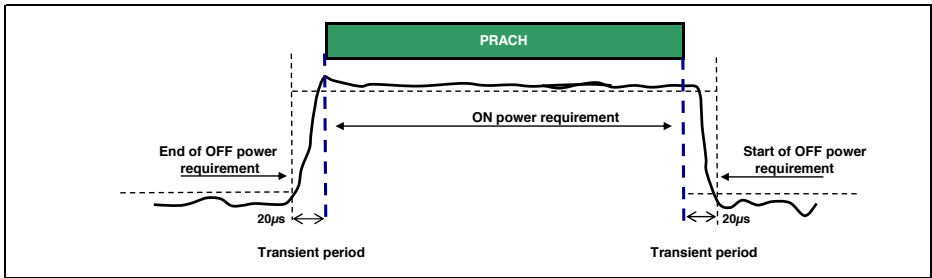

Figure 6.3.4.2-1: PRACH ON/OFF time mask

6.3.4.2.2 SRS time mask

In the case a single SRS transmission, the ON power is defined as the mean power over the symbol duration excluding any transient period; Figure 6.3.4.2.2-1 and Figure 6.3.4.2.2-1A.

In the case a dual SRS transmission, the ON power is defined as the mean power for each symbol duration excluding any transient period. Figure 6.3.4.2.2-2

There are no additional requirements on UE transmit power beyond that which is required in subclause 6.2.2 and subclause 6.6.2.3

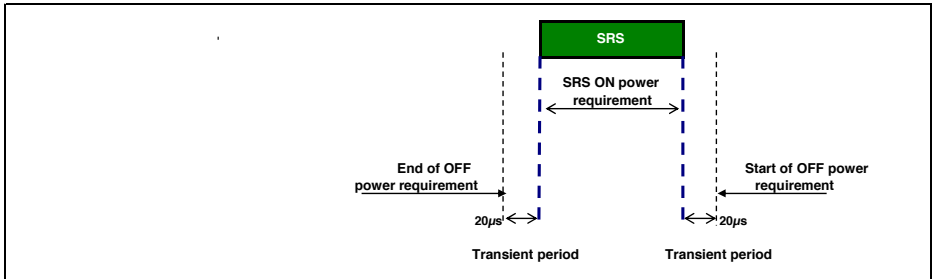

Figure 6.3.4.2.2-1: Single SRS time mask for Frame Structure Type 1 and Frame Structure Type 2

For Frame Structure Type 3 and single SRS transmission, the SRS time mask is specified in 6.3.4.2-2A; the OFF power requirement applies [5] µs after the end of the SRS symbol.

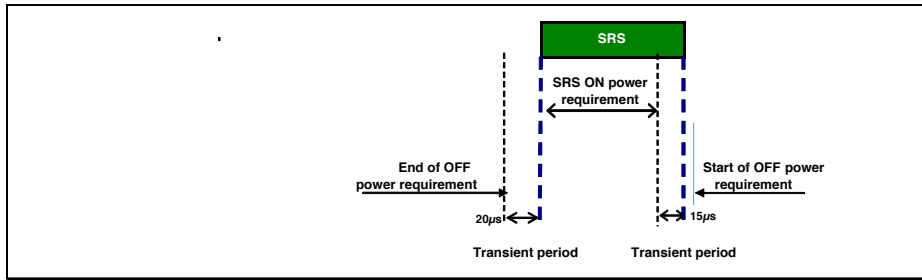

Figure 6.3.4.2.2-1A: Single SRS time mask for Frame Structure Type 3

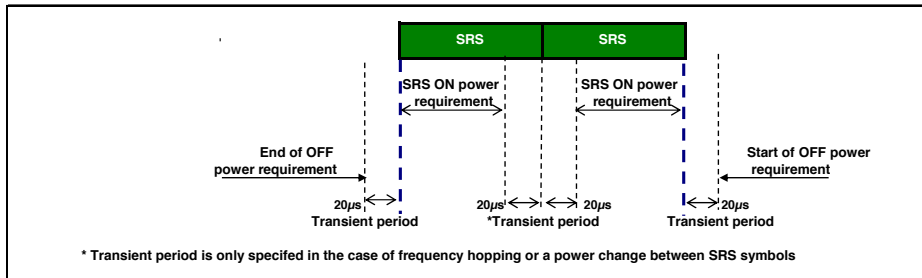

Figure 6.3.4.2.2-2: Dual SRS time mask for the case of UpPTS transmissions

For SRS transmission mapped to two or more OFDM symbols the ON power is defined as the mean power for each symbol duration excluding any transient period. For consecutive SRS transmissions without power change, Figure 6.3.4.2.2-3 applies.

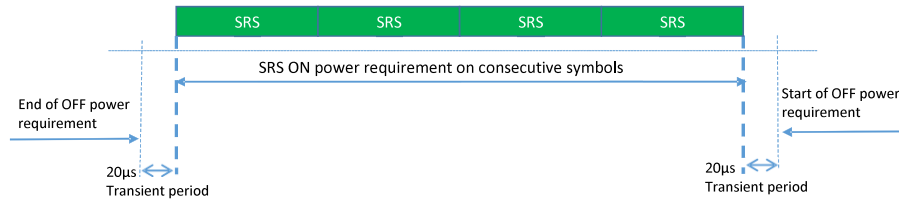

Figure 6.3.4.2.2-3: Consecutive SRS time mask for the case when no power change is required

When power change between consecutive SRS transmissions is required, then Figure 6.3.4.2.2-4 and Figure 6.3.4.2.2-5 apply.

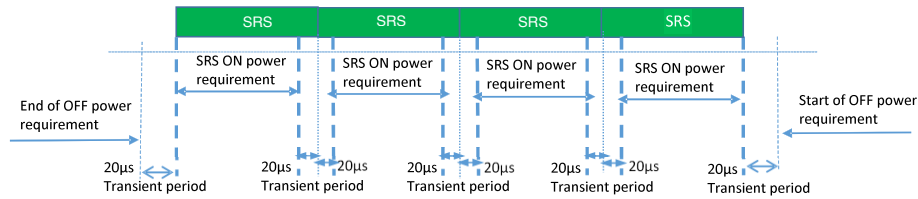

Figure 6.3.4.2.2-4: Consecutive SRS time mask for the case when power change is required



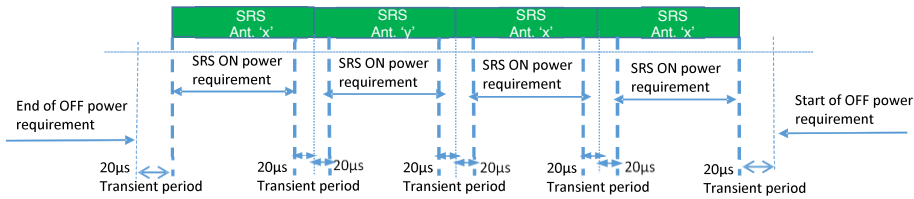

Figure 6.3.4.2.2-5: Time mask for SRS antenna switching

The above transient period applies to all the transmit CCs in CA with the CC sounding SRS. UE RF requirements do not apply during this transient period.

6.3.4.3 Slot / Sub frame boundary time mask for subframe TTI

The sub frame boundary time mask defines the observation period between the previous/subsequent sub-frame and the (reference) sub-frame. A transient period at a slot boundary within a sub-frame is only allowed in the case of Intra-sub frame frequency hopping. For the cases when the subframe contains SRS the time masks in subclause 6.3.4.4 apply.

There are no additional requirements on UE transmit power beyond that which is required in subclause 6.2.2 and subclause 6.6.2.3

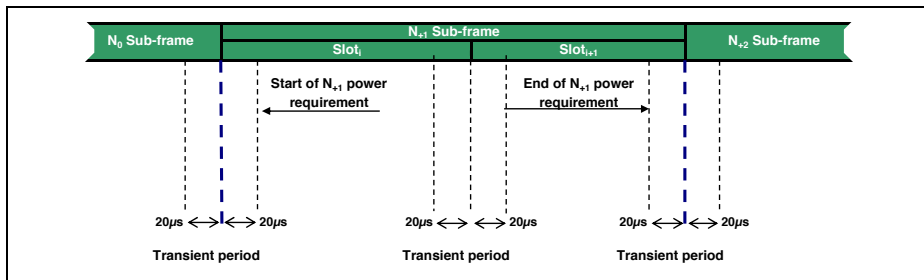
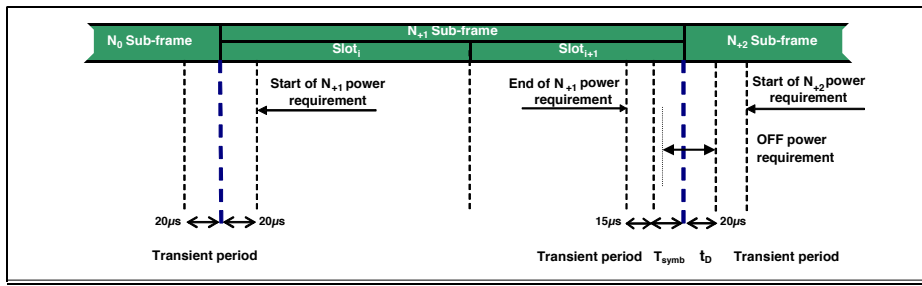

Figure 6.3.4.3-1: Transmission power template for Frame Structure Type 1 and Frame Structure Type 2

For Frame Structure Type 3 the sub-frame boundary time mask is specified in Figure 6.3.4.3-1A when the bit indicating the PUSCH ending symbol in the associated DCI has value '1' and the PUSCH starting position is modified by  $t_D$  in the following subframe (clause 6.3.4.1);  $T_{symbol}$  denotes the duration of the ending SC-FDMA symbol. the OFF power requirement applies 5 µs after the end of the last symbol transmitted.



**Figure 6.3.4.3-1A: Transmission power template when the bit in the associated DCI indicating the PUSCH ending symbol has value '1' for Frame Structure Type 3**

For Frame Structure Type 3 the first slot boundary time mask is specified in Figure 6.3.4.3-1B when the PUSCH mode is 3 indicated in DCI [4]. The PUSCH starting position modified by  $t_D = N_{start}^{FS3} T_s$  relative to the start of the sub-frame as indicated in the associated DCI, where  $N_{start}^{FS3}$  and the basic time unit  $T_s$  are specified in TS 36.211 [4]. At the end of the first slot  $t_{end} = 3 \cdot T_{symb}$  or  $t_{end} = 0$  with  $T_{symb}$  denoting the duration of one SC-FDMA symbol when the bit indicating the PUSCH ending symbol in the associated DCI is either fourth or seventh symbol as specified in TS 36.212 [5], respectively; the OFF power requirement applies 5 µs after the end of the last symbol transmitted.

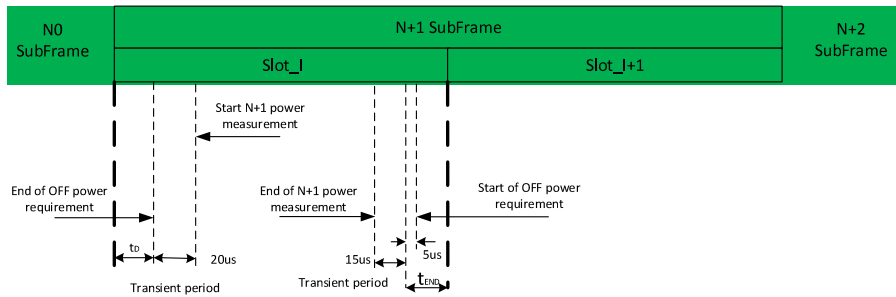

**Figure 6.3.4.3-1B: Transmission power template for the first slot in one subframe for Frame Structure Type 3**

For Frame Structure Type 3 the second slot boundary time mask is specified in Figure 6.3.4.3-1C when the PUSCH mode is 2 indicated in DCI [4]. The PUSCH starting position modified by  $t_D = N_{start}^{FS3} T_s$  relative to the start of the second slot as indicated in the associated DCI, where  $N_{start}^{FS3}$  and the basic time unit  $T_s$  are specified in TS 36.211 [4]. At the end of the second slot  $t_{end} = T_{symb}$  or  $t_{end} = 0$  with  $T_{symb}$  denoting the duration of one SC-FDMA symbol when the bit indicating the PUSCH ending symbol in the associated DCI is either thirteenth or fourteenth symbol as specified in TS 36.212 [5], respectively; the OFF power requirement applies 5 µs after the end of the last symbol transmitted.

For Frame Structure Type 3 the second slot boundary time mask specified in Figure 6.3.4.3-1C can also be applied when the PUSCH mode is 1 indicated in DCI [4] and transmission starts at the eighth symbol. The PUSCH starting position  $t_D = 0$  relative to the start of the second slot. At the end of the second slot  $t_{end} = T_{symb}$  or  $t_{end} = 0$  with  $T_{symb}$  denoting the duration of one SC-FDMA symbol when the bit indicating the PUSCH ending symbol in the associated DCI is either thirteenth or fourteenth symbol as specified in TS 36.212 [5], respectively; the OFF power requirement applies 5 µs after the end of the last symbol transmitted.

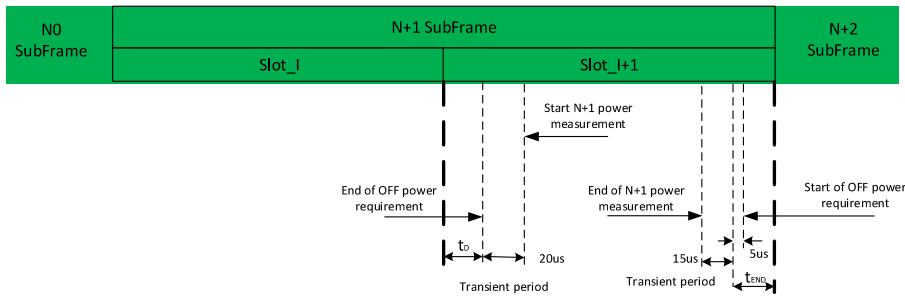

Figure 6.3.4.3-1C: Transmission power template for the second slot in one subframe for Frame Structure Type 3

6.3.4.4 PUCCH / PUSCH / SRS time mask for subframe TTI

The PUCCH/PUSCH/SRS time mask defines the observation period between sounding reference symbol (SRS) and an adjacent PUSCH/PUCCH symbol and subsequent sub-frame. The time masks apply for all types of frame structures and their allowed PUCCH/PUSCH/SRS transmissions unless otherwise stated.

There are no additional requirements on UE transmit power beyond that which is required in subclause 6.2.2 and subclause 6.6.2.3

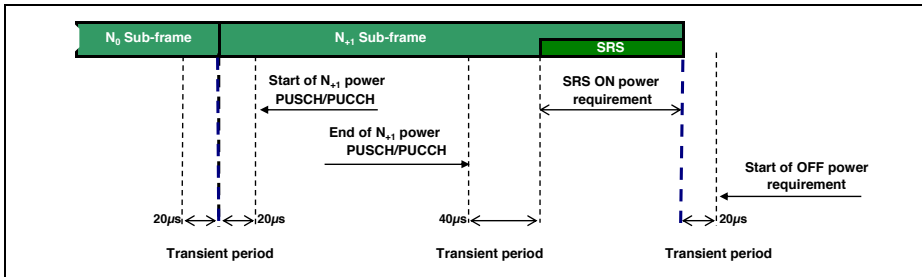

Figure 6.3.4.4-1: PUCCH/PUSCH/SRS time mask when there is a transmission before SRS but not after for Frame Structure Type 1 and Frame Structure Type 2

For Frame Structure Type 3 the PUSCH/SRS time mask when there is a transmission before SRS but not after is specified in Figure 6.3.4.4-1A; the OFF power requirement applies 5 µs after the end of the last symbol transmitted.

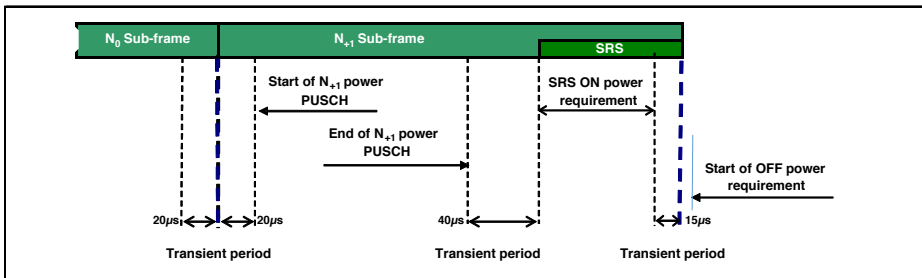

Figure 6.3.4.4-1A: PUSCH/SRS time mask when there is a transmission before SRS but not after for Frame Structure Type 3

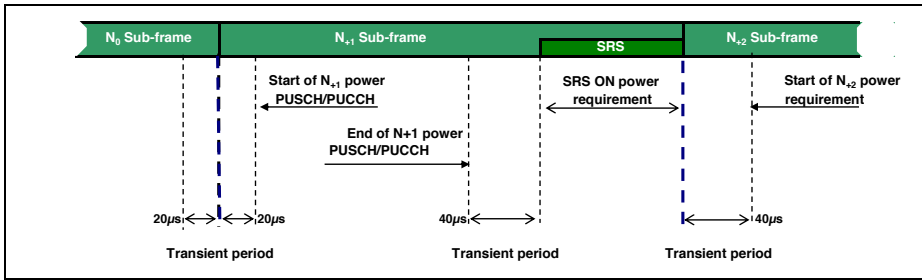

Figure 6.3.4.4-2: PUCCH/PUSCH/SRS time mask when there is transmission before and after SRS

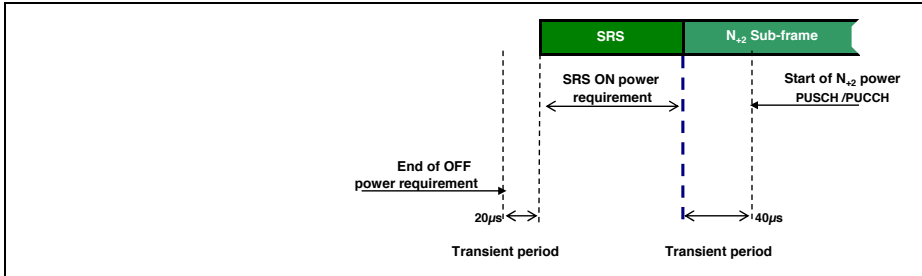

Figure 6.3.4.4-3: PUCCH/PUSCH/SRS time mask when there is a transmission after SRS but not before

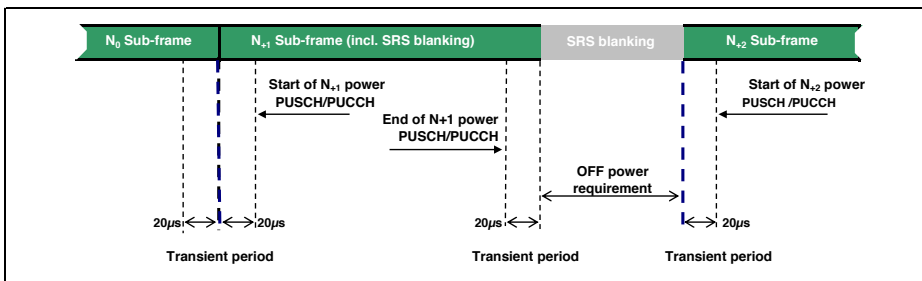

Figure 6.3.4.4-4: SRS time mask when there is FDD SRS blanking for Frame Structure Type 1 and Frame Structure Type 2

For Frame Structure Type 3 the PUSCH/SRS time mask with transmission after the SRS symbol and the PUSCH starting position modified by  $t_D$  in the following subframe (clause 6.3.4.1) is specified in Figure 6.3.4.4-4A when there is SRS blanking.

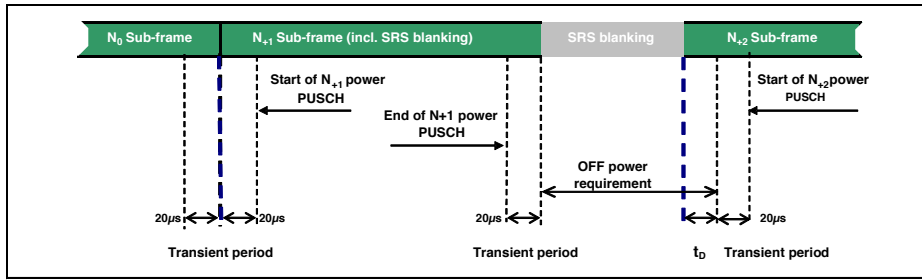

Figure 6.3.4.4-4A: SRS time mask when there is SRS blanking for Frame Structure Type 3

6.3.4.5 Symbol / Subslot boundary time mask for subslot TT1

The subslot boundary time mask defines the observation period between the previous/subsequent subslot and the (reference) subslot. A transient period at a symbol boundary within a subslot is only allowed in the case of Intra-subslot frequency hopping. For the cases when the subslot contains SRS the time masks in subclause 6.3.4.6 apply.

There are no additional requirements on UE transmit power beyond that which is required in subclause 6.2.2 and subclause 6.6.2.3

Following time masks requirements shall be applied:

- the transient period shall be equally shared between two consecutive Reference symbols or Data symbols (figure 6.3.4.5-1 and figure 6.3.4.5-4).
- Otherwise, the transient period shall be placed in the Reference symbol (figure 6.3.4.5-2 and figure 6.3.4.5-3).

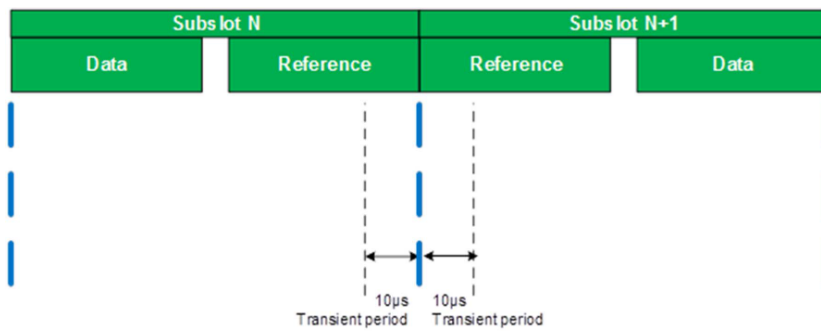

Figure 6.3.4.5-1: Transmission power template for subslot TT1 – transient period shared

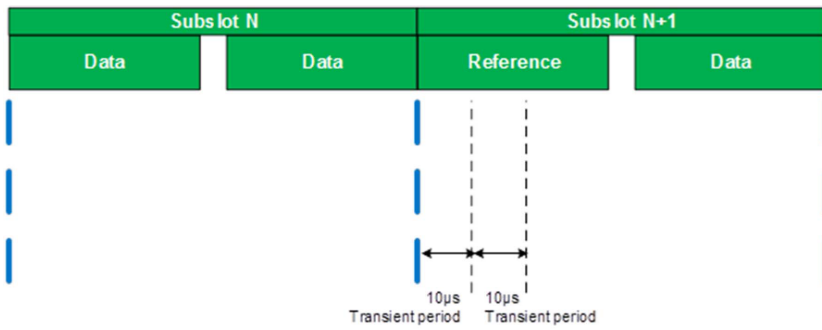

Figure 6.3.4.5-2: Transmission power template for subslot TTI – transient period not shared

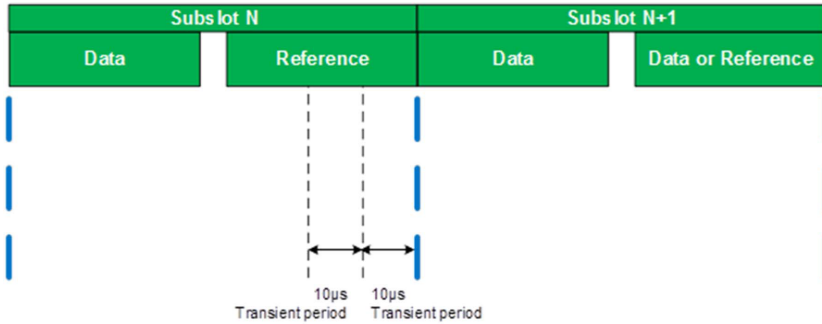

Figure 6.3.4.5-3: Transmission power template for subslot TTI – transient period not shared

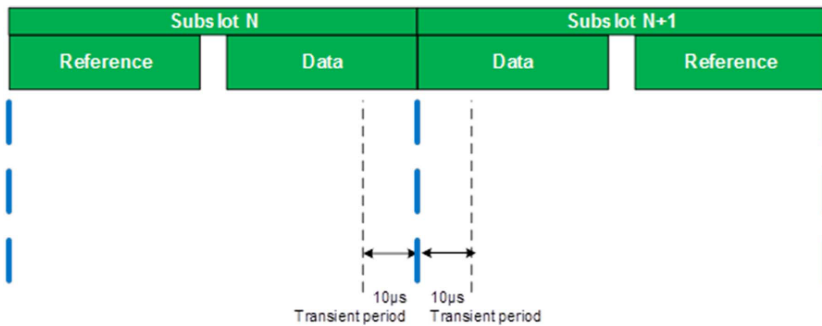

Figure 6.3.4.5-4: Transmission power template for subslot TTI – transient period shared

6.3.4.6 Subslot PUCCH / subslot PUSCH / SRS time mask for subslot TTI

The subslot PUCCH/subslot PUSCH/SRS time mask defines the observation period between sounding reference symbol (SRS) in the last symbol in subslot N and an adjacent subslot PUSCH/subslot PUCCH symbol in subslot N+1.

There are no additional requirements on UE transmit power beyond that which is required in subclause 6.2.2 and subclause 6.6.2.3

Following time masks requirement shall be applied when SRS is either transmitted or blanked:

- the transient period shall be placed in Reference symbol when the transient is in between Reference symbol and SRS (figure 6.3.4.6-1, figure 6.3.4.6-2, figure 6.3.4.6-5 and figure 6.3.4.6-7).
- the transient period shall be equally shared when the transient is in between Data symbol and SRS (figure 6.3.4.6-3 and figure 6.3.4.6-4).

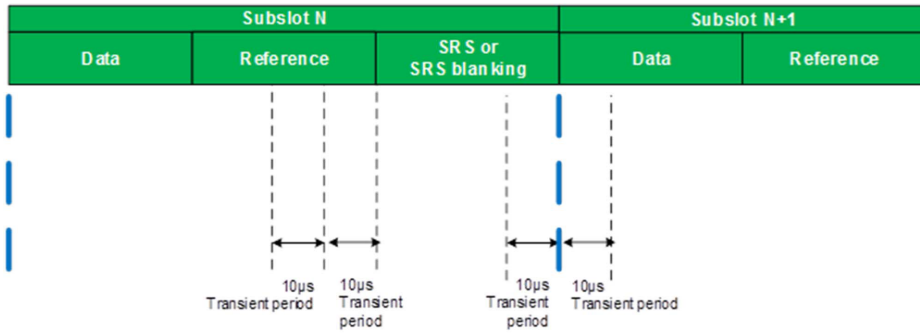

Figure 6.3.4.6-1: subslot PUSCH/SRS time mask when there is a Reference symbol before SRS (or SRS blanking) and data symbol after

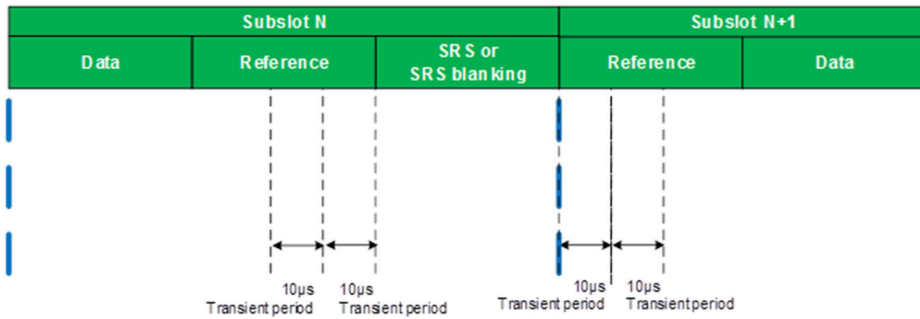

Figure 6.3.4.6-2: subslot PUSCH/SRS time mask when there is a Reference symbol before SRS (or SRS blanking) and Reference symbol after

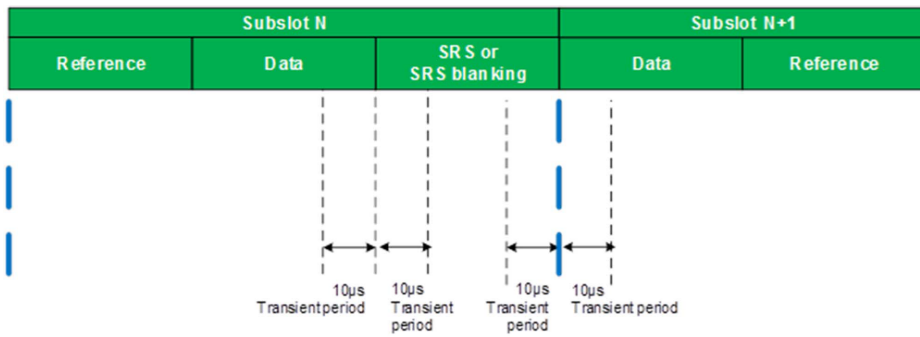

Figure 6.3.4.6-3: subslot PUSCH/SRS time mask when there is a data symbol before SRS (or SRS blanking) and data symbol after

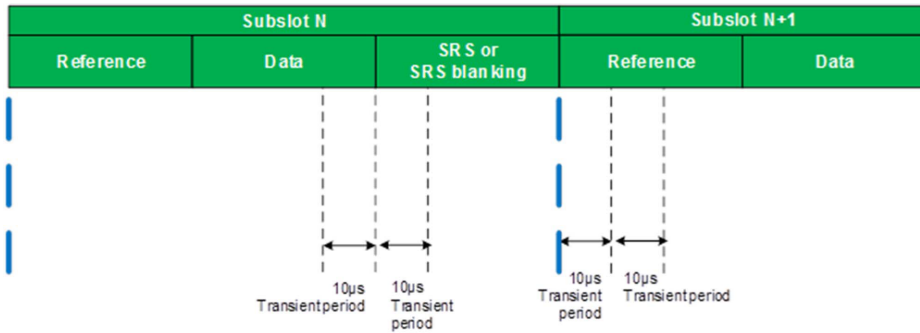

Figure 6.3.4.6-4: subslot PUSCH/SRS time mask when there is a data symbol before SRS (or SRS blanking) and Reference symbol after



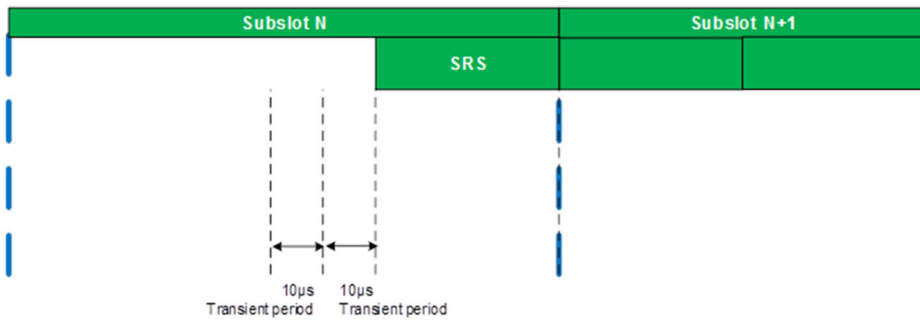

Figure 6.3.4.6-5: subslot PUSCH/SRS time mask when there is a no symbol before SRS

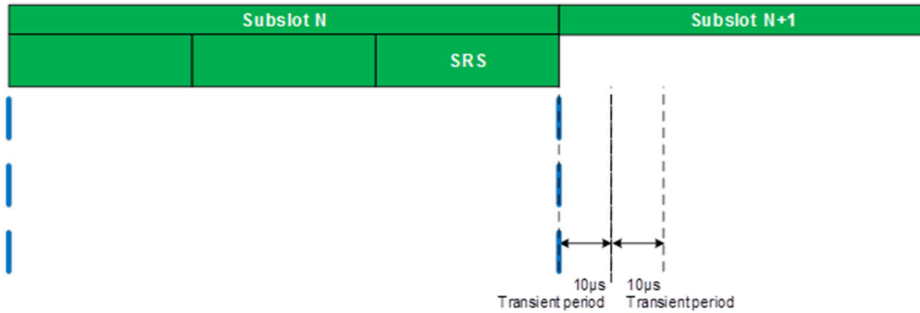

Figure 6.3.4.6-6: subslot PUSCH/SRS time mask when there is a no symbol after SRS

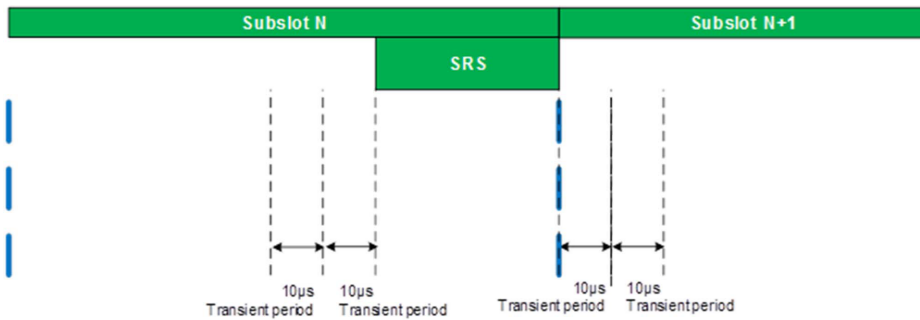

Figure 6.3.4.6-7: subslot PUSCH/SRS time mask when there is a no symbol before and after SRS

### 6.3.4.7 Symbol / Slot boundary time mask for slot TTI

The slot boundary time mask defines the observation period between the previous/subsequent slot and the (reference) slot. A transient period at a symbol boundary within a slot is only allowed in the case of Intra slot frequency hopping. For the cases when the slot contains SRS the time masks in subclause 6.3.4.8 shall apply.

There are no additional requirements on UE transmit power beyond that which is required in subclause 6.2.2 and subclause 6.6.2.3.

For slot boundary, the time masks specified in subclause 6.3.4.4 shall apply with a transient time of  $10\mu\text{s}$  instead of  $20\mu\text{s}$ .

For frequency hopping within the slot, the time masks specified in subclause 6.3.4.5 shall apply.

#### 6.3.4.8 Slot PUCCH / slot PUSCH / SRS time mask for slot TTI

The slot PUCCH/slot PUSCH/SRS time mask defines the observation period between sounding reference symbol (SRS) and an adjacent slot PUSCH/slot PUCCH symbol and subsequent slot.

There are no additional requirements on UE transmit power beyond that which is required in subclause 6.2.2 and subclause 6.6.2.3.

The time masks specified in subclause 6.3.4.4 shall apply.

#### 6.3.4.9 Consecutive subslot and slot TTI or consecutive subslot and subframe TTI time mask

The consecutive subslot and slot boundary time mask or consecutive subslot and subframe boundary time mask defines the observation period between the subslot and the slot or subframe.

There are no additional requirements on UE transmit power beyond that which is required in subclause 6.2.2 and subclause 6.6.2.3.

In this case, the transient period shall be placed in the subframe TTI or the slot TTI (figure 6.3.4.9-1)

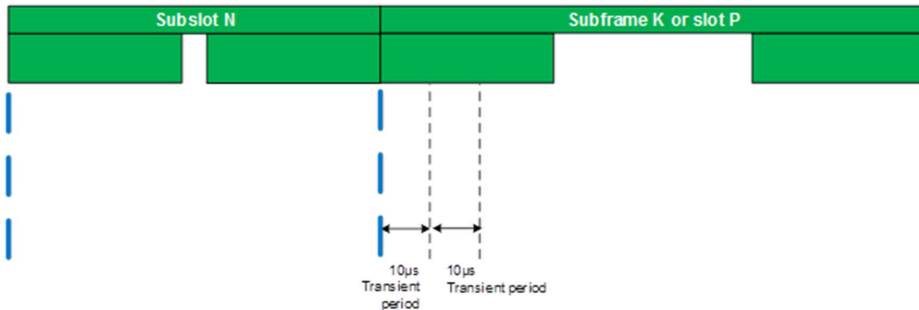

Figure 6.3.4.9-1: subslot TTI and subframe TTI boundary

#### 6.3.4.10 Consecutive subframe and subslot TTI or consecutive slot and subslot TTI time mask

The consecutive subframe and subslot boundary time mask or consecutive slot and subslot boundary time mask defines the observation period between the slot or subframe and the subslot.

There are no additional requirements on UE transmit power beyond that which is required in subclause 6.2.2 and subclause 6.6.2.3.

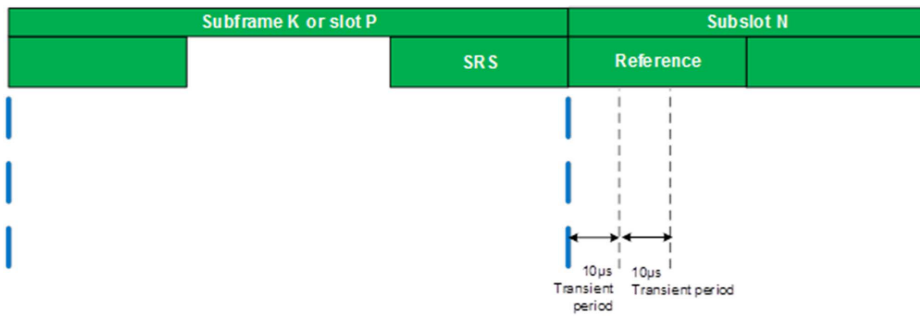

Figure 6.3.4.10-1: Subframe TTI and subslot TTI boundary with SRS in last subframe TTI symbol and Reference Symbol in first subslot TTI symbol

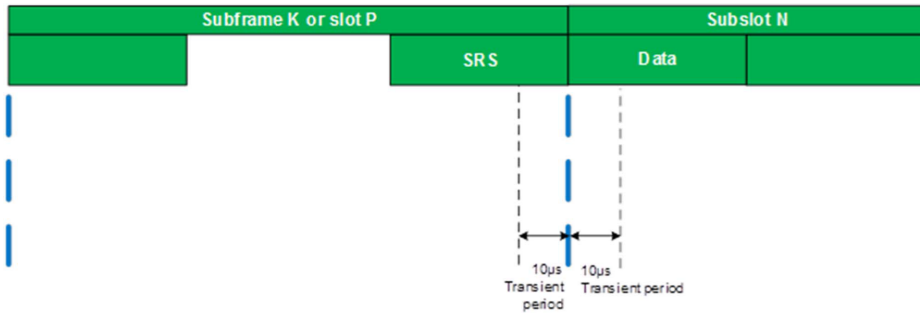

Figure 6.3.4.10-2: Subframe TTI and subslot TTI boundary with SRS in last subframe TTI symbol and data Symbol in first subslot TTI symbol

When the last symbol of the Subframe or slot is not SRS then the transient period is placed in the Subframe or Slot.

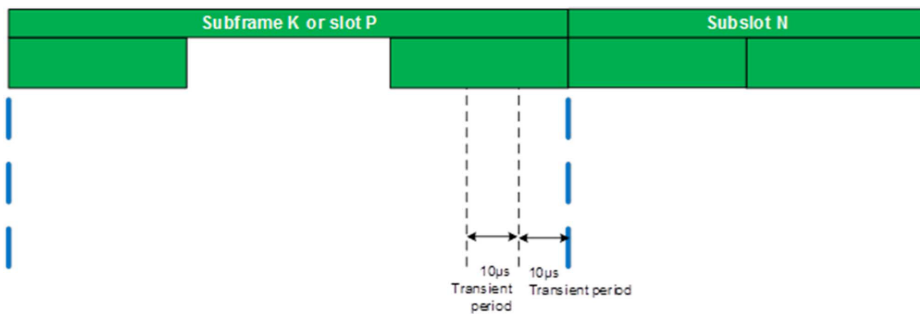

Figure 6.3.4.10-3: subframe TTI and subslot TTI boundary

6.3.4.11 Consecutive TTI and slot TTI or consecutive slot TTI and TTI time mask

The consecutive subframe and slot boundary time mask or consecutive slot and subframe boundary time mask defines the observation period between the subframe and the slot or the slot and the subframe.

There are no additional requirements on UE transmit power beyond that which is required in subclause 6.2.2 and subclause 6.6.2.3

The time masks at subframe boundary specified in subclause 6.3.4.3 or at slot boundary specified in subclause 6.3.4.7 shall apply.

### 6.3.4A ON/OFF time mask for CA

For inter-band carrier aggregation with uplink assigned to two E-UTRA bands and intra-band contiguous and non-contiguous carrier aggregation, the general output power ON/OFF time mask specified in subclause 6.3.4.1 is applicable for each component carrier during the ON power period and the transient periods. The OFF period as specified in subclause 6.3.4.1 shall only be applicable for each component carrier when all the component carriers are OFF.

### 6.3.4B ON/OFF time mask for UL-MIMO

For UE supporting UL-MIMO, the ON/OFF time mask requirements in subclause 6.3.4 apply at each transmit antenna connector.

For UE with two transmit antenna connectors in closed-loop spatial multiplexing scheme, the general ON/OFF time mask requirements specified in subclause 6.3.4.1 apply to each transmit antenna connector. The requirements shall be met with the UL-MIMO configurations specified in Table 6.2.2B-2.

If UE is configured for transmission on single-antenna port, the requirements in subclause 6.3.4 apply.

### 6.3.4D ON/OFF time mask for ProSe

For ProSe Direct Discovery and ProSe Direct Communications, additional requirements on ON/OFF time masks for ProSe physical channels and signals are specified in this clause.

When UE is configured for simultaneous E-UTRA ProSe sidelink and E-UTRA uplink transmissions for inter-band E-UTRA ProSe / E-UTRA bands specified in Table 5.5D-2, the requirements in subclause 6.3.4D apply for ProSe transmission and the requirements in subclause 6.3.4 apply for uplink transmission.

#### 6.3.4D.1 General time mask for ProSe

The General ON/OFF time mask defines the observation period between the Transmit OFF and ON power and between Transmit ON and OFF power for PSDCH, PSCCH, and PSSCH transmissions in a subframe wherein the last symbol is punctured to create a guard period.

There are no additional requirements on UE transmit power beyond that which is required in subclause 6.2.2 and subclause 6.6.2.3.

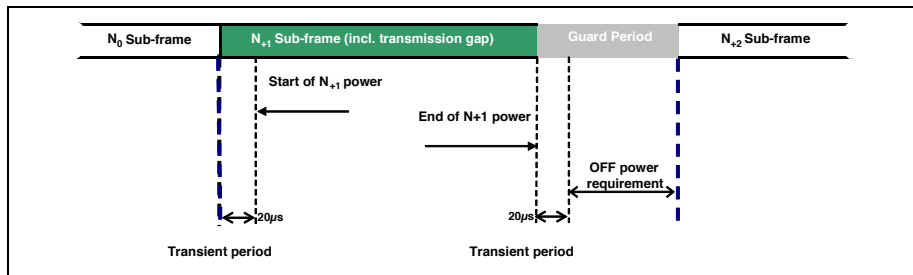

Figure 6.3.4D.1-1: PSDCH/PSCCH/PSSCH time mask

### 6.3.4D.2 PSSS/SSSS time mask

The PSSS time mask / SSSS time mask defines the observation period between the Transmit OFF and ON power and between Transmit ON and OFF power for PSSS/SSSS transmissions in a subframe when not multiplexed with PSBCH in that subframe.

There are no additional requirements on UE transmit power beyond that which is required in subclause 6.2.2 and subclause 6.6.2.3.

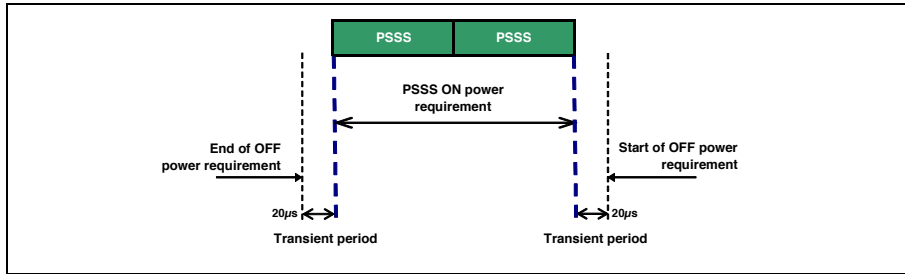

Figure 6.3.4D.2-1: PSSS time mask for normal CP transmission (when not time-multiplexed with PSBCH)

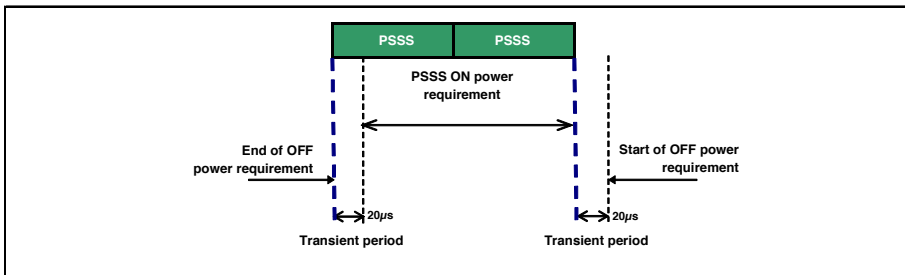

Figure 6.3.4D.2-2: PSSS time mask for extended CP transmission (when not time-multiplexed with PSBCH)

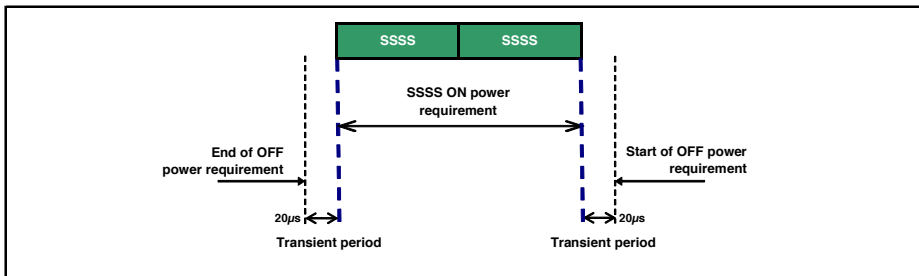

Figure 6.3.4D.2-3: SSSS time mask (when not time-multiplexed with PSBCH)

### 6.3.4D.3 PSSS / SSSS / PSBCH time mask

The PSSS/SSSS/PSBCH time mask defines the observation period between SSSS and adjacent PSSS/PSBCH symbols in a subframe, with last symbol punctured to create a guard period.

There are no additional requirements on UE transmit power beyond that which is required in subclause 6.2.2 and subclause 6.6.2.3.

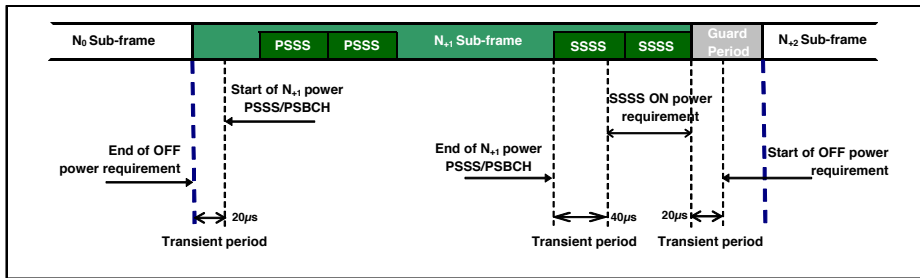

Figure 6.3.4D.3-1: PSSS/SSSS/PBCH time mask for normal CP transmission

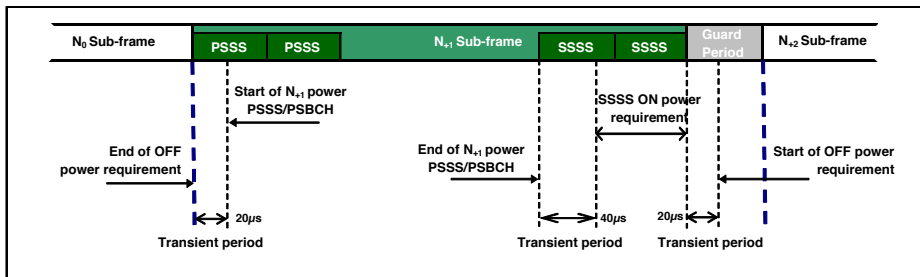

Figure 6.3.4D.3-2: PSSS/SSSS/PBCH time mask for extended CP transmission

### 6.3.4D.4 PSSCH / SRS time mask

The PSSCH/SRS time mask defines the observation period between sounding reference symbol (SRS) and an adjacent PSSCH symbol and subsequent sub-frame.

There are no additional requirements on UE transmit power beyond that which is required in subclause 6.2.2 and subclause 6.6.2.3.

The PSSCH/SRS time mask shall follow the PUSCH/PUCCH/SRS time mask as specified in subclause 6.3.4.4.

### 6.3.4F ON/OFF time mask for category NB1 and NB2

#### 6.3.4F.1 General ON/OFF time mask

E-UTRA general ON/OFF time mask in subclause 6.3.4.1 applies for category NB1 and NB2 UE with an exception that for 3.75kHz sub-carrier spacing the transmit OFF power is defined as mean power in one slot (2ms) and for 15kHz sub-

carrier spacing the transmit OFF power is defined as mean power in one sub-frame (1ms), excluding any transient periods. The ON power is defined as the mean power over one RU excluding any transient periods.

### 6.3.4F.2 NPRACH time mask

The NPRACH ON power is specified as the mean power over the NPRACH measurement period excluding any transient periods as shown in Figure 6.3.4F.2-1. The measurement period for different NPRACH preamble format is specified in Table 6.3.4F.2-1.

There are no additional requirements on UE transmit power beyond that which is required in subclause 6.2.2F and subclause 6.6.2.3F.

**Table 6.3.4F.2-1: NPRACH ON power measurement period**

NPRACH preamble format	Measurement period (ms)
0	5.6
1	6.4

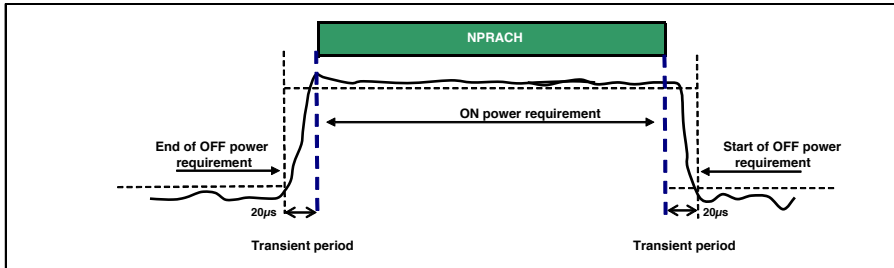

**Figure 6.3.4F.2-1: NPRACH ON/OFF time mask**

### 6.3.4G ON/OFF time mask for V2X Communication

For V2X Communications, additional requirements on ON/OFF time masks for V2X physical channels and signals are specified in this clause.

The General ON/OFF time mask in subclause 6.3.4D.1 and PSSS/SSSS time mask in subclause 6.3.4D.2 are applied for E-UTRA V2X sidelink UE.

When UE is configured for simultaneous E-UTRA V2X sidelink and E-UTRA uplink transmissions for inter-band E-UTRA V2X / E-UTRA bands specified in Table 5.5G-2, the requirements in subclause 6.3.4G apply for the V2X sidelink transmission and the requirements in subclause 6.3.4 apply for the E-UTRA uplink transmission.

For intra-band contiguous multi-carrier operation the general ON/OFF time mask is applicable for each component carrier during the ON power period and the transient periods. The OFF period shall only be applicable for each component carrier when all the component carriers are OFF.

For V2X UE supporting Transmit Diversity, the ON/OFF time mask requirements apply at each transmit antenna connector.

If the UE transmits on two antenna connectors at the same time, the general ON/OFF time mask requirements apply to each transmit antenna connector.

If the UE transmits on one antenna connector at a time, the general ON/OFF time mask requirements apply to the active antenna connector.

### 6.3.4G.1 PSSS / SSSS / PSBCH time mask

The PSSS/SSSS/PSBCH time mask for V2X UE defines the observation period between SSSS and adjacent PSSS/PSBCH symbols in a subframe, with last symbol punctured to create a guard period.

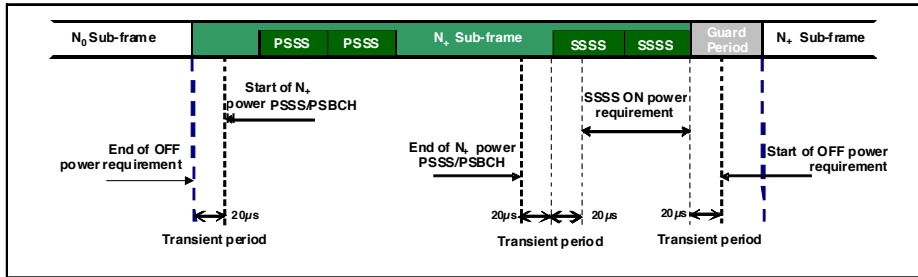

Figure 6.3.4G.1-1: PSSS/SSSS/PSBCH time mask for normal CP transmission for V2X Service

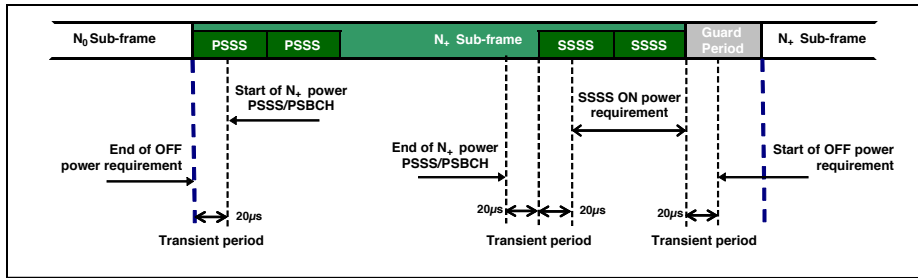

Figure 6.3.4G.1-2: PSSS/SSSS/PSBCH time mask for extended CP transmission for V2X Service

## 6.3.5 Power Control

### 6.3.5.1 Absolute power tolerance

Absolute power tolerance is the ability of the UE transmitter to set its initial output power to a specific value for the first sub-frame at the start of a contiguous transmission or non-contiguous transmission with a transmission gap larger than 20ms. This tolerance includes the channel estimation error (the absolute RSRP accuracy requirement specified in subclause 9.1 of TS 36.133). In the case of a PRACH transmission, the absolute tolerance is specified for the first preamble. The absolute power tolerance includes the channel estimation error (the absolute RSRP accuracy requirement specified in subclause 9.1 of TS 36.133).

#### 6.3.5.1.1 Minimum requirements

The minimum requirement for absolute power tolerance is given in Table 6.3.5.1.1-1 over the power range bounded by the Maximum output power as defined in subclause 6.2.2 and the Minimum output power as defined in subclause 6.3.2.

For operating bands under NOTE 2 in Table 6.2.2-1, the absolute power tolerance as specified in Table 6.3.5.1.1-1 is relaxed by reducing the lower limit by 1.5 dB when the transmission bandwidth is confined within  $F_{UL\_low}$  and  $F_{UL\_low} + 4$  MHz or  $F_{UL\_high} - 4$  MHz and  $F_{UL\_high}$ .



**Table 6.3.5.1.1-1: Absolute power tolerance**

Conditions	Tolerance
Normal	$\pm 9.0$ dB
Extreme	$\pm 12.0$ dB

### 6.3.5.2 Relative Power tolerance

The relative power tolerance is the ability of the UE transmitter to set its output power in a target sub-frame relatively to the power of the most recently transmitted reference sub-frame if the transmission gap between these sub-frames is  $\leq 20$  ms.

For PRACH transmission, the relative tolerance is the ability of the UE transmitter to set its output power relatively to the power of the most recently transmitted preamble. The measurement period for the PRACH preamble is specified in Table 6.3.4.2-1.

#### 6.3.5.2.1 Minimum requirements

The requirements specified in Table 6.3.5.2.1-1 apply when the power of the target and reference sub-frames are within the power range bounded by the Minimum output power as defined in subclause 6.3.2 and the measured PUMAX as defined in subclause 6.2.5 (i.e., the actual power as would be measured assuming no measurement error). This power shall be within the power limits specified in subclause 6.2.5.

To account for RF Power amplifier mode changes 2 exceptions are allowed for each of two test patterns. The test patterns are a monotonically increasing power sweep and a monotonically decreasing power sweep over a range bounded by the requirements of minimum power and maximum power specified in subclauses 6.3.2 and 6.2.2. For these exceptions the power tolerance limit is a maximum of  $\pm 6.0$  dB in Table 6.3.5.2.1-1

**Table 6.3.5.2.1-1 Relative power tolerance for transmission (normal conditions)**

Power step $\Delta P$ (Up or down) [dB]	All combinations of PUSCH and PUCCH transitions [dB]	All combinations of PUSCH/PUCCH and SRS transitions between sub- frames [dB]	PRACH [dB]
$\Delta P < 2$	$\pm 2.5$ (NOTE 3)	$\pm 3.0$	$\pm 2.5$
$2 \leq \Delta P < 3$	$\pm 3.0$	$\pm 4.0$	$\pm 3.0$
$3 \leq \Delta P < 4$	$\pm 3.5$	$\pm 5.0$	$\pm 3.5$
$4 \leq \Delta P \leq 10$	$\pm 4.0$	$\pm 6.0$	$\pm 4.0$
$10 \leq \Delta P < 15$	$\pm 5.0$	$\pm 8.0$	$\pm 5.0$
$15 \leq \Delta P$	$\pm 6.0$	$\pm 9.0$	$\pm 6.0$
NOTE 1: For extreme conditions an additional $\pm 2.0$ dB relaxation is allowed NOTE 2: For operating bands under NOTE 2 in Table 6.2.2-1, the relative power tolerance is relaxed by increasing the upper limit by 1.5 dB if the transmission bandwidth of the reference sub-frames is confined within $F_{UL\_low}$ and $F_{UL\_low} + 4$ MHz or $F_{UL\_high} - 4$ MHz and $F_{UL\_high}$ and the target sub-frame is not confined within any one of these frequency ranges; if the transmission bandwidth of the target sub-frame is confined within $F_{UL\_low}$ and $F_{UL\_low} + 4$ MHz or $F_{UL\_high} - 4$ MHz and $F_{UL\_high}$ and the reference sub-frame is not confined within any one of these frequency ranges, then the tolerance is relaxed by reducing the lower limit by 1.5 dB. NOTE 3: For PUSCH to PUSCH transitions with the allocated resource blocks fixed in frequency and no transmission gaps other than those generated by downlink subframes, DwPTS fields or Guard Periods for TDD: for a power step $\Delta P \leq 1$ dB, the relative power tolerance for transmission is $\pm 1.0$ dB.			

The power step ( $\Delta P$ ) is defined as the difference in the calculated setting of the UE Transmit power between the target and reference sub-frames with the power setting according to subclause 5.1 of [TS 36.213]. The error is the difference

between  $\Delta P$  and the power change measured at the UE antenna port with the power of the cell-specific reference signals kept constant. The error shall be less than the relative power tolerance specified in Table 6.3.5.2.1-1.

For sub-frames not containing an SRS symbol, the power change is defined as the relative power difference between the mean power of the original reference sub-frame and the mean power of the target subframe not including transient durations. The mean power of successive sub-frames shall be calculated according to Figure 6.3.4.3-1 and Figure 6.3.4.1-1 if there is a transmission gap between the reference and target sub-frames.

If at least one of the sub-frames contains an SRS symbol, the power change is defined as the relative power difference between the mean power of the last transmission within the reference sub-frame and the mean power of the first transmission within the target sub-frame not including transient durations. A transmission is defined as PUSCH, PUCCH or an SRS symbol. The mean power of the reference and target sub-frames shall be calculated according to Figures 6.3.4.1-1, 6.3.4.2-1, 6.3.4.4-1, 6.3.4.4-2 and 6.3.4.4-3 for these cases.

### 6.3.5.3 Aggregate power control tolerance

Aggregate power control tolerance is the ability of a UE to maintain its power in non-contiguous transmission within 21 ms in response to 0 dB TPC commands with respect to the first UE transmission, when the power control parameters specified in TS 36.213 are constant. For HD-FDD UEs that support coverage enhancement (CE), the requirements on aggregate power control tolerance in 6.3.5E.3 apply.

#### 6.3.5.3.1 Minimum requirement

The UE shall meet the requirements specified in Table 6.3.5.3.1-1 for aggregate power control over the power range bounded by the minimum output power as defined in subclause 6.3.2 and the maximum output power as defined in subclause 6.2.2.

**Table 6.3.5.3.1-1: Aggregate power control tolerance**

TPC command	UL channel	Aggregate power tolerance within 21 ms
0 dB	PUCCH	$\pm 2.5$ dB
0 dB	PUSCH	$\pm 3.5$ dB
NOTE: The UE transmission gap is 4 ms. TPC command is transmitted via PDCCH 4 subframes preceding each PUCCH/PUSCH transmission.		

### 6.3.5A Power control for CA

The requirements apply for one single PUCCH, PUSCH or SRS transmission of contiguous PRB allocation per component carrier with power setting in accordance with Clause 5.1 of [6].

#### 6.3.5A.1 Absolute power tolerance

The absolute power tolerance is the ability of the UE transmitter to set its initial output power to a specific value for the first sub-frame at the start of a contiguous transmission or non-contiguous transmission with a transmission gap on each active component carriers larger than 20ms. For component carriers with Frame Structure Type 3 the absolute power tolerance requirements apply when the said transmission gaps are larger than 40 ms. The requirement can be tested by time aligning any transmission gaps on the component carriers.

When SRS carrier based switching is used, then the above mentioned absolute power tolerance is the ability of the UE transmitter to set its initial output power to a specific value for the first sub-frame at the start of a contiguous transmission or non-contiguous transmission with a transmission gap on component carriers (to which SRS switching occurs) larger than 40ms.

##### 6.3.5A.1.1 Minimum requirements

For inter-band carrier aggregation with uplink assigned to two E-UTRA bands, the absolute power control tolerance is specified on each component carrier exceed the minimum output power as defined in subclause 6.3.2A and the total power is limited by maximum output power as defined in subclause 6.2.2A. The requirements defined in Table

6.3.5.1.1-1 shall apply on each component carrier with all component carriers active. The requirements can be tested by time aligning any transmission gaps on all the component carriers.

For intra-band contiguous carrier aggregation bandwidth class B, C and D and intra-band non-contiguous carrier aggregation the absolute power control tolerance per component carrier is given in Table 6.3.5.1.1-1.

## 6.3.5A.2 Relative power tolerance

### 6.3.5A.2.1 Minimum requirements

For inter-band carrier aggregation with uplink assigned to two E-UTRA bands, the relative power tolerance is specified when the power of the target and reference sub-frames on each component carrier exceed the minimum output power as defined in subclause 6.3.2A and the total power is limited by  $P_{UMAX}$  as defined in subclause 6.2.5A. The requirements shall apply on each component carrier with all component carriers active. The UE transmitter shall have the capability of changing the output power independently on all component carriers in the uplink and:

- a) the requirements for all combinations of PUSCH and PUCCH transitions per component carrier is given in Table 6.3.5.2.1-1.
- b) for SRS the requirements for combinations of PUSCH/PUCCH and SRS transitions between subframes given in Table 6.3.5.2.1-1 apply per component carrier when the target and reference subframes are configured for either simultaneous SRS or simultaneous PUSCH.
- c) for RACH the requirements apply for the primary cell and are given in Table 6.3.5.2.1-1.

For component carriers with Frame Structure Type 3 the requirements for the target sub-frame relative to the power of the most recently transmitted reference sub-frame shall be met with a transmission gap  $\leq 40$  ms.

For intra-band contiguous carrier aggregation bandwidth class B, C and D and intra-band non-contiguous carrier aggregation, the requirements apply when the power of the target and reference sub-frames on each component carrier exceed -20 dBm and the total power is limited by  $P_{UMAX}$  as defined in subclause 6.2.5A. For the purpose of these requirements, the power in each component carrier is specified over only the transmitted resource blocks.

The UE shall meet the following requirements for transmission on both assigned component carriers when the average transmit power per PRB is aligned across both assigned carriers in the reference sub-frame:

- a) for all possible combinations of PUSCH and PUCCH transitions per component carrier, the corresponding requirements given in Table 6.3.5.2.1-1;
- b) for SRS transitions on each component carrier, the requirements for combinations of PUSCH/PUCCH and SRS transitions given in Table 6.3.5.2.1-1 with simultaneous SRS of constant SRS bandwidth allocated in the target and reference subframes;
- c) for RACH on the primary component carrier, the requirements given in Table 6.3.5.2.1-1 for PRACH.

For a) and b) above, the power step  $\Delta P$  between the reference and target subframes shall be set by a TPC command and/or an uplink scheduling grant transmitted by means of an appropriate DCI Format.

For a), b) and c) above, two exceptions are allowed for each component carrier for a power per carrier ranging from -20 dBm to  $P_{UMAX,c}$  as defined in subclause 6.2.5. For these exceptions the power tolerance limit is  $\pm 6.0$  dB in Table 6.3.5.2.1-1.

## 6.3.5A.3 Aggregate power control tolerance

Aggregate power control tolerance is the ability of a UE to maintain its power in non-contiguous transmission within 21 ms in response to 0 dB TPC commands with respect to the first UE transmission, when the power control parameters specified in [6] are constant on all active component carriers.

### 6.3.5A.3.1 Minimum requirements

For inter-band carrier aggregation with uplink assigned to two E-UTRA bands, the aggregate power tolerance is specified on each component carrier exceed the minimum output power as defined in subclause 6.3.2A and the total power is limited by maximum output power as defined in subclause 6.2.2A. The requirements defined in Table

6.3.5.3.1-1 shall apply on each component carrier with all component carriers active. The requirements can be tested by time aligning any transmission gaps on both the component carriers.

For intra-band contiguous carrier aggregation bandwidth class B, C and D and intra-band non-contiguous carrier aggregation, the aggregate power tolerance per component carrier is given in Table 6.3.5.3.1-1 with either simultaneous PUSCH or simultaneous PUCCH-PUSCH (if supported by the UE) configured. The average power per PRB shall be aligned across both assigned carriers before the start of the test. The requirement can be tested with the transmission gaps time aligned between component carriers.

### 6.3.5B Power control for UL-MIMO

For UE supporting UL-MIMO, the power control tolerance applies to the sum of output power at each transmit antenna connector.

The power control requirements specified in subclause 6.3.5 apply to UE with two transmit antenna connectors in closed-loop spatial multiplexing scheme. The requirements shall be met with UL-MIMO configurations specified in Table 6.2.2B-2, wherein

- The Maximum output power requirements for UL-MIMO are specified in subclause 6.2.2B
- The Minimum output power requirements for UL-MIMO are specified in subclause 6.3.2B
- The requirements for configured transmitted power for UL-MIMO are specified in subclause 6.2.5B.

If UE is configured for transmission on single-antenna port, the requirements in subclause 6.3.5 apply.

### 6.3.5D Power Control for ProSe

When UE is configured for simultaneous E-UTRA ProSe sidelink and E-UTRA uplink transmissions for inter-band E-UTRA ProSe / E-UTRA bands specified in Table 5.5D-2, the requirements in subclause 6.3.5D apply for ProSe transmission and the requirements in subclause 6.3.5 apply for uplink transmission.

#### 6.3.5D.1 Absolute power tolerance

For ProSe transmissions, the absolute power tolerance requirements specified in subclause 6.3.5.1 shall apply for each ProSe transmission.

### 6.3.5E Power control for category M1 and M2

#### 6.3.5E.1 Absolute power tolerance

The absolute power tolerance requirements specified in subclause 6.3.5.1 apply, wherein

- The Maximum output power requirements are specified in subclause 6.2.2E
- The Minimum output power requirements are specified in subclause 6.3.2
- The requirements for configured transmitted power are specified in subclause 6.2.5.

#### 6.3.5E.2 Relative Power tolerance

The relative power tolerance requirements specified in subclause 6.3.5.2 apply, wherein

- The Maximum output power requirements are specified in subclause 6.2.2E
- The Minimum output power requirements are specified in subclause 6.3.2
- The requirements for configured transmitted power are specified in subclause 6.2.5.

### 6.3.5E.3 Aggregate power control tolerance

Aggregate power control tolerance is the ability of a UE to maintain its power in non-contiguous transmission in response to 0 dB TPC commands with respect to the first UE transmission, when the power control parameters specified in TS 36.213 are constant.

For category M1 and M2 TDD and FD-FDD UEs, the aggregate power control tolerance requirements specified in Table 6.3.5E.3.1-0 apply. For category M1 and M2 HD-FDD UEs and for continuous uplink transmissions of duration  $\leq 64$  ms, the aggregate power control tolerance requirements specified in Table 6.3.5E.3.1-0 apply.

For category M1 and M2 HD-FDD UEs and for continuous uplink transmissions of duration  $> 64$  ms, the aggregate power control tolerance requirements specified in Table 6.3.5E.3.1-1 apply.

#### 6.3.5E.3.1 Minimum requirement

The category M1 and M2 TDD and FD-FDD UEs shall meet the requirements specified in Table 6.3.5E.3.1-0 for aggregate power control over the power range bounded by the minimum output power as defined in subclause 6.3.2, the maximum output power as defined in subclause 6.2.2E, and the requirements for configured transmitted power are specified in subclause 6.2.5.

The category M1 and M2 HD-FDD UEs and for continuous uplink transmissions of duration  $\leq 64$  ms, shall meet the requirements specified in Table 6.3.5E.3.1-0 for aggregate power control over the power range bounded by the minimum output power as defined in subclause 6.3.2, the maximum output power as defined in subclause 6.2.2E, and the requirements for configured transmitted power are specified in subclause 6.2.5.

**Table 6.3.5E.3.1-0: Aggregate power control tolerance**

TPC command	UL channel	Aggregate power tolerance within 21 ms <sup>2</sup>
0 dB	PUCCH	$\pm 2.5$ dB
0 dB	PUSCH	$\pm 3.5$ dB
NOTE 1: The UE transmission gap is 4 ms for full-duplex FDD and TDD. For UE of half-duplex FDD with the channel bandwidth 5 MHz / 10 MHz / 15 MHz / 20 MHz, the transmission gap is 1 ms after subframe #4 and 7 ms after subframe #6. For UE of half-duplex FDD with the CBW 1.4 / 3 MHz, the transmission gap is 9 ms. TPC command is transmitted via MPDCCH 4 subframes preceding each PUCCH/PUSCH transmission. NOTE 2: For UE of half-duplex FDD with the CBW 1.4 / 3 MHz, the test interval is 41 ms.		

The category M1 and M2 HD-FDD UE and for continuous uplink transmissions of duration  $> 64$  ms shall meet the requirements specified in Table 6.3.5E.3.1-1 for aggregate power control over the power range bounded by the minimum output power as defined in subclause 6.3.2 and the maximum output power as defined in subclause 6.2.2E.

**Table 6.3.5E.3.1-1: Aggregate power control tolerance**

TPC command	UL channel	Aggregate power tolerance within 129 ms
0 dB	PUCCH	$\pm 2.5$ dB
0 dB	PUSCH	$\pm 3.5$ dB
NOTE: The UE transmission gap is 5 ms. TPC command is transmitted via MPDCCH 4 subframes preceding each PUCCH/ PUSCH transmission.		

### 6.3.5F Power Control for category NB1 and NB2

Power control requirements in this clause apply for category NB1 and NB2 UE.

### 6.3.5F.1 Absolute power tolerance

The minimum requirement for absolute power tolerance is given in Table 6.3.5F.1-1 over the power range bounded by the Maximum output power as defined in subclause 6.2.2F and the Minimum output power as defined in subclause 6.3.2F.

**Table 6.3.5F.1-1: Absolute power tolerance - I**

Conditions	Tolerance
Normal	$\pm 9.0$ dB
Extreme	$\pm 12.0$ dB

In case of  $-15 \text{ dB} \leq \hat{E}_s/\text{Tot} < -6 \text{ dB}$ , the absolute power tolerance given in Table 6.3.5F.1-2 applies if the UE transmit power is not mandated to be  $P_{\text{CMAX},c}$  according to the UE uplink power control procedure or random access procedure in Section 16 of [6] (e.g. the lowest configured repetition level is used for NPRACH transmission or the number of repetitions of the allocated NPUSCH RUs is no more than 2).

**Table 6.3.5F.1-2: Absolute power tolerance - II**

Conditions	Tolerance
Normal	$\pm 13.3$ dB
Extreme	$\pm 16.3$ dB

### 6.3.5F.2 Relative power tolerance

Category NB1 and NB2 UE relative power control requirement is defined for NPRACH power step values of 0, 2, 4 and 6 dB. For NPRACH transmission, the relative tolerance is the ability of the UE transmitter to set its output power relatively to the power of the most recently transmitted preamble. The measurement period for the NPRACH preamble is specified in Table 6.3.4F.2-1.

The requirements specified in Table 6.3.5F.2-1 apply when the power of the target and reference sub-frames are within the power range bounded by the Minimum output power as defined in subclause 6.3.2F and the maximum output power as defined in subclause 6.2.2F.

**Table 6.3.5F.2-1: Relative power tolerance for category NB1 and NB2 NPRACH transmission (normal conditions)**

Power step $\Delta P$ [dB]	NPRACH [dB]
$\Delta P = 0$	$\pm 1.5$
$\Delta P = 2$	$\pm 2.0$
$\Delta P = 4$	$\pm 3.5$
$\Delta P = 6$	$\pm 4.0$
NOTE: For extreme conditions an additional $\pm 2.0$ dB relaxation is allowed.	

The power step ( $\Delta P$ ) is defined as the difference in the calculated setting of the UE transmit power between the target and reference sub-frames. The error is the difference between  $\Delta P$  and the power change measured at the UE antenna port with the power of the cell-specific reference signals kept constant. The error shall be less than the relative power tolerance specified in Table 6.3.5F.2-1.

### 6.3.5F.3 Aggregate power control tolerance for category NB1 and NB2

Category NB1 and NB2 aggregate power control tolerance is the ability of a UE to maintain its output power in non-contiguous transmission with respect to the first UE transmission, when the uplink power control parameters as defined in TS 36.213 are constant and  $\alpha$  is set to 0.

#### 6.3.5F.3.1 Minimum requirement

The UE shall meet the requirements specified in Table 6.3.5F.3.1-1 for aggregate power control over the power range bounded by the minimum output power as defined in subclause 6.3.2F and the maximum output power as defined in subclause 6.2.2F.

**Table 6.3.5F.3.1-1: Aggregate power control tolerance for HD-FDD**

UL channel	Aggregate power tolerance	
	15 kHz / 12 tones within 53 ms	15 kHz / 1 tone within 104 ms
NPUSCH	±3.5 dB	
NOTE:	For five consecutive UE transmissions the transmission gaps are 12 ms for 12 tone and 16 ms for single tone transmissions. Uplink scheduling grant is transmitted via NPDCCH eight subframes before NPUSCH transmission.	

**Table 6.3.5F.3.1-2: Aggregate power control tolerance for TDD**

UL channel	Aggregate power tolerance	
	15 kHz / 12 tones within 81 ms	15 kHz / 1 tone within 177 ms
NPUSCH	±3.5 dB	
NOTE:	For five consecutive UE transmissions the transmission gaps are 19 ms for 12 tone and 23 ms for single tone transmissions. Uplink scheduling grant is transmitted via NPDCCH eight subframes before NPUSCH transmission.	

### 6.3.5G Power Control for V2X Communication

When UE is configured for E-UTRA V2X sidelink transmissions non-concurrent with E-UTRA uplink transmissions for E-UTRA V2X operating bands specified in Table Table 5.5G-1, the requirements in subclause 6.3.5G.1 apply for E-UTRA V2X sidelink transmission.

When UE is configured for simultaneous E-UTRA V2X sidelink and E-UTRA uplink transmissions for inter-band E-UTRA V2X / E-UTRA bands specified in Table 5.5G-2, the requirements in subclause 6.3.5G.1 apply for V2X sidelink transmission and the requirements in subclause 6.3.5 apply for the E-UTRA uplink transmission.

For V2X UE supporting Transmit Diversity, if the UE transmits on two antenna connectors at the same time, the power control tolerance for single carrier shall apply to the sum of output power at each transmit antenna connector.

If the UE transmit on one -antenna connector at a time, the requirements for single carrier shall apply to the active antenna connector.

#### 6.3.5G.1 Absolute power tolerance

Absolute power tolerance is the ability of the UE to set its output power to a specific value for each subframe.

For V2X sidelink communication transmissions in the operating bands specified in Table 5.5G-1, the minimum requirement for absolute power tolerance is given in Table 6.3.5G.1-1 over the power range bounded by the Maximum output power as defined in subclause 6.2.2G and the Minimum output power as defined in subclause 6.3.2G.

For operating bands under NOTE 2 in Table 6.2.2-1, the absolute power tolerance as specified in Table 6.3.5G.1-1 is relaxed by reducing the lower limit by 1.5 dB when the transmission bandwidth is confined within  $F_{UL\_low}$  and  $F_{UL\_low} + 4$  MHz or  $F_{UL\_high} - 4$  MHz and  $F_{UL\_high}$ .

**Table 6.3.5G.1-1: Absolute power tolerance**

Conditions	Tolerance
Normal	$\pm 9.0$ dB
Extreme	$\pm 12.0$ dB

For intra-band contiguous multi-carrier operation the absolute power control tolerance specified in Table 6.3.5G.1-1 shall apply for each component carrier.

## 6.4 Void

## 6.5 Transmit signal quality

### 6.5.1 Frequency error

The UE modulated carrier frequency shall be accurate to within  $\pm 0.1$  PPM observed over a period of one time slot (0.5 ms) compared to the carrier frequency received from the E-UTRA Node B

#### 6.5.1A Frequency error for CA

For inter-band carrier aggregation with uplink assigned to two E-UTRA bands, the frequency error requirements defined in subclause 6.5.1 shall apply on each component carrier with all component carriers active.

For intra-band contiguous carrier aggregation the UE modulated carrier frequencies per band shall be accurate to within  $\pm 0.1$  PPM observed over a period of one timeslot compared to the carrier frequency of primary component carrier received from the E-UTRA in the corresponding band.

For intra-band non-contiguous carrier aggregation the requirements in Section 6.5.1 applies per component carrier.

#### 6.5.1B Frequency error for UL-MIMO

For UE(s) supporting UL-MIMO, the UE modulated carrier frequency at each transmit antenna connector shall be accurate to within  $\pm 0.1$  PPM observed over a period of one time slot (0.5 ms) compared to the carrier frequency received from the E-UTRA Node B.

#### 6.5.1D Frequency error for ProSe

The UE modulated carrier frequency for ProSe sidelink transmissions shall be accurate to within  $\pm 0.1$  PPM observed over a period of one time slot (0.5 ms) compared to the carrier frequency received from the synchronization source. The synchronization source can be E-UTRA Node B or a ProSe UE transmitting sidelink synchronization signals.

When UE is configured for simultaneous E-UTRA ProSe sidelink and E-UTRA uplink transmissions for inter-band E-UTRA ProSe / E-UTRA bands specified in Table 5.5D-2, the requirements in subclause 6.5.1D apply for ProSe transmission and the requirements in subclause 6.5.1 apply for uplink transmission.

#### 6.5.1E Frequency error for UE category M1 and M2

For category M1 and M2 TDD UEs and FD-FDD UEs, the frequency error requirements in Clause 6.5.1 apply.

For category M1 and M2 HD-FDD UEs and for continuous uplink transmissions of duration  $\leq 64$  ms, the frequency error requirements in Clause 6.5.1 apply.



For category M1 and M2 HD-FDD UEs and for continuous uplink transmissions of duration > 64 ms, the UE modulated carrier frequency shall be accurate to within the limits in Table 6.5.1E-1 observed over a period of one time slot (0.5 ms) compared to the carrier frequency received from the E-UTRA Node B.

**Table 6.5.1E-1: Frequency error requirement for HD-FDD UE category M1 and M2**

Carrier frequency [GHz]	Frequency error [ppm]
≤1	±0.2
>1	±0.1

## 6.5.1F Frequency error for UE category NB1 and NB2

For UE category NB1 and NB2, the UE modulated carrier frequency shall be accurate to within the following limits

**Table 6.5.1F-1: Frequency error requirement for UE category NB1 and NB2**

Carrier frequency [GHz]	Frequency error [ppm]
≤1	±0.2
>1	±0.1

Observed over a period of one time slot (0.5 ms for 15 kHz sub-carrier spacing and 2 ms excluding the 2304Ts gap for 3.75 kHz sub-carrier spacing) and averaged over  $72/L_{C_{tone}}$  slots (where  $L_{C_{tone}} = \{1, 3, 6, 12\}$  is the number of sub-carriers used for the transmission), compared to the carrier frequency received from the E-UTRA Node B.

## 6.5.1G Frequency error for V2X Communication

The UE modulated carrier frequency for V2X sidelink transmissions shall be accurate to within ±0.1 PPM observed over a period of one time slot (0.5 ms) compared to the absolute frequency in case of using GNSS synchronization source. The same requirements applied over a period of one time slot (0.5 ms) compared to the relative frequency in case of using the E-UTRA Node B or V2X UE sidelink synchronization signals.

When UE is configured for simultaneous E-UTRA V2X sidelink and E-UTRA uplink transmissions for inter-band E-UTRA V2X / E-UTRA bands specified in Table 5.5G-2, the requirements in subclause 6.5.1G apply for V2X sidelink transmission and the requirements in subclause 6.5.1 apply for the E-UTRA uplink transmission.

For V2X UE supporting Transmit Diversity, if the UE transmits on two antenna connectors at the same time, the UE modulated carrier frequency at each transmit antenna connector shall be accurate to within ±0.1 PPM observed over a period of one time slot (0.5 ms) in case of using GNSS synchronization source. The same requirements applied over a period of one time slot (0.5 ms) compared to the relative frequency in case of using the E-UTRA Node B or V2X UE sidelink synchronization signals.

If the UE transmits on one antenna connector at a time, the requirements for single carrier shall apply to the active antenna connector.

## 6.5.2 Transmit modulation quality

Transmit modulation quality defines the modulation quality for expected in-channel RF transmissions from the UE. The transmit modulation quality is specified in terms of:

- Error Vector Magnitude (EVM) for the allocated resource blocks (RBs)
- EVM equalizer spectrum flatness derived from the equalizer coefficients generated by the EVM measurement process
- Carrier leakage
- In-band emissions for the non-allocated RB

All the parameters defined in subclause 6.5.2 are defined using the measurement methodology specified in Annex F.

### 6.5.2.1 Error Vector Magnitude

The Error Vector Magnitude is a measure of the difference between the reference waveform and the measured waveform. This difference is called the error vector. Before calculating the EVM the measured waveform is corrected by the sample timing offset and RF frequency offset. Then the carrier leakage shall be removed from the measured waveform before calculating the EVM.

The measured waveform is further modified by selecting the absolute phase and absolute amplitude of the Tx chain. The EVM result is defined after the front-end IDFT as the square root of the ratio of the mean error vector power to the mean reference power expressed as a %.

The basic EVM measurement interval in the time domain is one preamble sequence for the PRACH, and as specified in Table 6.5.2.1-1 for the PUCCH and PUSCH in the time domain. When the PUSCH or PUCCH transmission slot or subslot is shortened due to multiplexing with SRS, the EVM measurement interval is reduced by one symbol, accordingly. Likewise, when the PUSCH starting position is modified or when second last symbol is the ending symbol of the PUSCH subframe for Frame Structure Type 3, the EVM measurement interval is reduced accordingly. The PUSCH or PUCCH EVM measurement interval is also reduced when the mean power, modulation or allocation between slots or subslots is expected to change. In the case of PUSCH transmission, the measurement interval is reduced by a time interval equal to the sum of 5  $\mu$ s and the applicable exclusion period defined in subclause 6.3.4, adjacent to the boundary where the power change is expected to occur. The PUSCH exclusion period is applied to the signal obtained after the front-end IDFT. In the case of PUCCH transmission with power change, the PUCCH EVM measurement interval is reduced by one symbol adjacent to the boundary where the power change is expected to occur.

**Table 6.5.2.1-1: Measurement interval for EVM**

TTI pattern	Measurement interval
Subframe	7OS
Slot	7OS
Subslot	2OS, 3OS

#### 6.5.2.1.1 Minimum requirement

The RMS average of the basic EVM measurements for 10 subframes excluding any transient period for the average EVM case, and 60 subframes excluding any transient period for the reference signal EVM case, for the different modulations schemes shall not exceed the values specified in Table 6.5.2.1.1-1 for the parameters defined in Table 6.5.2.1.1-2. For EVM evaluation purposes, [all PRACH preamble formats 0-4 and] all PUCCH formats 1, 1a, 1b, 2, 2a and 2b are considered to have the same EVM requirement as QPSK modulated.

**Table 6.5.2.1.1-1: Minimum requirements for Error Vector Magnitude**

Parameter	Unit	Average EVM Level	Reference Signal EVM Level
QPSK or BPSK	%	17.5	17.5
16 QAM	%	12.5	12.5
64 QAM	%	8	8
256 QAM	%	3.5	3.5

**Table 6.5.2.1.1-2: Parameters for Error Vector Magnitude**

Parameter	Unit	Level
UE Output Power	dBm	$\geq -40$
UE Output Power for 256 QAM	dBm	$\geq -30$
Operating conditions		Normal conditions

#### 6.5.2.2 Carrier leakage

Carrier leakage is an additive sinusoid waveform that has the same frequency as a modulated waveform carrier frequency. The measurement interval is one slot in the time domain.

## 6.5.2.2.1 Minimum requirements

The relative carrier leakage power is a power ratio of the additive sinusoid waveform and the modulated waveform. The relative carrier leakage power shall not exceed the values specified in Table 6.5.2.2.1-1.

Table 6.5.2.2.1-1: Minimum requirements for relative carrier leakage power

Parameters	Relative limit (dBc)	Applicable frequencies
Output power >10 dBm	-28	Carrier center frequency < 1 GHz
	-25	Carrier center frequency ≥ 1 GHz
0 dBm ≤ Output power ≤ 10 dBm	-25	
-30 dBm ≤ Output power ≤ 0 dBm	-20	
-40 dBm ≤ Output power < -30 dBm (NOTE 1)	-10	
NOTE 1: The requirement in this power range is not applicable for V2X sidelink transmission for E-UTRA V2X operating bands specified in Table 5.5G-1.		

## 6.5.2.3 In-band emissions

The in-band emission is defined as the average across 12 sub-carrier and as a function of the RB offset from the edge of the allocated UL transmission bandwidth. The in-band emission is measured as the ratio of the UE output power in a non-allocated RB to the UE output power in an allocated RB.

The basic in-band emissions measurement interval is defined over one slot in the time domain. When the PUSCH or PUCCH transmission slot is shortened due to multiplexing with SRS, the in-band emissions measurement interval is reduced by one SC-FDMA symbol, accordingly. Likewise, when the PUSCH starting position is modified or when the second last symbol is the ending symbol of the PUSCH sub-frame for Frame Structure Type 3, the in-band emissions measurement interval is reduced accordingly.

## 6.5.2.3.1 Minimum requirements

The relative in-band emission shall not exceed the values specified in Table 6.5.2.3.1-1.

Table 6.5.2.3.1-1: Minimum requirements for in-band emissions

Parameter description	Unit	Limit (NOTE 1)		Applicable Frequencies
General	dB	For Frame Structure Type 1 and Frame Structure Type 2: $\max \left\{ -25 - 10 \cdot \log_{10} (N_{RB} / L_{CRB}), \right.$ $20 \cdot \log_{10} EVM - 3 - 5 \cdot ( \Delta_{RB}  - 1) / L_{CRB},$ $\left. -57 \text{ dBm} / 180 \text{ kHz} - P_{RB} \right\}$ For Frame Structure Type 3, 10 MHz and 20 MHz channel bandwidths: $\max \left\{ -10 - 6( \Delta_{RB}  - 1), \right.$ $\left. -57 \text{ dBm} / 180 \text{ kHz} - P_{RB} \right\}$		Any non-allocated (NOTE 2)
		-28	Image frequencies when carrier center frequency < 1 GHz and Output power > 10 dBm	
IQ Image	dB	-25	Image frequencies when carrier center frequency < 1 GHz and Output power ≤ 10 dBm	Image frequencies (NOTES 2, 3)
		-25	Image frequencies when carrier center frequency ≥ 1 GHz	
Carrier leakage	dBc	-28	Output power > 10 dBm and carrier center frequency < 1 GHz	Carrier frequency (NOTES 4, 5)
		-25	Output power > 10 dBm and carrier center frequency ≥ 1 GHz	
		-25	0 dBm ≤ Output power ≤ 10 dBm	
		-20	-30 dBm ≤ Output power ≤ 0 dBm	
		-10	-40 dBm ≤ Output power < -30 dBm (NOTE 12)	

NOTE 1:	An in-band emissions combined limit is evaluated in each non-allocated RB. For each such RB, the minimum requirement is calculated as the higher of $P_{RB} - 30$ dB and the power sum of all limit values (General, IQ Image or Carrier leakage) that apply. $P_{RB}$ is defined in NOTE 10.
NOTE 2:	The measurement bandwidth is 1 RB and the limit is expressed as a ratio of measured power in one non-allocated RB to the measured average power per allocated RB, where the averaging is done across all allocated RBs. For Frame Structure Type 3 and 20 MHz channel bandwidth, the requirement applies for QPSK, 16QAM and 64QAM modulation with $ \Delta_{RB}  \leq 5$ for any non-allocated RB and $RIV = 1$ in the uplink scheduling grant with $RIV$ specified in [6]. For Frame Structure Type 3 and 10 MHz channel bandwidth in Band 49, the requirement applies for QPSK, 16QAM and 64QAM modulation with $ \Delta_{RB}  \leq 3$ for any non-allocated RB and $RIV = 01000$ in the uplink scheduling grant.
NOTE 3:	The applicable frequencies for this limit are those that are enclosed in the reflection of the allocated bandwidth, based on symmetry with respect to the centre carrier frequency, but excluding any allocated RBs. For Frame Structure Type 3 with 20 MHz channel bandwidth, the applicable frequency is $n_{PRB} = 98$ for QPSK, 16QAM and 64QAM modulation. For Frame Structure Type 3 and 10 MHz channel bandwidth in Band 49, the applicable frequency is $n_{PRB} = 48$ for QPSK, 16QAM and 64QAM modulation.
NOTE 4:	The measurement bandwidth is 1 RB and the limit is expressed as a ratio of measured power in one non-allocated RB to the measured total power in all allocated RBs. For Frame Structure Type 3 and 20 MHz channel bandwidth, the requirement applies for QPSK, 16QAM and 64QAM modulation with $RIV = 5$ in the uplink scheduling grant. For Frame Structure Type 3 and 10 MHz channel bandwidth in Band 49, the requirement applies for QPSK, 16QAM and 64QAM modulation with $RIV = 00100$ in the uplink scheduling grant.
NOTE 5:	The applicable frequencies for this limit are those that are enclosed in the RBs containing the DC frequency if $N_{RB}$ is odd, or in the two RBs immediately adjacent to the DC frequency if $N_{RB}$ is even, but excluding any allocated RB.
NOTE 6:	$L_{CRB}$ is the Transmission Bandwidth (see Figure 5.6-1).
NOTE 7:	$N_{RB}$ is the Transmission Bandwidth Configuration (see Figure 5.6-1).
NOTE 8:	$EVM$ is the limit specified in Table 6.5.2.1.1-1 for the modulation format used in the allocated RBs.
NOTE 9:	$\Delta_{RB}$ is the starting frequency offset between the allocated RB and the measured non-allocated RB (e.g. $\Delta_{RB} = 1$ or $\Delta_{RB} = -1$ for the first adjacent RB outside of the allocated bandwidth).
NOTE 10:	$P_{RB}$ is the transmitted power per 180 kHz in allocated RBs, measured in dBm.
[NOTE 11:	For V2V-V2X waveforms, the requirements are applied when PSSCH and PSCCH are adjacent in frequency. The limit values (General, IQ Image or Carrier leakage) of each channel is calculated separately as $P_{general, PSSCH}$ , $P_{IQ, PSSCH}$ , $P_{LO, PSSCH}$ , $P_{general, PSCCH}$ , $P_{IQ, PSCCH}$ , $P_{LO, PSCCH}$ , respectively. In-band emissions combined limit is evaluated in each non-allocated RB. For each such RB, the minimum requirement is calculated as the higher of $P_{RB, PSSCH} - 30$ dB and the $P_{sumIBE, SSCH}$ , where $P_{sumIBE, SSCH}$ is the linear sum of $P_{general, PSSCH}$ , $P_{IQ, PSSCH}$ , $P_{LO, PSSCH}$ , $P_{general, PSCCH}$ , $P_{IQ, PSCCH}$ , $P_{LO, PSCCH}$ .]
NOTE 12:	The requirement in this power range is not applicable for V2X sidelink transmission for E-UTRA V2X operating bands specified in Table 5.5G-1.

NOTE: For Frame Structure 3 and operations in Band 46, in-band emissions requirements are not specified for the 10 MHz channel bandwidth.

#### 6.5.2.4 EVM equalizer spectrum flatness

The zero-forcing equalizer correction applied in the EVM measurement process (as described in Annex F) must meet a spectral flatness requirement for the EVM measurement to be valid. The EVM equalizer spectrum flatness is defined in terms of the maximum peak-to-peak ripple of the equalizer coefficients (dB) across the allocated uplink block. The basic measurement interval is the same as for EVM.

##### 6.5.2.4.1 Minimum requirements

The peak-to-peak variation of the EVM equalizer coefficients contained within the frequency range of the uplink allocation shall not exceed the maximum ripple specified in Table 6.5.2.4.1-1 for normal conditions. For uplink allocations contained within both Range 1 and Range 2, the coefficients evaluated within each of these frequency ranges shall meet the corresponding ripple requirement and the following additional requirement: the relative difference between the maximum coefficient in Range 1 and the minimum coefficient in Range 2 must not be larger than 5 dB,

and the relative difference between the maximum coefficient in Range 2 and the minimum coefficient in Range 1 must not be larger than 7 dB (see Figure 6.5.2.4.1-1).

The EVM equalizer spectral flatness shall not exceed the values specified in Table 6.5.2.4.1-2 for extreme conditions. For uplink allocations contained within both Range 1 and Range 2, the coefficients evaluated within each of these frequency ranges shall meet the corresponding ripple requirement and the following additional requirement: the relative difference between the maximum coefficient in Range 1 and the minimum coefficient in Range 2 must not be larger than 6 dB, and the relative difference between the maximum coefficient in Range 2 and the minimum coefficient in Range 1 must not be larger than 10 dB (see Figure 6.5.2.4.1-1).

**Table 6.5.2.4.1-1: Minimum requirements for EVM equalizer spectrum flatness (normal conditions)**

Frequency range	Maximum ripple [dB]
$F_{UL\_Meas} - F_{UL\_Low} \geq 3$ MHz and $F_{UL\_High} - F_{UL\_Meas} \geq 3$ MHz (Range 1)	4 (p-p)
$F_{UL\_Meas} - F_{UL\_Low} < 3$ MHz or $F_{UL\_High} - F_{UL\_Meas} < 3$ MHz (Range 2)	8 (p-p)
NOTE 1: $F_{UL\_Meas}$ refers to the sub-carrier frequency for which the equalizer coefficient is evaluated	
NOTE 2: $F_{UL\_Low}$ and $F_{UL\_High}$ refer to each E-UTRA frequency band specified in Table 5.5-1	

**Table 6.5.2.4.1-2: Minimum requirements for EVM equalizer spectrum flatness (extreme conditions)**

Frequency range	Maximum Ripple [dB]
$F_{UL\_Meas} - F_{UL\_Low} \geq 5$ MHz and $F_{UL\_High} - F_{UL\_Meas} \geq 5$ MHz (Range 1)	4 (p-p)
$F_{UL\_Meas} - F_{UL\_Low} < 5$ MHz or $F_{UL\_High} - F_{UL\_Meas} < 5$ MHz (Range 2)	12 (p-p)
NOTE 1: $F_{UL\_Meas}$ refers to the sub-carrier frequency for which the equalizer coefficient is evaluated	
NOTE 2: $F_{UL\_Low}$ and $F_{UL\_High}$ refer to each E-UTRA frequency band specified in Table 5.5-1	

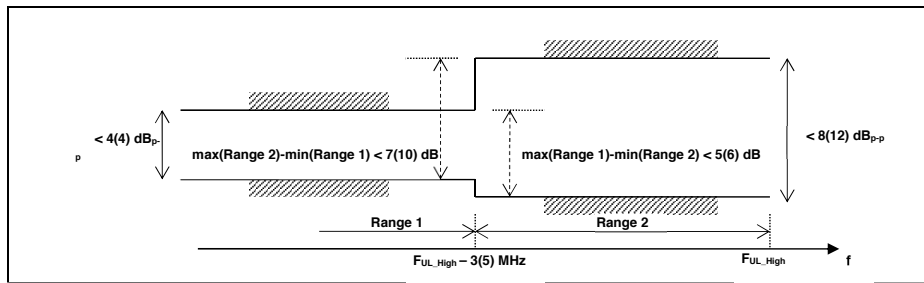

**Figure 6.5.2.4.1-1: The limits for EVM equalizer spectral flatness with the maximum allowed variation of the coefficients indicated (the ETC minimum requirement within brackets).**

### 6.5.2A Transmit modulation quality for CA

For inter-band carrier aggregation with uplink assigned to two E-UTRA bands, the requirements shall apply on each component carrier as defined in clause 6.5.2 with all component carriers active. If two contiguous component carriers are assigned to one E-UTRA band, the requirements in subclauses 6.5.2A.1, 6.5.2A.2, and 6.5.2A.3 apply for those component carriers.

The requirements in this clause apply with PCC and SCC in the UL configured and activated: PCC with PRB allocation and SCC without PRB allocation and without CSI reporting and SRS configured.

### 6.5.2A.1 Error Vector Magnitude

For the intra-band contiguous and non-contiguous carrier aggregation, the Error Vector Magnitude requirement should be defined for each component carrier. Requirements only apply with PRB allocation in one of the component carriers. Similar transmitter impairment removal procedures are applied for CA waveform before EVM calculation as is specified for non-CA waveform in sub-section 6.5.2.1.

When a single component carrier is configured Table 6.5.2.1.1-1 apply.

The EVM requirements are according to Table 6.5.2A.1-1 if CA is configured in uplink with the parameters defined in Table 6.5.2.1.1-2.

**Table 6.5.2A.1-1: Minimum requirements for Error Vector Magnitude**

Parameter	Unit	Average EVM Level per CC	Reference Signal EVM Level
QPSK or BPSK	%	17.5	17.5
16 QAM	%	12.5	12.5
64 QAM	%	8	8
256 QAM	%	3.5	3.5

### 6.5.2A.2 Carrier leakage for CA

Carrier leakage is an additive sinusoid waveform that is confined within the aggregated transmission bandwidth configuration. The carrier leakage requirement is defined for each component carrier and is measured on the component carrier with PRBs allocated. The measurement interval is one slot in the time domain.

#### 6.5.2A.2.1 Minimum requirements

The relative carrier leakage power is a power ratio of the additive sinusoid waveform and the modulated waveform. The relative carrier leakage power shall not exceed the values specified in Table 6.5.2A.2.1-1.

**Table 6.5.2A.2.1-1: Minimum requirements for Relative Carrier Leakage Power**

Parameters	Relative Limit (dBc)
Output power >0 dBm	-25
-30 dBm ≤ Output power ≤ 0 dBm	-20
-40 dBm ≤ Output power < -30 dBm	-10

### 6.5.2A.3 In-band emissions

#### 6.5.2A.3.1 Minimum requirement for CA

For intra-band contiguous carrier aggregation bandwidth class B, C and D, the requirements in Table 6.5.2A.3.1-1 and 6.5.2A.3.1-2 apply within the aggregated transmission bandwidth configuration with both component carrier (s) active and one single contiguous PRB allocation of bandwidth  $L_{CRB}$  at the edge of the aggregated transmission bandwidth configuration.

The inband emission is defined as the interference falling into the non allocated resource blocks for all component carriers. The measurement method for the inband emissions in the component carrier with PRB allocation is specified in annex F. For a non allocated component carrier a spectral measurement is specified.

For intra-band non-contiguous carrier aggregation the requirements for in-band emissions should be defined for each component carrier. Requirements only apply with PRB allocation in one of the component carriers according to Table 6.5.2.3.1.

**Table 6.5.2A.3.1-1: Minimum requirements for in-band emissions (allocated component carrier)**

Parameter	Unit	Limit	Applicable Frequencies	
General	dB	$\max \left\{ -25 - 10 \cdot \log_{10} (N_{RB} / L_{CRB}), \right.$ $20 \cdot \log_{10} EVM - 3 - 5 \cdot ( \Delta_{RB}  - 1) / L_{CRB},$ $\left. -57 \text{ dBm} / 180 \text{ kHz} - P_{RB} \right\}$	Any non-allocated (NOTE 2)	
IQ Image	dB	-25	Exception for IQ image (NOTE 3)	
Carrier leakage	dBc	-25	Exception for Carrier frequency (NOTE 4)	
		Output power > 0 dBm		
		-20		-30 dBm ≤ Output power ≤ 0 dBm
		-10	-40 dBm ≤ Output power < -30 dBm	
<p>NOTE 1: An in-band emissions combined limit is evaluated in each non-allocated RB. For each such RB, the minimum requirement is calculated as the higher of <math>P_{RB} - 30</math> dB and the power sum of all limit values (General, IQ Image or Carrier leakage) that apply. <math>P_{RB}</math> is defined in NOTE 9. The limit is evaluated in each non-allocated RB.</p> <p>NOTE 2: The measurement bandwidth is 1 RB and the limit is expressed as a ratio of measured power in one non-allocated RB to the measured average power per allocated RB, where the averaging is done across all allocated RBs</p> <p>NOTE 3: Exceptions to the general limit are allowed for up to <math>L_{CRBs} + 1</math> RBs within a contiguous width of <math>L_{CRBs} + 1</math> non-allocated RBs. The measurement bandwidth is 1 RB.</p> <p>NOTE 4: Exceptions to the general limit are allowed for up to two contiguous non-allocated RBs. The measurement bandwidth is 1 RB and the limit is expressed as a ratio of measured power in the non-allocated RB to the measured total power in all allocated RBs.</p> <p>NOTE 5: <math>L_{CRB}</math> is the Transmission Bandwidth (see Figure 5.6-1) not exceeding <math>N_{RB} / 2 - 1</math></p> <p>NOTE 6: <math>N_{RB}</math> is the Transmission Bandwidth Configuration (see Figure 5.6-1) of the component carrier with RBs allocated.</p> <p>NOTE 7: <math>EVM</math> is the limit specified in Table 6.5.2.1.1-1 for the modulation format used in the allocated RBs.</p> <p>NOTE 8: <math>\Delta_{RB}</math> is the starting frequency offset between the allocated RB and the measured non-allocated RB (e.g. <math>\Delta_{RB} = 1</math> or <math>\Delta_{RB} = -1</math> for the first adjacent RB outside of the allocated bandwidth).</p> <p>NOTE 9: <math>P_{RB}</math> is the transmitted power per 180 kHz in allocated RBs, measured in dBm.</p> <p>NOTE 10: For V2X intra-band contiguous multi-carrier operation the in-band emission requirement (General, IQ Image or Carrier leakage) of each channel is calculated separately as <math>P_{general, PSSCH,c(i)}</math>, <math>P_{IQ, PSSCH,c(i)}</math>, <math>P_{LO, PSSCH,c(i)}</math>, <math>P_{general, PSCCH,c(i)}</math>, <math>P_{IQ, PSCCH,c(i)}</math>, <math>P_{LO, PSCCH,c(i)}</math> for each carrier respectively. In-band emissions combined limit for the aggregated bandwidth is evaluated in each non-allocated RB. For each such RB, the minimum requirement is calculated as the <math>P_{sumIBE,CA}</math>, where <math>P_{sumIBE,CA}</math> is the linear sum of <math>P_{general, PSSCH,c(i)}</math>, <math>P_{IQ, PSSCH,c(i)}</math>, <math>P_{LO, PSSCH,c(i)}</math>, <math>P_{general, PSCCH,c(i)}</math>, <math>P_{IQ, PSCCH,c(i)}</math>, <math>P_{LO, PSCCH,c(i)}</math> for all carriers.</p>				

Table 6.5.2A.3.1-2: Minimum requirements for in-band emissions (not allocated component carrier)

Parameter	Unit	Meas BW NOTE 1	Limit	remark	Applicable Frequencies	
General	dB	BW of 1 RB (180KHz rectangular)	$\max \left\{ -25 - 10 \cdot \log_{10} (N_{RB} / L_{CRB}), \right.$ $20 \cdot \log_{10} EVM - 3 - 5 \cdot (\Delta_{RB} - 1) / L_{CRB},$ $\left. -57 \text{ dBm} / 180 \text{ kHz} - P_{RB} \right\}$	The reference value is the average power per allocated RB in the allocated component carrier	Any RB in the non allocated component carrier. The frequency raster of the RBs is derived when this component carrier is allocated with RBs	
IQ Image	dB	BW of 1 RB (180KHz rectangular)	-25 NOTE 2	The reference value is the average power per allocated RB in the allocated component carrier	The frequencies of the $L_{CRB}$ contiguous non-allocated RBs are unknown. The frequency raster of the RBs is derived when this component carrier is allocated with RBs	
Carrier leakage	dBc	BW of 1 RB (180KHz rectangular)	NOTE 3		The reference value is the total power of the allocated RBs in the allocated component carrier	The frequencies of the up to 2 non-allocated RBs are unknown. The frequency raster of the RBs is derived when this component carrier is allocated with RBs
			-25	Output power > 0 dBm		
			-20	-30 dBm ≤ Output power ≤ 0 dBm		
			-10	-40 dBm ≤ Output power < -30 dBm		
<p>NOTE 1: Resolution BWs smaller than the measurement BW may be integrated to achieve the measurement bandwidth.</p> <p>NOTE 2: Exceptions to the general limit is are allowed for up to <math>L_{CRB} + 1</math> RBs within a contiguous width of <math>L_{CRB} + 1</math> non-allocated RBs.</p> <p>NOTE 3: Two Exceptions to the general limit are allowed for up to two contiguous non-allocated RBs</p> <p>NOTE 4: NOTES 1, 5, 6, 7, 8, 9 from Table 6.5.2A.3.1-1 apply for Table 6.5.2A.3.1-2 as well.</p> <p>NOTE 5: <math>\Delta_{RB}</math> for measured non-allocated RB in the non allocated component carrier may take non-integer values when the carrier spacing between the CCs is not a multiple of RB.</p> <p>NOTE 6: For V2X intra-band contiguous multi-carrier operation the in-band emission requirement (General, IQ Image or Carrier leakage) of each channel is calculated separately as <math>P_{general, PSSCH, c(i)}</math>, <math>P_{IQ, PSSCH, c(i)}</math>, <math>P_{LO, PSSCH, c(i)}</math>, <math>P_{general, PSCCH, c(i)}</math>, <math>P_{IQ, PSCCH, c(i)}</math>, <math>P_{LO, PSCCH, c(i)}</math> for each carrier respectively. In-band emissions combined limit for the aggregated bandwidth is evaluated in each non-allocated RB. For each such RB, the minimum requirement is calculated as the <math>P_{sumIBE, CA}</math>, where <math>P_{sumIBE, CA}</math> is the linear sum of <math>P_{general, PSSCH, c(i)}</math>, <math>P_{IQ, PSSCH, c(i)}</math>, <math>P_{LO, PSSCH, c(i)}</math>, <math>P_{general, PSCCH, c(i)}</math>, <math>P_{IQ, PSCCH, c(i)}</math>, <math>P_{LO, PSCCH, c(i)}</math> for all carriers.</p>						



## 6.5.2B Transmit modulation quality for UL-MIMO

For UE supporting UL-MIMO, the transmit modulation quality requirements are specified at each transmit antenna connector.

If UE is configured for transmission on single-antenna port, the requirements in subclause 6.5.2 apply.

The transmit modulation quality is specified in terms of:

- Error Vector Magnitude (EVM) for the allocated resource blocks (RBs)
- EVM equalizer spectrum flatness derived from the equalizer coefficients generated by the EVM measurement process
- Carrier leakage (caused by IQ offset)
- In-band emissions for the non-allocated RB

### 6.5.2B.1 Error Vector Magnitude

For UE with two transmit antenna connectors in closed-loop spatial multiplexing scheme, the Error Vector Magnitude requirements specified in Table 6.5.2.1.1-1 which is defined in subclause 6.5.2.1 apply at each transmit antenna connector. The requirements shall be met with the UL-MIMO configurations specified in Table 6.2.2B-2.

### 6.5.2B.2 Carrier leakage

For UE with two transmit antenna connectors in closed-loop spatial multiplexing scheme, the Relative Carrier Leakage Power requirements specified in Table 6.5.2.2.1-1 which is defined in subclause 6.5.2.2 apply at each transmit antenna connector. The requirements shall be met with the UL-MIMO configurations specified in Table 6.2.2B-2.

### 6.5.2B.3 In-band emissions

For UE with two transmit antenna connectors in closed-loop spatial multiplexing scheme, the In-band Emission requirements specified in Table 6.5.2.3.1-1 which is defined in subclause 6.5.2.3 apply at each transmit antenna connector. The requirements shall be met with the uplink MIMO configurations specified in Table 6.2.2B-2.

### 6.5.2B.4 EVM equalizer spectrum flatness for UL-MIMO

For UE with two transmit antenna connectors in closed-loop spatial multiplexing scheme, the EVM Equalizer Spectrum Flatness requirements specified in Table 6.5.2.4.1-1 and Table 6.5.2.4.1-2 which are defined in subclause 6.5.2.4 apply at each transmit antenna connector. The requirements shall be met with the UL-MIMO configurations specified in Table 6.2.2B-2.

## 6.5.2D Transmit modulation quality for ProSe

The requirements in this clause apply to ProSe sidelink transmissions.

When UE is configured for simultaneous E-UTRA ProSe sidelink and E-UTRA uplink transmissions for inter-band E-UTRA ProSe / E-UTRA bands specified in Table 5.5D-2, the requirements in subclause 6.5.2D apply for ProSe transmission and the requirements in subclause 6.5.2 apply for uplink transmission.

### 6.5.2D.1 Error Vector Magnitude

For ProSe sidelink physical channels PSDCH, PSCCH, PSSCH, and PSBCH, the Error Vector Magnitude requirements shall be as specified for PUSCH in subclause 6.5.2.1 for the corresponding modulation and transmission bandwidth. When ProSe transmissions are shortened due to transmission gap of 1 symbol at the end of the subframe, the EVM measurement interval is reduced by one symbol, accordingly.

For PSBCH the duration over which EVM is averaged shall be 24 subframes.

This requirement is not applicable for ProSe physical signals PSSS and SSSS.

### 6.5.2D.2 Carrier leakage

The requirements of subclause 6.5.2.2 shall apply for ProSe transmissions.

### 6.5.2D.3 In-band emissions

For ProSe sidelink physical channels PSDCH, PSCCH, PSSCH, and PSBCH, the In-band emissions requirements shall be as specified for PUSCH in subclause 6.5.2.3 for the corresponding modulation and transmission bandwidth. When ProSe transmissions are shortened due to transmission gap of 1 symbol at the end of the subframe, the In-band emissions measurement interval is reduced by one symbol, accordingly.

### 6.5.2D.4 EVM equalizer spectrum flatness for ProSe

The requirements of subclause 6.5.2.4 shall apply for ProSe transmissions.

## 6.5.2E Transmit modulation quality for category M1 and M2

### 6.5.2E.1 Error Vector Magnitude

The Error Vector Magnitude is defined in section 6.5.2.1.

### 6.5.2E.2 Carrier leakage

Carrier leakage is an additive sinusoid waveform that has the same frequency as a modulated waveform carrier frequency. For UE of UL Categories M1 and M2, the sinusoid waveform may lie at the center of the narrowband assigned for transmission. The measurement interval is one slot in the time domain.

#### 6.5.2E.2.1 Minimum requirements

The relative carrier leakage power is a power ratio of the additive sinusoid waveform and the modulated waveform. The relative carrier leakage power at the center of the channel bandwidth or the center of the narrowband assigned for transmission shall not exceed the values specified in Table 6.5.2.2.1-1.

### 6.5.2E.3 In-band emissions

The in-band emission is defined in clause 6.5.2.3 and measurement condition specified in Annex F.

#### 6.5.2E.3.1 Minimum requirements

The relative in-band emission when the center carrier frequency is either at the center of channel bandwidth or at the center of the narrowband assigned for transmission shall not exceed the values specified in Table 6.5.2E.3.1-1

Table 6.5.2E.3.1-1: Minimum requirements for in-band emissions

Parameter description	Unit	Limit (NOTE 1)		Applicable Frequencies
General	dB	$-18 - [5] \cdot ( \Delta_{SubG}  - 1) / L_{SCG}$		Any non-allocated Subcarrier Group within the subPRB allocation (NOTE 11,12,13)
		$\max \left\{ -25 - 10 \cdot \log_{10} (N_{RB} / L_{CRB}), \right.$ $20 \cdot \log_{10} EVM - 3 - 5 \cdot ( \Delta_{RB}  - 1) / L_{CRB},$ $\left. -57 \text{ dBm} / 180 \text{ kHz} - P_{RB} \right\}$		Any non-allocated (NOTE 2)
IQ Image	dB	-28	Image frequencies when carrier center frequency < 1 GHz and Output power > 10 dBm	Image frequencies (NOTES 2, 3)
		-25	Image frequencies when carrier center frequency < 1 GHz and Output power ≤ 10 dBm	
		-25	Image frequencies when carrier center frequency ≥ 1 GHz	
Carrier leakage	dBc	-28	Output power > 10 dBm and carrier center frequency < 1 GHz	Carrier frequency (NOTES 4, 5)
		-25	Output power > 10 dBm and carrier center frequency ≥ 1 GHz	
		-25	0 dBm ≤ Output power ≤ 10 dBm	
		-20	-30 dBm ≤ Output power ≤ 0 dBm	
		-10	-40 dBm ≤ Output power < -30 dBm	
<p>NOTE 1: An in-band emissions combined limit is evaluated in each non-allocated RB. For each such RB, the minimum requirement is calculated as the higher of <math>P_{RB} - 30</math> dB and the power sum of all limit values (General, IQ Image or Carrier leakage) that apply. <math>P_{RB}</math> is defined in NOTE 10.</p> <p>NOTE 2: The measurement bandwidth is 1 RB and the limit is expressed as a ratio of measured power in one non-allocated RB to the measured average power per allocated RB, where the averaging is done across all allocated RBs.</p> <p>NOTE 3: The applicable frequencies for this limit are those that are enclosed in the reflection of the allocated bandwidth, based on symmetry with respect to the centre carrier frequency, but excluding any allocated RBs. For UE of UL Categories M1 and M2, the applicable frequencies shall alternatively include those found by reflection on the center of the assigned narrowband, but excluding any allocated RBs.</p> <p>NOTE 4: The measurement bandwidth is 1 RB and the limit is expressed as a ratio of measured power in one non-allocated RB to the measured total power in all allocated RBs.</p> <p>NOTE 5: The applicable frequencies for this limit are those that are enclosed in the RBs containing the DC frequency if <math>N_{RB}</math> is odd, or in the two RBs immediately adjacent to the DC frequency if <math>N_{RB}</math> is even, but excluding any allocated RB. For UE of UL Categories M1 and M2, the applicable frequencies shall alternatively be the centre frequency of the supported 6RBs.</p> <p>NOTE 6: <math>L_{CRB}</math> is the Transmission Bandwidth (see Figure 5.6-1).</p> <p>NOTE 7: <math>N_{RB}</math> is the Transmission Bandwidth Configuration (see Figure 5.6-1).</p> <p>NOTE 8: <math>EVM</math> is the limit specified in Table 6.5.2.1.1-1 for the modulation format used in the allocated RBs.</p> <p>NOTE 9: <math>\Delta_{RB}</math> is the starting frequency offset between the allocated RB and the measured non-allocated RB (e.g. <math>\Delta_{RB} = 1</math> or <math>\Delta_{RB} = -1</math> for the first adjacent RB outside of the allocated bandwidth).</p> <p>NOTE 10: <math>P_{RB}</math> is the transmitted power per 180 kHz in allocated RBs, measured in dBm.</p> <p>NOTE 11: The measurement bandwidth is 1 subcarrier group ( [3] subcarrier per subcarrier group) and the limit is expressed as a ratio of measured power in one non-allocated subcarrier group to the measured total power in all allocated subcarrier.</p> <p>NOTE 12: <math>\Delta_{SubG}</math> is the starting frequency offset between the allocated subcarrier group and the measured non-allocated subcarrier group (e.g. <math>\Delta_{SubG} = 1</math> or <math>\Delta_{SubG} = -1</math> for the first adjacent subcarrier group outside the allocated subcarrier group.)</p> <p>NOTE 13: <math>L_{SCG}</math> is the Transmission bandwidth (number of subcarrier group).</p>				

## 6.5.2F Transmit modulation quality for Category NB1 and NB2

### 6.5.2F.1 Error Vector Magnitude

The RMS average of the basic EVM measurements for  $240/L_{Ctone}$  slots excluding any transient period for the average EVM case, where  $L_{Ctone} = \{1, 3, 6, 12\}$  is the number of subcarriers for the category NB1 and NB2 transmission, for the different modulations schemes shall not exceed the values specified in Table 6.5.2.1.1-1 for the parameters defined in Table 6.5.2.1.1-2. For EVM evaluation purposes, both NPRACH formats are considered to have the same EVM requirement as QPSK modulated.

### 6.5.2F.2 Carrier leakage

Carrier leakage is an additive sinusoid waveform that has the same frequency as a modulated waveform carrier frequency. The measurement interval is one slot in the time domain. The relative carrier leakage power is a power ratio of the additive sinusoid waveform and the modulated waveform. The relative carrier leakage power of category NB1 or NB2 UE shall not exceed the values specified in Table 6.5.2F.2-1.

**Table 6.5.2F.2-1: Minimum requirements for relative carrier leakage power**

Parameters	Relative limit (dBc)
$0 \text{ dBm} \leq \text{Output power}$	-25
$-30 \text{ dBm} \leq \text{Output power} \leq 0 \text{ dBm}$	-20
$-40 \text{ dBm} \leq \text{Output power} < -30 \text{ dBm}$	-10

### 6.5.2F.3 In-band emissions

The in-band emission is defined as a function of the tone offset from the edge of the allocated UL transmission tone(s) within the transmission bandwidth configuration. The in-band emission is measured as the ratio of the UE output power in a non-allocated tone to the UE output power in an allocated tone. The basic in-band emissions measurement interval is defined over one slot in the time domain.

The category NB1 and NB2 UE relative in-band emission shall not exceed the values specified in Table 6.5.2F.3-1.

Table 6.5.2F.3-1: Minimum requirements for in-band emissions

Parameter description	Unit	Limit (NOTE 1)		Applicable Frequencies
General	dB	$\max \left\{ -15 - 10 \cdot \log_{10} (N_{\text{tone}} / L_{C\text{tone}}), \right.$ $-18 - 5 \cdot (\Delta_{\text{tone}}   - 1) / L_{C\text{tone}},$ $\left. -57 \text{ dBm} / (3.75 \text{ kHz or } 15 \text{ kHz}) - P_{\text{tone}} \right\}$		Any non-allocated (NOTE 2)
IQ Image	dB	-25		Image frequencies (NOTES 2, 3)
Carrier leakage	dBc	-25	0 dBm ≤ Output power	Carrier frequency (NOTES 4, 5)
		-20	-30 dBm ≤ Output power ≤ 0 dBm	
		-10	-40 dBm ≤ Output power < -30 dBm	
<p>NOTE 1: An in-band emissions combined limit is evaluated in each non-allocated tone. For each such tone, the minimum requirement is calculated as the higher of <math>P_{\text{tone}} - 30</math> dB and the power sum of all limit values (General, IQ Image or Carrier leakage) that apply. <math>P_{\text{tone}}</math> is defined in NOTE 9.</p> <p>NOTE 2: The measurement bandwidth is 1 tone and the limit is expressed as a ratio of measured power in one non-allocated tone to the measured average power per allocated tone, where the averaging is done across all allocated tones.</p> <p>NOTE 3: The applicable frequencies for this limit are those that are enclosed in the reflection of the allocated bandwidth, based on symmetry with respect to the centre carrier frequency, but excluding any allocated tones.</p> <p>NOTE 4: The measurement bandwidth is 1 tone and the limit is expressed as a ratio of measured power in one non-allocated tone to the measured total power in all allocated tones.</p> <p>NOTE 5: The applicable frequencies for this limit are those that are enclosed in the tones containing the DC frequency if <math>N_{\text{tone}}</math> is odd, or in the two tones immediately adjacent to the DC frequency if <math>N_{\text{tone}}</math> is even, but excluding any allocated tone.</p> <p>NOTE 6: <math>L_{C\text{tone}}</math> is the Transmission Bandwidth (tones).</p> <p>NOTE 7: <math>N_{\text{tone}}</math> is the Transmission Bandwidth Configuration (tones).</p> <p>NOTE 8: <math>\Delta_{\text{tone}}</math> is the starting frequency offset between the allocated tone and the measured non-allocated tone. (e.g. <math>\Delta_{\text{tone}} = 1</math> or <math>\Delta_{\text{tone}} = -1</math> for the first adjacent tone outside of the allocated bandwidth).</p> <p>NOTE 9: <math>P_{\text{tone}}</math> is the transmitted power per 3.75 kHz or 15 kHz in allocated tones, measured in dBm.</p>				

## 6.5.2G Transmit modulation quality for V2X Communication

The requirements in this clause apply to V2X sidelink transmissions.

When UE is configured for simultaneous E-UTRA V2X sidelink and E-UTRA uplink transmissions for inter-band E-UTRA V2X / E-UTRA bands specified in Table 5.5G-2, the requirements in subclause 6.5.2G apply for V2X sidelink transmission and the requirements in subclause 6.5.2 apply for the E-UTRA uplink transmission.

For V2X UE supporting Transmit Diversity, if the UE transmits on two antenna-connectors at the same time, the transmit modulation quality requirements for single carrier shall apply to each transmit antenna connector.

If V2X UE transmits on one-antenna connector at a time, the requirements specified for single carrier apply to the active antenna connector.

### 6.5.2G.1 Error Vector Magnitude

For V2X physical channels PSCCH, PSSCH and PSBCH, the Error Vector Magnitude requirements shall be as specified for PUSCH in subclause 6.5.2.1 for the corresponding modulation and transmission bandwidth.

For V2X sidelink physical channels PSCCH, PSSCH and PSBCH, the Error Vector Magnitude requirements shall be as specified separately for PSSCH and PSCCH for the corresponding modulation and transmission bandwidth. The measurement period for EVM of PSSCH and PSCCH is 15 subframes. The measurement period for reference signal EVM is 30 subframes. When V2X transmissions are shortened due to transmission gap of 1 symbol at the end of the subframe, the EVM measurement interval is reduced by one symbol, accordingly.

For PSBCH the duration over which EVM is averaged shall be 24 subframes.

For intra-band contiguous multi-carrier operation the EVM requirement shall apply for each component carrier.

### 6.5.2G.2 Carrier leakage

The requirements of subclause 6.5.2.2 shall apply for V2X transmissions.

For intra-band contiguous multi-carrier operation the carrier leakage requirement of subclause 6.5.2A.2 shall apply.

### 6.5.2G.3 In-band emissions

For V2X sidelink physical channels PSCCH, PSSCH and PSBCH, the In-band emissions requirements shall be as specified for PUSCH in subclause 6.5.2.3 for the corresponding modulation and transmission bandwidth. When V2X transmissions are shortened due to transmission gap of 1 symbol at the end of the subframe, the In-band emissions measurement interval is reduced by one symbol, accordingly.

For intra-band contiguous multi-carrier operation the in-band emission requirement of subclause 6.5.2A.3 shall apply.

### 6.5.2G.4 EVM equalizer spectrum flatness

The requirements of subclause 6.5.2.4 shall apply for V2X transmissions.

For intra-band contiguous multi-carrier operation the EVM equalizer spectrum flatness requirement of subclause 6.5.2.4 shall apply for each component carrier.

## 6.6 Output RF spectrum emissions

The output UE transmitter spectrum consists of the three components; the emission within the occupied bandwidth (channel bandwidth), the Out Of Band (OOB) emissions and the far out spurious emission domain.

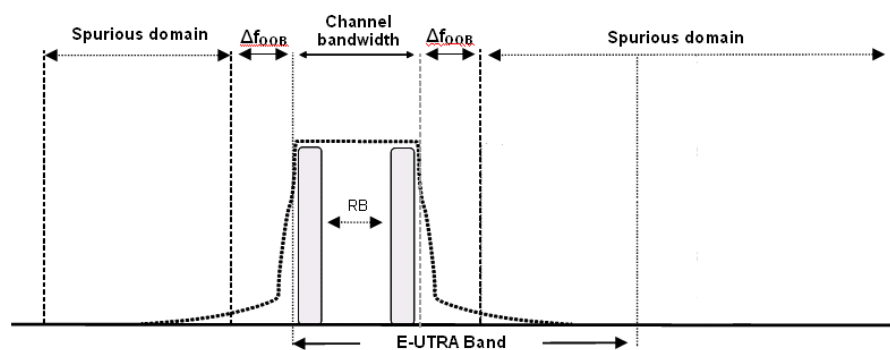

Figure 6.6-1: Transmitter RF spectrum

### 6.6.1 Occupied bandwidth

Occupied bandwidth is defined as the bandwidth containing 99 % of the total integrated mean power of the transmitted spectrum on the assigned channel. The occupied bandwidth for all transmission bandwidth configurations (Resources Blocks) shall be less than the channel bandwidth specified in Table 6.6.1-1

**Table 6.6.1-1: Occupied channel bandwidth**

	Occupied channel bandwidth / Channel bandwidth					
	1.4 MHz	3.0 MHz	5 MHz	10 MHz	15 MHz	20 MHz
<b>Channel bandwidth (MHz)</b>	1.4	3	5	10	15	20

### 6.6.1.1 Additional minimum requirement for E-UTRA (network signalled value "NS\_29")

For E-UTRA CA bands including one uplink LAA Scell in Band 46 with "NS\_29" indicated, the occupied bandwidth for all transmission bandwidth configurations (Resources Blocks) shall be less than or equal to 19 MHz and 19.7MHz for E-UTRA carriers of 20 MHz bandwidth assigned within 5150-5350 MHz and 5470-5725 MHz, respectively.

### 6.6.1A Occupied bandwidth for CA

For inter-band carrier aggregation with one component carrier per operating band and the uplink active in two E-UTRA bands the occupied bandwidth is defined per component carrier. Occupied bandwidth is the bandwidth containing 99 % of the total integrated mean power of the transmitted spectrum on assigned channel bandwidth on the component carrier. The occupied bandwidth shall be less than the channel bandwidth specified in Table 6.6.1-1.

For intra-band contiguous carrier aggregation the occupied bandwidth is a measure of the bandwidth containing 99 % of the total integrated power of the transmitted spectrum. The OBW shall be less than the aggregated channel bandwidth defined in subclause 5.6A.

For intra-band non-contiguous carrier aggregation sub-block occupied bandwidth is defined as the bandwidth containing 99 % of the total integrated mean power of the transmitted spectrum on the sub-block. In case the sub-block consist of one component carrier the occupied bandwidth of the sub-block shall be less than the channel bandwidth specified in Table 6.6.1-1.

For combinations of intra-band and inter-band carrier aggregation with three uplink component carriers (up to two contiguously aggregated carriers per band), the occupied bandwidth is the bandwidth containing 99 % of the total integrated mean power of the transmitted spectrum on each E-UTRA band. The OBW shall be less than the channel bandwidth as specified in Table 6.6.1-1 for the E-UTRA band supporting one component carrier. The OBW shall be less than the aggregated channel bandwidth as specified in subclause 5.6A for the E-UTRA band supporting two contiguous component carriers.

### 6.6.1B Occupied bandwidth for UL-MIMO

For UE supporting UL-MIMO, the requirements for occupied bandwidth is specified at each transmit antenna connector. The occupied bandwidth is defined as the bandwidth containing 99 % of the total integrated mean power of the transmitted spectrum on the assigned channel at each transmit antenna connector.

For UE with two transmit antenna connectors in closed-loop spatial multiplexing scheme, the occupied bandwidth at each transmitter antenna shall be less than the channel bandwidth specified in Table 6.6.1B-1. The requirements shall be met with the UL-MIMO configurations specified in Table 6.2.2B-2.

**Table 6.6.1B-1: Occupied channel bandwidth**

	Occupied channel bandwidth / Channel bandwidth					
	1.4 MHz	3.0 MHz	5 MHz	10 MHz	15 MHz	20 MHz
<b>Channel bandwidth (MHz)</b>	1.4	3	5	10	15	20

If UE is configured for transmission on single-antenna port, the requirements in subclause 6.6.1 apply.

## 6.6.1F Occupied bandwidth for category NB1 and NB2

The occupied bandwidth is defined as the bandwidth containing 99 % of the total integrated mean power of the transmitted spectrum on the assigned channel at the transmit antenna connector. Occupied bandwidth shall be less than the channel bandwidth of category NB1 and NB2 specified in Section 5.6F.

## 6.6.1G Occupied bandwidth for V2X Communication

When UE is configured for E-UTRA V2X sidelink transmissions non-concurrent with E-UTRA uplink transmissions for E-UTRA V2X operating bands specified in Table Table 5.5G-1, the requirements in subclause 6.6.1 apply for E-UTRA V2X sidelink transmission.

When UE is configured for simultaneous E-UTRA V2X sidelink and E-UTRA uplink transmissions for inter-band E-UTRA V2X / E-UTRA bands specified in Table 5.5G-2, the requirements in subclause 6.6.1 apply for V2X sidelink transmission and the E-UTRA uplink transmission.

For intra-band contiguous multi-carrier operation, the occupied bandwidth is a measure of the bandwidth containing 99 % of the total integrated power of the transmitted spectrum. The OBW shall be less than the aggregated channel bandwidth defined in subclause 5.6A.

For V2X UE supporting Transmit Diversity, if the UE transmits on two antenna connectors at the same time, the requirements for occupied bandwidth is specified at each transmit antenna connector and the occupied bandwidth at each transmitter antenna shall be less than the channel bandwidth specified for single carrier.

If V2X UE transmits on one antenna connector at a time, the requirements specified for single carrier shall apply to the active antenna connector.

## 6.6.2 Out of band emission

The Out of band emissions are unwanted emissions immediately outside the assigned channel bandwidth resulting from the modulation process and non-linearity in the transmitter but excluding spurious emissions. This out of band emission limit is specified in terms of a spectrum emission mask and an Adjacent Channel Leakage power Ratio.

### 6.6.2.1 Spectrum emission mask

The spectrum emission mask of the UE applies to frequencies ( $\Delta f_{\text{OoB}}$ ) starting from the  $\pm$  edge of the assigned E-UTRA channel bandwidth. For frequencies offset greater than  $\Delta f_{\text{OoB}}$  as specified in Table 6.6.2.1.1-1 the spurious requirements in subclause 6.6.3 are applicable.

#### 6.6.2.1.1 Minimum requirement

The power of any UE emission shall not exceed the levels specified in Table 6.6.2.1.1-1 for the specified channel bandwidth.

**Table 6.6.2.1.1-1: General E-UTRA spectrum emission mask**

Spectrum emission limit (dBm)/ Channel bandwidth							
$\Delta f_{\text{OoB}}$ (MHz)	1.4 MHz	3.0 MHz	5 MHz	10 MHz	15 MHz	20 MHz	Measurement bandwidth
$\pm 0-1$	-10	-13	-15	-18	-20	-21	30 kHz
$\pm 1-2.5$	-10	-10	-10	-10	-10	-10	1 MHz
$\pm 2.5-2.8$	-25	-10	-10	-10	-10	-10	1 MHz
$\pm 2.8-5$		-10	-10	-10	-10	-10	1 MHz
$\pm 5-6$		-25	-13	-13	-13	-13	1 MHz
$\pm 6-10$			-25	-13	-13	-13	1 MHz
$\pm 10-15$				-25	-13	-13	1 MHz
$\pm 15-20$					-25	-13	1 MHz
$\pm 20-25$						-25	1 MHz



NOTE: As a general rule, the resolution bandwidth of the measuring equipment should be equal to the measurement bandwidth. However, to improve measurement accuracy, sensitivity and efficiency, the resolution bandwidth may be smaller than the measurement bandwidth. When the resolution bandwidth is smaller than the measurement bandwidth, the result should be integrated over the measurement bandwidth in order to obtain the equivalent noise bandwidth of the measurement bandwidth.

### 6.6.2.1A Spectrum emission mask for CA

For inter-band carrier aggregation with one component carrier per operating band and the uplink active in two E-UTRA bands, the spectrum emission mask of the UE is defined per component carrier while both component carriers are active and the requirements are specified in subclauses 6.6.2.1 and 6.6.2.2. If for some frequency spectrum emission masks of component carriers overlap then spectrum emission mask allowing higher power spectral density applies for that frequency. If for some frequency a component carrier spectrum emission mask overlaps with the channel bandwidth of another component carrier, then the emission mask does not apply for that frequency.

For intra-band contiguous carrier aggregation the spectrum emission mask of the UE applies to frequencies ( $\Delta f_{\text{OoB}}$ ) starting from the  $\pm$  edge of the aggregated channel bandwidth (Table 5.6A-1) For intra-band contiguous carrier aggregation the bandwidth class B, C and D, the power of any UE emission shall not exceed the levels specified in Table 6.6.2.1A-0, Table 6.6.2.1A-1 and Table 6.6.2.1A-2 for the specified channel bandwidth.

**Table 6.6.2.1A-0: General E-UTRA CA spectrum emission mask for Bandwidth Class B**

$\Delta f_{\text{OoB}}$ (MHz)	25RB+25RB (9.8MHz)	25RB+50RB (14.95 MHz)	25RB+75RB (19.8MHz)	50RB+50RB (19.9 MHz)	Measurement bandwidth
$\pm 0-1$	-18	-20	-21	-21	30 kHz
$\pm 1-5$	-10	-10	-10	-10	1 MHz
$\pm 5-9.8$	-13	-13	-13	-13	1 MHz
$\pm 9.8-14.8$	-25	-13	-13	-13	1 MHz
$\pm 14.8-14.95$		-13	-13	-13	1 MHz
$\pm 14.95-19.80$		-25	-13	-13	1 MHz
$\pm 19.80-19.90$		-25	-25	-13	1 MHz
$\pm 19.90-19.95$		-25	-25	-25	1 MHz
$\pm 19.95-24.80$			-25	-25	1 MHz
$\pm 24.80-24.90$				-25	1 MHz

**Table 6.6.2.1A-1: General E-UTRA CA spectrum emission mask for Bandwidth Class C**

Spectrum emission limit [dBm]/BW <sub>Channel CA</sub>							
$\Delta f_{\text{OoB}}$ (MHz)	25RB+100RB (24.95MHz)	50RB+75RB (24.75 MHz)	50RB+100RB (29.9 MHz)	75RB+75RB (30 MHz)	75RB+100RB (34.85 MHz)	100RB+100RB (39.8 MHz)	Measurement bandwidth
$\pm 0-1$	-22	-22	-22.5	-22.5	-23.5	-24	30 kHz
$\pm 1-5$	-10	-10	-10	-10	-10	-10	1 MHz
$\pm 5-24.75$	-13	-13	-13	-13	-13	-13	1 MHz
$\pm 24.75-24.95$	-13	-25	-13	-13	-13	-13	1 MHz
$\pm 24.95-29.75$	-25	-25	-13	-13	-13	-13	1 MHz
$\pm 29.75-29.9$	-25		-13	-13	-13	-13	1 MHz
$\pm 29.9-29.95$	-25		-25	-13	-13	-13	1 MHz
$\pm 29.95-30$			-25	-13	-13	-13	1 MHz
$\pm 30-34.85$			-25	-25	-13	-13	1 MHz
$\pm 34.85-34.9$			-25	-25	-25	-13	1 MHz
$\pm 34.9-35$				-25	-25	-13	1 MHz
$\pm 35-39.8$					-25	-13	1 MHz
$\pm 39.8-39.85$					-25	-25	1 MHz
$\pm 39.85-44.8$						-25	1 MHz

Table 6.6.2.1A-2: General E-UTRA CA spectrum emission mask for Bandwidth Class D

$\Delta f_{\text{sub}}$ (MHz)	Spectrum emission limit [dBm]/BW <sub>Channel, CA</sub>						Measurement bandwidth
	50RB+75R B+100RB (44.6MHz)	75RB+75R B+75RB (45MHz)	50RB+100R B+100 RB (49.7MHz)	75RB+75RB +100RB (49.85MHz)	75RB+100R B+100RB (54.65MHz)	100RB+100 RB+100 RB (59.6MHz)	
± 0-1	-22	-22	-22.5	-22.5	-23.5	-24	30 kHz
± 1-5	-10	-10	-10	-10	-10	-10	1 MHz
± 5-44.6	-13	-13	-13	-13	-13	-13	1 MHz
± 44.6-45	-25	-13	-13	-13	-13	-13	1 MHz
± 45-49.6	-25	-25	-13	-13	-13	-13	1 MHz
± 49.6-49.7		-25	-13	-13	-13	-13	1 MHz
± 49.7-49.85		-25	-25	-13	-13	-13	1 MHz
± 49.85-50		-25	-25	-25	-13	-13	1 MHz
± 50-54.65			-25	-25	-13	-13	1 MHz
± 54.65-54.7			-25	-25	-25	-13	1 MHz
± 54.7-54.85				-25	-25	-13	1 MHz
± 54.85-59.6					-25	-13	1 MHz
± 59.6-59.65					-25	-25	1 MHz
± 59.65-64.6						-25	1 MHz

For intra-band non-contiguous carrier aggregation transmission the spectrum emission mask requirement is defined as a composite spectrum emissions mask. Composite spectrum emission mask applies to frequencies up to  $\pm \Delta f_{\text{sub}}$  starting from the edges of the sub-blocks. Composite spectrum emission mask is defined as follows

- Composite spectrum emission mask is a combination of individual sub-block spectrum emissions masks
- In case the sub-block consist of one component carrier the sub-block general spectrum emission mask is defined in subclause 6.6.2.1.1
- If for some frequency sub-block spectrum emission masks overlap then spectrum emission mask allowing higher power spectral density applies for that frequency
- If for some frequency a sub-block spectrum emission mask overlaps with the sub-block bandwidth of another sub-block, then the emission mask does not apply for that frequency.

For combinations of intra-band and inter-band carrier aggregation with three uplink component carriers (up to two contiguously aggregated carriers per band), the spectrum emission mask of the UE is defined per E-UTRA band while all component carriers are active. For the E-UTRA band supporting one component carrier the requirements in subclauses 6.6.2.1 and 6.6.2.2 apply. For the E-UTRA band supporting two contiguous component carriers the requirements specified in subclause 6.6.2.1A apply. If for some frequency spectrum emission masks of single component carrier and two contiguous component carriers overlap then spectrum emission mask allowing higher power spectral density applies for that frequency. If for some frequency spectrum emission masks of single component carrier or two contiguous component carriers overlap then the emission mask does not apply for that frequency.

### 6.6.2.2 Additional spectrum emission mask

This requirement is specified in terms of an "additional spectrum emission" requirement.

#### 6.6.2.2.1 Minimum requirement (network signalled value "NS\_03", "NS\_11", "NS\_20", and "NS\_21")

Additional spectrum emission requirements are signalled by the network to indicate that the UE shall meet an additional requirement for a specific deployment scenario as part of the cell handover/broadcast message.

When "NS\_03", "NS\_11", "NS\_20" or "NS\_21" is indicated in the cell, the power of any UE emission shall not exceed the levels specified in Table 6.6.2.2.1-1.

Table 6.6.2.2.1-1: Additional requirements

$\Delta f_{\text{OoB}}$ (MHz)	Spectrum emission limit (dBm)/ Channel bandwidth						Measurement bandwidth
	1.4 MHz	3.0 MHz	5 MHz	10 MHz	15 MHz	20 MHz	
$\pm 0-1$	-10	-13	-15	-18	-20	-21	30 kHz
$\pm 1-2.5$	-13	-13	-13	-13	-13	-13	1 MHz
$\pm 2.5-2.8$	-25	-13	-13	-13	-13	-13	1 MHz
$\pm 2.8-5$		-13	-13	-13	-13	-13	1 MHz
$\pm 5-6$		-25	-13	-13	-13	-13	1 MHz
$\pm 6-10$			-25	-13	-13	-13	1 MHz
$\pm 10-15$				-25	-13	-13	1 MHz
$\pm 15-20$					-25	-13	1 MHz
$\pm 20-25$						-25	1 MHz

NOTE: As a general rule, the resolution bandwidth of the measuring equipment should be equal to the measurement bandwidth. However, to improve measurement accuracy, sensitivity and efficiency, the resolution bandwidth may be smaller than the measurement bandwidth. When the resolution bandwidth is smaller than the measurement bandwidth, the result should be integrated over the measurement bandwidth in order to obtain the equivalent noise bandwidth of the measurement bandwidth.

#### 6.6.2.2.2 Minimum requirement (network signalled value "NS\_04")

Additional spectrum emission requirements are signalled by the network to indicate that the UE shall meet an additional requirement for a specific deployment scenario as part of the cell handover/broadcast message.

When "NS\_04" is indicated in the cell, the power of any UE emission shall not exceed the levels specified in Table 6.6.2.2.2-1.

Table 6.6.2.2.2-1: Additional requirements

$\Delta f_{\text{OoB}}$ (MHz)	Spectrum emission limit (dBm)/ Channel bandwidth					Measurement bandwidth
	5 MHz	10 MHz	15 MHz	20 MHz	Measurement bandwidth	
$\pm 0-1$	-15	-18	-20	-21		30 kHz
$\pm 1-2.5$	-10	-10	-10	-10		1 MHz
$\pm 2.5-2.8$	-10	-10	-10	-10		1 MHz
$\pm 2.8-5$	-10	-10	-10	-10		1 MHz
$\pm 5-6$	-13	-13	-13	-13		1 MHz
$\pm 6-9$	-25	-13	-13	-13		1 MHz
$\pm 9-10$	-25	-25	-13	-13		1 MHz
$\pm 10-13.5$		-25	-13	-13		1 MHz
$\pm 13.5-15$		-25	-25	-13		1 MHz
$\pm 15-18$			-25	-13		1 MHz
$\pm 18-20$			-25	-25		1 MHz
$\pm 20-25$				-25		1 MHz

NOTE: As a general rule, the resolution bandwidth of the measuring equipment should be equal to the measurement bandwidth. However, to improve measurement accuracy, sensitivity and efficiency, the resolution bandwidth may be smaller than the measurement bandwidth. When the resolution bandwidth is smaller than the measurement bandwidth, the result should be integrated over the measurement bandwidth in order to obtain the equivalent noise bandwidth of the measurement bandwidth.

#### 6.6.2.2.3 Minimum requirement (network signalled value "NS\_06" or "NS\_07")

Additional spectrum emission requirements are signalled by the network to indicate that the UE shall meet an additional requirement for a specific deployment scenario as part of the cell handover/broadcast message.

When "NS\_06" or "NS\_07" is indicated in the cell, the power of any UE emission shall not exceed the levels specified in Table 6.6.2.2.3-1.

Table 6.6.2.2.3-1: Additional requirements

$\Delta f_{\text{OoB}}$ (MHz)	Spectrum emission limit (dBm)/ Channel bandwidth				
	1.4 MHz	3.0 MHz	5 MHz	10 MHz	Measurement bandwidth
$\pm 0-0.1$	-13	-13	-15	-18	30 kHz
$\pm 0.1-1$	-13	-13	-13	-13	100 kHz
$\pm 1-2.5$	-13	-13	-13	-13	1 MHz
$\pm 2.5-2.8$	-25	-13	-13	-13	1 MHz
$\pm 2.8-5$		-13	-13	-13	1 MHz
$\pm 5-6$		-25	-13	-13	1 MHz
$\pm 6-10$			-25	-13	1 MHz
$\pm 10-15$				-25	1 MHz

NOTE: As a general rule, the resolution bandwidth of the measuring equipment should be equal to the measurement bandwidth. However, to improve measurement accuracy, sensitivity and efficiency, the resolution bandwidth may be smaller than the measurement bandwidth. When the resolution bandwidth is smaller than the measurement bandwidth, the result should be integrated over the measurement bandwidth in order to obtain the equivalent noise bandwidth of the measurement bandwidth.

#### 6.6.2.2.4 Minimum requirement (network signalled value "NS\_33" or "NS\_34")

The additional spectrum mask in Table 6.6.2.2.4-1 applies for E-UTRA V2X UE within 5 855 MHz to 5 950 MHz according to ETSI EN 302 571. Additional spectrum emission requirements are signalled by the network to indicate that the UE shall meet an additional requirement for a specific deployment scenario as part of the cell handover/broadcast message.

When "NS\_33" or "NS\_34" is indicated in the cell, the power of any V2X UE emission shall not exceed the levels specified in Table 6.6.2.2.4-1.

Table 6.6.2.2.4-1: Additional requirements for 10MHz channel bandwidth

$\Delta f_{\text{OoB}}$ (MHz)	Spectrum emission limit (dBm EIRP)/ Channel bandwidth	
	10 MHz	Measurement bandwidth
$\pm 0-0.5$	$[-13 - 12 \left( \frac{ \Delta f_{\text{OoB}} }{\text{MHz}} \right)]$	100 kHz
$\pm 0.5-5$	$[-19 - \frac{16}{9} \left( \frac{ \Delta f_{\text{OoB}} }{\text{MHz}} - 0.5 \right)]$	100 kHz
$\pm 5-10$	$[-27 - 2 \left( \frac{ \Delta f_{\text{OoB}} }{\text{MHz}} - 5.0 \right)]$	100 kHz

NOTE 1: As a general rule, the resolution bandwidth of the measuring equipment should be equal to the measurement bandwidth. However, to improve measurement accuracy, sensitivity and efficiency, the resolution bandwidth may be smaller than the measurement bandwidth. When the resolution bandwidth is smaller than the measurement bandwidth, the result should be integrated over the measurement bandwidth in order to obtain the equivalent noise bandwidth of the measurement bandwidth.

NOTE 2: Additional SEM for V2X overrides any other requirements in frequency range 5855-5950MHz.

NOTE 3: The EIRP requirement is converted to conducted requirement depend on the supported post antenna connector gain  $G_{\text{post connector}}$  declared by the UE following the principle described in annex I.

#### 6.6.2.2.5 Minimum requirement (network signalled value "NS\_27" and "NS\_43")

Additional spectrum emission requirements are signalled by the network to indicate that the UE shall meet an additional requirement for a specific deployment scenario as part of the cell handover/broadcast message.

When "NS\_27" or "NS\_43" is indicated in the cell, the power of any UE emission shall not exceed the levels specified in Table 6.6.2.2.5-1.

Table 6.6.2.2.5-1: Additional requirements

$\Delta f_{\text{OoB}}$ (MHz)	Spectrum emission limit (dBm)/ Channel bandwidth				
	5 MHz	10 MHz	15 MHz	20 MHz	Measurement bandwidth
$\pm 0-1$	-13	-13	-13	-13	Note 1
$\pm 1-10$	-13	-13	-13	-13	1 MHz
$\pm 10-15$		-25	-25	-25	1 MHz
$\pm 15-20$			-25	-25	1 MHz
$\pm 20-25$				-25	1 MHz

Note 1: The measurement bandwidth is 1% of the applicable E-UTRA channel bandwidth.

## 6.6.2.2.6 Minimum requirement (network signalled value "NS\_28")

When "NS\_28" is indicated in the cell, the power of any UE emission shall not exceed the levels specified in Table 6.6.2.2.6-1 for E-UTRA channels assigned within the frequency ranges 5150-5350 and 5470-5725 MHz.

Table 6.6.2.2.6-1: Additional requirements

Frequency offset of measurement filter -3dB point, $\Delta f$	Frequency offset of measurement filter centre frequency, $f_{\text{offset}}$	Minimum requirement [dBm]	Measurement bandwidth
$0 \text{ MHz} \leq \Delta f < 0.5 \text{ MHz}$	$0.5 \text{ MHz} \leq f_{\text{offset}} < 1 \text{ MHz}$	$10 - 20(f_{\text{offset}}/\text{MHz}) \text{ dB}$	1 MHz
$0.5 \text{ MHz} \leq \Delta f < 9.5 \text{ MHz}$	$1 \text{ MHz} \leq f_{\text{offset}} < 10 \text{ MHz}$	$-10 - 8/9(f_{\text{offset}}/\text{MHz} - 1) \text{ dB}$	1 MHz
$9.5 \text{ MHz} \leq \Delta f < 19.5 \text{ MHz}$	$10 \text{ MHz} \leq f_{\text{offset}} < 20 \text{ MHz}$	$-28 - 1.2(f_{\text{offset}}/\text{MHz} - 10) \text{ dB}$	1 MHz
$19.5 \text{ MHz} \leq \Delta f$	$20 \text{ MHz} \leq f_{\text{offset}}$	-30	1 MHz

NOTE 1: The measurement filter -3dB point is that closest to the channel edge.  
NOTE 2: The requirement applies when the offset of the measurement filter centre frequency is such that both -3 dB points of the measurement filter are confined within any of the two frequency ranges 5150-5250 MHz and 5470-5725 MHz.

NOTE: As a general rule, the resolution bandwidth of the measuring equipment should be equal to the measurement bandwidth. However, to improve measurement accuracy, sensitivity and efficiency, the resolution bandwidth may be smaller than the measurement bandwidth. When the resolution bandwidth is smaller than the measurement bandwidth, the result should be integrated over the measurement bandwidth in order to obtain the equivalent noise bandwidth of the measurement bandwidth.

## 6.6.2.2.7 Minimum requirement (network signalled value "NS\_35")

Additional spectrum emission requirements are signalled by the network to indicate that the UE shall meet an additional requirement for a specific deployment scenario as part of the cell handover/broadcast message.

When "NS\_35" is indicated in the cell, the power of any UE emission shall not exceed the levels specified in Table 6.6.2.2.7-1.

Table 6.6.2.2.7-1: Additional requirements

$\Delta f_{\text{OoB}}$ (MHz)	5 MHz	10 MHz	15 MHz	20 MHz	Measurement bandwidth (unless otherwise stated)
$\pm 0-0.1$	-15	-18	-20	-21	30 kHz
$\pm 0.1-6$	-13	-13	-13	-13	100 kHz
$\pm 6-10$	-25 <sup>1</sup>	-13	-13	-13	100 kHz
$\pm 10-15$		-25 <sup>1</sup>	-13	-13	100 kHz
$\pm 15-20$			-25 <sup>1</sup>	-13	100 kHz
$\pm 20-25$				-25	1 MHz

Note 1: The measurement bandwidth shall be 1 MHz

NOTE: As a general rule, the resolution bandwidth of the measuring equipment should be equal to the measurement bandwidth. However, to improve measurement accuracy, sensitivity and efficiency, the resolution bandwidth may be smaller than the measurement bandwidth. When the resolution bandwidth is smaller than the measurement bandwidth, the result should be integrated over the measurement bandwidth in order to obtain the equivalent noise bandwidth of the measurement bandwidth.

### 6.6.2.2A Additional Spectrum Emission Mask for CA

This requirement is specified in terms of an "additional spectrum emission" requirement.

#### 6.6.2.2A.1 Minimum requirement (network signalled value "CA\_NS\_04")

Additional spectrum emission requirements are signalled by the network to indicate that the UE shall meet an additional requirement for a specific deployment scenario as part of the cell handover/broadcast message.

When "CA\_NS\_04" is indicated in the cell, the power of any UE emission shall not exceed the levels specified in Table 6.6.2.2A.1-1.

**Table 6.6.2.2A.1-1: Additional requirements**

Spectrum emission limit [dBm]/BW <sub>Channel CA</sub>							
$\Delta f_{\text{foob}}$ (MHz)	50+75RB (24.75 MHz)	25+100RB (24.95 MHz)	50+100RB (29.9 MHz)	75+75RB (30 MHz)	75+100RB (34.85 MHz)	100+100RB (39.8 MHz)	Measurement bandwidth
± 0-1	-22	-22	-22.5	-23	-23.5	-24	30 kHz
± 1-5	-10	-10	-10	-10	-10	-10	1 MHz
± 5-22.95	-13	-13	-13	-13	-13	-13	1 MHz
± 22.95-23.25	-13	-25	-13	-13	-13	-13	1 MHz
± 23.25-27.9	-25	-25	-13	-13	-13	-13	1 MHz
± 27.9-28.5	-25	-25	-25	-13	-13	-13	1 MHz
± 28.5-29.75	-25	-25	-25	-25	-13	-13	1 MHz
± 29.75-29.95		-25	-25	-25	-13	-13	1 MHz
± 29.95-32.85			-25	-25	-13	-13	1 MHz
± 32.85-34.9			-25	-25	-25	-13	1 MHz
± 34.9-35				-25	-25	-13	1 MHz
± 35-37.8					-25	-13	1 MHz
± 37.8-39.85					-25	-25	1 MHz
± 39.85-44.8						-25	1 MHz

NOTE: As a general rule, the resolution bandwidth of the measuring equipment should be equal to the measurement bandwidth. However, to improve measurement accuracy, sensitivity and efficiency, the resolution bandwidth may be smaller than the measurement bandwidth. When the resolution bandwidth is smaller than the measurement bandwidth, the result should be integrated over the measurement bandwidth in order to obtain the equivalent noise bandwidth of the measurement bandwidth.

#### 6.6.2.2A.2 Minimum requirement CA\_66B (network signalled value "CA\_NS\_09")

Additional spectrum emission requirements are signalled by the network to indicate that the UE shall meet an additional requirement for a specific deployment scenario as part of the cell handover/broadcast message.

When "CA\_NS\_09" is indicated in the cell, the power of any UE emission shall not exceed the levels specified in Table 6.6.2.2A.2-1.

Table 6.6.2.2A.2-1: Additional requirements

$\Delta f_{\text{OoB}}$ (MHz)	25RB+25RB (9.8MHz)	25RB+50RB (14.95 MHz)	25RB+75RB (19.8MHz)	50RB+50RB (19.9 MHz)	Measurement bandwidth
± 0-1	-18	-20	-21	-21	30 kHz
± 1-5	-13	-13	-13	-13	1 MHz
± 5-9.8	-13	-13	-13	-13	1 MHz
± 9.8-14.8	-25	-13	-13	-13	1 MHz
± 14.8-14.95		-13	-13	-13	1 MHz
± 14.95-19.80		-25	-13	-13	1 MHz
± 19.80-19.90		-25	-25	-13	1 MHz
± 19.90-19.95		-25	-25	-25	1 MHz
± 19.95-24.80			-25	-25	1 MHz
± 24.80-24.90				-25	1 MHz

NOTE: As a general rule, the resolution bandwidth of the measuring equipment should be equal to the measurement bandwidth. However, to improve measurement accuracy, sensitivity and efficiency, the resolution bandwidth may be smaller than the measurement bandwidth. When the resolution bandwidth is smaller than the measurement bandwidth, the result should be integrated over the measurement bandwidth in order to obtain the equivalent noise bandwidth of the measurement bandwidth.

### 6.6.2.2A.3 Minimum requirement CA\_66C (network signalled value "CA\_NS\_09")

Additional spectrum emission requirements are signalled by the network to indicate that the UE shall meet an additional requirement for a specific deployment scenario as part of the cell handover/broadcast message.

When "CA\_NS\_09" is indicated in the cell, the power of any UE emission shall not exceed the levels specified in Table 6.6.2.2A.3-1.

Table 6.6.2.2A.3-1: Additional requirements

$\Delta f_{\text{OoB}}$ (MHz)	Spectrum emission limit [dBm]/BW <sub>Channel_CA</sub>						Measurement bandwidth
	25RB+100RB (24.95MHz)	50RB+75RB (24.75 MHz)	50RB+100RB (29.9 MHz)	75RB+75RB (30 MHz)	75RB+100RB (34.85 MHz)	100RB+100RB (39.8 MHz)	
± 0-1	-22	-22	-22.5	-22.5	-23.5	-24	30 kHz
± 1-5	-13	-13	-13	-13	-13	-13	1 MHz
± 5-24.75	-13	-13	-13	-13	-13	-13	1 MHz
± 24.75-24.95	-13	-25	-13	-13	-13	-13	1 MHz
± 24.95-29.75	-25	-25	-13	-13	-13	-13	1 MHz
± 29.75-29.9	-25		-13	-13	-13	-13	1 MHz
± 29.9-29.95	-25		-25	-13	-13	-13	1 MHz
± 29.95-30			-25	-13	-13	-13	1 MHz
± 30-34.85			-25	-25	-13	-13	1 MHz
± 34.85-34.9			-25	-25	-25	-13	1 MHz
± 34.9-35				-25	-25	-13	1 MHz
± 35-39.8					-25	-13	1 MHz
± 39.8-39.85					-25	-25	1 MHz
± 39.85-44.8						-25	1 MHz

NOTE: As a general rule, the resolution bandwidth of the measuring equipment should be equal to the measurement bandwidth. However, to improve measurement accuracy, sensitivity and efficiency, the resolution bandwidth may be smaller than the measurement bandwidth. When the resolution bandwidth is smaller than the measurement bandwidth, the result should be integrated over the measurement bandwidth in order to obtain the equivalent noise bandwidth of the measurement bandwidth.

### 6.6.2.2A.4 Minimum requirement CA\_48B and CA\_48C (network signalled value "CA\_NS\_10")

Additional spectrum emission requirements are signalled by the network to indicate that the UE shall meet an additional requirement for a specific deployment scenario as part of the cell handover/broadcast message.

When "CA\_NS\_10" is indicated in the cell, the power of any UE emission shall not exceed the levels specified in Table 6.6.2.2A.4-1.

**Table 6.6.2.2A.4-1: Additional requirements for "CA\_NS\_10"**

$\Delta f_{\text{OoB}}$ MHz	Spectrum emission limit (dBm) / measurement bandwidth for each channel bandwidth					Measurement bandwidth
	25+100RB (24.95MHz)	50+50RB (19.9 MHz)	50+100RB (29.9 MHz)	75+100RB (34.85 MHz)	100+100RB (39.8 MHz)	
$\pm 0 - 1$	-13					1 % channel bandwidth
$\pm 1 - X$	-13					1 MHz
$< -X$ or $> X$ when 3540 MHz $< \Delta f_{\text{OoB}} < 3710$ MHz	-25					

NOTE: X is aggregated channel bandwidth as defined in clause 5.6A

NOTE: As a general rule, the resolution bandwidth of the measuring equipment should be equal to the measurement bandwidth. However, to improve measurement accuracy, sensitivity and efficiency, the resolution bandwidth may be smaller than the measurement bandwidth. When the resolution bandwidth is smaller than the measurement bandwidth, the result should be integrated over the measurement bandwidth in order to obtain the equivalent noise bandwidth of the measurement bandwidth.

### 6.6.2.3 Adjacent Channel Leakage Ratio

Adjacent Channel Leakage power Ratio (ACLR) is the ratio of the filtered mean power centred on the assigned channel frequency to the filtered mean power centred on an adjacent channel frequency. ACLR requirements for one E-UTRA carrier are specified for two scenarios for an adjacent E-UTRA and /or UTRA channel as shown in Figure 6.6.2.3-1.

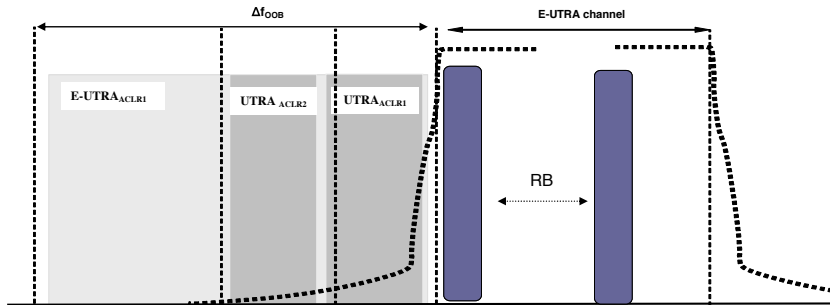

**Figure 6.6.2.3-1: Adjacent Channel Leakage requirements for one E-UTRA carrier**

#### 6.6.2.3.1 Minimum requirement E-UTRA

E-UTRA Adjacent Channel Leakage power Ratio (E-UTRA<sub>ACLR</sub>) is the ratio of the filtered mean power centred on the assigned channel frequency to the filtered mean power centred on an adjacent channel frequency at nominal channel spacing. The assigned E-UTRA channel power and adjacent E-UTRA channel power are measured with rectangular filters with measurement bandwidths specified in Table 6.6.2.3.1-1, Table 6.6.2.3.1-2, and Table 6.6.2.3.1-3. If the measured adjacent channel power is greater than -50dBm then the E-UTRA<sub>ACLR</sub> shall be higher than the value specified in Table 6.6.2.3.1-1, Table 6.6.2.3.1-2, and Table 6.6.2.3.1-3.

For a power class 2 capable UE operating on Band 41, when an IE *P-max* as defined in [7] of 23 dBm or lower is indicated in the cell or if the uplink/downlink configuration is 0 or 6, the requirements for power class 2 are not applicable, and the corresponding requirements for a power class 3 UE shall apply.

For each supported frequency band other than Band 41, the UE shall:



- if the UE supports a different power class than the default UE power class for the band and the supported power class enables the higher maximum output power than that of the default power class:
  - if the band is a TDD band whose frame configuration is 0 or 6; or
  - if the IE *P-Max* as defined in TS 36.331 [7] is not provided; or
  - if the IE *P-Max* as defined in TS 36.331 [7] is provided and set to the maximum output power of the default power class or lower;
    - meet all requirements for the default power class of the operating band in which the UE is operating and set its configured transmitted power as specified in sub-clause 6.2.5;
- else (i.e the IE *P-Max* as defined in TS 36.331 [7] is provided and set to the higher value than the maximum output power of the default power class):
  - meet all requirements for the supported power class and set its configured transmitted power class as specified in sub-clause 6.2.5.

**Table 6.6.2.3.1-1: General requirements for E-UTRA<sub>ACLR</sub>**

	Channel bandwidth / E-UTRA <sub>ACLR1</sub> / Measurement bandwidth					
	1.4 MHz	3.0 MHz	5 MHz	10 MHz	15 MHz	20 MHz
E-UTRA <sub>ACLR1</sub>	30 dB	30 dB	30 dB	30 dB	30 dB	30 dB
E-UTRA channel Measurement bandwidth	1.08 MHz	2.7 MHz	4.5 MHz	9.0 MHz	13.5 MHz	18 MHz
Adjacent channel centre frequency offset [MHz]	+1.4 / -1.4	+3.0 / -3.0	+5 / -5	+10 / -10	+15 / -15	+20 / -20

**Table 6.6.2.3.1-2: Additional E-UTRA<sub>ACLR</sub> requirements for Power Class 1**

	Channel bandwidth / E-UTRA <sub>ACLR1</sub> / Measurement bandwidth					
	1.4 MHz	3.0 MHz	5 MHz	10 MHz	15 MHz	20 MHz
E-UTRA <sub>ACLR1</sub>	37 dB	37 dB	37 dB	37 dB	37 dB	37 dB
E-UTRA channel Measurement bandwidth	1.08 MHz	2.7 MHz	4.5 MHz	9.0 MHz	13.5 MHz	18 MHz
Adjacent channel centre frequency offset [MHz]	+1.4 / -1.4	+3.0 / -3.0	+5 / -5	+10 / -10	+15 / -15	+20 / -20

NOTE 1: E-UTRA<sub>ACLR1</sub> shall be applicable for >23dBm

**Table 6.6.2.3.1-3: Additional E-UTRA<sub>ACLR</sub> requirements for Power Class 2**

	Channel bandwidth / E-UTRA <sub>ACLR1</sub> / Measurement bandwidth					
	1.4 MHz	3.0 MHz	5 MHz	10 MHz	15 MHz	20 MHz
E-UTRA <sub>ACLR1</sub>	N/A	N/A	31 dB	31 dB	31 dB	31 dB
E-UTRA channel Measurement bandwidth	N/A	N/A	4.5 MHz	9.0 MHz	13.5 MHz	18 MHz
Adjacent channel centre frequency offset [MHz]	N/A	N/A	+5 / -5	+10 / -10	+15 / -15	+20 / -20

#### 6.6.2.3.1a Additional minimum requirement for E-UTRA (network signalled value "NS\_29")

When "NS\_29" is indicated in the cell, the UE emission shall meet the additional requirements specified in Table 6.6.2.3.1a-1 for E-UTRA channels assigned within the frequency ranges 5150-5350 MHz and 5470-5725 MHz. The

assigned E-UTRA channel power and alternative adjacent E-UTRA channel power are measured with rectangular filters with measurement bandwidths specified in Table 6.6.2.3.1a-1. If the measured alternative adjacent channel power is greater than  $-50\text{dBm}$  then the  $E\text{-UTRA}_{\text{ACLR}2}$  shall be higher than the value specified in Table 6.6.2.3.1a-1.

**Table 6.6.2.3.1a-1: Additional  $E\text{-UTRA}_{\text{ACLR}}$  requirement**

	Channel bandwidth / $E\text{-UTRA}_{\text{ACLR}2}$ / Measurement bandwidth
	20 MHz
$E\text{-UTRA}_{\text{ACLR}2}$	40 dBc
E-UTRA channel Measurement bandwidth	NOTE 1
Adjacent channel centre frequency offset [MHz]	+40 / -40
NOTE 1: 18 MHz for E-UTRA channels assigned within 5150-5350 MHz; 19 MHz for E-UTRA channels assigned within 5470-5725 MHz.	

6.6.2.3.1A Void

6.6.2.3.1Aa Void

### 6.6.2.3.2 Minimum requirements UTRA

UTRA Adjacent Channel Leakage power Ratio ( $UTRA_{\text{ACLR}}$ ) is the ratio of the filtered mean power centred on the assigned E-UTRA channel frequency to the filtered mean power centred on an adjacent(s) UTRA channel frequency.

UTRA Adjacent Channel Leakage power Ratio is specified for both the first UTRA adjacent channel ( $UTRA_{\text{ACLR}1}$ ) and the 2<sup>nd</sup> UTRA adjacent channel ( $UTRA_{\text{ACLR}2}$ ). The UTRA channel power is measured with a RRC bandwidth filter with roll-off factor  $\alpha = 0.22$ . The assigned E-UTRA channel power is measured with a rectangular filter with measurement bandwidth specified in Table 6.6.2.3.2-1. If the measured UTRA channel power is greater than  $-50\text{dBm}$  then the  $UTRA_{\text{ACLR}}$  shall be higher than the value specified in Table 6.6.2.3.2-1.

$UTRA_{\text{ACLR}}$  is not applicable to the power class 3 UE operating in Band 7, 12, 13, 17, 20, 24, 27, 30, 33, 35, 36, 37, 38, 40, 43, 44, 45, 47, 48, 50, 51, 52, 68, 70, 71, 85 and Scell operation in Band 46, 49.

$UTRA_{\text{ACLR}}$  is not applicable to the power class 2 UE operating in Band 38, 40, 41, 42 or 47 and Scell operation in Band 46.

$UTRA_{\text{ACLR}}$  is not applicable to the power class 1 UE operating in Band 3, 20, 28, 31 or 72.

Table 6.6.2.3.2-1: Requirements for UTRA<sub>ACLR1/2</sub>

	Channel bandwidth / UTRA <sub>ACLR1/2</sub> / Measurement bandwidth					
	1.4 MHz	3.0 MHz	5 MHz	10 MHz	15 MHz	20 MHz
UTRA <sub>ACLR1</sub>	33 dB	33 dB	33 dB	33 dB	33 dB	33 dB
Adjacent channel centre frequency offset [MHz]	$0.7+BW_{UTRA}/2$ / -0.7- $BW_{UTRA}/2$	$1.5+BW_{UTRA}/2$ / -1.5- $BW_{UTRA}/2$	$+2.5+BW_{UTRA}/2$ / -2.5- $BW_{UTRA}/2$	$+5+BW_{UTRA}/2$ / -5- $BW_{UTRA}/2$	$+7.5+BW_{UTRA}/2$ / -7.5- $BW_{UTRA}/2$	$+10+BW_{UTRA}/2$ / -10- $BW_{UTRA}/2$
UTRA <sub>ACLR2</sub>	-	-	36 dB	36 dB	36 dB	36 dB
Adjacent channel centre frequency offset [MHz]	-	-	$+2.5+3*BW_{UTRA}/2$ / -2.5- $3*BW_{UTRA}/2$	$+5+3*BW_{UTRA}/2$ / -5- $3*BW_{UTRA}/2$	$+7.5+3*BW_{UTRA}/2$ / -7.5- $3*BW_{UTRA}/2$	$+10+3*BW_{UTRA}/2$ / -10- $3*BW_{UTRA}/2$
E-UTRA channel Measurement bandwidth	1.08 MHz	2.7 MHz	4.5 MHz	9.0 MHz	13.5 MHz	18 MHz
UTRA 5MHz channel Measurement bandwidth (NOTE 1)	3.84 MHz	3.84 MHz	3.84 MHz	3.84 MHz	3.84 MHz	3.84 MHz
UTRA 1.6MHz channel measurement bandwidth (NOTE 2)	1.28 MHz	1.28 MHz	1.28 MHz	1.28MHz	1.28MHz	1.28MHz
NOTE 1: Applicable for E-UTRA FDD co-existence with UTRA FDD in paired spectrum.						
NOTE 2: Applicable for E-UTRA TDD co-existence with UTRA TDD in unpaired spectrum.						

#### 6.6.2.3.2A Minimum requirement UTRA for CA

For inter-band carrier aggregation with one component carrier per operating band and the uplink active in two E-UTRA bands, the UTRA Adjacent Channel Leakage power Ratio (UTRA<sub>ACLR</sub>) is the ratio of the filtered mean power centred on the assigned channel bandwidth on the component carrier to the filtered mean power centred on an adjacent channel frequency. The UTRA Adjacent Channel Leakage power Ratio is defined per carrier and the requirement is specified in subclause 6.6.2.3.2.

For intra-band contiguous carrier aggregation the UTRA Adjacent Channel Leakage power Ratio (UTRA<sub>ACLR</sub>) is the ratio of the filtered mean power centred on the aggregated channel bandwidth to the filtered mean power centred on an adjacent(s) UTRA channel frequency.

For intra-band non-contiguous carrier aggregation when all sub-blocks consist of one component carrier the UTRA Adjacent Channel Leakage power Ratio (UTRA<sub>ACLR</sub>) is the ratio of the sum of the filtered mean powers centered on the assigned sub-block frequencies to the filtered mean power centred on an adjacent(s) UTRA channel frequency.

UTRA<sub>ACLR1/2</sub> requirements are applicable for all sub-blocks and are specified in Table 6.6.2.3.2A-2. UTRA<sub>ACLR1</sub> is required to be met in the sub-block gap when the gap bandwidth  $W_{gap}$  is  $5\text{MHz} \leq W_{gap} < 15\text{MHz}$ . Both UTRA<sub>ACLR1</sub> and UTRA<sub>ACLR2</sub> are required to be met in the sub-block gap when the gap bandwidth  $W_{gap}$  is  $15\text{MHz} \leq W_{gap}$ .

For combinations of intra-band and inter-band carrier aggregation with three uplink component carriers (up to two contiguously aggregated carriers per band), the UTRA Adjacent Channel Leakage power Ratio (UTRA<sub>ACLR</sub>) is defined as follows. For the E-UTRA band supporting one component carrier, the UTRA Adjacent Channel Leakage power Ratio (UTRA<sub>ACLR</sub>) is the ratio of the filtered mean power centred on the assigned channel bandwidth of the component carrier to the filtered mean power centred on an adjacent(s) UTRA channel frequency and the requirements specified in subclause 6.6.2.3.2 apply. For the E-UTRA band supporting two contiguous component carriers the UTRA Adjacent Channel Leakage power Ratio (UTRA<sub>ACLR</sub>) is the ratio of the filtered mean power centred on the aggregated channel bandwidth to the filtered mean power centred on an adjacent(s) UTRA channel frequency and the requirements specified in subclause 6.6.2.3.2A apply.

UTRA Adjacent Channel Leakage power Ratio is specified for both the first UTRA adjacent channel (UTRA<sub>ACLR1</sub>) and the 2<sup>nd</sup> UTRA adjacent channel (UTRA<sub>ACLR2</sub>). The UTRA channel power is measured with a RRC bandwidth filter with roll-off factor  $\alpha = 0.22$ . The assigned aggregated channel bandwidth power is measured with a rectangular filter with measurement bandwidth specified in Table 6.6.2.3.2A-1 for intraband contiguous carrier aggregation or 6.6.2.3.2A-2 for intraband non-contiguous carrier aggregation. If the measured UTRA channel power is greater than  $-50$  dBm then the UTRA<sub>ACLR</sub> shall be higher than the value specified in Table 6.6.2.3.2A-1 for intraband contiguous carrier aggregation or 6.6.2.3.2A-2 for intraband non-contiguous carrier aggregation.

For carrier aggregation with one or two uplink component carriers, the UTRA<sub>ACLR</sub> requirements for the PC3 UE are not applicable to the uplink component carrier(s) assigned to one of the E-UTRA band in Band 7, 12, 13, 17, 20, 24, 27, 30, 33, 35, 36, 37, 38, 40, 43, 44, 45, 46, 47, 48, 49, 50, 51, 52, 68, 70, 71 or 85.

**Table 6.6.2.3.2A-1: Requirements for UTRA<sub>ACLR1/2</sub>**

	CA bandwidth class / UTRA <sub>ACLR1/2</sub> / measurement bandwidth
	CA bandwidth class B, C and D
UTRA <sub>ACLR1</sub>	33 dB
Adjacent channel centre frequency offset (in MHz)	$\frac{+ BW_{\text{Channel\_CA}}/2 + BW_{\text{UTRA}}/2}{- BW_{\text{Channel\_CA}}/2 - BW_{\text{UTRA}}/2}$
UTRA <sub>ACLR2</sub>	36 dB
Adjacent channel centre frequency offset (in MHz)	$\frac{+ BW_{\text{Channel\_CA}}/2 + 3 \cdot BW_{\text{UTRA}}/2}{- BW_{\text{Channel\_CA}}/2 - 3 \cdot BW_{\text{UTRA}}/2}$
CA E-UTRA channel Measurement bandwidth	$BW_{\text{Channel\_CA}} - 2 \cdot BW_{\text{GB}}$
UTRA 5MHz channel Measurement bandwidth (NOTE 1)	3.84 MHz
UTRA 1.6MHz channel measurement bandwidth (NOTE 2)	1.28 MHz
NOTE 1: Applicable for E-UTRA FDD co-existence with UTRA FDD in paired spectrum.	
NOTE 2: Applicable for E-UTRA TDD co-existence with UTRA TDD in unpaired spectrum.	

**Table 6.6.2.3.2A-2: Requirements for intraband non-contiguous CA UTRA<sub>ACLR1/2</sub>**

	UTRA <sub>ACLR1/2</sub> / measurement bandwidth
UTRA <sub>ACLR1</sub>	33 dB
Adjacent channel centre frequency offset (in MHz)	$\frac{+ F_{\text{edge,block,high}} + BW_{\text{UTRA}}/2}{- F_{\text{edge,block,low}} - BW_{\text{UTRA}}/2}$
UTRA <sub>ACLR2</sub>	36 dB
Adjacent channel centre frequency offset (in MHz)	$\frac{+ F_{\text{edge,block,high}} + 3 \cdot BW_{\text{UTRA}}/2}{- F_{\text{edge,block,low}} - 3 \cdot BW_{\text{UTRA}}/2}$
Sub-block measurement bandwidth	$BW_{\text{Channel,block}} - 2 \cdot BW_{\text{GB}}$
UTRA 5 MHz channel Measurement bandwidth (NOTE 1)	3.84 MHz
UTRA 1.6 MHz channel measurement bandwidth (NOTE 2)	1.28 MHz
NOTE 1: Applicable for E-UTRA FDD co-existence with UTRA FDD in paired spectrum.	
NOTE 2: Applicable for E-UTRA TDD co-existence with UTRA TDD in unpaired spectrum.	

### 6.6.2.3.3A Minimum requirements for CA E-UTRA

For intra-band contiguous carrier aggregation the carrier aggregation E-UTRA Adjacent Channel Leakage power Ratio (CA E-UTRA<sub>ACL</sub>R) is the ratio of the filtered mean power centred on the aggregated channel bandwidth to the filtered mean power centred on an adjacent aggregated channel bandwidth at nominal channel spacing. The assigned aggregated channel bandwidth power and adjacent aggregated channel bandwidth power are measured with rectangular filters with measurement bandwidths specified in Table 6.6.2.3.3A-1. If the measured adjacent channel power is greater than  $-50\text{dBm}$  then the E-UTRA<sub>ACL</sub>R shall be higher than the value specified in Table 6.6.2.3.3A-1 and Table 6.6.2.3.3A-1a.

**Table 6.6.2.3.3A-1: General requirements for CA E-UTRA<sub>ACL</sub>R**

	CA bandwidth class / CA E-UTRA <sub>ACL</sub> R / Measurement bandwidth
	CA bandwidth class B, C and D
CA E-UTRA <sub>ACL</sub> R	30 dB
CA E-UTRA channel Measurement bandwidth	$BW_{\text{Channel\_CA}} - 2 * BW_{\text{GB}}$
Adjacent channel centre frequency offset (in MHz)	$+ BW_{\text{Channel\_CA}}$ / $- BW_{\text{Channel\_CA}}$

**Table 6.6.2.3.3A-1a: Additional requirements for CA E-UTRA<sub>ACL</sub>R for UL CA\_41C Power Class 2**

	CA bandwidth class / CA E-UTRA <sub>ACL</sub> R / Measurement bandwidth
	CA bandwidth class C
CA E-UTRA <sub>ACL</sub> R	31 dB
CA E-UTRA channel Measurement bandwidth	$BW_{\text{Channel\_CA}} - 2 * BW_{\text{GB}}$
Adjacent channel centre frequency offset (in MHz)	$+ BW_{\text{Channel\_CA}}$ / $- BW_{\text{Channel\_CA}}$

For inter-band carrier aggregation with one component carrier per operating band and the uplink active in two E-UTRA bands, E-UTRA Adjacent Channel Leakage power Ratio (E-UTRA<sub>ACL</sub>R) is the ratio of the filtered mean power centred on the assigned channel bandwidth on a component carrier to the filtered mean power centred on an adjacent channel frequency. The E-UTRA Adjacent Channel Leakage power Ratio is defined per carrier and the requirement is specified in subclause 6.6.2.3.1.

For intra-band non-contiguous carrier aggregation when all sub-blocks consist of one component carrier the E-UTRA Adjacent Channel Leakage power Ratio (E-UTRA<sub>ACL</sub>R) is the ratio of the sum of the filtered mean powers centred on the assigned sub-block frequencies to the filtered mean power centred on an adjacent channel frequency at nominal channel spacing. In case the sub-block gap bandwidth  $W_{\text{gap}}$  is smaller than of the sub-block bandwidth then for that sub-block no E-UTRA<sub>ACL</sub>R requirement is set for the gap. In case the sub-block gap bandwidth  $W_{\text{gap}}$  is smaller than either of the sub-block bandwidths then no E-UTRA<sub>ACL</sub>R requirement is set for the gap. The assigned E-UTRA sub-block power and adjacent E-UTRA channel power are measured with rectangular filters with measurement bandwidths specified in Table 6.6.2.3.3A-2. If the measured adjacent channel power is greater than  $-50\text{dBm}$  then the E-UTRA<sub>ACL</sub>R shall be higher than the value specified in Table 6.6.2.3.3A-2.

**Table 6.6.2.3.3A-2: General requirements for non-contiguous intraband CA E-UTRA<sub>ACL</sub>R**

	CC and adjacent channel bandwidth / E-UTRA <sub>ACL</sub> R / Measurement bandwidth					
	1.4 MHz	3 MHz	5 MHz	10 MHz	15 MHz	20 MHz
E-UTRA <sub>ACL</sub> R1	30 dB	30 dB	30 dB	30 dB	30 dB	30 dB
CC and adjacent channel measurement bandwidth [MHz]	1.08	2.7	4.5	9	13.5	18
Adjacent channel centre frequency offset [MHz]	+ 1.4 / - 1.4	+ 3 / - 3	+ 5 / - 5	+ 10 / - 10	+ 15 / - 15	+ 20 / - 20

For combinations of intra-band and inter-band carrier aggregation with three uplink component carriers (up to two contiguously aggregated carriers per band), the E-UTRA Adjacent Channel Leakage power Ratio (E-UTRA<sub>ACL</sub>R) is defined as follows. For the E-UTRA band supporting one component carrier, the E-UTRA Adjacent Channel Leakage power Ratio (UTRA<sub>ACL</sub>R) is the ratio of the filtered mean power centred on the assigned channel bandwidth of the component carrier to the filtered mean power centred on an adjacent channel frequency and the requirements in subclause 6.6.2.3.1 apply. For the E-UTRA band supporting two contiguous component carriers the E-UTRA Adjacent Channel Leakage power Ratio (E-UTRA<sub>ACL</sub>R) is the ratio of the filtered mean power centred on the aggregated channel bandwidth to the filtered mean power centred on an adjacent(s) aggregated channel bandwidth at nominal channel spacing and the requirements of CA E-UTRA<sub>ACL</sub>R specified in subclause 6.6.2.3.3A apply.

#### 6.6.2.4 Void

##### 6.6.2.4.1 Void

#### 6.6.2A Void

<reserved for future use>

#### 6.6.2B Out of band emission for UL-MIMO

For UE supporting UL-MIMO, the requirements for Out of band emissions resulting from the modulation process and non-linearity in the transmitters are specified at each transmit antenna connector.

For UEs with two transmit antenna connectors in closed-loop spatial multiplexing scheme, the requirements in subclause 6.6.2 apply to each transmit antenna connector. The requirements shall be met with the UL-MIMO configurations specified in Table 6.2.2B-2.

If UE is configured for transmission on single-antenna port, the requirements in subclause 6.6.3 apply.

#### 6.6.2C Void

<reserved for future use>

#### 6.6.2D Out of band emission for ProSe

When UE is configured for E-UTRA ProSe sidelink transmissions non-concurrent with E-UTRA uplink transmissions for E-UTRA ProSe operating bands specified in Table 5.5D-1, the requirements in subclause 6.6.2 apply.

When UE is configured for simultaneous E-UTRA ProSe sidelink and E-UTRA uplink transmissions for inter-band E-UTRA ProSe / E-UTRA bands specified in Table 5.5D-2, the requirements in subclause 6.6.2 apply per E-UTRA ProSe sidelink and E-UTRA uplink transmission as specified for the corresponding inter-band aggregation with uplink assigned to two bands.

## 6.6.2F Out of band emission for category NB1 and NB2

### 6.6.2F.1 Spectrum emission mask

The spectrum emission mask of the category NB1 and NB2 UE applies to frequencies ( $\Delta f_{\text{OOB}}$ ) starting from the  $\pm$  edge of the assigned category NB1 or NB2 channel bandwidth. For frequencies greater than ( $\Delta f_{\text{OOB}}$ ) as specified in Table 6.6.2F.1-1 the spurious requirements in subclause 6.6.3 are applicable.

The power of any category NB1 or NB2 UE emission shall not exceed the levels specified in Table 6.6.2F.1-1. The spectrum emission limit between each  $\Delta f_{\text{OOB}}$  is linearly interpolated.

**Table 6.6.2F.1-1: category NB1 and NB2 UE spectrum emission mask**

$\Delta f_{\text{OOB}}$ (kHz)	Emission limit (dBm)	Measurement bandwidth
$\pm 0$	26	30 kHz
$\pm 100$	-5	30 kHz
$\pm 150$	-8	30 kHz
$\pm 300$	-29	30 kHz
$\pm 500-1700$	-35	30 kHz

In addition to the spectrum emission mask requirement in Table 6.6.2F.1-1 a category NB1 or NB2 UE shall also meet the applicable E-UTRA spectrum emission mask requirement in sub-clause 6.6.2. E-UTRA spectrum emission requirement applies for frequencies that are Foffset away from edge of NB1 or NB2 channel edge as defined in Table 6.6.2F.1-2.

**Table 6.6.2F.1-2: Foffset for category NB1 and NB2 UE spectrum emission mask**

Channel BW (MHz)	Foffset [kHz]
1.4	165
3	190
5	200
10	225
15	240
20	245

Note: Foffset in Table 6.6.2F.1-2 is used to guarantee co-existence for guard-band operation.

### 6.6.2F.2 Additional Spectrum Emission Mask for Category NB1 and NB2

This requirement is specified in terms of an "additional spectrum emission" requirement.

#### 6.6.2F.2.1 Minimum requirement (network signalled value "NS\_02")

Additional spectrum emission requirements are signalled by the network to indicate that the UE shall meet an additional requirement for a specific deployment scenario as part of the cell broadcast message.

When "NS\_02" is indicated in the cell, the NB-IoT channel is deployed in the lower guard-band of a 10MHz E-UTRA channel and the separation between the two channel centres is equal to 4.695 MHz. The power of any UE emission shall not exceed the levels specified in Table 6.6.2.1.1-1 for the specified E-UTRA channel bandwidth and the levels specified in Table 6.6.2F.1-1 for the NB-IoT channel.

Note: UEs that meet the above emission requirement would automatically meet the E-UTRA additional spectrum emission masks as defined in 6.6.2.2 for the applicable operating bands.

#### 6.6.2F.2.2 Minimum requirement (network signalled value "NS\_03")

Additional spectrum emission requirements are signalled by the network to indicate that the UE shall meet an additional requirement for a specific deployment scenario as part of the cell broadcast message.

When "NS\_03" is indicated in the cell, the NB-IoT channel is deployed in the upper guard-band of a 10MHz E-UTRA channel and the separation between the two channel centres is equal to 4.695 MHz. The power of any UE emission shall not exceed the levels specified in Table 6.6.2.1.1-1 for the specified E-UTRA channel bandwidth and the levels specified in Table 6.6.2F.1-1 for the NB-IoT channel.

Note: UEs that meet the above emission requirement would automatically meet the E-UTRA additional spectrum emission masks as defined in 6.6.2.2 for the applicable operating bands.

### 6.6.2F.3 Adjacent Channel Leakage Ratio for category NB1 and NB2

Adjacent Channel Leakage power Ratio is the ratio of the filtered mean power centred on the assigned channel frequency to the filtered mean power centred on an adjacent channel frequency. The assigned category NB1 or NB2 channel power and adjacent channel power are measured with filters and measurement bandwidths specified in Table 6.6.2F.3-1. If the measured adjacent channel power is greater than  $-50\text{dBm}$  then the category NB1 or NB2 UE ACLR shall be higher than the value specified in Table 6.6.2F.3-1.  $\text{GSM}_{\text{ACLR}}$  requirement is intended for protection of GSM system.  $\text{UTRA}_{\text{ACLR}}$  requirement is intended for protection of UTRA and E-UTRA systems.

**Table 6.6.2F.3-1: category NB1 and NB2 UE ACLR requirements**

	$\text{GSM}_{\text{ACLR}}$	$\text{UTRA}_{\text{ACLR}}$
<b>ACLR</b>	20 dB	37 dB
<b>Adjacent channel center frequency offset from category NB1 or NB2 Channel edge</b>	$\pm 200$ kHz	$\pm 2.5$ MHz
<b>Adjacent channel measurement bandwidth</b>	180 kHz	3.84 MHz
<b>Measurement filter</b>	Rectangular	RRC-filter $\alpha=0.22$
<b>Category NB1 and NB2 channel measurement bandwidth</b>	180 kHz	180 kHz
<b>Category NB1 and NB2 channel Measurement filter</b>	Rectangular	Rectangular

### 6.6.2G Out of band emission for V2X Communication

When UE is configured for E-UTRA V2X sidelink transmissions non-concurrent with E-UTRA uplink transmissions for E-UTRA V2X operating bands specified in Table 5.5G-1, the requirements in subclause 6.6.2 apply except for the ACLR requirements for power class 2 V2X UE.

When UE is configured for simultaneous E-UTRA V2X sidelink and E-UTRA uplink transmissions for inter-band E-UTRA V2X / E-UTRA bands specified in Table 5.5G-2, the requirements in subclause 6.6.2 apply per V2X sidelink transmission and E-UTRA uplink transmission as specified for the corresponding inter-band concurrent operation with uplink assigned to two bands.

For intra-band contiguous multi-carrier operation, the general CA spectrum emission mask for CA Bandwidth Class B specified in subclause 6.6.2.1A shall apply for V2X Bandwidth Class B, the general CA spectrum emission mask for CA Bandwidth Class C specified in subclause 6.6.2.1A shall apply for V2X Bandwidth Class C and  $C_1$ .

For intra-band contiguous multi-carrier operation, the E-UTRA ACLR requirement for CA Bandwidth Class B specified in subclause 6.6.2.3.3A shall apply for V2X Bandwidth Class B, the general CA spectrum emission mask for CA Bandwidth Class C specified in subclause 6.6.2.3.3A shall apply for V2X Bandwidth Class C and  $C_1$ .



For power class 2 V2X UE, the assigned channel power and adjacent channel power are measured with rectangular filters with measurement bandwidths specified in Table 6.6.2G-1. If the measured adjacent channel power is greater than  $-50\text{dBm}$  then ACLR shall be higher than the value specified in Table 6.6.2G-1.

**Table 6.6.2G-1: ACLR requirements for power class 2 V2X Communication**

	Channel bandwidth / ACLR / Measurement bandwidth	
	10 MHz	20 MHz
ACLR	31 dB	31 dB
E-UTRA channel Measurement bandwidth	9.0 MHz	18 MHz
Adjacent channel centre frequency offset [MHz]	+10 / -10	+20 / -20

For V2X UE supporting Transmit Diversity, if the UE transmits on two antenna connectors at the same time, the requirements specified for single carrier apply to each transmit antenna connector.

If V2X UE transmits on one antenna connector at a time, the requirements specified for single carrier shall apply to the active antenna connector.

### 6.6.3 Spurious emissions

Spurious emissions are emissions which are caused by unwanted transmitter effects such as harmonics emission, parasitic emissions, intermodulation products and frequency conversion products, but exclude out of band emissions unless otherwise stated. The spurious emission limits are specified in terms of general requirements inline with SM.329 [2] and E-UTRA operating band requirement to address UE co-existence.

To improve measurement accuracy, sensitivity and efficiency, the resolution bandwidth may be smaller than the measurement bandwidth. When the resolution bandwidth is smaller than the measurement bandwidth, the result should be integrated over the measurement bandwidth in order to obtain the equivalent noise bandwidth of the measurement bandwidth.

#### 6.6.3.1 Minimum requirements

Unless otherwise stated, the spurious emission limits apply for the frequency ranges that are more than  $F_{\text{OOB}}$  (MHz) in Table 6.6.3.1-1 from the edge of the channel bandwidth. The spurious emission limits in Table 6.6.3.1-2 apply for all transmitter band configurations ( $N_{\text{RB}}$ ) and channel bandwidths.

NOTE: For measurement conditions at the edge of each frequency range, the lowest frequency of the measurement position in each frequency range should be set at the lowest boundary of the frequency range plus  $\text{MBW}/2$ . The highest frequency of the measurement position in each frequency range should be set at the highest boundary of the frequency range minus  $\text{MBW}/2$ . MBW denotes the measurement bandwidth defined for the protected band.

**Table 6.6.3.1-1: Boundary between E-UTRA out of band and spurious emission domain**

Channel bandwidth	1.4 MHz	3.0 MHz	5 MHz	10 MHz	15 MHz	20 MHz
OOB boundary $F_{\text{OOB}}$ (MHz)	2.8	6	10	15	20	25

**Table 6.6.3.1-2: Spurious emissions limits**

Frequency Range	Maximum Level	Measurement bandwidth	NOTE
$9 \text{ kHz} \leq f < 150 \text{ kHz}$	-36 dBm	1 kHz	
$150 \text{ kHz} \leq f < 30 \text{ MHz}$	-36 dBm	10 kHz	
$30 \text{ MHz} \leq f < 1000 \text{ MHz}$	-36 dBm	100 kHz	
$1 \text{ GHz} \leq f < 12.75 \text{ GHz}$	-30 dBm	1 MHz	
$12.75 \text{ GHz} \leq f < 5^{\text{th}}$ harmonic of the upper frequency edge of the UL operating band in GHz	-30 dBm	1 MHz	1
$12.75 \text{ GHz} < f < 26 \text{ GHz}$	-30 dBm	1 MHz	2
NOTE 1: Applies for Band 22, Band 42, Band 43 and Band 48.			
NOTE 2: Applies for Band 46 and Band 47.			

### 6.6.3.1A Minimum requirements for CA

This clause specifies the spurious emission requirements for carrier aggregation.

NOTE: For measurement conditions at the edge of each frequency range, the lowest frequency of the measurement position in each frequency range should be set at the lowest boundary of the frequency range plus MBW/2. The highest frequency of the measurement position in each frequency range should be set at the highest boundary of the frequency range minus MBW/2. MBW denotes the measurement bandwidth defined for the protected band.

For inter-band carrier aggregation with one component carrier per operating band and the uplink active in two E-UTRA bands, the spurious emission requirement Table 6.6.3.1-2 apply for the frequency ranges that are more than  $F_{\text{OOB}}$  as defined in Table 6.6.3.1-1 away from edges of the assigned channel bandwidth on a component carrier. If for some frequency a spurious emission requirement of individual component carrier overlaps with the spectrum emission mask or channel bandwidth of another component carrier then it does not apply.

NOTE: For inter-band carrier aggregation with uplink assigned to two E-UTRA bands the requirements in Table 6.6.3.1-2 could be verified by measuring spurious emissions at the specific frequencies where second and third order intermodulation products generated by the two transmitted carriers can occur; in that case, the requirements for remaining applicable frequencies in Table 6.6.3.1-2 would be considered to be verified by the measurements verifying the one uplink inter-band CA spurious emission requirement.

For intra-band contiguous carrier aggregation the spurious emission limits apply for the frequency ranges that are more than  $F_{\text{OOB}}$  (MHz) in Table 6.6.3.1A-1 from the edge of the aggregated channel bandwidth (Table 5.6A-1). For frequencies  $\Delta f_{\text{OOB}}$  greater than  $F_{\text{OOB}}$  as specified in Table 6.6.3.1A-1 the spurious emission requirements in Table 6.6.3.1-2 are applicable.

**Table 6.6.3.1A-1: Boundary between E-UTRA out of band and spurious emission domain for intra-band contiguous carrier aggregation**

CA Bandwidth Class	OOB boundary $F_{\text{OOB}}$ (MHz)
A	Table 6.6.3.1-1
B	$BW_{\text{Channel, CA}} + 5$
C	$BW_{\text{Channel, CA}} + 5$

For intra-band non-contiguous carrier aggregation transmission the spurious emission requirement is defined as a composite spurious emission requirement. Composite spurious emission requirement applies to frequency ranges that are more than  $F_{\text{OOB}}$  away from the edges of the sub-blocks. Composite spurious emission requirement is defined as follows

- a) Composite spurious emission requirement is a combination of individual sub-block spurious emission requirements

- b) In case the sub-block consist of one component carrier the sub-lock spurious emission requirement and  $F_{OOB}$  are defined in subclause 6.6.3.1
- c) If for some frequency an individual sub-block spurious emission requirement overlaps with the general spectrum emission mask or the sub-block bandwidth of another sub-block then it does not apply

For combinations of intra-band and inter-band carrier aggregation with three uplink component carriers (up to two contiguously aggregated carriers per band), the spurious emission requirement is defined as follows. For the E-UTRA band supporting one component carrier the requirements in Table 6.6.3.1-2 apply for frequency ranges that are more than  $FOOB$  (MHz) from the edges of assigned channel bandwidth as defined in Table 6.6.3.1-1. For the E-UTRA band supporting two contiguous component carriers the requirements in Table 6.6.3.1-2 apply for frequency ranges that are more than  $FOOB$  (MHz) from the edges of assigned aggregated channel bandwidth as defined in Table 6.6.3.1A-1. If for some frequency a spurious emission requirement of a single component carrier or two contiguous component carriers overlap with the spurious emission requirement or channel bandwidth of another component carrier or two contiguously aggregated carriers then it does not apply.

### 6.6.3.2 Spurious emission band UE co-existence

This clause specifies the requirements for the specified E-UTRA band, for coexistence with protected bands.

**NOTE:** For measurement conditions at the edge of each frequency range, the lowest frequency of the measurement position in each frequency range should be set at the lowest boundary of the frequency range plus  $MBW/2$ . The highest frequency of the measurement position in each frequency range should be set at the highest boundary of the frequency range minus  $MBW/2$ .  $MBW$  denotes the measurement bandwidth defined for the protected band.

**Table 6.6.3.2-1: Requirements**

E-UTRA Band	Spurious emission						
	Protected band	Frequency range (MHz)		Maximum Level (dBm)	MBW (MHz)	NOTE	
1	E-UTRA Band 1, 3, 5, 7, 8, 11, 18, 19, 20, 21, 22, 26, 27, 28, 31, 32, 38, 40, 41, 42, 43, 44, 45, 50, 51, 52, 65, 67, 68, 69, 72, 73, 74, 75, 76, 87, 88 NR Band n78, n79	F <sub>DL,low</sub>	-	F <sub>DL,high</sub>	-50	1	
	E-UTRA Band 34	F <sub>DL,low</sub>	-	F <sub>DL,high</sub>	-50	1	15
	NR Band n77	F <sub>DL,low</sub>	-	F <sub>DL,high</sub>	-50	1	2
	Frequency range	1880	-	1895	-40	1	15, 27
	Frequency range	1895	-	1915	-15.5	5	15, 26, 27
	Frequency range	1915	-	1920	+1.6	5	15, 26, 27, 44
2	E-UTRA Band 4, 5, 12, 13, 14, 17, 24, 26, 27, 28, 29, 30, 41, 42, 48, 50, 51, 53, 66, 70, 71, 74, 85	F <sub>DL,low</sub>	-	F <sub>DL,high</sub>	-50	1	
	E-UTRA Band 2, 25, NR Band n77	F <sub>DL,low</sub>	-	F <sub>DL,high</sub>	-50	1	15
	E-UTRA Band 43	F <sub>DL,low</sub>	-	F <sub>DL,high</sub>	-50	1	2
3	E-UTRA Band 1, 5, 7, 8, 11, 18, 19, 20, 21, 26, 27, 28, 31, 32, 33, 34, 38, 39, 40, 41, 43, 44, 45, 50, 51, 65, 67, 68, 69, 72, 73, 74, 75, 76, 87, 88 NR Band n79	F <sub>DL,low</sub>	-	F <sub>DL,high</sub>	-50	1	
	E-UTRA Band 3	F <sub>DL,low</sub>	-	F <sub>DL,high</sub>	-50	1	15
	E-UTRA Band 22, 42, 52 NR Band n77, n78	F <sub>DL,low</sub>	-	F <sub>DL,high</sub>	-50	1	2
	Frequency range	1884.5	-	1915.7	-41	0.3	
	Frequency range	1884.5	-	1915.7	-41	0.3	8, 39
4	E-UTRA Band 2, 4, 5, 7, 12, 13, 14, 17, 24, 25, 26, 27, 28, 29, 30, 41, 43, 48, 50, 51, 53, 66, 70, 71, 74, 85	F <sub>DL,low</sub>	-	F <sub>DL,high</sub>	-50	1	
	E-UTRA Band 42, NR Band n77	F <sub>DL,low</sub>	-	F <sub>DL,high</sub>	-50	1	2
5	E-UTRA Band 1, 2, 3, 4, 5, 7, 8, 12, 13, 14, 17, 24, 25, 28, 29, 30, 31, 34, 38, 40, 42, 43, 45, 48, 50, 51, 53, 65, 66, 70, 71, 73, 74, 85	F <sub>DL,low</sub>	-	F <sub>DL,high</sub>	-50	1	
	E-UTRA Band 26	859	-	869	-27	1	
	E-UTRA Band 41, 52 NR Band n77, n78, n79	F <sub>DL,low</sub>	-	F <sub>DL,high</sub>	-50	1	2
	E-UTRA Band 18, 19	F <sub>DL,low</sub>	-	F <sub>DL,high</sub>	-40	1	39
	E-UTRA Band 11, 21	F <sub>DL,low</sub>	-	F <sub>DL,high</sub>	-50	1	39
	Frequency range	1884.5	-	1915.7	-41	0.3	8, 39
6	E-UTRA Band 1, 9, 11, 34	F <sub>DL,low</sub>	-	F <sub>DL,high</sub>	-50	1	
	Frequency range	860	-	875	-37	1	
	Frequency range	875	-	895	-50	1	
	Frequency range	1884.5	-	1919.6	-41	0.3	7
		1884.5	-	1915.7			8
7	E-UTRA Band 1, 2, 3, 4, 5, 7, 8, 12, 13, 14, 17, 20, 22, 26, 27, 28, 29, 30, 31, 32, 33, 34, 40, 42, 43, 50, 51, 52, 65, 66, 67, 68, 72, 74, 75, 76, 85, 87, 88 NR Band n77, n78	F <sub>DL,low</sub>	-	F <sub>DL,high</sub>	-50	1	
	Frequency range	2570	-	2575	+1.6	5	15, 21, 26
	Frequency range	2575	-	2595	-15.5	5	15, 21, 26
	Frequency range	2595	-	2620	-40	1	15, 21
8	E-UTRA Band 1, 20, 28, 31, 32, 33, 34, 38, 39, 40, 45, 50, 51, 65, 67, 68, 69, 72, 73, 74, 75, 76, 87, 88	F <sub>DL,low</sub>	-	F <sub>DL,high</sub>	-50	1	
	E-UTRA band 3, 7, 22, 41, 42, 43, 52 NR Band n77, n78, n79	F <sub>DL,low</sub>	-	F <sub>DL,high</sub>	-50	1	2
	E-UTRA Band 8	F <sub>DL,low</sub>	-	F <sub>DL,high</sub>	-50	1	15
	E-UTRA Band 11, 21	F <sub>DL,low</sub>	-	F <sub>DL,high</sub>	-50	1	23
	Frequency range	860	-	890	-40	1	15, 23

	Frequency range	1884.5	-	1915.7	-41	0.3	8, 23
9	E-UTRA Band 1, 3, 11, 18, 19, 21, 26, 28, 34	F <sub>DL,low</sub>	-	F <sub>DL,high</sub>	-50	1	
	E-UTRA Band 42	F <sub>DL,low</sub>	-	F <sub>DL,high</sub>	-50	1	2
	Frequency range	945	-	960	-50	1	
	Frequency range	1884.5	-	1915.7	-41	0.3	8
	Frequency range	2545	-	2575	-50	1	
	Frequency range	2595	-	2645	-50	1	
10	E-UTRA Band 2, 4, 5, 10, 12, 13, 14, 17, 24, 25, 26, 27, 28, 29, 30, 41, 43, 66, 70, 85	F <sub>DL,low</sub>	-	F <sub>DL,high</sub>	-50	1	
	E-UTRA Band 22, 42, NR Band n77	F <sub>DL,low</sub>	-	F <sub>DL,high</sub>	-50	1	2
11	E-UTRA Band 1, 3, 11, 18, 19, 21, 28, 34, 42, 65 NR Band n77, n78, n79	F <sub>DL,low</sub>	-	F <sub>DL,high</sub>	-50	1	
	Frequency range	945	-	960	-50	1	
	Frequency range	1884.5	-	1915.7	-41	0.3	8
	Frequency range	2545	-	2575	-50	1	
	Frequency range	2595	-	2645	-50	1	
12	E-UTRA Band 2, 5, 13, 14, 17, 24, 25, 26, 27, 30, 41, 48, 53, 71, 74	F <sub>DL,low</sub>	-	F <sub>DL,high</sub>	-50	1	
	E-UTRA Band 4, 50, 51, 66, 70, NR Band n77	F <sub>DL,low</sub>	-	F <sub>DL,high</sub>	-50	1	2
	E-UTRA Band 12, 85	F <sub>DL,low</sub>	-	F <sub>DL,high</sub>	-50	1	15
13	E-UTRA Band 2, 4, 5, 12, 13, 17, 25, 26, 27, 29, 41, 48, 50, 51, 53, 66, 70, 71, 74, 85	F <sub>DL,low</sub>	-	F <sub>DL,high</sub>	-50	1	
	E-UTRA Band 14	F <sub>DL,low</sub>	-	F <sub>DL,high</sub>	-50	1	15
	E-UTRA Band 24, 30, NR Band n77	F <sub>DL,low</sub>	-	F <sub>DL,high</sub>	-50	1	2
	Frequency range	769	-	775	-35	0.00625	15
	Frequency range	799	-	805	-35	0.00625	15
14	E-UTRA Band 2, 4, 5, 12, 13, 14, 17, 23, 24, 25, 26, 27, 29, 30, 41, 48, 53, 66, 70, 71, 85	F <sub>DL,low</sub>	-	F <sub>DL,high</sub>	-50	1	
	NR Band n77	F <sub>DL,low</sub>	-	F <sub>DL,high</sub>	-50	1	2
	Frequency range	769	-	775	-35	0.00625	12, 15
	Frequency range	799	-	805	-35	0.00625	12, 15
17	E-UTRA Band 2, 5, 13, 14, 17, 24, 25, 26, 27, 30, 41, 48, 71, 74	F <sub>DL,low</sub>	-	F <sub>DL,high</sub>	-50	1	
	E-UTRA Band 4, 50, 51, 53, 66, 70, NR Band n77	F <sub>DL,low</sub>	-	F <sub>DL,high</sub>	-50	1	2
	E-UTRA Band 12, 85	F <sub>DL,low</sub>	-	F <sub>DL,high</sub>	-50	1	15
18	E-UTRA Band 1, 3, 11, 21, 34, 42, 65 NR Band n79	F <sub>DL,low</sub>	-	F <sub>DL,high</sub>	-50	1	
	NR Band n77, n78	F <sub>DL,low</sub>	-	F <sub>DL,high</sub>	-50	1	2
	Frequency range	758	-	799	-50	1	
	Frequency range	799	-	803	-40	1	15
	Frequency range	860	-	890	-40	1	
	Frequency range	945	-	960	-50	1	
	Frequency range	1884.5	-	1915.7	-41	0.3	8
	Frequency range	2545	-	2575	-50	1	
	Frequency range	2595	-	2645	-50	1	
19	E-UTRA Band 1, 3, 11, 21, 28, 34, 42, 65 NR Band n79	F <sub>DL,low</sub>	-	F <sub>DL,high</sub>	-50	1	
	NR Band n77, n78	F <sub>DL,low</sub>	-	F <sub>DL,high</sub>	-50	1	2
	Frequency range	945	-	960	-50	1	
	Frequency range	1884.5	-	1915.7	-41	0.3	8
	Frequency range	2545	-	2575	-50	1	
	Frequency range	2595	-	2645	-50	1	

20	E-UTRA Band 1, 3, 7, 8, 22, 31, 32, 33, 34, 40, 43, 50, 51, 65, 67, 68, 72, 74, 75, 76, 87, 88	$F_{DL,low}$	-	$F_{DL,high}$	-50	1	
	E-UTRA Band 20	$F_{DL,low}$	-	$F_{DL,high}$	-50	1	15
	E-UTRA Band 38, 42, 52, 69 NR Band n77, n78	$F_{DL,low}$	-	$F_{DL,high}$	-50	1	2
	Frequency range	758	-	788	-50	1	
21	E-UTRA Band 1, 3, 18, 19, 28, 34, 42, 65 NR Band n77, n78, n79	$F_{DL,low}$	-	$F_{DL,high}$	-50	1	
	Frequency range	945	-	960	-50	1	
	Frequency range	1884.5	-	1915.7	-41	0.3	8
	Frequency range	2545	-	2575	-50	1	
22	E-UTRA Band 1, 3, 7, 8, 20, 26, 27, 28, 31, 32, 33, 34, 38, 39, 40, 43, 65, 67, 68, 69, 72, 75, 76, 87, 88	$F_{DL,low}$	-	$F_{DL,high}$	-50	1	
	Frequency range	3510	-	3525	-40	1	15
23	E-UTRA Band 4, 5, 12, 13, 14, 17, 23, 24, 26, 27, 29, 30, 41, 66	$F_{DL,low}$	-	$F_{DL,high}$	-50	1	
	Frequency range	3525	-	3590	-50	1	
24	E-UTRA Band 2, 4, 5, 12, 13, 14, 17, 24, 25, 26, 29, 30, 41, 48, 66, 70, 71, 85	$F_{DL,low}$	-	$F_{DL,high}$	-50	1	
	NR Band n77	$F_{DL,low}$	-	$F_{DL,high}$	-50	1	2
25	E-UTRA Band 4, 5, 12, 13, 14, 17, 24, 26, 27, 28, 29, 30, 41, 42, 48, 53, 66, 70, 71, 85	$F_{DL,low}$	-	$F_{DL,high}$	-50	1	
	E-UTRA Band 2	$F_{DL,low}$	-	$F_{DL,high}$	-50	1	15
	E-UTRA Band 25	$F_{DL,low}$	-	$F_{DL,high}$	-50	1	15
	E-UTRA Band 43, NR Band n77	$F_{DL,low}$	-	$F_{DL,high}$	-50	1	2
26	E-UTRA Band 1, 2, 3, 4, 5, 11, 12, 13, 14, 17, 18, 19, 21, 24, 25, 26, 29, 30, 31, 34, 39, 40, 42, 43, 48, 50, 51, 53, 65, 66, 70, 71, 73, 74, 85	$F_{DL,low}$	-	$F_{DL,high}$	-50	1	
	E-UTRA Band 41 NR Band n77, n78, n79	$F_{DL,low}$	-	$F_{DL,high}$	-50	1	2
	Frequency range	703	-	799	-50	1	
	Frequency range	799	-	803	-40	1	15
	Frequency range	945	-	960	-50	1	
27	E-UTRA Band 1, 2, 3, 4, 5, 7, 12, 13, 14, 17, 25, 26, 27, 29, 30, 31, 38, 40, 41, 42, 43, 65, 66, 73, 85	$F_{DL,low}$	-	$F_{DL,high}$	-50	1	
	E-UTRA Band 28	$F_{DL,low}$	-	790	-50	1	
	NR Band n77	$F_{DL,low}$	-	$F_{DL,high}$	-50	1	2
	Frequency range	799	-	805	-35	0.00625	
28	E-UTRA Band 1, 4, 22, 32, 42, 43, 50, 51, 52, 65, 66, 73, 74, 75, 76 NR Band n77, n78	$F_{DL,low}$	-	$F_{DL,high}$	-50	1	2
	E-UTRA Band 1	$F_{DL,low}$	-	$F_{DL,high}$	-50	1	19, 25
	E-UTRA Band 2, 3, 5, 7, 8, 18, 19, 20, 25, 26, 27, 31, 34, 38, 40, 41, 72, 87, 88 NR Band n79	$F_{DL,low}$	-	$F_{DL,high}$	-50	1	
	E-UTRA Band 11, 21	$F_{DL,low}$	-	$F_{DL,high}$	-50	1	19, 24
	Frequency range	470	-	694	-42	8	15, 35
	Frequency range	470	-	710	-26.2	6	34
	Frequency range	662	-	694	-26.2	6	15
	Frequency range	758	-	773	-32	1	15
Frequency range	773	-	803	-50	1		
30	E-UTRA Band 2, 4, 5, 7, 12, 13, 14, 17, 24, 25, 26, 27, 29, 30, 38, 41, 48, 53, 66, 70, 71, 85	$F_{DL,low}$	-	$F_{DL,high}$	-50	1	
	NR Band n77	$F_{DL,low}$	-	$F_{DL,high}$	-50	1	2
31	E-UTRA Band 1, 5, 7, 8, 20, 22, 26, 27, 28, 31, 32, 33, 34, 38, 40, 42, 43, 50, 51, 52, 65, 67, 68, 69, 74, 75, 76, 87, 88	$F_{DL,low}$	-	$F_{DL,high}$	-50	1	
	E-UTRA Band 3	$F_{DL,low}$	-	$F_{DL,high}$	-50	1	2

	Frequency range	470	-	694	-42	8	
...							
33	E-UTRA Band 1, 7, 8, 20, 22, 28, 31, 32, 34, 38, 40, 42, 43, 52, 65, 67, 69, 72, 73, 75, 76, 87, 88	F <sub>DL,low</sub>	-	F <sub>DL,high</sub>	-50	1	5
	E-UTRA Band 3	F <sub>DL,low</sub>	-	F <sub>DL,high</sub>	-50	1	15
34	E-UTRA Band 1, 3, 7, 8, 11, 18, 19, 20, 21, 22, 26, 28, 31, 32, 33, 38, 39, 40, 41, 42, 43, 44, 45, 50, 51, 52, 65, 67, 69, 72, 73, 74, 75, 76, 87, 88	F <sub>DL,low</sub>	-	F <sub>DL,high</sub>	-50	1	5
	NR Band n77	F <sub>DL,low</sub>	-	F <sub>DL,high</sub>	-50	1	2, 5
	Frequency range	1884.5	-	1915.7	-41	0.3	8
35							
36							
37							
38	E-UTRA Band 1, 2, 3, 4, 5, 8, 12, 13, 14, 17, 20, 22, 27, 28, 29, 30, 31, 32, 33, 34, 40, 42, 43, 50, 51, 52, 65, 66, 67, 68, 72, 74, 75, 76, 85, 87, 88	F <sub>DL,low</sub>	-	F <sub>DL,high</sub>	-50	1	
	Frequency range	2620	-	2645	-15.5	5	15, 22, 26
	Frequency range	2645	-	2690	-40	1	15, 22
39	E-UTRA Band 1, 8, 22, 26, 28, 34, 40, 41, 42, 44, 45, 50, 51, 52, 73, 74	F <sub>DL,low</sub>	-	F <sub>DL,high</sub>	-50	1	
	NR Band n79						
	NR Band n77, n78	F <sub>DL,low</sub>	-	F <sub>DL,high</sub>	-50	1	2
	Frequency range	1805	-	1855	-40	1	33
	Frequency range	1855	-	1880	-15.5	5	15, 26, 33
40	E-UTRA Band 1, 3, 5, 7, 8, 20, 22, 26, 27, 28, 31, 32, 33, 34, 38, 39, 41, 42, 43, 44, 45, 50, 51, 52, 65, 67, 68, 69, 72, 73, 74, 75, 76, 87, 88	F <sub>DL,low</sub>	-	F <sub>DL,high</sub>	-50	1	
	NR Band n77, n78						
	NR Band n79	F <sub>DL,low</sub>	-	F <sub>DL,high</sub>	-50	1	2
41	E-UTRA Band 1, 2, 3, 4, 5, 8, 12, 13, 14, 17, 24, 25, 26, 27, 28, 29, 30, 34, 39, 40, 42, 44, 45, 48, 50, 51, 52, 65, 66, 70, 71, 73, 74, 85	F <sub>DL,low</sub>	-	F <sub>DL,high</sub>	-50	1	
	NR Band n77, n78						
	E-UTRA Band 9, 11, 18, 19, 21	F <sub>DL,low</sub>	-	F <sub>DL,high</sub>	-50	1	30
	NR Band n79	F <sub>DL,low</sub>	-	F <sub>DL,high</sub>	-50	1	2
	Frequency range	1884.5	-	1915.7	-41	0.3	8, 30
42	E-UTRA Band 1, 2, 3, 4, 5, 7, 8, 11, 18, 19, 20, 21, 25, 26, 27, 28, 31, 32, 33, 34, 38, 40, 41, 44, 45, 50, 51, 65, 66, 67, 68, 69, 72, 73, 74, 75, 76, 87, 88	F <sub>DL,low</sub>	-	F <sub>DL,high</sub>	-50	1	
	NR Band n79						
	Frequency range	1884.5	-	1915.7	-41	0.3	8
43	E-UTRA Band 1, 2, 3, 4, 5, 7, 8, 20, 25, 26, 27, 28, 31, 32, 33, 34, 38, 40, 50, 51, 65, 66, 67, 68, 69, 72, 73, 74, 75, 76, 85, 87, 88	F <sub>DL,low</sub>	-	F <sub>DL,high</sub>	-50	1	
44	E-UTRA Band 1, 40, 42, 45	F <sub>DL,low</sub>	-	F <sub>DL,high</sub>	-50	1	2
	E-UTRA Band 3, 5, 8, 34, 39, 41, 73	F <sub>DL,low</sub>	-	F <sub>DL,high</sub>	-50	1	
45	E-UTRA Band 1, 3, 5, 8, 34, 39, 40, 41, 42, 44, 52, 73	F <sub>DL,low</sub>	-	F <sub>DL,high</sub>	-50	1	
...							
47	E-UTRA Band 1, 3, 5, 7, 8, 22, 26, 28, 34, 39, 40, 41, 42, 44, 45, 65, 68, 72, 73	F <sub>DL,low</sub>	-	F <sub>DL,high</sub>	-50	1	
	NR band n77, n78, n79						
	Frequency range	5925	-	5950	-30 EIRP	1	38, 40, 43
	Frequency range	5815	-	5855	-30 EIRP	1	38, 43, 45
48	E-UTRA Band 2, 4, 5, 12, 13, 14, 17, 24, 25, 26, 29, 30, 41, 50, 51, 66, 70, 71, 74, 85	F <sub>DL,low</sub>	-	F <sub>DL,high</sub>	-50	1	
50	E-UTRA Band 1, 2, 3, 4, 5, 7, 8, 12, 13, 17, 20, 26, 28, 29, 31, 34, 38, 39, 40, 41, 42, 43, 48, 52, 65, 66, 67, 68, 85	F <sub>DL,low</sub>	-	F <sub>DL,high</sub>	-50	1	



51	E-UTRA Band 1, 2, 3, 4, 5, 7, 8, 12, 13, 17, 20, 26, 28, 29, 31, 34, 38, 39, 40, 41, 42, 43, 48, 52, 65, 66, 67, 68, 85	$F_{DL\_low}$	-	$F_{DL\_high}$	-50	1	
52	E-UTRA Band 1, 3, 5, 7, 8, 20, 28, 31, 33, 34, 38, 39, 40, 41, 45, 47, 50, 51, 68, 72, 73, 74, 87, 88	$F_{DL\_low}$	-	$F_{DL\_high}$	-50	1	
53	E-UTRA Band 2, 4, 5, 12, 13, 14, 17, 24, 25, 26, 29, 30, 48, 66, 70, 71, 85, NR Band n77	$F_{DL\_low}$	-	$F_{DL\_high}$	-50	1	
65	E-UTRA Band 1, 3, 7, 8, 20, 22, 28, 31, 32, 38, 40, 42, 43, 50, 51, 65, 68, 69, 72, 74, 75, 76, 87, 88 NR Band n77, n78, n79	$F_{DL\_low}$	-	$F_{DL\_high}$	-50	1	
	E-UTRA Band 5, 11, 18, 19, 21, 26, 27, 41	$F_{DL\_low}$	-	$F_{DL\_high}$	-50	1	
	E-UTRA Band 34	$F_{DL\_low}$	-	$F_{DL\_high}$	-50	1	36
	Frequency range	1884.5	-	1915.7	-41	0.3	37
	Frequency range	1900	-	1915	-15.5	5	15, 26, 27
66	E-UTRA Band 2, 4, 5, 7, 12, 13, 14, 17, 24, 25, 26, 27, 28, 29, 30, 38, 41, 43, 50, 51, 53, 66, 70, 71, 74, 85	$F_{DL\_low}$	-	$F_{DL\_high}$	-50	1	
	E-UTRA Band 42, 48, NR Band n77	$F_{DL\_low}$	-	$F_{DL\_high}$	-50	1	2
68	E-UTRA Band 3, 7, 8, 20, 22, 28, 31, 38, 40, 42, 43, 47, 50, 51, 65, 72, 74, 87, 88	$F_{DL\_low}$	-	$F_{DL\_high}$	-50	1	
	E-UTRA Band 1, 52	$F_{DL\_low}$	-	$F_{DL\_high}$	-50	1	2
...							
70	E-UTRA Band 2, 4, 5, 12, 13, 14, 17, 24, 25, 26, 29, 30, 41, 48, 53, 66, 70, 71, 85	$F_{DL\_low}$	-	$F_{DL\_high}$	-50	1	
	NR Band n77	$F_{DL\_low}$	-	$F_{DL\_high}$	-50	1	2
71	E-UTRA Band 4, 5, 12, 13, 14, 17, 24, 26, 30, 48, 53, 66, 85	$F_{DL\_low}$	-	$F_{DL\_high}$	-50	1	
	E-UTRA Band 2, 25, 41, 70, NR Band n77	$F_{DL\_low}$	-	$F_{DL\_high}$	-50	1	2
	E-UTRA Band 29	$F_{DL\_low}$	-	$F_{DL\_high}$	-38	1	15
	E-UTRA Band 71	$F_{DL\_low}$	-	$F_{DL\_high}$	-50	1	15
72	E-UTRA Band 1, 7, 20, 22, 28, 31, 32, 33, 34, 38, 42, 43, 47, 52, 65, 68, 72, 87, 88	$F_{DL\_low}$	-	$F_{DL\_high}$	-50	1	
	E-UTRA Band 3, 8, 40	$F_{DL\_low}$	-	$F_{DL\_high}$	-50	1	2
	Frequency range	470	-	694	-42	8	
73	E-UTRA Band 1, 26, 28, 33, 34, 39, 41, 42, 43, 44, 45, 47, 52	$F_{DL\_low}$	-	$F_{DL\_high}$	-50	1	
	E-UTRA Band 3, 5, 8, 27, 40	$F_{DL\_low}$	-	$F_{DL\_high}$	-50	1	2
74	E-UTRA Band 1, 2, 3, 4, 5, 7, 8, 12, 13, 17, 18, 19, 20, 26, 28, 29, 31, 34, 38, 39, 40, 41, 42, 43, 48, 52, 65, 66, 67, 68, 85 NR Band n77, n78	$F_{DL\_low}$	-	$F_{DL\_high}$	-50	1	
	NR Band n79	$F_{DL\_low}$	-	$F_{DL\_high}$	-50	1	2
	Frequency range	1884.5	-	1915.7	-41	0.3	8
	Frequency range	1400	-	1427	-32	27	15, 41
	Frequency range	1475	-	1488	-50	1	42
85	E-UTRA Band 2, 5, 13, 14, 17, 24, 25, 26, 27, 30, 41, 48, 53, 71, 74	$F_{DL\_low}$	-	$F_{DL\_high}$	-50	1	
	E-UTRA Band 4, 51, 66, 70, NR Band n77	$F_{DL\_low}$	-	$F_{DL\_high}$	-50	1	2
	E-UTRA Band 12, 85	$F_{DL\_low}$	-	$F_{DL\_high}$	-50	1	15
87	E-UTRA Band 1, 3, 7, 8, 22, 28, 31, 32, 33, 34, 38, 40, 42, 43, 47, 52, 65, 68, 72	$F_{DL\_low}$	-	$F_{DL\_high}$	-50	1	
	E-UTRA Band, 20	$F_{DL\_low}$	-	$F_{DL\_high}$	-50	1	2
	E-UTRA Band 87, 88	$F_{DL\_low}$	-	$F_{DL\_high}$	-50	1	15
	Frequency range	470	-	694	-42	8	

88	E-UTRA Band 1, 3, 7, 8, 20, 22, 28, 31, 32, 33, 34, 38, 40, 42, 43, 47, 52, 65, 68, 72	$F_{DL\_low}$	-	$F_{DL\_high}$	-50	1	
	E-UTRA Band 87	$F_{DL\_low}$	-	$F_{DL\_high}$	-20	1	15
	E-UTRA Band 88	$F_{DL\_low}$	-	$F_{DL\_high}$	-50	1	15
	Frequency range	470	-	694	-42	8	

- NOTE 1:  $F_{DL\_low}$  and  $F_{DL\_high}$  refer to each E-UTRA frequency band specified in Table 5.5-1
- NOTE 2: As exceptions, measurements with a level up to the applicable requirements defined in Table 6.6.3.1-2 are permitted for each assigned E-UTRA carrier used in the measurement due to 2<sup>nd</sup>, 3<sup>rd</sup>, 4<sup>th</sup> [or 5<sup>th</sup>] harmonic spurious emissions. Due to spreading of the harmonic emission the exception is also allowed for the first 1 MHz frequency range immediately outside the harmonic emission on both sides of the harmonic emission. This results in an overall exception interval centred at the harmonic emission of  $(2\text{MHz} + N \times L_{CRB} \times 180\text{kHz})$ , where N is 2, 3, 4, [5] for the 2<sup>nd</sup>, 3<sup>rd</sup>, 4<sup>th</sup> [or 5<sup>th</sup>] harmonic respectively. The exception is allowed if the measurement bandwidth (MBW) totally or partially overlaps the overall exception interval.
- NOTE 3: N/A
- NOTE 4: N/A
- NOTE 5: For non synchronised TDD operation to meet these requirements some restriction will be needed for either the operating band or protected band
- NOTE 6: N/A
- NOTE 7: Applicable when co-existence with PHS system operating in 1884.5-1919.6MHz.
- NOTE 8: Applicable when co-existence with PHS system operating in 1884.5 -1915.7MHz.
- NOTE 9: N/A
- NOTE 10: N/A
- NOTE 11: Whether the applicable frequency range should be 793-805MHz instead of 799-805MHz is TBD
- NOTE 12: The emissions measurement shall be sufficiently power averaged to ensure a standard deviation < 0.5 dB
- NOTE 13: N/A
- NOTE 14: N/A
- NOTE 15: These requirements also apply for the frequency ranges that are less than  $F_{OOB}$  (MHz) in Table 6.6.3.1-1 and Table 6.6.3.1A-1 from the edge of the channel bandwidth.
- NOTE 16: N/A
- NOTE 17: N/A
- NOTE 18: N/A
- NOTE 19: Applicable when the assigned E-UTRA carrier is confined within 718 MHz and 748 MHz and when the channel bandwidth used is 5 or 10 MHz.
- NOTE 20: N/A
- NOTE 21: This requirement is applicable for any channel bandwidths within the range 2500 - 2570 MHz with the following restriction: for carriers of 15 MHz bandwidth when carrier centre frequency is within the range 2560.5 - 2562.5 MHz and for carriers of 20 MHz bandwidth when carrier centre frequency is within the range 2552 - 2560 MHz the requirement is applicable only for an uplink transmission bandwidth less than or equal to 54 RB.
- NOTE 22: This requirement is applicable for power class 3 UE for any channel bandwidths within the range 2570 - 2615 MHz with the following restriction: for carriers of 15 MHz bandwidth when carrier centre frequency is within the range 2605.5 - 2607.5 MHz and for carriers of 20 MHz bandwidth when carrier centre frequency is within the range 2597 - 2605 MHz the requirement is applicable only for an uplink transmission bandwidth less than or equal to 54 RB. For power class 2 UE for any channel bandwidths within the range 2570 - 2615 MHz, NS\_44 shall apply.  
For power class 2 or 3 UE for carriers with channel bandwidth overlapping the frequency range 2615 - 2620 MHz the requirement applies with the maximum output power configured to +19 dBm in the IE *P-Max*.
- NOTE 23: This requirement is applicable only for the following cases:  
- for carriers of 5 MHz channel bandwidth when carrier centre frequency ( $F_c$ ) is within the range  $902.5 \text{ MHz} \leq F_c < 907.5 \text{ MHz}$  with an uplink transmission bandwidth less than or equal to 20 RB  
- for carriers of 5 MHz channel bandwidth when carrier centre frequency ( $F_c$ ) is within the range  $907.5 \text{ MHz} \leq F_c \leq 912.5 \text{ MHz}$  without any restriction on uplink transmission bandwidth.  
- for carriers of 10 MHz channel bandwidth when carrier centre frequency ( $F_c$ ) is  $F_c = 910 \text{ MHz}$  with an uplink transmission bandwidth less than or equal to 32 RB with  $RB_{start} > 3$ .
- NOTE 24: As exceptions, measurements with a level up to the applicable requirement of -38 dBm/MHz is permitted for each assigned E-UTRA carrier used in the measurement due to 2<sup>nd</sup> harmonic spurious emissions. An exception is allowed if there is at least one individual RB within the transmission bandwidth (see Figure 5.6-1) for which the 2<sup>nd</sup> harmonic totally or partially overlaps the measurement bandwidth (MBW).
- NOTE 25: As exceptions, measurements with a level up to the applicable requirement of -36 dBm/MHz is permitted for each assigned E-UTRA carrier used in the measurement due to 3<sup>rd</sup> harmonic spurious emissions. An exception is allowed if there is at least one individual RB within the transmission bandwidth (see Figure 5.6-1) for which the 3<sup>rd</sup> harmonic totally or partially overlaps the measurement bandwidth (MBW).
- NOTE 26: For these adjacent bands, the emission limit could imply risk of harmful interference to UE(s) operating in the protected operating band.
- NOTE 27: This requirement is applicable for any channel bandwidths within the range 1920 - 1980 MHz with the following restriction: for carriers of 15 MHz bandwidth when carrier centre frequency is within the range 1927.5 - 1929.5 MHz and for carriers of 20 MHz bandwidth when carrier centre

frequency is within the range 1930 - 1938 MHz the requirement is applicable only for an uplink transmission bandwidth less than or equal to 54 RB.

NOTE 28: N/A

NOTE 29: N/A

NOTE 30: This requirement applies when the E-UTRA carrier is confined within 2545-2575MHz or 2595-2645MHz and the channel bandwidth is 10 or 20 MHz

NOTE 31: N/A

NOTE 32: Void

NOTE 33: This requirement is only applicable for carriers with bandwidth confined within 1885-1920 MHz (requirement for carriers with at least 1RB confined within 1880 - 1885 MHz is not specified). This requirement applies for an uplink transmission bandwidth less than or equal to 54 RB for carriers of 15 MHz bandwidth when carrier center frequency is within the range 1892.5 - 1894.5 MHz and for carriers of 20 MHz bandwidth when carrier center frequency is within the range 1895 - 1903 MHz.

NOTE 34: This requirement is applicable for 5 and 10 MHz E-UTRA channel bandwidth allocated within 718-728MHz. For carriers of 10 MHz bandwidth, this requirement applies for an uplink transmission bandwidth less than or equal to 30 RB with  $RB_{start} > 1$  and  $RB_{start} < 48$ .

NOTE 35: This requirement is applicable in the case of a 10 MHz E-UTRA carrier confined within 703 MHz and 733 MHz, otherwise the requirement of -25 dBm with a measurement bandwidth of 8 MHz applies.

NOTE 36: This requirement is applicable for E-UTRA channel bandwidth allocated within 1920-1980 MHz.

NOTE 37: Applicable when the upper edge of the channel bandwidth frequency is greater than 1980MHz.

NOTE 38: Applicable when NS\_33 or NS\_34 is configured by the pre-configured radio parameters.

NOTE 39: Applicable only when the assigned E-UTRA carrier is confined within 824 MHz and 849 MHz for UE category M1, M2 and UE category NB1 and NB2.

NOTE 40: In the frequency range  $x-5950$ MHz, SE requirement of -30dBm/MHz should be applied; where  $x = \max(5925, f_c + 15)$ , where  $f_c$  is the channel centre frequency.

NOTE 41: Applicable for all bandwidths, and when the lower edge of the assigned E-UTRA UL channel bandwidth frequency is greater than or equal to 1427 MHz + the channel BW assigned for 1.4, 3, 5 and 10 MHz bandwidth, and when the lower edge of the assigned E-UTRA UL channel bandwidth frequency is greater than or equal to 1440 MHz for 15 and 20 MHz bandwidth. This requirement shall be verified with UE transmission power of 15 dBm.

NOTE 42: Applicable for 1.4, 3 and 5 MHz bandwidth, and when the upper edge of the assigned E-UTRA UL channel bandwidth frequency is less than or equal to 1467 MHz assigned for 10 MHz bandwidth, and when the upper edge of the assigned E-UTRA UL channel bandwidth frequency is less than or equal to 1463.8 MHz for 15 MHz bandwidth, and when the upper edge of the assigned E-UTRA UL channel bandwidth frequency is less than or equal to 1460.8 MHz for 20 MHz bandwidth.

NOTE 43: The EIRP requirement is converted to conducted requirement depend on the supported post antenna connector gain  $G_{post\ connector}$  declared by the UE following the principle described in annex I.

NOTE 44: For category NB1 and NB2 UE when carrier centre frequency is 1920.1 MHz, in case of single-tone uplink transmission the requirement is applicable only for sub-carrier index  $> 2$ .

NOTE 45: Resolution BW is 10% of the measurement BW and the result should be integrated to achieve the measurement bandwidth. The sweep time shall be set at least as  $(\text{sweep points}) \times (\text{symbol length})$  to improve the measurement accuracy.

NOTE: The restriction on the maximum uplink transmission to 54 RB in Notes 21, 22, and 27 of Table 6.6.3.2-1 and the restriction on the single-tone uplink transmission to sub-carrier index  $> 2$  in Note 44 of Table 6.6.3.2-1 are intended for conformance testing and may be applied to network operation to facilitate coexistence when the aggressor and victim bands are deployed in the same geographical area. The applicable spurious emission requirement of -15.5 dBm/5MHz is a least restrictive technical condition for FDD/TDD coexistence and may have to be revised in the future.

When "NS\_33" or "NS 34" is configured from pre-configured radio parameters or the cell and the indication from upper layers has indicated that the UE is within the protection zone of CEN DSRC devices or HDR DSRC devices, the power of any V2X UE emission shall fulfil either one of the two set of conditions.

	Maximum Transmission Power (dBm EIRP)	Emission Limit in Frequency Range 5795-5815 (dBm/MHz EIRP)
Condition 1	10	-65
Condition 2	10	-45

### 6.6.3.2A Spurious emission band UE co-existence for CA

This clause specifies the requirements for the specified carrier aggregation configurations for coexistence with protected bands.

NOTE: For measurement conditions at the edge of each frequency range, the lowest frequency of the measurement position in each frequency range should be set at the lowest boundary of the frequency range plus MBW/2. The highest frequency of the measurement position in each frequency range should be set at the highest boundary of the frequency range minus MBW/2. MBW denotes the measurement bandwidth defined for the protected band.

For inter-band carrier aggregation with the uplink assigned to two E-UTRA bands, the requirements in Table 6.6.3.2A-0 apply on each component carrier with all component carriers are active.

NOTE: For inter-band carrier aggregation with uplink assigned to two E-UTRA bands the requirements in Table 6.6.3.2A-0 could be verified by measuring spurious emissions at the specific frequencies where second and third order intermodulation products generated by the two transmitted carriers can occur; in that case, the requirements for remaining applicable frequencies in Table 6.6.3.2A-0 would be considered to be verified by the measurements verifying the one uplink inter-band CA UE to UE co-existence requirements.

**Table 6.6.3.2A-0: Requirements for uplink inter-band carrier aggregation (two bands)**

E-UTRA CA Configuration	Spurious emission						
	Protected band	Frequency range (MHz)		Maximum Level (dBm)	MBW (MHz)	NOTE	
CA_1-3	E-UTRA Band 1, 5, 7, 8, 11, 18, 19, 20, 21, 26, 27, 28, 31, 32, 38, 40, 41, 43, 44, 50, 51, 65, 67, 72, 73, 74, 75, 76 NR Band n79	F <sub>DL_low</sub>	-	F <sub>DL_high</sub>	-50	1	
	E-UTRA band 3, 34	F <sub>DL_low</sub>	-	F <sub>DL_high</sub>	-50	1	3
	E-UTRA band 22, 42, 52 NR Band n77, n78	F <sub>DL_low</sub>	-	F <sub>DL_high</sub>	-50	1	2
	Frequency range	1880		1895	-40	1	3,12
	Frequency range	1895		1915	-15.5	5	3, 12, 13
	Frequency range	1915		1920	+1.6	5	3, 12, 13
CA_1-5	E-UTRA Band 1, 5, 7, 8, 22, 28, 31, 38, 40, 42, 43, 50, 51, 65, 73, 74 NR Band n77, n78, n79	F <sub>DL_low</sub>	-	F <sub>DL_high</sub>	-50	1	
	E-UTRA band 3,34	F <sub>DL_low</sub>	-	F <sub>DL_high</sub>	-50	1	3
	E-UTRA band 26	859	-	869	-27	1	
	E-UTRA band 41, 52	F <sub>DL_low</sub>	-	F <sub>DL_high</sub>	-50	1	2
CA_1-7	E-UTRA Band 1, 5, 7, 8, 20, 22, 26, 27, 28, 31,32, 40, 42, 43, 50, 51, 52, 65, 67, 72, 74, 75, 76 NR Band n78	F <sub>DL_low</sub>	-	F <sub>DL_high</sub>	-50	1	
	E-UTRA band 3, 34	F <sub>DL_low</sub>	-	F <sub>DL_high</sub>	-50	1	3
	NR Band n77	F <sub>DL_low</sub>	-	F <sub>DL_high</sub>	-50	1	2
	Frequency range	1880		1895	-40	1	3,12
	Frequency range	1895		1915	-15.5	5	3, 12, 13
	Frequency range	1915		1920	+1.6	5	3, 12, 13
	Frequency range	2570	-	2575	+1.6	5	3, 13, 14
	Frequency range	2575	-	2595	-15.5	5	3, 13, 14
	Frequency range	2595	-	2620	-40	1	3, 14
CA_1-8	E-UTRA Band 1, 20, 28, 31, 32, 38, 40, 50, 51, 65, 67, 72, 73, 74, 75, 76	F <sub>DL_low</sub>	-	F <sub>DL_high</sub>	-50	1	
	E-UTRA band 3, 7, 22, 41, 42, 43, 52 NR Band n77, n78, n79	F <sub>DL_low</sub>	-	F <sub>DL_high</sub>	-50	1	2
	E-UTRA Band 8, 34	F <sub>DL_low</sub>	-	F <sub>DL_high</sub>	-50	1	3
	E-UTRA band 11, 21	F <sub>DL_low</sub>	-	F <sub>DL_high</sub>	-50	1	11
	Frequency range	860	-	890	-40	1	3, 11
	Frequency range	1880		1895	-40	1	3,12
	Frequency range	1895		1915	-15.5	5	3, 12, 13
	Frequency range	1915		1920	+1.6	5	3, 12, 13
CA_1-11	E-UTRA Band 1, 3, 11, 18, 19, 21, 28, 34, 42, 65 NR Band n77, n78, n79	F <sub>DL_low</sub>	-	F <sub>DL_high</sub>	-50	1	
	Frequency range	945	-	960	-50	1	
	Frequency range	2545	-	2575	-50	1	
CA_1-18	Frequency range	2595	-	2645	-50	1	
	E-UTRA Band 1, 3, 11, 21, 42, 65 NR Band n79	F <sub>DL_low</sub>	-	F <sub>DL_high</sub>	-50	1	
	E-UTRA Band 34	F <sub>DL_low</sub>	-	F <sub>DL_high</sub>	-50	1	3
	NR Band n77, n78	F <sub>DL_low</sub>	-	F <sub>DL_high</sub>	-50	1	2
	Frequency range	758	-	799	-50	1	
	Frequency range	799	-	803	-40	1	3
	Frequency range	860	-	890	-40	1	
	Frequency range	945	-	960	-50	1	
Frequency range	2545	-	2575	-50	1		

	Frequency range	2595	-	2645	-50	1	
CA_1-19	E-UTRA Band 1, 3, 11, 21, 28, 42, 65 NR Band n79	$F_{DL\_low}$	-	$F_{DL\_high}$	-50	1	
	E-UTRA Band 34	$F_{DL\_low}$	-	$F_{DL\_high}$	-50	1	3
	NR Band n77, n78	$F_{DL\_low}$	-	$F_{DL\_high}$	-50	1	2
	Frequency range	945	-	960	-50	1	
	Frequency range	2545	-	2575	-50	1	
	Frequency range	2595	-	2645	-50	1	
CA_1-20	E-UTRA Band 1, 3, 7, 8, 22, 31, 32, 34, 40, 42, 43, 50, 51, 65, 67, 68, 72, 75, 76	$F_{DL\_low}$	-	$F_{DL\_high}$	-50	1	
	E-UTRA Band 20	$F_{DL\_low}$	-	$F_{DL\_high}$	-50	1	3
	E-UTRA Band 38, 69 NR Band n77, n78	$F_{DL\_low}$	-	$F_{DL\_high}$	-50	1	2
	Frequency range	758	-	788	-50	1	
CA_1-21	E-UTRA Band 1, 3, 18, 19, 28, 34, 42, 65 NR Band n77, n78, n79	$F_{DL\_low}$	-	$F_{DL\_high}$	-50	1	
	Frequency range	945	-	960	-50	1	
	Frequency range	2545	-	2575	-50	1	
	Frequency range	2595	-	2645	-50	1	
CA_1-26	E-UTRA Band 1, 5, 7, 11, 18, 19, 21, 22, 26, 31, 38, 40, 42, 43, 50, 51, 65, 73, 74 NR Band n77, n78, n79	$F_{DL\_low}$	-	$F_{DL\_high}$	-50	1	
	Frequency range	1880	-	1895	-40	1	3, 12
	Frequency range	1895	-	1915	-15.5	5	3, 12, 13
	Frequency range	1915	-	1920	+1.6	5	3, 12, 13
	Frequency range	945	-	960	-50	1	
	E-UTRA Band 41	$F_{DL\_low}$	-	$F_{DL\_high}$	-50	1	2
	E-UTRA Band 3, 34	$F_{DL\_low}$	-	$F_{DL\_high}$	-50	1	3
	Frequency range	703	-	799	-50	1	
		799	-	803	-40	1	3
CA_1-28	E-UTRA Band 3, 5, 7, 8, 18, 19, 20, 26, 27, 31, 32, 38, 40, 41, 50, 51, 72, 73, 74	$F_{DL\_low}$	-	$F_{DL\_high}$	-50	1	
	E-UTRA Band 22, 42, 43, 52, 75, 76 NR Band n77, n78, n79	$F_{DL\_low}$	-	$F_{DL\_high}$	-50	1	2
	E-UTRA Band 34	$F_{DL\_low}$	-	$F_{DL\_high}$	-50	1	3
	E-UTRA Band 11, 21	$F_{DL\_low}$	-	$F_{DL\_high}$	-50	1	5, 21
	E-UTRA Band 1, 65	$F_{DL\_low}$	-	$F_{DL\_high}$	-50	1	5, 6
	Frequency range	470	-	694	-42	8	3, 22
	Frequency range	470	-	710	-26.2	6	23
	Frequency range	758	-	773	-32	1	3
	Frequency range	773	-	803	-50	1	
	Frequency range	662	-	694	-26.2	6	3
	Frequency range	1880	-	1895	-40	1	3, 12
	Frequency range	1895	-	1915	-15.5	5	3, 12, 13
	Frequency range	1915	-	1920	+1.6	5	3, 12, 13
	CA_1-41	E-UTRA Band 1, 3, 5, 8, 26, 27, 28, 40, 42, 44, 45, 50, 51, 52, 65, 73, 74 NR Band n78	$F_{DL\_low}$	-	$F_{DL\_high}$	-50	1
E-UTRA Band 34		$F_{DL\_low}$	-	$F_{DL\_high}$	-50	1	3
NR Band n77, n79		$F_{DL\_low}$	-	$F_{DL\_high}$	-50	1	2
Frequency range		1880	-	1895	-40	1	3, 12



	Frequency range	1895	1915	-15.5	5	3, 12, 13
	Frequency range	1915	1920	+1.6	5	3, 12, 13
	E-UTRA Band 11, 18, 19, 21	F <sub>DL_low</sub>	F <sub>DL_high</sub>	-50	1	30
CA_1-42	E-UTRA Band 1, 5, 7, 8, 11, 18, 19, 20, 21, 26, 27, 28, 31, 32, 38, 40, 41, 44, 50, 51, 65, 67, 72, 73, 74, 75, 76 NR Band n79	F <sub>DL_low</sub>	F <sub>DL_high</sub>	-50	1	
	E-UTRA Band 3, 34	F <sub>DL_low</sub>	F <sub>DL_high</sub>	-50	1	3
	Frequency range	1880	1895	-40	1	3,12
	Frequency range	1895	1915	-15.5	5	3, 12, 13
	Frequency range	1915	1920	+1.6	5	3, 12, 13
CA_2-4	E-UTRA Band 4, 5, 12, 13, 14, 17, 22, 24, 26, 27, 28, 29, 30, 41, 50, 51, 53, 66, 70, 71, 74, 85	F <sub>DL_low</sub>	F <sub>DL_high</sub>	-50	1	
	E-UTRA Band 2, 25	F <sub>DL_low</sub>	F <sub>DL_high</sub>	-50	1	3
	E-UTRA Band 42, 43, NR Band n77	F <sub>DL_low</sub>	F <sub>DL_high</sub>	-50	1	2
CA_2-5	E-UTRA Band 4, 5, 12, 13, 14, 17, 24, 28, 29, 30, 42, 50, 51, 53, 66, 70, 71, 74, 85	F <sub>DL_low</sub>	F <sub>DL_high</sub>	-50	1	
	E-UTRA Band 2, 25	F <sub>DL_low</sub>	F <sub>DL_high</sub>	-50	1	3
	E-UTRA Band 26	859	869	-27	1	
	E-UTRA Band 41, 43, NR Band n77	F <sub>DL_low</sub>	F <sub>DL_high</sub>	-50	1	2
CA_2-7	E-UTRA Band 2, 4, 5, 7, 12, 13, 14, 17, 26, 27, 29, 30, 42, 50, 51, 65, 66, 70, 74, 85	F <sub>DL_low</sub>	F <sub>DL_high</sub>	-50	1	
	E-UTRA Band 43	F <sub>DL_low</sub>	F <sub>DL_high</sub>	-50	1	2
CA_2-12	E-UTRA Band 5, 13, 14, 17, 24, 26, 27, 30, 41, 50, 53, 71, 74	F <sub>DL_low</sub>	F <sub>DL_high</sub>	-50	1	
	E-UTRA Band 2, 12, 25, 85	F <sub>DL_low</sub>	F <sub>DL_high</sub>	-50	1	3
	E-UTRA Band 4, 51, 66, 70, NR Band n77	F <sub>DL_low</sub>	F <sub>DL_high</sub>	-50	1	2
CA_2-13	E-UTRA Band 4, 5, 12, 13, 17, 22, 26, 27, 29, 41, 42, 50, 51, 53, 66, 70, 71, 74, 85	F <sub>DL_low</sub>	F <sub>DL_high</sub>	-50	1	
	E-UTRA Band 2, 14, 25	F <sub>DL_low</sub>	F <sub>DL_high</sub>	-50	1	3
	E-UTRA Band 24, 30, 43, NR Band n77	F <sub>DL_low</sub>	F <sub>DL_high</sub>	-50	1	2
	Frequency range	769	775	-35	0.00625	3
	Frequency range	799	805	-35	0.00625	3
CA_2-14	E-UTRA Band 4, 5, 12, 13, 14, 17, 24, 26, 27, 29, 30, 41, 48, 53, 66, 70, 71, 85	F <sub>DL_low</sub>	F <sub>DL_high</sub>	-50	1	
	E-UTRA Band 2, 25	F <sub>DL_low</sub>	F <sub>DL_high</sub>	-50	1	3
	NR Band n77	F <sub>DL_low</sub>	F <sub>DL_high</sub>	-50	1	2
	Frequency range	769	775	-35	0.00625	3
	Frequency range	799	805	-35	0.00625	3, 9
CA_2-48	E-UTRA Band 4, 5, 12, 13, 14, 17, 24, 25, 26, 29, 30, 41, 50, 51, 53, 66, 70, 71, 74, 85	F <sub>DL_low</sub>	F <sub>DL_high</sub>	-50	1	
CA_2-49	E-UTRA Band 4, 5, 12, 13, 14, 17, 24, 25, 26, 29, 30, 41, 50, 51, 53, 66, 70, 71, 74, 85	F <sub>DL_low</sub>	F <sub>DL_high</sub>	-50	1	
CA_3-5	E-UTRA Band 1, 5, 7, 8, 22, 28, 31, 38, 40, 42, 43, 50, 51, 65, 73, 74	F <sub>DL_low</sub>	F <sub>DL_high</sub>	-50	1	
	E-UTRA band 3,34	F <sub>DL_low</sub>	F <sub>DL_high</sub>	-50	1	3
	E-UTRA Band 52	F <sub>DL_low</sub>	F <sub>DL_high</sub>	-50	1	2
	E-UTRA band 26	859	869	-27	1	
CA_3-7	E-UTRA Band 1, 5, 7, 8, 20, 26, 27, 28, 31, 32, 33, 34, 40, 43, 44, 50, 51, 65, 67, 72, 74, 75, 76	F <sub>DL_low</sub>	F <sub>DL_high</sub>	-50	1	
	E-UTRA band 3	F <sub>DL_low</sub>	F <sub>DL_high</sub>	-50	1	3
	E-UTRA band 22, 42, 52 NR Band n77, n78, n79	F <sub>DL_low</sub>	F <sub>DL_high</sub>	-50	1	2

	Frequency range	2570	-	2575	+1.6	5	3, 13, 14
	Frequency range	2575	-	2595	-15.5	5	3, 13, 14
	Frequency range	2595	-	2620	-40	1	3, 14
CA_3-8	E-UTRA Band 1, 20, 28, 31, 32, 33, 34, 38, 39, 40, 44, 50, 51, 65, 67, 72, 73, 74, 75, 76	F <sub>DL_low</sub>	-	F <sub>DL_high</sub>	-50	1	
	E-UTRA band 3, 8	F <sub>DL_low</sub>	-	F <sub>DL_high</sub>	-50	1	2, 3
	E-UTRA band 11, 21	F <sub>DL_low</sub>	-	F <sub>DL_high</sub>	-50	1	10, 11
	E-UTRA band 7, 22, 41, 42, 43, 52 NR Band n77, n78, n79	F <sub>DL_low</sub>	-	F <sub>DL_high</sub>	-50	1	2
	Frequency range	1884.5	-	1915.7	-41	0.3	4, 10, 11
	Frequency range	860	-	890	-40	1	3, 11, 17
CA_3A-11A	E-UTRA Band 1, 18, 19, 28, 34, 65	F <sub>DL_low</sub>	-	F <sub>DL_high</sub>	-50	1	
	E-UTRA band 3	F <sub>DL_low</sub>	-	F <sub>DL_high</sub>	-50	1	3
	E-UTRA Band 42	F <sub>DL_low</sub>	-	F <sub>DL_high</sub>	-50	1	2
	Frequency range	945	-	960	-50	1	
	Frequency range	1884.5	-	1915.7	-41	0.3	4
	Frequency range	2545	-	2575	-50	1	
	Frequency range	2595	-	2645	-50	1	
CA_3-18	E-UTRA Band 1, 3, 11, 21, 28, 34, 65 NR Band n77, n78, n79	F <sub>DL_low</sub>	-	F <sub>DL_high</sub>	-50	1	
	Frequency range	945	-	960	-50	1	
	Frequency range	1884.5	-	1915.7	-41	0.3	4
	Frequency range	2545	-	2575	-50	1	
	Frequency range	2595	-	2645	-50	1	
CA_3-19	E-UTRA Band 1, 11, 21, 28, 65	F <sub>DL_low</sub>	-	F <sub>DL_high</sub>	-50	1	
	E-UTRA Band 3, 34	F <sub>DL_low</sub>	-	F <sub>DL_high</sub>	-50	1	3
	E-UTRA Band 42 NR Band n77, n78, n79	F <sub>DL_low</sub>	-	F <sub>DL_high</sub>	-50	1	2
	Frequency range	945	-	960	-50	1	
	Frequency range	1884.5	-	1915.7	-41	0.3	3, 4
	Frequency range	2545	-	2575	-50	1	
	Frequency range	2595	-	2645	-50	1	
CA_3-20	E-UTRA Band 1, 7, 8, 31, 32, 33, 34, 40, 43, 50, 51, 65, 67, 72, 74, 75, 76	F <sub>DL_low</sub>	-	F <sub>DL_high</sub>	-50	1	
	E-UTRA Band 3, 20	F <sub>DL_low</sub>	-	F <sub>DL_high</sub>	-50	1	3
	E-UTRA Band 22, 38, 42, 52	F <sub>DL_low</sub>	-	F <sub>DL_high</sub>	-50	1	2
	Frequency range	758	-	788	-50	1	
CA_3-21	E-UTRA Band 1, 18, 19, 28, 34, 65 NR Band n77, n78, n79	F <sub>DL_low</sub>	-	F <sub>DL_high</sub>	-50	1	
	E-UTRA band 3	F <sub>DL_low</sub>	-	F <sub>DL_high</sub>	-50	1	3
	E-UTRA Band 42	F <sub>DL_low</sub>	-	F <sub>DL_high</sub>	-50	1	2
	Frequency range	945	-	960	-50	1	
	Frequency range	1884.5	-	1915.7	-41	0.3	4
	Frequency range	2545	-	2575	-50	1	
	Frequency range	2595	-	2645	-50	1	
CA_3-26	E-UTRA Band 1, 5, 7, 11, 18, 19, 21, 26, 34, 39, 40, 43, 50, 51, 65, 73, 74	F <sub>DL_low</sub>	-	F <sub>DL_high</sub>	-50	1	
	E-UTRA band 3	F <sub>DL_low</sub>	-	F <sub>DL_high</sub>	-50	1	3
	E-UTRA band 22, 41, 42 NR Band n77, n78, n79	F <sub>DL_low</sub>	-	F <sub>DL_high</sub>	-50	1	2
	Frequency range	1884.5	-	1915.7	-41	0.3	4
	Frequency range	703	-	799	-50	1	
	Frequency range	799	-	803	-40	1	3
	Frequency range	945	-	960	-50	1	

CA_3-28	E-UTRA Band 1, 11, 18, 19, 21, 22, 32, 42, 43, 50, 51, 52, 65, 74, 75, 76 NR Band n77, n78, n79	F <sub>DL_low</sub>	-	F <sub>DL_high</sub>	-50	1	2
	E-UTRA Band 1	F <sub>DL_low</sub>	-	F <sub>DL_high</sub>	-50	1	5, 6
	E-UTRA band 3	F <sub>DL_low</sub>	-	F <sub>DL_high</sub>	-50	1	3
	E-UTRA Band 5, 7, 8, 20, 26, 27, 31, 34, 38, 40, 41, 72, 73	F <sub>DL_low</sub>	-	F <sub>DL_high</sub>	-50	1	
	Frequency range	470	-	710	-26.2	6	23
	Frequency range	758	-	773	-32	1	3
	Frequency range	773	-	803	-50	1	
Frequency range	1884.5	-	1915.7	-41	0.3	4, 5	
CA_3-40	E-UTRA Band 1, 5, 7, 8, 20, 26, 27, 28, 31, 32, 33, 34, 38, 39, 41, 43, 44, 45, 50, 51, 65, 67, 68, 69, 72, 73, 75, 76	F <sub>DL_low</sub>	-	F <sub>DL_high</sub>	-50	1	
	E-UTRA Band 3	F <sub>DL_low</sub>	-	F <sub>DL_high</sub>	-50	1	3
	E-UTRA Band 22, 42, 52 NR Band n77, n78, n79	F <sub>DL_low</sub>	-	F <sub>DL_high</sub>	-50	1	2
	Frequency range	1884.5	-	1915.7	-41	0.3	
CA_3-41	E-UTRA Band 1, 5, 8, 26, 28, 33, 34, 39, 40, 44, 45, 50, 51, 65, 73, 74 NR Band n77, n78, n79	F <sub>DL_low</sub>	-	F <sub>DL_high</sub>	-50	1	
	E-UTRA Band 3	F <sub>DL_low</sub>	-	F <sub>DL_high</sub>	-50	1	3
	E-UTRA Band 11, 18, 19, 21	F <sub>DL_low</sub>	-	F <sub>DL_high</sub>	-50	1	18
	Frequency range	1884.5	-	1915.7	-41	0.3	4, 18
CA_3-42	E-UTRA Band 1, 5, 7, 8, 20, 26, 27, 28, 31, 32, 33, 34, 38, 40, 41, 44, 45, 50, 51, 65, 67, 72, 73, 74, 75, 76 NR Band n79	F <sub>DL_low</sub>	-	F <sub>DL_high</sub>	-50	1	
	E-UTRA Band 3	F <sub>DL_low</sub>	-	F <sub>DL_high</sub>	-50	1	3
	E-UTRA Band 11, 18, 19, 21	F <sub>DL_low</sub>	-	F <sub>DL_high</sub>	-50	1	13
	Frequency range	1884.5	-	1915.7	-41	0.3	4
CA_4-5	E-UTRA Band 2, 4, 5, 7, 12, 13, 14, 17, 24, 25, 28, 29, 30, 43, 50, 51, 53, 66, 70, 71, 74, 85	F <sub>DL_low</sub>	-	F <sub>DL_high</sub>	-50	1	
	E-UTRA Band 26	859	-	869	-27	1	
	E-UTRA band 41, 42, NR Band n77	F <sub>DL_low</sub>	-	F <sub>DL_high</sub>	-50	1	2
CA_4-7	E-UTRA Band 2, 4, 5, 7, 12, 13, 14, 17, 26, 27, 28, 29, 30, 43, 50, 51, 66, 74, 85	F <sub>DL_low</sub>	-	F <sub>DL_high</sub>	-50	1	
	E-UTRA band 42	F <sub>DL_low</sub>	-	F <sub>DL_high</sub>	-50	1	2
	Frequency range	2570	-	2575	+1.6	5	3, 13, 14
	Frequency range	2575	-	2595	-15.5	5	3, 13, 14
CA_4-12	Frequency range	2595	-	2620	-40	1	3, 14
	E-UTRA Band 2, 5, 7, 13, 14, 17, 22, 24, 25, 26, 27, 30, 41, 43, 50, 53, 71, 74	F <sub>DL_low</sub>	-	F <sub>DL_high</sub>	-50	1	
	E-UTRA Band 4, 42, 51, 66, 70, NR Band n77	F <sub>DL_low</sub>	-	F <sub>DL_high</sub>	-50	1	2
	E-UTRA Band 12, 85	F <sub>DL_low</sub>	-	F <sub>DL_high</sub>	-50	1	3
CA_4-13	E-UTRA Band 2, 4, 5, 7, 12, 13, 17, 22, 25, 26, 27, 29, 41, 43, 50, 51, 53, 66, 70, 71, 74, 85	F <sub>DL_low</sub>	-	F <sub>DL_high</sub>	-50	1	
	E-UTRA Band 14	F <sub>DL_low</sub>	-	F <sub>DL_high</sub>	-50	1	3
	E-UTRA Band 24, 30, 42, NR Band n77	F <sub>DL_low</sub>	-	F <sub>DL_high</sub>	-50	1	2
	Frequency range	769	-	775	-35	0.00625	3
	Frequency range	799	-	805	-35	0.00625	3

CA_4-17	E-UTRA Band 2, 5, 7, 13, 14, 17, 22, 24, 25, 26, 27, 30, 41, 43, 50, 53, 71, 74	F <sub>DL_low</sub>	-	F <sub>DL_high</sub>	-50	1	
	E-UTRA Band 4, 42, 51, 66, 70, NR Band n77	F <sub>DL_low</sub>	-	F <sub>DL_high</sub>	-50	1	2
	E-UTRA Band 12, 85	F <sub>DL_low</sub>	-	F <sub>DL_high</sub>	-50	1	3
CA_4-28	E-UTRA Band 2, 5, 7, 14, 24, 25, 26, 27, 30, 41, 48, 53, 70, 71	F <sub>DL_low</sub>	-	F <sub>DL_high</sub>	-50	1	
	E-UTRA Band 4, 42, 43, 50, 51, 66, 74	F <sub>DL_low</sub>	-	F <sub>DL_high</sub>	-50	1	2
	Frequency range	470	-	710	-26.2	6	23
	Frequency range	758	-	773	-32	1	3
	Frequency range	773	-	803	-50	1	
CA_5-7	E-UTRA Band 1, 2, 3, 4, 5, 7, 8, 12, 13, 14, 17, 22, 28, 29, 30, 31, 40, 42, 43, 50, 51, 65, 66, 74, 85	F <sub>DL_low</sub>	-	F <sub>DL_high</sub>	-50	1	
	E-UTRA Band 52 NR Band n77, n78	F <sub>DL_low</sub>	-	F <sub>DL_high</sub>	-50	1	2
	E-UTRA band 26	859	-	869	-27	1	
	Frequency range	2570	-	2575	+1.6	5	3, 13, 14
	Frequency range	2575	-	2595	-15.5	5	3, 13, 14
	Frequency range	2595	-	2620	-40	1	3, 14
CA_5-12	E-UTRA Band 2, 5, 13, 14, 17, 22, 24, 25, 30, 31, 42, 43, 50, 53, 71, 74	F <sub>DL_low</sub>	-	F <sub>DL_high</sub>	-50	1	
	E-UTRA band 4, 41, 51, 66, 70, NR Band n77	F <sub>DL_low</sub>	-	F <sub>DL_high</sub>	-50	1	2
	E-UTRA band 26	859	-	869	-27	1	
	E-UTRA band 12, 85	F <sub>DL_low</sub>	-	F <sub>DL_high</sub>	-50	1	3
CA_5-17	E-UTRA Band 2, 5, 13, 14, 17, 22, 24, 25, 30, 31, 42, 43, 50, 53, 71, 74	F <sub>DL_low</sub>	-	F <sub>DL_high</sub>	-50	1	
	E-UTRA band 4, 41, 51, 66, 70, NR Band n77	F <sub>DL_low</sub>	-	F <sub>DL_high</sub>	-50	1	2
	E-UTRA band 26	859	-	869	-27	1	
	E-UTRA band 12, 85	F <sub>DL_low</sub>	-	F <sub>DL_high</sub>	-50	1	3
CA_5-40	E-UTRA Band 1, 3, 5, 7, 8, 28, 31, 34, 38, 42, 43, 45, 65, 73	F <sub>DL_low</sub>	-	F <sub>DL_high</sub>	-50	1	
	E-UTRA band 26	859	-	869	-27	1	
	E-UTRA band 41, 52 NR Band n77, n78, n79	F <sub>DL_low</sub>	-	F <sub>DL_high</sub>	-50	1	2
	Frequency range	1884.5	-	1915.7	-41	0.3	4
CA_7-8	E-UTRA Band 1, 20, 27, 28, 31, 32, 34, 40, 50, 51, 65, 67, 68, 72, 74, 75, 76	F <sub>DL_low</sub>	-	F <sub>DL_high</sub>	-50	1	
	E-UTRA band 3, 7, 22, 42, 43, 52 NR Band n77, n78	F <sub>DL_low</sub>	-	F <sub>DL_high</sub>	-50	1	2
	E-UTRA Band 8	F <sub>DL_low</sub>	-	F <sub>DL_high</sub>	-50	1	3
	Frequency range	2570	-	2575	+1.6	5	3, 13, 14
	Frequency range	2575	-	2595	-15.5	5	3, 13, 14
	Frequency range	2595	-	2620	-40	1	3, 14
CA_7-20	E-UTRA Band 1, 3, 7, 8, 22, 28, 31, 32, 33, 34, 40, 43, 50, 51, 65, 67, 72, 74, 75, 76	F <sub>DL_low</sub>	-	F <sub>DL_high</sub>	-50	1	
	E-UTRA Band 20	F <sub>DL_low</sub>	-	F <sub>DL_high</sub>	-50	1	3
	E-UTRA Band 42, 52 NR Band n77, n78	F <sub>DL_low</sub>	-	F <sub>DL_high</sub>	-50	1	2
	Frequency range	2570	-	2575	+1.6	5	3, 13, 14
	Frequency range	2575	-	2595	-15.5	5	3, 13, 14
	Frequency range	2595	-	2620	-40	1	3, 14
CA_7-26	E-UTRA Band 1, 2, 3, 4, 5, 7, 8, 12, 13, 14, 17, 22, 29, 30, 31, 40, 42, 43, 65, 66, 85	F <sub>DL_low</sub>	-	F <sub>DL_high</sub>	-50	1	
	NR Band n77, n78, n79	F <sub>DL_low</sub>	-	F <sub>DL_high</sub>	-50	1	2
	Frequency range	2570	-	2575	+1.6	5	3, 13, 14
	Frequency range	2575	-	2595	-15.5	5	3, 13, 14

	Frequency range	2595	-	2620	-40	1	3, 14
	Frequency range	703	-	799	-50	1	
	Frequency range	799	-	803	-40	1	3
	Frequency range	945	-	960	-50	1	
	Frequency range	1884.5	-	1915.7	-41	0.3	7
CA_7-28	E-UTRA Band 2, 3, 5, 7, 8, 20, 26, 27, 31, 34, 40, 72 NR Band n79	F <sub>DL,low</sub>	-	F <sub>DL,high</sub>	-50	1	
	E-UTRA Band 1, 4, 22, 32, 42, 43, 50, 51, 52, 65, 66, 74, 75, 76 NR Band n77, n78	F <sub>DL,low</sub>	-	F <sub>DL,high</sub>	-50	1	2
	E-UTRA Band 1	F <sub>DL,low</sub>	-	F <sub>DL,high</sub>	-50	1	5, 6
	Frequency range	758	-	773	-32	1	3
	Frequency range	773	-	803	-50	1	
	Frequency range	2570	-	2575	+1.6	5	3, 13, 14
	Frequency range	2575	-	2595	-15.5	5	3, 13, 14
	Frequency range	2595	-	2620	-40	1	3, 14
CA_8-39	E-UTRA Band 1, 28, 40, 45, 50, 51, 73, 74	F <sub>DL,low</sub>	-	F <sub>DL,high</sub>	-50	1	
	E-UTRA Band 22, 41, 42, 52 NR band n78, n79	F <sub>DL,low</sub>	-	F <sub>DL,high</sub>	-50	1	2
	E-UTRA Band 8	F <sub>DL,low</sub>	-	F <sub>DL,high</sub>	-50	1	3
CA_8-41	E-UTRA Band 1, 28, 34, 39, 40, 45, 50, 51, 65, 73, 74	F <sub>DL,low</sub>	-	F <sub>DL,high</sub>	-50	1	
	E-UTRA band 3, 42, 52 NR Band n77, n78, n79	F <sub>DL,low</sub>	-	F <sub>DL,high</sub>	-50	1	2
	E-UTRA band 11, 21	F <sub>DL,low</sub>	-	F <sub>DL,high</sub>	-50	1	11
	Frequency range	1884.5	-	1915.7	-41	0.3	4, 11
CA_11-18	E-UTRA Band 1, 3, 11, 21, 28, 34, 42, 65 NR Band n79	F <sub>DL,low</sub>	-	F <sub>DL,high</sub>	-50	1	
	NR Band n77, n78	F <sub>DL,low</sub>	-	F <sub>DL,high</sub>	-50	1	2
	Frequency range	860	-	890	-40	1	3
	Frequency range	1884.5	-	1915.7	-41	0.3	4
	Frequency range	2545	-	2575	-50	1	
	Frequency range	2595	-	2645	-50	1	
	Frequency range	945	-	960	-50	1	
CA_11-26	E-UTRA Band 1, 3, 11, 18, 19, 21, 26, 28, 34, 42, 65 NR Band n77, n78, n79	F <sub>DL,low</sub>	-	F <sub>DL,high</sub>	-50	1	
	Frequency range	1884.5	-	1915.7	-41	0.3	4
	Frequency range	2545	-	2575	-50	1	
	Frequency range	2595	-	2645	-50	1	
	Frequency range	945	-	960	-50	1	
CA_13-66	E-UTRA Band 2, 4, 5, 12, 13, 17, 25, 26, 27, 29, 41, 50, 51, 53, 66, 70, 71, 74, 85	F <sub>DL,low</sub>	-	F <sub>DL,high</sub>	-50	1	
	E-UTRA Band 14	F <sub>DL,low</sub>	-	F <sub>DL,high</sub>	-50	1	3
	E-UTRA Band 24, 30, 48, NR Band n77	F <sub>DL,low</sub>	-	F <sub>DL,high</sub>	-50	1	2
	Frequency range	769	-	775	-35	0.00625	3
	Frequency range	799	-	805	-35	0.00625	3, 9
CA_14-30	E-UTRA Band 2, 4, 5, 12, 13, 14, 17, 24, 25, 26, 27, 29, 30, 41, 48, 53, 66, 70, 71, 85	F <sub>DL,low</sub>	-	F <sub>DL,high</sub>	-50	1	
	NR Band n77	F <sub>DL,low</sub>	-	F <sub>DL,high</sub>	-50	1	2
	Frequency range	769	-	775	-35	0.00625	3
	Frequency range	799	-	805	-35	0.00625	3, 9
CA_14-66	E-UTRA Band 2, 4, 5, 12, 13, 14, 17, 24, 25, 26, 27, 29, 30, 41, 53, 66, 70, 71, 85	F <sub>DL,low</sub>	-	F <sub>DL,high</sub>	-50	1	
	E-UTRA Band 48, NR Band n77	F <sub>DL,low</sub>	-	F <sub>DL,high</sub>	-50	1	2
	Frequency range	769	-	775	-35	0.00625	3
	Frequency range	799	-	805	-35	0.00625	3, 9
CA_18-28	E-UTRA Band 11, 21	F <sub>DL,low</sub>	-	F <sub>DL,high</sub>	-50	1	5, 21

	E-UTRA Band 1, 65	F <sub>DL,low</sub>	-	F <sub>DL,high</sub>	-50	1	5, 6
	E-UTRA Band 42, 43 NR Band n77, n78, n79	F <sub>DL,low</sub>	-	F <sub>DL,high</sub>	-50	1	2
	E-UTRA Band 3, 34	F <sub>DL,low</sub>	-	F <sub>DL,high</sub>	-50	1	
	Frequency range	470	-	710	-26.2	6	23
	Frequency range	758	-	773	-32	1	3
	Frequency range	773	-	799	-50	1	
	Frequency range	799	-	803	-40	1	3
	Frequency range	860	-	890	-40	1	
	Frequency range	945	-	960	-50	1	3
	Frequency range	1884.5	-	1915.7	-41	0.3	4
	Frequency range	2545	-	2575	-50	1	
	Frequency range	2595	-	2645	-50	1	
CA_19-21	E-UTRA Band 1, 3, 28, 34, 42, 65 NR Band n79	F <sub>DL,low</sub>	-	F <sub>DL,high</sub>	-50	1	
	NR Band n77, n78,	F <sub>DL,low</sub>	-	F <sub>DL,high</sub>	-50	1	2
	Frequency range	945	-	960	-50	1	
	Frequency range	1884.5	-	1915.7	-41	0.3	4
	Frequency range	2545	-	2575	-50	1	
	Frequency range	2595	-	2645	-50	1	
CA_19-42	E-UTRA Band 1, 3, 11, 21, 28, 34, 65 NR Band n79	F <sub>DL,low</sub>	-	F <sub>DL,high</sub>	-50	1	
	Frequency range	945	-	960	-50	1	
	Frequency range	1884.5	-	1915.7	-41	0.3	4
	Frequency range	2545	-	2575	-50	1	
	Frequency range	2595	-	2645	-50	1	
CA_21-28	E-UTRA Band 1, 42, 65 NR Band n77, n78	F <sub>DL,low</sub>	-	F <sub>DL,high</sub>	-50	1	2
	E-UTRA Band 1	F <sub>DL,low</sub>	-	F <sub>DL,high</sub>	-50	1	5, 6
	E-UTRA Band 3, 18, 19, 34 NR Band n79	F <sub>DL,low</sub>	-	F <sub>DL,high</sub>	-50	1	
	Frequency range	470	-	710	-26.2	6	23
	Frequency range	773	-	803	-50	1	
	Frequency range	945	-	960	-50	1	
	Frequency range	1884.5	-	1915.7	-41	0.3	4, 5
	Frequency range	2545	-	2575	-50	1	
	Frequency range	2595	-	2645	-50	1	
CA_21-42	E-UTRA Band 1, 3, 18, 19, 28, 34, 65 NR Band n79	F <sub>DL,low</sub>	-	F <sub>DL,high</sub>	-50	1	
	Frequency range	945	-	960	-50	1	
	Frequency range	1884.5	-	1915.7	-41	0.3	4
	Frequency range	2545	-	2575	-50	1	
	Frequency range	2595	-	2645	-50	1	
CA_25-26	E-UTRA Band 4, 5, 12, 13, 14, 17, 24, 26, 29, 30, 42, 48, 53, 66, 70, 71, 85 NR Band n77	F <sub>DL,low</sub>	-	F <sub>DL,high</sub>	-50	1	2
CA_25-41	E-UTRA Band 4, 5, 12, 13, 14, 17, 24, 26, 27, 28, 29, 30, 42, 45, 48, 66, 70, 71 E-UTRA Band 2, 25, NR Band n77	F <sub>DL,low</sub>	-	F <sub>DL,high</sub>	-50	1	2
CA_26-46	E-UTRA Band 1, 2, 3, 4, 5, 11, 12, 13, 14, 17, 18, 19, 21, 24, 25, 26, 29, 30, 31, 34, 39, 40, 42, 43, 48, 53, 65, 66, 70, 71, 85 E-UTRA Band 41, NR Band n77	F <sub>DL,low</sub>	-	F <sub>DL,high</sub>	-50	1	1
	Frequency range	703	-	799	-50	1	
	Frequency range	799	-	803	-40	1	2

	Frequency range	945	-	960	-50	1	
	Frequency range	1884.5	-	1915.7	-41	0.3	3
CA_26-48	E-UTRA Band 1, 2, 3, 4, 5, 11, 12, 13, 14, 17, 18, 19, 21, 24, 25, 26, 29, 30, 31, 34, 39, 40, 50, 51, 65, 66, 70, 71, 73, 74	F <sub>DL_low</sub>	-	F <sub>DL_high</sub>	-50	1	
	E-UTRA Band 41	F <sub>DL_low</sub>	-	F <sub>DL_high</sub>	-50	1	1
	Frequency range	703	-	799	-50	1	
	Frequency range	799	-	803	-40	1	2
	Frequency range	945	-	960	-50	1	
	Frequency range	1884.5	-	1915.7	-41	0.3	3
CA_28-41	E-UTRA Band E-UTRA Band 1, 4, 22, 42, 43, 52, 65, 66 NR Band n77, n78, n79	F <sub>DL_low</sub>	-	F <sub>DL_high</sub>	-50	1	2
	E-UTRA Band 1	F <sub>DL_low</sub>	-	F <sub>DL_high</sub>	-50	1	5, 6
	E-UTRA band 2, 3, 5, 8, 20, 25, 26, 27, 31, 32, 33, 34, 40, 45, 48	F <sub>DL_low</sub>	-	F <sub>DL_high</sub>	-50	1	
	E-UTRA band 11, 21	F <sub>DL_low</sub>	-	F <sub>DL_high</sub>	-50	1	5, 18, 21
	E-UTRA band 9, 18, 19	F <sub>DL_low</sub>	-	F <sub>DL_high</sub>	-50	1	5, 18
	Frequency range	470	-	694	-42	8	3, 22
	Frequency range	470	-	710	-26.2	6	23
	Frequency range	662	-	694	-26.2	6	3
	Frequency range	758	-	773	-32	1	3
	Frequency range	773	-	803	-50	1	
	Frequency range	1884.5	-	1915.7	-41	0.3	4, 5, 18
	CA_28-42	E-UTRA Band 1, 4, 32, 50, 51, 66, 65, 74, 75, 76	F <sub>DL_low</sub>	-	F <sub>DL_high</sub>	-50	1
E-UTRA Band 1		F <sub>DL_low</sub>	-	F <sub>DL_high</sub>	-50	1	5, 6
E-UTRA Band 2, 3, 5, 7, 8, 18, 19, 20, 25, 26, 27, 31, 34, 38, 40, 41, 72, 73 NR Band n79		F <sub>DL_low</sub>	-	F <sub>DL_high</sub>	-50	1	
E-UTRA Band 11, 21		F <sub>DL_low</sub>	-	F <sub>DL_high</sub>	-50	1	5, 21
Frequency range		470	-	710	-26.2	6	23
Frequency range		758	-	773	-32	1	3
Frequency range		773	-	803	-50	1	
Frequency range		1884.5	-	1915.7	-41	0.3	4, 5
CA_39-41	E-UTRA Band 1, 8, 26, 28, 34, 40, 42, 44, 50, 51, 52, 73, 74	F <sub>DL_low</sub>	-	F <sub>DL_high</sub>	-50	1	
	NR Band n77, n78, n79	F <sub>DL_low</sub>	-	F <sub>DL_high</sub>	-50	1	2
	Frequency range	1805	-	1855	-40	1	20
	Frequency range	1855	-	1880	-15.5	5	3, 13, 20
CA_40-42	E-UTRA Band 1, 2, 3, 4, 5, 7, 8, 11, 12, 13, 14, 17, 18, 19, 20, 21, 24, 25, 26, 27, 28, 29, 31, 32, 33, 34, 38, 39, 41, 44, 45, 50, 51, 65, 66, 67, 68, 69, 70, 72, 73, 74, 75, 76	F <sub>DL_low</sub>	-	F <sub>DL_high</sub>	-50	1	
	Frequency range	1884.5	-	1915.7	-41	0.3	8
CA_41-42	E-UTRA Band 1, 3, 5, 8, 26, 28, 33, 34, 39, 40, 44, 45, 50, 51, 65, 73, 74	F <sub>DL_low</sub>	-	F <sub>DL_high</sub>	-50	1	
	E-UTRA Band 9, 11, 18, 19, 21	F <sub>DL_low</sub>	-	F <sub>DL_high</sub>	-50	1	18
	NR Band n79	F <sub>DL_low</sub>	-	F <sub>DL_high</sub>	-50	1	2
	Frequency range	1884.5	-	1915.7	-41	0.3	4, 18

- NOTE 1:  $F_{DL\_low}$  and  $F_{DL\_high}$  refer to each E-UTRA frequency band specified in Table 5.5-1
- NOTE 2: As exceptions, measurements with a level up to the applicable requirements defined in Table 6.6.3.1-2 are permitted for each assigned E-UTRA carrier used in the measurement due to 2<sup>nd</sup>, 3<sup>rd</sup>, 4<sup>th</sup> [or 5<sup>th</sup>] harmonic spurious emissions. In case the exceptions are allowed due to spreading of the harmonic emission the exception is also allowed for the first 1 MHz frequency range immediately outside the harmonic emission on both sides of the harmonic emission. This results in an overall exception interval centred at the harmonic emission of  $(2\text{MHz} + N \times L_{CRB} \times 180\text{kHz})$ , where N is 2, 3 or 4 for the 2<sup>nd</sup>, 3<sup>rd</sup> or 4<sup>th</sup> harmonic respectively. The exception is allowed if the measurement bandwidth (MBW) totally or partially overlaps the overall exception interval.
- NOTE 3: These requirements also apply for the frequency ranges that are less than  $F_{OOB}$  (MHz) in Table 6.6.3.1-1 and Table 6.6.3.1A-1 from the edge of the aggregated channel bandwidth.
- NOTE 4: Applicable when co-existence with PHS system operating in 1884.5 - 1915.7MHz.
- NOTE 5: Applicable when the assigned E-UTRA carrier is confined within 718 MHz and 748 MHz and when the channel bandwidth used is 5 or 10 MHz.
- NOTE 6: As exceptions, measurements with a level up to the applicable requirement of -36 dBm/MHz is permitted for each assigned E-UTRA carrier used in the measurement due to 3<sup>rd</sup> harmonic spurious emissions. An exception is allowed if there is at least one individual RB within the transmission bandwidth (see Figure 5.6-1) for which the 3<sup>rd</sup> harmonic totally or partially overlaps the measurement bandwidth (MBW).
- NOTE 7: Void
- NOTE 8: Void
- NOTE 9: Void
- NOTE 10: Void
- NOTE 11: This requirement is applicable only for the following cases:
- for carriers of 5 MHz channel bandwidth when carrier centre frequency ( $F_c$ ) is within the range  $902.5 \text{ MHz} \leq F_c < 907.5 \text{ MHz}$  with an uplink transmission bandwidth less than or equal to 20 RB
  - for carriers of 5 MHz channel bandwidth when carrier centre frequency ( $F_c$ ) is within the range  $907.5 \text{ MHz} \leq F_c \leq 912.5 \text{ MHz}$  without any restriction on uplink transmission bandwidth.
  - for carriers of 10 MHz channel bandwidth when carrier centre frequency ( $F_c$ ) is  $F_c = 910 \text{ MHz}$  with an uplink transmission bandwidth less than or equal to 32 RB with  $RB_{start} > 3$ .
- NOTE 12: This requirement is applicable for any channel bandwidths within the range 1920 - 1980 MHz with the following restriction: for carriers of 15 MHz bandwidth when carrier centre frequency is within the range 1927.5 - 1929.5 MHz and for carriers of 20 MHz bandwidth when carrier centre frequency is within the range 1930 - 1938 MHz the requirement is applicable only for an uplink transmission bandwidth less than or equal to 54 RB.
- NOTE 13: For these adjacent bands, the emission limit could imply risk of harmful interference to UE(s) operating in the protected operating band.
- NOTE 14: This requirement is applicable for any channel bandwidths within the range 2500 - 2570 MHz with the following restriction: for carriers of 15 MHz bandwidth when carrier centre frequency is within the range 2560.5 - 2562.5 MHz and for carriers of 20 MHz bandwidth when carrier centre frequency is within the range 2552 - 2560 MHz the requirement is applicable only for an uplink transmission bandwidth less than or equal to 54 RB.
- NOTE 15: Void
- NOTE 16: Void
- NOTE 17: This requirement is applicable only when Band 3 transmission frequency is less than or equal to 1765 MHz.
- NOTE 18: This requirement applies when the E-UTRA carrier is confined within 2545-2575MHz or 2595-2645MHz and the channel bandwidth is 10 or 20 MHz
- NOTE 19: Void
- NOTE 20: This requirement is only applicable for carriers with bandwidth confined within 1885-1920 MHz (requirement for carriers with at least 1RB confined within 1880 - 1885 MHz is not specified). This requirement applies for an uplink transmission bandwidth less than or equal to 54 RB for carriers of 15 MHz bandwidth when carrier center frequency is within the range 1892.5 - 1894.5 MHz and for carriers of 20 MHz bandwidth when carrier center frequency is within the range 1895 - 1903 MHz.
- NOTE 21: As exceptions, measurements with a level up to the applicable requirement of -38 dBm/MHz is permitted for each assigned E-UTRA carrier used in the measurement due to 2<sup>nd</sup> harmonic spurious emissions. An exception is allowed if there is at least one individual RB within the transmission bandwidth (see Figure 5.6-1) for which the 2<sup>nd</sup> harmonic totally or partially overlaps the measurement bandwidth (MBW).
- NOTE 22: This requirement is applicable in the case of a 10 MHz E-UTRA carrier confined within 703 MHz and 733 MHz, otherwise the requirement of -25 dBm with a measurement bandwidth of 8 MHz applies.
- NOTE 23: This requirement is applicable for 5 and 10 MHz E-UTRA channel bandwidth allocated within 718-728MHz. For carriers of 10 MHz bandwidth, this requirement applies for an uplink transmission bandwidth less than or equal to 30 RB with  $RB_{start} > 1$  and  $RB_{start} < 48$ .
- NOTE 24: Void
- NOTE 25: Void



**Table 6.6.3.2A-1: Requirements for intraband carrier aggregation**

E-UTRA CA Configuration	Spurious emission						
	Protected band	Frequency range (MHz)		Maximum Level (dBm)	MBW (MHz)	NOTE	
CA_1	E-UTRA Band 1, 7, 8, 11, 18, 19, 20, 21, 22, 26, 27, 28, 31, 32, 38, 40, 41, 42, 43, 44, 50, 51, 52, 65, 67, 72, 73, 74, 75, 76 NR Band n78, n79	F <sub>DL_low</sub>	-	F <sub>DL_high</sub>	-50	1	
	E-UTRA Band 3	F <sub>DL_low</sub>	-	F <sub>DL_high</sub>	-50	1	10
	NR Band n77	F <sub>DL_low</sub>	-	F <sub>DL_high</sub>	-50	1	2
CA_3	E-UTRA Band 1, 7, 8, 20, 26, 27, 28, 31, 32, 33, 34, 38, 41, 43, 44, 50, 51, 65, 67, 72, 73, 74, 75, 76 NR Band n79	F <sub>DL_low</sub>	-	F <sub>DL_high</sub>	-50	1	
	E-UTRA Band 3	F <sub>DL_low</sub>	-	F <sub>DL_high</sub>	-50	1	10
	E-UTRA Band 22, 42, 52 NR Band n77, n78	F <sub>DL_low</sub>	-	F <sub>DL_high</sub>	-50	1	2
CA_5	E-UTRA Band 1, 2, 3, 4, 5, 7, 8, 12, 13, 14, 17, 24, 25, 28, 29, 30, 31, 34, 38, 40, 42, 43, 45, 48, 53, 65, 66, 70, 71, 85	F <sub>DL_low</sub>	-	F <sub>DL_high</sub>	-50	1	
	E-UTRA band 52 NR Band n77, n78, n79	F <sub>DL_low</sub>	-	F <sub>DL_high</sub>	-50	1	2
CA_7	E-UTRA Band 1, 3, 7, 8, 20, 22, 27, 28, 29, 30, 31, 32, 33, 34, 40, 42, 43, 50, 51, 52, 65, 67, 72, 74, 75, 76 NR Band n77, n78	F <sub>DL_low</sub>	-	F <sub>DL_high</sub>	-50	1	
CA_8	E-UTRA Band 1, 20, 28, 31, 32, 33, 34, 38, 39, 40, 50, 51, 72, 73, 74, 75, 76	F <sub>DL_low</sub>	-	F <sub>DL_high</sub>	-50	1	
	E-UTRA band 3	F <sub>DL_low</sub>	-	F <sub>DL_high</sub>	-50	1	2
	E-UTRA band 7	F <sub>DL_low</sub>	-	F <sub>DL_high</sub>	-50	1	2
	E-UTRA Band 8	F <sub>DL_low</sub>	-	F <sub>DL_high</sub>	-50	1	10
	E-UTRA Band 22, 41, 42, 43, 52 NR Band n77, n78, n79	F <sub>DL_low</sub>	-	F <sub>DL_high</sub>	-50	1	2
CA_38	E-UTRA Band 1, 3, 8, 20, 22, 27, 28, 29, 30, 31, 32, 33, 34, 40, 42, 43, 50, 51, 52, 65, 67, 72, 74, 75, 76	F <sub>DL_low</sub>	-	F <sub>DL_high</sub>	-50	1	
CA_39	E-UTRA Band 22, 34, 40, 41, 42, 44, 50, 51, 52, 73, 74 NR Band n79	F <sub>DL_low</sub>	-	F <sub>DL_high</sub>	-50	1	
	NR Band n77, n78	F <sub>DL_low</sub>	-	F <sub>DL_high</sub>	-50	1	2
CA_40	E-UTRA Band 1, 3, 7, 8, 20, 22, 26, 27, 31, 32, 33, 34, 38, 39, 41, 42, 43, 44, 50, 51, 52, 65, 67, 72, 73, 74, 75, 76 NR Band n77, n78	F <sub>DL_low</sub>	-	F <sub>DL_high</sub>	-50	1	
	NR Band n79	F <sub>DL_low</sub>	-	F <sub>DL_high</sub>	-50	1	2
CA_41	E-UTRA Band 1, 2, 3, 4, 5, 8, 12, 13, 14, 17, 24, 25, 26, 27, 28, 29, 30, 34, 39, 40, 42, 44, 50, 51, 52, 65, 66, 70, 71, 73, 74, 85 NR Band n77, n78	F <sub>DL_low</sub>	-	F <sub>DL_high</sub>	-50	1	
	NR Band n79	F <sub>DL_low</sub>	-	F <sub>DL_high</sub>	-50	1	2
CA_42	E-UTRA Band 1, 2, 3, 4, 5, 7, 8, 11, 18, 19, 20, 21, 25, 26, 27, 28, 31, 32, 33, 34, 38, 40, 41, 44, 50, 51, 65, 66, 67, 72, 73, 74, 75, 76 NR Band n79	F <sub>DL_low</sub>	-	F <sub>DL_high</sub>	-50	1	
	Frequency range	1884.5	-	1915.7	-41	0.3	
CA_48	E-UTRA Band 2, 4, 5, 12, 13, 14, 17, 24, 25, 26, 29, 30, 41, 50, 51, 66, 70, 71, 74, 85	F <sub>DL_low</sub>	-	F <sub>DL_high</sub>	-50	1	
CA_66	E-UTRA Band 2, 4, 5, 7, 12, 13, 14, 17, 24, 25, 26, 27, 28, 29, 30, 38, 41, 43, 50, 51, 66, 70, 71, 74, 85	F <sub>DL_low</sub>	-	F <sub>DL_high</sub>	-50	1	
	E-UTRA Band 42, 48, 49, 52, NR Band n77	F <sub>DL_low</sub>	-	F <sub>DL_high</sub>	-50	1	2

NOTE 1:	FDL_low and FDL_high refer to each E-UTRA frequency band specified in Table 5.5-1
NOTE 2:	As exceptions, measurements with a level up to the applicable requirements defined in Table 6.6.3.1-2 are permitted for each assigned E-UTRA carrier used in the measurement due to 2 <sup>nd</sup> , 3 <sup>rd</sup> , 4 <sup>th</sup> [or 5 <sup>th</sup> ] harmonic spurious emissions. Due to spreading of the harmonic emission the exception is also allowed for the first 1 MHz frequency range immediately outside the harmonic emission on both sides of the harmonic emission. This results in an overall exception interval centred at the harmonic emission of (2MHz + N x L <sub>CRB</sub> x 180kHz), where N is 2, 3, 4, [5] for the 2 <sup>nd</sup> , 3 <sup>rd</sup> , 4 <sup>th</sup> [or 5 <sup>th</sup> ] harmonic respectively. The exception is allowed if the measurement bandwidth (MBW) totally or partially overlaps the overall exception interval
NOTE 3:	To meet these requirements some restriction will be needed for either the operating band or protected band
NOTE 4:	N/A
NOTE 5:	N/A
NOTE 6:	N/A
NOTE 7:	N/A
NOTE 8:	N/A
NOTE 9:	N/A
NOTE 10:	The requirement also applies for the frequency ranges that are less than F <sub>OOB</sub> (MHz) in Table 6.6.3.1-1 and Table 6.6.3.1A-1 from the edge of the aggregated channel bandwidth.
NOTE 11:	N/A
NOTE 12:	N/A
NOTE 13:	N/A
NOTE 14:	N/A

Table 6.6.3.2A-2: Requirements for intraband non-contiguous CA

E-UTRA CA Configuration	Spurious emission					NOTE	
	Protected band	Frequency range (MHz)		Maximum Level (dBm)	MBW (MHz)		
CA_4-4	E-UTRA Band 2, 4, 5, 10, 12, 13, 14, 17, 22, 24, 25, 26, 27, 28, 29, 30, 41, 43, 50, 51, 53, 66, 70, 71, 74, 85	F <sub>DL_low</sub>	-	F <sub>DL_high</sub>	-50	1	
	E-UTRA Band 42, NR Band n7	F <sub>DL_low</sub>	-	F <sub>DL_high</sub>	-50	1	2
NOTE 1:	F <sub>DL_low</sub> and F <sub>DL_high</sub> refer to each E-UTRA frequency band specified in Table 5.5-1						
NOTE 2:	As exceptions, measurements with a level up to the applicable requirements defined in Table 6.6.3.1-2 are permitted for each assigned E-UTRA carrier used in the measurement due to 2 <sup>nd</sup> or 3 <sup>rd</sup> harmonic spurious emissions. Due to spreading of the harmonic emission the exception is also allowed for the first 1 MHz frequency range immediately outside the harmonic emission on both sides of the harmonic emission. This results in an overall exception interval centred at the harmonic emission of (2MHz + N x L <sub>CRB</sub> x 180kHz), where N is 2 or 3 for the 2 <sup>nd</sup> or 3 <sup>rd</sup> harmonic respectively. The exception is allowed if the measurement bandwidth (MBW) totally or partially overlaps the overall exception interval.						

### 6.6.3.3 Additional spurious emissions

These requirements are specified in terms of an additional spectrum emission requirement. Additional spurious emission requirements are signalled by the network to indicate that the UE shall meet an additional requirement for a specific deployment scenario as part of the cell handover/broadcast message.

NOTE: For measurement conditions at the edge of each frequency range, the lowest frequency of the measurement position in each frequency range should be set at the lowest boundary of the frequency range plus MBW/2. The highest frequency of the measurement position in each frequency range should be set at the highest boundary of the frequency range minus MBW/2. MBW denotes the measurement bandwidth defined for the protected band.

#### 6.6.3.3.1 Minimum requirement (network signalled value "NS\_05")

When "NS\_05" is indicated in the cell, the power of any UE emission shall not exceed the levels specified in Table 6.6.3.3.1-1. This requirement also applies for the frequency ranges that are less than F<sub>OOB</sub> (MHz) in Table 6.6.3.1-1 from the edge of the channel bandwidth.

**Table 6.6.3.3.1-1: Additional requirements (PHS)**

Frequency band (MHz)	Channel bandwidth / Spectrum emission limit (dBm)				Measurement bandwidth	NOTE
	5 MHz	10 MHz	15 MHz	20 MHz		
$1884.5 \leq f \leq 1915.7$	-41	-41	-41	-41	300 KHz	1

**Table 6.6.3.3.1-2: Void****6.6.3.3.2 Minimum requirement (network signalled value "NS\_07")**

When "NS\_07" is indicated in the cell, the power of any UE emission shall not exceed the levels specified in Table 6.6.3.3.2-1. This requirement also applies for the frequency ranges that are less than F<sub>OOB</sub> (MHz) in Table 6.6.3.1-1 from the edge of the channel bandwidth.

**Table 6.6.3.3.2-1: Additional requirements**

Frequency band (MHz)	Channel bandwidth / Spectrum emission limit (dBm)		Measurement bandwidth
	10 MHz		
$769 \leq f \leq 775$	-57		6.25 kHz
NOTE: The emissions measurement shall be sufficiently power averaged to ensure standard standard deviation < 0.5 dB.			

**6.6.3.3.3 Minimum requirement (network signalled value "NS\_08")**

When "NS\_08" is indicated in the cell, the power of any UE emission shall not exceed the levels specified in Table 6.6.3.3.3-1. This requirement also applies for the frequency ranges that are less than F<sub>OOB</sub> (MHz) in Table 6.6.3.1-1 from the edge of the channel bandwidth.

**Table 6.6.3.3.3-1: Additional requirement**

Frequency band (MHz)	Channel bandwidth / Spectrum emission limit (dBm)			Measurement bandwidth
	5MHz	10MHz	15MHz	
$860 \leq f \leq 890$	-40	-40	-40	1 MHz

**6.6.3.3.4 Minimum requirement (network signalled value "NS\_09")**

When "NS\_09" is indicated in the cell, the power of any UE emission shall not exceed the levels specified in Table 6.6.3.3.4-1. This requirement also applies for the frequency ranges that are less than F<sub>OOB</sub> (MHz) in Table 6.6.3.1-1 from the edge of the channel bandwidth.

**Table 6.6.3.3.4-1: Additional requirement**

Frequency band (MHz)	Channel bandwidth / Spectrum emission limit (dBm)			Measurement bandwidth
	5MHz	10MHz	15MHz	
$1475.9 \leq f \leq 1510.9$	-35	-35	-35	1 MHz

NOTE 1: Void.

NOTE 2: To improve measurement accuracy, A-MPR values for NS\_09 specified in Table 6.2.4-1 in subclause 6.2.4 are derived based on 100 kHz RBW.

### 6.6.3.3.5 Minimum requirement (network signalled value "NS\_12")

When "NS 12" is indicated in the cell, the power of any UE emission shall not exceed the levels specified in Table 6.6.3.3.5-1. This requirement also applies for the frequency ranges that are less than  $F_{OOB}$  (MHz) in Table 6.6.3.1-1 from the edge of the channel bandwidth.

**Table 6.6.3.3.5-1: Additional requirements**

Frequency band (MHz)	Channel bandwidth / Spectrum emission limit (dBm)	Measurement bandwidth
	1.4 MHz, 3 MHz, 5 MHz, 10 MHz, 15 MHz	
$806 \leq f \leq 813.5$	-42	6.25 kHz
NOTE 1: The requirement applies for E-UTRA carriers with lower channel edge at or above 814.2 MHz. NOTE 2: The emissions measurement shall be sufficiently power averaged to ensure a standard deviation < 0.5 dB.		

### 6.6.3.3.6 Minimum requirement (network signalled value "NS\_13")

When "NS 13" is indicated in the cell, the power of any UE emission shall not exceed the levels specified in Table 6.6.3.3.6-1. This requirement also applies for the frequency ranges that are less than  $F_{OOB}$  (MHz) in Table 6.6.3.1-1 from the edge of the channel bandwidth.

**Table 6.6.3.3.6-1: Additional requirements**

Frequency band (MHz)	Channel bandwidth / Spectrum emission limit (dBm)	Measurement bandwidth
	1.4, 3, 5 MHz	
$806 \leq f \leq 816$	-42	6.25 kHz
NOTE 1: The requirement applies for E-UTRA carriers with lower channel edge at or above 819 MHz. NOTE 2: The emissions measurement shall be sufficiently power averaged to ensure a standard deviation < 0.5 dB.		

### 6.6.3.3.7 Minimum requirement (network signalled value "NS\_14")

When "NS 14" is indicated in the cell, the power of any UE emission shall not exceed the levels specified in Table 6.6.3.3.7-1. This requirement also applies for the frequency ranges that are less than  $F_{OOB}$  (MHz) in Table 6.6.3.1-1 from the edge of the channel bandwidth.

**Table 6.6.3.3.7-1: Additional requirements**

Frequency band (MHz)	Channel bandwidth / Spectrum emission limit (dBm)	Measurement bandwidth
	10 MHz, 15 MHz	
$806 \leq f \leq 816$	-42	6.25 kHz
NOTE 1: The requirement applies for E-UTRA carriers with lower channel edge at or above 824 MHz. NOTE 2: The emissions measurement shall be sufficiently power averaged to ensure a standard deviation < 0.5 dB.		

### 6.6.3.3.8 Minimum requirement (network signalled value "NS\_15")

When "NS 15" is indicated in the cell, the power of any UE emission shall not exceed the levels specified in Table 6.6.3.3.8-1. This requirement also applies for the frequency ranges that are less than  $F_{OOB}$  (MHz) in Table 6.6.3.1-1 from the edge of the channel bandwidth.

**Table 6.6.3.3.8-1: Additional requirements**

Frequency band (MHz)	Channel bandwidth / Spectrum emission limit (dBm)	Measurement bandwidth
	1.4 MHz, 3 MHz, 5 MHz, 10 MHz, 15 MHz	
$851 \leq f \leq 859$	-53	6.25 kHz
NOTE 1: The emissions measurement shall be sufficiently power averaged to ensure a standard deviation < 0.5 dB.		

#### 6.6.3.3.9 Minimum requirement (network signalled value "NS\_16")

When "NS\_16" is indicated in the cell, the power of any UE emission shall not exceed the levels specified in Table 6.6.3.3.9-1. This requirement also applies for the frequency ranges that are less than  $F_{OOB}$  (MHz) in Table 6.6.3.1-1 from the edge of the channel bandwidth.

**Table 6.6.3.3.9-1: Additional requirements**

Frequency band (MHz)	Channel bandwidth / Spectrum emission limit (dBm)	Measurement bandwidth	NOTE
	1.4, 3, 5, 10 MHz		
$790 \leq f \leq 803$	-32	1 MHz	

#### 6.6.3.3.10 Minimum requirement (network signalled value "NS\_17")

When "NS\_17" is indicated in the cell, the power of any UE emission shall not exceed the levels specified in Table 6.6.3.3.10-1. This requirement also applies for the frequency ranges that are less than  $F_{OOB}$  (MHz) in Table 6.6.3.1-1 from the edge of the channel bandwidth.

**Table 6.6.3.3.10-1: Additional requirements**

Frequency band (MHz)	Channel bandwidth / Spectrum emission limit (dBm)	Measurement bandwidth	NOTE
	5, 10 MHz		
$470 \leq f \leq 710$	-26.2	6 MHz	1
NOTE 1: Applicable when the assigned E-UTRA carrier is confined within 718 MHz and 748 MHz and when the channel bandwidth used is 5 or 10 MHz.			

#### 6.6.3.3.11 Minimum requirement (network signalled value "NS\_18")

When "NS\_18" is indicated in the cell, the power of any UE emission shall not exceed the levels specified in Table 6.6.3.3.11-1. This requirement also applies for the frequency ranges that are less than  $F_{OOB}$  (MHz) in Table 6.6.3.1-1 from the edge of the channel bandwidth.

**Table 6.6.3.3.11-1: Additional requirements**

Frequency band (MHz)	Channel bandwidth / Spectrum emission limit (dBm)	Measurement bandwidth	NOTE
	5, 10, 15, 20 MHz		
692-698	-26.2	6 MHz	

#### 6.6.3.3.12 Minimum requirement (network signalled value "NS\_19")

When "NS\_19" is indicated in the cell, the power of any UE emission shall not exceed the levels specified in Table 6.6.3.3.12-1. This requirement also applies for the frequency ranges that are less than  $F_{OOB}$  (MHz) in Table 6.6.3.1-1 from the edge of the channel bandwidth.

**Table 6.6.3.3.12-1: Additional requirements**

Frequency band (MHz)	Channel bandwidth / Spectrum emission limit (dBm)	Measurement bandwidth	NOTE
	3, 5, 10, 15, 20 MHz		
$662 \leq f \leq 694$	-25	8 MHz	

#### 6.6.3.3.13 Minimum requirement (network signalled value “NS\_11”)

When “NS\_11” is indicated in the cell, the power of any UE emission shall not exceed the levels specified in Table 6.6.3.3.13-1. These requirements also apply for the frequency ranges that are less than  $F_{OOB}$  (MHz) in Table 6.6.3.1-1 and Table 6.6.3.1A-1 from the edge of the channel bandwidth.

**Table 6.6.3.3.13-1: Additional requirements**

Frequency band (MHz)	Channel bandwidth / Spectrum emission limit (dBm)	Measurement bandwidth
	1.4, 3, 5, 10, 15, 20 MHz	
E-UTRA Band 2	-50	1 MHz
$1998 \leq f \leq 1999$	-21	1 MHz
$1997 \leq f < 1998$	-27	1 MHz
$1996 \leq f < 1997$	-32	1 MHz
$1995 \leq f < 1996$	-37	1 MHz
$1990 \leq f < 1995$	-40	1 MHz

#### 6.6.3.3.14 Minimum requirement (network signalled value “NS\_20”)

When “NS\_20” is indicated in the cell, the power of any UE emission shall not exceed the levels specified in Table 6.6.3.3.14-1. These requirements also apply for the frequency ranges that are less than  $F_{OOB}$  (MHz) in Table 6.6.3.1-1 and Table 6.6.3.1A-1 from the edge of the channel bandwidth.

**Table 6.6.3.3.14-1: Additional requirements**

Frequency band (MHz)	Channel bandwidth / Spectrum emission limit (dBm)	Measurement bandwidth
	5, 10, 15, 20 MHz	
$1990 \leq f < 1999$	-40	1 MHz
$1999 \leq f \leq 2000$	-40	NOTE 1
NOTE 1: The measurement bandwidth is 1% of the applicable E-UTRA channel bandwidth.		

#### 6.6.3.3.15 Minimum requirement (network signalled value “NS\_21”)

When “NS\_21” is indicated in the cell, the power of any UE emission shall not exceed the levels specified in Table 6.6.3.3.15-1. These requirements also apply for the frequency ranges that are less than  $F_{OOB}$  (MHz) in Table 6.6.3.1-1 and Table 6.6.3.1A-1 from the edge of the channel bandwidth.

Table 6.6.3.3.15-1: Additional requirements

Frequency band (MHz)	Channel bandwidth / Spectrum emission limit (dBm)	Measurement bandwidth
	5, 10 MHz	
$2200 \leq f < 2288$	-40	1 MHz
$2288 \leq f < 2292$	-37	1 MHz
$2292 \leq f < 2296$	-31	1 MHz
$2296 \leq f < 2300$	-25	1 MHz
$2320 \leq f < 2324$	-25	1 MHz
$2324 \leq f < 2328$	-31	1 MHz
$2328 \leq f < 2332$	-37	1 MHz
$2332 \leq f \leq 2395$	-40	1 MHz

## 6.6.3.3.16 Minimum requirement (network signalled value "NS\_22")

When "NS 22" is indicated in the cell, the power of any UE emission shall not exceed the levels specified in Table 6.6.3.3.16-1. This requirement also applies for the frequency ranges that are less than  $F_{OoB}$  (MHz) in Table 6.6.3.1-1 from the edge of the channel bandwidth.

Table 6.6.3.3.16-1: Additional requirement

Frequency band (MHz)	Channel bandwidth / Spectrum emission limit (dBm)	MBW
	5, 10, 15, 20 MHz	
$3400 \leq f \leq 3800$	-23 (NOTE 1, NOTE 3)	5 MHz
	-40 (NOTE 2)	1 MHz

NOTE 1: This requirement applies within an offset between 5 MHz and 25 MHz from the lower and from the upper edge of the channel bandwidth, whenever these frequencies overlap with the specified frequency band.

NOTE 2: This requirement applies from 3400 MHz to 25 MHz below the lower E-UTRA channel edge and from 25 MHz above the upper E-UTRA channel edge to 3800 MHz.

NOTE 3: This emission limit might imply risk of harmful interference to UE(s) operating in the protected operating band

## 6.6.3.3.17 Minimum requirement (network signalled value "NS\_23")

When "NS 23" is indicated in the cell, the power of any UE emission shall not exceed the levels specified in Table 6.6.3.3.17-1. This requirement also applies for the frequency ranges that are less than  $F_{OoB}$  (MHz) in Table 6.6.3.1-1 from the edge of the channel bandwidth.



Table 6.6.3.3.17-1: Additional requirement

Frequency band (MHz)	Channel bandwidth / Spectrum emission limit (dBm)	MBW
	5, 10, 15, 20 MHz	
3400 ≤ f ≤ 3800	-23 (NOTE 1, NOTE 4)	5 MHz
	-40 (NOTE 2)	1 MHz
NOTE 1: This requirement applies within an offset between 5 MHz + F <sub>offset_NS_23</sub> and 25 MHz + F <sub>offset_NS_23</sub> from the lower and from the upper edges of the channel bandwidth, whenever these frequencies overlap with the specified frequency band.		
NOTE 2: This requirement applies from 3400 MHz to 25 MHz + F <sub>offset_NS_23</sub> below the lower E-UTRA channel edge and from 25 MHz + F <sub>offset_NS_23</sub> above the upper E-UTRA channel edge to 3800 MHz.		
NOTE 3: F <sub>offset_NS_23</sub> is: 0 MHz for 5 MHz channel BW, 5 MHz for 10 MHz channel BW, 9 MHz for 15 MHz channel BW and 12 MHz for 20 MHz channel BW.		
NOTE 4: This emission limit might imply risk of harmful interference to UE(s) operating in the protected operating band		

6.6.3.3.18 Void

Table 6.6.3.3.18-1: Void

6.6.3.3.19 Minimum requirement (network signalled value "NS\_04")

When "NS\_04" is indicated in the cell, the power of any UE emission shall not exceed the levels specified in Table 6.6.3.3.19-1. This requirement also applies for the frequency ranges that are less than F<sub>00B</sub> (MHz) in Table 6.6.3.1-1 from the edge of the channel bandwidth.

Table 6.6.3.3.19-1: Additional requirements

Frequency band	Channel bandwidth / Spectrum emission limit (dBm)	Measurement bandwidth
	5, 10, 15, 20 MHz	
2490.5 MHz ≤ f < 2495 MHz	-13	1 MHz
9 kHz < f < 2490.5 MHz	-25	1 MHz

6.6.3.3.20 Minimum requirement (network signalled value "NS\_24")

When "NS\_24" is indicated in the cell, the power of any UE emission shall not exceed the levels specified in Table 6.6.3.3.20-1. This requirement also applies for the frequency ranges that are less than F<sub>00B</sub> (MHz) in Table 6.6.3.1-1 from the edge of the channel bandwidth.

Table 6.6.3.3.20-1: Additional requirements

Frequency band (MHz)	Channel bandwidth / Spectrum emission limit (dBm)	Measurement bandwidth
	5 MHz, 10 MHz, 15 MHz, 20 MHz	
Band 34	-50	MHz
NOTE 1: This requirement applies at a frequency offset equal or larger than 5 MHz from the upper edge of the channel bandwidth, whenever these frequencies overlap with the specified frequency band.		

## 6.6.3.3.21 Minimum requirement (network signalled value "NS\_25")

When "NS\_25" is indicated in the cell, the power of any UE emission shall not exceed the levels specified in Table 6.6.3.3.21-1. This requirement also applies for the frequency ranges that are less than  $F_{OoB}$  (MHz) in Table 6.6.3.1-1 from the edge of the channel bandwidth.

Table 6.6.3.3.21-1: Additional requirements

Frequency band (MHz)	Channel bandwidth / Spectrum emission limit (dBm)	Measurement bandwidth
	5 MHz, 10 MHz, 15 MHz, 20 MHz	
Band 34	-40	MHz
NOTE 1: This requirement applies at a frequency offset equal or larger than 5 MHz from the upper edge of the channel bandwidth, whenever these frequencies overlap with the specified frequency band.		

## 6.6.3.3.22 Minimum requirement (network signalled value "NS\_26")

When "NS\_26" is indicated in the cell, the power of any UE emission shall not exceed the levels specified in Table 6.6.3.3.22-1. This requirement also applies for the frequency ranges that are less than  $F_{OoB}$  (MHz) in Table 6.6.3.1-1 from the edge of the channel bandwidth.

Table 6.6.3.3.22-1: Additional requirements

Frequency band (MHz)	Channel bandwidth / Spectrum emission limit (dBm)	Measurement bandwidth
	5 MHz, 10 MHz, 15 MHz	
$686 \leq f \leq 694$	-25	8MHz

## 6.6.3.3.23 Minimum requirement (network signalled value "NS\_27" and "NS\_43")

When "NS\_27" or "NS\_43" is indicated in the cell, the power of any UE emission shall not exceed the levels specified in Table 6.6.3.3.23-1. This requirement also applies for the frequency ranges that are less than  $F_{OoB}$  (MHz) in Table 6.6.3.1-1 from the edge of the channel bandwidth.

Table 6.6.3.3.23-1: Additional requirements

Frequency band	Channel bandwidth / Spectrum emission limit (dBm)	Measurement bandwidth
	5, 10, 15, 20 MHz	
$9 \text{ kHz} \leq f \leq 3530 \text{ MHz}$	-40	1 MHz
$3720 \text{ MHz} \leq f \leq 5^{\text{th}} \text{ harmonic of the upper frequency edge of the UL operating band}$		

## 6.6.3.3.24 Minimum requirement (network signalled value "NS\_28")

When "NS\_28" is indicated in the cell, the power of any UE emission for E-UTRA channels assigned within 5150-5350 MHz and 5470-5725 MHz shall not exceed the levels specified in Table 6.6.3.3.24-1. This requirement also applies for the frequency ranges that are less than  $F_{OoB}$  (MHz) in Table 6.6.3.1-1 from the edge of the channel bandwidth.

Table 6.6.3.3.24-1: Additional requirements

Frequency band (MHz)	Channel bandwidth / Spectrum emission limit (dBm)	Measurement bandwidth
	20 MHz	
$47 \leq f \leq 74$	-54	100 kHz
$87.5 \leq f \leq 118$	-54	100 kHz
$174 \leq f \leq 230$	-54	100 kHz
$470 \leq f \leq 862$	-54	100 kHz
$1000 \leq f \leq 5150$	-30	1 MHz
$5350 \leq f \leq 5470$	-30	1 MHz
$5725 \leq f \leq 26000$	-30	1 MHz

## 6.6.3.3.25 Minimum requirement (network signalled value "NS\_29")

When "NS\_29" is indicated in the cell, the power of any UE emission for E-UTRA channels assigned within 5150-5350 MHz and 5470-5725 MHz shall not exceed the levels specified in Table 6.6.3.3.25-1. This requirement also applies for the frequency ranges that are less than  $F_{OoB}$  (MHz) in Table 6.6.3.1-1 from the edge of the channel bandwidth.

Table 6.6.3.3.25-1: Additional requirements

Centre Frequency $F_c$ [MHz]	Protected range [MHz]	Frequency difference $\Delta f$ between centre frequency – 5240 (for $F_c=5180, 5200, 5220, 5240$ ) 5260 (for $F_c=5260, 5280, 5300, 5320$ ) (MHz)	Minimum requirement [dBm]	Measurement bandwidth
5180, 5200, 5220, 5240	$5135 \leq f \leq 5142$	-	-26	1 MHz
	$5142 < f \leq 5150$	-	-18	
	$5250 \leq f < 5251$	$\geq 10$ and $< 11$	$10(10 - \Delta f)$	
	$5251 \leq f < 5260$	$\geq 11$ and $< 20$	$-10 - 8/9(\Delta f - 11)$	
	$5260 \leq f < 5266.7$	$\geq 20$ and $< 26.7$	$-18 - 1.2(\Delta f - 20)$	
	$5266.7 \leq f \leq 5365$	-	-26	
5260, 5280, 5300, 5320	$5135 \leq f \leq 5233.3$	-	-26	
	$5233.3 < f \leq 5240$	$\geq 20$ and $< 26.7$	$-18 - 1.2(\Delta f - 20)$	
	$5240 < f \leq 5249$	$\geq 11$ and $< 20$	$-10 - 8/9(\Delta f - 11)$	
	$5249 < f \leq 5250$	$\geq 10$ and $< 11$	$10(10 - \Delta f)$	
	$5350 \leq f \leq 5365$	-	-26	
	$5365 < f \leq 5460$	-	-26	
5500, 5520, 5540, 5560, 5580, 5600, 5620, 5640, 5660, 5680, 5700	$5460 < f \leq 5470$	-	-19	
	$5470 < f \leq 5475$	-	-19	
	$5725 \leq f < 5740$	-	-19	
	$5740 \leq f \leq 5745$	-	-26	

## 6.6.3.3.26 Minimum requirement (network signalled value "NS\_30")

When "NS\_30" is indicated in the cell, the power of any UE emission for E-UTRA channels assigned within 5150-5350 MHz, 5470-5725 MHz and 5725-5850 MHz shall not exceed the levels specified in Table 6.6.3.3.26-1, Table 6.6.3.3.26-2 and Table 6.6.3.3.26-3, respectively. These requirements also apply for the frequency ranges that are less than  $F_{OoB}$  (MHz) in Table 6.6.3.1-1 from the edge of the channel bandwidth.

Table 6.6.3.3.26-1: Additional requirements for E-UTRA channels assigned within 5150-5350 MHz

Frequency band (MHz)	Channel bandwidth / Spectrum emission limit (dBm)	Measurement bandwidth
	20 MHz	
$4500 \leq f \leq 5150$	-41	1 MHz
$5350 \leq f \leq 5460$	-41	

Table 6.6.3.3.26-2: Additional requirements for E-UTRA channels assigned within 5470-5725 MHz

Frequency band (MHz)	Channel bandwidth / Spectrum emission limit (dBm)	Measurement bandwidth
	20 MHz	
$4500 \leq f \leq 5150$	-41	1 MHz
$5350 \leq f \leq 5460$	-41	
$5460 < f \leq 5470$	-27	
$5725 \leq f$	-27	

Table 6.6.3.3.26-3: Additional requirements for E-UTRA channels assigned within 5725-5850 MHz

Frequency offset of measurement filter -3dB point, $\Delta f$	Frequency offset of measurement filter centre frequency, $f_{\text{offset}}$	Minimum requirement [dBm]	Measurement bandwidth
$0 \text{ MHz} \leq \Delta f < 5 \text{ MHz}$	$0.5 \text{ MHz} \leq f_{\text{offset}} < 5.5 \text{ MHz}$	$27 - 2.28(f_{\text{offset}}/\text{MHz} - 0.5)$	1 MHz
$5 \text{ MHz} \leq \Delta f < 25 \text{ MHz}$	$5.5 \text{ MHz} \leq f_{\text{offset}} < 25.5 \text{ MHz}$	$15.6 - 0.28(f_{\text{offset}}/\text{MHz} - 0.5)$	1 MHz
$25 \text{ MHz} \leq \Delta f < 75 \text{ MHz}$	$25.5 \text{ MHz} \leq f_{\text{offset}} < 75.5 \text{ MHz}$	$10 - 0.74(f_{\text{offset}}/\text{MHz} - 0.5)$	1 MHz
$75 \text{ MHz} \leq \Delta f$	$75.5 \text{ MHz} \leq f_{\text{offset}}$	-27	1 MHz

NOTE 1: The frequency offset  $f_{\text{offset}}$  is below and above the range 5725-5850 MHz; the measurement filter -3dB point is that closest to the range 5725-5850 MHz

NOTE 2: The requirement applies when the offset of the measurement filter centre frequency is such that both -3 dB points of the measurement filter are confined within the frequency range 5725-5850 MHz.

## 6.6.3.3.27 Minimum requirement (network signalled value "NS\_31")

When "NS\_31" is indicated in the cell, the power of any UE emission for E-UTRA channels assigned within 5150-5250 MHz, 5250-5350 MHz, 5470-5725 MHz and 5725-5850 MHz shall not exceed the levels specified in Table 6.6.3.3.27-1, Table 6.6.3.3.27-2, Table 6.6.3.3.27-3 and Table 6.6.3.3.27-4, respectively. These requirements also apply for the frequency ranges that are less than  $F_{\text{OoB}}$  (MHz) in Table 6.6.3.1-1 from the edge of the channel bandwidth.

Table 6.6.3.3.27-1: Additional requirements for E-UTRA channels assigned within 5150-5250 MHz

Frequency band (MHz)	Channel bandwidth / Spectrum emission limit (dBm)	Measurement bandwidth
	20 MHz	
$f \leq 5150$	-27	1 MHz
$f \geq 5250$	-27	

Table 6.6.3.3.27-2: Additional requirements for E-UTRA channels assigned within 5250-5350 MHz

Frequency band (MHz)	Channel bandwidth / Spectrum emission limit (dBm)	Measurement bandwidth
	20 MHz	
$f \leq 5250$	-27	1 MHz
$f \geq 5350$	-27	

Table 6.6.3.3.27-3: Additional requirements for E-UTRA channels assigned within 5470-5725 MHz

Frequency band (MHz)	Channel bandwidth / Spectrum emission limit (dBm)	Measurement bandwidth
	20 MHz	
$f \leq 5470$	-27	1 MHz
$f \geq 5725$	-27	

**Table 6.6.3.3.27-4: Additional requirements for E-UTRA channels assigned within 5725-5850 MHz**

Frequency band (MHz)	Channel bandwidth / Spectrum emission limit (dBm)	Measurement bandwidth
	20 MHz	
$f \leq 5725$	-27	1 MHz
$f \geq 5850$	-27	

**6.6.3.3.28 Minimum requirement (network signalled value "NS\_36")**

When "NS\_36" is indicated in the cell, the power of any UE emission shall not exceed the levels specified in Table 6.6.3.3.28-1. This requirement also applies for the frequency ranges that are less than  $F_{OOB}$  (MHz) in Table 6.6.3.1-1 from the edge of the channel bandwidth.

**Table 6.6.3.3.28-1: Additional requirements**

Frequency band (MHz)	Channel bandwidth / Spectrum emission limit (dBm)	Measurement bandwidth
	5 MHz, 10 MHz and 15 MHz	
$470 \leq f \leq 694$	-42	8MHz
NOTE: For a 5 MHz E-UTRA carrier confined within 698MHz and 703MHz, this requirement shall be met in normal conditions only. The requirement is relaxed to -30dBm in extreme conditions.		

**6.6.3.3.29 Minimum requirement (network signalled value "NS\_38")**

When "NS\_38" is indicated in the cell, the power of any UE emission shall not exceed the levels specified in Table 6.6.3.3.29-1. This requirement also applies for the frequency ranges that are less than  $F_{OOB}$  (MHz) in Table 6.6.3.1-1 from the edge of the channel bandwidth.

**Table 6.6.3.3.29-1: Additional requirements**

Frequency band (MHz)	Channel bandwidth / Spectrum emission limit (dBm)	Measurement bandwidth
	1.4 MHz, 3 MHz, 5 MHz, 10 MHz, 15 MHz, 20 MHz	
$1400 \leq f \leq 1427$	-32	27MHz
NOTE 1: This requirement shall be verified with UE transmission power of 15 dBm.		

**6.6.3.3.30 Minimum requirement (network signalled value "NS\_39")**

When "NS\_39" is indicated in the cell, the power of any UE emission shall not exceed the levels specified in Table 6.6.3.3.30-1. This requirement also applies for the frequency ranges that are less than  $F_{OOB}$  (MHz) in Table 6.6.3.1-1 from the edge of the channel bandwidth.

**Table 6.6.3.3.30-1: Additional requirements**

Frequency band (MHz)	Channel bandwidth / Spectrum emission limit (dBm)	Measurement bandwidth
	1.4 MHz, 3 MHz, 5 MHz, 10 MHz, 15 MHz, 20 MHz	
$1475 \leq f \leq 1488$	-28	1MHz

## 6.6.3.3.31 Minimum requirement (network signalled value "NS\_40" and "NS\_41")

When "NS\_40" or "NS\_41" is indicated in the cell, the power of any UE emission for E-UTRA channels assigned within 1427-1432MHz (B51) and 1432-1452MHz (B50) shall not exceed the levels specified in Table 6.6.3.3.31-1. These requirements also apply for the frequency ranges that are less than  $F_{OoB}$  (MHz) in Table 6.6.3.1-1 from the edge of the channel bandwidth.

Table 6.6.3.3.31-1: Additional requirements for E-UTRA channels assigned within 1427-1452MHz

Frequency band (MHz)	Channel bandwidth / Spectrum emission limit (dBm)	Measurement bandwidth
	3, 5, 10, 15, 20 MHz	
1400 $\leq f \leq$ 1427	-32	27 MHz
NOTE 1: This requirement shall be verified with UE transmission power of 15 dBm.		

## 6.6.3.3.32 Minimum requirement (network signalled value "NS\_42")

When "NS\_42" is indicated in the cell, the power of any UE emission for E-UTRA channels assigned within 1492-1517 MHz (B50) shall not exceed the levels specified in Table 6.6.3.3.32-1. These requirements also apply for the frequency ranges that are less than  $F_{OoB}$  (MHz) in Table 6.6.3.1-1 from the edge of the channel bandwidth.

Table 6.6.3.3.32-1: Additional requirements for E-UTRA channels assigned within 1492-1517 MHz

Frequency band (MHz)	Channel bandwidth / Spectrum emission limit (dBm)	Measurement bandwidth
	3, 5, 10, 15, 20 MHz	
1518 $\leq f \leq$ 1559	-30	1 MHz

## 6.6.3.3.33 Minimum requirement (network signalled value "NS\_44")

When "NS\_44" is indicated in the cell, the power of any UE emission shall not exceed the levels specified in Table 6.6.3.3.33-1. This requirement also applies for the frequency ranges that are less than  $F_{OoB}$  (MHz) in Table 6.6.3.1-1 from the edge of the channel bandwidth.

Table 6.6.3.3.33-1: Additional requirements

Frequency band (MHz)	Channel bandwidth / Spectrum emission limit (dBm)	Measurement bandwidth	NOTE
	5, 10, 15, 20		
2620-2645	-15.5	5MHz	1
2645-2690	-40	1MHz	1
Note 1: The E-UTRA carrier with channel bandwidth is confined within 2570 MHz and 2615 MHz			

## 6.6.3.3.34 Minimum requirement (network signalled value "NS\_45")

When "NS\_45" is indicated in the cell, the power of any UE emission shall not exceed the levels specified in Tables 6.6.3.3.35-1 and 6.6.3.3.35-2. This requirement also applies for the frequency ranges that are less than  $F_{OoB}$  (MHz) in Table 6.6.3.1-1 from the edge of the channel bandwidth.

**Table 6.6.3.3.34-1: Additional requirements for 1.4, 3 and 5 MHz channel bandwidths**

Frequency band (MHz)	Channel bandwidth / Spectrum emission limit (dBm)	Measurement bandwidth	NOTE
	1.4, 3, 5		
$0.009 < f \leq 2477.5$	-25	1 MHz	
$2477.5 < f \leq 2478.5$	-13	1 MHz	
$2478.5 < f \leq 2483.5$	-10	1 MHz	
$2495 \leq f < 2496$	-13	1% of Channel Bandwidth	
$2496 < f \leq 2501$	-13	1 MHz	
$2501 \leq f \leq 5^{\text{th}}$ harmonic of the upper frequency edge of the UL operating band	-25	1 MHz	

**Table 6.6.3.3.34-2: Additional requirements for 10 MHz channel bandwidth**

Frequency band (MHz)	Channel bandwidth / Spectrum emission limit (dBm)	Measurement bandwidth	NOTE
	10		
$0.009 < f \leq 2473.5$	-25	1 MHz	
$2473.5 < f \leq 2478.5$	-13	1 MHz	
$2478.5 < f \leq 2483.5$	-10	1 MHz	
$2495 \leq f < 2496$	-13	1% of Channel Bandwidth	
$2496 < f \leq 2505$	-13	1 MHz	
$2505 \leq f \leq 5^{\text{th}}$ harmonic of the upper frequency edge of the UL operating band	-25	1 MHz	

### 6.6.3.3A Additional spurious emissions for CA

These requirements are specified in terms of an additional spectrum emission requirement. Additional spurious emission requirements are signalled by the network to indicate that the UE shall meet an additional requirement for a specific deployment scenario as part of the cell reconfiguration message.

**NOTE:** For measurement conditions at the edge of each frequency range, the lowest frequency of the measurement position in each frequency range should be set at the lowest boundary of the frequency range plus MBW/2. The highest frequency of the measurement position in each frequency range should be set at the highest boundary of the frequency range minus MBW/2. MBW denotes the measurement bandwidth defined for the protected band.

#### 6.6.3.3A.1 Minimum requirement for CA\_1C (network signalled value "CA\_NS\_01")

When "CA\_NS\_01" is indicated in the cell, the power of any UE emission shall not exceed the levels specified in Table 6.6.3.3A.1-1. This requirement also applies for the frequency ranges that are less than FOOB (MHz) in Table 6.6.3.1A-1 from the edge of the aggregated channel bandwidth.

**Table 6.6.3.3A.1-1: Additional requirements (PHS)**

Protected band	Frequency range (MHz)	Maximum Level (dBm)	MBW (MHz)	NOTE
E-UTRA band 34	FDL_low - FDL_high	-50	1	
Frequency range	1884.5 - 1915.7	-41	0.3	1

NOTE 1: Applicable when the aggregated channel bandwidth is confined within frequency range 1940 – 1980 MHz

#### 6.6.3.3A.2 Minimum requirement for CA\_1C (network signalled value "CA\_NS\_02")

When "CA\_NS\_02" is indicated in the cell, the power of any UE emission shall not exceed the levels specified in Table 6.6.3.3A.2-1. This requirement also applies for the frequency ranges that are less than FOOB (MHz) in Table 6.6.3.1A-1 from the edge of the aggregated channel bandwidth.

**Table 6.6.3.3A.2-1: Additional requirements**

Protected band	Frequency range (MHz)			Maximum Level (dBm)	MBW (MHz)	NOTE
E-UTRA band 34	F <sub>DL_low</sub>	-	F <sub>DL_high</sub>	-50	1	
Frequency range	1900	-	1915	-15.5	5	1, 2
Frequency range	1915	-	1920	+1.6	5	1, 2
NOTE 1: The requirement also applies for the frequency ranges that are less than F <sub>OOB</sub> (MHz) in Table 6.6.3.1A-1 and Table 6.6.3.1A-1 from the edge of the channel bandwidth.						
NOTE 2: For these adjacent bands, the emission limit could imply risk of harmful interference to UE(s) operating in the protected operating band.						

#### 6.6.3.3A.3 Minimum requirement for CA\_1C (network signalled value "CA\_NS\_03")

When "CA\_NS\_03" is indicated in the cell, the power of any UE emission shall not exceed the levels specified in Table 6.6.3.3A.3-1. This requirement also applies for the frequency ranges that are less than F<sub>OOB</sub> (MHz) in Table 6.6.3.1A-1 from the edge of the aggregated channel bandwidth.

**Table 6.6.3.3A.3-1: Additional requirements**

Protected band	Frequency range (MHz)			Maximum Level (dBm)	MBW (MHz)	NOTE
E-UTRA band 34	F <sub>DL_low</sub>	-	F <sub>DL_high</sub>	-50	1	
Frequency range	1880	-	1895	-40	1	
Frequency range	1895	-	1915	-15.5	5	1, 2
Frequency range	1915	-	1920	+1.6	5	1, 2
NOTE 1: The requirement also applies for the frequency ranges that are less than F <sub>OOB</sub> (MHz) in Table 6.6.3.1A-1 and Table 6.6.3.1A-1 from the edge of the channel bandwidth.						
NOTE 2: For these adjacent bands, the emission limit could imply risk of harmful interference to UE(s) operating in the protected operating band.						

#### 6.6.3.3A.4 Minimum requirement for CA\_38C (network signalled value "CA\_NS\_05")

When "CA\_NS\_05" is indicated in the cell, the power of any UE emission shall not exceed the levels specified in Table 6.6.3.3A.4-1. This requirement also applies for the frequency ranges that are less than F<sub>OOB</sub> (MHz) in Table 6.6.3.1A-1 from the edge of the aggregated channel bandwidth. This requirement is applicable for carriers with aggregated channel bandwidths confined in 2570 - 2615 MHz.

**Table 6.6.3.3A.4-1: Additional requirements**

Protected band	Frequency range (MHz)			Maximum Level (dBm)	MBW (MHz)	NOTE
Frequency range	2620	-	2645	-15.5	5	1, 2, 3
Frequency range	2645	-	2690	-40	1	1, 3
NOTE 1: The requirement also applies for the frequency ranges that are less than F <sub>OOB</sub> (MHz) in Table 6.6.3.1A-1 and Table 6.6.3.1A-1 from the edge of the channel bandwidth.						
NOTE 2: For these adjacent bands, the emission limit could imply risk of harmful interference to UE(s) operating in the protected operating band.						
NOTE 3: This requirement is applicable for carriers with aggregated channel bandwidths confined in 2570-2615 MHz.						

#### 6.6.3.3A.5 Minimum requirement for CA\_7C (network signalled value "CA\_NS\_06")

When "CA\_NS\_06" is indicated in the cell, the power of any UE emission shall not exceed the levels specified in Table 6.6.3.3A.5-1. This requirement also applies for the frequency ranges that are less than F<sub>OOB</sub> (MHz) in Table 6.6.3.1A-1 from the edge of the aggregated channel bandwidth.



**Table 6.6.3.3A.5-1: Additional requirements**

Protected band	Frequency range (MHz)		Maximum Level (dBm)	MBW (MHz)	NOTE
Frequency range	2570	- 2575	+1.6	5	1, 2
Frequency range	2575	- 2595	-15.5	5	1, 2
Frequency range	2595	- 2620	-40	1	

NOTE 1: The requirement also applies for the frequency ranges that are less than F<sub>OOB</sub> (MHz) in Table 6.6.3.1A-1 and Table 6.6.3.1A-1 from the edge of the channel bandwidth.

NOTE 2: For these adjacent bands, the emission limit could imply risk of harmful interference to UE(s) operating in the protected operating band.

#### 6.6.3.3A.6 Minimum requirement for CA\_39C and CA\_39C-41A (network signalled value "CA\_NS\_07")

When "CA\_NS\_07" is indicated in the cell, the power of any UE emission shall not exceed the levels specified in Table 6.6.3.3A.6-1. This requirement also applies for the frequency ranges that are less than F<sub>OOB</sub> (MHz) in Table 6.6.3.1A-1 from the edge of the aggregated channel bandwidth.

**Table 6.6.3.3A.6-1: Additional requirements**

Protected band	Frequency range (MHz)		Maximum Level (dBm)	MBW (MHz)	NOTE
Frequency range	1805	- 1855	-40	1	1
Frequency range	1855	- 1880	-15.5	5	1, 2, 3

NOTE 1: This requirement is applicable for carriers with aggregated channel bandwidths confined in 1885-1920 MHz.

NOTE 2: The requirement also applies for the frequency ranges that are less than F<sub>OOB</sub> (MHz) in Table 6.6.3.1A-1 and Table 6.6.3.1A-1 from the edge of the channel bandwidth.

NOTE 3: For these adjacent bands, the emission limit could imply risk of harmful interference to UE(s) operating in the protected operating band.

#### 6.6.3.3A.7 Minimum requirement for CA\_42C (network signalled value "CA\_NS\_08")

When "CA\_NS\_08" is indicated in the cell, the power of any UE emission shall not exceed the levels specified in Table 6.6.3.3A.7-1. This requirement also applies for the frequency ranges that are less than F<sub>OOB</sub> (MHz) in Table 6.6.3.1A-1 from the edge of the aggregated channel bandwidth.

**Table 6.6.3.3A.7-1: Additional requirements**

Frequency band (MHz)	Aggregated bandwidth / Spectrum emission limit (dBm)	MBW
	25, 30, 35, 40 MHz (Note 1)	
3400 ≤ f ≤ 3800	-23 (Note 2, Note 4)	5 MHz
	-40 (Note 3)	1 MHz

NOTE 1: Possible aggregated bandwidth for CA\_42C as specified in Table 5.6A.1-1.

NOTE 2: This requirement applies within an offset between 5 MHz and 25 MHz from the lower and from the upper edge of the channel bandwidth, whenever these frequencies overlap with the specified frequency band.

NOTE 3: This requirement applies from 3400 MHz to 25 MHz below the lower E-UTRA channel edge and from 25 MHz above the upper E-UTRA channel edge to 3800 MHz.

NOTE 4: This emission limit might imply risk of harmful interference to UE(s) operating in the protected operating band.

#### 6.6.3.3A.8 Minimum requirement for CA\_41C and CA\_41D (network signalled value "CA\_NS\_04")

When "CA\_NS\_04" is indicated in the cell, the power of any UE emission shall not exceed the levels specified in Table 6.6.3.3A.8-1. This requirement also applies for the frequency ranges that are less than F<sub>OOB</sub> (MHz) in Table 6.6.3.1A-1 from the edge of the aggregated channel bandwidth.

**Table 6.6.3.3A.8-1: Additional requirements**

Frequency band	Spectrum emission limit (dBm)	Measurement bandwidth
2490.5 MHz $\leq$ f < 2495 MHz	-13	1 MHz
9 kHz < f < 2490.5 MHz	-25	1 MHz

6.6.3.3A.9 Void

6.6.3.3A.10 Minimum requirement for CA\_48B and CA\_48C (network signalled value "CA\_NS\_10")

When "CA\_NS\_10" is indicated in the cell, the power of any UE emission shall not exceed the levels specified in Table 6.6.3.3A.10-1. This requirement also applies for the frequency ranges that are less than F<sub>008</sub> (MHz) in Table 6.6.3.1A-1 from the edge of the aggregated channel bandwidth.

**Table 6.6.3.3A.10-1: Additional requirements**

Frequency range (MHz)	Aggregated bandwidth / Spectrum emission limit (dBm)	Measurement bandwidth
	5, 10, 15, 20, 40 MHz	
9 kHz – 3530 MHz	-40	1 MHz
3530 MHz – 3540 MHz	-25	
3710 MHz – 3720 MHz	-25	
3720 MHz – 12.75 GHz	-40	

6.6.3A Void

<reserved for future use>

6.6.3B Spurious emission for UL-MIMO

For UE supporting UL-MIMO, the requirements for Spurious emissions which are caused by unwanted transmitter effects such as harmonics emission, parasitic emissions, intermodulation products and frequency conversion products are specified at each transmit antenna connector.

For UEs with two transmit antenna connectors in closed-loop spatial multiplexing scheme, the requirements in subclause 6.6.3 apply to each transmit antenna connector. The requirements shall be met with the UL-MIMO configurations specified in Table 6.2.2B-1.

If UE is configured for transmission on single-antenna port, the general requirements in subclause 6.6.3 apply.

6.6.3C Void

<reserved for future use>

6.6.3D Spurious emission for ProSe

When UE is configured for E-UTRA ProSe sidelink transmissions non-concurrent with E-UTRA uplink transmissions for E-UTRA ProSe operating bands specified in Table 5.5D-1, the requirements in subclause 6.6.3 apply.

When UE is configured for simultaneous E-UTRA ProSe sidelink and E-UTRA uplink transmissions for inter-band E-UTRA ProSe / E-UTRA bands specified in Table 5.5D-2, the UE co-existence requirements in Table 6.6.3.2A-0 in subclause 6.6.3.2A apply as specified for the corresponding inter-band aggregation with uplink assigned to two bands.

### 6.6.3F Spurious emission for category NB1 and NB2

When UE is configured for category NB1 or NB2 uplink transmissions the requirements in subclause 6.6.3 apply with an exception that boundary between category NB1 or NB2 out of band and spurious emission domain shall be  $F_{OOB} = 1.7$  MHz.

### 6.6.3G Spurious emission for V2X Communication

When UE is configured for E-UTRA V2X sidelink transmissions non-concurrent with E-UTRA uplink transmissions for E-UTRA V2X operating bands specified in Table 5.5G-1, the requirements in subclause 6.6.3 apply.

When UE is configured for simultaneous E-UTRA V2X sidelink and E-UTRA uplink transmissions for inter-band E-UTRA V2X / E-UTRA bands specified in Table 5.5G-2, the UE-coexistence requirements in Table 6.6.3G-0 in subclause 6.6.3G apply as as specified for the corresponding inter-band con-current operation with uplink assigned to two bands.

**Table 6.6.3G-0: Requirements for inter-band con-current V2X operation**

V2X concurrent band Configuration	Spurious emission						
	Protected band	Frequency range (MHz)		Maximum Level (dBm)	MBW (MHz)	NOTE	
V2X_3A-47A	E-UTRA Band 1, 5, 7, 8, 26, 28, 34, 39, 40, 44, 45, 65, 87, 88 NR band n79	F <sub>DL,low</sub>	-	F <sub>DL,high</sub>	-50	1	
	E-UTRA Band 3	F <sub>DL,low</sub>	-	F <sub>DL,high</sub>	-50	1	3
	E-UTRA Band 22, 41, 42, 52 NR band n77, n78	F <sub>DL,low</sub>	-	F <sub>DL,high</sub>	-50	1	2
	Frequency range	5925	-	5950	-30	1	7,8
	Frequency range	5815	-	5855	-30	1	7
V2X_5A-47A	E-UTRA Band 1, 3, 5, 7, 8, 10, 12, 13, 14, 17, 40, 53, 65, 85	F <sub>DL,low</sub>	-	F <sub>DL,high</sub>	-50	1	
	E-UTRA Band 26	859	-	869	-27	1	
	E-UTRA Band 41, 52 NR band n77, n78, n79	F <sub>DL,low</sub>	-	F <sub>DL,high</sub>	-50	1	2
	Frequency range	5925	-	5950	-30	1	7, 8
	Frequency range	5815	-	5855	-30	1	7
V2X_7A-47A	E-UTRA Band 1, 3, 5, 7, 8, 22, 26, 28, 34, 39, 40, 41, 42, 44, 45, 52, 65, 87, 88 NR band n77, n78	F <sub>DL,low</sub>	-	F <sub>DL,high</sub>	-50	1	
	Frequency range	2570	-	2575	+1.6	5	3, 6, 4
	Frequency range	2575	-	2595	-15.5	5	3, 6, 4
	Frequency range	2595	-	2620	-40	1	3, 6
	Frequency range	5925	-	5950	-30	1	7, 8
	Frequency range	5815	-	5855	-30	1	7
V2X_8A-47A	E-UTRA Band 1, 5, 26, 28, 34, 39, 40, 44, 45, 65, 87, 88	F <sub>DL,low</sub>	-	F <sub>DL,high</sub>	-50	1	
	E-UTRA Band 7, 22, 41, 42, 52 NR band n77, n78, n79	F <sub>DL,low</sub>	-	F <sub>DL,high</sub>	-50	1	2
	E-UTRA Band 3, 8	F <sub>DL,low</sub>	-	F <sub>DL,high</sub>	-50	1	2, 3
	Frequency range	5925	-	5950	-30	1	7, 8
	Frequency range	5815	-	5855	-30	1	7
V2X_20A-47A	E-UTRA Band 1, 3, 7, 8, 22, 31, 32, 33, 34, 40, 43, 65, 67, 87, 88	F <sub>DL,low</sub>	-	F <sub>DL,high</sub>	-50	1	
	E-UTRA Band 20	F <sub>DL,low</sub>	-	F <sub>DL,high</sub>	-50	1	3
	E-UTRA Band 38, 42, 52, 69 NR band n77, n78	F <sub>DL,low</sub>	-	F <sub>DL,high</sub>	-50	1	2
	Frequency range	758	-	788	-50	1	
	Frequency range	5925	-	5950	-30	1	7, 8
V2X_28A-47A	E-UTRA Band 1, 22, 42, 43, 65 NR band n77, n78, 87, 88	F <sub>DL,low</sub>	-	F <sub>DL,high</sub>	-50	1	2
	E-UTRA Band 1	F <sub>DL,low</sub>	-	F <sub>DL,high</sub>	-50	1	10, 11
	E-UTRA Band 3, 7, 8, 20, 31, 38, 40 NR band n79	F <sub>DL,low</sub>	-	F <sub>DL,high</sub>	-50	1	
	Frequency range	470	-	694	-42	8	3, 12
	Frequency range	470	-	710	-26.2	6	13
	Frequency range	662	-	694	-26.2	6	3
	Frequency range	758	-	773	-32	1	3
	Frequency range	773	-	803	-50	1	
	Frequency range	5925	-	5950	-30	1	7, 8
	Frequency range	5815	-	5855	-30	1	7
V2X_34A-47A	E-UTRA Band 1, 3, 5, 7, 8, 11, 18, 19, 20, 21, 22, 26, 28, 31, 32, 33, 34, 38, 39, 40, 41, 42, 43, 44, 45, 52, 65, 67, 69, 87, 88 NR Band n78, n79	F <sub>DL,low</sub>	-	F <sub>DL,high</sub>	-50	1	9
	NR Band n77	F <sub>DL,low</sub>	-	F <sub>DL,high</sub>	-50	1	2, 9
	Frequency range	5925	-	5950	-30	1	7, 8
	Frequency range	5815	-	5855	-30	1	7

V2X_39A-47A	E-UTRA Band 1, 3, 5, 7, 8, 22, 26, 28, 34, 39, 40, 41, 42, 44, 45, 52, 65 NR Band n79	$F_{DL\_low}$	-	$F_{DL\_high}$	-50	1	
	NR Band n77, n78	$F_{DL\_low}$	-	$F_{DL\_high}$	-50	1	2, 9
	Frequency range	1805	-	1855	[-40]	1	5
	Frequency range	1855	-	1880	[-15.5]	5	3, 4, 5
	Frequency range	5925	-	5950	-30	1	7, 8
	Frequency range	5815	-	5855	-30	1	7
V2X_41A-47A	E-UTRA Band 1, 3, 5, 7, 8, 22, 26, 28, 34, 39, 40, 41, 42, 44, 45, 52, 65 NR Band n77, n78	$F_{DL\_low}$	-	$F_{DL\_high}$	-50	1	
	NR Band n79	$F_{DL\_low}$	-	$F_{DL\_high}$	-50	1	2
	Frequency range	5925	-	5950	-30	1	7, 8
	Frequency range	5815	-	5855	-30	1	7
V2X_71A-47A	E-UTRA Band 5, 26, 53	$F_{DL\_low}$	-	$F_{DL\_high}$	-50	1	
	E-UTRA Band 41	$F_{DL\_low}$	-	$F_{DL\_high}$	-50	1	2
	Frequency range	5925	-	5950	-30	1	7, 8
	Frequency range	5815	-	5855	-30	1	7
NOTE 1: $F_{DL\_low}$ and $F_{DL\_high}$ refer to each E-UTRA frequency band specified in Table 5.5-1							
NOTE 2: As exceptions, measurements with a level up to the applicable requirements defined in Table 6.6.3.1-2 are permitted for each assigned E-UTRA carrier used in the measurement due to 2 <sup>nd</sup> , 3 <sup>rd</sup> , 4 <sup>th</sup> [or 5 <sup>th</sup> ] harmonic spurious emissions. In case the exceptions are allowed due to spreading of the harmonic emission the exception is also allowed for the first 1 MHz frequency range immediately outside the harmonic emission on both sides of the harmonic emission. This results in an overall exception interval centred at the harmonic emission of (2MHz + N x L <sub>CRB</sub> x 180kHz), where N is 2, 3 or 4 for the 2 <sup>nd</sup> , 3 <sup>rd</sup> or 4 <sup>th</sup> harmonic respectively. The exception is allowed if the measurement bandwidth (MBW) totally or partially overlaps the overall exception interval.							
NOTE 3: These requirements also apply for the frequency ranges that are less than $F_{OOB}$ (MHz) in Table 6.6.3.1-1 and Table 6.6.3.1A-1 from the edge of the aggregated channel bandwidth.							
NOTE 4: For these adjacent bands, the emission limit could imply risk of harmful interference to UE(s) operating in the protected operating band.							
NOTE 5: This requirement is only applicable for carriers with bandwidth confined within 1885-1920 MHz (requirement for carriers with at least 1RB confined within 1880 - 1885 MHz is not specified). This requirement applies for an uplink transmission bandwidth less than or equal to 54 RB for carriers of 15 MHz bandwidth when carrier center frequency is within the range 1892.5 - 1894.5 MHz and for carriers of 20 MHz bandwidth when carrier center frequency is within the range 1895 - 1903 MHz.							
NOTE 6: As exceptions, measurements with a level up to the applicable requirement of -38 dBm/MHz is permitted for each assigned E-UTRA carrier used in the measurement due to 2 <sup>nd</sup> harmonic spurious emissions. An exception is allowed if there is at least one individual RB within the transmission bandwidth (see Figure 5.6-1) for which the 2 <sup>nd</sup> harmonic totally or partially overlaps the measurement bandwidth (MBW).							
NOTE 7: Applicable when NS_33 or NS_34 is configured by the pre-configured radio parameters.							
NOTE 8: In the frequency range x-5950MHz, SE requirement of -30dBm/MHz should be applied; where x = max (5925, $f_c + 15$ ), where $f_c$ is the channel centre frequency.							
NOTE 9: For non synchronised TDD operation to meet these requirements some restriction will be needed for either the operating band or protected band							
NOTE 10: Applicable when the assigned E-UTRA carrier is confined within 718 MHz and 748 MHz and when the channel bandwidth used is 5 or 10 MHz.							
NOTE 11: As exceptions, measurements with a level up to the applicable requirement of -36 dBm/MHz is permitted for each assigned E-UTRA carrier used in the measurement due to 3 <sup>rd</sup> harmonic spurious emissions. An exception is allowed if there is at least one individual RB within the transmission bandwidth (see Figure 5.6-1) for which the 3 <sup>rd</sup> harmonic totally or partially overlaps the measurement bandwidth (MBW).							
NOTE 12: This requirement is applicable in the case of a 10 MHz E-UTRA carrier confined within 703 MHz and 733 MHz, otherwise the requirement of -25 dBm with a measurement bandwidth of 8 MHz applies.							
NOTE 13: This requirement is applicable for 5 and 10 MHz E-UTRA channel bandwidth allocated within 718-728MHz. For carriers of 10 MHz bandwidth, this requirement applies for an uplink transmission bandwidth less than or equal to 30 RB with $RB_{start} > 1$ and $RB_{start} < 48$ .							

For intra-band contiguous multi-carrier operation, the boundary between E-UTRA out of band and spurious emission domain for intra-band contiguous carrier aggregation specified in Table 6.6.3.1A-1 shall apply.

For intra-band contiguous multi-carrier operation, the spurious emission requirements in Table 6.6.3G-1 shall apply for coexistence with protected bands.

NOTE: For measurement conditions at the edge of each frequency range, the lowest frequency of the measurement position in each frequency range should be set at the lowest boundary of the frequency range plus MBW/2. The highest frequency of the measurement position in each frequency range should be set at the highest boundary of the frequency range minus MBW/2. MBW denotes the measurement bandwidth defined for the protected band.

**Table 6.6.3G-1: Requirements for intraband multi-carrier V2X operation**

V2X multi-carrier Configuration	Spurious emission					
	Protected band	Frequency range (MHz)		Maximum Level (dBm)	MBW (MHz)	NOTE
V2X_47 B	E-UTRA Band 1, 3, 5, 7, 8, 22, 26, 28, 34, 39, 40, 41, 42, 44, 45, 50, 51, 52, 65 NR band n77, n78, n79	F <sub>DL,low</sub>	-	F <sub>DL,high</sub>	-50	1

For V2X UEs supporting Transmit Diversity, the requirements specified for single carrier shall apply to each transmit antenna connector.

If V2X UE is configured for transmission on single-antenna connector, the general requirements specified for single carrier shall apply to the active antenna connector.

## 6.6A Void

## 6.6B Void

## 6.7 Transmit intermodulation

The transmit intermodulation performance is a measure of the capability of the transmitter to inhibit the generation of signals in its non linear elements caused by presence of the wanted signal and an interfering signal reaching the transmitter via the antenna.

### 6.7.1 Minimum requirement

User Equipment(s) transmitting in close vicinity of each other can produce intermodulation products, which can fall into the UE, or eNode B receive band as an unwanted interfering signal. The UE intermodulation attenuation is defined by the ratio of the mean power of the wanted signal to the mean power of the intermodulation product when an interfering CW signal is added at a level below the wanted signal at each of the transmitter antenna port with the other antenna port(s) if any is terminated. Both the wanted signal power and the intermodulation product power are measured through E-UTRA rectangular filter with measurement bandwidth shown in Table 6.7.1-1.

The requirement of transmitting intermodulation is prescribed in Table 6.7.1-1.

**Table 6.7.1-1: Transmit Intermodulation**

BW Channel (UL)	5MHz		10MHz		15MHz		20MHz	
	5MHz	10MHz	10MHz	20MHz	15MHz	30MHz	20MHz	40MHz
Interference Signal Frequency Offset								
Interference CW Signal Level	-40dBc							
Intermodulation Product	-29dBc	-35dBc	-29dBc	-35dBc	-29dBc	-35dBc	-29dBc	-35dBc
Measurement bandwidth	4.5MHz	4.5MHz	9.0MHz	9.0MHz	13.5MHz	13.5MHz	18MHz	18MHz

### 6.7.1A Minimum requirement for CA

User Equipment(s) transmitting in close vicinity of each other can produce intermodulation products, which can fall into the UE, or eNode B receive band as an unwanted interfering signal. The UE intermodulation attenuation is defined by the ratio of the mean power of the wanted signal to the mean power of the intermodulation product on both component carriers when an interfering CW signal is added at a level below the wanted signal at each of the transmitter antenna port with the other antenna port(s) if any is terminated. Both the wanted signal power and the intermodulation product power are measured through rectangular filter with measurement bandwidth shown in Table 6.7.1A-1.

For inter-band carrier aggregation with one component carrier per operating band and the uplink active in two E-UTRA bands, the requirement is specified in Table 6.7.1-1 which shall apply on each component carrier with both component carriers active.

For intra-band contiguous carrier aggregation the requirement of transmitting intermodulation is specified in Table 6.7.1A-1.

**Table 6.7.1A-1: Transmit Intermodulation**

CA bandwidth class(UL)	B and C	
Interference Signal Frequency Offset	$BW_{\text{Channel\_CA}}$	$2 \cdot BW_{\text{Channel\_CA}}$
Interference CW Signal Level	-40dBc	
Intermodulation Product	-29dBc	-35dBc
Measurement bandwidth	$BW_{\text{Channel\_CA}} - 2 \cdot BW_{\text{GB}}$	

For combinations of intra-band and inter-band carrier aggregation with three uplink component carriers (up to two contiguously aggregated carriers per band) transmit intermodulations is defined as follows. For the E-UTRA band supporting one component carrier the requirement specified in Table 6.7.1-1 apply. For the E-UTRA band supporting two contiguous component carriers the requirements specified in Table 6.7.1A-1 apply.

### 6.7.1B Minimum requirement for UL-MIMO

For UE supporting UL-MIMO, the transmit intermodulation requirements are specified at each transmit antenna connector and the wanted signal is defined as the sum of output power at each transmit antenna connector.

For UEs with two transmit antenna connectors in closed-loop spatial multiplexing scheme, the requirements in subclause 6.7.1 apply to each transmit antenna connector. The requirements shall be met with the UL-MIMO configurations specified in Table 6.2.2B-2.

If UE is configured for transmission on single-antenna port, the requirements in subclause 6.7.1 apply.

### 6.7.1F Minimum requirement for category NB1 and NB2

The UE category NB1 and NB2 transmitter intermodulation attenuation is defined by the ratio of the mean power of the wanted signal to the mean power of the intermodulation product as defined in Table 6.7.1F-1 when an interfering CW signal is added at a level below the wanted signal at the transmitter antenna port. Both the wanted signal power and the intermodulation product power are measured through rectangular filter with measurement bandwidth shown in Table 6.7.1F-1.



**Table 6.7.1F-1: UE category NB1 and NB2 transmitter IM requirement**

Parameters for transmitter intermodulation		
BW Channel (UL)	15 kHz (1 tone at sub-carrier 5 or 6)	
Interference Signal Frequency Offset	180 kHz	360 kHz
Interference CW Signal Level	-40dBc	
Intermodulation Product	-20 dBc	-39 dBc
Measurement bandwidth	30 kHz	30 kHz

### 6.7.1G Minimum requirement for V2X Communication

When UE is configured for E-UTRA V2X sidelink transmissions non-concurrent with E-UTRA uplink transmissions for E-UTRA V2X operating bands specified in Table 5.5G-1, the requirements in subclause 6.7.1 apply for E-UTRA V2X sidelink transmission.

When UE is configured for simultaneous E-UTRA V2X sidelink and E-UTRA uplink transmissions for inter-band E-UTRA V2X / E-UTRA bands specified in Table 5.5G-2, the requirements in subclause 6.7.1 apply for V2X sidelink transmission and the E-UTRA uplink transmission.

For intra-band contiguous multi-carrier operation, the transmit intermodulation requirement for CA Bandwidth Class B specified in subclause 6.7.1A shall apply for V2X Bandwidth Class B, the general CA spectrum emission mask for CA Bandwidth Class C specified in subclause 6.7.1A shall apply for V2X Bandwidth Class C and C<sub>1</sub>.

For V2X UE supporting Transmit Diversity, if the UE transmits on two antenna connectors at the same time, the requirements specified for single carrier shall apply to each transmit antenna connector. If the UE transmits on one antenna connector, the requirements specified for single carrier shall apply to the active antenna connector.

## 6.8 Void

### 6.8A Void

### 6.8B Time alignment error for UL-MIMO

For UE(s) with multiple transmit antenna connectors supporting UL-MIMO, this requirement applies to frame timing differences between transmissions on multiple transmit antenna connectors in the closed-loop spatial multiplexing scheme.

The time alignment error (TAE) is defined as the average frame timing difference between any two transmissions on different transmit antenna connectors.

#### 6.8B.1 Minimum Requirements

For UE(s) with multiple transmit antenna connectors, the Time Alignment Error (TAE) shall not exceed 130 ns.

6.8C Void

6.8D Void

6.8E Void

6.8F Void

6.8G Time alignment error

For V2X UE(s) with two transmit antenna connectors in Transmit Diversity scheme, this requirement applies to frame timing differences between transmissions on two transmit antenna connectors. The Time Alignment Error (TAE) shall not exceed [260] ns.

---

## 7 Receiver characteristics

### 7.1 General

Unless otherwise stated the receiver characteristics are specified at the antenna connector(s) of the UE. For UE(s) with an integral antenna only, a reference antenna(s) with a gain of 0 dBi is assumed for each antenna port(s). UE with an integral antenna(s) may be taken into account by converting these power levels into field strength requirements, assuming a 0 dBi gain antenna. For UEs with more than one receiver antenna connector, identical interfering signals shall be applied to each receiver antenna port if more than one of these is used (diversity).

The levels of the test signal applied to each of the antenna connectors shall be as defined in the respective sections below.

With the exception of subclause 7.3, the requirements shall be verified with the network signalling value NS\_01 configured (Table 6.2.4-1).

All the parameters in clause 7 are defined using the UL reference measurement channels specified in Annexes A.2.2 and A.2.3, the DL reference measurement channels specified in Annex A.3.2 and using the set-up specified in Annex C.3.1.

For the additional requirements for intra-band non-contiguous carrier aggregation of two or more sub-blocks, an in-gap test refers to the case when the interfering signal is located at a negative offset with respect to the assigned lowest channel frequency of the highest sub-block and located at a positive offset with respect to the assigned highest channel frequency of the lowest sub-block.

For the additional requirements for intra-band non-contiguous carrier aggregation of two or more sub-blocks, an out-of-gap test refers to the case when the interfering signal(s) is (are) located at a positive offset with respect to the assigned channel frequency of the highest carrier frequency, or located at a negative offset with respect to the assigned channel frequency of the lowest carrier frequency.

For the additional requirements for intra-band non-contiguous carrier aggregation of two or more sub-blocks with channel bandwidth larger than or equal to 5 MHz, the existing adjacent channel selectivity requirements, in-band blocking requirements (for each case), and narrow band blocking requirements apply for in-gap tests only if the corresponding interferer frequency offsets with respect to the two measured carriers satisfy the following condition in relation to the sub-block gap size  $W_{\text{gap}}$  for at least one of these carriers  $j = 1, 2$ , so that the interferer frequency position does not change the nature of the core requirement tested:

$$W_{\text{gap}} \geq 2 \cdot |F_{\text{Interferer (offset)}_j} - \text{BW}_{\text{Channel}(j)}|$$

where  $F_{\text{Interferer (offset)}_j}$  for a sub-block with a single component carrier is the interferer frequency offset with respect to carrier  $j$  as specified in subclause 7.5.1, subclause 7.6.1 and subclause 7.6.3 for the respective requirement and  $\text{BW}_{\text{Channel}(j)}$  the channel bandwidth of carrier  $j$ .  $F_{\text{Interferer (offset)}_j}$  for a sub-block with two or more contiguous component

carriers is the interference frequency offset with respect to the carrier adjacent to the gap is specified in subclause 7.5.1A, 7.6.1A and 7.6.3A. The interferer frequency offsets for adjacent channel selectivity, each in-band blocking case and narrow-band blocking shall be tested separately with a single in-gap interferer at a time.

For a ProSe UE that supports both ProSe Direct Discovery and ProSe Direct Communication, the receiver characteristics specified in clause 7 for ProSe Direct Communication shall apply.

For ProSe Direct Discovery and ProSe Direct Communication on E-UTRA ProSe operating bands that correspond to TDD E-UTRA operating bands as specified in subclause 5.5D, the only additional requirement for ProSe specified in subclause 7.4.1D is applicable.

## 7.2 Diversity characteristics

The requirements in Section 7 assume that the receiver is equipped with two Rx port as a baseline. These requirements apply to all UE categories unless stated otherwise. Additional requirements apply for UE(s) equipped with four Rx ports. These additional requirements also apply for supported band combinations for which the UE can operate using up to four Rx ports while configured with carrier aggregation. With the exception of subclause 7.9 all requirements shall be verified by using both (all) antenna ports simultaneously.

NOTE: for an operating band in which the UE can operate using up to four Rx ports, it suffices to verify for conformance the additional requirements applicable for four Rx ports [except for REFSENS].

NOTE: Implementation of 4 antenna ports for all operating bands supported by the UE is not mandated.

For a category 0, a category [M 1] , category 1bis, category NB1 and NB2 UE the requirements in Section 7 assume that the receiver is equipped with single Rx port.

## 7.3 Reference sensitivity power level

The reference sensitivity power level REFSENS is the minimum mean power applied to each one of the UE antenna ports for all UE categories except category 0, category M1, category M2, and category 1bis, or to the single antenna port for UE category 0, UE category M1, category M2, and UE category 1bis, at which the throughput shall meet or exceed the requirements for the specified reference measurement channel.

The throughput for the REFSENS test is measured based on the Transmission Mode 1 unless specified otherwise.

### 7.3.1 Minimum requirements (QPSK)

The throughput shall be  $\geq 95\%$  of the maximum throughput of the reference measurement channels as specified in Annexes A.2.2, A.2.3 and A.3.2 (with one sided dynamic OCNG Pattern OP.1 FDD/TDD for the DL-signal as described in Annex A.5.1.1/A.5.2.1) with parameters specified in Table 7.3.1-1 and Table 7.3.1-2

**Table 7.3.1-1: Reference sensitivity QPSK  $P_{\text{REFSENS}}$**

Channel bandwidth							
E-UTRA Band	1.4 MHz (dBm)	3 MHz (dBm)	5 MHz (dBm)	10 MHz (dBm)	15 MHz (dBm)	20 MHz (dBm)	Duplex Mode
1			-100	-97	-95.2	-94	FDD
2	-102.7	-99.7	-98	-95	-93.2	-92	FDD
3	-101.7	-98.7	-97	-94	-92.2	-91	FDD
4	-104.7	-101.7	-100	-97	-95.2	-94	FDD
5	-103.2	-100.2	-98	-95			FDD
6			-100	-97			FDD
7			-98	-95	-93.2	-92	FDD
8	-102.2	-99.2	-97	-94			FDD
9			-99	-96	-94.2	-93	FDD
10			-100	-97	-95.2	-94	FDD
11			-100	-97			FDD
12	-101.7	-98.7	-97	-94			FDD
13			-97	-94			FDD
14			-97	-94			FDD
...							
17			-97	-94			FDD
18			-100 <sup>7</sup>	-97 <sup>7</sup>	-95.2 <sup>7</sup>		FDD
19			-100	-97	-95.2		FDD
20			-97	-94	-91.2	-90	FDD
21			-100	-97	-95.2		FDD
22			-97	-94	-92.2	-91	FDD
23	-104.7	-101.7	-100	-97	-95.2	-94	FDD
24			-100	-97			FDD
25	-101.2	-98.2	-96.5	-93.5	-91.7	-90.5	FDD
26	-102.7	-99.7	-97.5 <sup>6</sup>	-94.5 <sup>6</sup>	-92.7 <sup>6</sup>		FDD
27	-103.2	-100.2	-98	-95			FDD
28		-100.2	-98.5	-95.5	-93.7	-91	FDD
30			-99	-96			FDD
31	-99.0	-95.7	-93.5				FDD
...							
33			-100	-97	-95.2	-94	TDD
34			-100	-97	-95.2		TDD
35	-106.2	-102.2	-100	-97	-95.2	-94	TDD
36	-106.2	-102.2	-100	-97	-95.2	-94	TDD
37			-100	-97	-95.2	-94	TDD
38			-100	-97	-95.2	-94	TDD
39			-100	-97	-95.2	-94	TDD
40			-100	-97	-95.2	-94	TDD
41			-98	-95	-93.2	-92	TDD
42			-99	-96	-94.2	-93	TDD
43			-99	-96	-94.2	-93	TDD
44		[-100.2]	[-98]	[-95]	[-93.2]	[-92]	TDD
45			-100	-97	-95.2	-94	TDD
48			-99	-96	-94.2	-93	TDD
50		-102.2	-100	-97	-95.2	-94	TDD
51		-102.2	-100				TDD
52			-99	-96	-94.2	-93	TDD
53	-106.2	-102.2	-100	-97			TDD
...							
65	-104.2	-101.2	-99.5	-96.5	-94.7	-93.5	FDD
66	-104.2	-101.2	-99.5	-96.5	-94.7	-93.5	FDD

68			-98.5	-95.5	-93.7		FDD
...							
70			-100	-97	-95.2	-94	FDD
71			-97.2	-94.2	-92.0	-87.5	FDD
72	-99.0	-95.7	-93.5				FDD
73	-99.0	-95.7	-93.5				FDD
74	-104.7 <sup>8</sup>	-101.7 <sup>8</sup>	-99.5 <sup>8</sup>	-96.5 <sup>8</sup>	-94.7 <sup>8</sup>	-89.8 <sup>8</sup>	FDD
85			-97	-94			FDD
87	-99.0	-95.7	-93.5				FDD
88	-99.0	-95.7	-93.5				FDD

NOTE 1: The transmitter shall be set to  $P_{UMAX}$  as defined in subclause 6.2.5  
NOTE 2: Reference measurement channel is A.3.2 with one sided dynamic OCNG Pattern OP.1 FDD/TDD as described in Annex A.5.1.1/A.5.2.1  
NOTE 3: The signal power is specified per port  
NOTE 4: For the UE which supports both Band 3 and Band 9 the reference sensitivity level is FFS.  
NOTE 5: For the UE which supports both Band 11 and Band 21 the reference sensitivity level is FFS.  
NOTE 6: <sup>6</sup> indicates that the requirement is modified by -0.5 dB when the carrier frequency of the assigned E-UTRA channel bandwidth is within 865-894 MHz.  
NOTE 7: For a UE that support both Band 18 and Band 26, the reference sensitivity level for Band 26 applies for the applicable channel bandwidths.  
NOTE 8: <sup>8</sup> indicates that the requirement is modified by -0.5 dB when the assigned E-UTRA channel bandwidth is confined within 1475.9-1510.9 MHz.

For UE(s) equipped with 4 antenna ports, the minimum requirement for reference sensitivity in Table 7.3.1-1 shall be modified by the amount given in  $\Delta R_{IB,4R}$  in Table 7.3.1-1a for the applicable E-UTRA bands.

**Table 7.3.1-1a:  $\Delta R_{IB,4R}$**

E-UTRA Band	$\Delta R_{IB,4R}$ [dB]
1, 2, 3, 4, 7, 20, 21, 25, 30, 34, 39, 40, 41, 66	- 2.7
42, 43, 52	- 2.2

For UE(s) equipped with 8 antenna ports, the minimum requirement for reference sensitivity in Table 7.3.1-1 shall be modified by the amount given in  $\Delta R_{IB,8R}$  in Table 7.3.1-1aa for the applicable E-UTRA bands.

**Table 7.3.1-1aa:  $\Delta R_{IB,8R}$**

E-UTRA Band	$\Delta R_{IB,8R}$ [dB]
41, 42, 43	- 4

For UE(s) supporting power class 1 in any of the E-UTRA bands given in table 7.3.1-1b, the following exceptions due to the high power leakage or blocking issue shall apply. The throughput shall be  $\geq 95\%$  of the maximum throughput of the reference measurement channels as specified in Annexes A.2.2, A.2.3 and A.3.2 (with one sided dynamic OCNG Pattern OP.1 FDD/TDD for the DL-signal as described in Annex A.5.1.1/A.5.2.1) with parameters specified in Table 7.3.1-1b and Table 7.3.1-2.

**Table 7.3.1-1b: Reference sensitivity for power class 1 QPSK  $P_{REFSENS}$  (Exception due to high power issue)**

E-UTRA Band	Channel bandwidth						Duplex Mode
	1.4 MHz (dBm)	3 MHz (dBm)	5 MHz (dBm)	10 MHz (dBm)	15 MHz (dBm)	20 MHz (dBm)	
20			-92.8	-90.9	-89.5	-88.5	FDD

NOTE 1: The transmitter shall be set to  $P_{UMAX}$  as defined in subclause 6.2.5  
NOTE 2: Reference measurement channel is A.3.2 with one sided dynamic OCNG Pattern OP.1 FDD/TDD as described in Annex A.5.1.1/A.5.2.1  
NOTE 3: The signal power is specified per port.

The reference receive sensitivity (REFSENS) requirement specified in Table 7.3.1-1 (two antenna ports) and Table 7.3.1-1a (four antenna ports) shall be met for an uplink transmission bandwidth less than or equal to that specified in Table 7.3.1-2.

NOTE: Table 7.3.1-2 is intended for conformance tests and does not necessarily reflect the operational conditions of the network, where the number of uplink and downlink allocated resource blocks will be practically constrained by other factors. Typical receiver sensitivity performance with HARQ retransmission enabled and using a residual BLER metric relevant for e.g. Speech Services is given in the Annex G (informative). For the UE which supports inter-band carrier aggregation configuration with the uplink in one or two E-UTRA bands, the minimum requirement for reference sensitivity in Table 7.3.1-1 and Table 7.3.1-1a shall be increased by the amount given in  $\Delta R_{IB,c}$  in Table 7.3.1-1A, Table 7.3.1-1B and Table 7.3.1-1C for the applicable E-UTRA bands where unless otherwise stated, the same  $\Delta R_{IB,c}$  is applicable to E-UTRA band(s) part for CA configurations which have the same E-UTRA operating band combination.

**Table 7.3.1-1A:  $\Delta R_{B,c}$  (two bands)**



E-UTRA operating band combination	E-UTRA Band	$\Delta R_{IS,c}$ [dB]
CA_1-3, CA_1-1-3, CA_1-1-3-3, CA_1-3-3	1	0
	3	0
CA_1-5, CA_1-1-5	1	0
	5	0
CA_1-7, CA_1-1-7, CA_1-7-7	1	0
	7	0
CA_1-8	1	0
	8	0
CA_1-11	1	0
	11	0
CA_1-18	1	0
	18	0
CA_1-19	1	0
	19	0
CA_1-20	1	0
	20	0
CA_1-21	1	0
	21	0
CA_1-26	1	0
	26	0
CA_1-28, CA_1-1-28	1	0
	28	0.2
CA_1-32	1	0
	32	0
CA_1-38	1	0
	38	0
CA_1-40	1	0
	40	0
CA_1-41 <sup>a</sup>	1	0
	41	0
CA_1-42, CA_1-42-42	1	0
	42	0.5
CA_1-43	1	0
	43	0.5
CA_1-46	1	0
CA_2-4, CA_2-2-4, CA_2-4-4, CA_2-2-4-4	2	0.3
	4	0.3
CA_2-5, CA_2-2-5	2	0
	5	0
CA_2-7, CA_2-2-7, CA_2-7-7	2	0
	7	0
CA_2-12, CA_2-2-12, CA_2-12-12, CA_2-2-12-12	2	0
	12	0
CA_2-13, CA_2-2-13	2	0
	13	0
CA_2-14, CA_2-2-14	2	0
	14	0
CA_2-17	2	0
	17	0.5
CA_2-26	2	0
	26	0
CA_2-28	2	0
	28	0
CA_2-29, CA_2-2-29	2	0
CA_2-30, CA_2-2-30	2	0.4
	30	0.5
CA_2-46, CA_2-2-46	2	0

CA_2-48,	2	0.2
CA_2-48-48	48	0.5
CA_2-49	2	0.2
CA_2-66,	2	0.3
CA_2-2-66,	66	0.3
CA_2-66-66,		
CA_2-2-66-66,		
CA_2-66-66-66		
CA_2-71,	2	0
CA_2-2-71	71	0
CA_3-5,	3	0
CA_3-3-5	5	0
CA_3-7, CA_3-	3	0
3-7, CA_3-7-7,	7	0
CA_3-3-7-7		
CA_3-8, CA_3-	3	0
3-8	8	0
CA_3-11	3	0.3
	11	0.5
CA_3-18	3	0
	18	0
CA_3-19,	3	0
CA_3-3-19	19	0
CA_3-20,	3	0
CA_3-3-20	20	0
CA_3-21,	3	0.3
CA_3-3-21	21	0.5
CA_3-26	3	0
	26	0
CA_3-27	3	0
	27	0
CA_3-28	3	0
	28	0
CA_3-31	3	0
	31	0.2
CA_3-32	3	0
	32	0
CA_3-38	3	0
	38	0
CA_3-40,	3	0
CA_3-40-40	40	0
CA_3-41,	3	0
	CA_3-3-41	41
0.5 <sup>11</sup>		
CA_3-42,	3	0.2
CA_3-3-42,	42	0.5
CA_3-42-42		
CA_3-43	3	0
	43	0.5
CA_3-46,	3	0
CA_3-3-46	3	0
CA_4-5, CA_4-	4	0
4-5	5	0
CA_4-7, CA_4-	4	0.5
4-7, CA_4-7-7	7	0.5
CA_4-12,	4	0
CA_4-4-12,	12	0.5
CA_4-12-12,		
CA_4-4-12-12		
CA_4-13,	4	0
CA_4-4-13	13	0
CA_4-17	4	0
	17	0.5
CA_4-27	4	0
	27	0
CA_4-28	4	0

	28	0.2
CA_4-29, CA_4-4-29	4	0
CA_4-30, CA_4-4-30	4	0.4
	30	0.5
CA_4-46	4	0
CA_4-48	4	0
	48	0.5
CA_4-71, CA_4-4-71	4	0
	71	0
CA_5-7, CA_5- 7-7	5	0
	7	0
CA_5-12, CA_5-12-12	5	0.5
	12	0.3
CA_5-13	5	0
	13	0
CA_5-17	5	0.5
	17	0.3
CA_5-25	5	0
	25	0
CA_5-28	5	0
	28	0
CA_5-29	5	0
CA_5-30	5	0
	30	0
CA_5-38	5	0
	38	0
CA_5-40, CA_5-5-40, CA_5-40-40	5	0
	40	0
CA_5-41	5	0
	41	0
CA_5-48	5	0
	48	0
CA_5-66, CA_5-5-66, CA_5-66-66, CA_5-5-66-66	5	0
	66	0
CA_7-8, CA_7- 7-8	7	0
	8	0.2
CA_7-12	7	0
	12	0
CA_7-13	7	0
	13	0
CA_7-20, CA_7-7-20	7	0
	20	0
CA_7-22	7	0
	22	0.5
CA_7-26, CA_7-7-26	7	0
	26	0
CA_7-28, CA_7-7-28	7	0
	28	0
CA_7-29, CA_7-7-29	7	0
CA_7-30	7	0.5
	30	0.5
CA_7-32	7	0
	32	0
CA_7-40	7	0
	40	0.5
CA_7-42, CA_7-42-42	7	0
	42	0.5
CA_7-46, CA_7-7-46	7	0
	7	0.5

CA_7-66, CA_7-7-66, CA_7-66-66, CA_7-7-66-66	66	0.5
CA_8-11	8	0
	11	0
CA_8-20	8	0
	20	0
CA_8-27	8	0.3
	27	0.3
CA_8-28 <sup>13</sup>	8	0.2
	28	0.1
CA_8-32	8	0
	32	0
CA_8-38	8	0
	38	0
CA_8-39	8	0
	39	0
CA_8-40	8	0
	40	0
CA_8-41	8	0
	41	0
CA_8-42	8	0.2
	42	0.5
CA_8-46	8	0
CA_11-18	11	0
	18	0
CA_11-26	11	0
	26	0
CA_11-28	11	0
	28	0.2
CA_11-41	11	0
	41	0
CA_11-42	11	0
	42	0.5
CA_11-46	11	0
CA_12-25	12	0
	25	0
CA_12-30	12	0
	30	0
CA_12-46	12	0
	46	0
CA_12-48	12	0
	48	0
CA_12-66, CA_12-66-66	12	0.5
	66	0
CA_13-46, CA_13-46-46	13	0
	13	0
CA_13-48, CA_13-48-48	48	0
	13	0
CA_13-66, CA_13-66-66	66	0
	14	0
CA_14-30	30	0
	14	0
CA_14-66, CA_14-66-66, CA_14-66-66- 66	66	0
	18	0
CA_18-28 <sup>9</sup>	28	0
	18	0
CA_18-41	41	0
	18	0
CA_18-42	42	0.5
	19	0
CA_19-21	21	0

CA_19-28 <sup>9</sup>	19	0
	28	0
CA_19-42	19	0
	42	0.5
CA_19-46	19	0
CA_20-28	20	0
	28	0
CA_20-31	20	0
	31	0
CA_20-32	20	0
CA_20-38	20	0
	38	0
CA_20-40, CA_20-40-40	20	0
	40	0
CA_20-41	20	0
	41	0
CA_20-42, CA_20-42-42	20	0
	42	0.5
CA_20-43	20	0
	43	0.5
CA_20-67	20	0
CA_20-75	20	0
CA_20-76	20	0
CA_21-28	21	0
	28	0
CA_21-42	21	0
	42	0.5
CA_21-46	21	0
CA_23-29	23	0
CA_25-26, CA_25-25-26	25	0
	26	0
CA_25-41, CA_25-25-41	25	0
	41	0 <sup>10</sup>
CA_25-46	25	0.5 <sup>11</sup>
	46	0
CA_26-41	26	0
	41	0
CA_26-46	26	0
CA_26-48, CA_26-48-48	26	0
	48	0
CA_26-66	26	0
	66	0
CA_28-32	28	0
CA_28-38	28	0
	38	0
CA_28-40	28	0
	40	0
CA_28-41	28	0
	41	0
CA_28-42,	28	0.2
CA_28-42-42	42	0.5
CA_28-46	28	0
CA_28-66	28	0.2
	66	0
CA_29-30	30	0
CA_29-66, CA_29-66-66	66	0
	66	0
CA_29-70	70	0
CA_30-66, CA_30-66-66	30	0.5
	66	0.4
CA_32-42	42	0.5
CA_32-43	43	0.5
CA_34-39	34	0.2 <sup>1</sup>
	39	0.2 <sup>1</sup>

CA_34-41	34	0.2 <sup>1</sup>
	41	0.2 <sup>1</sup>
CA_38-40, CA_38-40-40	38	0.5 <sup>4</sup>
	40	0.5 <sup>4</sup>
CA_39-40	39	0.3 <sup>4</sup>
	40	0.3 <sup>4</sup>
CA_39-41	39	0.2 <sup>4</sup>
	41	0.2 <sup>4</sup>
CA_39-41	39	0.2 <sup>7</sup>
	41	0.2 <sup>7</sup>
CA_39-42	39	0 <sup>4</sup>
	42	0.5 <sup>4</sup>
CA_39-46	39	0
CA_40-41	40	0 <sup>4</sup>
	41	0 <sup>4</sup>
CA_40-42	40	0.4 <sup>4</sup>
	42	0.5 <sup>4</sup>
CA_40-43	40	0.4 <sup>4</sup>
	43	0.5 <sup>4</sup>
CA_40-46	40	0
CA_41-42,	41	0.4 <sup>4</sup>
CA_41-42-42	42	0.5 <sup>4</sup>
CA_41-42,	41	0 <sup>7</sup>
CA_41-42-42	42	0.5 <sup>7</sup>
CA_41-46	41	0
CA_41-48	41	0 <sup>4</sup>
	48	0.5 <sup>4</sup>
CA_42-43	42	0 <sup>4</sup>
	43	0 <sup>4</sup>
CA_42-46	42	[0]
CA_46-48, CA_46-48-48	48	0.5
CA_46-66, CA_46-66-66	66	0
CA_46-70	70	0
CA_46-71	71	0
CA_48-66, CA_48-48-66, CA_48-66-66, CA_48-48-66- 66	48 66	0.5 0.2
CA_48-71, CA_48-48-71	48 71	0 0
CA_66-70, CA_66-66-70	66 70	0 0
CA_66-71, CA_66-66-71	66 71	0 0
CA_70-71	70	0
	71	0

NOTE 1:	The above additional tolerances are only applicable for the E-UTRA operating bands that belong to the supported inter-band carrier aggregation configurations
NOTE 2:	The above additional tolerances also apply in intra-band and non-aggregated operation for the supported E-UTRA operating bands that belong to the supported inter-band carrier aggregation configurations
NOTE 3:	In case the UE supports more than one of the above 2DL inter-band carrier aggregation configurations and a E-UTRA operating band belongs to more than one 2DL inter-band carrier aggregation configurations then: <ul style="list-style-type: none"> <li>- When the E-UTRA operating band frequency range is <math>\leq 1</math> GHz, the applicable additional tolerance shall be the average of the 2DL tolerances in Table 7.3.1-1A, truncated to one decimal place that would apply for that operating band among the supported 2DL CA configurations. In case there is a harmonic relation between low band UL and high band DL, then the maximum tolerance among the different supported 2DL carrier aggregation configurations involving such band shall be applied</li> <li>- When the E-UTRA operating band frequency range is <math>&gt;1</math> GHz, the applicable additional tolerance shall be the maximum 2DL tolerance in Table 7.3.1-1A that would apply for that operating band among the supported 2DL CA configurations</li> </ul>
NOTE 4:	Only applicable for UE supporting inter-band carrier aggregation with uplink in one E-UTRA band and without simultaneous Rx/Tx.
NOTE 5:	Unless otherwise specified, in case the UE supports more than one of the above 3DL inter-band carrier aggregation configurations and a E-UTRA operating band belongs to more than one 3DL inter-band carrier aggregation configurations then: <ul style="list-style-type: none"> <li>- When the E-UTRA operating band frequency range is <math>\leq 1</math> GHz and the tolerances are the same, the value applies to the band. If the tolerances are different, the applicable additional 3DL tolerance is FFS. In case there is a harmonic relation between low band UL and high band DL, then the maximum tolerance among the different supported 3DL carrier aggregation configurations involving such band shall be applied</li> <li>- When the E-UTRA operating band frequency range is <math>&gt;1</math> GHz, the applicable additional 3DL tolerance shall be the maximum tolerance above that applies for that operating band among the supported 3DL CA configurations.</li> </ul>
NOTE 6:	The above additional tolerances applicable for the E-UTRA operating bands that belong to the supported highest order inter-band carrier aggregation configuration, also applies to the same E-UTRA operating bands that belong to a supported lower order CA configuration.
NOTE 7:	Applicable for UE supporting inter-band carrier aggregation without simultaneous Rx/Tx.
NOTE 8:	Only applicable for UE supporting inter-band carrier aggregation with the uplink active in the FDD band.
NOTE 9:	For Band 28, the requirements only apply for the restricted frequency range specified for this CA configuration (Table 5.5A-2).
NOTE 10:	The requirement is applied for UE transmitting on the frequency range of 2545-2690MHz.
NOTE 11:	The requirement is applied for UE transmitting on the frequency range of 2496-2545MHz.
NOTE 12:	For UE supporting E-UTRA band 42, 43 or 48 and CA configurations including Band 42, 43 or 48, the applicable $\Delta R_{B,c}$ in Band 42, 43, or 48 is the $\max(\text{Band 42 } \Delta R_{B,c}, \text{ Band 43 } \Delta R_{B,c}, \text{ Band 48 } \Delta R_{B,c})$ .
NOTE 13:	Only applicable for UE supporting inter-band carrier aggregation with the uplink active in Band 8.

NOTE: To meet the  $\Delta R_{B,c}$  requirements for CA\_20A-28A state-of-the-art filter combiner technology is needed.

**Table 7.3.1-1B:  $\Delta R_{IB,c}$  (three bands)**



E-UTRA operating band combination	E-UTRA Band	$\Delta R_{IB,c}$ [dB]
CA_1-3-5, CA_1-1-3-5, CA_1-3-3-5	1	0
	3	0
	5	0
CA_1-3-7, CA_1-1-3-7, CA_1-3-3-7, CA_1-3-7-7, CA_1-3-3-7-7	1	0
	3	0
	7	0
CA_1-3-8, CA_1-3-3-8	1	0
	3	0
	8	0
CA_1-3-11	1	0
	3	0.3
	11	0.5
CA_1-3-18	1	0
	3	0
	18	0
CA_1-3-19, CA_1-3-3-19	1	0
	3	0
	19	0
CA_1-3-20, CA_1-3-3-20	1	0
	3	0
	20	0
CA_1-3-21, CA_1-3-3-21	1	0
	3	0.3
	21	0.5
CA_1-3-26	1	0
	3	0
	26	0
CA_1-3-28, CA_1-1-3-28, CA_1-3-3-28, CA_1-1-3-28	1	0
	3	0
	28	0.2
CA_1-3-32	1	0
	3	0
	32	0
CA_1-3-38	1	0
	3	0
	38	0
CA_1-3-40	1	0
	3	0
	40	0
CA_1-3-41	1	0
	3	0
	41	0 <sup>5</sup> /0.5 <sup>6</sup>
CA_1-3-42, CA_1-3-3-42	1	0.2
	3	0.2
	42	0.5
CA_1-3-43	1	0
	3	0
	43	0.5
CA_1-3-46	1	0
	3	0
CA_1-5-7, CA_1-5-7-7	1	0
	5	0
	7	0
CA_1-5-28	1	0
	5	0
	28	0.2
CA_1-5-40	1	0
	5	0
	40	0
CA_1-5-41	1	0
	5	0
	41	0
CA_1-5-46	1	0

	5	0
CA_1-7-8, CA_1-7-7-8	1	0
	7	0
	8	0.2
CA_1-7-20, CA_1-7- 7-20	1	0
	7	0
	20	0
CA_1-7-26, CA_1-7- 7-26	1	0
	7	0
	26	0
CA_1-7-28	1	0
	7	0
	28	0.2
CA_1-7-32	1	0
	7	0
	32	0
CA_1-7-38	1	0
	7	0
	38	0.2
CA_1-7-40	1	0
	7	0.3
	40	0.8
CA_1-7-42	1	0.2
	7	0.2
	42	0.5
CA_1-7-46	1	0
	7	0
	7	0
CA_1-8-11	1	0
	8	0
	11	0
CA_1-8-20	1	0
	8	0
	20	0
CA_1-8-28 <sup>10</sup>	1	0
	8	0.2
	28	0.2
CA_1-8-38	1	0
	8	0
	38	0
CA_1-8-40	1	0
	8	0
	40	0
CA_1-8-42	1	0
	8	0.2
	42	0.5
CA_1-11-18	1	0
	11	0
	18	0
CA_1-11-28	1	0
	11	0
	28	0.2
CA_1-11-42	1	0
	11	0
	42	0.5
CA_1-18-28	1	0
	18	0
	28	0
CA_1-18-41	1	0
	18	0
	41	0
CA_1-18-42	1	0
	18	0
	42	0.5
CA_1-19-21	1	0
	19	0

	21	0
	1	0
CA_1-19-28	19	0
	28	0
CA_1-19-42	1	0
	19	0
	42	0.5
CA_1-20-28	1	0
	20	0.2
	28	0.2
CA_1-20-32	1	0
	20	0
	32	0
CA_1-20-38	1	0
	20	0
	38	0
CA_1-20-42	1	0
	20	0
	42	0.5
CA_1-20-43	1	0
	20	0
	43	0.5
CA_1-21-28	1	0
	21	0
	28	0.2
CA_1-21-42	1	0
	21	0
	42	0.5
CA_1-28-40	1	0
	28	0.2
	40	0
CA_1-28-42	1	0
	28	0.2
	42	0.5
CA_1-32-42	1	0
	42	0.5
CA_1-32-43	1	0
	43	0.5
CA_1-41-42 <sup>7, 12</sup>	1	0
	41	0
	42	0.5
CA_1-42-43 <sup>13</sup>	1	0
	42	0.5
	43	0.5

CA_2-4-5, CA_2-2-4-5, CA_2-4-4-5	2	0.3
	4	0.3
	5	0
CA_2-4-7, CA_2-4-7-7	2	0.3
	4	0.5
	7	0.5
CA_2-4-12, CA_2-2-4-12, CA_2-4-4-12, CA_2-4-12-12	2	0.3
	4	0.3
	12	0.5
CA_2-4-13	2	0.3
	4	0.3
	13	0
CA_2-4-28	2	0.3
	4	0.3
	28	0.5
CA_2-4-29	2	0.3
	4	0.3
CA_2-4-30	2	0.4
	4	0.4
	30	0.5
CA_2-4-71, CA_2-2-4-71	2	0.3
	4	0.3
	71	0
CA_2-5-12, CA_2-2-5-12, CA_2-5-12-12	2	0
	5	0.5
	12	0.3
CA_2-5-7	2	0
	5	0
	7	0
CA_2-5-13	2	0
	5	0
	13	0
CA_2-5-28	2	0
	5	0.5
	28	0.3
CA_2-5-29	2	0
	5	0
CA_2-5-30, CA_2-2-5-30	2	0.4
	5	0
	30	0.5
CA_2-5-46	2	0
	5	0
CA_2-5-66, CA_2-2-5-66, CA_2-5-66-66, CA_2-2-5-66-66	2	0.3
	5	0
	66	0.3
CA_2-7-12, CA_2-2-7-12	2	0
	7	0
	12	0
CA_2-7-13, CA_2-7-7-13	2	0
	7	0
	13	0
CA_2-7-26	2	0
	7	0
	26	0
CA_2-7-28	2	0
	7	0
	28	0
CA_2-7-29, CA_2-7-7-29	2	0
	7	0
CA_2-7-30	2	0.4
	7	0
	30	0.5

CA_2-7-46	2	0
	7	0
CA_2-7-66, CA_2-2-7-66, CA_2-7-7-66, CA_2-7-66-66	2	0.3
	7	0.5
	66	0.5
CA_2-12-30, CA_2-2-12-30	2	0.4
	12	0
	30	0.5
CA_2-12-66, CA_2-2-12-66, CA_2-2-12-66-66, CA_2-12-66-66	2	0.3
	12	0.5
	66	0.3
CA_2-13-46	2	0
	13	0
CA_2-13-48, CA_2-13-48-48	2	0.2
	13	0
	48	0.5
CA_2-13-66, CA_2-2-13-66, CA_2-13-66-66	2	0.3
	13	0
	66	0.3
CA_2-14-30, CA_2-2-14-30	2	0.3
	14	0
	30	0.3
CA_2-14-66, CA_2-2-14-66, CA_2-2-14-66-66, CA_2-14-66-66-66	2	0.3
	14	0
	66	0.3
CA_2-26-66	2	0
	26	0
	66	0
CA_2-28-66	2	0.3
	28	0.2
	66	0.3
CA_2-29-30, CA_2-2-29-30	2	0.4
	30	0.5
CA_2-29-66	2	0.3
	66	0.3
CA_2-30-66, CA_2-2-30-66, CA_2-30-66-66	2	0.4
	30	0.5
	66	0.4
CA_2-46-48	2	0.3
	48	0.5
CA_2-46-66, CA_2-46-46-66, CA_2-46-66-66	2	0
	66	0
CA_2-48-66, CA_2-48-48-66	2	0.3
	48	0.5
	66	0.3
CA_2-66-71, CA_2-2-66-71, CA_2-66-66-71	2	0.3
	66	0.3
	71	0
CA_3-5-7, CA_3-5-7-7, CA_3-3-5-7	3	0
	5	0
	7	0
CA_3-5-28	3	0
CA_3-3-5-28	5	0.1
	28	0.1
CA_3-5-40, CA_3-5-40-40	3	0
	5	0
	40	0
CA_3-5-41	3	0
	5	0
	41	0 <sup>5</sup>
		0,5 <sup>6</sup>
CA_3-7-8, CA_3-3-7-8, CA_3-7-7-8, CA_3-3-7-7-8,	3	0
	7	0
	8	0.2

CA_3-7-20, CA_3-3-7-20, CA_3-7-7-20	3	0
	7	0
	20	0
CA_3-7-26	3	0
	7	0
	26	0
CA_3-7-28, CA_3-3-7-28	3	0
	7	0
	28	0
CA_3-7-32	3	0
	7	0
CA_3-7-38	3	0
	7	0
	38	0.2
CA_3-7-40	3	0
	7	0.3
	40	0.8
CA_3-7-42	3	0.2
	7	0.2
	42	0.5
CA_3-7-46	3	0
	7	0
CA_3-8-11	3	0.3
	8	0
	11	0.5
CA_3-8-20	3	0
	8	0
	20	0
CA_3-8-28 <sup>11</sup>	3	0
	8	0.2
	28	0.1
CA_3-8-32	3	0.3
	8	0
	32	0.5
CA_3-8-38	3	0
	8	0
	38	0
CA_3-8-40	3	0
	8	0
	40	0
CA_3-8-42	3	0.2
	8	0.2
	42	0.5
CA_3-11-18	3	0.3
	11	0.5
CA_3-11-26	18	0
	3	0.3
	11	0.5
CA_3-11-28	26	0
	3	0.3
	11	0.5
CA_3-18-42	28	0.2
	3	0.2
	18	0
CA_3-19-21	42	0.5
	3	0.3
	19	0
CA_3-19-42	21	0.5
	3	0.2
	19	0
CA_3-20-28, CA_3-3-20-28	42	0.5
	3	0
	20	0.1
CA_3-20-32	28	0.1
	3	0

	20	0
	32	0
CA_3-20-42	3	0.2
	20	0
	42	0.5
CA_3-20-43	3	0
	20	0
	43	0.5
CA_3-21-28	3	0.3
	21	0.5
	28	0
CA_3-21-42	3	0.3
	21	0.5
	42	0.5
CA_3-28-38	3	0
	28	0
	38	0.2
CA_3-28-40	3	0
	28	0
	40	0
CA_3-28-41	3	0
	28	0
	41	0 <sup>5</sup> /0.5 <sup>6</sup>
CA_3-28-42, CA_3-28-42-42	3	0.2
	28	0.2
	42	0.5
CA_3-32-42	3	0.2
	32	0
	42	0.5
CA_3-32-43	3	0
	32	0
	43	0.5
CA_3-32-46	3	0
	32	0
CA_3-41-42 <sup>13</sup> CA_3-41-42-42	3	0.5
	41	0 <sup>5</sup> /0.5 <sup>6</sup>
	42	0.5
CA_3-42-43 <sup>13</sup>	3	0.2
	42	0.5
	43	0.5
CA_4-5-12, CA_4-4-5-12, CA_4-5-12-12	4	0
	5	0.5
	12	0.5
CA_4-5-13	4	0
	5	0
	13	0
CA_4-5-29	4	0
	5	0
CA_4-5-30, CA_4-4-5-30	4	0.4
	5	0
	30	0.5
CA_4-7-12	4	0.5
	7	0.5
	12	0.5
CA_4-7-28	4	0.5
	7	0.5
	28	0.2
CA_4-12-30, CA_4-4-12-30	4	0.4
	12	0.5
	30	0.5
CA_4-29-30, CA_4-4-29-30	4	0.4
	30	0.5
CA_5-7-28	5	0
	7	0
	28	0

CA_5-7-46	5	0
	7	0
CA_5-7-66	5	0
	7	0.5
	66	0.5
CA_5-12-46	5	0.5
	12	0.3
CA_5-12-48	5	0.5
	12	0.3
	48	0
CA_5-12-66	5	0
	12	0.5
	66	0.5
CA_5-30-66, CA_5-30-66-66	5	0
	30	0.5
	66	0.4
CA_5-40-41	5	0
	40	0
	41	0
CA_5-46-66, CA_5-46-66-66	5	0
	66	0
	5	0
CA_5-48-66	48	0.5
	66	0.2
	7	0
CA_7-8-20	8	0.2
	20	[0.2]
	7	0
CA_7-8-38	8	0
	38	0.2
	7	0
CA_7-8-40	8	0.2
	40	0.5
	7	0.5
CA_7-12-66	12	0.5
	66	0.5
	7	0.5
CA_7-13-66	13	0
	66	0.5
	7	0
CA_7-20-28	20	0.2
	28	0.2
	7	0
CA_7-20-32	20	0
	32	0
	7	0
CA_7-20-38	20	0
	38	0.2
	7	0
CA_7-20-42	20	0
	42	0.5
	7	0
CA_7-26-66	26	0
	66	0
	7	0
CA_7-28-38	28	0
	38	0.2
	7	0
CA_7-28-40	28	0
	40	0.5
	7	0.5
CA_7-29-66	66	0.5
	7	0.5
CA_7-30-66	30	0.5
	66	0.5
	66	0.5



CA_7-32-46	7	0
	32	0
CA_7-46-66	7	0.5
	66	0.5
CA_8-11-28 <sup>16</sup>	8	0.2
	11	0
	28	0.2
CA_8-11-42	8	0.2
	11	0
	42	0.5
CA_8-20-28	8	0
	20	0
	28	0
CA_8-28-41 <sup>14</sup>	8	0.2
	28	0.1
	41	0
CA_8-39-41	8	0
	39	0.2 <sup>17</sup>
	41	0.2 <sup>17</sup>
CA_12-30-66, CA_12-30-66-66	12	0.5
	30	0.5
	66	0.4
CA_13-46-66	13	0
	66	0
CA_13-48-66, CA_13-48-48-66	13	0
	48	0.5
	66	0.2
CA_14-30-66, CA_14-30-66-66	14	0
	30	0.5
	66	0.4
CA_19-21-42	19	0
	21	0
	42	0.5
CA_20-32-42	20	0
	32	0
	42	0.5
CA_20-32-43	20	0
	32	0
	43	0.5
CA_20-38-40, CA_20-38-40-40 <sup>18</sup>	20	0
	38	0.5
	40	0.5
CA_21-28-42	21	0
	28	0.2
	42	0.5
CA_25-26-41, CA_25-25-26-41	25	0
	26	0
	41	0.5
CA_28-41-42 <sup>9</sup> , CA_28-41-42-42 <sup>9</sup>	28	0.2
	41	0.4 <sup>1</sup>
	42	0.5 <sup>1</sup>
CA_29-30-66, CA_29-30-66-66	30	0.5
	66	0.4
	CA_29-46-66	66
CA_29-66-70, CA_29-66-66-70	66	0
	70	0
	CA_32-42-43 <sup>13</sup>	32
CA_32-42-43 <sup>13</sup>	42	0.5
	43	0.5

CA_46-48-66	48	0,5
	66	0,3
CA_46-48-71, CA_46-48-48-71	46	0
	48	0,5
	71	0
CA_66-70-71, CA_66-66-70-71	66	0
	70	0
	71	0
NOTE 1: The above additional tolerances are only applicable for the E-UTRA operating bands that belong to the supported inter-band carrier aggregation configurations.		
NOTE 2: The above additional tolerances also apply in intra-band and non-aggregated operation for the supported E-UTRA operating bands that belong to the supported inter-band carrier aggregation configurations.		
NOTE 3: Unless otherwise specified, in case the UE supports more than one of the above 3DL inter-band carrier aggregation configurations and a E-UTRA operating band belongs to more than one 3DL inter-band carrier aggregation configurations then: <ul style="list-style-type: none"> <li>- When the E-UTRA operating band frequency range is <math>\leq 1</math>GHz and the tolerances are the same, the value applies to the band. If the tolerances are different, the applicable additional 3DL tolerance is FFS. In case there is a harmonic relation between low band UL and high band DL, then the maximum tolerance among the different supported 3DL carrier aggregation configurations involving such band shall be applied</li> <li>- When the E-UTRA operating band frequency range is <math>&gt;1</math>GHz, the applicable additional 3DL tolerance shall be the maximum tolerance above that applies for that operating band among the supported 3DL CA configurations.</li> </ul>		
NOTE 4: The above additional tolerances applicable for the E-UTRA operating bands that belong to the supported highest order inter-band carrier aggregation configuration, also applies to the same E-UTRA operating bands that belong to a supported lower order CA configuration.		
NOTE 5: The requirement is specified for the frequency range of 2545-2690MHz.		
NOTE 6: The requirement is specified for the frequency range of 2496-2545MHz.		
NOTE 7: Only applicable for UE supporting inter-band carrier aggregation with the uplink active in Band 1 or Band 42.		
NOTE 8: Only applicable for UE supporting inter-band carrier aggregation with uplink in one E-UTRA band and without simultaneous Rx/Tx on Band 41 and Band 42.		
NOTE 9: Applicable for UE supporting inter-band carrier aggregation without simultaneous Rx/Tx among TDD bands.		
NOTE 10: Only applicable for UE supporting inter-band carrier aggregation with the uplink active in Band 1 or Band 8.		
NOTE 11: Only applicable for UE supporting inter-band carrier aggregation with the uplink active in Band 3 or Band 8.		
NOTE 12: Applicable for UE supporting inter-band carrier aggregation without simultaneous Rx/Tx among TDD bands.		
NOTE 13: Applicable for UE supporting inter-band carrier aggregation without simultaneous Rx/Tx among TDD bands.		
NOTE 14: Only applicable for UE supporting inter-band carrier aggregation with the uplink active in Band 8 or Band 41.		
NOTE 15: For UE supporting E-UTRA band 42, 43 or 48 and CA configurations including Band 42, 43 or 48, the applicable $\Delta R_{B,c}$ in Band 42, 43, or 48 is the $\max(\text{Band 42 } \Delta R_{B,c}, \text{Band 43 } \Delta R_{B,c}, \text{Band 48 } \Delta R_{B,c})$ .		
NOTE 16: Only applicable for UE supporting inter-band carrier aggregation with the uplink active in Band 8 or Band 11.		
NOTE 17: Only applicable for UE supporting inter-band carrier aggregation with uplink in one E-UTRA band and without simultaneous Rx/Tx on Band 39 and Band 41.		
NOTE 18: Only applicable for UE supporting inter-band carrier aggregation with uplink in one E-UTRA band and without simultaneous Rx/Tx among TDD bands.		

Table 7.3.1-1C:  $\Delta R_{B,c}$  (four bands)

E-UTRA operating band combination	E-UTRA Band	$\Delta R_{B,c}$ [dB]
CA_1-3-5-7, CA_1-3-3-5-7, CA_1-3-5-7-7	1	0
	3	0
	5	0
	7	0
CA_1-3-5-28	1	0
	3	0
	5	0.1
	28	0.2
CA_1-3-5-40	1	0
	3	0
	5	0
	40	0
CA_1-3-5-41	1	0
	3	0
	5	0
	41	0 <sup>6</sup> 0.5 <sup>7</sup>
CA_1-3-7-8, CA_1-3-3-7-8, CA_1-3-7-7-8, CA_1-3-3-7-7-8	1	0
	3	0
	7	0
	8	0.2
CA_1-3-7-20, CA_1-3-3-7-20, CA_1-3-7-7-20	1	0
	3	0
	7	0
	20	0
CA_1-3-7-26, CA_1-3-7-7-26	1	0
	3	0
	7	0
	26	0
CA_1-3-7-28, CA_1-1-3-7-28, CA_1-1-3-3-7-28, CA_1-3-3-7-28, CA_1-3-7-7-28	1	0
	3	0
	7	0
	28	0.2
CA_1-3-7-32	1	0
	3	0
	7	0
	32	0
CA_1-3-7-38	1	0
	3	0
	7	0
	38	0
CA_1-3-7-40	1	0
	3	0
	7	0.3
	40	0.8
CA_1-3-7-42	1	0.3
	3	0.3
	7	0.3
	42	0.5
CA_1-3-7-46	1	0
	3	0
	7	0
	46	0
CA_1-3-8-11	1	0
	3	0.3
	8	0
	11	0.5
CA_1-3-8-20	1	0
	3	0
	8	0
	20	0

CA_1-3-8-28 <sup>8</sup>	1	0
	3	0
	8	0.2
	28	0.2
CA_1-3-8-38	1	0
	3	0
	8	0
	38	0
CA_1-3-11-28	1	0
	3	0.3
	11	0.5
	28	0.2
CA_1-3-8-40	1	0
	3	0
	8	0
	40	0
CA_1-3-8-42	1	0.2
	3	0.2
	8	0.2
	42	0.5
CA_1-3-18-42	1	0.2
	3	0.2
	18	0
	42	0.5
CA_1-3-19-21	1	0
	3	0.3
	19	0
	21	0.5
CA_1-3-19-42, CA_1-3-3-19-21	1	0.2
	3	0.2
	19	0
	42	0.5
CA_1-3-20-28, CA_1-3-3-20-28	1	0
	3	0
	20	0.2
	28	0.2
CA_1-3-20-32	1	0
	3	0
	20	0
	32	0
CA_1-3-20-42	1	0.2
	3	0.2
	20	0
	42	0.5
CA_1-3-20-43	1	0
	3	0
	20	0
	43	0.5

CA_1-3-21-28	1	0
	3	0.3
	21	0.5
	28	0.2
CA_1-3-21-42	1	0.2
	3	0.3
	21	0.5
	42	0.5
CA_1-3-28-40	1	0
	3	0
	28	0.2
	40	0
CA_1-3-28-42	1	0.2
	3	0.2
	28	0.2
	42	0.5
CA_1-3-32-42	1	0.2
	3	0.2
	32	0
	42	0.5
CA_1-3-32-43	1	0
	3	0
	32	0
	43	0.5
CA_1-3-41-42	1	0.2
	3	0.2
	41	0
	42	0.5
CA_1-3-42-43 <sup>11</sup>	1	0.2
	3	0.2
	42	0.5
	43	0.5
CA_1-5-7-28	1	0
	5	0.1
	7	0
	28	0.2

CA_1-5-7-46	1	0
	5	0
	7	0
CA_1-7-8-20	1	0
	7	0
	8	0.2
	20	0.2
CA_1-7-8-40	1	0
	7	0.3
	8	0.2
CA_1-7-8-40	40	0.8
	1	0
	7	0
CA_1-7-20-28	20	0.2
	28	0.2
	1	0
CA_1-7-20-32	7	0
	20	0
	32	0
	1	0.2
CA_1-7-20-42	7	0.2
	20	0.2
	42	0.5
	1	0
CA_1-7-28-40	7	0.3
	28	0.2
	40	0.8
	1	0
CA_1-8-11-28 <sup>9</sup>	8	0.2
	11	0
	28	0.2
CA_1-8-11-42	1	0
	8	0.2
	11	0
	42	0.5
CA_1-8-20-28	1	0
	8	0.2
	20	0.2
	28	0.2
CA_1-19-21-42	1	0
	19	0
	21	0
	42	0.5
CA_1-20-32-42	1	0
	20	0
	32	0
	42	0.5
CA_1-20-32-43	1	0
	20	0
	32	0
	43	0.5
CA_1-21-28-42	1	0
	21	0
	28	0.2
	42	0.5
CA_1-32-42-43 <sup>11</sup>	1	0
	32	0
	42	0.5
	43	0.5

CA_2-4-5-12	2	0.3
	4	0.3
	5	0.5
	12	0.5
CA_2-4-5-29	2	0.3
	4	0.3
	5	0
	30	0.5
CA_2-4-5-30	2	0.4
	4	0.4
	5	0
	30	0.5
CA_2-4-7-12	2	0.3
	4	0.3
	7	0.5
	12	0.5
CA_2-4-12-30	2	0.4
	4	0.4
	12	0.5
	30	0.5
CA_2-4-29-30	2	0.4
	4	0.4
	30	0.5
	66	0.5
CA_2-5-7-28	2	0
	5	0.2
	7	0
	28	0.2
CA_2-5-12-66, CA_2-2-5-12-66	2	0.3
	5	0.5
	12	0.5
	66	0.3
CA_2-5-30-66, CA_2-2-5-30-66, CA_2-5-30-66-66	2	0.4
	5	0
	30	0.5
	66	0.4
CA_2-5-46-66, CA_2-5-46-66-66	2	0.3
	5	0
	66	0.3
	66	0.3
CA_2-7-12-66, CA_2-2-7-12-66	2	0.3
	7	0.5
	12	0.5
	66	0.3
CA_2-7-13-66	2	0.3
	7	0.5
	13	0
	66	0.5
CA_2-7-26-66	2	0.3
	7	0.5
	26	0
	66	0.5
CA_2-7-29-66, CA_2-7-7-29-66	2	0.3
	7	0.5
	66	0.5
CA_2-7-46-66	2	0.3
	7	0.5
	46	0
	66	0.5

CA_2-12-30-66, CA_2-2-12-30-66, CA_2-12-30-66-66	2	0.4
	12	0.5
	30	0.5
	66	0.4
CA_2-13-46-66, CA_2-13-46-66-66	2	0.3
	13	0
	66	0.3
CA_2-13-48-66, CA_2-13-48-48-66	2	0.3
	13	0
	48	0.5
	66	0.3
CA_2-14-30-66, CA_2-2-14-30-66, CA_2-14-30-66-66	2	0.4
	14	0
	30	0.5
	66	0.4
CA_2-29-30-66	2	0.4
	30	0.5
	66	0.4
CA_2-46-48-66	2	0.3
	48	0.5
	66	0.3
CA_3-5-7-28, CA_3- 3-5-7-28	3	0
	5	0.1
	7	0
	28	0.1
CA_3-7-8-20	3	0
	7	0
	8	0
	20	0
CA_3-7-8-38	3	0
	7	0
	8	0
	38	0.2
CA_3-7-8-40	3	0
	7	0.3
	8	0.2
	40	0.8
CA_3-7-20-28	3	0
	7	0
	20	0.2
	28	0.1
CA_3-7-20-32	3	0
	7	0
	20	0
	32	0
CA_3-7-20-42	3	0.2
	7	0.2
	20	0
	42	0.5
CA_3-7-28-38	3	0
	7	0
	28	0
	38	0.2
CA_3-7-28-40	3	0
	7	0.3
	28	0
	40	0.8
CA_3-7-32-46	3	0
	7	0
	32	0



CA_3-8-11-28 <sup>10</sup>	3	0.3
	8	0.2
	11	0.5
	28	0.2
CA_3-8-20-28	3	0
	8	0.2
	20	0.1
	28	0.1
CA_3-19-21-42	3	0.3
	19	0
	21	0.5
	42	0.5
CA_3-20-32-42	3	0.2
	20	0
	32	0
	42	0.5
CA_3-20-32-43	3	0
	20	0
	32	0
	43	0.5
CA_3-21-28-42	3	0.3
	21	0.5
	28	0.2
	42	0.5
CA_3-28-41-42	3	0.5
	28	0.2
	41	0.4 <sup>9</sup> /0.5 <sup>7</sup>
	42	0.5
CA_3-32-42-43 <sup>11</sup>	3	0.2
	32	0
	42	0.5
	43	0.5

NOTE 1: The above additional tolerances are only applicable for the E-UTRA operating bands that belong to the supported inter-band carrier aggregation configurations.

NOTE 2: The above additional tolerances also apply in intra-band and non-aggregated operation for the supported E-UTRA operating bands that belong to the supported inter-band carrier aggregation configurations.

NOTE 3: Tolerances for a UE supporting multiple 4DL inter-band CA configurations are FFS.

NOTE 4: The above additional tolerances applicable for the E-UTRA operating bands that belong to the supported highest order inter-band carrier aggregation configuration, also applies to the same E-UTRA operating bands that belong to a supported lower order CA configuration.

NOTE 5: For UE supporting E-UTRA band 42, 43 or 48 and CA configurations including Band 42, 43 or 48, the applicable  $\Delta R_{IB,c}$  in Band 42, 43, or 48 is the  $\max(\text{Band 42 } \Delta R_{IB,c}, \text{Band 43 } \Delta R_{IB,c}, \text{Band 48 } \Delta R_{IB,c})$ .

NOTE 6: The requirement is applied for UE transmitting on the frequency range of 2545-2690MHz.

NOTE 7: The requirement is applied for UE transmitting on the frequency range of 2496-2545MHz.

NOTE 8: Only applicable for UE supporting inter-band carrier aggregation with the uplink active in Band 1, Band 3 or Band 8.

NOTE 9: Only applicable for UE supporting inter-band carrier aggregation with the uplink active in Band 1, Band 8 or Band 11.

NOTE 10: Only applicable for UE supporting inter-band carrier aggregation with the uplink active in Band 3, Band 8 or Band 11.

NOTE 11: Applicable for UE supporting inter-band carrier aggregation without simultaneous Rx/Tx among TDD bands.

Table 7.3.1-1D:  $\Delta R_{IB,c}$  (five bands)

E-UTRA operating band combination	E-UTRA Band	$\Delta R_{IB,c}$ [dB]
CA_1-3-5-7-28	1	0
	3	0
	5	0.1
	7	0
	28	0.2
CA_1-3-7-8-20	1	0
	3	0
	7	0
	8	0.2
	20	0.2
CA_1-3-7-20-28	1	0
	3	0
	7	0
	20	0.2
CA_1-3-7-20-32	28	0.2
	1	0
	3	0
	7	0
CA_1-3-7-20-42	20	0
	28	0.2
	1	0.2
	3	0.2
	7	0.2
CA_1-3-8-11-28	20	0
	42	0.5
	1	0
	3	0.3
	8	0.2
CA_1-3-20-32-42	11	0.5
	28	0.2
	1	0.2
	3	0.2
	20	0
CA_1-3-20-32-43	32	0
	42	0.5
	1	0
	3	0
	20	0
CA_1-3-32-42-43	32	0
	43	0.5
	1	0.2
	3	0.2
	32	0
CA_1-3-32-42-43	42	0.5
	43	0.5
	1	0.2
	3	0.2

NOTE 1: The above additional tolerances are only applicable for the E-UTRA operating bands that belong to the supported inter-band carrier aggregation configurations.

NOTE 2: The above additional tolerances also apply in intra-band and non-aggregated operation for the supported E-UTRA operating bands that belong to the supported inter-band carrier aggregation configurations.

NOTE 3: Tolerances for a UE supporting multiple 5DL inter-band CA configurations are FFS.

NOTE 4: The above additional tolerances applicable for the E-UTRA operating bands that belong to the supported highest order inter-band carrier aggregation configuration, also applies to the same E-UTRA operating bands that belong to a supported lower order CA configuration.

NOTE : The above additional tolerances do not apply to supported UTRA operating bands with frequency range below 1 GHz that correspond to the E-UTRA operating bands that belong to the supported inter-band carrier aggregation configurations when such bands are belonging only to band combination(s) where one band is <1GHz and other bands are >1.7GHz and there is no harmonic relationship between the low band UL and high band DL. Otherwise the above additional tolerances also apply to supported UTRA operating bands that correspond to the E-UTRA operating bands that belong to the supported inter-band carrier aggregation configurations.

**Table 7.3.1-2: Uplink configuration for reference sensitivity**

E-UTRA Band / Channel bandwidth / N <sub>RB</sub> / Duplex mode							
E-UTRA Band	1.4 MHz	3 MHz	5 MHz	10 MHz	15 MHz	20 MHz	Duplex Mode
1			25	50	75	100	FDD
2	6	15	25	50	50 <sup>1</sup>	50 <sup>1</sup>	FDD
3	6	15	25	50	50 <sup>1</sup>	50 <sup>1</sup>	FDD
4	6	15	25	50	75	100	FDD
5	6	15	25	25 <sup>1</sup>			FDD
6			25	25 <sup>1</sup>			FDD
7			25	50	75	75 <sup>1</sup>	FDD
8	6	15	25	25 <sup>1</sup>			FDD
9			25	50	50 <sup>1</sup>	50 <sup>1</sup>	FDD
10			25	50	75	100	FDD
11			25	25 <sup>1</sup>			FDD
12	6	15	20 <sup>1</sup>	20 <sup>1</sup>			FDD
13			20 <sup>1</sup>	20 <sup>1</sup>			FDD
14			15 <sup>1</sup>	15 <sup>1</sup>			FDD
...							
17			20 <sup>1</sup>	20 <sup>1</sup>			FDD
18			25	25 <sup>1</sup>	25 <sup>1</sup>		FDD
19			25	25 <sup>1</sup>	25 <sup>1</sup>		FDD
20			25	20 <sup>1</sup>	20 <sup>3</sup>	20 <sup>3</sup>	FDD
21			25	25 <sup>1</sup>	25 <sup>1</sup>		FDD
22			25	50	50 <sup>1</sup>	50 <sup>1</sup>	FDD
23	6	15	25	50	75	100	FDD
24			25	50			FDD
25	6	15	25	50	50 <sup>1</sup>	50 <sup>1</sup>	FDD
26	6	15	25	25 <sup>1</sup>	25 <sup>1</sup>		FDD
27	6	15	25	25 <sup>1</sup>			FDD
28		15	25	25 <sup>1</sup>	25 <sup>1</sup>	25 <sup>1</sup>	FDD
30			25	25 <sup>1</sup>			FDD
31	6	5 <sup>4</sup>	5 <sup>4</sup>				FDD
...							
33			25	50	75	100	TDD
34			25	50	75		TDD
35	6	15	25	50	75	100	TDD
36	6	15	25	50	75	100	TDD
37			25	50	75	100	TDD
38			25	50	75	100	TDD
39			25	50	75	100	TDD
40			25	50	75	100	TDD
41			25	50	75	100	TDD
42			25	50	75	100	TDD
43			25	50	75	100	TDD
44		15	25	50	75	100	TDD
45			25	50	75	100	TDD
50		15	25	50	75	100	TDD
51		15	25				TDD
52			25	50	75	100	TDD
53	6	15	25	50			
...							
65	6	15	25	50	75	100	FDD
66	6	15	25	50	75	100	FDD
68			25	25 <sup>1</sup>	25 <sup>1</sup>		FDD

...							
70			25	50	75		FDD
71			25	25 <sup>1</sup>	20 <sup>1</sup>	20 <sup>1</sup>	FDD
72	6	5 <sup>4</sup>	5 <sup>4</sup>				FDD
73	6	5 <sup>4</sup>	5 <sup>4</sup>				FDD
74	6	15	25	25 <sup>1</sup>	25 <sup>1</sup>	25 <sup>1</sup>	FDD
85			20 <sup>1</sup>	20 <sup>1</sup>			FDD
87	6	5 <sup>4</sup>	5 <sup>4</sup>				FDD
88	6	5 <sup>4</sup>	5 <sup>4</sup>				FDD
NOTE 1: <sup>1</sup> refers to the UL resource blocks shall be located as close as possible to the downlink operating band but confined within the transmission bandwidth configuration for the channel bandwidth (Table 5.6-1).							
NOTE 2: For the UE which supports both Band 11 and Band 21 the uplink configuration for reference sensitivity is FFS.							
NOTE 3: <sup>3</sup> refers to Band 20; in the case of 15MHz channel bandwidth, the UL resource blocks shall be located at RB <sub>start</sub> 11 and in the case of 20MHz channel bandwidth, the UL resource blocks shall be located at RB <sub>start</sub> 16							
NOTE 4: <sup>4</sup> refers to Bands 31, 72, 73, 87 and 88; in the case of 3 MHz channel bandwidth, the UL resource blocks shall be located at RB <sub>start</sub> 9 and in the case of 5 MHz channel bandwidth, the UL resource blocks shall be located at RB <sub>start</sub> 10.							

Unless given by Table 7.3.1-3, the minimum requirements specified in Tables 7.3.1-1, 7.3.1-1a and 7.3.1-2 shall be verified with the network signalling value NS\_01 (Table 6.2.4-1) configured.

**Table 7.3.1-3: Network signalling value for reference sensitivity**

E-UTRA Band	Network Signalling value
2	NS_03
4	NS_03
10	NS_03
12	NS_06
13	NS_06
14	NS_06
17	NS_06
19	NS_08
21	NS_09
23	NS_03
25	NS_03
30	NS_21
48	NS_27
53	NS_45
66	NS_03
70	NS_03
71	NS_35
85	NS_06

### 7.3.1A Minimum requirements (QPSK) for CA

For inter-band carrier aggregation with one component carrier per operating band and the uplink assigned to one E-UTRA band the throughput shall be  $\geq 95\%$  of the maximum throughput of the reference measurement channels as specified in Annexes A.2.2, A.2.3 and A.3.2 (with one sided dynamic OCNG Pattern OP.1 FDD/TDD for the DL-signal as described in Annex A.5.1.1/A.5.2.1) with parameters specified in Table 7.3.1-1, Table 7.3.1-1a and Table 7.3.1-2. The reference sensitivity is defined to be met with all downlink component carriers active and one of the uplink carriers active. The uplink resource blocks shall be located as close as possible to the primary downlink operating band but confined within the transmission bandwidth configuration for the channel bandwidth (Table 5.6-1). The primary downlink operating band is the downlink band of the active uplink operating band. The UE shall meet the requirements specified in subclause 7.3.1 with the following exceptions.

For the bands supporting 4 antenna ports which are in Table 7.3.1-1a, the minimum requirements for reference sensitivity in the reference sensitivity exception tables shall be modified by the amount given in  $\Delta R_{IB,4R}$  in Table 7.3.1-1a for the applicable E-UTRA bands unless otherwise specified.

For the bands supporting 8 antenna ports which are in Table 7.3.1-1aa, the minimum requirements for reference sensitivity in the reference sensitivity exception tables shall be modified by the amount given in  $\Delta R_{IB,8R}$  in Table 7.3.1-1aa for the applicable E-UTRA bands unless otherwise specified.

For the UE that supports any of the E-UTRA CA configurations given in Table 7.3.1A-0a, exceptions to the requirements for a band(s) specified in subclause 7.3.1 are allowed when the band(s) is impacted by harmonic interference from the uplink transmission in a lower-frequency band of the same CA configuration. For these exceptions, the UE shall meet the requirements specified in Table 7.3.1A-0a and Table 7.3.1A-0b.

**Table 7.3.1A-0a: Reference sensitivity for carrier aggregation QPSK  $P_{\text{REFSENS, CA}}$  (exceptions due to harmonic issue)**



Channel bandwidth								
EUTRA CA Configuration	EUTRA band	1.4 MHz (dBm)	3 MHz (dBm)	5 MHz (dBm)	10 MHz (dBm)	15 MHz (dBm)	20 MHz (dBm)	Duplex mode
CA_1A-3A-5A-7A-28A <sup>5,6</sup>	1 <sup>33</sup>			-89.8	-89.4	-89	-88.7	FDD
CA_1A-3A-5A-28A <sup>5,6</sup>	1 <sup>33</sup>			-89.8	-89.4	-89	-88.7	FDD
CA_1A-3A-5A-41A <sup>8,19,28</sup>	5			N/A	N/A			FDD
	41			N/A	N/A	N/A	N/A	TDD
CA_1A-3A-7A-8A <sup>4</sup>	3			N/A	N/A	N/A	N/A	FDD
CA_1A-3A-7A-8A <sup>4,5,6</sup>	7 <sup>33</sup>			-88	-87.4	-87	-86.7	FDD
CA_1A-3C-7A-8A <sup>4</sup>	3			N/A	N/A	N/A	N/A	FDD
CA_1A-3C-7A-8A <sup>5,6</sup>	7 <sup>33</sup>			-88	-87.4	-87	-86.7	FDD
CA_1A-3A-7A-8A-20A <sup>5,6</sup>	3			N/A	N/A	N/A	N/A	FDD
CA_1A-3A-7A-8A-20A <sup>5,6</sup>	7 <sup>33</sup>			-88	-87.4	-87	-86.7	FDD
CA_1A-3A-7A-20A-28A <sup>5,6</sup>	1 <sup>33</sup>			-89.8	-89.4	-89	-88.7	FDD
CA_1A-3A-7A-20A-42A <sup>9,10</sup>	42 <sup>33</sup>			-71.7	-71.7	-71.7	-71.7	TDD
CA_1A-3A-7A-20A-42A <sup>11</sup>	42 <sup>33</sup>			-97.1	-94.7	-93.2	-92.5	TDD
CA_1A-3A-7A-28A <sup>5,6</sup>	1 <sup>33</sup>			-89.8	-89.4	-89	-88.7	FDD
CA_1A-3A-7A-42A <sup>9,10</sup>	42 <sup>33</sup>			-71.7	-71.7	-71.7	-71.7	TDD
CA_1A-3A-7A-42A <sup>11</sup>	42 <sup>33</sup>			-97.1	-94.7	-93.2	-92.5	TDD
CA_1A-3A-8A <sup>4</sup>	3			N/A	N/A	N/A	N/A	FDD
CA_1A-3A-8A-11A <sup>4</sup>	3			N/A	N/A	N/A	N/A	FDD
CA_1A-3A-8A-20A <sup>4</sup>	3			N/A	N/A	N/A	N/A	FDD
CA_1A-3A-8A-11A-28A <sup>4</sup>	3			N/A	N/A	N/A	N/A	FDD
CA_1A-3A-8A-28A <sup>4</sup>	3			N/A	N/A	N/A	N/A	FDD
CA_1A-3A-8A-38A <sup>4</sup>	3			N/A	N/A	N/A	N/A	FDD
CA_1A-3A-11A-28A <sup>5,6</sup>	1 <sup>33</sup>			-89.8	-89.4	-89	-88.7	FDD
CA_1A-3A-11A-28A <sup>9,10</sup>	11			-75.2	-75.2			FDD
CA_1A-3A-8A-40A <sup>4</sup>	3			N/A	N/A	N/A	N/A	FDD
CA_1A-3A-8A-42A <sup>4</sup>	3			N/A	N/A	N/A	N/A	FDD
CA_1A-3A-8A-42A <sup>9,10</sup>	42 <sup>33</sup>			-71.7	-71.7	-71.7	-71.7	TDD
CA_1A-3A-8A-42A <sup>11</sup>	42 <sup>33</sup>			-97.1	-94.7	-93.2	-92.5	TDD
CA_1A-3A-8A-42A <sup>12,13</sup>	42 <sup>33</sup>			-84.8	-84.7	-84.6	-84.5	TDD
CA_1A-3A-18A-42A <sup>9,10</sup>	42 <sup>33</sup>			-71.7	-71.7	-71.7	-71.7	TDD
CA_1A-3A-18A-42A <sup>11</sup>	42 <sup>33</sup>			-97.1	-94.7	-93.2	-92.5	TDD
CA_1A-3A-19A-42A <sup>9,10</sup>	42 <sup>33</sup>			-71.7	-71.7	-71.7	-71.7	TDD
CA_1A-3A-19A-42A <sup>11</sup>	42			-97.1	-94.7	-93.2	-92.5	TDD
CA_1A-3A-20A-28A <sup>5,6</sup>	1 <sup>33</sup>			-89.8	-89.4	-89	-88.7	FDD
CA_1A-3A-20A-32A-42A <sup>9,10</sup>	42 <sup>33</sup>			-71.7	-71.7	-71.7	-71.7	TDD
CA_1A-3A-20A-32A-42A <sup>11</sup>	42 <sup>33</sup>			-97.1	-94.7	-93.2	-92.5	TDD
CA_1A-3A-20A-32A-42A <sup>12,13</sup>	42 <sup>33</sup>			-84.8	-84.7	-84.6	-84.5	TDD
CA_1A-3A-21A-28A <sup>4,21</sup>	21			N/A	N/A	N/A		FDD
CA_1A-3A-21A-42A <sup>22,23</sup>	42 <sup>33</sup>			-71.7	-71.7	-71.7	-71.7	TDD
CA_1A-3A-21A-42A <sup>24</sup>	42 <sup>33</sup>			-97.1	-94.7	-93.2	-92.5	TDD
CA_1A-3A-28A-40A <sup>15,16</sup>	28			-60.7	-60.7	-60.7	-60.7	FDD
CA_1A-3A-28A-42A <sup>22,23</sup>	42 <sup>33</sup>			-71.7	-71.7	-71.7	-71.7	TDD
CA_1A-3A-28A-42A <sup>24</sup>	42 <sup>33</sup>			-97.1	-94.7	-93.2	-92.5	TDD

CA_1A-3A-28A <sup>5,6</sup> CA_1A-1A-3A-28A CA_1A-1A-3C-28A CA_1A-3A-3A-28A	1 <sup>33</sup>			-89.8	-89.4	-89	-88.7	FDD
CA_1A-3A-32A-42A <sup>9,10</sup>	42 <sup>33</sup>			-71.7	-71.7	-71.7	-71.7	TDD
CA_1A-3A-32A-42A <sup>11</sup>	42 <sup>33</sup>			-97.1	-94.7	-93.2	-92.5	TDD
CA_1A-3A-42A-43A <sup>9,10</sup>	42 <sup>33</sup>			-71.7	-71.7	-71.7	-71.7	TDD
CA_1A-3A-42A-43A <sup>11</sup>	42 <sup>33</sup>			-97.1	-94.7	-93.2	-92.5	TDD
CA_1A-3A-32A-42A-43A <sup>9,10</sup>	42 <sup>33</sup>			-71.7	-71.7	-71.7	-71.7	TDD
CA_1A-3A-32A-42A-43A <sup>11</sup>	42 <sup>33</sup>			-97.1	-94.7	-93.2	-92.5	TDD
CA_1A-3A-41A-42A <sup>9,10</sup>	42 <sup>33</sup>			-71.7	-71.7	-71.7	-71.7	TDD
CA_1A-3A-41A-42A <sup>11</sup>	42 <sup>33</sup>			-97.1	-94.7	-93.2	-92.5	TDD
CA_1A-3A-42A <sup>9,10</sup>	42 <sup>33</sup>			-71.7	-71.7	-71.7	-71.7	TDD
CA_1A-3A-42A <sup>11</sup>	42 <sup>33</sup>			-97.1	-94.7	-93.2	-92.5	TDD
CA_1A-3A-3A-42A <sup>9,10</sup>	42 <sup>33</sup>			-71.7	-71.7	-71.7	-71.7	TDD
CA_1A-3A-3A-42A <sup>11</sup>	42 <sup>33</sup>			-97.1	-94.7	-93.2	-92.5	TDD
CA_1A-3A-42A-42A <sup>9,10</sup>	42 <sup>33</sup>			-71.7	-71.7	-71.7	-71.7	TDD
CA_1A-3A-42A-42A <sup>11</sup>	42 <sup>33</sup>			-97.1	-94.7	-93.2	-92.5	TDD
CA_1A-3A-42A-42C <sup>9,10</sup>	42 <sup>33</sup>			-71.7	-71.7	-71.7	-71.7	TDD
CA_1A-3A-42A-42C <sup>11</sup>	42 <sup>33</sup>			-97.1	-94.7	-93.2	-92.5	TDD
CA_1A-3A-42C-42C <sup>9,10</sup>	42 <sup>33</sup>			-71.7	-71.7	-71.7	-71.7	TDD
CA_1A-3A-42C-42C <sup>11</sup>	42 <sup>33</sup>			-97.1	-94.7	-93.2	-92.5	TDD
CA_1A-5A-7A-28A <sup>5,6</sup>	1 <sup>33</sup>			-89.8	-89.4	-89	-88.7	FDD
CA_1A-5A-28A <sup>5,6</sup>	1 <sup>33</sup>			-89.8	-89.4	-89	-88.7	FDD
CA_1A-5A-41A <sup>8,19</sup>	5			N/A	N/A	N/A	N/A	FDD
	41			N/A	N/A	N/A	N/A	TDD
CA_1A-7A-8A <sup>5,6</sup> CA_1A-7A-7A-8A <sup>5,6</sup>	7 <sup>33</sup>			-88	-87.4	-87	-86.7	FDD
CA_1A-7A-8A-20A	1 <sup>33</sup>			-89.8	-89.4	-89	-88.7	FDD
CA_1A-7A-8A-40A <sup>5,6</sup>	7 <sup>33</sup>				-87.1	-86.7	-86.4	FDD
CA_1A-7A-20A-28A <sup>5,6</sup>	1 <sup>33</sup>			-89.8	-89.4	-89	-88.7	FDD
CA_1A-7A-28A <sup>5,6</sup>	1 <sup>33</sup>			-89.8	-89.4	-89	-88.7	FDD
CA_1A-7A-28A-40A <sup>15,16</sup>	28			-60.7	-60.7	-60.7	-60.7	FDD
CA_1A-8A-20A-28A <sup>5,6</sup>	1 <sup>33</sup>			-89.8	-89.4	-89	-88.7	FDD
CA_1A-8A-42A <sup>12,13</sup> CA_1A-8A-42C <sup>12,13</sup>	42 <sup>33</sup>			-84.8	-84.7	-84.6	-84.5	TDD
CA_1A-8A-11A-42A <sup>12,13</sup>	42 <sup>33</sup>			-84.8	-84.7	-84.6	-84.5	TDD
CA_1A-11A-28A <sup>5,6</sup>	1 <sup>33</sup>			-89.8	-89.4	-89	-88.7	FDD
CA_1A-11A-28A <sup>9,10</sup>	11			-75.2	-75.2			FDD
CA_1A-18A-28A <sup>14</sup>	1			N/A	N/A	N/A	N/A	FDD
CA_1A-19A-28A <sup>14</sup>	1 <sup>33</sup>			N/A	N/A	N/A	N/A	FDD
CA_1A-20A-28A	1 <sup>33</sup>			-89.8	-89.4	-89	-88.7	FDD
CA_1A-20A-32A-42A <sup>12,13</sup>	42 <sup>33</sup>			-84.8	-84.7	-84.6	-84.5	TDD
CA_1A-21A-28A <sup>4,21</sup>	21			N/A	N/A	N/A		FDD
CA_1A-21A-28A-42A <sup>4,21</sup>	21			N/A	N/A	N/A		FDD
CA_1A-28A <sup>5,6,14</sup>	1 <sup>33</sup>			-89.8	-89.4	-89	-88.7	FDD
CA_1A-1A-28A <sup>5,6,14</sup>	1			-89.8	-89.4	-89	-88.7	FDD
CA_1A-28A-40A <sup>15,16</sup> CA_1A-28A-40C <sup>15,16</sup>	28			-60.7	-60.7	-60.7	-60.7	FDD
CA_1A-28A-40A <sup>5,6</sup> CA_1A-28A-40C <sup>5,6</sup>	1 <sup>33</sup>			-89.8	-89.4	-89	-88.7	FDD
CA_1A-28A-42A <sup>5,6,17,18</sup>	1 <sup>33</sup>			-89.8	-89.4	-89	-88.7	FDD
	42 <sup>33</sup>			-85.7	-85.4	-85.1	-84.9	TDD
CA_2A-46A <sup>15,16</sup>	2			-70	-67	-65.2	-64	FDD

CA_2A-2A-46A <sup>15,16</sup>	2			-70	-67	-65.2	-64	FDD
CA_2A-48A <sup>9,10</sup>	48			-71.7	-71.7	-71.7	-71.7	TDD
CA_2A-48A <sup>11</sup>	48			-97.1	-94.7	-93.2	-92.5	TDD

CA_2A-71A <sup>36</sup>	2			-93.4	-94	-92.5	-91.4	FDD
CA_2A-71A <sup>37</sup>	2			-96.8	-94	-92.5	-91.4	FDD
CA_2A-71A <sup>15,16</sup>	71			-70.4	-70.4	-70.4	-70.4	FDD
CA_2A-2A-71A <sup>36</sup>	2			-93.4	-94	-92.5	-91.4	FDD
CA_2A-2A-71A <sup>37</sup>	2			-96.8	-94	-92.5	-91.4	FDD
CA_2A-2A-71A <sup>15,16</sup>	71			-70.4	-70.4	-70.4	-70.4	FDD
CA_2A-4A-12A <sup>5,6</sup>	4 <sup>33</sup>			-90	-89.5	-89	-88.5	FDD
CA_2A-4A-28A <sup>5,6</sup>	4 <sup>33</sup>			-90	-89.5	-89	-88.5	FDD
CA_2A-4A-71A <sup>36</sup> , CA_2A-2A-4A-71A <sup>36</sup>	2			-93.1	-93.7	-92.2	-91.1	FDD
CA_2A-4A-71A <sup>37</sup> , CA_2A-2A-4A-71A <sup>37</sup>	2			-96.5	-93.7	-92.2	-91.1	FDD
CA_2A-4A-71A <sup>15,16</sup>	71			-70.4	-70.4	-70.4	-70.4	FDD
CA_2A-2A-4A-71A <sup>15,16</sup>	71			-70.4	-70.4	-70.4	-70.4	FDD
CA_2A-4A-5A-12A <sup>5,6</sup>	4 <sup>33</sup>			-90	-89.5	-89	-88.5	FDD
CA_2A-4A-7A-12A <sup>5,6</sup>	4 <sup>33</sup>			-90	-89.5	-89	-88.5	FDD
CA_2A-4A-12A-30A <sup>5,6</sup>	4 <sup>33</sup>			-90	-89.5	-89	-88.5	FDD
CA_2A-5A-12A-66A <sup>5,6</sup>	66			-89.5	-89	-88.5	-88	FDD
CA_2A-7A-12A-66A <sup>5,6</sup>	66 <sup>33</sup>			-89.5	-89	-88.5	-88	FDD
CA_2A-12A-66A <sup>5,6</sup>	66 <sup>33</sup>			-89.5	-89	-88.5	-88	FDD
CA_2A-13A-48A <sup>9,10</sup>	48			-71.7	-71.7	-71.7	-71.7	TDD
CA_2A-13A-48A <sup>11</sup>	48			-97.1	-94.7	-93.2	-92.5	TDD
CA_2A-13A-48A- 66A <sup>9,10</sup>	48			-71.7	-71.7	-71.7	-71.7	TDD
CA_2A-13A-48A-66A <sup>11</sup>	48			-97.1	-94.7	-93.2	-92.5	TDD
CA_2A-28A-66A <sup>5,6</sup>	66			-89.5	-88.9	-88.5	-88.2	FDD
CA_2A-48A-48A <sup>10,31</sup>	48			-71.7	-71.7	-71.7	-71.7	TDD
CA_2A-48A-48A <sup>11</sup>	48			-97.1	-94.7	-93.2	-92.5	TDD
CA_2A-48A-48C <sup>10,31</sup>	48			-71.7	-71.7	-71.7	-71.7	TDD
CA_2A-48A-48C <sup>11</sup>	48			-97.1	-94.7	-93.2	-92.5	TDD
CA_2A-48C <sup>9,10</sup>	48			-71.7	-71.7	-71.7	-71.7	TDD
CA_2A-48C <sup>11</sup>	48			-97.1	-94.7	-93.2	-92.5	TDD
CA_2A-48D <sup>9,10</sup>	48			-71.7	-71.7	-71.7	-71.7	TDD
CA_2A-48D <sup>11</sup>	48			-97.1	-94.7	-93.2	-92.5	TDD
CA_2A-48A-66A <sup>10,32</sup> , CA_2A-48C-66A <sup>10,32</sup>	48			-71.7	-71.7	-71.7	-71.7	TDD
CA_2A-48A-66A <sup>11</sup> , CA_2A-48C-66A <sup>11</sup>	48			-97.1	-94.7	-93.2	-92.5	TDD
CA_2A-66A-71A <sup>36</sup> , CA_2A-2A-66A-71A <sup>36</sup> , CA_2A-66A-66A-71A <sup>36</sup> , CA_2A-66C-71A <sup>36</sup>	2			-93.1	-93.7	-92.2	-91.1	FDD
CA_2A-66A-71A <sup>37</sup> , CA_2A-2A-66A-71A <sup>37</sup> , CA_2A-66A-66A-71A <sup>37</sup> , CA_2A-66C-71A <sup>37</sup>	2			-96.5	-93.7	-92.2	-91.1	FDD
CA_2A-66A-71A <sup>15,16</sup> , CA_2A-2A-66A- 71A <sup>15,16</sup> , CA_2A-66A-66A- 71A <sup>15,16</sup> , CA_2A-66C-71A <sup>15,16</sup>	71			-70.4	-70.4	-70.4	-70.4	FDD
CA_3A-5A-41A <sup>8,19,28</sup>	5 41			N/A	N/A	N/A	N/A	FDD TDD
CA_3A-7A-8A <sup>4</sup>	3			N/A	N/A	N/A	N/A	FDD
CA_3A-7A-8A <sup>5,6</sup>	7 <sup>33</sup>			-88	-87.4	-87	-86.7	FDD
CA_3C-7A-8A <sup>4</sup>	3			N/A	N/A	N/A	N/A	FDD
CA_3C-7A-8A <sup>5,6</sup>	7 <sup>33</sup>			-88	-87.4	-87	-86.7	FDD
CA_3A-7A-8A-20A <sup>4</sup>	3			N/A	N/A	N/A	N/A	FDD
CA_3A-7A-8A-20A <sup>5,6</sup>	7 <sup>33</sup>			-88	-87.4	-87	-86.7	FDD
CA_1A-3A-8A-20A <sup>4</sup>	3			N/A	N/A	N/A	N/A	FDD

CA_3A-7A-8A-38A <sup>4</sup>	3			N/A	N/A	N/A	N/A	FDD
CA_3A-7A-8A-40A <sup>4</sup>	3			N/A	N/A	N/A	N/A	FDD
CA_3A-7A-8A-40A <sup>5,6</sup>	7 <sup>33</sup>				-87.1	-86.7	-86.4	FDD
CA_3A-7A-20A-42A <sup>9,10</sup>	42 <sup>33</sup>			-71.7	-71.7	-71.7	-71.7	TDD
CA_3A-7A-20A-42A <sup>11</sup>	42 <sup>33</sup>			-97.1	-94.7	-93.2	-92.5	TDD
CA_3A-7A-28A-40A <sup>15,16</sup>	28			-60.7	-60.7	-60.7	-60.7	FDD
CA_3A-7A-42A <sup>9,10</sup>	42 <sup>33</sup>			-71.7	-71.7	-71.7	-71.7	TDD
CA_3A-7A-42A <sup>11</sup>	42 <sup>33</sup>			-97.1	-94.7	-93.2	-92.5	TDD
CA_3A-8A <sup>4</sup>	3			N/A	N/A	N/A	N/A	FDD
CA_3A-8A-11A <sup>4</sup>	3			N/A	N/A	N/A	N/A	FDD
CA_3A-8A-11A-28A <sup>4</sup>	3			N/A	N/A	N/A	N/A	FDD
CA_3A-8A-32A <sup>4</sup>	3			N/A	N/A	N/A	N/A	FDD
CA_3A-8A-38A <sup>4</sup>	3			N/A	N/A	N/A	N/A	FDD
CA_3C-8A-38A <sup>4</sup>	3			N/A	N/A	N/A	N/A	FDD
CA_3A-8A-40A <sup>4</sup>	3			N/A	N/A	N/A	N/A	FDD
CA_3A-8A-40C <sup>4</sup>	3			N/A	N/A	N/A	N/A	FDD
CA_3A-8A-42A <sup>4</sup>	3			N/A	N/A	N/A	N/A	FDD
CA_3A-8A-42C <sup>4</sup>	3			N/A	N/A	N/A	N/A	FDD
CA_3A-8A-42A <sup>9,10</sup>	42 <sup>33</sup>			-71.7	-71.7	-71.7	-71.7	TDD
CA_3A-8A-42C <sup>9,10</sup>	42 <sup>33</sup>			-71.7	-71.7	-71.7	-71.7	TDD
CA_3A-8A-42A <sup>11</sup>	42 <sup>33</sup>			-97.1	-94.7	-93.2	-92.5	TDD
CA_3A-8A-42C <sup>11</sup>	42 <sup>33</sup>			-97.1	-94.7	-93.2	-92.5	TDD
CA_3A-8A-42A <sup>12,13</sup>	42 <sup>33</sup>			-84.8	-84.7	-84.6	-84.5	TDD
CA_3A-8A-42C <sup>12,13</sup>	42 <sup>33</sup>			-84.8	-84.7	-84.6	-84.5	TDD
CA_3A-11A-28A <sup>9,10</sup>	11			-75.2	-75.2			FDD
CA_3A-18A-42A <sup>9,10</sup>	42 <sup>33</sup>			-71.7	-71.7	-71.7	-71.7	TDD
CA_3A-18A-42C <sup>9,10</sup>	42 <sup>33</sup>			-71.7	-71.7	-71.7	-71.7	TDD
CA_3A-18A-42A <sup>11</sup>	42 <sup>33</sup>			-97.1	-94.7	-93.2	-92.5	TDD
CA_3A-18A-42C <sup>11</sup>	42 <sup>33</sup>			-97.1	-94.7	-93.2	-92.5	TDD
CA_3A-19A-21A-42A <sup>25,26</sup>	42 <sup>33</sup>			-71.7	-71.7	-71.7	-71.7	TDD
CA_3A-19A-21A-42A <sup>27</sup>	42 <sup>33</sup>			-97.1	-94.7	-93.2	-92.5	TDD
CA_3A-19A-21A-42C <sup>25,26</sup>	42 <sup>33</sup>			-71.7	-71.7	-71.7	-71.7	TDD
CA_3A-19A-21A-42C <sup>27</sup>	42 <sup>33</sup>			-97.1	-94.7	-93.2	-92.5	TDD
CA_3A-19A-42A <sup>9,10</sup>	42 <sup>33</sup>			-71.7	-71.7	-71.7	-71.7	TDD
CA_3A-19A-42A <sup>11</sup>	42 <sup>33</sup>			-97.1	-94.7	-93.2	-92.5	TDD
CA_3A-20A-32A-42A <sup>9,10</sup>	42 <sup>33</sup>			-71.7	-71.7	-71.7	-71.7	TDD
CA_3A-20A-32A-42A <sup>11</sup>	42 <sup>33</sup>			-97.1	-94.7	-93.2	-92.5	TDD
CA_3A-20A-32A-42A <sup>12,13</sup>	42 <sup>33</sup>			-84.8	-84.7	-84.6	-84.5	TDD
CA_3A-20A-42A <sup>9,10</sup>	42 <sup>33</sup>			-71.7	-71.7	-71.7	-71.7	TDD
CA_3A-20A-42A <sup>11</sup>	42 <sup>33</sup>			-97.1	-94.7	-93.2	-92.5	TDD
CA_3A-21A-28A <sup>4,21</sup>	21			N/A	N/A	N/A		FDD
CA_3A-21A-28A-42A <sup>9,10</sup>	42 <sup>33</sup>			-71.7	-71.7	-71.7	-71.7	TDD
CA_3A-21A-28A-42A <sup>11</sup>	42 <sup>33</sup>			-97.1	-94.7	-93.2	-92.5	TDD
CA_3A-21A-28A-42C <sup>9,10</sup>	42 <sup>33</sup>			-71.7	-71.7	-71.7	-71.7	TDD
CA_3A-21A-28A-42C <sup>11</sup>	42 <sup>33</sup>			-97.1	-94.7	-93.2	-92.5	TDD
CA_3A-21A-42A <sup>9,10</sup>	42 <sup>33</sup>			-71.7	-71.7	-71.7	-71.7	TDD
CA_3A-21A-42A <sup>11</sup>	42 <sup>33</sup>			-97.1	-94.7	-93.2	-92.5	TDD
CA_3A-28A-40A <sup>15,16</sup>	28			-60.7	-60.7	-60.7	-60.7	FDD
CA_3A-28A-41A-42A <sup>9,10,29</sup>	41				-94.5	-92.7	-91.5	TDD
	42 <sup>33</sup>				-71.7	-71.7	-71.7	TDD
CA_3A-28A-41A-42A <sup>11,29</sup>	41				-94.5	-92.7	-91.5	TDD
	42 <sup>33</sup>				-94.7	-93.2	-92.5	TDD
CA_3A-28A-41A-42A <sup>17,18,29</sup>	41				-94.5	-92.7	-91.5	TDD
	42 <sup>33</sup>				-85.4	-85.1	-84.9	TDD

CA_3A-28A-42A <sup>9,10</sup>	42 <sup>33</sup>			-71.7	-71.7	-71.7	-71.7	TDD
CA_3A-28A-42A <sup>11</sup>	42 <sup>33</sup>			-97.1	-94.7	-93.2	-92.5	TDD
CA_3A-28A-42A <sup>17,18</sup>	42 <sup>33</sup>			-85.7	-85.4	-85.1	-84.9	TDD
CA_3A-31A <sup>12,13</sup>	3 <sup>33</sup>			-86.9	-86.4	-86	-85.6	FDD
CA_3A-32A-42A <sup>9,10</sup>	42 <sup>33</sup>			-71.7	-71.7	-71.7	-71.7	TDD
CA_3A-32A-42A <sup>11</sup>	42 <sup>33</sup>			-97.1	-94.7	-93.2	-92.5	TDD
CA_3A-42A <sup>9,10</sup>	42 <sup>33</sup>			-71.7	-71.7	-71.7	-71.7	TDD
CA_3A-42A <sup>11</sup>	42 <sup>33</sup>			-97.1	-94.7	-93.2	-92.5	TDD
CA_3A-42A-42A <sup>9,10</sup>	42 <sup>33</sup>			-71.7	-71.7	-71.7	-71.7	TDD
CA_3A-42A-42A <sup>11</sup>	42 <sup>33</sup>			-97.1	-94.7	-93.2	-92.5	TDD
CA_3A-3A-42A <sup>11</sup>	42 <sup>33</sup>			-97.1	-94.7	-93.2	-92.5	TDD
CA_3A-42A-43A <sup>9,10</sup>	42			-71.7	-71.7	-71.7	-71.7	TDD
CA_3A-42A-43A <sup>11</sup>	42			-97.1	-94.7	-93.2	-92.5	TDD
CA_3A-32A-42A-43A <sup>9,10</sup>	42			-71.7	-71.7	-71.7	-71.7	TDD
CA_3A-32A-42A-43A <sup>11</sup>	42			-97.1	-94.7	-93.2	-92.5	TDD
CA_4A-5A-12A <sup>5,6</sup>	4 <sup>33</sup>			-90	-89.5	-89	-88.5	FDD
CA_4A-7A-12A <sup>5,6</sup>	4 <sup>33</sup>			-90	-89.5	-89	-88.5	FDD
CA_4A-7A-28A <sup>5,6</sup>	4 <sup>33</sup>			-89.8	-89.4	-89	-88.7	FDD
CA_4A-12A <sup>5,6</sup>	4 <sup>33</sup>	-89.2	-89.2	-90	-89.5	-89	-88.5	FDD
CA_4A-12A-30A <sup>5,6</sup>	4 <sup>33</sup>			-90	-89.5	-89	-88.5	FDD
CA_4A-17A <sup>5,6</sup>	4 <sup>33</sup>			-90	-89.5			FDD
CA_4A-28A <sup>5,6</sup>	4 <sup>33</sup>			-89.8	-89.4	-89	-88.7	FDD
CA_5A-12A-66A <sup>5,6</sup>	66 <sup>33</sup>			-90	-89.5	-89	-88.5	FDD
CA_5A-38A <sup>8,19</sup>	5			N/A	N/A			FDD
CA_5A-41A <sup>8,19</sup>	38,41			N/A	N/A	N/A	N/A	TDD
CA_5A-40A-41A <sup>8,19</sup>				N/A	N/A	N/A	N/A	TDD
CA_5A-48A-66A <sup>9,10</sup>	48 <sup>33</sup>			-71.7	-71.7	-71.7	-71.7	TDD
CA_5A-48A-66A-66A <sup>9,10</sup>								
CA_5A-48A-66A <sup>11</sup>	48 <sup>33</sup>			-97.1	-94.7	-93.2	-92.5	TDD
CA_5A-48A-66A-66A <sup>11</sup>								
CA_7A-8A <sup>5,6</sup>	7 <sup>33</sup>			-88	-87.4	-87	-86.7	FDD
CA_7A-8A-20A <sup>5,6</sup>	7 <sup>33</sup>				-87.4	-87	-86.7	FDD
CA_7A-12A-66A <sup>5,6</sup>	66 <sup>33</sup>			-89.5	-89	-88.5	-88	FDD
CA_7A-12B-66A <sup>5,6</sup>	66 <sup>33</sup>			-89.5	-89	-88.5	-88	FDD
CA_7A-20A-38A <sup>8</sup>	38			N/A	N/A	N/A	N/A	TDD
CA_7A-28A-40A <sup>15,16</sup>								
CA_7A-28A-40C <sup>15,16</sup>	28			-60.7	-60.7	-60.7	-60.7	FDD
CA_8A-28A-41A <sup>28</sup>	41			N/A	N/A	N/A	N/A	TDD
CA_8A-39A-41A <sup>8</sup>	41			N/A	N/A	N/A	N/A	TDD
CA_8A-41A <sup>8</sup>	41			N/A	N/A	N/A	N/A	TDD
CA_8A-42A <sup>12,13</sup>	42 <sup>33</sup>			-84.8	-84.7	-84.6	-84.5	TDD
CA_8A_11A_42A <sup>12,13</sup>	42 <sup>33</sup>			-84.8	-84.7	-84.6	-84.5	TDD
CA_8A_11A_42C <sup>12,13</sup>								
CA_11A-28A <sup>9,10</sup>	11 <sup>33</sup>			-75.2	-75.2			FDD
CA_12A-30A-66A <sup>5,6</sup>	66 <sup>33</sup>			-89.5	-89	-88.5	-88	FDD
CA_12A-66A <sup>5,6</sup>	66 <sup>33</sup>	-88.7	-88.7	-89.5	-89	-88.5	-88	FDD
CA_13A-48A-66A <sup>9,10</sup>								
CA_13A-48A-66A-66A <sup>9,10</sup>								
CA_13A-48A-66B <sup>9,10</sup>								
CA_13A-48A-66C <sup>9,10</sup>								
CA_13A-48A-48A-66A <sup>9,10</sup>	48 <sup>33</sup>			-71.7	-71.7	-71.7	-71.7	TDD
CA_13A-48C-66A <sup>9,10</sup>								
CA_13A-48D-66A <sup>9,10</sup>								
CA_13A-48A-48C-66A <sup>9,10</sup>								

CA_13A-48A-66A <sup>11</sup> CA_13A-48A-66A-66A <sup>11</sup> CA_13A-48A-66B <sup>11</sup> CA_13A-48A-66C <sup>11</sup> CA_13A-48A-48A-66A <sup>11</sup> CA_13A-48C-66A <sup>11</sup> CA_13A-48D-66A <sup>11</sup> CA_13A-48A-48C-66A <sup>11</sup> CA_13A-48E-66A	48 <sup>33</sup>			-97.1	-94.7	-93.2	-92.5	TDD
CA_18A-41A <sup>19</sup> CA_18A-41C <sup>19</sup>	41			N/A	N/A	N/A	N/A	TDD
CA_20A-32A-42A <sup>12,13</sup>	20			-97				FDD
	32			-100	-97	-95.2	-94	FDD
	42 <sup>33</sup>			-84.8	-84.7	-84.6	-84.5	TDD
CA_20A-38A <sup>8</sup> CA_20A-38C <sup>8</sup>	20			N/A	N/A	N/A	N/A	FDD
CA_20A-38A-40D <sup>15,16</sup>	20			-60.7	-60.7	-60.7		FDD
CA_20A-40A <sup>15,16</sup>	20 <sup>33</sup>			-60.7	-60.7	-60.7	-60.7	FDD
CA_20A-40A-40A <sup>15,16</sup>	20 <sup>33</sup>			-60.7	-60.7	-60.7		FDD
CA_20A-38A-40A <sup>15,16</sup>	20 <sup>33</sup>			-60.7	-60.7	-60.7		FDD
CA_20A-40C <sup>15,16</sup>	20 <sup>33</sup>			-60.7	-60.7	-60.7		FDD
CA_20A-40D <sup>15,16</sup>	20			-60.7	-60.7	-60.7		FDD
CA_20A-38A-40A-40A <sup>15,16</sup>	20			-60.7	-60.7	-60.7		FDD
CA_20A-38A-40C <sup>15,16</sup>	20			-60.7	-60.7	-60.7		FDD
CA_20A-42A <sup>12,13</sup> CA_20A-42A-42A <sup>12,13</sup>	42 <sup>33</sup>			-84.8	-84.7	-84.6	-84.5	TDD
CA_20A-41A <sup>5,6</sup> CA_20A-41C <sup>5,6</sup> CA_20A-41D <sup>5,6</sup>	41			-85.1	-84.7	-84.8	-84.6	TDD
CA_21A-28A <sup>4,21</sup>	21			N/A	N/A	N/A		FDD
CA_21A-28A-42A <sup>4,21</sup>	21			N/A	N/A	N/A	N/A	FDD
CA_25A-26A-41A <sup>38</sup>	41			N/A	N/A	N/A	N/A	TDD
CA_26A-41A <sup>8,19</sup> CA_25A-25A-26A-41A <sup>8,19</sup> CA_25A-26A-41C <sup>8,19</sup>	26 41			N/A N/A	N/A N/A	N/A N/A	N/A N/A	FDD TDD
CA_28A-32A <sup>9,10</sup>	32			-72.2	-72.2	-72.2	-72.2	FDD
CA_28A-32A <sup>11</sup>	32			-97.6	-95.2	-93.7	-93.0	FDD
CA_28A-40A <sup>15,16</sup>	28			-60.7	-60.7	-60.7	-60.7	FDD
CA_28A-41A-42A <sup>17,18</sup>	42 <sup>33</sup>				-85.4	-85.1	-84.9	TDD
CA_28A-42A <sup>17,18</sup>	42 <sup>33</sup>			-85.7	-85.4	-85.1	-84.9	TDD
CA_28A-66A <sup>5,6</sup>	66			-89.5	-88.9	-88.5	-88.2	FDD
CA_48A-66A <sup>9,10</sup>	48			-71.7	-71.7	-71.7	-71.7	TDD
CA_48A-66A <sup>11</sup>	48			-97.1	-94.7	-93.2	-92.5	TDD

CA_48A-66B <sup>9,10</sup>	48			-71.7	-71.7	-71.7	-71.7	TDD
CA_48A-66B <sup>11</sup>	48			-97.1	-94.7	-93.2	-92.5	TDD
CA_48A-66C <sup>9,10</sup>	48			-71.7	-71.7	-71.7	-71.7	TDD
CA_48A-66C <sup>11</sup>	48			-97.1	-94.7	-93.2	-92.5	TDD
CA_48A-48A-66A <sup>9,10</sup>	48			-71.7	-71.7	-71.7	-71.7	TDD
CA_48A-48A-66A <sup>11</sup>	48			-97.1	-94.7	-93.2	-92.5	TDD
CA_48A-66A-66A <sup>9,10</sup>	48			-71.7	-71.7	-71.7	-71.7	TDD
CA_48A-66A-66A <sup>11</sup>	48			-97.1	-94.7	-93.2	-92.5	TDD
CA_48A-48A-66A-66A <sup>9,10</sup>	48			-71.7	-71.7	-71.7	-71.7	TDD
CA_48A-48A-66A-66A <sup>11</sup>	48			-97.1	-94.7	-93.2	-92.5	TDD
CA_48A-48A-66B <sup>9,10</sup>	48			-71.7	-71.7	-71.7	-71.7	TDD
CA_48A-48A-66B <sup>11</sup>	48			-97.1	-94.7	-93.2	-92.5	TDD
CA_48A-48A-66C <sup>9,10</sup>	48			-71.7	-71.7	-71.7	-71.7	TDD
CA_48A-48A-66C <sup>11</sup>	48			-97.1	-94.7	-93.2	-92.5	TDD
CA_48C-66A-66A <sup>9,10</sup>	48			-71.7	-71.7	-71.7	-71.7	TDD
	66			-99.3	-96.3	-94.5	-93.2	FDD
CA_48C-66A-66A <sup>11</sup>	48			-97.1	-94.7	-93.2	-92.5	TDD
	66			-99.3	-96.3	-94.5	-93.2	FDD
CA_48C-66B <sup>9,10</sup>	48			-71.7	-71.7	-71.7	-71.7	TDD
CA_48C-66B <sup>11</sup>	48			-97.1	-94.7	-93.2	-92.5	TDD
CA_48C-66C <sup>9,10</sup>	48			-71.7	-71.7	-71.7	-71.7	TDD
CA_48C-66C <sup>11</sup>	48			-97.1	-94.7	-93.2	-92.5	TDD
CA_48C-66A <sup>9,10</sup>	48			-71.7	-71.7	-71.7	-71.7	TDD
CA_48C-66A <sup>11</sup>	48			-97.1	-94.7	-93.2	-92.5	TDD
CA_48E-66A <sup>9,10</sup>	48			-71.7	-71.7	-71.7	-71.7	TDD
CA_48E-66A <sup>11</sup>	48			-97.1	-94.7	-93.2	-92.5	TDD
CA_66A-70A-71A <sup>5,6</sup>	70			-90	-89.5	-89.2		FDD
CA_66A-66A-70A-71A <sup>5,6</sup>	70			-90	-89.5	-89.2		FDD
CA_66A-70C-71A <sup>5,6,35</sup>	70			-90	-89.5	-89.2	-89	FDD
CA_66A-66A-70C-71A <sup>5,6,35</sup>	70			-90	-89.5	-89.2	-89	FDD
CA_66C-70A-71A <sup>5,6</sup>	70			-90	-89.5	-89.2		FDD
CA_66C-70C-71A <sup>5,6,35</sup>	70			-90	-89.5	-89.2	-89	FDD
CA_70A-71A <sup>5,6</sup>	70			-90	-89.5	-89.2		FDD
CA_70C-71A <sup>5,6,35</sup>	70			-90	-89.5	-89.2	-89	FDD



- NOTE 1: The transmitter shall be set to  $P_{\text{UMAX}}$  as defined in subclause 6.2.5A.
- NOTE 2: Reference measurement channel is A.3.2 with one sided dynamic OCNG Pattern OP.1 FDD/TDD/FS3 as described in Annex A.5.1.1/A.5.2.1/A.5.4.1.
- NOTE 3: The signal power is specified per port
- NOTE 4: No requirements apply when there is at least one individual RE within the uplink transmission bandwidth of the low band for which the 2<sup>nd</sup> transmitter harmonic is within the downlink transmission bandwidth of the high band. The reference sensitivity for all active downlink component carriers is only verified when this is not the case (the requirements specified in clause 7.3.1 apply unless otherwise specified).
- NOTE 5: These requirements apply when there is at least one individual RE within the uplink transmission bandwidth of a low band for which the 3<sup>rd</sup> transmitter harmonic is within the downlink transmission bandwidth of a high band.
- NOTE 6: The requirements should be verified for UL EARFCN of a low band (superscript LB) such that  $f_{\text{UL}}^{\text{LB}} = \lfloor f_{\text{DL}}^{\text{HB}} / 0.3 \rfloor 0.1$  in MHz and  $F_{\text{UL}_{\text{low}}}^{\text{LB}} + BW_{\text{Channel}}^{\text{LB}} / 2 \leq f_{\text{UL}}^{\text{LB}} \leq F_{\text{UL}_{\text{high}}}^{\text{LB}} - BW_{\text{Channel}}^{\text{LB}} / 2$  with  $f_{\text{DL}}^{\text{HB}}$  the carrier frequency of a high band in MHz and  $BW_{\text{Channel}}^{\text{LB}}$  the channel bandwidth configured in the low band.
- NOTE 7: Void.
- NOTE 8: No requirements apply when there is at least one individual RE within the uplink transmission bandwidth of the low band for which the 3<sup>rd</sup> transmitter harmonic is within the downlink transmission bandwidth of the high band. The reference sensitivity is only verified when this is not the case (the requirements specified in clause 7.3.1 apply).
- NOTE 9: These requirements apply when there is at least one individual RE within the uplink transmission bandwidth of the aggressor (lower) band for which the 2<sup>nd</sup> transmitter harmonic is within the downlink transmission bandwidth of a victim (higher) band and a range  $\Delta F_{\text{HD}}$  above and below the edge of this downlink transmission bandwidth. The value  $\Delta F_{\text{HD}}$  depends on the E-UTRA configuration:  $\Delta F_{\text{HD}} = 10$  MHz for CA\_3A-42A, CA\_3A-3A-42A, CA\_3A-42A-42A, CA\_1A-3A-20A-32A-42A, CA\_3A-42A-43A, CA\_3A-32A-42A-43A, CA\_1A-3A-42A, CA\_2A-13A-48A-66A, CA\_2A-48A, CA\_2A-48C, CA\_2A-48D, CA\_48A-66A, CA\_3A-7A-42A, CA\_3A-19A-42A, CA\_3A-20A-42A, CA\_3A-28A-42A, CA\_1A-3A-7A-42A, CA\_5A-48A-66A, CA\_5A-48A-66A-66A, CA\_13A-48A-66A, CA\_13A-48A-66A-66A, CA\_13A-48A-66B, CA\_13A-48A-66C, CA\_13A-48A-48A-66A, CA\_13A-48C-66A, CA\_13A-48D-66A, CA\_13A-48A-48C-66A, CA\_28A-32A, CA\_48A-66A-66A, CA\_48A-66B, CA\_48A-66C, CA\_48A-48A-66A, CA\_48C-66A, CA\_48A-48A-66A-66A, CA\_48A-48A-66B, CA\_48A-48A-66C, CA\_48C-66B, CA\_48C-66C, CA\_48E-66A, CA\_1A-3A-18A-42A, CA\_1A-3A-19A-42A, CA\_1A-3A-32A-42A, CA\_1A-3A-41A-42A, CA\_3A-7A-20A-42A, CA\_3A-20A-32A-42A, CA\_3A-28A-41A-42A, CA\_3A-18A-42A, CA\_3A-18A-42C, CA\_3A-8A-42A and CA\_3A-8A-42C.  $\Delta F_{\text{HD}} = 0$  MHz for CA\_11A-28A, CA\_1A-11A-28A and CA\_3A-11A-28A.
- NOTE 10: The requirements should be verified for UL EARFCN of the aggressor (lower) band (superscript LB) such that  $f_{\text{UL}}^{\text{LB}} = \lfloor f_{\text{DL}}^{\text{HB}} / 0.2 \rfloor 0.1$  in MHz and  $F_{\text{UL}_{\text{low}}}^{\text{LB}} + BW_{\text{Channel}}^{\text{LB}} / 2 \leq f_{\text{UL}}^{\text{LB}} \leq F_{\text{UL}_{\text{high}}}^{\text{LB}} - BW_{\text{Channel}}^{\text{LB}} / 2$  with  $f_{\text{DL}}^{\text{HB}}$  carrier frequency in the victim (higher) band in MHz and  $BW_{\text{Channel}}^{\text{LB}}$  the channel bandwidth configured in the lower band.
- NOTE 11: The requirements are only applicable to channel bandwidths with a carrier frequency at  $\pm(20 + BW_{\text{Channel}}^{\text{HB}} / 2)$  MHz offset from  $2f_{\text{UL}}^{\text{LB}}$  in the victim (higher) band with  $F_{\text{UL}_{\text{low}}}^{\text{LB}} + BW_{\text{Channel}}^{\text{LB}} / 2 \leq f_{\text{UL}}^{\text{LB}} \leq F_{\text{UL}_{\text{high}}}^{\text{LB}} - BW_{\text{Channel}}^{\text{LB}} / 2$ , where  $BW_{\text{Channel}}^{\text{LB}}$  and  $BW_{\text{Channel}}^{\text{HB}}$  are the channel bandwidths configured in the aggressor (lower) and victim (higher) bands in MHz, respectively.
- NOTE 12: These requirements apply when there is at least one individual RE within the uplink transmission bandwidth of a low band for which the 4<sup>th</sup> transmitter harmonic is within the downlink transmission bandwidth of a high band.
- NOTE 13: The requirements should be verified for UL EARFCN of a low band (superscript LB) such that  $f_{\text{UL}}^{\text{LB}} = \lfloor f_{\text{DL}}^{\text{HB}} / 0.4 \rfloor 0.1$  in MHz and  $F_{\text{UL}_{\text{low}}}^{\text{LB}} + BW_{\text{Channel}}^{\text{LB}} / 2 \leq f_{\text{UL}}^{\text{LB}} \leq F_{\text{UL}_{\text{high}}}^{\text{LB}} - BW_{\text{Channel}}^{\text{LB}} / 2$  with  $f_{\text{DL}}^{\text{HB}}$  the carrier frequency of a high band in MHz and  $BW_{\text{Channel}}^{\text{LB}}$  the channel bandwidth configured in the low band.
- NOTE 14: For the UE that supports CA\_1A-18A-28A or CA\_1A-19A-28A, no requirements apply when there is at least one individual RE within the uplink transmission bandwidth of the low band for which the 3<sup>rd</sup> transmitter harmonic is within the downlink transmission bandwidth of the high band. The reference sensitivity should only be verified when this is not the case (the requirements specified in clause 7.3.1 apply).
- NOTE 15: These requirements apply when there is at least one individual RE within the downlink transmission bandwidth of the victim (lower) band for which the 3<sup>rd</sup> harmonic is within the uplink transmission bandwidth or the uplink adjacent channel's transmission bandwidth of an aggressor (higher) band.
- NOTE 16: The requirements should be verified for UL EARFCN of the aggressor (higher) band (superscript HB) such that  $f_{\text{DL}}^{\text{LB}} = \lfloor f_{\text{UL}}^{\text{HB}} / 0.3 \rfloor 0.1$  in MHz and  $F_{\text{UL}_{\text{low}}}^{\text{LB}} + BW_{\text{Channel}}^{\text{LB}} / 2 \leq f_{\text{UL}}^{\text{LB}} \leq F_{\text{UL}_{\text{high}}}^{\text{LB}} - BW_{\text{Channel}}^{\text{LB}} / 2$  with  $f_{\text{DL}}^{\text{LB}}$  the carrier frequency in the victim (lower) band and  $BW_{\text{Channel}}^{\text{HB}}$  the channel bandwidth configured in the higher band.
- NOTE 17: These requirements apply when there is at least one individual RE within the uplink transmission bandwidth of a low band for which the 5<sup>th</sup> transmitter harmonic is within the downlink transmission bandwidth of a high band.

- NOTE 18: The requirements should be verified for UL EARFCN of a low band (superscript LB) such that  $f_{UL}^{LB} = \lfloor f_{DL}^{HB} / 0.5 \rfloor .1$  in MHz and  $F_{UL\_low}^{LB} + BW_{Channel}^{LB} / 2 \leq f_{UL}^{LB} \leq F_{UL\_high}^{LB} - BW_{Channel}^{LB} / 2$  with  $f_{DL}^{HB}$  the carrier frequency of a high band in MHz and  $BW_{Channel}^{LB}$  the channel bandwidth configured in the low band.
- NOTE 19: No requirements apply for the case that there is at least one individual RE within the uplink transmission bandwidth of the relative higher band and when the frequency range of relative higher band's uplink channel bandwidth or uplink 1<sup>st</sup> adjacent channel bandwidth is fully or partially overlapped with the 3 times of the frequency range of the relative lower band's downlink channel bandwidth. The reference sensitivity is only verified when this is not the case (the requirements specified in clause 7.3.1 apply).
- NOTE 20: Void
- NOTE 21: No requirements apply when there is at least one individual RE on band 28 uplink outside frequencies 728 – 738 MHz. The reference sensitivity is only verified when all configured RE's are confined within frequencies 728 – 738 MHz (the requirements specified in clause 7.3.1 of [6] apply).
- NOTE 22: These requirements apply when there is at least one individual RE within the uplink transmission bandwidth of the aggressor (lower) band for which the 2<sup>nd</sup> transmitter harmonic is within the downlink transmission bandwidth of a victim (higher) band and a range  $\Delta F_{HD}$  above and below the edge of this downlink transmission bandwidth. The value  $\Delta F_{HD}$  depends on the E-UTRA configuration:  $\Delta F_{HD} = 10$  MHz for CA\_1A-3A-21A-42A.
- NOTE 23: The requirements should be verified for UL EARFCN of the aggressor (lower) band (superscript LB) such that  $f_{UL}^{LB} = \lfloor f_{DL}^{HB} / 0.2 \rfloor .1$  in MHz and  $F_{UL\_low}^{LB} + BW_{Channel}^{LB} / 2 < f_{UL}^{LB} < F_{UL\_high}^{LB} - BW_{Channel}^{LB} / 2$  with  $f_{DL}^{HB}$  carrier frequency in the victim (higher) band in MHz and  $BW_{Channel}^{LB}$  the channel bandwidth configured in the lower band.
- NOTE 24: The requirements are only applicable to channel bandwidths with a carrier frequency at  $\pm(20 + BW_{Channel}^{HB} / 2)$  MHz offset from  $2f_{UL}^{LB}$  in the victim (higher band) with  $F_{UL\_low}^{LB} + BW_{Channel}^{LB} / 2 < f_{UL}^{LB} < F_{UL\_high}^{LB} - BW_{Channel}^{LB} / 2$ , where  $BW_{Channel}^{LB}$  and  $BW_{Channel}^{HB}$  are the channel bandwidths configured in the aggressor (lower) and victim (higher) bands in MHz, respectively.
- NOTE 25: These requirements apply when there is at least one individual RE within the uplink transmission bandwidth of the aggressor (lower) band for which the 2<sup>nd</sup> transmitter harmonic is within the downlink transmission bandwidth of a victim (higher) band and a range  $\Delta F_{HD}$  above and below the edge of this downlink transmission bandwidth. The value  $\Delta F_{HD}$  depends on the E-UTRA configuration:  $\Delta F_{HD} = 10$  MHz for CA\_3A-19A-21A-42A.
- NOTE 26: The requirements should be verified for UL EARFCN of the aggressor (lower) band (superscript LB) such that  $f_{UL}^{LB} = \lfloor f_{DL}^{HB} / 0.2 \rfloor .1$  in MHz and  $F_{UL\_low}^{LB} + BW_{Channel}^{LB} / 2 < f_{UL}^{LB} < F_{UL\_high}^{LB} - BW_{Channel}^{LB} / 2$  with  $f_{DL}^{HB}$  carrier frequency in the victim (higher) band in MHz and  $BW_{Channel}^{LB}$  the channel bandwidth configured in the lower band.
- NOTE 27: The requirements are only applicable to channel bandwidths with a carrier frequency at  $\pm(20 + BW_{Channel}^{HB} / 2)$  MHz offset from  $2f_{UL}^{LB}$  in the victim (higher band) with  $F_{UL\_low}^{LB} + BW_{Channel}^{LB} / 2 < f_{UL}^{LB} < F_{UL\_high}^{LB} - BW_{Channel}^{LB} / 2$ , where  $BW_{Channel}^{LB}$  and  $BW_{Channel}^{HB}$  are the channel bandwidths configured in the aggressor (lower) and victim (higher) bands in MHz, respectively.
- NOTE 28: No requirements apply when there is at least one individual RE within the uplink transmission bandwidth of either Band 5 or Band 8 for which the 3<sup>rd</sup> transmitter harmonic is within the downlink transmission bandwidth of Band 41. The reference sensitivity for all active downlink component carriers is only verified when this is not the case (the requirements specified in clause 7.3.1 apply).
- NOTE 29: The B41 requirements are modified by -0.1dB when carrier frequency of the assigned E-UTRA channel bandwidth is within 2545-2690 MHz.
- NOTE 30: Void
- NOTE 31: These requirements apply when there is at least one individual RE within the uplink transmission bandwidth of the aggressor (lower) band for which the 2<sup>nd</sup> transmitter harmonic is within the downlink transmission bandwidth of a victim (higher) band and a range  $\Delta F_{HD}$  above and below the edge of this downlink transmission bandwidth. The value  $\Delta F_{HD}$  depends on the E-UTRA configuration:  $\Delta F_{HD} = 10$  MHz for CA\_2A-48A-48A and CA\_2A-48A-48C
- NOTE 32: These requirements apply when there is at least one individual RE within the uplink transmission bandwidth of the aggressor (lower) band for which the 2<sup>nd</sup> transmitter harmonic is within the downlink transmission bandwidth of a victim (higher) band and a range  $\Delta F_{HD}$  above and below the edge of this downlink transmission bandwidth. The value  $\Delta F_{HD}$  depends on the E-UTRA configuration:  $\Delta F_{HD} = 10$  MHz for CA\_2A-48A-66A, CA\_2A-48A-66A-66A and CA\_2A-48C-66A
- NOTE 33: Applicable for the operations with 2 or 4 antenna ports supported in the band with carrier aggregation configured.
- NOTE 34: Void
- NOTE 35: These exceptions for the intra-band class C carriers should be verified one carrier at a time, according to note 6 frequency arrangements. No exceptions apply for the carrier which is not under REFSSENS exception test.

NOTE 36: These requirements apply when the lower edge frequency of the 5 MHz uplink channel in Band 71 is located at or below 668 MHz and the downlink channel in Band 2 is located with its upper edge at 1990 MHz.

NOTE 37: These requirements apply when the lower edge frequency of the 10 MHz, 15 MHz, or 20 MHz uplink channel in Band 71 is located at or below 668 MHz and the downlink channel in Band 2 is located with its upper edge at 1990 MHz.

Note 38: These requirements apply when there is at least one individual RE within the uplink transmission bandwidth of the aggressor (lower) band for which the 3rd transmitter harmonic is within the downlink transmission bandwidth of a victim (higher) band and a range  $\Delta F_{HD}$  above and below the edge of this downlink transmission bandwidth. The value  $\Delta F_{HD}$  depends on the E-UTRA configuration:  $\Delta F_{HD} = 15$  MHz for CA\_26A-41A, CA\_25A-26A-41A.

**Table 7.3.1A-0b: Uplink configuration for the low band (exceptions due to harmonic issue)**

E-UTRA Band / Channel bandwidth of the high band / N <sub>RB</sub> / Duplex mode								
EUTRA CA Configuration	UL band	1.4 MHz	3 MHz	5 MHz	10 MHz	15 MHz	20 MHz	Duplex mode
CA_1A-3A-5A-7A-28A	28			8	16	25	25	FDD
CA_1A-3A-5A-28A	28			8	16	25	25	FDD
CA_1A-3A-7A-8A	8			8	16	25	25	FDD
CA_1A-3C-7A-8A	8			8	16	25	25	FDD
CA_1A-3A-7A-8A-20A	8			8	16	25	25	FDD
CA_1A-3A-7A-20A-28A	28			8	16	25	25	FDD
CA_1A-3A-7A-20A-42A	3			12	25	36	50	FDD
CA_1A-3A-7A-28A	28				16	25	25	FDD
CA_1A-3A-7A-42A	3			12	25	36	50	FDD
CA_1A-3A-8A-42A	8			8	16	25	25	FDD
CA_1A-3A-8A-42A	3			12	25	36	50	FDD
CA_1A-3A-11A-28A <sup>4</sup>	28			8	16	25	25	FDD
CA_1A-3A-11A-28A <sup>5</sup>	28			12	25			FDD
CA_1A-3A-18A-42A	3			12	25	36	50	FDD
CA_1A-3A-19A-42A	3			12	25	36	50	FDD
CA_1A-3A-28A CA_1A-1A-3A-28A CA_1A-3A-3A-28A	28			8	16	25	25	FDD
CA_1A-3A-42A	3			12	25	36	50	FDD
CA_1A-3A-3A-42A	3			12	25	36	50	FDD
CA_1A-3A-42A-42A	3			12	25	36	50	FDD
CA_1A-3A-42A-42C	3			12	25	36	50	FDD
CA_1A-3A-42C-42C	3			12	25	36	50	FDD
CA_1A-3A-20A-28A	28			8	16	25	25	FDD
CA_1A-3A-21A-42A	3			12	25	36	50	FDD
CA_1A-3A-28A-40A	40			25	50	75	100	TDD
CA_1A-3A-28A-42A	3			12	25	36	50	FDD
CA_1A-3A-41A-42A	3			12	25	36	50	FDD
CA_1A-5A-7A-28A	28			8	16	25	25	FDD
CA_1A-7A-8A	8			8	16	25	25	FDD
CA_1A-3A-32A-42A	3			12	25	36	50	FDD
CA_1A-3A-42A-43A	3			12	25	36	50	FDD
CA_1A-7A-8A-20A CA_1A-7A-7A-8A	8			8	16			FDD
CA_1A-7A-8A-40A	8			8	16	25	25	FDD
CA_1A-7A-20A-28A	28			8	16	25	25	FDD
CA_1A-7A-28A	28			8	16	25	25	FDD
CA_1A-7A-28A-40A	40			25	50	75	100	TDD
CA_1A-8A-20A-28A	28			8	16	25	25	FDD
CA_1A-8A-42A CA_1A-8A-42C	8			8	16	25	25	FDD
CA_1A-8A-11A-42A	8			e	16	25	25	FDD
CA_1A-11A-28A <sup>4</sup>	28			8	16	25	25	FDD
CA_1A-11A-28A <sup>5</sup>	28			12	25			FDD
CA_1A-20A-28A	28			8	16	25	25	FDD
CA_1A-20A-32A-42A	20			8	16	25	25	FDD
CA_1A-3A-20A-32A-42A	3			12	25	36	50	FDD
	20			8	16	25	25	FDD
CA_1A-3A-32A-42A-43A	3			12	25	36	50	FDD
CA_1A-28A	28			8	16	25	25	FDD
CA_1A-1A-28A	28			8	16	25	25	FDD

CA_1A-28A-40A	40			25	50	75	100	TDD
CA_1A-28A-42A	28			8	16	25	25	FDD
CA_2A-46A	46						100	TDD
CA_2A-2A-46A	46						100	TDD
CA_2A-71A	71			25	25 <sup>1</sup>	20 <sup>1</sup>	20 <sup>1</sup>	FDD
CA_2A-71A	2			25	50	50	50	FDD
CA_2A-2A-71A	71			25	50	50	50	FDD
CA_2A-4A-12A	12			8	16	20	20	FDD
CA_2A-4A-28A	28			8	16	25		FDD
CA_2A-4A-71A CA_2A-2A-4A-71A	71			25	50	50	50	FDD
CA_2A-4A-5A-12A	12			8	16			FDD
CA_2A-4A-7A-12A	12			8	16			FDD
CA_2A-4A-12A-30A	12			8	16			FDD
CA_2A-5A-12A-66A	12			8	16	20	20	FDD
CA_2A-7A-12A-66A	12			8	16			FDD
CA_2A-12A-66A	12			8	16			FDD
CA_2A-13A-48A	2			25	50	50 <sup>1</sup>	50 <sup>1</sup>	FDD
CA_2A-13A-48A-66A	2			25	50	50 <sup>1</sup>	50 <sup>1</sup>	FDD
	66			12 <sup>1</sup>	25 <sup>1</sup>	36 <sup>1</sup>	50 <sup>1</sup>	
CA_2A-48A CA_2A-48A-48A CA_2A-48A-48C CA_2A-48D	2			25	50	50 <sup>1</sup>	50 <sup>1</sup>	FDD
CA_2A-48A-66A CA_2A-48C-66A CA_2A-48A-66A-66A	2			25	50	50 <sup>1</sup>	50 <sup>1</sup>	FDD
	66			12 <sup>1</sup>	25 <sup>1</sup>	36 <sup>1</sup>	50 <sup>1</sup>	FDD
CA_2A-66A-71A CA_2A-2A-66A-71A CA_2A-66A-66A-71A CA_2A-66C-71A	71			25	50	50	50	FDD
CA_3A-7A-8A	8			8	16	25	25	FDD
CA_3C-7A-8A	8			8	16	25	25	FDD
CA_3A-7A-20A-42A	3			12	25	36	50	FDD
CA_3A-7A-8A-40A	8			8	16	25	25	FDD
CA_3A-7A-28A-40A	40			25	50	75	100	TDD
CA_3A-7A-42A	3			12	25	36	50	FDD
CA_3A-8A-32A	8			8	16	25	25	FDD
CA_3A-8A-42A CA_3A-8A-42C	3			12	25	36	50	FDD
CA_3A-8A-42A CA_3A-8A-42C	8			8	16	25	25	FDD
CA_3A-11A-28A	28			12	25			FDD
CA_3A-18A-42A CA_3A-18A-42C	3			12	25	36	50	FDD
CA_3A-19A-42A	3			12	25	36	50	FDD
CA_3A-19A-21A-42A	3			12	25	36	50	FDD
CA_3A-20A-32A-42A	3			12	25	36	50	FDD
	20			8	16	25	25	
CA_3A-19A-21A-42C	3			12	25	36	50	FDD
CA_3A-20A-42A	3			12	25	36	50	FDD
CA_3A-21A-28A-42A	3			12	25	36	50	FDD
CA_3A-21A-28A-42C	3			12	25	36	50	FDD
CA_3A-21A-42A	3			12	25	36	50	FDD
CA_3A-28A-40A	40			25	50	75	100	TDD
CA_3A-28A-41A-42A	3				25	36	50	FDD
CA_3A-28A-41A-42A	28				10	15	20	FDD

CA_3A-31A	31			5	5	5	5	FDD
CA_3A-32A-42A	3			12	25	36	50	FDD
CA_3A-32A-42A-43A	3			12	25	36	50	FDD
CA_3A-42A	3			12	25	36	50	FDD
CA_3A-3A-42A	3			12	25	36	50	FDD
CA_3A-42A-42A	3			12	25	36	50	FDD
CA_3A-42A-43A	3			12	25	36	50	FDD
CA_4A-5A-12A	12			8	16	20	20	FDD
CA_4A-7A-12A	12			8	16	20	20	FDD
CA_4A-7A-28A	28			[8]	[16]	[25]	[25]	FDD
CA_4A-12A	12	2	5	8	16	20	20	FDD
CA_4A-12A-30A	12			8	16			FDD
CA_4A-17A	17			8	16			FDD
CA_4A-28A	28			[8]	[16]	[25]	[25]	FDD
CA_5A-12A-66A	12			8	16	20	20	FDD
CA_5A-48A-66A CA_5A-48A-66A-66A	66			12 <sup>1</sup>	25 <sup>1</sup>	36 <sup>1</sup>	50 <sup>1</sup>	FDD
CA_7A-8A	8			8	16	25	25	FDD
CA_7A-8A-20A	8				16	25	25	FDD
CA_7A-12A-66A	12			8	16			FDD
CA_7A-12B-66A	12			8	16			FDD
CA_7A-28A-40A	40			25	50	75	100	TDD
CA_8A-42A	8			8	16	25	25	FDD
CA_8A_11A_42A CA_8A_11A_42C	8			8	16	25	25	FDD
CA_11A-28A	28			12	25			FDD
CA_12A-30A-66A	12			8	16			FDD
CA_12A-66A	12	2	5	8	16	20	20	FDD
CA_13A-48A-66A CA_13A-48A-66A-66A CA_13A-48A-66B CA_13A-48A-66C CA_13A-48A-48A-66A CA_13A-48C-66A CA_13A-48D-66A CA_13A-48A-48C-66A CA_13A-48E-66A	66			12 <sup>1</sup>	25 <sup>1</sup>	36 <sup>1</sup>	50 <sup>1</sup>	FDD
CA_20A-32A-42A	20			8	16	25	25	FDD
CA_20A-40A <sup>3</sup> CA_20A-40D <sup>3</sup> CA_20A-38A-40A-40A <sup>3</sup> CA_20A-38A-40C <sup>3</sup>	40			25	50	75	100	TDD
CA_20A-40C <sup>3</sup>	40			25	50	75		TDD
CA_20A-40A-40A <sup>3</sup>	40			25	50	75		TDD
CA_20A-38A-40A <sup>3</sup>	40			25	50	75		TDD
CA_20A-38A-40D <sup>3</sup>	40			25	50	75		TDD
CA_20A-41A CA_20A-41C CA_20A-41D	20			8	16	25	25	FDD
CA_20A-42A, CA_20A-42A-42A	20			8	16	25	25	FDD
CA_28A-32A	28			12	25	36	50	FDD
CA_28A-40A	40			25	50	75	100	TDD
CA_28A-41A-42A	28				10	15	20	FDD
CA_28A-42A	28			5	10	15	20	FDD
CA_28A-66A	28			8	16	25	25	FDD
CA_48A-66A	66			12	25	36	50	FDD
CA_48A-48A-66A	66			12	25	36	50	FDD

CA_48A-48A-66A-66A	66			12	25	36	50	FDD
CA_48A-48A-66B	66			12	25	36	50	FDD
CA_48A-48A-66C	66			12	25	36	50	FDD
CA_48C-66A-66A	66			12	25	36	50	FDD
CA_48C-66B	66			12	25	36	50	FDD
CA_48C-66C	66			12	25	36	50	FDD
CA_48A-66A-66A	66			12 <sup>1</sup>	25 <sup>1</sup>	36 <sup>1</sup>	50 <sup>1</sup>	FDD
CA_48A-66B	66			12 <sup>1</sup>	25 <sup>1</sup>	36 <sup>1</sup>	50 <sup>1</sup>	FDD
CA_48A-66C	66			12 <sup>1</sup>	25 <sup>1</sup>	36 <sup>1</sup>	50 <sup>1</sup>	FDD
CA_48C-66A	66			12	25	36	50	FDD
CA_48E-66A	66			12	25	36	50	FDD
CA_66A-70A-71A	71			8	16	20		FDD
CA_66A-66A-70A-71A	71			8	16	20		FDD
CA_66A-70C-71A	71			8	16	20	20	FDD
CA_66A-66A-70C-71A	71			8	16	20	20	FDD
CA_66C-70A-71A	71			8	16	20		FDD
CA_66C-70C-71A	71			8	16	20	20	FDD
CA_70A-71A	71			8	16	20		FDD
CA_70C-71A	71			8	16	20	20	FDD
NOTE 1: refers to the UL resource blocks, which shall be centred within the transmission bandwidth configuration for the channel bandwidth.								
NOTE 2: the UL configuration applies regardless of the channel bandwidth of the low band unless the UL resource blocks exceed that specified in Table 7.3.1-2 for the uplink bandwidth in which case the allocation according to Table 7.3.1-2 applies.								
NOTE 3: <sup>3</sup> refers to the UL resource blocks shall be located between 2373-2400MHz.								
NOTE 4: These configurations apply when there is at least one individual RE within the uplink transmission bandwidth of a low band for which the 3rd transmitter harmonic is within the downlink transmission bandwidth of a high band.								
NOTE 5: These configurations apply when there is at least one individual RE within the uplink transmission bandwidth of a low band for which the 2nd transmitter harmonic is within the downlink transmission bandwidth of a high band.								

For the UE that supports any of the E-UTRA CA configurations given in Table 7.3.1A-0bA, exceptions to the requirements for a band(s) specified in subclause 7.3.1 are allowed when the band(s) is impacted by the uplink being active within a specified frequency range as noted in Table 7.3.1A-0bA. For these exceptions, the UE shall meet the requirements specified in Table 7.3.1A-0bA and Table 7.3.1A-0bB.



**Table 7.3.1A-0bA: Reference sensitivity for carrier aggregation QPSK  $P_{\text{REFSENS, CA}}$  (exceptions for two bands due to close proximity of UL to DL channel)**

EUTRA CA Configuration	EUTRA band	Channel bandwidth						Duplex mode
		1.4 MHz (dBm)	3 MHz (dBm)	5 MHz (dBm)	10 MHz (dBm)	15 MHz (dBm)	20 MHz (dBm)	
CA_1A-3A <sup>4</sup>	3 <sup>9</sup>		[-95.7]	-94	-91.5	-90	-89	FDD
CA_1A-3A <sup>5</sup>	3		-98.7	-97	-94	-92.2	-91	FDD
CA_1A-1A-3A <sup>4</sup>	3 <sup>9</sup>			-94	-91.5	-90	-89	FDD
CA_1A-1A-3A <sup>5</sup>	3			-97	-94	-92.2	-91	FDD
CA_1A-1A-3A-3A <sup>4</sup>	3 <sup>9</sup>		[-95.7]	-94	-91.5	-90	-89	FDD
CA_1A-1A-3A-3A <sup>5</sup>	3		-98.7	-97	-94	-92.2	-91	FDD
CA_1A-3A-3A <sup>4</sup>	3 <sup>9</sup>			-94	-91.5	-90	-89	FDD
CA_1A-3A-3A <sup>5</sup>	3			-97	-94	-92.2	-91	FDD
CA_1A-3C <sup>4</sup>	3 <sup>9</sup>			-94	-91.5	-90	-89	FDD
CA_1A-3C <sup>5</sup>	3			-97	-94	-92.2	-91	FDD
CA_1A-1A-3C <sup>4</sup>	3 <sup>9</sup>			-94	-91.5	-90	-89	FDD
CA_1A-1A-3C <sup>5</sup>	3			-97	-94	-92.2	-91	FDD
CA_1C-3A <sup>4</sup>	3 <sup>9</sup>			-94	-91.5	-90	-89	FDD
CA_1C-3A <sup>5</sup>	3			-97	-94	-92.2	-91	FDD
CA_18A-28A <sup>6</sup>	28			-94	-92.5			FDD
CA_19A-28A <sup>7</sup>	28			-94	-92			FDD

NOTE 1: The transmitter shall be set to  $P_{\text{UMAX}}$  as defined in subclause 6.2.5A.  
NOTE 2: Reference measurement channel is A.3.2 with one sided dynamic OCNG Pattern OP.1 FDD/TDD as described in Annex A.5.1.1/A.5.2.1  
NOTE 3: The signal power is specified per port  
NOTE 4: These requirements apply when the uplink is active in Band 1 and the separation between the lower edge of the uplink channel in Band 1 and the upper edge of the downlink channel in Band 3 is < 60 MHz. For each channel bandwidth in Band 3, the requirement applies regardless of channel bandwidth in Band 1.  
NOTE 5: These requirements apply when the uplink is active in Band 1 and the separation between the lower edge of the uplink channel in Band 1 and the upper edge of the downlink channel in Band 3 is  $\geq$  60 MHz. For each channel bandwidth in Band 3, the requirement applies regardless of channel bandwidth in Band 1.  
NOTE 6: These requirements apply when the uplink is active in Band 18 and the downlink channels in Band 28 are confined within the restricted frequency range specified for this CA configuration (Table 5.5A-2). For each channel bandwidth in Band 28, the requirement applies regardless of channel bandwidth in Band 18.  
NOTE 7: These requirements apply when the uplink is active in Band 19 and the downlink channels in Band 28 are allocated at the middle of the restricted frequency range specified for this CA configuration (Table 5.5A-2). For each channel bandwidth in Band 28, the requirement applies regardless of channel bandwidth in Band 19.  
NOTE 8: Void  
NOTE 9: Applicable for the operations with 2 or 4 antenna ports supported in the band with carrier aggregation configured.

**Table 7.3.1A-0bB: Uplink configuration for the uplink band (exceptions for two bands due to close proximity of UL to DL channel)**

E-UTRA Band / Channel bandwidth of the affected DL band / N <sub>RB</sub> / Duplex mode								
EUTRA CA Configuration	UL band	1.4 MHz	3 MHz	5 MHz	10 MHz	15 MHz	20 MHz	Duplex mode
CA_1A-3A <sup>1,2</sup>	1			25	25	25	25	FDD
CA_1A-3A <sup>1,3</sup>	1			25	45	45	45	FDD
CA_1A-1A-3A <sub>1,2</sub>	1			25	25	25	25	FDD
CA_1A-1A-3A <sub>1,3</sub>	1			25	45	45	45	FDD
CA_1A-1A-3A-3A <sup>1,2</sup>	1			25	25	25	25	FDD
CA_1A-1A-3A-3A <sup>1,3</sup>	1			25	45	45	45	FDD
CA_1A-3C <sup>1,2</sup>	1			25	25	25	25	FDD
CA_1A-3C <sup>1,3</sup>	1			25	45	45	45	FDD
CA_1A-1A-3C <sup>1,2</sup>	1			25	25	25	25	FDD
CA_1A-1A-3C <sup>1,3</sup>	1			25	45	45	45	FDD
CA_1C-3A <sup>1,2</sup>	1			25	25	25	25	FDD
CA_1C-3A <sup>1,3</sup>	1			25	45	45	45	FDD
CA_18A-28A <sup>4</sup>	18			18	18			FDD
CA_19A-28A <sup>4</sup>	19			18	18			FDD

NOTE 1: refers to the UL resource blocks shall be located as close as possible to the downlink channel in Band 3 but confined within the transmission bandwidth configuration for the channel bandwidth (Table 5.6-1) in the uplink channel in Band 1.

NOTE 2: UL allocation when the separation between the lower edge of the uplink channel in Band 1 and the upper edge of the downlink channel in Band 3 is < 60 MHz

NOTE 3: UL allocation when the separation between the lower edge of the uplink channel in Band 1 and the upper edge of the downlink channel in Band 3 is ≥ 60 MHz.

NOTE 4: refers to the UL resource blocks shall be located as close as possible to the downlink channel in Band 28 but confined within the transmission bandwidth configuration for the channel bandwidth (Table 5.6-1).

For the UE that supports any of the E-UTRA CA configurations given in Table 7.3.1A-0bC, exceptions to the requirements for a band(s) specified in subclause 7.3.1 are allowed when the band(s) is impacted by the uplink being active within a specified frequency range as noted in Table 7.3.1A-0bC. For these exceptions, the UE shall meet the requirements specified in Table 7.3.1A-0bC and Table 7.3.1A-0bD.

**Table 7.3.1A-0bC: Reference sensitivity for carrier aggregation QPSK  $P_{\text{REFSENS, CA}}$  (exceptions for three bands due to close proximity of UL to DL channel)**

Channel bandwidth								
EUTRA CA Configuration	EUTRA band	1.4 MHz (dBm)	3 MHz (dBm)	5 MHz (dBm)	10 MHz (dBm)	15 MHz (dBm)	20 MHz (dBm)	Duplex mode
CA_1A-3A-5A <sup>4</sup>	3 <sup>12</sup>			-94	-91.5	-90	-89	FDD
CA_1A-3A-5A <sup>5</sup>	3			-97	-94	-92.2	-91	FDD
CA_1A-1A-3A-5A <sup>4</sup>	3 <sup>12</sup>			-94	-91.5	-90	-89	FDD
CA_1A-1A-3A-5A <sup>5</sup>	3			-97	-94	-92.2	-91	FDD
CA_1A-1A-3C-5A <sup>4</sup>	3 <sup>12</sup>			-94	-91.5	-90	-89	FDD
CA_1A-1A-3C-5A <sup>5</sup>	3			-97	-94	-92.2	-91	FDD
CA_1A-3A-3A-5A <sup>4</sup>	3 <sup>9</sup>			-94	-91.5	-90	-89	FDD
CA_1A-3A-3A-5A <sup>5</sup>	3			-97	-94	-92.2	-91	FDD
CA_1C-3A-5A <sup>4</sup>	3 <sup>12</sup>			-94	-91.5	-90	-89	FDD
CA_1C-3A-5A <sup>5</sup>	3			-97	-94	-92.2	-91	FDD
CA_1A-3A-3A-7A-7A	3 <sup>4,12</sup>			-94	-91.5	-90	-89	FDD
	3 <sup>5</sup>			-97	-94	-92.2	-91	
CA_1A-3C-5A <sup>4</sup>	3 <sup>12</sup>			-94	-91.5	-90	-89	FDD
CA_1A-3C-5A <sup>5</sup>	3			-97	-94	-92.2	-91	FDD
CA_1A-3A-7A <sup>9</sup>	3 <sup>12</sup>			-94	-91.5	-90	-89	FDD
CA_1A-3A-7A <sup>10</sup>	3			-97	-94	-92.2	-91	FDD
CA_1A-1A-3A-7A <sup>9</sup>	3 <sup>12</sup>			-94	-91.5	-90	-89	FDD
CA_1A-1A-3A-7A <sup>10</sup>	3			-97	-94	-92.2	-91	FDD
CA_1A-3A-3A-7A	3 <sup>9,12</sup>			-94	-91.5	-90	-89	FDD
	3 <sup>10</sup>			-97	-94	-92.2	-91	
CA_1A-3A-7A-7A	3 <sup>9,12</sup>			-94	-91.5	-90	-89	FDD
	3 <sup>10</sup>			-97	-94	-92.2	-91	
CA_1A-3A-7C <sup>9</sup>	3 <sup>12</sup>				-91.5	-90	-89	FDD
CA_1A-3A-3A-7C <sup>9</sup>	3 <sup>12</sup>			-94	-91.5	-90	-89	FDD
CA_1A-3A-7C <sup>10</sup>	3				-94	-92.2	-91	FDD
CA_1A-3A-3A-7C <sup>10</sup>	3			-97	-94	-92.2	-91	FDD
CA_1A-3C-7A <sup>9</sup>	3 <sup>12</sup>			-94	-91.5	-90	-89	FDD
CA_1A-3C-7A <sup>10</sup>	3			-97	-94	-92.2	-91	FDD
CA_1A-1A-3C-7A <sup>9</sup>	3 <sup>12</sup>			-94	-91.5	-90	-89	FDD
CA_1A-1A-3C-7A <sup>10</sup>	3			-97	-94	-92.2	-91	FDD
CA_1A-3C-7C	3 <sup>9,12</sup>			-94	-91.5	-90	-89	FDD
	3 <sup>10</sup>			-97	-94	-92.2	-91	
CA_1A-3A-8A <sup>4</sup>	3 <sup>12</sup>			-94	-91.5	-90	-89	FDD
CA_1A-3A-8A <sup>5</sup>	3			-97	-94	-92.2	-91	FDD
CA_1A-3A-3A-8A <sup>4</sup>	3 <sup>12</sup>			-94	-91.5	-90	-89	FDD
CA_1A-3A-3A-8A <sup>5</sup>	3			-97	-94	-92.2	-91	FDD
CA_1A-3C-8A <sup>4</sup>	3 <sup>12</sup>			-94	-91.5	-90	-89	FDD
CA_1A-3C-8A <sup>5</sup>	3			-97	-94	-92.2	-91	FDD
CA_1A-3A-11A <sup>4</sup>	3 <sup>12</sup>			-94	-91.5	-90	-89	FDD
CA_1A-3A-11A <sup>5</sup>	3			-97	-94	-92.2	-91	FDD
CA_1A-3A-19A <sup>4</sup>	3 <sup>12</sup>			-94	-91.5	-90	-89	FDD
CA_1A-3A-19A <sup>5</sup>	3			-97	-94	-92.2	-91	FDD
CA_1A-3A-3A-19A <sup>4</sup>	3 <sup>12</sup>			-94	-91.5	-90	-89	FDD
CA_1A-3A-3A-19A <sup>5</sup>	3			-97	-94	-92.2	-91	FDD
CA_1A-3A-20A <sup>4</sup>	3 <sup>12</sup>			-94	-91.5	-90	-89	FDD
CA_1A-3A-3A-20A <sup>4</sup>								
CA_1A-3A-20A <sup>5</sup>	3			-97	-94	-92.2	-91	FDD
CA_1A-3A-3A-20A <sup>5</sup>								
CA_1A-3C-20A <sup>4</sup>	3 <sup>12</sup>			-94	-91.5	-90	-89	FDD
CA_1A-3C-20A <sup>5</sup>	3			-97	-94	-92.2	-91	FDD
CA_1A-3A-21A <sup>4</sup>	3 <sup>12</sup>			-94	-91.5	-90	-89	FDD
CA_1A-3A-21A <sup>5</sup>	3			-97	-94	-92.2	-91	FDD

CA_1A-3A-3A-21A <sup>4</sup>	3 <sup>12</sup>			-94	-91.5	-90	-89	FDD
CA_1A-3A-3A-21A <sup>5</sup>	3			-97	-94	-92.2	-91	FDD
CA_1A-3A-26A <sup>4</sup>	3 <sup>12</sup>			-94	-91.5	-90	-89	FDD
CA_1A-3A-26A <sup>5</sup>	3			-97	-94	-92.2	-91	FDD
CA_1A-3A-28A <sup>4</sup> CA_1A-1A-3A-28A <sup>4</sup> CA_1A-3A-3A-28A <sup>4</sup>	3 <sup>12</sup>			-94	-91.5	-90	-89	FDD
CA_1A-3A-28A <sup>5</sup> CA_1A-1A-3A-28A <sup>5</sup> CA_1A-3A-3A-28A <sup>5</sup>	3			-97	-94	-92.2	-91	FDD
CA_1A-3C-28A <sup>4</sup>	3 <sup>12</sup>			-94	-91.5	-90	-89	FDD
CA_1A-3C-28A <sup>5</sup>	3			-97	-94	-92.2	-91	FDD
CA_1A-3A-40A	3 <sup>4,12</sup>			-94	-91.5	-90	-89	FDD
	3 <sup>5</sup>			-97	-94	-92.2	-91	
	40			[-93.4]	-91.3	-90	-88.9	TDD
CA_1A-3A-40C	3 <sup>4,12</sup>			-94	-91.5	-90	-89	FDD
	3 <sup>5</sup>			-97	-94	-92.2	-91	
	40			[-93.4]	-91.3	-90	-88.9	TDD
CA_1A-3C-40A	3 <sup>4,12</sup>			-94	-91.5	-90	-89	FDD
	3 <sup>5</sup>			-97	-94	-92.2	-91	
	40			[-93.4]	-91.3	-90	-88.9	TDD
CA_1A-3C-40C	3 <sup>4,12</sup>			-94	-91.5	-90	-89	FDD
	3 <sup>5</sup>			-97	-94	-92.2	-91	
	40			[-93.4]	-91.3	-90	-88.9	TDD
CA_1A-3A-42A <sup>4</sup>	3 <sup>12</sup>			-93.8	-91.3	-89.8	-88.8	FDD
CA_1A-3A-42A <sup>5</sup>	3			-96.8	-93.8	-92	-90.8	FDD
CA_1A-3A-3A-42A <sup>4</sup>	3 <sup>12</sup>			-93.8	-91.3	-89.8	-88.8	FDD
CA_1A-3A-3A-42A <sup>5</sup>	3			-96.8	-93.8	-92	-90.8	FDD
CA_1A-3A-42A-42A <sup>4</sup>	3 <sup>12</sup>			-93.8	-91.3	-89.8	-88.8	FDD
CA_1A-3A-42A-42A <sup>5</sup>	3			-96.8	-93.8	-92	-90.8	FDD
CA_1A-3A-42A-42C <sup>4</sup>	3 <sup>12</sup>			-93.8	-91.3	-89.8	-88.8	FDD
CA_1A-3A-42A-42C <sup>5</sup>	3			-96.8	-93.8	-92	-90.8	FDD
CA_1A-3A-42C <sup>4</sup>	3 <sup>12</sup>			-93.8	-91.3	-89.8	-88.8	FDD
CA_1A-3A-42C <sup>5</sup>	3			-96.8	-93.8	-92	-90.8	FDD
CA_1A-3A-3A-42C <sup>4</sup>	3 <sup>12</sup>			-94	-91.5	-90	-89	FDD
CA_1A-3A-3A-42C <sup>5</sup>	3			-96.8	-93.8	-92	-90.8	FDD
CA_1A-3A-42C-42C <sup>4</sup>	3 <sup>12</sup>			-93.8	-91.3	-89.8	-88.8	FDD
CA_1A-3A-42C-42C <sup>5</sup>	3			-96.8	-93.8	-92	-90.8	FDD
CA_1A-3A-42D <sup>4</sup>	3 <sup>12</sup>			-93.8	-91.3	-89.8	-88.8	FDD
CA_1A-3A-42D <sup>5</sup>	3			-96.8	-93.8	-92	-90.8	FDD
CA_1A-18A-28A <sup>6</sup>	28			-94	-92.5			FDD
CA_1A-19A-28A <sup>8</sup>	28			-94	-92			FDD

NOTE 1:	The transmitter shall be set to $P_{UMAX}$ as defined in subclause 6.2.5A.
NOTE 2:	Reference measurement channel is A.3.2 with one sided dynamic OCNG Pattern OP.1 FDD/TDD as described in Annex A.5.1.1/A.5.2.1
NOTE 3:	The signal power is specified per port
NOTE 4:	These requirements apply when the uplink is active in Band 1 and the separation between the lower edge of the uplink channel in Band 1 and the upper edge of the downlink channel in Band 3 is < 60 MHz. For each channel bandwidth in the Bands other than Band 1, the requirement applies regardless of channel bandwidth in Band 1.
NOTE 5:	These requirements apply when the uplink is active in Band 1 and the separation between the lower edge of the uplink channel in Band 1 and the upper edge of the downlink channel in Band 3 is $\geq$ 60 MHz. For each channel bandwidth in the Bands other than Band 1, the requirement applies regardless of channel bandwidth in Band 1.
NOTE 6:	These requirements apply when the uplink is active in Band 18 and the downlink channels in Band 28 are confined within the restricted frequency range specified for this CA configuration (Table 5.5A-2). For each channel bandwidth in Band 28, the requirement applies regardless of channel bandwidth in Band 18.
NOTE 7:	Void
NOTE 8:	These requirements apply when the uplink is active in Band 19 and the downlink channels in Band 28 are allocated at the middle of the restricted frequency range specified for this CA configuration (Table 5.5A-2). For each channel bandwidth in Band 28, the requirement applies regardless of channel bandwidth in Band 19.
NOTE 9:	These requirements apply when the uplink is active in Band 1 and the separation between the lower edge of the uplink channel in Band 1 and the upper edge of the downlink channel in Band 3 is < 60 MHz. For each channel bandwidth in Band 3 and Band 7, the requirement applies regardless of channel bandwidth in Band 1.
NOTE 10:	These requirements apply when the uplink is active in Band 1 and the separation between the lower edge of the uplink channel in Band 1 and the upper edge of the downlink channel in Band 3 is $\geq$ 60 MHz. For each channel bandwidth in Band 3 and Band 7, the requirement applies regardless of channel bandwidth in Band 1.
NOTE 11:	Void
NOTE 12:	Applicable for the operations with 2 or 4 antenna ports supported in the band with carrier aggregation configured.

**Table 7.3.1A-0bD: Uplink configuration for the uplink band (exceptions for three bands due to close proximity of UL to DL channel)**

E-UTRA Band / Channel bandwidth of the affected DL band / N <sub>RB</sub> / Duplex mode								
EUTRA CA Configuration	UL band	1.4 MHz	3 MHz	5 MHz	10 MHz	15 MHz	20 MHz	Duplex mode
CA_1A-3A-5A <sup>1,2</sup>	1			25	25	25	25	FDD
CA_1A-3A-5A <sup>1,3</sup>	1			25	45	45	45	FDD
CA_1A-1A-3A-5A <sup>1,2</sup>	1			25	25	25	25	FDD
CA_1A-1A-3A-5A <sup>1,3</sup>	1			25	45	45	45	FDD
CA_1C-3A-5A <sup>1,2</sup>	1			25	25	25	25	FDD
CA_1C-3A-5A <sup>1,3</sup>	1			25	45	45	45	FDD
CA_1A-3A-3A-7A-7A	1 <sup>1,2</sup>			25	25	25	25	FDD
	1 <sup>1,3</sup>			25	45	45	45	
CA_1A-3C-5A <sup>1,2</sup>	1			25	25	25	25	FDD
CA_1A-3C-5A <sup>1,3</sup>	1			25	45	45	45	FDD
CA_1A-3A-7A <sup>1,2</sup>	1			25	25	25	25	FDD
CA_1A-3A-7A <sup>1,3</sup>	1			25	45	45	45	FDD
CA_1A-1A-3A-7A <sup>1,2</sup>	1			25	25	25	25	FDD
CA_1A-1A-3A-7A <sup>1,3</sup>	1			25	45	45	45	FDD
CA_1A-1A-3C-7A <sup>1,2</sup>	1			25	25	25	25	FDD
CA_1A-1A-3C-7A <sup>1,3</sup>	1			25	45	45	45	FDD
CA_1A-3A-3A-7A <sup>1,2</sup>	1			25	25	25	25	FDD
CA_1A-3A-3A-7C <sup>1,2</sup>	1			25	25	25	25	FDD
CA_1A-3A-3A-7A <sup>1,3</sup>	1			25	45	45	45	FDD
CA_1A-3A-3A-7C <sup>1,3</sup>	1			25	45	45	45	FDD
CA_1A-3A-7A-7A <sup>1,2</sup>	1			25	25	25	25	FDD
CA_1A-3A-7A-7A <sup>1,3</sup>	1			25	45	45	45	FDD
CA_1A-3C-7A <sup>1,2</sup>	1			25	25	25	25	FDD
CA_1A-3C-7A <sup>1,3</sup>	1			25	45	45	45	FDD
CA_1A-3A-7C <sup>1,2</sup>	1			25	25	25	25	FDD
CA_1A-3A-7C <sup>1,3</sup>	1			25	45	45	45	FDD
CA_1A-3C-7C <sup>1,2</sup>	1			25	25	25	25	FDD
CA_1A-3C-7C <sup>1,3</sup>	1			25	45	45	45	FDD
CA_1A-3A-8A <sup>1,2</sup>	1			25	25	25	25	FDD
CA_1A-3A-8A <sup>1,3</sup>	1			25	45	45	45	FDD
CA_1A-3A-3A-8A <sup>1,2</sup>	1			25	25	25	25	FDD
CA_1A-3A-3A-8A <sup>1,3</sup>	1			25	45	45	45	FDD
CA_1A-3C-8A <sup>1,2</sup>	1			25	25	25	25	FDD
CA_1A-3C-8A <sup>1,3</sup>	1			25	45	45	45	FDD
CA_1A-3A-11A <sup>1,2</sup>	1			25	25	25	25	FDD
CA_1A-3A-11A <sup>1,3</sup>	1			25	45	45	45	FDD
CA_1A-3A-19A <sup>1,2</sup>	1			25	25	25	25	FDD
CA_1A-3A-19A <sup>1,3</sup>	1			25	45	45	45	FDD
CA_1A-3A-3A-19A <sup>1,2</sup>	1			25	25	25	25	FDD
CA_1A-3A-3A-19A <sup>1,3</sup>	1			25	45	45	45	FDD
CA_1A-3A-20A <sup>1,2</sup>	1			25	25	25	25	FDD
CA_1A-3A-3A-20A <sup>1,2</sup>	1			25	25	25	25	FDD
CA_1A-3A-20A <sup>1,3</sup>	1			25	45	45	45	FDD
CA_1A-3A-3A-20A <sup>1,3</sup>	1			25	45	45	45	FDD
CA_1A-3C-20A <sup>1,2</sup>	1			25	25	25	25	FDD
CA_1A-3C-20A <sup>1,3</sup>	1			25	45	45	45	FDD
CA_1A-3A-21A <sup>1,2</sup>	1			25	25	25	25	FDD
CA_1A-3A-21A <sup>1,3</sup>	1			25	45	45	45	FDD
CA_1A-3A-3A-21A <sup>1,2</sup>	1			25	25	25	25	FDD
CA_1A-3A-3A-21A <sup>1,3</sup>	1			25	45	45	45	FDD
CA_1A-3A-26A <sup>1,2</sup>	1			25	25	25	25	FDD
CA_1A-3A-26A <sup>1,3</sup>	1			25	45	45	45	FDD



CA_1A-3A-28A <sup>1,2</sup> CA_1A-1A-3A-28A <sup>1,2</sup> CA_1A-3A-3A-28A <sup>1,2</sup>	1			25	25	25	25	FDD
CA_1A-3A-28A <sup>1,3</sup> CA_1A-1A-3A-28A <sup>1,3</sup> CA_1A-3A-3A-28A <sup>1,3</sup>	1			25	45	45	45	FDD
CA_1A-3C-28A <sup>1,2</sup>	1			25	25	25	25	FDD
CA_1A-3C-28A <sup>1,3</sup>	1			25	45	45	45	FDD
CA_1A-3A-40A CA_1A-3A-40C CA_1A-3C-40A CA_1A-3C-40C	1 <sup>1,2</sup> 1 <sup>1,3</sup>			25	25	25	25	FDD
CA_1A-3A-42A <sup>1,2</sup>	1			25	25	25	25	FDD
CA_1A-3A-42A <sup>1,3</sup>	1			25	45	45	45	FDD
CA_1A-3A-3A-42A <sup>1,2</sup>	1			25	25	25	25	FDD
CA_1A-3A-3A-42A <sup>1,3</sup>	1			25	45	45	45	FDD
CA_1A-3A-42A-42A <sup>1,2</sup>	1			25	25	25	25	FDD
CA_1A-3A-42A-42A <sup>1,3</sup>	1			25	45	45	45	FDD
CA_1A-3A-42A-42C <sup>1,2</sup>	1			25	25	25	25	FDD
CA_1A-3A-42A-42C <sup>1,3</sup>	1			25	45	45	45	FDD
CA_1A-3A-42C-42C <sup>1,2</sup>	1			25	25	25	25	FDD
CA_1A-3A-42C-42C <sup>1,3</sup>	1			25	45	45	45	FDD
CA_1A-3A-42D <sup>1,2</sup>	1			25	25	25	25	FDD
CA_1A-3A-42D <sup>1,3</sup>	1			25	45	45	45	FDD
CA_1A-3A-3A-42C <sup>1,2</sup>	1			25	25	25	25	FDD
CA_1A-3A-3A-42C <sup>1,3</sup>	1			25	45	45	45	FDD
CA_1A-18A-28A <sup>4</sup>	18			18	18			FDD
CA_1A-19A-28A <sup>4</sup>	19			18	18			FDD
NOTE 1: refers to the UL resource blocks shall be located as close as possible to the downlink channel in Band 3 but confined within the transmission bandwidth configuration for the channel bandwidth (Table 5.6-1) in the uplink channel in Band 1.								
NOTE 2: UL allocation when the separation between the lower edge of the uplink channel in Band 1 and the upper edge of the downlink channel in Band 3 is < 60 MHz								
NOTE 3: UL allocation when the separation between the lower edge of the uplink channel in Band 1 and the upper edge of the downlink channel in Band 3 is ≥ 60 MHz.								
NOTE 4: refers to the UL resource blocks shall be located as close as possible to the downlink channel in Band 28 but confined within the transmission bandwidth configuration for the channel bandwidth (Table 5.6-1).								

For the UE that supports any of the E-UTRA CA configurations given in Table 7.3.1A-0bD1, exceptions to the requirements for a band(s) specified in subclause 7.3.1 are allowed when the band(s) is impacted by the uplink being active within a specified frequency range as noted in Table 7.3.1A-0bD1. For these exceptions, the UE shall meet the requirements specified in Table 7.3.1A-0bD1 and Table 7.3.1A-0bD2.

**Table 7.3.1A-0bD1: Reference sensitivity for carrier aggregation QPSK  $P_{\text{REFSENS, CA}}$  (exceptions for four bands due to close proximity of UL to DL channel)**

Channel bandwidth								
EUTRA CA Configuration	EUTRA band	1.4 MHz (dBm)	3 MHz (dBm)	5 MHz (dBm)	10 MHz (dBm)	15 MHz (dBm)	20 MHz (dBm)	Duplex mode
CA_1A-3A-5A-7A CA_1A-3A-3A-5A-7A CA_1A-3A-5A-7A-7A	3 <sup>4,9</sup> 3 <sup>5</sup>			-94 -97	-91.5 -94	-90 -92.2	-89 -91	FDD
CA_1A-3A-5A-28A	3 <sup>4,9</sup> 3 <sup>5</sup>			-94 -97	-91.5 -94	-90 -92.2	-89 -91	FDD
CA_1A-3A-5A-40A	3 <sup>4,9</sup> 3 <sup>5</sup> 40			-94 -97	-91.5 -94 -91.9	-90 -92.2 -90.4	-89 -91 -89.4	FDD TDD
CA_1A-3A-5A-41A <sup>7,8</sup>	3 <sup>4,9</sup> 3 <sup>5</sup> 41			-94 -97	-91.5 -94	-90 -92.2	-89 -91 [88.1]	FDD TDD
CA_1A-3C-7A-8A CA_1A-3A-3A-7A-8A CA_1A-3A-7A-7A-8A CA_1A-3A-3A-7A-7A-8A	3 <sup>4,9</sup> 3 <sup>5</sup>			-94 -97	-91.5 -94	-90 -92.2	-89 -91	FDD
CA_1A-3C-7A-20A	3 <sup>4,9</sup> 3 <sup>5</sup>			-94 -97	-91.5 -94	-90 -92.2	-89 -91	FDD
CA_1A-3A-7A-7A-26A	3 <sup>4,9</sup> 3 <sup>5</sup>			-97	-94	-92.2	-91	FDD
CA_1A-3A-7A-8A	3 <sup>4,9</sup> 3 <sup>5</sup>			-94 -97	-91.5 -94	-90 -92.2	-89 -91	FDD
CA_1A-3A-7A-20A	3 <sup>4,9</sup> 3 <sup>5</sup>			-94 -97	-91.5 -94	-90 -92.2	-89 -91	FDD
CA_1A-3A-3A-7A-20A CA_1A-3A-7A-7A-20A	3 <sup>4,9</sup> 3 <sup>5</sup>			-94 -97	-91.5 -94	-90 -92.2	-89 -91	FDD
CA_1A-3A-7A-26A	3 <sup>4,9</sup> 3 <sup>5</sup>			-97	-94	-92.2	-91	FDD
CA_1A-3A-7A-28A	3 <sup>4,9</sup> 3 <sup>5</sup>				[-91.5] -94	[-90] -92.2	[-89] -91	FDD
CA_1A-3A-7C-28A CA_1A-1A-3A-7A-28A CA_1A-1A-3A-7C-28A CA_1A-1A-3C-7A-28A CA_1A-1A-3C-7C-28A CA_1A-3A-3A-7C-28A CA_1A-1A-3A-3A-7A-28A CA_1A-1A-3A-3A-7C-28A	3 <sup>4,9</sup> 3 <sup>5</sup>				[-91.5] -94	[-90] -92.2	[-89] -91	FDD
CA_1A-3A-7A-38A CA_1A-3C-7A-38A	3 <sup>6,9</sup> 3 <sup>5</sup>			-93.8 -96.8	-91.3 -93.8	-89.8 -92	-88.8 -90.8	FDD
CA_1A-3A-7A-42A	3 <sup>4,9</sup> 3 <sup>5</sup>			-93.8 -96.8	-91.3 -93.8	-89.8 -92	-88.8 -90.8	FDD
CA_1A-3A-8A-11A	3 <sup>4,9</sup> 3 <sup>5</sup>			-94 -97	-91.5 -94	-90 -92.2	-89 -91	FDD

CA_1A-3A-8A-28A	3 <sup>4,9</sup>			-94	-91.5	-90	-89	FDD
	3 <sup>5</sup>			-97	-94	-92.2	-91	
CA_1A-3A-8A-38A	3 <sup>4,9</sup>			-94	-91.5	-90	-89	FDD
	3 <sup>5</sup>			-97	-94	-92.2	-91	
CA_1A-3A-11A-28A	3 <sup>4,9</sup>			-94	-91.5	-90	-89	FDD
	3 <sup>5</sup>			-97	-94	-92.2	-91	
CA_1A-3A-8A-40A	3 <sup>4,9</sup>			-94	-91.5	-90	-89	FDD
	3 <sup>5</sup>			-97	-94	-92.2	-91	
	40			[-93.4]	-91.9	-90.4	-89.4	TDD
CA_1A-3A-8A-42A	3 <sup>4,9</sup>			-93.8	-91.3	-89.8	-88.8	FDD
CA_1A-3A-8A-42C	3 <sup>5</sup>			-96.8	-93.8	-92	-90.8	
CA_1A-3A-18A-42A	3 <sup>4,9</sup>			-93.8	-91.3	-89.8	-88.8	FDD
CA_1A-3A-18A-42C	3 <sup>5</sup>			-96.8	-93.8	-92	-90.8	
CA_1A-3A-19A-21A <sup>4</sup>	3 <sup>9</sup>			-93.7	-91.2	-89.7	-88.7	FDD
CA_1A-3A-19A-21A <sup>5</sup>	3			-96.7	-93.7	-91.9	-90.7	FDD
CA_1A-3A-3A-19A-21A <sup>4</sup>	3 <sup>9</sup>			-93.7	-91.2	-89.7	-88.7	FDD
CA_1A-3A-3A-19A-21A <sup>5</sup>	3			-96.7	-93.7	-91.9	-90.7	FDD
CA_1A-3A-7A-40C <sup>4</sup>	3 <sup>9</sup>			-94	-91.5	-90	-89	FDD
	40			-92.6	-90.5	-89.2	-88.1	TDD
CA_1A-3A-7A-40C <sup>5</sup>	3			-97	-94	-92.2	-91	FDD
	40			-92.6	-90.5	-89.2	-88.1	TDD
CA_1A-3A-19A-42A	3 <sup>4,9</sup>			-93.8	-91.3	-89.8	-88.8	FDD
	3 <sup>5</sup>			-96.8	-93.8	-92	-90.8	
CA_1A-3A-19A-42C	3 <sup>4,9</sup>			-93.8	-91.3	-89.8	-88.8	FDD
	3 <sup>5</sup>			-96.8	-93.8	-92	-90.8	
CA_1A-3A-20A-28A	3 <sup>4,9</sup>			-94	-91.5	-90	-89	FDD
	3 <sup>5</sup>			-97	-94	-92.2	-91	
CA_1A-3A-3A-20A-28A	3 <sup>4,9</sup>			-94	-91.5	-90	-89	FDD
	3 <sup>5</sup>			-97	-94	-92.2	-91	FDD
CA_1A-3A-20A-42A	3 <sup>4,9</sup>			-93.8	-91.3	-89.8	-88.8	FDD
	3 <sup>5</sup>			-96.8	-93.8	-92	-90.8	
CA_1A-3A-20A-43A	3 <sup>4,9</sup>			-94	-91.5	-90		FDD
	3 <sup>5</sup>			-97	-94	-92.2		
CA_1A-3A-21A-28A <sup>4</sup>	3 <sup>9</sup>			-93.7	-91.2	-89.7	-88.7	FDD
CA_1A-3A-21A-28A <sup>5</sup>	3			-96.7	-93.7	-91.9	-90.7	FDD
CA_1A-3A-21A-42A <sup>4</sup>	3 <sup>9</sup>			-93.7	-91.2	-89.7	-88.7	FDD
CA_1A-3A-21A-42A <sup>5</sup>	3			-96.7	-93.7	-91.9	-90.7	FDD
CA_1A-3A-21A-42C	3 <sup>4,9</sup>			-93.7	-91.2	-89.7	-88.7	FDD
	3 <sup>5</sup>			-96.7	-93.7	-91.9	-90.7	
CA_1A-3A-28A-40A	3 <sup>4,9</sup>			-94	-91.5	-90	-89	FDD
	3 <sup>5</sup>			-97	-94	-92.2	-91	
	40			[-93.4]	-91.9	-90.4	-89.4	TDD
CA_1A-3A-28A-40C	3 <sup>4,9</sup>			-94	-91.5	-90	-89	FDD
	3 <sup>5</sup>			-97	-94	-92.2	-91	
CA_1A-3A-28A-42A <sup>4</sup>	3 <sup>9</sup>			-93.8	-91.3	-89.8	-88.8	FDD
	40			-92.6	-90.5	-89.2	-88.1	
CA_1A-3A-28A-42A <sup>5</sup>	3			-96.8	-93.8	-92	-90.8	FDD

CA_1A-3A-28A-42C	3 <sup>4,9</sup>			-93.8	-91.3	-89.8	-88.8	FDD
	3 <sup>5</sup>			-96.8	-93.8	-92	-90.8	
CA_1A-3A-32A-42A	3 <sup>4,9</sup>			-93.8	-91.3	-89.8		FDD
	3 <sup>5</sup>			-96.8	-93.8	-92		
CA_1A-3A-32A-43A	3 <sup>4,9</sup>			-94	-91.5	-90		FDD
	3 <sup>5</sup>			-97	-94	-92.2		
CA_1A-3A-41A-42A CA_1A-3A-41C-42A CA_1A-3A-41A-42C CA_1A-3A-41C-42C	3 <sup>4,9</sup>			-93.8	-91.3	-89.8	-88.8	FDD
	3 <sup>5</sup>			-96.8	-93.8	-92	-90.8	
CA_1A-3A-42A-43A	3 <sup>4,9</sup>			-93.8	-91.3	-89.8		FDD
	3 <sup>5</sup>			-96.8	-93.8	-92		
NOTE 1: The transmitter shall be set to P <sub>UMAX</sub> as defined in subclause 6.2.5A.								
NOTE 2: Reference measurement channel is A.3.2 with one sided dynamic OCNG Pattern OP.1 FDD/TDD as described in Annex A.5.1.1/A.5.2.1								
NOTE 3: The signal power is specified per port								
NOTE 4: These requirements apply when the uplink is active in Band 1 and the separation between the lower edge of the uplink channel in Band 1 and the upper edge of the downlink channel in Band 3 is < 60 MHz. For each channel bandwidth in the bands other than Band 1, the requirement applies regardless of channel bandwidth in Band 1.								
NOTE 5: These requirements apply when the uplink is active in Band 1 and the separation between the lower edge of the uplink channel in Band 1 and the upper edge of the downlink channel in Band 3 is ≥ 60 MHz. For each channel bandwidth in the bands other than Band 1, the requirement applies regardless of channel bandwidth in Band 1.								
NOTE 6: Void								
NOTE 7: The Band 41 requirements are modified by -0.5dB when carrier frequency of the assigned E-UTRA channel bandwidth is within 2545-2690MHz.								
NOTE 8: The Band 41 requirements also apply to the supported CA_1A-41A.								
NOTE 9: Applicable for the operations with 2 or 4 antenna ports supported in the band with carrier aggregation configured.								

**Table 7.3.1A-0bD2: Uplink configuration for the low band (exceptions for four bands due to close proximity of UL to DL channel)**

E-UTRA Band / Channel bandwidth of the affected DL band / N <sub>RB</sub> / Duplex mode								
EUTRA CA Configuration	UL band	1.4 MHz	3 MHz	5 MHz	10 MHz	15 MHz	20 MHz	Duplex mode
	1 <sup>1,2</sup>			25	25	25	25	FDD

CA_1A-3A-5A-7A							
CA_1A-3A-3A-5A-7A							
CA_1A-3A-5A-7A-7A							
CA_1A-3A-5A-28A							
CA_1A-3A-5A-40A							
CA_1A-3A-5A-41A							
CA_1A-3A-7A-7A-26A							
CA_1A-3A-7A-8A							
CA_1A-3C-7A-8A							
CA_1A-3A-3A-7A-8A							
CA_1A-3A-7A-7A-8A							
CA_1A-3A-3A-7A-7A-8A							
CA_1A-3A-7A-20A							
CA_1A-3C-7A-20A							
CA_1A-3A-3A-7A-20A							
CA_1A-3A-7A-7A-20A							
CA_1A-3A-7A-26A							
CA_1A-3A-7A-28A							
CA_1A-3A-7C-28A							
CA_1A-1A-3A-7A-28A							
CA_1A-1A-3A-7C-28A							
CA_1A-1A-3C-7A-28A							
CA_1A-1A-3C-7C-28A	1 <sup>1,3</sup>		25	45	45	45	
CA_1A-3A-3A-7C-28A							
CA_1A-1A-3A-3A-7A-28A							
CA_1A-1A-3A-3A-7C-28A							
CA_1A-3A-7A-38A							
CA_1A-3C-7A-38A							
CA_1A-3A-7A-40C							
CA_1A-3A-7A-42A							
CA_1A-3A-8A-11A							
CA_1A-3A-8A-28A							
CA_1A-3A-8A-38A							
CA_1A-3A-11A-28A							
CA_1A-3A-8A-40A							
CA_1A-3A-8A-42A							
CA_1A-3A-8A-42C							
CA_1A-3A-18A-42A							
CA_1A-3A-18A-42C							
CA_1A-3A-19A-21A							
CA_1A-3A-3A-19A-21A							
CA_1A-3A-19A-42A							
CA_1A-3A-19A-42C							
CA_1A-3A-20A-28A							
CA_1A-3A-3A-20A-28A							
CA_1A-3A-20A-42A							
CA_1A-3A-20A-43A							
CA_1A-3A-21A-28A							
CA_1A-3A-21A-42A							
CA_1A-3A-21A-42C							
CA_1A-3A-28A-40A							



CA_1A-3A-28A-40C								
CA_1A-3A-28A-42A								
CA_1A-3A-32A-42A								
CA_1A-3A-32A-43A								
CA_1A-3A-41A-42A								
CA_1A-3A-41C-42A								
CA_1A-3A-41A-42C								
CA_1A-3A-41C-42C								
CA_1A-3A-42A-43A								

NOTE 1: refers to the UL resource blocks shall be located as close as possible to the downlink channel in Band 3 but confined within the transmission bandwidth configuration for the channel bandwidth (Table 5.6-1) in the uplink channel in Band 1.

NOTE 2: UL allocation when the separation between the lower edge of the uplink channel in Band 1 and the upper edge of the downlink channel in Band 3 is < 60 MHz

NOTE 3: UL allocation when the separation between the lower edge of the uplink channel in Band 1 and the upper edge of the downlink channel in Band 3 is  $\geq$  60 MHz.

For the UE that supports any of the E-UTRA CA configurations given in Table 7.3.1A-0bD1, exceptions are allowed when the uplink is active within a specified frequency range as noted in Table 7.3.1A-0bD1. For these exceptions, the UE shall meet the requirements specified in Table 7.3.1A-0bD1 and Table 7.3.1A-0bD2.

**Table 7.3.1A-0bD3: Reference sensitivity for carrier aggregation QPSK  $P_{\text{REFSENS, CA}}$  (exceptions for five bands due to close proximity of UL to DL channel)**

EUTRA CA Configuration	EUTRA band	Channel bandwidth						Duplex mode
		1.4 MHz (dBm)	3 MHz (dBm)	5 MHz (dBm)	10 MHz (dBm)	15 MHz (dBm)	20 MHz (dBm)	
CA_1A-3A-5A-7A-28A	3 <sup>4,9</sup>			-94	-91.5	-90	-89	FDD
	3 <sup>5</sup>			-97	-94	-92.2	-91	
CA_1A-3A-7A-8A-20A	3 <sup>4,7</sup>			-94	-91.5	-90	-89	FDD
	3 <sup>5</sup>			-97	-94	-92.2	-91	
CA_1A-3A-7A-20A-28A	3 <sup>4,7</sup>			-94	-91.5	-90	-89	FDD
	3 <sup>5</sup>			-97	-94	-92.2	-91	
CA_1A-3A-7A-20A-42A	3 <sup>4,7</sup>			-93.8	-91.3	-89.8	-88.8	FDD
	3 <sup>5</sup>			-96.8	-93.8	-92	-90.8	
CA_1A-3A-20A-32A-42A	3 <sup>4,7</sup>			-93.8	-91.3	-89.8		FDD
	3 <sup>5</sup>			-96.8	-93.8	-92		
CA_1A-3A-20A-32A-43A	3 <sup>4,7</sup>			-94	-91.5	-90		FDD
	3 <sup>5</sup>			-97	-94	-92.2		
CA_1A-3A-32A-42A-43A	3 <sup>4,7</sup>			-93.8	-91.3	-89.8		FDD
	3 <sup>5</sup>			-96.8	-93.8	-92		

NOTE 1: The transmitter shall be set to  $P_{\text{UMAX}}$  as defined in subclause 6.2.5A.

NOTE 2: Reference measurement channel is A.3.2 with one sided dynamic OCNG Pattern OP.1 FDD/TDD as described in Annex A.5.1.1/A.5.2.1

NOTE 3: The signal power is specified per port

NOTE 4: These requirements apply when the uplink is active in Band 1 and the separation between the lower edge of the uplink channel in Band 1 and the upper edge of the downlink channel in Band 3 is < 60 MHz. For each channel bandwidth in the bands other than Band 1, the requirement applies regardless of channel bandwidth in Band 1.

NOTE 5: These requirements apply when the uplink is active in Band 1 and the separation between the lower edge of the uplink channel in Band 1 and the upper edge of the downlink channel in Band 3 is  $\geq$  60 MHz. For each channel bandwidth in the bands other than Band 1, the requirement applies regardless of channel bandwidth in Band 1.

NOTE 6: Void

NOTE 7: Applicable for the operations with 2 or 4 antenna ports supported in the band with carrier aggregation configured.

**Table 7.3.1A-0bD4: Uplink configuration for the low band (exceptions for five bands due to close proximity of UL to DL channel)**

E-UTRA Band / Channel bandwidth / N <sub>RB</sub> / Duplex mode								
EUTRA CA Configuration	UL band	1.4 MHz	3 MHz	5 MHz	10 MHz	15 MHz	20 MHz	Duplex mode
CA_1A-3A-5A-7A-28A	1 <sup>1,2</sup>			25	25	25	25	FDD
CA_1A-3A-7A-8A-20A	1 <sup>1,3</sup>							
CA_1A-3A-7A-20A-28A								
CA_1A-3A-7A-20A-42A				25	45	45	45	
CA_1A-3A-20A-32A-42A								
CA_1A-3A-20A-32A-43A								
CA_1A-3A-32A-42A-43A								
<p>NOTE 1: refers to the UL resource blocks shall be located as close as possible to the downlink channel in Band 3 but confined within the transmission bandwidth configuration for the channel bandwidth (Table 5.6-1) in the uplink channel in Band 1.</p> <p>NOTE 2: UL allocation when the separation between the lower edge of the uplink channel in Band 1 and the upper edge of the downlink channel in Band 3 is &lt; 60 MHz.</p> <p>NOTE 3: UL allocation when the separation between the lower edge of the uplink channel in Band 1 and the upper edge of the downlink channel in Band 3 is ≥ 60 MHz.</p>								

For the UE that supports any of the E-UTRA CA configurations given in Table 7.3.1A-0bE, exceptions to the requirements for a band(s) specified in subclause 7.3.1 are allowed when the band(s) is impacted by uplink being active in the applicable active UL bands of the same CA configuration in Table 7.3.1A-0bE. For these exceptions, the UE shall meet the reference sensitivities specified in Table 7.3.1A-0bE and Table 7.3.1A-0bF.

**Table 7.3.1A-0bE: Reference sensitivity for carrier aggregation QPSK  $P_{\text{REFSENS, CA}}$  (exceptions due to cross band isolation issues of TDD and FDD bands)**

EUTRA CA Configuration	EUTRA band	Channel bandwidth						Duplex mode	Applicable active UL band
		1.4 MHz (dBm)	3 MHz (dBm)	5 MHz (dBm)	10 MHz (dBm)	15 MHz (dBm)	20 MHz (dBm)		
CA_1A-3A-5A-40A	40 <sup>19</sup>				-92.9	-91.3	-90.2	TDD	3
CA_1A-3A-5A-40A	1 <sup>19</sup>			-91.7	[-89.5]	[-87.9]	[-86.9]	FDD	40
	3 <sup>19</sup>			-94.2	-91.2	-89.5	-88.3		
CA_1A-3A-5A-41A <sup>5</sup>	41						[-88.1]	TDD	3
CA_1A-3A-7A-20A-42A	42 <sup>19</sup>			-95.6	-93	-91.5	-90.4	TDD	7
CA_1A-3A-7A-20A-42A	7 <sup>19</sup>				-93	-91.3	-90.1	FDD	42
CA_1A-3A-7A-38A CA_1A-3C-7A-38A	7 <sup>19</sup>			-93.3	-90.7	-89.2	-88.1	FDD	1
	38 <sup>19</sup>			-93.3	-90.7	-89.2	-88.1	TDD	
CA_1A-3A-7A-38A CA_1A-3C-7A-38A	7 <sup>19</sup>			-93.3	-90.7	-89.2	-88.1	FDD	3
	38 <sup>19</sup>			-93.3	-90.7	-89.2	-88.1	TDD	
CA_1A-3A-7A-40A <sup>15</sup>	3 <sup>19</sup>			-94	-91.5	-90	-89	FDD	1
	40 <sup>19</sup>			-92.6	-90.5	-89.2	-88.1	TDD	
CA_1A-3A-7A-40A <sup>16</sup>	3			-97	-94	-92.2	-91	FDD	1
	40 <sup>19</sup>			-92.6	-90.5	-89.2	-88.1	TDD	
CA_1A-3A-7A-40A	40 <sup>19</sup>			-94.6	-92.1	-90.5	-89.4	TDD	3
CA_1A-3A-7A-40A	40 <sup>19</sup>			-96	-93.3	-91.7	-90.6	TDD	7
CA_1A-3A-7A-40A	1 <sup>19</sup>			-91.7	-89.5	-87.9	-86.9	FDD	40
	3 <sup>19</sup>			-94.2	-91.2	-89.5	-88.3		
	7 <sup>19</sup>			-94	-92.4	-91.2			
CA_1A-3A-7A-40C	40			-94.6	-92.1	-90.5	-89.4	TDD	3
CA_1A-3A-7A-40C	40			-96	-93.3	-91.7	-90.6	TDD	7
CA_1A-3A-7A-40C	1			-91.7	-89.5	-87.9	-86.9	FDD	40
	3			-94.2	-91.2	-89.5	-88.3		
	7			-94	-92.4	-91.2			
CA_1A-3A-7A-42A	42 <sup>19</sup>			-95.6	-93	-91.5	-90.4	TDD	7
	7 <sup>19</sup>				-93	-91.3	-90.1	FDD	42
	42			-98.5	-95.5	-93.7	-92.5	TDD	
CA_1A-3A-8A-40A	40 <sup>19</sup>			-95.4	-92.9	-91.3	-90.2	TDD	3
CA_1A-3A-8A-40A	1 <sup>19</sup>			-91.7	[-89.5]	[-87.9]	[-86.9]	FDD	40
	3 <sup>19</sup>			-94.2	-91.2	-89.5	-88.3		
CA_1A-3A-28A-40A CA_1A-3A-28A-40C	1 <sup>19</sup>			-91.7	[-89.5]	[-87.9]	[-86.9]	FDD	40
	3 <sup>19</sup>			-94.2	-91.2	-89.5	-88.3	FDD	
	28			-96.8	-94.1	-92.5	-89.8	FDD	
CA_1A-3A-28A-40A CA_1A-3A-28A-40C	40 <sup>19</sup>			[-93.4]	-91.9	-90.4	-89.4	TDD	1
CA_1A-3A-28A-40A CA_1A-3A-28A-40C	40 <sup>19</sup>			-94.6	-92.1	-90.5	-89.4	TDD	3
CA_1A-3A-28A-40A CA_1A-3A-28A-40C	40 <sup>19</sup>			-95.1	-92.9	-91.4	-90.5	TDD	28
CA_1A-3A-38A <sup>12</sup> CA_1A-3C-38A <sup>12</sup>	3 <sup>19</sup>			-94	-91.5	-90	-89	FDD	1
	38			-97.1	-94.4	-92.8	-91.7	TDD	
	38			-97.1	-94.4	-92.8	-91.7	TDD	
	1 <sup>19</sup>			-98.1	-95.1	-93.3	-92.1	FDD	
	3 <sup>19</sup>			-95.1	-92.1	-90.3	-89.1	FDD	
CA_1A-3A-38A <sup>13</sup> CA_1A-3C-38A <sup>13</sup>	3			-97	-94	-92.2	-91	FDD	1
	38			-97.1	-94.4	-92.8	-91.7	TDD	
	38			-97.1	-94.4	-92.8	-91.7	TDD	
	1 <sup>19</sup>			-98.1	-95.1	-93.3	-92.1	FDD	
	3 <sup>19</sup>			-95.1	-92.1	-90.3	-89.1	FDD	
CA_1A-3A-40A	40 <sup>19</sup>			-100	-92.9	-91.3	-90.2	TDD	3

CA_1A-3A-40A	1 <sup>19</sup>			-91.7	[-89.5]	[-87.9]	[-86.9]	FDD	40
	3 <sup>19</sup>			-94.2	-91.2	-89.5	-88.3		
CA_1A-3A-40C	40 <sup>19</sup>			-100	-92.9	-91.3	-90.2	TDD	3
CA_1A-3A-40C	1 <sup>19</sup>			-91.7	[-89.5]	[-87.9]	[-86.9]	FDD	40
	3 <sup>19</sup>			-94.2	-91.2	-89.5	-88.3		
CA_1A-3C-40A	40 <sup>19</sup>			-100	-92.9	-91.3	-90.2	TDD	3
CA_1A-3C-40A	1 <sup>19</sup>			-91.7	[-89.5]	[-87.9]	[-86.9]	FDD	40
	3 <sup>19</sup>			-94.2	-91.2	-89.5	-88.3		
CA_1A-3A-41A <sup>12,14</sup> CA_1A-3A-41C <sup>12,14</sup> CA_1A-3A-41D <sup>12,14</sup>	3 <sup>19</sup>			-94	-91.5	-90	-89	FDD	1
	41 <sup>19</sup>			-93.3	-90.7	-89.2	-88.1	TDD	
	41 <sup>19</sup>			-93.3	-90.7	-89.2	-88.1	TDD	
CA_1A-3A-41A <sup>13,14</sup> CA_1A-3A-41C <sup>13,14</sup> CA_1A-3A-41D <sup>13,14</sup>	3			-97	-94	-92.2	-91	FDD	1
	41 <sup>19</sup>			-93.3	-90.7	-89.2	-88.1	TDD	
	41 <sup>19</sup>			-93.3	-90.7	-89.2	-88.1	TDD	
CA_1A-3A-41A-42A <sup>12,14</sup> CA_1A-3A-41A-42C <sup>12,14</sup> CA_1A-3A-41C-42A <sup>12,14</sup> CA_1A-3A-41C-42C <sup>12,14</sup>	3 <sup>19</sup>			-94	-91.5	-90	-89	FDD	1
	41 <sup>19</sup>			-93.3	-90.7	-89.2	-88.1	TDD	
	41 <sup>19</sup>			-93.3	-90.7	-89.2	-88.1	TDD	
CA_1A-3A-41A-42A <sup>13,14</sup> CA_1A-3A-41A-42C <sup>13,14</sup> CA_1A-3A-41C-42A <sup>13,14</sup> CA_1A-3A-41C-42C <sup>13,14</sup>	3			-97	-94	-92.2	-91	FDD	1
	41 <sup>19</sup>			-93.3	-90.7	-89.2	-88.1	TDD	
	41 <sup>19</sup>			-93.3	-90.7	-89.2	-88.1	TDD	
CA_1A-3C-40C	40 <sup>19</sup>			-100	-92.9	-91.3	-90.2	TDD	3
CA_1A-3C-40C	1 <sup>19</sup>			-91.7	[-89.5]	[-87.9]	[-86.9]	FDD	40
	3 <sup>19</sup>			-94.2	-91.2	-89.5	-88.3		
CA_1A-5A-40A	40 <sup>19</sup>				-91.9	-90.4	-89.4	TDD	1
CA_1A-5A-40A	1 <sup>19</sup>			-91.7	[-89.5]	[-87.9]	[-86.9]	FDD	40
CA_1A-7A-8A-40A	40 <sup>19</sup>			-92.6	-90.5	-89.2	-88.1	TDD	1
CA_1A-7A-8A-40A	40 <sup>19</sup>			-96	-93.3	-91.7	-90.6	TDD	7
CA_1A-7A-8A-40A	1 <sup>19</sup>			-91.7	-89.5	-87.9	-86.9	FDD	40
	7 <sup>19</sup>				-94	-92.4	-91.2		
CA_1A-7A-8A-40C	40 <sup>19</sup>			-92.6	-90.5	-89.2	-88.1	TDD	1
CA_1A-7A-8A-40C	40 <sup>19</sup>			-96	-93.3	-91.7	-90.6	TDD	7
CA_1A-7A-8A-40C	1 <sup>19</sup>			-91.7	-89.5	-87.9	-86.9	FDD	40
	7 <sup>19</sup>				-94	-92.4	-91.2		
CA_1A-7A-20A-42A	42 <sup>19</sup>			-95.6	-93	-91.5	-90.4	TDD	7
CA_1A-7A-20A-42A	7 <sup>19</sup>			-96.2	-93.2	-91.5	-90.3	FDD	42
CA_1A-7A-28A-40A CA_1A-7A-28A-40C	1 <sup>19</sup>			-91.7	-89.5	-87.9	-86.9	FDD	40
	7 <sup>19</sup>			-96.8	-94	-92.4	-91.2	FDD	
	28			-96.8	-94.1	-92.5	-89.8	FDD	
CA_1A-7A-28A-40A CA_1A-7A-28A-40C	40 <sup>19</sup>			-92.6	-90.5	-89.2	-88.1	TDD	1
CA_1A-7A-28A-40A CA_1A-7A-28A-40C	40 <sup>19</sup>			-96	-93.3	-91.7	-90.6	TDD	7
CA_1A-7A-28A-40A CA_1A-7A-28A-40C	40 <sup>19</sup>			-95.1	-92.9	-91.4	-90.5	TDD	28
CA_1A-7A-38A	7 <sup>19</sup>			-93.3	-90.7	-89.2	-88.1	FDD	1
	38			-93.3	-90.7	-89.2	-88.1	TDD	
CA_1A-7A-40A	40 <sup>19</sup>			-92.6	-90.5	-89.2	-88.1	TDD	1
CA_1A-7A-40A	40 <sup>19</sup>			-96	-93.3	-91.7	-90.6	TDD	7

CA_1A-7A-40A	1 <sup>19</sup>			-91.7	-89.5	-87.9	-86.9	FDD	40
	7 <sup>19</sup>				-94	-92.4	-91.2		
CA_1A-7A-40C	40 <sup>19</sup>			-92.6	-90.5	-89.2	-88.1	TDD	1
CA_1A-7A-40C	40 <sup>19</sup>			-96	-93.3	-91.7	-90.6	TDD	7
CA_1A-7A-40C	1 <sup>19</sup>			-91.7	-89.5	-87.9	-86.9	FDD	40
	7 <sup>19</sup>				-94	-92.4	-91.2		
CA_1A-7A-42A	42 <sup>19</sup>			-95.6	-93	-91.5	-90.4	TDD	7
	7 <sup>19</sup>			-96.2	-93.2	-91.5	-90.3	FDD	42
CA_1A-8A-40A	40 <sup>19</sup>			[-93.4]	-91.9	-90.4	-89.4	TDD	1
CA_1A-8A-40A	1 <sup>19</sup>			-91.7	[-89.5]	[-87.9]	[-86.9]	FDD	40
CA_1A-8A-40C	40 <sup>19</sup>			[-93.4]	-91.9	-90.4	-89.4	TDD	1
CA_1A-8A-40C	1 <sup>19</sup>			-91.7	[-89.5]	[-87.9]	[-86.9]	FDD	40
CA_1A-28A-40A	1 <sup>19</sup>			-91.7	[-89.5]	[-87.9]	[-86.9]	FDD	40
	28			-96.8	-94.1	-92.5	-89.8		
CA_1A-28A-40A	40 <sup>19</sup>			[-93.4]	-91.9	-90.4	-89.4	TDD	1
CA_1A-28A-40C									
CA_1A-28A-40A	40 <sup>19</sup>			-95.1	-92.9	-91.4	-90.5	TDD	28
CA_1A-28A-40C									
CA_1A-40A	40 <sup>19</sup>			[-93.4]	-91.9	-90.4	-89.4	TDD	1
CA_1A-40A	1 <sup>19</sup>			-91.7	[-89.5]	[-87.9]	[-86.9]	FDD	40
CA_1A-40C	40 <sup>19</sup>			[-93.4]	-91.9	-90.4	-89.4	TDD	1
CA_1A-40C	1 <sup>19</sup>			-91.7	[-89.5]	[-87.9]	[-86.9]	FDD	40
CA_3A-5A-40A	40 <sup>19</sup>				-92.9	-91.3	-90.2	TDD	3
CA_3A-5A-40A	3 <sup>19</sup>		[-95.3]	-94.2	-91.2	-89.5	-88.3	FDD	40
CA_3A-5A-41A <sup>5</sup>	41						[-88.1]	TDD	3
	3			[-94]	[-91]	[-89.2]	[-87.9]	FDD	41
CA_3A-5A-41A <sup>5,18</sup>	41					-91.5	TDD		
CA_3A-7A-8A-38A	7 <sup>19</sup>			[-93.8]	[-91.2]	[-89.7]	[-88.6]	FDD	3
	38			[-93.8]	[-91.2]	[-89.7]	[-88.6]	TDD	
CA_3A-7A-8A-38A	7 <sup>19</sup>			[-93.8]	[-91.2]	[-89.7]	[-88.6]	FDD	8
	38			[-93.8]	[-91.2]	[-89.7]	[-88.6]	TDD	
CA_3C-7A-8A-38A	7 <sup>19</sup>			[-93.8]	[-91.2]	[-89.7]	[-88.6]	FDD	3
	38			[-93.8]	[-91.2]	[-89.7]	[-88.6]	TDD	
CA_3C-7A-8A-38A	7 <sup>19</sup>			[-93.8]	[-91.2]	[-89.7]	[-88.6]		3
CA_3A-7A-8A-40A	40 <sup>19</sup>			-94.6	-92.1	-90.5	-89.4	TDD	3
CA_3A-7A-8A-40A	40 <sup>19</sup>			-96	-93.3	-91.7	-90.6	TDD	7
CA_3A-7A-8A-40C	40 <sup>19</sup>			-94.6	-92.1	-90.5	-89.4	TDD	3
CA_3A-7A-8A-40C	40 <sup>19</sup>			-96	-93.3	-91.7	-90.6	TDD	7
CA_3A-7A-8A-40A	3 <sup>19</sup>			-94.2	-91.2	-89.5	-88.3	FDD	40
	7 <sup>19</sup>				-94	-92.4	-91.2		
CA_3A-7A-8A-40C	3 <sup>19</sup>			-94.2	-91.2	-89.5	-88.3	FDD	40
	7 <sup>19</sup>				-94	-92.4	-91.2		
CA_3A-7A-28A-38A	7 <sup>19</sup>			[-93.8]	[-91.2]	[-89.7]	[-88.6]	FDD	3
	38			[-93.8]	[-91.2]	[-89.7]	[-88.6]	TDD	
CA_3A-7A-28A-38A	7 <sup>19</sup>			[-93.8]	[-91.2]	[-89.7]	[-88.6]	FDD	28
	38			[-93.8]	[-91.2]	[-89.7]	[-88.6]	TDD	
CA_3C-7A-28A-38A	7 <sup>19</sup>			[-93.8]	[-91.2]	[-89.7]	[-88.6]	FDD	3
	38			[-93.8]	[-91.2]	[-89.7]	[-88.6]	TDD	
CA_3C-7A-28A-38A	7 <sup>19</sup>			[-93.8]	[-91.2]	[-89.7]	[-88.6]	FDD	3
	38			[-93.8]	[-91.2]	[-89.7]	[-88.6]	TDD	
CA_3A-7A-28A-40A	3 <sup>19</sup>			-94.2	-91.2	-89.5	-88.3	FDD	40
	7 <sup>19</sup>			-96.8	-94	-92.4	-91.2	FDD	
	28			-96.8	-94.1	-92.5	-89.8	FDD	

CA_3A-7A-28A-40A	40 <sup>19</sup>			-94.6	-92.1	-90.5	-89.4	TDD	3
CA_3A-7A-28A-40C	40 <sup>19</sup>			-96	-93.3	-91.7	-90.6	TDD	7
CA_3A-7A-28A-40A	40 <sup>19</sup>			-95.1	-92.9	-91.4	-90.5	TDD	28
CA_3A-7A-28A-40C	40 <sup>19</sup>			-95.1	-92.9	-91.4	-90.5	TDD	28
CA_3A-7A-38A	7 <sup>19</sup>			[-93.8]	[-91.2]	[-89.7]	[-88.6]	FDD	3
	38			[-93.8]	[-91.2]	[-89.7]	[-88.6]	TDD	
CA_3C-7A-38A	7 <sup>19</sup>			[-93.8]	[-91.2]	[-89.7]	[-88.6]	FDD	3
	38			[-93.8]	[-91.2]	[-89.7]	[-88.6]	TDD	
CA_3A-7A-40A	40 <sup>19</sup>			-94.6	-92.1	-90.5	-89.4	TDD	3
CA_3A-7A-40A	40 <sup>19</sup>			-96	-93.3	-91.7	-90.6	TDD	7
CA_3A-7A-40A	3 <sup>19</sup>			-94.2	-91.2	-89.5	-88.3	FDD	40
	7 <sup>19</sup>			-96.8	-94	-92.4	-91.2		
CA_3A-7A-40C	40 <sup>19</sup>			-94.6	-92.1	-90.5	-89.4	TDD	3
CA_3A-7A-40C	40 <sup>19</sup>			-96	-93.3	-91.7	-90.6	TDD	7
CA_3A-7A-40C	3 <sup>19</sup>			-94.2	-91.2	-89.5	-88.3	FDD	40
	7 <sup>19</sup>			-96.8	-94	-92.4	-91.2		
CA_3A-7A-42A	42 <sup>19</sup>			-95.6	-93	-91.5	-90.4	TDD	7
	3			[-96.6]	[-93.6]	[-91.8]	[-90.6]	FDD	42
	7 <sup>19</sup>			-96.2	-93.2	-91.5	-90.3		
CA_3A-8A-40A	40 <sup>19</sup>			-95.4	-92.9	-91.3	-90.2	TDD	3
CA_3A-8A-40C	40 <sup>19</sup>			-95.4	-92.9	-91.3	-90.2	TDD	3
CA_3A-8A-40C	3 <sup>19</sup>			-94.2	-91.2	-89.5	-88.3	FDD	40
CA_3A-8A-40A	3 <sup>19</sup>			-94.2	-91.2	-89.5	-88.3	FDD	40
CA_3A-20A-32A	32			-99.5	-96.5	-94.7	-93.5	FDD	3
CA_3A-28A-40A	40 <sup>19</sup>			-95.4	-92.9	-91.3	-90.2	TDD	3
CA_3A-28A-40A	3 <sup>19</sup>			-94.2	-91.2	-89.5	-88.3	FDD	40
CA_3A-28A-40A	40 <sup>19</sup>			-95.1	-92.9	-91.4	-90.5	TDD	28
CA_3A-28A-40C	40 <sup>19</sup>			-95.4	-92.9	-91.3	-90.2	TDD	3
CA_3A-28A-40C	40 <sup>19</sup>			-95.1	-92.9	-91.4	-90.5	TDD	28
CA_3A-28A-40C	3 <sup>19</sup>			-94.2	-91.2	-89.5	-88.3	FDD	40
	28			-96.8	-94.1	-92.5	-89.8		
CA_3A-28A-40D	40 <sup>19</sup>				-92.9	-91.3	-90.2	TDD	3
CA_3A-28A-40D	40 <sup>19</sup>				-92.9	-91.4	-90.5	TDD	28
CA_3A-28A-40D	3 <sup>19</sup>			-94.2	-91.2	-89.5	-88.3	FDD	40
	28			-96.8	-94.1	-92.5	-89.8		
CA_3A-28A-41A <sup>5</sup>	41 <sup>19</sup>			[-93.3]	[-90.7]	[-89.2]	[-88.1]	TDD	3
	3 <sup>19</sup>			[-94]	[-91]	[-89.2]	[-87.9]	FDD	41
CA_3A-28A-41C <sup>5</sup>	41 <sup>19</sup>			[-93.3]	[-90.7]	[-89.2]	[-88.1]	TDD	3
	3 <sup>19</sup>			[-94]	[-91]	[-89.2]	[-87.9]	FDD	41
CA_3A-28A-41A-42A	3 <sup>19</sup>			[-94]	[-91]	[-89.2]	[-87.9]	FDD	41
	41				-94.5 <sup>17</sup>	-92.7 <sup>17</sup>	-91.5 <sup>17</sup>	TDD	
CA_3A-28A-41A-42A	41 <sup>19</sup>				[-90.7]	[-89.2]	[-88.1]	TDD	3

CA_3A-28A-41A-42C	41 <sup>19</sup>				[-90.7]	[-89.2]	[-88.1]	TDD	3
	3 <sup>19</sup>			[-94]	[-91]	[-89.2]	[-87.9]	FDD	41
	41				-94.5 <sup>17</sup>	-92.7 <sup>17</sup>	-91.5 <sup>17</sup>	TDD	
CA_3A-28A-41C-42A	41 <sup>19</sup>				[-90.7]	[-89.2]	[-88.1]	TDD	3
	3 <sup>19</sup>			[-94]	[-91]	[-89.2]	[-87.9]	FDD	41
	41				-94.5 <sup>17</sup>	-92.7 <sup>17</sup>	-91.5 <sup>17</sup>	TDD	
CA_3A-40A	40 <sup>19</sup>			-95.4	-92.9	-91.3	-90.2	TDD	3
CA_3A-40A	3 <sup>19</sup>	[-97.4]	[-95.3]	-94.2	-91.2	-89.5	-88.3	FDD	40
CA_3A-40A-40A	40 <sup>19</sup>				-92.9		-90.2	TDD	3
CA_3A-40A-40A	3 <sup>19</sup>			-94.2	-91.2			FDD	40
CA_3A-40C	40 <sup>19</sup>			-95.4	-92.9	-91.3	-90.2	TDD	3
CA_3A-40D	40 <sup>19</sup>			-95.4	-92.9	-91.3	-90.2	TDD	3
CA_3A-40D	3 <sup>19</sup>			-94.2	-91.2	-89.5	-88.3	FDD	40
CA_3A-40E	40 <sup>19</sup>					-91.3	-90.2	TDD	3
CA_3A-40E	3 <sup>19</sup>			-94.2	-91.2	-89.5	-88.3	FDD	40
CA_3A-40C	3 <sup>19</sup>			-94.2	-91.2	-89.5	-88.3	FDD	40
CA_3C-40A	40 <sup>19</sup>			-95.4	-92.9	-91.3	-90.2	TDD	3
CA_3C-40A	3 <sup>19</sup>			-94.2	-91.2	-89.5	-88.3	FDD	40
CA_3C-40C	40 <sup>19</sup>			-95.4	-92.9	-91.3	-90.2	TDD	3
CA_3C-40C	3 <sup>19</sup>			-94.2	-91.2	-89.5	-88.3	FDD	40
CA_3A-41A <sup>5</sup>	3 <sup>19</sup>		[-95.3]	[-94]	[-91]	[-89.2]	[-87.9]	FDD	41
	41 <sup>19</sup>			[-93.3]	[-90.7]	[-89.2]	[-88.1]	TDD	3
CA_3A-41C <sup>5</sup>	3 <sup>19</sup>			[-94]	[-91]	[-89.2]	[-87.9]	FDD	41
	41 <sup>19</sup>			[-93.3]	[-90.7]	[-89.2]	[-88.1]	TDD	3
CA_3A-41D <sup>5</sup>	3 <sup>19</sup>			[-94]	[-91]	[-89.2]	[-87.9]	FDD	41
	41 <sup>19</sup>			[-93.3]	[-90.7]	[-89.2]	[-88.1]	TDD	3
CA_3A-3A-41A	3		[-95.3]	[-94]	[-91]	[-89.2]	[-87.9]	FDD	41
	41			[-93.3]	[-90.7]	[-89.2]	[-88.1]	TDD	3
CA_3C-41A <sup>5</sup>	3 <sup>19</sup>			[-94]	[-91]	[-89.2]	[-87.9]	FDD	41
	41 <sup>19</sup>			[-93.3]	[-90.7]	[-89.2]	[-88.1]	TDD	3
CA_3C-41C <sup>5</sup>	3 <sup>19</sup>			[-94]	[-91]	[-89.2]	[-87.9]	FDD	41
	41 <sup>19</sup>			[-93.3]	[-90.7]	[-89.2]	[-88.1]	TDD	3
CA_3C-41D <sup>5</sup>	3 <sup>19</sup>			[-94]	[-91]	[-89.2]	[-87.9]	FDD	41
	41 <sup>19</sup>			[-93.3]	[-90.7]	[-89.2]	[-88.1]	TDD	3
CA_3A-41A-42A <sup>5,6,7,8</sup>	41 <sup>19</sup>			[-93.3]	[-90.7]	[-89.2]	[-88.1]	TDD	3
	42 <sup>19</sup>			-71.7	-71.7	-71.7	-71.7	TDD	
CA_3A-41A-42A <sup>5,6,9</sup>	41 <sup>19</sup>			[-93.3]	[-90.7]	[-89.2]	[-88.1]	TDD	3
	42 <sup>19</sup>			-97.1	-94.7	-93.2	-92.5	TDD	
CA_3A-41A-42A <sup>5,6,10</sup>	3 <sup>19</sup>			[-93.5]	[-90.5]	[-88.7]	[-87.4]	FDD	41
CA_3A-41A-42C <sup>5,6,7,8</sup>	41 <sup>19</sup>				[-90.7]	[-89.2]	[-88.1]	TDD	3
	42 <sup>19</sup>				-71.7	-71.7	-71.7	TDD	
CA_3A-41A-42C <sup>5,6,9</sup>	41 <sup>19</sup>				[-90.7]	[-89.2]	[-88.1]	TDD	3
	42 <sup>19</sup>				-94.7	-93.2	-92.5	TDD	
CA_3A-41A-42C <sup>5,6,10</sup>	3 <sup>19</sup>			[-93.5]	[-90.5]	[-88.7]	[-87.4]	FDD	41
	42				-95.5	-93.7	-92.5	TDD	
CA_3A-41C-42A <sup>5,6,7,8</sup>	41 <sup>19</sup>				[-90.7]	[-89.2]	[-88.1]	TDD	3
	42 <sup>19</sup>				-71.7	-71.7	-71.7	TDD	
CA_3A-41C-42A <sup>5,6,9</sup>	41 <sup>19</sup>				[-90.7]	[-89.2]	[-88.1]	TDD	3
	42				-94.7	-93.2	-92.5	TDD	
CA_3A-41C-42A <sup>5,6,10</sup>	3 <sup>19</sup>			[-93.5]	[-90.5]	[-88.7]	[-87.4]	FDD	41
CA_3A-41C-42C <sup>5,6,7,8</sup>	41 <sup>19</sup>			[-93.3]	[-90.7]	[-89.2]	[-88.1]	TDD	3
	42 <sup>19</sup>				-71.7	-71.7	-71.7	TDD	
CA_3A-41C-42C <sup>5,6,9</sup>	41 <sup>19</sup>			[-93.3]	[-90.7]	[-89.2]	[-88.1]	TDD	3



	42 <sup>19</sup>			-97.1	-94.7	-93.2	-92.5		
CA_3A-41C-42C <sup>5,6,10</sup>	3 <sup>19</sup>			[-93.5]	[-90.5]	[-88.7]	[-87.4]	FDD	41

CA_7A-8A-38A	7 <sup>19</sup>				[-91.2]	[-89.7]	[-88.6]	FDD	8
	38			[-93.8]	[-91.2]	[-89.7]	[-88.6]	TDD	
CA_7A-8A-40A	40 <sup>19</sup>			-96.3	-93.6	-92	-90.9	TDD	7
	7 <sup>19</sup>			-88	-87.4	-87	-86.7	FDD	8
	7 <sup>19</sup>			-97.1	-94.3	-92.7	-91.5	FDD	40
CA_7A-8A-40C	40 <sup>19</sup>			-96.3	-93.6	-92	-90.9	TDD	7
	7 <sup>19</sup>			-88	-87.4	-87	-86.7	FDD	8
	7 <sup>19</sup>			-97.1	-94.3	-92.7	-91.5	FDD	40
CA_7A-20A-42A	42 <sup>19</sup>			-95.6	-93	-91.5	-90.4	TDD	7
	7 <sup>19</sup>			-96.2	-93.2	-91.5	-90.3	FDD	42
CA_7A-28A-38A	7 <sup>19</sup>				[-91.2]	[-89.7]	[-88.6]	FDD	8
	38			[-93.8]	[-91.2]	[-89.7]	[-88.6]	TDD	
CA_7A-28A-40A	7 <sup>19</sup>			-96.8	-94	-92.4	-91.2	FDD	40
CA_7A-28A-40C	28			-96.8	-94.1	-92.5	-89.8	FDD	
CA_7A-28A-40A CA_7A-28A-40C	40 <sup>19</sup>			-96	-93.3	-91.7	-90.6	TDD	7
CA_7A-28A-40A CA_7A-28A-40C	40 <sup>19</sup>			-95.1	-92.9	-91.4	-90.5	TDD	28
	40 <sup>19</sup>			-96.3	-93.6	-92	-90.9	TDD	7
CA_7A-40A	7 <sup>19</sup>			-97.1	-94.3	-92.7	-91.5	FDD	40
	40 <sup>19</sup>			-96.3	-93.6	-92	-90.9	TDD	7
CA_7A-40C	7 <sup>19</sup>			-97.1	-94.3	-92.7	-91.5	FDD	40
	40 <sup>19</sup>			-96.3	-93.6	-92	-90.9	TDD	7
CA_7A-40D	7 <sup>19</sup>			-97.1	-94.3	-92.7	-91.5	FDD	40
	40 <sup>19</sup>			-96.3	-93.6	-92	-90.9	TDD	7
CA_7A-40E	7 <sup>19</sup>			-97.1	-94.3	-92.7	-91.5	FDD	40
	42 <sup>19</sup>			-95.6	-93	-91.5	-90.4	TDD	7
CA_7A-42A	7 <sup>19</sup>			-96.2	-93.2	-91.5	-90.3	FDD	42
	42 <sup>19</sup>			-95.6	-93	-91.5	-90.4	TDD	7
CA_7A-42A-42A	7 <sup>19</sup>			-96.2	-93.2	-91.5	-90.3	FDD	42
	25			[-95.9]	[-92.9]	[-91.1]	[-89.9]	FDD	41
CA_25A-41A, CA_25A-25A-41A, CA_25A-41C, CA_25A-25A-41C, CA_25A-41D, CA_25A-25A-41D, CA_25A-41E, CA_25A-25A-41E, CA_25A-41F, CA_25A-25A-41F	40			-95.1	-92.9	-91.4	-90.5	TDD	28
CA_28A-40A	28			-96.8	-94.1	-92.5	-89.8	FDD	40
CA_28A-40C	40			-95.1	-92.9	-91.4	-90.5	TDD	28
CA_28A-40C	28			-96.8	-94.1	-92.5	-89.8	FDD	40
CA_28A-40D	40			-95.1	-92.9	-91.4	-90.5	TDD	28
CA_28A-40D	28			-96.8	-94.1	-92.5	-89.8	FDD	40

- NOTE 1: The transmitter shall be set to  $P_{UMAX}$  as defined in subclause 6.2.5A
- NOTE 2: Reference measurement channel is A.3.2 with one sided dynamic OCNG Pattern OP.1 FDD/TDD as described in Annex A.5.1.1/A.5.2.1
- NOTE 3: The signal power is specified per port
- NOTE 4: These requirements apply regardless of the channel bandwidth and the location of UL band.
- NOTE 5: The B41 requirements are modified by -0.5dB when carrier frequency of the assigned E-UTRA channel bandwidth is within 2545-2690 MHz.
- NOTE 6: The antenna isolation for MSD calculation is assumed as 10 dB. For conducted mode REFSENS test such antenna isolation is not observed as the antennas are disconnected. Additionally antenna isolation assumption is under discussion depending on the frequency range
- NOTE 7: These requirements apply when there is at least one individual RE within the uplink transmission bandwidth of the aggressor (lower) band for which the 2nd transmitter harmonic is within the downlink transmission bandwidth of a victim (higher) band and a range  $\Delta F_{HD}$  above and below the edge of this downlink transmission bandwidth. The value  $\Delta F_{HD}$  depends on the E-UTRA configuration:  $\Delta F_{HD} = 10$  MHz for CA\_3A-42A, CA\_3A-42C, CA\_3A-42D, CA\_3A-3A-42C, CA\_3A-42A-42C, CA\_1A-3A-42A, CA\_1A-3A-42C, CA\_1A-3A-42D, CA\_3A-19A-42A, CA\_3A-19A-42C, CA\_1A-3A-19A-42A, CA\_3A-41A-42C, CA\_3A-41C-42A, and CA\_3A-41C-42C.
- NOTE 8: The requirements should be verified for UL EARFCN of the aggressor (lower) band (superscript LB) such that  $f_{UL}^{LB} = f_{DL}^{HB} / 0.2 \text{ b}_1$  in MHz and  $F_{UL\_low}^{LB} + BW_{Channel}^{LB} / 2 \leq f_{UL}^{LB} \leq F_{UL\_high}^{LB} - BW_{Channel}^{LB} / 2$  with  $f_{DL}^{HB}$  carrier frequency in the victim (higher) band in MHz and  $BW_{Channel}^{LB}$  the channel bandwidth configured in the lower band.
- NOTE 9: The requirements are only applicable to channel bandwidths with a carrier frequency at  $\pm (20 + BW_{Channel}^{HB} / 2)$  MHz offset from  $2f_{UL}^{LB}$  in the victim (higher band) with  $F_{UL\_low}^{LB} + BW_{Channel}^{LB} / 2 \leq f_{UL}^{LB} \leq F_{UL\_high}^{LB} - BW_{Channel}^{LB} / 2$ , where  $BW_{Channel}^{LB}$  and  $BW_{Channel}^{HB}$  are the channel bandwidths configured in the aggressor (lower) and victim (higher) bands in MHz, respectively.
- NOTE 10: Only applicable for UE supporting inter-band carrier aggregation with uplink in one E-UTRA band and without simultaneous Rx/Tx.
- NOTE 11: Void
- NOTE 12: These requirements apply when the uplink is active in Band 1 and the separation between the lower edge of the uplink channel in Band 1 and the upper edge of the downlink channel in Band 3 is < 60 MHz. For each channel bandwidth in Band 3 and Band 41, the requirement applies regardless of channel bandwidth in Band 1.
- NOTE 13: These requirements apply when the uplink is active in Band 1 and the separation between the lower edge of the uplink channel in Band 1 and the upper edge of the downlink channel in Band 3 is  $\geq 60$  MHz. For each channel bandwidth in Band 3 and Band 41, the requirement applies regardless of channel bandwidth in Band 1.
- NOTE 14: The B41 requirements also apply to the supported CA\_1A-41A.
- NOTE 15: These requirements apply when the uplink is active in Band 1 and the separation between the lower edge of the uplink channel in Band 1 and the upper edge of the downlink channel in Band 3 is < 60 MHz. For each channel bandwidth other than Band 1, the requirement applies regardless of channel bandwidth in Band 1
- NOTE 16: These requirements apply when the uplink is active in Band 1 and the separation between the lower edge of the uplink channel in Band 1 and the upper edge of the downlink channel in Band 3 is  $\geq 60$  MHz. For each channel bandwidth other than Band 1, the requirement applies regardless of channel bandwidth in Band 1.
- NOTE 17: The B41 requirements are modified by -0.1dB when carrier frequency of the assigned E-UTRA channel bandwidth is within 2545-2690 MHz.
- NOTE 18: No requirements apply when there is at least one individual RE within the downlink transmission bandwidth of band5 for which the 3rd receiver harmonic is within the uplink transmission bandwidth of band41. The reference sensitivity is only verified when this is not the case (the requirements specified in clause 7.3.1 apply).
- NOTE 19: Applicable for the operations with 2 or 4 antenna ports supported in the band with carrier aggregation configured.

**Table 7.3.1A-0bF: Uplink configuration for reference sensitivity (exceptions due to cross band isolation issues of TDD and FDD bands)**

E-UTRA Band / Channel bandwidth of the affected DL band / $N_{RB}$ / Duplex mode								
EUTRA CA Configuration	E-UTRA Band	1.4 MHz	3 MHz	5 MHz	10 MHz	15 MHz	20 MHz	Duplex Mode
CA_1A-3A-5A-41A	3			25	50	50 <sup>1</sup>	50 <sup>1</sup>	FDD
CA_1A-3A-7A-20A-42A	7			25	50	75	75 <sup>1</sup>	FDD
	42			25	50	75	100	FDD
CA_1A-3A-7A-38A	1			25	50	75	100	FDD
CA_1A-3C-7A-38A	3			25	50	50 <sup>1</sup>	50 <sup>1</sup>	FDD
	11, <sup>3</sup>			25	25	25	25	FDD
CA_1A-3A-7A-40A	11, <sup>4</sup>			25	45	45	45	FDD
	3			25	50	50 <sup>1</sup>	50 <sup>1</sup>	FDD
CA_1A-3A-7A-40C	7			25	50	75	75 <sup>1</sup>	FDD
	40			25	50	75	100	TDD
CA_1A-3A-7A-42A	7			25	50	75	75 <sup>1</sup>	FDD
	42			25	50	75	100	TDD
CA_1A-3A-28A-40A	1			25	50	75	100	FDD
	3			25	50	50 <sup>1</sup>	50 <sup>1</sup>	FDD
CA_1A-3A-28A-40C	28			25	25 <sup>1</sup>	25 <sup>1</sup>	25 <sup>1</sup>	FDD
	40			25	50	75	100	TDD
CA_1A-3A-38A CA_1A-3C-38A	11, <sup>3</sup>			25	25	25	25	FDD
	11, <sup>4</sup>			25	45	45	45	FDD
	3			25	50	50 <sup>1</sup>	50 <sup>1</sup>	FDD
CA_1A-3A-41A CA_1A-3A-41C CA_1A-3A-41D	38			25	50	75	100	TDD
	1			25 <sup>3</sup>	25 <sup>1,3</sup>	25 <sup>1,3</sup>	25 <sup>1,3</sup>	FDD
CA_1A-3A-41C CA_1A-3A-41D	3			25 <sup>4</sup>	45 <sup>1,4</sup>	45 <sup>1,4</sup>	45 <sup>1,4</sup>	FDD
	3			25	50	50 <sup>1</sup>	50 <sup>1</sup>	FDD
	1			25 <sup>3</sup>	25 <sup>1,3</sup>	25 <sup>1,3</sup>	25 <sup>1,3</sup>	FDD

CA_1A-3A-41A-42A				25 <sup>4</sup>	45 <sup>1,4</sup>	45 <sup>1,4</sup>	45 <sup>1,4</sup>	FDD
CA_1A-3A-41A-42C								
CA_1A-3A-41C-42A	3			25	50	50 <sup>1</sup>	50 <sup>1</sup>	FDD
CA_1A-3A-41C-42C								
CA_1A-5A-40A	1			25	50	75	100	FDD
	40			25	50	75	100	TDD
CA_1A-7A-8A-40A	1			25	50	75	100	FDD
	7			25	50	75	75 <sup>1</sup>	FDD
	40			25	50	75	100	TDD
CA_1A-7A-8A-40C	1			25	50	75	100	FDD
	7			25	50	75	75 <sup>1</sup>	FDD
	40			25	50	75	100	TDD
CA_1A-7A-28A-40A	1			25	50	75	100	FDD
	7			25	50	75	75 <sup>1</sup>	FDD
CA_1A-7A-28A-40C	28			25	25 <sup>1</sup>	25 <sup>1</sup>	25 <sup>1</sup>	FDD
	40			25	50	75	100	TDD
CA_1A-8A-40A	1			25	50	75	100	FDD
	40			25	50	75	100	TDD
CA_1A-8A-40C	1			25	50	75	100	FDD
	40			25	50	75	100	TDD
CA_1A-7A-20A-42A	1			25	50	75	100	FDD
	7			25	50	75	75 <sup>1</sup>	FDD
	20			25	20 <sup>1</sup>	20 <sup>5</sup>	20 <sup>5</sup>	FDD
	42			25	50	75	100	TDD
CA_1A-7A-38A	1			25	45	45 <sup>1</sup>	45 <sup>1</sup>	FDD
CA_1A-7A-40A	1			25	50	75	100	FDD
	7			25	50	75	75 <sup>1</sup>	FDD
	40			25	50	75	100	TDD
CA_1A-7A-40C	1			25	50	75	100	FDD
	7			25	50	75	75 <sup>1</sup>	FDD
	40			25	50	75	100	TDD
CA_1A-7A-42A	1			25	50	75	100	FDD
	7			25	50	75	75 <sup>1</sup>	FDD
	42			25	50	75	100	TDD
CA_1A-40A	1			25	50	75	100	FDD
	40			25	50	75	100	TDD
CA_1A-28A-40A CA_1A-28A-40C	1			25	50	75	100	FDD
	28			25	25 <sup>1</sup>	25 <sup>1</sup>	25 <sup>1</sup>	FDD
	40			25	50	75	100	TDD
CA_3A-5A-41A	3			25	50	50 <sup>1</sup>	50 <sup>1</sup>	FDD
	41						100	TDD
CA_3A-7A-8A-38A	3			25	50	50 <sup>1</sup>	50 <sup>1</sup>	FDD
CA_3C-7A-8A-38A	3			25	50	50 <sup>1</sup>	50 <sup>1</sup>	FDD
CA_3A-7A-8A-40A	3			25	50	50 <sup>1</sup>	50 <sup>1</sup>	FDD
	7			25	50	75	75 <sup>1</sup>	FDD
	40			25	50	75	100	TDD
CA_3A-7A-8A-40C	3			25	50	50 <sup>1</sup>	50 <sup>1</sup>	FDD
	7			25	50	75	75 <sup>1</sup>	FDD
	40			25	50	75	100	TDD

CA_3A-7A-28A-38A	3			25	50	50 <sup>1</sup>	50 <sup>1</sup>	FDD
CA_3C-7A-28A-38A	3			25	50	50 <sup>1</sup>	50 <sup>1</sup>	FDD
CA_3A-7A-28A-40A	3			25	50	50 <sup>1</sup>	50 <sup>1</sup>	FDD
	7			25	50	75	75 <sup>1</sup>	FDD
CA_3A-7A-28A-40C	28			25	25 <sup>1</sup>	25 <sup>1</sup>	25 <sup>1</sup>	FDD
	40			25	50	75	100	TDD
CA_3A-7A-38A	3			25	50	50 <sup>1</sup>	50 <sup>1</sup>	FDD
CA_3C-7A-38A	3			25	50	50 <sup>1</sup>	50 <sup>1</sup>	FDD
CA_3A-7A-40A	3			25	50	50 <sup>1</sup>	50 <sup>1</sup>	FDD
	7			25	50	75	75 <sup>1</sup>	FDD
	40			25	50	75	100	TDD
CA_3A-7A-40C	3			25	50	50 <sup>1</sup>	50 <sup>1</sup>	FDD
	7			25	50	75	75 <sup>1</sup>	FDD
	40			25	50	75	100	TDD
CA_3A-7A-42A	7			25	50	75	75 <sup>1</sup>	FDD
	42			25	50	75	100	TDD
CA_3A-8A-40A	3	6	15	25	50	50 <sup>1</sup>	50 <sup>1</sup>	FDD
	40			25	50	75	100	TDD
CA_3A-8A-40C	3	6	15	25	50	50 <sup>1</sup>	50 <sup>1</sup>	FDD
	40			25	50	75	100	TDD
CA_3A-28A-41A	3			25	50	50 <sup>1</sup>	50 <sup>1</sup>	FDD
	28			25	25 <sup>1</sup>	25 <sup>1</sup>	25 <sup>1</sup>	FDD
	41			25	50	75	100	TDD
CA_3A-28A-41C	3			25	50	50 <sup>1</sup>	50 <sup>1</sup>	FDD
	28			25	25 <sup>1</sup>	25 <sup>1</sup>	25 <sup>1</sup>	FDD
	41			25	50	75	100	TDD
CA_3A-28A-41A-42A	3			25	50	50 <sup>1</sup>	50 <sup>1</sup>	FDD
	28			25	25 <sup>1</sup>			FDD
	41				50	75	100	TDD
	42				50	75	100	TDD

CA_3A-28A-41A-42C	3			25	50	50 <sup>1</sup>	50 <sup>1</sup>	FDD
	41				50	75	100	TDD
CA_3A-28A-41C-42A	3			25	50	50 <sup>1</sup>	50 <sup>1</sup>	FDD
	41				50	75	100	TDD
CA_3A-40A CA_3A-40C CA_3A-40D CA_3A-40E CA_1A-3A-40A CA_1A-3C-40A CA_1A-3A-40C CA_1A-3C-40C CA_3A-5A-40A CA_3A-28A-40A CA_3A-28A-40C CA_1A-3A-5A-40A CA_1A-3A-8A-40A	3	6	15	25	50	50 <sup>1</sup>	50 <sup>1</sup>	FDD
	40			25	50	75	100	TDD
CA_3A-40A-40A	3			25	50			FDD
	40				50		100	TDD
CA_3A-41A CA_3A-3A-41A	3		15	25	50	50 <sup>1</sup>	50 <sup>1</sup>	FDD
	41			25	50	75	100	TDD
CA_3A-41C CA_3C-41A CA_3C-41D	3			25	50	50 <sup>1</sup>	50 <sup>1</sup>	FDD
	41			25	50	75	100	TDD
CA_3A-41D	3			25	50	50 <sup>1</sup>	50 <sup>1</sup>	FDD
	41			25	50	75	100	TDD
CA_3C-41C	3			25	50	50 <sup>1</sup>	50 <sup>1</sup>	FDD
	41			25	50	75	100	TDD
CA_3A-41A-42A	3			25	50	50 <sup>1</sup>	50 <sup>1</sup>	FDD
	41			25	50	75	100	TDD
CA_7A-8A-38A	8			25	50			FDD
CA_7A-8A-40A	7			25	50	75	75 <sup>1</sup>	FDD
	8			8	16			
	40			25	50	75	100	TDD
CA_7A-8A-40C	7			25	50	75	75 <sup>1</sup>	FDD
	8			8	16			
	40			25	50	75	100	TDD
CA_7A-20A-42A	7			25	50	75	75 <sup>1</sup>	FDD
	20			25	50	75	100	TDD
CA_7A-28A-38A	42			25	50	75	100	TDD
	28			25	50	50 <sup>1</sup>	50 <sup>1</sup>	FDD
CA_7A-28A-40A CA_7A-28A-40C	7			25	50	75	75 <sup>1</sup>	FDD
	28			25	25 <sup>1</sup>	25 <sup>1</sup>	25 <sup>1</sup>	FDD
	40			25	50	75	100	TDD
CA_7A-40A, CA_7A-40C, CA_7A-40D, CA_7A-40E	7			25	50	75	75 <sup>1</sup>	FDD
	40			25	50	75	100	TDD
CA_7A-42A, CA_7A-42A-42A	7			25	50	75	75 <sup>1</sup>	FDD
	42			25	50	75	100	TDD
	25			25	50	75	100	FDD

CA_25A-41A, CA_25A-41C, CA_25A-41D, CA_25A-41E, CA_25A-41F, CA_25A-25A- 41A, CA_25A-25A- 41C, CA_25A-25A- 41D, CA_25A-25A- 41E, CA_25A-25A- 41F	41			25	50	75	100	TDD
CA_28A-40A, CA_28A-40C	28 40			25	25 <sup>1</sup> 50	25 <sup>1</sup> 75	25 <sup>1</sup> 100	FDD TDD
<p>NOTE 1: <sup>1</sup> refers to the UL resource blocks shall be located as close as possible to the downlink operating band but confined within the transmission bandwidth configuration for the channel bandwidth (Table 5.6-1).</p> <p>NOTE 2: the UL configuration applies regardless of the channel bandwidth of the low band unless the UL resource blocks exceed that specified in Table 7.3.1-2 for the uplink bandwidth in which case the allocation according to Table 7.3.1-2 applies.</p> <p>NOTE 3: UL allocation when the separation between the lower edge of the uplink channel in Band 1 and the upper edge of the downlink channel in Band 3 is &lt; 60 MHz.</p> <p>NOTE 4: UL allocation when the separation between the lower edge of the uplink channel in Band 1 and the upper edge of the downlink channel in Band 3 is ≥ 60 MHz.</p> <p>NOTE 5: <sup>5</sup> refers to Band 20; in the case of 15MHz channel bandwidth, the UL resource blocks shall be located at RB<sub>start</sub> 11 and in the case of 20MHz channel bandwidth, the UL resource blocks shall be located at RB<sub>start</sub> 16</p>								

For band combinations including operating bands without uplink band (as noted in Table 5.5-1), the requirements are specified in Table 7.3.1A-0d and for any uplink band with uplink configuration specified in Table 7.3.1-2.



Table 7.3.1A-0d: Reference sensitivity QPSK  $P_{\text{REFSENS}}$  (CA with a SDL band)

EUTRA CA Configuration	Channel bandwidth							Duplex mode
	EUTRA band	1.4 MHz (dBm)	3 MHz (dBm)	5 MHz (dBm)	10 MHz (dBm)	15 MHz (dBm)	20 MHz (dBm)	
CA_1A-3A-7A-20A-32A	1			-100	-97	-95.2	-94	FDD
	3 <sup>5,6</sup>			-94	-91	-90	-89	
	3 <sup>7</sup>			-97	-94	-92.2	-91	
	7				-95	-93.2	-92	
	20			-97	-94	-91.2	-90	
CA_1A-3A-20A-32A <sup>6</sup>	1			-100	-97	-95.2	-94	FDD
	3			-94	-91.5	-90	-89	
	20			-97	-94	-91.2	-90	
	32			-100	-97	-95.2	-94	
CA_1A-3A-20A-32A-42A	1			-100	-97	-95.2		FDD
	3			-97	-94	-92.2		FDD
	20			-97				FDD
	32			-99.5	-96.5	-94.7	-93.5	FDD
	42			-98.5	-95.5	-93.7	-92.5	TDD
CA_1A-3A-20A-32A-43A	1			-100	-97	-95.2		FDD
	3			-97	-94	-92.2		FDD
	20			-97				FDD
	32			-99.5	-96.5	-94.7	-93.5	FDD
	43			-98.5	-95.5	-93.7	-92.5	TDD
CA_1A-3A-20A-32A <sup>7</sup>	1			-100	-97	-95.2	-94	FDD
	3			-97	-94	-92.2	-91	
	20			-97	-94	-91.2	-90	
	32			-100	-97	-95.2	-94	
CA_1A-3A-32A <sup>6</sup>	1			-100	-97	-95.2	-94	FDD
	3			-94	-91.5	-90	-89	
	32			-100	-97	-95.2	-94	
CA_1A-3A-32A <sup>7</sup>	1			-100	-97	-95.2	-94	FDD
	3			-97	-94	-92.2	-91	
	32			-100	-97	-95.2	-94	
CA_1A-3A-7A-32A <sup>6</sup>	1			-100	-97	-95.2	-94	FDD
	3			-94	-91.5	-90	-89	
	7			-98	-95	-93.2	-92	
	32			-100	-97	-95.2	-94	
CA_1A-3A-7A-32A <sup>7</sup>	1			-100	-97	-95.2	-94	FDD
	3			-97	-94	-92.2	-91	
	7			-98	-95	-93.2	-92	
	32			-100	-97	-95.2	-94	
CA_1A-3A-32A-42A <sup>7</sup>	1			-99.8	-96.8	-95		FDD
	3			-96.8	-93.8	-92		
	32			-99.5	-96.5	-94.7	-93.5	
	42			-98.5	-95.5	-93.7	-92.5	
CA_1A-3A-32A-43A <sup>7</sup>	1			-100	-97	-95.2		FDD
	3			-97	-94	-92.2		
	32			-99.5	-96.5	-94.7	-93.5	
	43			-98.5	-95.5	-93.7	-92.5	

CA_1A-3A-32A-42A-43A	1			-99.8	-96.8	-95		FDD
	3			-96.8	-93.8	-92		FDD
	32			-99.5	-96.5	-94.7	-93.5	FDD
	42			-98.5	-95.5	-93.7	-92.5	TDD
CA_1A-20A-32A-42A	43			-98.5	-95.5	-93.7	-92.5	TDD
	1			-100	-97	-95.2		FDD
	20			-97				
	32			-100	-97	-95.2	-94	TDD
CA_1A-20A-32A-43A	42			-98.5	-95.5	-93.7	-92.5	FDD
	1			-100	-97	-95.2		
	20			-97				
	32			-100	-97	-95.2	-94	TDD
CA_1A-32A	43			-98.5	-95.5	-93.7	-92.5	FDD
	1			-100	-97	-95.2	-94	
CA_1A-32A-42A	32			-100	-97	-95.2	-94	FDD
	1			-100	-97	-95.2		FDD
	42			-98.5	-95.5	-93.7	-92.5	TDD
CA_1A-32A-43A	1			-100	-97	-95.2		FDD
	32			-100	-97	-95.2	-94	FDD
	43			-98.5	-95.5	-93.7	-92.5	TDD
CA_1A-32A-42A-43A	1			-100	-97	-95.2		FDD
	32			-100	-97	-95.2	-94	
	42			-98.5	-95.5	-93.7	-92.5	TDD
	43			-98.5	-95.5	-93.7	-92.5	
CA_2A-4A-5A-29A	1			-100	-97	-95.2		FDD
	32			-100	-97	-95.2	-94	
	42			-98.5	-95.5	-93.7	-92.5	TDD
	43			-98.5	-95.5	-93.7	-92.5	
CA_2A-4A-29A	2			-97.7	-94.7	-92.9	-91.7	FDD
	4			-99.7	-96.7	-94.9	-93.7	
	5			-98	-95			FDD
	29			-97	-94			
CA_2A-4A-29A-30A	2			-97.7	-94.7	-92.9	-91.7	FDD
	4			-99.7	-96.7	-94.9	-93.7	
	29			-97	-94			FDD
	30			-98.5	-95.5			
	2			-98	-95	-93.2	-92	
CA_2A-5A-29A	5			-98	-95			FDD
	29			-97	-94			
	2			-98	-95	-93.2	-92	FDD
7				-95	-93.2	-92		
CA_2A-7A-29A-7A-29A	29			-97	-94			FDD
	2			-98	-95	-93.2	-92	
	7			-98	-95	-93.2	-92	FDD
29			-97	-94				
CA_2A-7A-29A-66A-66A	2			-97.7	-94.7	-92.9	-91.7	FDD
	7				-94.5	-92.7	-91.5	
	29			-97	-94			FDD
	66			-99	-96	-94.2	-93	
CA_2A-29A	2			-98	-95	-93.2	-92	FDD
	29		-98.7	-97	-94			
CA_2A-2A-29A	2			-98	-95	-93.2	-92	FDD
	29			-97	-94			

CA_2C-29A	2			-98	-95	-93.2	-92	FDD
	29			-97	-94			
CA_2A-29A-30A	2			-97.6	-94.6	-92.8	-91.6	FDD
	29			-97	-94			
	30			-98.5	-95.5			
CA_2A-2A-29A-30A	2			-97.6	-94.6	-92.8	-91.6	FDD
	29			-97	-94			
	30			-98.5	-95.5			
CA_2C-29A-30A	2			-97.6	-94.6	-92.8	-91.6	FDD
	29			-97	-94			
	30			-98.5	-95.5			
CA_2A-29A-30A-66A	2			-97.6	-94.6	-92.8	-91.6	FDD
	29			-97	-94			
	30			-98.5	-95.5			
	66			-99.1	-96.1	-94.3	-93.1	
CA_2A-29A-66A	2			-97.7	-94.7	-92.9	-91.7	FDD
	29			-97	-94			
	66			-99.2	-96.2	-94.4	-93.2	
CA_4A-4A-29A	4			-100	-97	-95.2	-94	FDD
	29			-97	-94			
CA_3A-7A-20A-32A	3			-97	-94	-92.2	-91	FDD
	7			-98	-95	-93.2	-92	
	20			-97	-94	-91.2	-90	
	32			-99.5	-96.5	-94.7	-93.5	
CA_3A-7A-32A	3			-97	-94	-92.2	-91	FDD
	7			-98	-95	-93.2	-92	
	32			-100	-97	-95.2	-94	
CA_3A-20A-32A-42A	3			-96.8	-93.8	-92		FDD
	20			-97				
	32			-99.5	-96.5	-94.7	-93.5	
	42			-98.5	-95.5	-93.7	-92.5	
CA_3A-20A-32A-43A	3			-97	-94	-92.2		FDD
	20			-97				
	32			-99.5	-96.5	-94.7	-93.5	
CA_3A-32A	3			-97	-94	-92.2	-91	FDD
	32			-99.5	-96.5	-94.7	-93.5	
	3 <sup>5</sup>			-97	-94	-92.2	-91	
CA_3C-32A	32			-99.5	-96.5	-94.7	-93.5	FDD
	3			-96.8	-93.8	-92		
CA_3A-32A-42A	3			-96.8	-93.8	-92		FDD
	32			-99.5	-96.5	-94.7	-93.5	FDD
	42			-98.5	-95.5	-93.7	-92.5	TDD
CA_3A-32A-43A	3			-97	-94	-92.2		FDD
	32			-99.5	-96.5	-94.7	-93.5	FDD
CA_3A-32A-42A-43A	3			-96.8	-93.8	-92		FDD
	32			-99.5	-96.5	-94.7	-93.5	FDD
CA_3A-32A-42A-43A	42			-98.5	-95.5	-93.7	-92.5	TDD
	43			-98.5	-95.5	-93.7	-92.5	TDD

CA_3A-69A	3			-97	-94	-92.2	-91	FDD
	69			-100	-97	-95.2	-94	
CA_4A-4A-29A-30A	4			-99.6	-96.6	-94.8	-93.6	FDD
	29			-97	-94			
	30			-98.5	-95.5			
CA_4A-5A-29A	4			-100	-97	-95.2	-94	FDD
	5			-98	-95			
	29			-97	-94			
CA_4A-29A	4			-100	-97	-95.2	-94	FDD
	29		-98.7	-97	-94			
CA_4A-29A-30A	4			-99.6	-96.6	-94.8	-93.6	FDD
	29			-97	-94			
	30			-98.5	-95.5			
CA_5A-29A	5			-98	-95			FDD
	29			-97	-94			
CA_7A-20A-32A	7			-98	-95	-93.2	-92	FDD
	20			-97	-94	-91.2	-90	
	32			-100	-97	-95.2	-94	
CA_7A-29A CA_7A-7A-29A CA_7C-29A	7			-98	-95	-93.2	-92	FDD
	29			-97	-94			
CA_7A-29A-66A	7			-98	-95	-93.2	-92	FDD
	29			-97	-94			
	66			-99.5	-96.5	-94.7	-93.5	
CA_7A-7A-29A-66A	7			-98	-95	-93.2	-92	FDD
	29			-97	-94			
	66			-99.5	-96.5	-94.7	-93.5	
CA_7C-29A-66A	7			-98	-95	-93.2	-92	FDD
	29			-97	-94			
	66			-99.5	-96.5	-94.7	-93.5	
CA_7A-32A	7				-95	-93.2	-92	FDD
	32			-100	-97	-95.2	-94	
CA_20A-32A	20			-97	-94	-91.2	-90	FDD
	32			-100	-97	-95.2	-94	
CA_20A-32A-42A	20			-97				FDD
	32			-100	-97	-95.2	-94	FDD
	42			-98.5	-95.5	-93.7	-92.5	TDD
CA_20A-32A-43A	20			-97				FDD
	32			-100	-97	-95.2	-94	FDD
	43			-98.5	-95.5	-93.7	-92.5	TDD
CA_20A-75A	20			-97	-94	-91.2	-90	FDD
	75			-100	-97	-95.2	-94	
CA_20A-76A	20			-97	-94	-91.2	-90	FDD
	76			-100				
CA_20A-67A	20			-97	-94	-91.2	-90	FDD
	67			-100	-97	-95.2	-94	
CA_23A-29A	23			-100	-97	-95.2	-94	FDD
	29		-98.7	-97	-94			
CA_29A-30A	29			-97	-94			FDD
	30			-99	-96			
CA_29A-30A-66A CA_29A-30A-66A- 66A	29			-97	-94			FDD
	30			-98.5	-95.5			
	66			-99.1	-96.1	-94.3	-93.1	

CA_29A-66A	29			-97	-94			FDD
	66			-99.5	-96.5	-94.7	-93.5	
CA_29A-66C	29			-97	-94			FDD
	66			-99.5	-96.5	-94.7	-93.5	
CA_29A-66A-66A	29			-97	-94			FDD
	66			-99.5	-96.5	-94.7	-93.5	
CA_29A-66A-70A	29			-97	-94			FDD
	66			-99.5	-96.5	-94.7	-93.5	
	70			-100	-97	-95.2		
CA_29A-66A-70C	29			-97	-94			FDD
	66			-99.5	-96.5	-94.7	-93.5	
	70			-100	-97	-95.2	-94	
CA_29A-66C-70A	29			-97	-94			FDD
	66			-99.5	-96.5	-94.7	-93.5	
	70			-100	-97	-95.2		
CA_29A-66A-66A-70A	29			-97	-94			FDD
	66			-99.5	-96.5	-94.7	-93.5	
	70			-100	-97	-95.2		
CA_29A-66C-70C	29			-97	-94			FDD
	66			-99.5	-96.5	-94.7	-93.5	
	70			-100	-97	-95.2	-94	
CA_29A-66A-66A-70C	29			-97	-94			FDD
	66			-99.5	-96.5	-94.7	-93.5	
	70			-100	-97	-95.2	-94	
CA_29A-70A	29			-97	-94			FDD
	70			-100	-97	-95.2	-94	
CA_29A-70C	29			-97	-94			FDD
	70			-100	-97	-95.2	-94	
CA_32A-42A	32			-100	-97	-95.2	-94	FDD
	42			-98.5	-95.5	-93.7	-92.5	TDD
CA_32A-43A	32			-100	-97	-95.2	-94	FDD
	43			-98.5	-95.5	-93.7	-92.5	TDD
CA_32A-42A-43A	32			-100	-97	-95.2	-94	FDD
	42			-98.5	-95.5	-93.7	-92.5	TDD
	43			-98.5	-95.5	-93.7	-92.5	TDD

NOTE 1: The transmitter shall be set to  $P_{UMAX}$  as defined in subclause 6.2.5A.  
NOTE 2: Reference measurement channel is A.3.2 with one sided dynamic OCNG Pattern OP.1 FDD/TDD as described in Annex A.5.1.1/A.5.2.1  
NOTE 3: The signal power is specified per port.  
NOTE 4: Void  
NOTE 5: Applicable only if operation with 4 antenna ports is supported in the band with carrier aggregation configured.  
NOTE 6: These requirements apply when the uplink is active in Band 1 and the separation between the lower edge of the uplink channel in Band 1 and the upper edge of the downlink channel in Band 3 is < 60 MHz. For each channel bandwidth in Band 3, the requirement applies regardless of channel bandwidth in Band 1.  
NOTE 7: These requirements apply when the uplink is active in Band 1 and the separation between the lower edge of the uplink channel in Band 1 and the upper edge of the downlink channel in Band 3 is  $\geq$  60 MHz. For each channel bandwidth in Band 3, the requirement applies regardless of channel bandwidth in Band 1.

Table 7.3.1A-0e: Void

For band combinations including operating band 46 (Table 5.5-1), the requirements are specified in Table 7.3.1A-0eA for the uplink in any band other than band 46 with the uplink configuration specified in Table 7.3.1-2 and Table 7.3.1A-0eC.

For band combinations including operating band 49 (Table 5.5-1), the requirements are specified in Table 7.3.1A-0eA for the uplink in any band other than Band 49 with uplink configurations specified in Table 7.3.1-2 and measurement exclusion region in Table 7.3.1A-0eD.

**Table 7.3.1A-0eA: Reference sensitivity QPSK  $P_{\text{REFSENS}}$  (CA with band 46 or Band 49)**

Channel bandwidth								
EUTRA CA Configuration	EUTRA band	1.4 MHz (dBm)	3 MHz (dBm)	5 MHz (dBm)	10 MHz (dBm)	15 MHz (dBm)	20 MHz (dBm)	Duplex mode
CA_1A-3A-7A-46A	1			-100	-97	-95.2	-94	FDD
CA_1A-3A-7A-46C	3			-97	-94	-92.2	-91	
CA_1A-3A-7A-46D	7			-98	-95	-93.2	-92	
CA_1A-3A-7A-46E	46						-90	TDD
CA_1A-3A-46A	1			-100	-97	-95.2	-94	FDD
CA_1A-3A-46C	3			-97	-94	-92.2	-91	
CA_1A-3A-46D	46				-93		-90	TDD
CA_1A-3A-46E	46							
CA_1A-5A-7A-46A	1			-100	-97	-95.2	-94	FDD
CA_1A-5A-7A-46C	5			-98	-95			
CA_1A-5A-7A-46D	7				-95	-93.2	-92	
CA_1A-5A-46A	46						-90	TDD
CA_1A-5A-46C	1			-100	-97	-95.2	-94	FDD
CA_1A-5A-46D	5			-98	-95			FDD
CA_1A-5A-46E	46						-90	TDD
CA_2A-5A-46A	2			-98	-95	-93.2	-92	FDD
CA_2A-5A-46C	5			-98	-95			
CA_2A-5A-46D	46						-90	
CA_2A-5A-46A-66A	2			-98	-95	-93.2	-92	FDD
CA_2A-5A-46C-66A	5			-98	-95			FDD
CA_2A-5A-46D-66A	46						-90	TDD
CA_2A-5A-46E-66A	66			-99.5	-96.5	-94.7	-93.5	FDD
CA_2A-5A-46A-66A-66A	66			-99.5	-96.5	-94.7	-93.5	FDD
CA_2A-5A-46C-66A-66A	66			-99.5	-96.5	-94.7	-93.5	FDD
CA_2A-5A-46D-66A-66A	66			-99.5	-96.5	-94.7	-93.5	FDD
CA_2A-7A-46A-66A	2			-98	-95	-93.2	-92	FDD
CA_2A-7A-46A-66A	7			-98	-95	-93.2	-92	
CA_2A-7A-46A-66A	46				-93		-90	TDD
CA_2A-7A-46A-66A	66			-99.5	-96.5	-94.7	-93.5	FDD
CA_2A-13A-46A	2			-98	-95	-93.2	-92	FDD
CA_2A-13A-46A	13			-97	-94			
CA_2A-13A-46A	46						-90	
CA_1A-7A-46A	1			-100	-97	-95.2	-94	FDD
CA_1A-7A-46C	7			-98	-95	-93.2	-92	FDD
CA_1A-7A-46D	46						-90	TDD
CA_1A-7A-46E	46							
CA_1A-7A-46E	1			-100	-97	-95.2	-94	FDD



CA_1A-46A CA_1A-46C CA_1A-46D CA_1A-46E	46				-93		-90	TDD			
CA_2A-5A-46C	2			-98	-95	-93.2	-92	FDD			
	5			-98	-95			FDD			
	46						-90	TDD			
CA_2A-5A-46D CA_2A-5A-46E	2			-98	-95	-93.2	-92	FDD			
	5			-98	-95						
	46						-90				
CA_2A-7A-46A CA_2A-7A-46A	2			-98	-95	-93.2	-92	FDD			
	7			-98	-95	-93.2	-92				
CA_2A-7A-46C CA_2A-7A-7A-46C CA_2A-7A-46D CA_2A-7A-7A-46D CA_2A-7A-46E CA_2A-7A-7A-46E	46				-93		-90	TDD			
CA_2A-13A-46C	2			-98	-95	-93.2	-92	FDD			
	13			-97	-94			FDD			
	46						-90	TDD			
CA_2A-13A-46A-66A CA_2A-13A-46C-66A CA_2A-13A-46D-66A CA_2A-13A-46A-66A-66A CA_2A-13A-46C-66A-66A CA_2A-13A-46D-66A-66A	2			-98	-95	-93.2	-92	FDD			
	13			-97	-94			FDD			
	46						-90	TDD			
	66			-99.5	-96.5	-94.7	-93.5	FDD			
CA_2A-46A CA_2A-46E CA_2A-2A-46A CA_2A-2A-46D CA_2A-46C CA_2A-46A-46A CA_2A-2A-46C CA_2A-46A-46C CA_2A-46D CA_2A-46A-46D	2			-98	-95	-93.2	-92	FDD			
	46							-90	TDD		
		2			-97.8	-94.8	-93.0			-91.7	FDD
		46								-83	TDD

CA_2A-46A-48A <sup>10,11</sup>								
CA_2A-46A-48C <sup>10,11</sup>								
CA_2A-46A-48D <sup>10,11</sup>								
CA_2A-46A-48E <sup>10,11</sup>								
CA_2A-46C-48A <sup>10,11</sup>								
CA_2A-46C-48C <sup>10,11</sup>	48			-71.7	-71.7	-71.7	-71.7	TDD
CA_2A-46C-48D <sup>10,11</sup>								
CA_2A-46C-48E <sup>10,11</sup>								
CA_2A-46D-48A <sup>10,11</sup>								
CA_2A-46D-48C <sup>10,11</sup>								
CA_2A-46E-48A <sup>10,11</sup>								
CA_2A-46E-48C <sup>10,11</sup>								
CA_2A-46A-48A <sup>12</sup>	2			-97.8	-94.8	-93.0	-91.7	FDD
CA_2A-46A-48C <sup>12</sup>	46						-83	TDD
CA_2A-46A-48D <sup>12</sup>								
CA_2A-46A-48E <sup>12</sup>								
CA_2A-46C-48A <sup>12</sup>								
CA_2A-46C-48C <sup>12</sup>								
CA_2A-46C-48D <sup>12</sup>	48			-97.1	-94.7	-93.2	-92.5	TDD
CA_2A-46C-48E <sup>12</sup>								
CA_2A-46D-48A <sup>12</sup>								
CA_2A-46E-48A <sup>12</sup>								
CA_2A-46D-48C <sup>12</sup>								
CA_2A-46E-48C <sup>12</sup>								
CA_2A-46A-48A-66A <sup>10,11</sup>	2			-97.7	-94.7	-92.9	-91.7	FDD
CA_2A-46A-48C-66A <sup>10,11</sup>	46						-83	TDD
CA_2A-46A-48D-66A <sup>10,11</sup>	48			-71.7	-71.7	-71.7	-71.7	TDD
CA_2A-46C-48A-66A <sup>10,11</sup>								
CA_2A-46C-48C-66A <sup>10,11</sup>								
CA_2A-46C-48D-66A <sup>10,11</sup>	66			-99.3	-96.3	-94.5	-93.3	FDD
CA_2A-46D-48A-66A <sup>10,11</sup>								
CA_2A-46D-48C-66A <sup>10,11</sup>								
CA_2A-46E-48A-66A <sup>10,11</sup>								
CA_2A-46E-48C-66A <sup>10,11</sup>								
	2			-97.7	-94.7	-92.9	-91.7	FDD
	46						-83	TDD

CA_2A-46A-48A-66A <sup>12</sup>	48			-97.1	-94.7	-93.2	-92.5	TDD
CA_2A-46A-48D-66A <sup>12</sup>								
CA_2A-46C-48C-66A <sup>12</sup>								
CA_2A-46C-48D-66A <sup>12</sup>	66			-99.3	-96.3	-94.5	-93.3	FDD
CA_2A-46D-48A-66A <sup>12</sup>								
CA_2A-46D-48C-66A <sup>12</sup>								
CA_2A-46E-48A-66A <sup>12</sup>								
CA_2A-46A-48C-66A <sup>12</sup>	2			-97.7	-94.7	-92.9	-91.7	FDD
CA_2A-46C-48A-66A <sup>12</sup>	46						-83	TDD
CA_2A-46C-48A-66A <sup>12</sup>	48			-71.7	-71.7	-71.7	-71.7	TDD
CA_2A-46C-48A-66A <sup>12</sup>	66			-99.3	-96.3	-94.5	-93.3	FDD
CA_2A-46A-66A	2			-98	-95	-93.2	-92	FDD
CA_2A-46A-66A	46						-90	TDD
CA_2A-46A-66A	66			-99.5	-96.5	-94.7	-93.5	FDD
CA_2A-46A-46A-66A	2			-98	-95	-93.2	-92	FDD
CA_2A-46C-66A	46						-90	TDD
CA_2A-46C-66A	66			-99.5	-96.5	-94.7	-93.5	FDD

CA_2A-46A-46C-66A	2			-98	-95	-93.2	-92	FDD
CA_2A-46D-66A	46						-90	TDD
CA_2A-46E-66A								
CA_2A-46A-66A-66A, CA_2A-46C-66A-66A, CA_2A-46D-66A-66A, CA_2A-46E-66A-66A	66			-99.5	-96.5	-94.7	-93.5	FDD
CA_2A-49A <sup>9</sup>	2			-97.8	-94.8	-93.0	-91.7	FDD
	49				-95.5		-92.5	TDD
CA_3A-7A-46C	3			-97	-94	-92.2	-91	FDD
	7			-98	-95	-93.2	-92	FDD
	46						-90	TDD
CA_3A-7A-46D	3			-97	-94	-92.2	-91	FDD
	7			-98	-95	-93.2	-92	FDD
	46						-90	TDD
CA_3A-7A-46E	3			-97	-94	-92.2	-91	FDD
	7			-98	-95	-93.2	-92	FDD
	46						-90	TDD
CA_3A-46A CA_3A-46C CA_3A-46D CA_3A-46E	3		-98.7	-97	-94	-92.2	-91	FDD
	46				-93		-90	TDD
CA_3C-46A	3			-97	-94	-92.2	-91	FDD
	46						-90	TDD
CA_3A-3A-46A CA_3C-46C CA_3C-46D CA_3A-3A-46C	3			-97	-94	-92.2	-91	FDD
	46						-90	TDD
CA_3A-7A-46A CA_3A-7C-46A CA_3A-7C-46C CA_3A-7C-46D CA_3A-7C-46E	3			-97	-94	-92.2	-91	FDD
	7			-98	-95	-93.2	-92	FDD
	46						-90	TDD
CA_3A-32A-46A CA_3A-32A-46C CA_3A-32A-46D CA_3A-32A-46E	3			-97	-94	-92.2	-91	FDD
	32			-100	-97	-95.2	-94	SDL
	46						-90	TDD
CA_3A-7A-32A-46A CA_3A-7A-32A-46C CA_3A-7A-32A-46D CA_3A-7A-32A-46E	3			-97	-94	-92.2	-91	FDD
	7				-95	-93.2	-92	FDD
	32			-100	-97	-95.2	-94	FDD
	46						-90	TDD

CA_4A-46A CA_4A-46C	4			-100	-97	-95.2	-94	FDD
CA_4A-46A-46A CA_4A-46A-46C CA_4A-46D CA_4A-46A-46D	46						-90	TDD
CA_5A-7A-46A	5			-98	-95			FDD
CA_5A-7A-46C	7				-95	-93.2	-92	FDD
CA_5A-7A-46D	46						-90	TDD
CA_5A-7A-46D	46						-90	TDD
CA_5A-12A-46A, CA_5A-12A-46C, CA_5A-12A-46D	5			-98	-95			FDD
	12			-97	-94			
	46						-90	TDD
CA_5A-46A CA_5A-46C CA_5A-46D CA_5A-46E CA_5B-46A CA_5B-46C CA_5B-46D CA_5B-46E	5			-98	-95			FDD
	46				-93		-90	TDD
CA_5A-46A-66A	5			-98	-95			FDD
	46						-90	FDD
	66			-99.5	-96.5	-94.7	-93.5	
CA_5A-46C-66A	5			-98	-95			FDD
	46						-90	TDD
	66			-99.5	-96.5	-94.7	-93.5	FDD
CA_5A-46D-66A, CA_5A-46E-66A, CA_5A-46A-66A-66A, CA_5A-46C-66A-66A, CA_5A-46D-66A-66A, CA_5A-46E-66A-66A	5			-98	-95			FDD
	46						-90	
	66			-99.5	-96.5	-94.7	-93.5	FDD
CA_7A-46A CA_7A-46C CA_7A-7A-46C CA_7A-46D CA_7A-46E CA_7C-46A CA_7C-46C CA_7C-46D CA_7C-46E	7			-98	-95	-93.2	-92	FDD
	46				-93		-90	TDD
CA_7A-7A-46A CA_7A-7A-46D CA_7A-7A-46E	7			-98	-95	-93.2	-92	FDD
	46						-90	TDD
	7				-95	-93.2	-92	FDD
	32			-100	-97	-95.2	-94	SDL

CA_7A-32A-46A CA_7A-32A-46C CA_7A-32A-46D CA_7A-32A-46E	46							-90	TDD
CA_7A-46A-66A	7			-97.5	-94.5	-92.7		-91.5	FDD
	46				-93			-90	TDD
	66			-99	-96	-94.2		-93	FDD
CA_8A-46A CA_8A-46D CA_8A-46E CA_8B-46C CA_8B-46D	8	-102.2	-99.2	-97	-94				FDD
	46							-90	TDD
CA_8A-46C	8	-102.2	-99.2	-97	-94				FDD
	46							-90	TDD
CA_8B-46A	8	-102.2	-99.2	-97	-94				FDD
	46							-90	TDD
CA_11A-46A	11			-100	-97				FDD
	46							-90	TDD
CA_11A-46C	11			-100	-97				FDD
	46							-90	TDD
CA_11A-46D	11			-100	-97	-95.2			FDD
	46							-90	TDD
CA_11A-46E	11			-100	-97				FDD
	46							-90	TDD
CA_12A-46A CA_12A-46C CA_12A-46D	12			-97	-94				FDD
	46							-90	TDD
CA_12A-46E	12			-97	-94				FDD
	46							-90	TDD
CA_13A-46A CA_13A-46A-46A CA_13A-46A-46C CA_13A-46A-46D CA_13A-46C CA_13A-46D CA_13A-46E	13			-97	-94				FDD
	46							-90	TDD
CA_13A-46A-66A CA_13A-46C-66A CA_13A-46D-66A CA_13A-46A-66A-66A CA_13A-46C-66A-66A CA_13A-46D-66A-66A CA_13A-46E-66A	13			-97	-94				FDD
	46							-90	TDD
CA_13A-46A-66A-66A CA_13A-46C-66A-66A CA_13A-46D-66A-66A CA_13A-46E-66A	66			-99.5	-96.5	-94.7		-93.5	FDD
	19			-100	-97	-95.2			FDD
CA_19A-46A CA_19A-46C CA_19A-46D CA_19A-46E	46							-90	TDD
	21			-100	-97	-95.2			FDD

CA_21A-46A CA_21A-46C CA_21A-46D CA_21A-46E	46							-90	TDD
CA_25A-46A CA_25A-46C CA_25A-46D	25	-101.2	-98.2	-96.5	-93.5	-91.7	-90.5		FDD
	46				-93		-90		TDD
CA_26A-46A	26		-99.7	-97.5 <sup>7</sup>	-94.5 <sup>7</sup>				FDD
	46						-90		TDD
CA_28A-46A CA_28A-46C CA_28A-46D CA_28A-46E	28			-98.5	-95.5	-93.7	-91		FDD
	46				-93		-90		TDD
CA_29A-46A- 66A	29			-97	-94				FDD
	46						-90		TDD
	66			-99.5	-96.5	-94.7	-93.5		FDD
CA_39A-46A	39			-100	-97	-95.2	-94		TDD
	46						-90		TDD
CA_39A-46C	39			-100	-97	-95.2	-94		TDD
	46						-90		TDD
CA_39C-46A	39			-100	-97	-95.2	-94		TDD
	46						-90		TDD
CA_39A-46E CA_39C-46C CA_39C-46D	39			-100	-97	-95.2	-94		TDD
	46						-90		

CA_40A-46A	40			-100	-97	-95.2	-94	TDD
CA_40A-46D								
CA_40A-46E								
CA_40C-46C	46				-93		-90	TDD
CA_40C-46D								
CA_40D-46A								
CA_40D-46C								
CA_40A-46C	40			-100	-97	-95.2	-94	TDD
	46						-90	TDD
CA_40C-46A	40			-100	-97	-95.2	-94	TDD
	46						-90	TDD
CA_41A-46A	41			-98	-95	-93.2	-92	TDD
CA_41A-46C								
CA_41A-46D								
CA_41A-46E								
CA_41C-46A	46						-90	TDD
CA_41C-46C								
CA_41C-46D								
CA_41D-46A								
CA_41D-46C								
CA_42A-46A	42			-99	-96	-94.2	-93	TDD
	46						-83	TDD
CA_46A-48A	46						-83	TDD
CA_46A-48A-48A								
CA_46A-48C								
CA_46A-48D								
CA_46A-48E								
CA_46C-48A								
CA_46C-48A-48A								
CA_46C-48C	48			-99	-96	-94.2	-93	TDD
CA_46C-48D								
CA_46C-48E								
CA_46D-48A								
CA_46D-48C								
CA_46D-48A-48A								
CA_46E-48A								
CA_46E-48C								
CA_46A-48A-66A <sup>10,11</sup>	46						-83	FDD
CA_46A-48C-66A <sup>10,11</sup>	48			-71.7	-71.7	-71.7	-71.7	TDD
CA_46A-48D-66A <sup>10,11</sup>								
CA_46A-48E-66A <sup>10,11</sup>								
CA_46C-48A-66A <sup>10,11</sup>								
CA_46C-48C-66A <sup>10,11</sup>								
CA_46C-48D-66A <sup>10,11</sup>	66			-99.3	-96.3	-94.5	-93.2	FDD
CA_46C-48E-66A <sup>10,11</sup>								
CA_46D-48A-66A <sup>10,11</sup>								
CA_46D-48C-66A <sup>10,11</sup>								
CA_46E-48A-66A <sup>10,11</sup>								
CA_46E-48C-66A <sup>10,11</sup>								
	46						-83	FDD
	48			-97.1	-94.7	-93.2	-92.5	TDD



CA_46A-48A-66A <sup>12</sup>								
CA_46A-48C-66A <sup>12</sup>								
CA_46A-48D-66A <sup>12</sup>								
CA_46A-48E-66A <sup>12</sup>								
CA_46C-48A-66A <sup>12</sup>								
CA_46C-48C-66A <sup>12</sup>	66			-99.3	-96.3	-94.5	-93.2	FDD
CA_46C-48D-66A <sup>12</sup>								
CA_46C-48E-66A <sup>12</sup>								
CA_46D-48A-66A <sup>12</sup>								
CA_46D-48C-66A <sup>12</sup>								
CA_46E-48A-66A <sup>12</sup>								
CA_46E-48C-66A <sup>12</sup>								
CA_46A-48A-71A	46						-83	TDD
CA_46A-48A-48A-71A	48			-99	-96	-94.2	-93	TDD
CA_46A-48C-71A								
CA_46C-48A-71A	71			-97.2	-94.2	-92.0	-87.5	FDD
CA_46C-48C-71A								
CA_46C-48A-48A-71A								

CA_46A-66A	46						-90	TDD
CA_46A-46A-66A								
CA_46A-66A-66A								
CA_46A-66C								
CA_46A-46C-66A								
CA_46A-46D-66A								
CA_46C-66A	66			-99.5	-96.5	-94.7	-93.5	FDD
CA_46C-66A-66A								
CA_46D-66A								
CA_46D-66A-66A								
CA_46E-66A								
CA_46E-66A-66A								
CA_46A-70A	46						-90	TDD
	70			-100	-97	-95.2		FDD
CA_46A-71A	46						-90	FDD
CA_46C-71A								
CA_46D-71A	71			-97.2	-94.2	-92.0	-87.5	TDD

- NOTE 1: The transmitter shall be set to  $P_{UMAX}$  as defined in subclause 6.2.5A.
- NOTE 2: Reference measurement channel is A.3.2 with one sided dynamic OCNG Pattern OP.1 FDD/TDD/FS3 as described in Annex A.5.1.1/A.5.2.1/A.5.4.1.
- NOTE 3: The signal power is specified per port.
- NOTE 4: Void
- NOTE 5: The requirement for B46 does not apply when there is at least one individual RE within the B46 downlink transmission bandwidth which falls into the reference sensitivity exclusion region as specified in Table 7.3.1A-0eC.
- NOTE 6: Void
- NOTE 7: <sup>7</sup> indicates that the requirement is modified by -0.5 dB when the carrier frequency of the assigned E-UTRA channel bandwidth is within 865-894 MHz.
- NOTE 8: When Band 46 have self interference problems by dual uplink CA, then the requirements not apply in exclusion zone which is frequency range within (harmonics frequency region +  $\Delta F_{HD}$ ) and IMD frequency region as follow.
- NOTE 9: The requirement for B49 does not apply when there is at least one individual RE within the B49 downlink transmission bandwidth which falls into the reference sensitivity exclusion region as specified in Table 7.3.1A-0eD.
- NOTE 10: These requirements apply when there is at least one individual RE within the uplink transmission bandwidth of the aggressor (lower) band for which the 2nd transmitter harmonic is within the downlink transmission bandwidth of a victim (higher) band which excludes band 46 and a range  $\Delta F_{HD}$  above and below the edge of this downlink transmission bandwidth. The value  $\Delta F_{HD}$  depends on the E-UTRA configuration:  $\Delta F_{HD} = 10$  MHz for CA\_2-46-48, CA\_4-48-66, and CA\_2-46-48-66. For harmonic issue not related with band 46, the uplink configuration of CA\_2-48, CA\_48-66 and CA\_2-48-66 in Table 7.3.1A-0b can be used.
- NOTE 11: The requirements should be verified for UL EARFCN of the aggressor (lower) band (superscript LB) such that  $f_{UL}^{LB} = f_{DL}^{HB} / 0.2$  in MHz and

$$F_{UL\_low}^{LB} + BW_{Channel}^{LB} / 2 \leq f_{UL}^{LB} \leq F_{UL\_high}^{LB} - BW_{Channel}^{LB} / 2 \text{ with } f_{DL}^{HB} \text{ carrier frequency in the victim (higher) band in MHz and } BW_{Channel}^{LB} \text{ the channel bandwidth configured in the lower band.}$$

- NOTE 12: The requirements are only applicable to channel bandwidths with a carrier frequency at  $\pm(20 + BW_{Channel}^{HB} / 2)$  MHz offset from  $2f_{UL}^{LB}$  in the victim (higher band) with

$$F_{UL\_low}^{LB} + BW_{Channel}^{LB} / 2 \leq f_{UL}^{LB} \leq F_{UL\_high}^{LB} - BW_{Channel}^{LB} / 2, \text{ where } BW_{Channel}^{LB} \text{ and } BW_{Channel}^{HB} \text{ are the channel bandwidths configured in the aggressor (lower) and victim (higher) bands in MHz, respectively.}$$

IMD frequency range

DL_CA configuration	UL_CA configuration	Exclusion zone center frequency	Exclusion zone BW
CA_1A-3A-46A	CA_1A-3A	$2*fc\_1A + fc\_3A$	$2*BW\_1A + BW\_3A$
CA_1A-3A-46A	CA_1A-3A	$fc\_1A - 2*fc\_3A$	$BW\_1A + 2*BW\_3A$

IMD frequency range

DL_CA configuration	UL_CA configuration	Exclusion zone center frequency	Exclusion zone BW
CA_1A-5A-46A	CA_1A-5A	$2*fc\_1A + 2*fc\_5A$	$2*BW\_1A + 2*BW\_5A$
CA_1A-7A-46A	CA_1A-7A	$3*fc\_7A - fc\_1A$	$3*BW\_7A + BW\_1A$
CA_5A-7A-46A	CA_5A-7A	$2*fc\_7A + fc\_5A$	$2*BW\_7A + BW\_5A$

IMD frequency range

DL_CA configuration	UL_CA configuration	Exclusion zone center frequency	Exclusion zone BW
CA_2A-5A-46D	CA_2A-5A	$3*fc\_5A + 1*fc\_2A$	$3*BW\_5A + 1*BW\_2A$
CA_2A-5A-46D	CA_2A-5A	$2*fc\_5A - 3*fc\_2A$	$2*BW\_5A + 3*BW\_2A$

IMD frequency range

DL_CA configuration	UL_CA configuration	Exclusion zone center frequency	Exclusion zone BW
CA_5A-46D-66A	CA_5A-66A	$3*fc\_66A + 1*fc\_5A$	$3*BW\_66A + 1*BW\_5A$
CA_5A-46D-66A	CA_5A-66A	$2*fc\_66A - 3*fc\_5A$	$2*BW\_66A + 3*BW\_5A$
CA_5A-46D-66A	CA_5A-66A	$2*fc\_66A + 3*fc\_5A$	$2*BW\_66A + 3*BW\_5A$

IMD frequency range

DL_CA configuration	UL_CA configuration	Exclusion zone center frequency	Exclusion zone BW
CA_13A-46D-66A	CA_13A-66A	$2*fc\_66A + 2*fc\_13A$	$2*BW\_66A + 2*BW\_13A$
CA_13A-46D-66A	CA_13A-66A	$2*fc\_66A + 3*fc\_13A$	$2*BW\_66A + 3*BW\_13A$

IMD frequency range			
DL_CA configuration	UL_CA configuration	Exclusion zone center frequency	Exclusion zone BW
CA_2A-13A-46D CA_2A-13A-46A-46D CA_2A-13A-46A-46C CA_2A-13A-46C CA_2A-13A-46A-46A CA_2A-13A-46A CA_2A-13A-46E	CA_2A-13A	$3*fc_{13A} + 1*fc_{2A}$	$3*BW_{13A} + 1*BW_{2A}$
IMD frequency range			
DL_CA configuration	UL_CA configuration	Exclusion zone center frequency	Exclusion zone BW
CA_2A-46E-66A CA_2A-46D-66A CA_2A-46C-66A CA_2A-46A-66A	CA_2A-66A	$2*fc_{2A} + 1*fc_{66A}$ $2*fc_{66A} + 1*fc_{2A}$ $1*fc_{2A} - 4*fc_{66A}$ $1*fc_{66A} - 4*fc_{2A}$	$2*BW_{2A} + 1*BW_{66A}$ $2*BW_{66A} + 1*BW_{2A}$ $1*BW_{2A} + 4*BW_{66A}$ $1*BW_{66A} + 4*BW_{2A}$
IMD frequency range			
DL_CA configuration	UL_CA configuration	Exclusion zone center frequency	Exclusion zone BW
CA_2A-46E-48A, CA_2A-46D-48A CA_2A-46D-48C CA_2A-46C-48C CA_2A-46A-48C CA_2A-46C-48A CA_2A-46A-48A	CA_2A-48A	$1*fc_{2A} + 1*fc_{48A}$ $2*fc_{48A} - 1*fc_{2A}$	$1*BW_{2A} + 1*BW_{48A}$ $2*BW_{48A} + 1*BW_{2A}$
IMD frequency range			
DL_CA configuration	UL_CA configuration	Exclusion zone center frequency	Exclusion zone BW
CA_46D-48C-66A CA_46C-48C-66A CA_46A-48C-66A CA_46D-48A-66A CA_46C-48A-66A CA_46A-48A-66A	CA_48A-66A	$1*fc_{48A} + 1*fc_{66A}$ $2*fc_{48A} - 1*fc_{66A}$	$1*BW_{48A} + 1*BW_{66A}$ $2*BW_{48A} + 1*BW_{66A}$

Table 7.3.1A-0eB: Void

Table 7.3.1A-0eC specifies the Band 46 reference measurement exclusion region for different licensed component carriers and channel bandwidth. The exclusion region is defined according to the licensed component carrier channel bandwidth. The UL configurations to be adopted for the test are specified in Table 7.3.1-2. The exclusion region in Table 7.3.1A-0eC is specified for the case of 10MHz and 20MHz channel bandwidth in Band 46.

**Table 7.3.1A-0eC: Band 46 Reference sensitivity measurement exclusion region in MHz.**

Licensed Component Carriers / E-UTRA Band / Harmonic order / Channel BW in UL					
Licensed Component Carriers	Harmonic order	5MHz	10MHz	15MHz	20MHz
1	3	+/- 15	+/- 23	+/- 35	+/- 45
2	3	+/- 15	+/- 23	+/- 35	+/- 45
3	3	+/- 15	+/- 23	+/- 35	+/- 45
4	3	+/- 15	+/- 23	+/- 35	+/- 45
5	7	+/- 10	+/- 20		
7 <sup>1</sup>	2	+/- 15	+/- 25	+/- 38	+/- 50
8	6	+/- 10	+/- 20		
11	4	+/- 15	+/- 25		
12	8	+/- 10	+/- 20		
13	7	+/- 10	+/- 20		
19	7	+/- 10	+/- 20	+/- 30	
21	4	+/- 15	+/- 25	+/- 38	
25	3	+/- 15	+/- 23	+/- 35	+/- 45
26	7	+/- 10	+/- 20	+/- 30	
28	7	+/- 10	+/- 20	+/- 30	+/- 40
28	8	+/- 10	+/- 20	+/- 30	+/- 40
39	3	+/- 15	+/- 23	+/- 35	+/- 45
41	2	+/- 15	+/- 25	+/- 38	+/- 50
66	3	+/- 15	+/- 23	+/- 35	+/- 45

NOTE 1: Even though UL harmonic does not fall directly into Band 46 the exclusion region still applies.  
NOTE 2: The center of the exclusion region is obtained by multiplying the UL channel center frequency by the harmonic order.

Table 7.3.1A-0eD specifies the Band 49 reference measurement exclusion region for different licensed component carriers and channel bandwidth. The exclusion region is defined according to the licensed component carrier channel bandwidth. The UL configurations to be adopted for the test are specified in Table 7.3.1-2.

**Table 7.3.1A-0eD: Band 49 reference sensitivity measurement exclusion region in MHz.**

Licensed Component Carriers / E-UTRA Band / Harmonic order / Channel BW in UL					
Licensed Component Carriers	Harmonic order	5MHz	10MHz	15MHz	20MHz
2 <sup>1</sup>	2	+/- 12.5	+/- 25	+/- 37.5	+/- 50

NOTE 1: Even though UL harmonic does not fall directly into Band 49 the exclusion region still applies.  
NOTE 2: The center of the exclusion region is obtained by multiplying the UL channel center frequency by the harmonic order.

In all cases for single uplink inter-band CA, unless given by Table 7.3.1-3 for the band with the active uplink carrier, the applicable reference sensitivity requirements shall be verified with the network signalling value NS\_01 (Table 6.2.4-1) configured.

For inter-band carrier aggregation with one component carrier per operating band (up to four downlinks) and the uplink assigned to two E-UTRA bands the throughput shall be  $\geq 95\%$  of the maximum throughput of the reference measurement channels as specified in Annexes A.2.2, A.2.3 and A.3.2 (with one sided dynamic OCN Pattern OP.1 FDD/TDD for the DL-signal as described in Annex A.5.1.1/A.5.2.1) with parameters specified in Table 7.3.1-1, Table 7.3.1-1a and Table 7.3.1-2. The reference sensitivity is defined to be met with all downlink component carriers active and both of the uplink carriers active.

For E-UTRA CA configurations with uplink and downlink assigned to two E-UTRA bands given in Table 7.3.1A-0f, the reference sensitivity is defined only for the specific uplink and downlink test points which are specified in Table 7.3.1A-0f. For E-UTRA CA configurations with uplink assigned to two E-UTRA bands and downlink assigned to three E-UTRA bands given in Table 7.3.1A-0g, the reference sensitivity is defined only for the specific uplink and downlink test points which are specified in Table 7.3.1A-0g. For these test points the reference sensitivity requirement specified in Table 7.3.1-1 and Table 7.3.1-1a are relaxed by the amount of the corresponding parameter MSD given in Table 7.3.1A-0f and Table 7.3.1A-0g.

The allowed exceptions defined in Table 7.3.1A-0a and Table 7.3.1A-0b for inter-band carrier aggregation with a single active uplink are also applicable for dual uplink operation.

**Table 7.3.1A-0f: 2DL/2UL interband Reference sensitivity QPSK  $P_{\text{REFSENS}}$  and uplink/downlink configurations**

E-UTRA Band / Channel bandwidth / $N_{\text{RB}}$ / Duplex mode								Source of IMD
EUTRA CA Configuration	EUTRA band	UL $F_c$ (MHz)	UL/DL BW (MHz)	UL $C_{\text{LRB}}$	DL $F_c$ (MHz)	MSD (dB)	Duplex mode	
CA_1A-3A	1	1950	5	25	2140	23	FDD	IMD3
	3	1760	5	25	1855	N/A		N/A
CA_1A-8A	1	1965	5	25	2155	6	FDD	IMD4
	8	887.5	5	25	932.5	N/A		N/A
CA_2A-4A	2	1860	20	50 <sup>2</sup>	1940	5	FDD	IMD3
	4	1752.5	5	25	2152.5	N/A		N/A
CA_2A-4A	2	1868.3	5	25	1948.3	N/A	FDD	N/A
	4	1735	5	25	2135	5		IMD5
CA_2A-46A	2	1880	5	25	1960	12.0	FDD	IMD3 <sup>4</sup>
	46	5720	20	100	5720	N/A		N/A
CA_2A-48A	2	1852.5	5	25	1932.5	[12]	FDD	IMD4
	48	3625	20	100	3625	N/A		TDD
CA_2A-49A	2	1852.5	5	25	1932.5	[12]	FDD	IMD4
	49	3625	20	100	3625	N/A		TDD
CA_2A-66A	2	1855	5	25	1935	20	FDD	IMD3
	66	1775	5	25	2175	N/A		N/A
CA_2A-66A	2	1883.3	5	25	1963.3	N/A	FDD	N/A
	66	1750	5	25	2150	4		IMD5
CA_3A-5A	3	1771	10	50	1866	4	FDD	IMD4
	5	838	5	25	883	N/A		N/A
CA_3A-5A	3	1721	10	50	1816	N/A	FDD	N/A
	5	838	5	25	883	24		IMD2 <sup>4</sup>
CA_3A-7A	3	1730	5	25	1825	N/A	FDD	N/A
	7	2535	10	50	2655	13		IMD4
CA_3A-8A	3	1755	10	50	1850	N/A	FDD	N/A
	8	900	5	25	945	8		IMD4 <sup>4</sup>
CA_3A-8A	3	1747.5	10	50	1842.5	6.4	FDD	IMD5
	8	897.5	5	25	942.5	N/A		N/A
CA_3A-18A	3	1721	5	25	1816	4	FDD	IMD4
	18	823	5	25	868	N/A		N/A
CA_3A-19A	3	1771	5	25	1866	4	FDD	IMD4
	19	838	5	25	883	N/A		N/A
CA_3A-19A	3	1721	5	25	1816	N/A	FDD	N/A
	19	838	5	25	883	27		IMD2 <sup>4</sup>
CA_3A-20A	3	1775	5	25	1870	4	FDD	IMD4
	20	840	5	25	799	N/A		N/A
CA_3A-20A	3	1735	5	25	1830	N/A	FDD	N/A
	20	847	5	25	806	9		IMD4
CA_3A-26A	3	1771	5	25	1866	4	FDD	IMD4
	26	838	5	25	883	N/A		N/A
CA_3A-26A	3	1721	5	25	1816	N/A	FDD	N/A
	26	838	5	25	883	26		IMD2 <sup>4</sup>
CA_3A-41A	3	1740	5	25	1835	8.2	FDD	IMD4
	41	2657.5	5	25	2657.5	N/A		TDD
CA_3A-42A	3	1740	5	25	1835	29.8	FDD	IMD2 <sup>4</sup>
	42	3575	5	25	3575	N/A		TDD
CA_3A-42A	3	1765	5	25	1860	8.0	FDD	IMD4 <sup>4</sup>
	42	3435	5	25	3435	N/A		TDD
CA_4A-5A	4	1721	5	25	2121	N/A	FDD	N/A
	5	838	5	25	883	26		IMD2 <sup>4</sup>
CA_4A-7A	4	1730	5	25	2130	N/A	FDD	N/A
	7	2535	5	25	2655	15		IMD4
CA_5A-7A	5	834	5	25	879	12	FDD	IMD3 <sup>4</sup>
	7	2547	10	50	2667	N/A		N/A
CA_5A-66A	5	838	5	25	883	30	FDD	IMD2 <sup>4</sup>
	66	1721	5	25	2121	N/A		N/A
CA_7A-20A	7	2512	10	50	2632	N/A	FDD	N/A
	20	851	5	25	810	12		IMD3 <sup>4</sup>

CA_7A-26A	7	2556	5	25	2676	N/A	FDD-	N/A
	26	837	5	25	882	16.0	FDD	IMD3
CA_8A-41A	7	2567.5	5	25	2687.5	2.5	FDD-	IMD5
	26	816.5	5	25	861.5	N/A	FDD	N/A
CA_19A-42A <sup>3</sup>	8	882.5	5	25	927.5	12.1	FDD	IMD3 <sup>4</sup>
	41	2685	10	50	2685	N/A	TDD	N/A
CA_21A-28A	19	N/A	N/A	N/A	N/A	N/A	FDD	N/A
	42	N/A	N/A	N/A	N/A	N/A	TDD	N/A
CA_21A-28A	21	1450.4	5	25	1498.4	[2.5]	FDD	IMD5
	28	735.5	5	25	790.5	N/A	TDD	N/A
CA_21A-42A <sup>3</sup>	21	N/A	N/A	N/A	N/A	N/A	FDD	N/A
	42	N/A	N/A	N/A	N/A	N/A	TDD	N/A
CA_28A-42A	28	705.5	5	25	760.5	[5.5]	FDD	IMD5
	42	3582.5	5	25	3582.5	N/A	TDD	N/A
CA_40A-42A	40	2350	5	25	2350	N/A	TDD	N/A
	42	3500	5	25	3550	5		IMD4
	40	2350	5	25	2350	5	TDD	IMD4
	42	3525	5	25	3525	N/A		N/A
NOTE 1: Both of the transmitters shall be set min(+20 dBm, P <sub>CMAX,L,c</sub> ) as defined in subclause 6.2.5A								
NOTE 2: RB <sub>START</sub> = 0								
NOTE 3: No requirements apply when there is at least one individual RE within the intermodulation generated by the dual uplink is within the downlink transmission bandwidth of the FDD band. The reference sensitivity should only be verified when this is not the case (the requirements specified in clause 7.3.1 apply).								
NOTE 4: This band is subject to IMD5 also which MSD is not specified.								
NOTE 5: Void								
NOTE 6: For operations with 4 antenna ports, the MSD in the applicable bands shall be modified by the absolute value of ΔR <sub>IB,4R</sub> in Table 7.3.1-1a when MSD > 0.								



**Table 7.3.1A-0g: 3DL/2UL interband Reference sensitivity QPSK  $P_{\text{REFSENS}}$  and uplink/downlink configurations**

E-UTRA Band / Channel bandwidth / NRB / Duplex mode										Source of IMD
EUTRA CA	EUTRA CA	EUTRA band	UL F <sub>c</sub>	UL BW	UL	DL F <sub>c</sub>	DL BW	MSD	Duplex mode	
DL Configuration	UL Configuration		(MHz)	(MHz)	C <sub>LRB</sub>	(MHz)	(MHz)	(dB)		
CA_1A-3A-28A	CA_1A-28A	1	1975	5	25	2165	5	N/A	FDD	N/A
		28	710.5	5	25	765.5	5	N/A		N/A
		3	1723.5	5	25	1818.5	5	4.0		IMD5
	CA_3A-28A	3	1780	5	25	1875	5	N/A	FDD	N/A
		28	710.5	5	25	765.5	5	N/A		N/A
		1	1949	5	25	2139	5	11.0		IMD4
CA_1A-3A-40A	CA_1A-3A	1	1950	5	25	2140	5	N/A	FDD	N/A
		3	1735	5	25	1830	5	N/A	FDD	N/A
		40	2380	5	25	2380	5	8.0	TDD	IMD5
CA_1A-3A-41A	CA_1A-3A	1	1977.5	5	25	2167.5	5	N/A	FDD	N/A
		3	1712.5	5	25	1807.5	5	N/A	FDD	N/A
		41	2507.5	5	25	2507.5	5	5.0	TDD	IMD5
CA_1A-3A-42A	CA_1A-3A	1	1922.5	5	25	2112.5	5	N/A	FDD	N/A
		3	1782.5	5	25	1877.5	5	N/A	FDD	N/A
		42				3425	5	13.0	TDD	IMD4
CA_1A-5A-7A	CA_1A-7A	1	1968	5	25	2158	5	N/A	FDD	N/A
		7	2512	10	50	2632	10	N/A		N/A
		5	835	5	25	880	5	1.0		IMD5
CA_1A-5A-40A	CA_1A-5A	1	1977.5	5	25	2167.5	5	N/A	FDD	N/A
		5	826.5	5	25	871.5	5	N/A	FDD	N/A
		40	2305	10	50	2305	10	9.0	TDD	IMD4
CA_1A-7A-26A	CA_1A-7A	1	1965	5	25	2155	5	N/A	FDD	N/A
		7	2510	10	50	2630	10	N/A		N/A
		26	830	5	50	875	5	3.5		IMD5
CA_1A-7A-28A	CA_1A-7A	1	1935	5	25	2125	5	N/A	FDD	N/A
		7	2510	10	50	2630	10	N/A		N/A
		28	730	10	50	785	10	4.5		IMD5
	CA_1A-28A	1	1935	5	25	2125	5	N/A	FDD	N/A
		28	730	10	50	785	10	N/A		N/A
		7	2545	10	50	2665	10	28.0		IMD2
CA_1A-28A-42A	CA_1A-28A	1	1955	5	25	2145	5	N/A	FDD	N/A
		28	735	5	25	790	5	N/A	FDD	N/A
		42	3425	5	25	3425	5	15.0	TDD	IMD3
	CA_28A-42A	28	710.5	5	25	765.5	5	N/A	FDD	N/A
		42	3560	5	25	3560	5	N/A	TDD	N/A
		1	1949	5	25	2139	5	11.0	FDD	IMD3
CA_2A-12A-30A	CA_2A-12A	2	1885	5	25	1965	5	N/A	FDD	N/A
		12	708.5	5	25	738.5	5	N/A		N/A
		30	2308	5	25	2353	5	12.0		IMD4
CA_2A-2A-4A-5A	CA_2A-5A	2	1900	5	25	1980	5	N/A	FDD	N/A
		5	834	5	25	879	5			N/A
		4	1732	5	25	2132	5	7.6		IMD4
CA_2A-4A-13A	CA_2A-13A	2	1855	5	25	1935	5	N/A	FDD	N/A
		13	782	5	25	751	5			N/A
		4	1746	5	25	2146	5	7.6		IMD4

	CA_4A-13A	4	1750	5	25	2150	5	N/A	FDD	N/A
		13	780	5	25	749	5			N/A
		2	1860	5	25	1940	5	6.2		IMD4
CA_2A-2A-5A-66A-66A, CA_2A-5A-66A, CA_2A-5A-66B, CA_2A-5A-66C, CA_2A-5B-66A, CA_2A-5B-66B, CA_2A-5B-66C, CA_2A-2A-5A-66A, CA_2A-2A-5A-66B, CA_2A-2A-5A-66C, CA_2A-5A-66A-66A	CA_2A-5A	2	1900	5	25	1980	5	N/A	FDD	N/A
		5	834	5	25	879	5			N/A
		66	1712	5	25	2132	5	7.2		IMD4
CA_2A-5B-66A-66A	CA_2A-5A	2	1900	5	25	1980	5	N/A	FDD	N/A
		5	834	5	25	879	5			N/A
		66	1712	5	25	2132	5	7.2		IMD4
CA_2A-13A-66A-66B	CA_2A-13A	2	1860	5	25	1940	5	N/A	FDD	N/A
		13	782	5	25	751	5			N/A
		66	1736	5	25	2156	5	7.2		IMD4
CA_2A-13A-66A-66B	CA_13A-66A	2	1880	5	25	1960	5	6.2	FDD	IMD4
		13	782	5	25	751	5			N/A
		66	1762	5	25	2162	5	N/A		N/A
CA_2A-48A-66A CA_2A-48C-66A	CA_48A-66A	2	1880	5	25	1960	5	28.3	FDD-TDD	IMD2
		48	3695	5	25	3695	5	N/A		N/A
		66	1735	5	25	2135	5	N/A		N/A
CA_2A-48A-66A CA_2A-48C-66A	CA_2A-48A	2	1905	5	25	1985	5	N/A	FDD-TDD	N/A
		48	3560	5	25	3560	5	N/A		N/A
		66	1755	5	25	2155	5	12.1		IMD4
CA_3A-5A-7A	CA_3A-5A	3	1780	10	50	1875	10	N/A	FDD	N/A
		5	845	5	25	890	5	N/A		N/A
		7	2505	10	50	2625	10	30.0		IMD2 <sup>1</sup>
	CA_3A-7A	3	1725	10	50	1820	10	N/A	FDD	N/A
		7	2565	10	50	2685	10	N/A		N/A
		5	840	5	25	885	5	19.0		IMD3
CA_3A-7A-8A	CA_3A-7A	3	1735	5	25	1830	5	N/A	FDD	N/A
		7	2530	10	50	2650	10			N/A
		8	895	5	25	940	5	18.0		IMD3
	CA_3A-8A	3	1780	5	25	1875	5	N/A	FDD	N/A
		8	890	5	25	935	5			N/A
		7	2550	10	50	2670	10	29.0		IMD2+1 MD3 <sup>4</sup>
CA_3A-7A-20A	CA_3A-7A	3	1737	5	25	1832	5	N/A	FDD	N/A
		7	2543	10	50	2663	10	N/A		N/A
		20	847	10	20	806	10	10.5		IMD2
	CA_3A-20A	3	1775	10	50	1870	10	N/A	FDD	N/A
		20	855	5	25	896	5	N/A		N/A
		7	2510	10	50	2630	10	26.0		IMD2 <sup>1</sup>
CA_3A-7A-26A	CA_3A-7A	3	1720	5	25	1815	5	N/A	FDD	N/A
		7	2560	10	50	2680	10	N/A		N/A
		26	835	5	25	880	5	17.5		IMD3

CA_3A-7A-26A	CA_3A-26A	3	1780	5	25	1875	5	N/A	FDD	N/A	
		26	845	5	25	890	5	N/A		N/A	
		7	2505	10	50	2625	10	29.0		IMD2 <sup>1</sup>	
CA_3A-7A-28A	CA_3A-7A	3	1747	5	25	1842	5	N/A	FDD	N/A	
		7	2543	5	25	2663	5	N/A		N/A	
		28	741	5	25	796.0	5	20.0		IMD2	
	CA_3A-28A	3	1712.5	5	25	1807.5	5	N/A	FDD	N/A	
		28	743	5	25	798	5	N/A		N/A	
		7	2562	5	25	2682	5	17.0		IMD3	
	CA_7A-28A	CA_7A-28A	7	2543	5	25	2663	5	N/A	FDD	N/A
			28	710.5	5	25	765.5	5	N/A		N/A
			3	1737.5	5	25	1832.5	5	26.0		IMD2
CA_3A-7A-32A	CA_3A-7A	3	1775	5	25	1870	5	N/A	FDD	N/A	
		7	2510	10	50	2630	10	N/A		N/A	
		32	-	-	-	1470	5	10.5		IMD4	
CA_3A-8A-38A	CA_3A-8A	3	1720	5	25	1815	5	N/A	FDD-TDD	N/A	
		8	890	5	25	935	5	N/A		N/A	
		38	2610	5	25	2610	5	26.4		IMD2	
	CA_3A-8A	CA_3A-8A	3	1750	5	25	1845	5	N/A	FDD-TDD	N/A
			8	900	5	25	945	5	N/A		N/A
			38	2600	5	25	2600	5	15.7		IMD3
CA_3A-11A-18A	CA_3A-11A	3	1725	5	25	1820	5	N/A	FDD	N/A	
		11	1440	5	25	1448	5	N/A		N/A	
		18	825	5	25	870	5	4.9		IMD5	
	CA_11A-18A	CA_11A-18A	11	1432	5	25	1481	5	N/A	FDD	N/A
			18	820	5	25	865	5	N/A		N/A
			3	1753	5	25	1848	5	4.0		IMD5
CA_3A-11A-26A	CA_3A-11A	3	1725	5	25	1820	5	N/A	FDD	N/A	
		11	1440	5	25	1448	5	N/A		N/A	
		26	825	5	25	870	5	4.9		IMD5	
	CA_3A-26A	CA_3A-26A	3	1782.5	5	25	1877.5	5	N/A	FDD	N/A
			26	816.5	5	25	861.5	5	N/A		N/A
			11	1435.5	5	25	1483.5	5	5.0		IMD5
	CA_11A-26A	CA_11A-26A	11	1440	5	25	1488	5	N/A	FDD	N/A
			26	824	5	25	869	5	N/A		N/A
			3	1761	5	25	1856	5	4.5		IMD5
CA_3A-19A-21A	CA_19A-21A	19	832.5	5	25	877.5	5	N/A	FDD	N/A	
		21	1460.4	5	25	1508.4	5	N/A		N/A	
		3	1774.6	5	25	1869.6	5	4.0		IMD5	
CA_3A-21A-28A	CA_3A-21A	3	1782	5	25	1877	5	N/A	FDD	N/A	
		21	1451	5	25	1499	5	N/A		N/A	
		28	734	5	25	789	5	3.0		IMD5	
CA_3A-28A-41A	CA_3A-41	3	1720	5	25	1815	5	N/A	FDD	N/A	
		41	2510	5	25	2510	5	N/A		TDD	
		28	735	5	25	790	5	26.0		FDD	
CA_3A-41A-42A	CA_41A-42A	41	2640	10	50	2640	10	N/A	TDD	N/A	
		42	3425	10	50	3425	10	N/A		N/A	
		3	1760	5	25	1855	5	16.0		FDD	

CA_5A-46D-66A	CA_5A_4 6D	5	834	5	25	879	5	N/A	FDD- TDD	N/A
		46	5491	20	100	5491	20			N/A
		66	1755	5	25	2155	5	0.3		IMD5
CA_13A-48A-66A	CA_13A- 48A	13	782	5	25	751	5	N/A	FDD- TDD	N/A
		48	3695	5	25	3695	5	N/A		N/A
		66	1731	5	25	2131	5	17.1		IMD3
CA_19A-21A-42A	CA_19A- 21A	19	842.5	5	25	887.5	5	N/A	FDD	N/A
		21	1450.4	5	25	1498.4	5	N/A	FDD	N/A
		42	3508.7	5	25	3508.7	5	13.0	TDD	IMD4
	CA_21A- 42A	21	1460.4	5	25	1508.4	5	N/A	FDD	N/A
		42	3500	5	25	3500	5	N/A	FDD	N/A
19	836.2	5	25	881.2	5	13.0	TDD	IMD4		
CA_28A-41A-42A	CA_41A- 42A	41	2672	10	50	2672	10	N/A	TDD	N/A
		42	3460	10	50	3460	10		TDD	N/A
		28	733	5	25	788	5	26.0	FDD	IMD2
CA_1A-21A-42A <sup>6</sup>	CA_1A- 42A	1							FDD	N/A
		42							TDD	N/A
		21							FDD	N/A
CA_2A-5A-48A CA_2A-5A-48C CA_2A-5A-48D		2	1882	5	25	1962	5	15.6	FDD- TDD	IMD3
		5	839	5	25	884	5	N/A		N/A
		48	3640	5	25	3640	5	N/A		N/A
CA_2A-5A-48C CA_2A-5A-48D	CA_5A- 48A	2	1905	5	25	1985	5	N/A	FDD- TDD	N/A
		5	844	5	25	889	5	N/A		N/A
		48	3593	5	25	3593	5	16.6		IMD3
CA_2A-13A-48A CA_2A-13A-48C CA_2A-13A-48D	CA_13A- 48A	2	1903.5	5	25	1983.5	5	15.6	FDD- TDD	IMD3
		13	784.5	5	25	753.5	5	N/A		N/A
		48	3552.5	5	25	3552.5	5	N/A		N/A
CA_2A-48A-66A, CA_2A-48D-66A, CA_2A-48E-66A, CA_2A-48A-66A-66A, CA_2A-48C-66A- 66A, CA_2A-48D-66A- 66A, CA_2A-48E-66A-66A	CA_2A- 66A	2	1855	5	25	1935	5	N/A	FDD- TDD	N/A
		48	3625	5	25	3625	5	32.0		IMD2
		66	1770	5	25	2190	5	N/A		N/A
CA_2A-14A-66A, CA_2A-2A-14A-66A, CA_2A-14A-66A-66A, CA_2A-2A-14A-66A- 66A, CA_2A-14A-66A- 66A-66A	CA_2A- 14A	2	1870	5	25	1950	5	N/A	FDD	N/A
		14	793	5	25	763	5	N/A		N/A
		66	1734	5	25	2154	5	7.2		IMD4
	CA_14A- 66A	2	1874	5	25	1954	5	6.2	FDD	IMD4
		14	793	5	25	763	5	N/A		N/A
		66	1770	5	25	2190	5	N/A		N/A

NOTE 1: This band is subject to IMD3 also which MSD is not specified.  
NOTE 1: Both of the transmitters shall be set min(+20 dBm, P<sub>CMAX,L,c</sub>) as defined in subclause 6.2.5A  
NOTE 2: RB<sub>START</sub> = 0  
NOTE 3: Void  
NOTE 4: This MSD requirement apply with both IMD2 and IMD3 products should be generated.  
NOTE 5: For operations with 4 antenna ports, the MSD in the applicable bands shall be modified by the absolute value of ΔR<sub>IB,4R</sub> in Table 7.3.1-1a when MSD > 0.  
NOTE 6: Due to the spectrum holdings of the operator, the deployed frequency ranges do not result MSD to interested downlink channel. Therefore, no requirements apply for this CA configuration.

For intra-band contiguous carrier aggregation the throughput of each component carrier shall be  $\geq 95\%$  of the maximum throughput of the reference measurement channels as specified in Annexes A.2.2, A.2.3 and A.3.2 (with one sided dynamic OCNG Pattern OP.1 FDD/TDD for the DL-signal as described in Annex A.5.1.1/A.5.2.1) with parameters specified in Table 7.3.1-1, Table 7.3.1-1a, Table 7.3.1-1A, Table 7.3.1-1B, Table 7.3.1-1C, Table 7.3.1A-0h and Table 7.3.1A-1. For operating bands with an unpaired DL part (as noted in Table 5.5-1), the power levels in Table 7.3.1-1 and Table 7.3.1-1a also apply for an SCC assigned in the unpaired part. The requirement is verified using an uplink CA

configuration with the largest number of carriers supported by the UE. Table 7.3.1A-0h, Table 7.3.1A-1 and Table 7.3.1A-2 specifies the maximum number of allocated uplink resource blocks for which the intra-band contiguous carrier aggregation reference sensitivity requirement shall be met. The PCC and SCC allocations as defined in Table 7.3.1A-0h, Table 7.3.1A-1 and Table 7.3.1A-2 form a contiguous allocation where TX–RX frequency separations of the component carriers are as defined in Table 5.7.4-1. In case downlink CA configuration has additional SCC(s) compared to uplink CA configuration those are configured further away from uplink band. For UE(s) supporting one uplink carrier, the uplink configuration of the PCC shall be in accordance with Table 7.3.1-2 and the downlink PCC carrier center frequency shall be configured closer to uplink operating band than any of the downlink SCC center frequency. Unless given by Table 7.3.1-3, the reference sensitivity requirements shall be verified with the network signalling value NS\_01 (Table 6.2.4-1) configured.

**Table 7.3.1A-0h: Intra-band contiguous CA uplink configuration for reference sensitivity for Bandwidth Class B**

Uplink CA configuration	CA configuration / CC combination / $N_{RB\_agg}$ / Duplex mode								Duplex Mode
	25RB+25RB		50RB+25RB		50RB+50RB		75RB+25RB		
	PCC	SCC	PCC	SCC	PCC	SCC	PCC	SCC	
CA_5B	N/A	N/A	25	0	25	0	N/A	N/A	FDD
CA_8B	N/A	N/A	25	0	25	0	N/A	N/A	FDD
CA_66B	25	25	50	25	50	50	75	25	FDD
NOTE 1: The carrier centre frequency of SCC in the UL operating band is configured closer to the DL operating band.									
NOTE 2: The transmitted power over both PCC and SCC shall be set to $P_{UMAX}$ as defined in subclause 6.2.5A.									
NOTE 3: The UL resource blocks in both PCC and SCC shall be confined within the transmission bandwidth configuration for the channel bandwidth (Table 5.6-1).									
NOTE 4: The UL resource blocks in PCC shall be located as close as possible to the downlink operating band, while the UL resource blocks in SCC shall be located as far as possible from the downlink operating band.									
NOTE 5: In case a CA configuration consists of CC channel bandwidths which are unequal in bandwidth the PCC channel bandwidth shall be the larger one for reference sensitivity test.									

**Table 7.3.1A-1: Intra-band contiguous CA uplink configuration for reference sensitivity for Bandwidth Class C**

Uplink CA configuration	CA configuration / CC combination / $N_{RB\_agg}$ / Duplex mode												Duplex Mode
	100RB+25RB		100RB+50RB		75RB+75RB		75RB+50RB		100RB+75RB		100RB+100RB		
	PCC	SCC	PCC	SCC	PCC	SCC	PCC	SCC	PCC	SCC	PCC	SCC	
CA_1C	N/A	N/A	N/A	N/A	75	54	N/A	N/A	N/A	N/A	100	30	FDD
CA_3C	50	0	50	0	N/A	N/A	N/A	N/A	50	0	50	0	FDD
CA_7C	N/A	N/A	75	0	75	0	75	0	75	0	75	0	FDD
CA_38C	N/A	N/A	N/A	N/A	75	75	N/A	N/A	N/A	N/A	100	100	TDD
CA_39C	100	25	100	50	N/A	N/A	N/A	N/A	100	75	N/A	N/A	TDD
CA_40C	N/A	N/A	100	50	75	75	N/A	N/A	100	75	100	100	TDD
CA_41C	100	25	100	50	75	75	75	50	100	75	100	100	TDD
CA_42C	100	25	100	50	N/A	N/A	N/A	N/A	100	75	100	100	TDD
CA_48C	100	25	100	50	N/A	N/A	N/A	N/A	100	75	100	100	TDD
CA_66C	100	25	100	50	75	75	75	50	100	75	100	100	FDD
NOTE 1: The carrier centre frequency of SCC in the UL operating band is configured closer to the DL operating band.													
NOTE 2: The transmitted power over both PCC and SCC shall be set to $P_{UMAX}$ as defined in subclause 6.2.5A.													
NOTE 3: The UL resource blocks in both PCC and SCC shall be confined within the transmission bandwidth configuration for the channel bandwidth (Table 5.6-1).													
NOTE 4: The UL resource blocks in PCC shall be located as close as possible to the downlink operating band, while the UL resource blocks in SCC shall be located as far as possible from the downlink operating band.													
NOTE 5: In case a CA configuration consists of CC channel bandwidths which are unequal in bandwidth the PCC channel bandwidth shall be the larger one for reference sensitivity test.													
NOTE 6: Void.													
NOTE 7: Void.													

**Table 7.3.1A-2: Intra-band contiguous CA uplink configuration for reference sensitivity for Bandwidth Class D**

CA configuration / CC combination / $N_{RB\_agg}$ / Duplex mode				
Uplink CA configuration	CC combination	Number of uplink resource blocks per CC		
		PCC	SCC	SCC
CA_40D	75RB+75RB+75RB 100RB+75RB+75RB 100RB+100RB+50RB 100RB+100RB+75RB 100RB+100RB+100RB	NOTE 6		
CA_41D	75RB+75RB+75RB 100RB+75RB+75RB 100RB+100RB+50RB 100RB+100RB+75RB 100RB+100RB+100RB	NOTE 6		
NOTE 1: The carrier centre frequency of SCC in the UL operating band is configured closer to the DL operating band. NOTE 2: The transmitted power over both PCC and SCC shall be set to PUMAX as defined in subclause 6.2.5A. NOTE 3: The UL resource blocks in both PCC and SCC shall be confined within the transmission bandwidth configuration for the channel bandwidth (Table 5.6-1). NOTE 4: The UL resource blocks in PCC shall be located as close as possible to the downlink operating band, while the UL resource blocks in SCC shall be located as far as possible from the downlink operating band. NOTE 5: In case a CA configuration consists of CC channel bandwidths which are unequal in bandwidth the PCC channel bandwidth shall be the larger one for reference sensitivity test. NOTE 6: All uplink CCs are fully allocated				

For intra-band non-contiguous carrier aggregation with one uplink carrier and two or more downlink sub-blocks, the throughput of each downlink component carrier shall be  $\geq 95\%$  of the maximum throughput of the reference measurement channels as specified in Annexes A.2.2, A.2.3 and A.3.2 (with one sided dynamic OCNG Pattern OP.1 FDD/TDD for the DL-signal as described in Annex A.5.1.1/A.5.2.1) and parameters specified in Table 7.3.1-1, Table 7.3.1-1a, Table 7.3.1-1A, Table 7.3.1-1B, Table 7.3.1-1C and Table 7.3.1A-3 with the reference sensitivity power level increased by  $\Delta R_{IBNC}$  given in Table 7.3.1A-3 for the SCC(s). For aggregation of more than two downlink FDD carriers with one uplink carrier the reference sensitivity is defined only for the specific uplink and downlink test points which are specified in Table 7.3.1A-3. The requirements apply with all downlink carriers active. Unless given by Table 7.3.1-3, the reference sensitivity requirements shall be verified with the network signalling value NS\_01 (Table 6.2.4-1) configured.

**Table 7.3.1A-3: Intra-band non-contiguous CA with one uplink configuration for reference sensitivity**



CA configuration	Aggregated channel bandwidth (PCC+SCC)	$W_{\text{gap}}$ / [MHz]	UL PCC allocation	$\Delta R_{\text{BNC}}$ (dB)	Duplex mode
CA_1A-1A	25RB + 25RB	$0.0 < W_{\text{gap}} \leq 50.0$	25 <sup>1</sup>	0.5	FDD
	25RB + 50RB	$0.0 < W_{\text{gap}} \leq 45.0$	25 <sup>1</sup>	0.5	
	25RB + 75RB	$0.0 < W_{\text{gap}} \leq 40.0$	25 <sup>1</sup>	0.5	
	25RB + 100RB	$0.0 < W_{\text{gap}} \leq 35.0$	25 <sup>1</sup>	0.5	
	50RB + 25RB	$0.0 < W_{\text{gap}} \leq 45.0$	50 <sup>1</sup>	0.5	
	50RB + 50RB	$0.0 < W_{\text{gap}} \leq 40.0$	50 <sup>1</sup>	0.5	
	50RB + 75RB	$0.0 < W_{\text{gap}} \leq 35.0$	50 <sup>1</sup>	0.5	
	50RB + 100RB	$0.0 < W_{\text{gap}} \leq 30.0$	50 <sup>1</sup>	0.5	
	75RB + 25RB	$0.0 < W_{\text{gap}} \leq 40.0$	75 <sup>1</sup>	0.5	
	75RB + 50RB	$0.0 < W_{\text{gap}} \leq 35.0$	75 <sup>1</sup>	0.5	
	75RB + 75RB	$0.0 < W_{\text{gap}} \leq 30.0$	75 <sup>1</sup>	0.5	
	75RB + 100RB	$0.0 < W_{\text{gap}} \leq 25.0$	75 <sup>1</sup>	0.5	
	100RB + 25RB	$20.0 < W_{\text{gap}} \leq 35.0$	90 <sup>1</sup>	0.5	
		$0.0 < W_{\text{gap}} \leq 20.0$	100 <sup>1</sup>	0.5	
	100RB + 50RB	$15.0 < W_{\text{gap}} \leq 30.0$	90 <sup>1</sup>	0.5	
		$0.0 < W_{\text{gap}} \leq 15.0$	100 <sup>1</sup>	0.5	
100RB + 75RB	$10.0 < W_{\text{gap}} \leq 25.0$	90 <sup>1</sup>	0.5		
	$0.0 < W_{\text{gap}} \leq 10.0$	100 <sup>1</sup>	0.5		
100RB + 100RB	$5.0 < W_{\text{gap}} \leq 20.0$	90 <sup>1</sup>	0.5		
	$0.0 < W_{\text{gap}} \leq 5.0$	100 <sup>1</sup>	0.5		
CA_2A-2A	25RB+25RB	$30.0 < W_{\text{gap}} \leq 50.0$	12 <sup>1</sup>	5.3	FDD
		$0.0 < W_{\text{gap}} \leq 30.0$	25 <sup>1</sup>	0	
	25RB+50RB	$25.0 < W_{\text{gap}} \leq 45.0$	12 <sup>1</sup>	4.4	
		$0.0 < W_{\text{gap}} \leq 25.0$	25 <sup>1</sup>	0	
	25RB+75RB	$20.0 < W_{\text{gap}} \leq 40.0$	12 <sup>1</sup>	4.2	
		$0.0 < W_{\text{gap}} \leq 20.0$	25 <sup>1</sup>	0	
	25RB+100RB	$15.0 < W_{\text{gap}} \leq 35.0$	12 <sup>1</sup>	3.8	
		$0.0 < W_{\text{gap}} \leq 15.0$	25 <sup>1</sup>	0	
	50RB+25RB	$15.0 < W_{\text{gap}} \leq 45.0$	12 <sup>1</sup>	5.9	
		$0.0 < W_{\text{gap}} \leq 15.0$	32 <sup>1</sup>	0	
	50RB+50RB	$10.0 < W_{\text{gap}} \leq 40.0$	12 <sup>1</sup>	4.6	
		$0.0 < W_{\text{gap}} \leq 10.0$	32 <sup>1</sup>	0	
	50RB+75RB	$5.0 < W_{\text{gap}} \leq 35.0$	12 <sup>1</sup>	4.1	
		$0.0 < W_{\text{gap}} \leq 5.0$	32 <sup>1</sup>	0	
	50RB+100RB	$0.0 < W_{\text{gap}} \leq 30.0$	12 <sup>1</sup>	4.0	
	75RB+25RB	$10.0 < W_{\text{gap}} \leq 40.0$	12 <sup>12</sup>	6.7	
$0.0 < W_{\text{gap}} \leq 10.0$		36 <sup>1</sup>	0		
75RB+50RB	$5.0 < W_{\text{gap}} \leq 35.0$	12 <sup>12</sup>	5.4		
	$0.0 < W_{\text{gap}} \leq 5.0$	36 <sup>1</sup>	0		
75RB+75RB	$0.0 < W_{\text{gap}} \leq 30.0$	12 <sup>12</sup>	4.6		
75RB+100RB	$0.0 < W_{\text{gap}} \leq 25.0$	12 <sup>12</sup>	4.2		
100RB+25RB	$0.0 < W_{\text{gap}} \leq 35.0$	16 <sup>13</sup>	7.2		
100RB+50RB	$0.0 < W_{\text{gap}} \leq 30.0$	16 <sup>13</sup>	5.8		
100RB+75RB	$0.0 < W_{\text{gap}} \leq 25.0$	16 <sup>13</sup>	5.0		
100RB+100RB	$0.0 < W_{\text{gap}} \leq 20.0$	16 <sup>13</sup>	4.6		
CA_3A-3A	15RB+25RB	$47.0 < W_{\text{gap}} \leq 67.0$	12 <sup>1</sup>	4.5	FDD
		$0.0 < W_{\text{gap}} \leq 47.0$	15 <sup>1</sup>	0	
	25RB+15RB	$47.0 < W_{\text{gap}} \leq 67.0$	12 <sup>1</sup>	4.9	
		$0.0 < W_{\text{gap}} \leq 47.0$	25 <sup>1</sup>	0	
	25RB+25RB	$45.0 < W_{\text{gap}} \leq 65.0$	12 <sup>1</sup>	4.7	
		$0.0 < W_{\text{gap}} \leq 45.0$	25 <sup>1</sup>	0	
25RB+50RB	$40.0 < W_{\text{gap}} \leq 60.0$	12 <sup>1</sup>	3.8		

		$0.0 < W_{\text{gap}} \leq 40.0$	$25^1$	0	
	25RB+75RB	$35.0 < W_{\text{gap}} \leq 55.0$	$12^1$	3.6	
		$0.0 < W_{\text{gap}} \leq 35.0$	$25^1$	0	
	25RB+100RB	$30.0 < W_{\text{gap}} \leq 50.0$	$12^1$	3.4	
		$0.0 < W_{\text{gap}} \leq 30.0$	$25^1$	0	
	50RB+25RB	$30.0 < W_{\text{gap}} \leq 60.0$	$12^9$	5.1	
		$0.0 < W_{\text{gap}} \leq 30.0$	$32^1$	0	
	50RB+50RB	$25.0 < W_{\text{gap}} \leq 55.0$	$12^9$	4.3	
		$0.0 < W_{\text{gap}} \leq 25.0$	$32^1$	0	
	50RB+75RB	$20.0 < W_{\text{gap}} \leq 50.0$	$12^9$	3.8	
		$0.0 < W_{\text{gap}} \leq 20.0$	$32^1$	0	
	50RB+100RB	$15.0 < W_{\text{gap}} \leq 45.0$	$12^9$	3.4	
		$0.0 < W_{\text{gap}} \leq 15.0$	$32^1$	0	
	75RB+25RB	$25.0 < W_{\text{gap}} \leq 55.0$	$12^{10}$	6.0	
		$0.0 < W_{\text{gap}} \leq 25.0$	$32^1$	0	
	75RB+50RB	$20.0 < W_{\text{gap}} \leq 50.0$	$12^{10}$	4.7	
		$0.0 < W_{\text{gap}} \leq 20.0$	$32^1$	0	
	75RB+75RB	$15.0 < W_{\text{gap}} \leq 45.0$	$12^{10}$	4.2	
		$0.0 < W_{\text{gap}} \leq 15.0$	$32^1$	0	
	75RB+100RB	$10.0 < W_{\text{gap}} \leq 40.0$	$12^{10}$	3.8	
		$0.0 < W_{\text{gap}} \leq 10.0$	$32^1$	0	
	100RB+25RB	$15.0 < W_{\text{gap}} \leq 50.0$	$16^{11}$	6.5	
		$0.0 < W_{\text{gap}} \leq 15.0$	$32^1$	0	
	100RB+50RB	$10.0 < W_{\text{gap}} \leq 45.0$	$16^{11}$	5.1	
		$0.0 < W_{\text{gap}} \leq 10.0$	$32^1$	0	
	100RB+75RB	$5.0 < W_{\text{gap}} \leq 40.0$	$16^{11}$	4.5	
		$0.0 < W_{\text{gap}} \leq 5.0$	$32^1$	0	
	100RB+100RB	$0.0 < W_{\text{gap}} \leq 35.0$	$16^{11}$	4.1	
CA_4A-4A	NOTE 6	NOTE 7	NOTE 8	0.0	FDD
	25RB+25RB	NOTE 7	$12^1$	5.3	
CA_5A-5A	25RB+50RB	NOTE 7	$12^1$	4.4	FDD
	50RB+25RB	NOTE 7	$12^1$	5.9	
	50RB+50RB	NOTE 7	$12^1$	4.6	
	25RB+25RB	$0 < W_{\text{gap}} \leq 60$	25	0.0	
	25RB+50RB	$0 < W_{\text{gap}} \leq 55$	25	0.0	
	25RB+75RB	$0 < W_{\text{gap}} \leq 50$	25	0.0	
	25RB+100RB	$0 < W_{\text{gap}} \leq 45$	25	0.0	
	50RB+25RB	$30 < W_{\text{gap}} \leq 55$	$32^1$	0.0	
		$0 < W_{\text{gap}} \leq 30$	50	0.0	
	50RB+50RB	$25.0 < W_{\text{gap}} \leq 50.0$	$32^1$	0.0	
		$0.0 < W_{\text{gap}} \leq 25.0$	50	0.0	
	50RB+75RB	$20 < W_{\text{gap}} \leq 45$	$32^1$	0.0	
		$0 < W_{\text{gap}} \leq 20$	50	0.0	
CA_7A-7A	50RB+100RB	$15 < W_{\text{gap}} \leq 40$	$32^1$	0.0	FDD
		$0 < W_{\text{gap}} \leq 15$	50	0.0	
	75RB+25RB	$20.0 < W_{\text{gap}} \leq 50.0$	$32^1$	0.0	
		$0.0 < W_{\text{gap}} \leq 20.0$	$50^1$	0.0	
	75RB+50RB	$20.0 < W_{\text{gap}} \leq 45.0$	$32^1$	0.0	
		$0.0 < W_{\text{gap}} \leq 20.0$	$50^1$	0.0	
	75RB+75RB	$15.0 < W_{\text{gap}} \leq 40.0$	$32^1$	0.0	
		$0.0 < W_{\text{gap}} \leq 15.0$	$50^1$	0.0	
	75RB+100RB	$10 < W_{\text{gap}} \leq 35$	$32^1$	0.0	
		$0 < W_{\text{gap}} \leq 10$	$50^1$	0.0	
	100RB+25RB	$25 < W_{\text{gap}} \leq 45$	$32^1$	0.0	

	100RB+50RB	$0 < W_{gap} \leq 25$	$45^1$	0.0	
		$20 < W_{gap} \leq 40$	$32^1$	0.0	
	100RB+75RB	$0 < W_{gap} \leq 20$	$45^1$	0.0	
		$15.0 < W_{gap} \leq 35.0$	$36^1$	0.0	
	100RB+100RB	$0.0 < W_{gap} \leq 15.0$	$50^1$	0.0	
		$15.0 < W_{gap} \leq 30.0$	$32^1$	0.0	
CA_12A-12A	25RB+25RB	$0.0 < W_{gap} \leq 7.0$	$5^{18}$	3	FDD
CA_23A-23A	NOTE 6	NOTE 7	NOTE 8	0.0	FDD
CA_25A-25A	25RB+25RB	$30.0 < W_{gap} \leq 55.0$	$10^1$	5.0	FDD
		$0.0 < W_{gap} \leq 30.0$	$25^1$	0.0	
	25RB+50RB	$25.0 < W_{gap} \leq 50.0$	$10^1$	4.5	
		$0.0 < W_{gap} \leq 25.0$	$25^1$	0.0	
	25RB+75RB	$20 < W_{gap} \leq 45$	$10^1$	4.3	
		$0 < W_{gap} \leq 20$	$25^1$	0	
	25RB+100RB	$15 < W_{gap} \leq 40$	$10^1$	4.1	
		$0 < W_{gap} \leq 15$	$25^1$	0	
	50RB+25RB	$15.0 < W_{gap} \leq 50.0$	$10^4$	5.5	
		$0.0 < W_{gap} \leq 15.0$	$32^1$	0.0	
	50RB+50RB	$10.0 < W_{gap} \leq 45.0$	$10^4$	5.0	
		$0.0 < W_{gap} \leq 10.0$	$32^1$	0.0	
	50RB+75RB	$5 < W_{gap} \leq 40$	$10^4$	4.5	
		$0 < W_{gap} \leq 5$	$32^1$	0	
	50RB+100RB	$0 < W_{gap} \leq 35$	$10^4$	4.2	
		$10 < W_{gap} \leq 45$	$10^{14}$	7.6	
	75RB+25RB	$0 < W_{gap} \leq 10$	$32^1$	0	
		$5 < W_{gap} \leq 40$	$10^{14}$	6.7	
	75RB+50RB	$0 < W_{gap} \leq 5$	$32^1$	0	
		$0 < W_{gap} \leq 35$	$10^{14}$	5.6	
75RB+75RB	$0 < W_{gap} \leq 30$	$10^{14}$	4.8		
	$0 < W_{gap} \leq 40$	$12^{15}$	8		
100RB+25RB	$0 < W_{gap} \leq 35$	$12^{15}$	6.7		
	$0 < W_{gap} \leq 30$	$12^{15}$	6.1		
100RB+50RB	$0 < W_{gap} \leq 30$	$12^{15}$	6.1		
	$0 < W_{gap} \leq 25$	$12^{15}$	5.7		
CA_25A-25A-25A	25RB+25RB+25RB	$W_{gap\_L} = W_{gap\_H} = 25$ MHz	$10^1$	5.0	FDD
		$W_{gap\_L} = W_{gap\_H} = 5$ MHz	$25^1$	0.0	
	50RB+50RB+50RB	$W_{gap\_L} = W_{gap\_H} = 17.5$ MHz	$10^4$	5.0	
	75RB+75RB+75RB	$W_{gap\_L} = W_{gap\_H} = 10$ MHz	$10^{14}$	5.6	
100RB+100RB+100RB	$W_{gap\_L} = W_{gap\_H} = 2.5$ MHz	$12^{15}$	5.7		
CA_40A-40A	NOTE 6	NOTE 7	NOTE 8	0.0	TDD
CA_40A-40C	NOTE 6	NOTE 7	NOTE 8	0.0	TDD
CA_40C-40C	NOTE 6	NOTE 7	NOTE 8	0.0	TDD
CA_41A-41A	NOTE 6	NOTE 7	NOTE 8	0.0	TDD
CA_41A-41C	NOTE 6	NOTE 7	NOTE 8	0.0	TDD
CA_41A-41D	NOTE 6	NOTE 7	NOTE 8	0.0	TDD
CA_41C-41C	NOTE 6	NOTE 7	NOTE 8	0.0	TDD
CA_41A-41A-41A	NOTE 6	NOTE 7	NOTE 8	0.0	TDD
CA_41A-41A-41C	NOTE 6	NOTE 7	NOTE 8	0.0	TDD
CA_42A-42A	NOTE 6	NOTE 7	NOTE 8	0.0	TDD
CA_42A-42C	NOTE 6	NOTE 7	NOTE 8	0.0	TDD
CA_42A-42D	NOTE 6	NOTE 7	NOTE 8	0.0	TDD
CA_42C-42C	NOTE 6	NOTE 7	NOTE 8	0.0	TDD
CA_48A-48A	NOTE 6	NOTE 7	NOTE 8	0.0	TDD
CA_48A-48A-48A	NOTE 6	NOTE 7	NOTE 8	0.0	TDD
CA_48A-48A-48A-48A	NOTE 6	NOTE 7	NOTE 8	0.0	TDD
CA_48A-48C	NOTE 6	NOTE 7	NOTE 8	0.0	TDD

CA_48A-48D	NOTE 6	NOTE 7	NOTE 8	0.0	TDD
CA_48A-48E	NOTE 6	NOTE 7	NOTE 8	0.0	TDD
CA_48C-48C	NOTE 6	NOTE 7	NOTE 8	0.0	TDD
CA_48C-48D	NOTE 6	NOTE 7	NOTE 8	0.0	TDD
CA_66A-66A	NOTE 6	NOTE 7	NOTE 8, NOTE 16	0.0	FDD
CA_66A-66A- 66A	NOTE 6	NOTE 7	NOTE 8, NOTE 16	0.0	FDD
CA_66A-66B	NOTE 6	NOTE 7	NOTE 8, NOTE 16	0.0	FDD
CA_66A-66C	NOTE 6	NOTE 7	NOTE 8, NOTE 16	0.0	FDD

NOTE 1: <sup>1</sup> refers to the UL resource blocks shall be located as close as possible to the downlink operating band but confined within the transmission.

NOTE 2:  $W_{\text{gap}}$  is the sub-block gap between the two sub-blocks.

NOTE 3: The carrier center frequency of PCC in the UL operating band is configured closer to the DL operating band.

NOTE 4: <sup>4</sup> refers to the UL resource blocks shall be located at  $RB_{\text{start}}=33$ .

NOTE 5: For the TDD intra-band non-contiguous CA configurations, the minimum requirements apply only in synchronized operation between all component carriers.

NOTE 6: All combinations of channel bandwidths defined in Table 5.6A.1-3.

NOTE 7: All applicable sub-block gap sizes.

NOTE 8: The PCC allocation is same as Transmission bandwidth configuration  $N_{\text{RB}}$  as defined in Table 5.6-1. In case of uplink sub-block is TDD intra-band contiguous CA then the uplink PCC and SCC allocations are the same as  $N_{\text{RB,agg}}$  defined in Table 7.3.1A-1.

NOTE 9: <sup>9</sup> refers to the UL resource blocks shall be located at  $RB_{\text{start}}=25$ .

NOTE 10: <sup>10</sup> refers to the UL resource blocks shall be located at  $RB_{\text{start}}=35$ .

NOTE 11: <sup>11</sup> refers to the UL resource blocks shall be located at  $RB_{\text{start}}=50$ .

NOTE 12: <sup>12</sup> refers to the UL resource blocks shall be located at  $RB_{\text{start}}=39$ .

NOTE 13: <sup>13</sup> refers to the UL resource blocks shall be located at  $RB_{\text{start}}=57$ .

NOTE 14: <sup>14</sup> refers to the UL resource blocks shall be located at  $RB_{\text{start}}=44$ .

NOTE 15: <sup>15</sup> refers to the UL resource blocks shall be located at  $RB_{\text{start}}=62$ .

NOTE 16: The carrier center frequency of PCC in the DL operating band is configured closer to the UL operating band.

NOTE 17: Void

NOTE 18: <sup>18</sup> refers to the UL resource blocks shall be located at  $RB_{\text{start}}=12$ .

NOTE 19: For operations with 4 antenna ports, the MSD in the applicable bands shall be modified by the absolute value of  $\Delta R_{\text{RB,4R}}$  in Table 7.3.1-1a when  $\text{MSD} > 0$ .

For intra-band non-contiguous carrier aggregation with two uplink and downlink carriers the reference sensitivity is defined to be met with both downlink and uplink carriers activated. The downlink PCC and SCC minimum requirements for reference sensitivity power level as specified in Table 7.3.1-1, Table 7.3.1-1a, Table 7.3.1-1A, Table 7.3.1-1B and Table 7.3.1-1C are increased by amount of  $\Delta R_{2\text{UL,PCC}}$  and  $\Delta R_{2\text{UL,SCC}}$  which are defined in Table 7.3.1A-4 when uplink PCC and SCC allocations are according to the Table 7.3.1A-4.

**Table 7.3.1A-4: Intra-band non-contiguous CA with two uplinks configuration for reference sensitivity**

CA configuration	Aggregated channel bandwidth (PCC+SCC)	$W_{\text{gap}}$ / [MHz]	UL PCC allocation	UL SCC allocation	$\Delta R_{2\text{UL,PCC}}$ (dB)	$\Delta R_{2\text{UL,SCC}}$ (dB)	Duplex mode
CA_4A-4A	NOTE 2	NOTE 3	NOTE 4	NOTE 5	0.0	0.0	FDD

NOTE 1: The transmitter shall be set to  $P_{\text{UMAX}}$  as defined in subclause 6.2.5A.

NOTE 2: All combinations of channel bandwidths defined in Table 5.6A.1-3.

NOTE 3: All applicable sub-block gap sizes.

NOTE 4: The PCC allocation is same as Transmission bandwidth configuration  $N_{\text{RB}}$  as defined in Table 5.6-1.

NOTE 5: The SCC allocation is same as Transmission bandwidth configuration  $N_{\text{RB}}$  as defined in Table 5.6-1.

For combinations of intra-band and inter-band carrier aggregation, the requirement is defined with an uplink configuration in accordance with Table 7.3.1A-3 when the uplink is active in the band supporting two or more non-contiguous component carriers, Table 7.3.1A-1 when the uplink (up to two contiguously aggregated uplink carriers) is active in a band supporting two contiguous component carriers and in accordance with Table 7.3.1-2 when an uplink is active in a band supporting one carrier per band. The downlink PCC shall be configured closer to the uplink operating band than the downlink SCC(s) when the uplink is active in band(s) supporting contiguous aggregation. The carrier

center frequency of PCC in the UL operating band is configured closer to the DL operating band when the uplink is active in band(s) supporting non-contiguous aggregation. For these uplink configurations, the UE shall meet the reference sensitivity requirements for intra-band non-contiguous carrier aggregation of two or more downlink sub-blocks, the requirements for intra-band contiguous carrier aggregation for the contiguously aggregated downlink carriers and for any remaining component carrier(s) the requirements specified in subclause 7.3.1. For the two or more component carriers within the same band,  $\Delta R_{\text{BNC}} = 0$  dB for all sub-block gaps (Table 7.3.1A-3) when the uplink is active in another band. All downlink carriers shall be active throughout the tests and the requirements for the downlinks shall be met with all uplink carriers active in each band capable of UL operation. For component carriers configured in Band 46, the said requirements for intra-band carrier aggregation of downlink carriers are replaced by the requirements in Table 7.3.1A-0eA for the uplink in any band other than band 46 with the uplink configuration specified in Table 7.3.1-2. Unless given by Table 7.3.1-3, the reference sensitivity requirements shall be verified with the network signalling value NS\_01 (Table 6.2.4-1) configured.

For the UE that supports any of combinations of intra-band and inter-band carrier aggregation given in Table 7.3.1A-5, exceptions to the requirements for a band(s) specified in subclause 7.3.1 are allowed when the band(s) is impacted by harmonic interference from the uplink being active in a lower-frequency band of the same CA configuration. For these exceptions, the UE shall meet the requirements specified in Table 7.3.1A-5 and Table 7.3.1A-6.

**Table 7.3.1A-5: Reference sensitivity for carrier aggregation QPSK  $P_{\text{REFSENS, CA}}$  (exceptions due to harmonic issues in the combinations of intra-band and inter-band CA)**

Channel bandwidth								
EUTRA CA Configuration	EUTRA band	1.4 MHz (dBm)	3 MHz (dBm)	5 MHz (dBm)	10 MHz (dBm)	15 MHz (dBm)	20 MHz (dBm)	Duplex mode
CA_1A-3A-3A-7A-8A <sup>4</sup> CA_1A-3A-7A-7A-8A <sup>4</sup> CA_1A-3A-3A-7A-7A-8A <sup>4</sup>	3			N/A	N/A	N/A	N/A	FDD
CA_1A-3A-3A-7A-8A <sup>5,6</sup> CA_1A-3A-7A-7A-8A <sup>5,6</sup> CA_1A-3A-3A-7A-7A-8A <sup>5,6</sup>	7 <sup>33</sup>			-88	-87.4	-87	-86.7	FDD
CA_1A-1A-3A-7A-28A <sup>5,6</sup> CA_1A-1A-3A-7C-28A <sup>5,6</sup> CA_1A-1A-3C-7A-28A <sup>5,6</sup> CA_1A-1A-3C-7C-28A <sup>5,6</sup> CA_1A-1A-3A-3A-7A-28A <sup>5,6</sup> CA_1A-1A-3A-3A-7C-28A <sup>5,6</sup> CA_1A-3A-7C-28A <sup>5,6</sup> CA_1A-3C-7A-28A <sup>5,6</sup> CA_1A-3C-7C-28A <sup>5,6</sup> CA_1A-3A-3A-7A-28A <sup>5,6</sup> CA_1A-3A-3A-7C-28A <sup>5,6</sup> CA_1A-3A-7A-7A-28A <sup>5,6</sup>	1 <sup>21</sup>			-89.8	-89.4	-89	-88.7	FDD
CA_1A-3C-8A <sup>4</sup>	3			N/A	N/A	N/A	N/A	FDD
CA_1A-3A-8A-42C <sup>4</sup>	3			N/A	N/A	N/A	N/A	FDD
CA_1A-3A-8A-42C <sup>8,9</sup>	42 <sup>21</sup>			-71.7	-71.7	-71.7	-71.7	TDD
CA_1A-3A-8A-42C <sup>10</sup>	42 <sup>21</sup>			-97.1	-94.7	-93.2	-92.5	TDD
CA_1A-3A-8A-42C <sup>15,16</sup>	42 <sup>21</sup>			-84.8	-84.7	-84.6	-84.5	TDD
CA_1A-3A-18A-42C <sup>8,9</sup>	42 <sup>21</sup>			-71.7	-71.7	-71.7	-71.7	TDD
CA_1A-3A-18A-42C <sup>10</sup>	42 <sup>21</sup>			-97.1	-94.7	-93.2	-92.5	TDD
CA_1A-3A-19A-42C <sup>8,9</sup>	42 <sup>21</sup>			-71.7	-71.7	-71.7	-71.7	TDD
CA_1A-3A-19A-42C <sup>10</sup>	42 <sup>21</sup>			-97.1	-94.7	-93.2	-92.5	TDD
CA_1A-3A-3A-20A-28A	1 <sup>21</sup>			-89.8	-89.4	-89	-88.7	FDD
CA_1A-3A-21A-42C <sup>8,9</sup>	42 <sup>21</sup>			-71.7	-71.7	-71.7	-71.7	TDD
CA_1A-3A-21A-42C <sup>10</sup>	42 <sup>21</sup>			-97.1	-94.7	-93.2	-92.5	TDD
CA_1A-3C-28A	1 <sup>21</sup>			-89.8	-89.4	-89	-88.7	FDD
CA_1A-3A-28A-40C <sup>16,17</sup>	28			-60.7	-60.7	-60.7	-60.7	FDD
CA_1A-3A-28A-42C <sup>8,9</sup>	42 <sup>21</sup>			-71.7	-71.7	-71.7	-71.7	TDD
CA_1A-3A-28A-42C <sup>10</sup>	42 <sup>21</sup>			-97.1	-94.7	-93.2	-92.5	TDD
CA_1A-3A-41A-42C <sup>8,9</sup> CA_1A-3A-41C-42A <sup>8,9</sup> CA_1A-3A-41C-42C <sup>8,9</sup>	42 <sup>21</sup>			-71.7	-71.7	-71.7	-71.7	TDD
CA_1A-3A-41A-42C <sup>10</sup> CA_1A-3A-41C-42A <sup>10</sup> CA_1A-3A-41C-42C <sup>10</sup>	42 <sup>21</sup>			-97.1	-94.7	-93.2	-92.5	TDD
CA_1A-3A-42C <sup>8,9</sup>	42 <sup>21</sup>			-71.7	-71.7	-71.7	-71.7	TDD

CA_1A-3A-42D <sup>8,9</sup>	42 <sup>21</sup>			-71.7	-71.7	-71.7	-71.7	TDD
CA_1A-7A-8A-40C <sup>5,6</sup>	7 <sup>33</sup>				-87.1	-86.7	-86.4	FDD
CA_1A-7C-28A <sup>5,6</sup>	1 <sup>21</sup>			-89.8	-89.4	-89	-88.7	FDD
CA_1A-7A-28A-40C <sup>16,17</sup>	28			-60.7	-60.7	-60.7	-60.7	FDD
CA_1A-8A-11A-42C <sup>15,16</sup>	42 <sup>21</sup>			-84.8	-84.7	-84.6	-84.5	TDD
CA_1A-3A-42C <sup>10</sup>	42 <sup>21</sup>			-97.1	-94.7	-93.2	-92.5	TDD
CA_1A-3A-42D <sup>10</sup>	42 <sup>21</sup>			-97.1	-94.7	-93.2	-92.5	TDD
CA_1A-3A-3A-42C <sup>9,10</sup>	42 <sup>21</sup>			-97.1	-94.7	-93.2	-92.5	TDD
CA_1A-3A-3A-42C <sup>11</sup>	42 <sup>21</sup>			-97.1	-94.7	-93.2	-92.5	TDD
CA_1A-21A-28A-42C <sup>4,14</sup>	21			N/A	N/A	N/A		FDD
	42			N/A	N/A	N/A	N/A	TDD
CA_1A-28A-42C <sup>5,6,12,13</sup>	1 <sup>21</sup>			-89.8	-89.4	-89	-88.7	FDD
	42			-85.7	-85.4	-85.1	-84.9	TDD
CA_2A-2A-4A-12A <sup>5,6</sup>	4 <sup>21</sup>			-90	-89.5	-89	-88.5	FDD
CA_2A-2A-5A-12A-66A <sup>5,6</sup>	66 <sup>21</sup>			-89.5	-89	-88.5	-88	FDD
CA_2A-2A-7A-12A-66A <sup>5,6</sup>	66 <sup>21</sup>			-89.5	-89	-88.5	-88	FDD
CA_2A-2A-12A-66A-66A <sup>5,6</sup>	66 <sup>21</sup>			-89.5	-89	-88.5	-88	FDD
CA_2A-13A-48A-48A <sup>8,9</sup>	48			-71.7	-71.7	-71.7	-71.7	TDD
CA_2A-13A-48C <sup>8,9</sup>								
CA_2A-13A-48A-48A <sup>10</sup>	48			-97.1	-94.7	-93.2	-92.5	TDD
CA_2A-13A-48C <sup>10</sup>								
CA_2A-7A-12B-66A <sup>5,6</sup>	66 <sup>21</sup>			-89.5	-89	-88.5	-88	FDD
CA_2A-2A-12A-30A-66A <sup>5,6</sup>	66 <sup>21</sup>			-89.5	-89	-88.5	-88	FDD
CA_2A-2A-12A-66A <sup>5,6</sup>	66 <sup>21</sup>			-89.5	-89	-88.5	-88	FDD
CA_2A-2A-12B-66A <sup>5,6</sup>	66 <sup>21</sup>			-89.5	-89	-88.5	-88	FDD
CA_2A-12A-30A-66A-66A <sup>5,6</sup>	66 <sup>21</sup>			-89.5	-89	-88.5	-88	FDD
CA_2A-12B-66A <sup>5,6</sup>	16 <sup>21</sup>			-89.5	-89	-88.5	-88	FDD
CA_2A-12B-66A-66A <sup>5,6</sup>	66 <sup>21</sup>			-89.5	-89	-88.5	-88	FDD
CA_2A-4A-4A-12A <sup>5,6</sup>	4 <sup>21</sup>			-90	-89.5	-89	-88.5	FDD
CA_2A-4A-12A-12A <sup>5,6</sup>	4 <sup>21</sup>			-90	-89.5	-89	-88.5	FDD
CA_2A-4A-12B <sup>5,6</sup>	4 <sup>21</sup>			-90	-89.5	-89	-88.5	FDD
CA_2A-48A-48C <sup>9,22</sup>	48			-71.7	-71.7	-71.7	-71.7	TDD
CA_2A-48A-48C <sup>1</sup>	48			-97.1	-94.7	-93.2	-92.5	TDD
CA_2A-48A-48D <sup>8,9</sup>	48			-71.7	-71.7	-71.7	-71.7	TDD
CA_2A-48A-48D <sup>10</sup>	48			-97.1	-94.7	-93.2	-92.5	TDD
CA_2A-48C-48C <sup>8,9</sup>	48			-71.7	-71.7	-71.7	-71.7	TDD
CA_2A-48C-48C <sup>10</sup>	48			-97.1	-94.7	-93.2	-92.5	TDD
CA_2A-48D <sup>9,22</sup>	48			-71.7	-71.7	-71.7	-71.7	TDD
CA_2A-48D <sup>10</sup>	48			-97.1	-94.7	-93.2	-92.5	TDD
CA_2A-48E <sup>8,9</sup>	48			-71.7	-71.7	-71.7	-71.7	TDD
CA_2A-48E <sup>10</sup>	48			-97.1	-94.7	-93.2	-92.5	TDD
CA_2A-12A-66A-66A <sup>5,6</sup>	66 <sup>21</sup>			-89.5	-89	-88.5	-88	FDD
CA_2A-12A-66C <sup>5,6</sup>	66 <sup>21</sup>			-89.5	-89	-88.5	-88	FDD
CA_2A-13A-48D <sup>8,9</sup>	48			-71.7	-71.7	-71.7	-71.7	TDD
CA_2A-13A-48D <sup>10</sup>	48			-97.1	-94.7	-93.2	-92.5	TDD
CA_2A-13A-48A-48C <sup>8,9</sup>	48			-71.7	-71.7	-71.7	-71.7	TDD
CA_2A-13A-48A-48C <sup>10</sup>	48			-97.1	-94.7	-93.2	-92.5	TDD



CA_2A-13A-48C-66A <sup>8,9</sup>	48			-71.7	-71.7	-71.7	-71.7	TDD
CA_2A-13A-48C-66A <sup>10</sup>	48			-97.1	-94.7	-93.2	-92.5	TDD
CA_2A-13A-48A-48A-66A <sup>8,9</sup>	48			-71.7	-71.7	-71.7	-71.7	TDD
CA_2A-13A-48A-48A-66A <sup>10</sup>	48			-97.1	-94.7	-93.2	-92.5	TDD
CA_2A-48D-66A <sup>8,9</sup>	48			-71.7	-71.7	-71.7	-71.7	TDD
CA_2A-48D-66A <sup>10</sup>	48			-97.1	-94.7	-93.2	-92.5	TDD
CA_2A-48E-66A <sup>8,9</sup>	48			-71.7	-71.7	-71.7	-71.7	TDD
CA_2A-48E-66A <sup>10</sup>	48			-97.1	-94.7	-93.2	-92.5	TDD
CA_2A-48A-48A-66A <sup>8,9</sup>	48			-71.7	-71.7	-71.7	-71.7	TDD
CA_2A-48A-48A-66A <sup>10</sup>	48			-97.1	-94.7	-93.2	-92.5	TDD
CA_2A-48A-48C-66A <sup>8,9</sup>	48			-71.7	-71.7	-71.7	-71.7	TDD
CA_2A-48A-48C-66A <sup>10</sup>	48			-97.1	-94.7	-93.2	-92.5	TDD
CA_3A-3A-7A-7A-8A <sup>4</sup>	3			N/A	N/A	N/A	N/A	
CA_3A-3A-7A-7A-8A <sup>5,6</sup>	7 <sup>21</sup>			-88	-87.4	-87	-86.7	FDD
CA_3A-3A-7A-8A <sup>4</sup>	3			N/A	N/A	N/A	N/A	FDD
CA_3A-3A-7A-8A <sup>5,6</sup>	7 <sup>21</sup>			-88	-87.4	-87	-86.7	FDD
CA_3A-3A-8A <sup>4</sup>	3			N/A	N/A	N/A	N/A	FDD
CA_3A-7A-7A-8A <sup>4</sup>	3			N/A	N/A	N/A	N/A	FDD
	7			N/A	N/A	N/A	N/A	
CA_3A-7A-7A-8A <sup>4,5,6</sup>	3			-97	-94	-92.2	-91	FDD
	7 <sup>21</sup>			-88	-87.4	-87	-86.7	
CA_3C-7A-8A-38A <sup>4</sup>	3			N/A	N/A	N/A	N/A	FDD
	7			N/A	N/A	N/A	N/A	
CA_3A-7A-8A-40C <sup>4</sup>	3			N/A	N/A	N/A	N/A	FDD
	7				N/A	N/A	N/A	
CA_3A-7A-8A-40C <sup>5,6</sup>	7 <sup>33</sup>				-87.1	-86.7	-86.4	FDD
CA_3A-7A-28A-40C <sup>16,17</sup>	28			-60.7	-60.7	-60.7	-60.7	FDD
CA_3A-19A-42C <sup>8,9</sup>	42 <sup>21</sup>			-71.7	-71.7	-71.7	-71.7	TDD
CA_3A-19A-42C <sup>10</sup>	42 <sup>21</sup>			-97.1	-94.7	-93.2	-92.5	
CA_3A-19A-42D <sup>8,9</sup>	42 <sup>21</sup>			-71.7	-71.7	-71.7	-71.7	TDD
CA_3A-19A-42D <sup>10</sup>	42 <sup>21</sup>			-97.1	-94.7	-93.2	-92.5	TDD
CA_3A-21A-42C <sup>1,2</sup>	42 <sup>21</sup>			-71.7	-71.7	-71.7	-71.7	TDD
CA_3A-21A-42C <sup>3</sup>	42 <sup>21</sup>			-97.1	-94.7	-93.2	-92.5	TDD
CA_3A-21A-42D <sup>8,9</sup>	42 <sup>21</sup>			-71.7	-71.7	-71.7	-71.7	TDD
CA_3A-21A-42D <sup>10</sup>	42 <sup>21</sup>			-97.1	-94.7	-93.2	-92.5	TDD
CA_3A-28A-40C <sup>8,9</sup>	28			-60.7	-60.7	-60.7	-60.7	FDD
CA_3A-28A-40D <sup>8,9</sup>	28			-60.7	-60.7	-60.7	-60.7	FDD
CA_3A-28A-41A-42C <sup>8,9,20</sup>	42 <sup>21</sup>				-71.7	-71.7	-71.7	TDD
CA_3A-28A-41A-42C <sup>10,20</sup>	42 <sup>21</sup>				-94.7	-93.2	-92.5	TDD
CA_3A-28A-41A-42C <sup>12,13,20</sup>	42 <sup>21</sup>				-85.4	-85.1	-84.9	TDD
CA_3A-28A-41C-42A <sup>8,9,20</sup>	42 <sup>21</sup>				-71.7	-71.7	-71.7	TDD
CA_3A-28A-41C-42A <sup>10,20</sup>	42 <sup>21</sup>				-94.7	-93.2	-92.5	TDD
CA_3A-28A-41C-42A <sup>12,13,20</sup>	42 <sup>21</sup>				-85.4	-85.1	-84.9	TDD
CA_3A-28A-41C-42C <sup>8,9,20</sup>	42 <sup>21</sup>				-71.7	-71.7	-71.7	TDD

CA_3A-28A-41C-42C <sup>10,20</sup>	42 <sup>21</sup>				-94.7	-93.2	-92.5	TDD
CA_3A-28A-41C-42C <sup>12,13,20</sup>	42 <sup>21</sup>				-85.4	-85.1	-84.9	TDD
CA_3A-28A-42C <sup>8,9</sup>	42 <sup>21</sup>			-71.7	-71.7	-71.7	-71.7	TDD
CA_3A-28A-42C <sup>10</sup>	42 <sup>21</sup>			-97.1	-94.7	-93.2	-92.5	TDD
CA_3A-28A-42C <sup>12,13</sup>	42 <sup>21</sup>			-85.7	-85.4	-85.1	-84.9	TDD
CA_3A-28A-42D <sup>8,9</sup>	42 <sup>21</sup>			-71.7	-71.7	-71.7	-71.7	TDD
CA_3A-28A-42D <sup>10</sup>	42 <sup>21</sup>			-97.1	-94.7	-93.2	-92.5	TDD
CA_3A-28A-42D <sup>12,13</sup>	42 <sup>21</sup>			-85.7	-85.4	-85.1	-84.9	TDD
CA_3A-28A-42A-42A <sup>8,9</sup>	42 <sup>21</sup>			-71.7	-71.7	-71.7	-71.7	TDD
CA_3A-28A-42A-42A <sup>10</sup>	42 <sup>21</sup>			-97.1	-94.7	-93.2	-92.5	TDD
CA_3A-28A-42A-42A <sup>12,13</sup>	42 <sup>21</sup>			-85.7	-85.4	-85.1	-84.9	TDD
CA_3A-28A-42A-42C <sup>8,9</sup>	42 <sup>21</sup>			-71.7	-71.7	-71.7	-71.7	TDD
CA_3A-28A-42A-42C <sup>10</sup>	42 <sup>21</sup>			-97.1	-94.7	-93.2	-92.5	TDD
CA_3A-28A-42A-42C <sup>12,13</sup>	42 <sup>21</sup>			-85.7	-85.4	-85.1	-84.9	TDD
CA_3A-28A-42C-42C <sup>8,9</sup>	42 <sup>21</sup>			-71.7	-71.7	-71.7	-71.7	TDD
CA_3A-28A-42C-42C <sup>10</sup>	42 <sup>21</sup>			-97.1	-94.7	-93.2	-92.5	TDD
CA_3A-28A-42C-42C <sup>12,13</sup>	42 <sup>21</sup>			-85.7	-85.4	-85.1	-84.9	TDD
CA_3A-41A-42A-42A <sup>8,9,20</sup>	42 <sup>21</sup>			-71.7	-71.7	-71.7	-71.7	TDD
CA_3A-41A-42A-42A <sup>10,20</sup>	42 <sup>21</sup>			-94.7	-93.2	-92.5	-92.5	TDD
CA_3A-41A-42A-42C <sup>8,9,20</sup>	42 <sup>21</sup>			-71.7	-71.7	-71.7	-71.7	TDD
CA_3A-41A-42A-42C <sup>10,20</sup>	42 <sup>21</sup>			-94.7	-93.2	-92.5	-92.5	TDD
CA_3A-41A-42C-42C <sup>8,9,20</sup>	42 <sup>21</sup>			-71.7	-71.7	-71.7	-71.7	TDD
CA_3A-41A-42C-42C <sup>10,20</sup>	42 <sup>21</sup>			-94.7	-93.2	-92.5	-92.5	TDD
CA_3A-42C <sup>8,9</sup>	42 <sup>21</sup>			-71.7	-71.7	-71.7	-71.7	TDD
CA_3A-42C <sup>10</sup>	42 <sup>21</sup>			-97.1	-94.7	-93.2	-92.5	TDD
CA_3A-42D <sup>8,9</sup>	42 <sup>21</sup>			-71.7	-71.7	-71.7	-71.7	TDD
CA_3A-42D <sup>10</sup>	42 <sup>21</sup>			-97.1	-94.7	-93.2	-92.5	TDD
CA_3A-3A-42C <sup>8,9</sup>	42 <sup>21</sup>			-71.7	-71.7	-71.7	-71.7	TDD
CA_3A-3A-42C <sup>10</sup>	42 <sup>21</sup>			-97.1	-94.7	-93.2	-92.5	TDD
CA_3A-3A-42D <sup>9,10</sup>	42 <sup>21</sup>			-71.7	-71.7	-71.7	-71.7	TDD
CA_3A-3A-42D <sup>11</sup>	42 <sup>21</sup>			-97.1	-94.7	-93.2	-92.5	TDD
CA_3A-42A-42C <sup>8,9</sup>	42 <sup>21</sup>			-71.7	-71.7	-71.7	-71.7	TDD
CA_3A-42A-42C <sup>10</sup>	42 <sup>21</sup>			-97.1	-94.7	-93.2	-92.5	TDD
CA_3A-42C-42C <sup>8,9,10</sup>	42 <sup>21</sup>			-71.7	-71.7	-71.7	-71.7	TDD
CA_3A-42C-42C <sup>11</sup>	42 <sup>21</sup>			-97.1	-94.7	-93.2	-92.5	TDD
CA_3A-42E <sup>9,10</sup>	42 <sup>21</sup>			-71.7	-71.7	-71.7	-71.7	TDD
CA_3A-42E <sup>11</sup>	42 <sup>21</sup>			-97.1	-94.7	-93.2	-92.5	TDD
CA_3C-8A <sup>4</sup>	3			N/A	N/A	N/A	N/A	FDD
CA_4A-4A-5A-12A <sup>5,6</sup>	4 <sup>21</sup>			-90	-89.5	-89	-88.5	FDD
CA_4A-4A-12A <sup>5,6</sup>	4			-90	-89.5	-89	-88.5	FDD
CA_4A-4A-12A-12A <sup>5,6</sup>	4 <sup>21</sup>			-90	-89.5	-89	-88.5	FDD
CA_4A-4A-12A-30A <sup>5,6</sup>	4 <sup>21</sup>			-90	-89.5	-89	-88.5	FDD
CA_4A-4A-12B <sup>5,6</sup>	4 <sup>21</sup>			-90	-89.5	-89	-88.5	FDD
CA_4A-5A-12B <sup>5,6</sup>	4 <sup>21</sup>			-90	-89.5	-89	-88.5	FDD

CA_4A-12A-12A <sup>5,6</sup>	4 <sup>21</sup>			-90	-89.5	-89	-88.5	FDD
CA_4A-12B <sup>5,6</sup>	4 <sup>21</sup>			-90	-89.5	-89	-88.5	FDD
CA_4A-5A-12A-12A <sup>5,6</sup>	4 <sup>21</sup>			-90	-89.5	-89	-88.5	FDD
CA_7A-7A-8A <sup>5,6</sup>	7 <sup>21</sup>			-88	-87.4	-87	-86.7	FDD
CA_8A-41C <sup>7</sup>	41				N/A	N/A	N/A	TDD
CA_8A-42C <sup>15,16</sup>	42 <sup>21</sup>			-84.8	-84.7	-84.6	-84.5	TDD
CA_12A-30A-66A-66A <sup>5,6</sup>	66 <sup>21</sup>			-89.5	-89	-88.5	-88	FDD
CA_12A-66A-66A <sup>5,6</sup>	66 <sup>21</sup>			-89.5	-89	-88.5	-88	FDD
CA_12A-66C <sup>5,6</sup>	66 <sup>21</sup>			-89.5	-89	-88.5	-88	FDD
CA_12B-66A <sup>5,6</sup>	66 <sup>21</sup>			-89.5	-89	-88.5	-88	FDD
CA_12B-66A-66A <sup>5,6</sup>	66 <sup>21</sup>			-89.5	-89	-88.5	-88	FDD
CA_20A-38A-40A-40A <sup>15,16</sup>	20			-60.7	-60.7	-60.7		FDD
CA_20A-38A-40C <sup>15,16</sup>	20			-60.7	-60.7	-60.7		FDD
CA_20A-40D <sup>7</sup>	20			-60.7	-60.7	-60.7		FDD
CA_21A-28A-42C <sup>4,14</sup>	21			N/A	N/A	N/A	N/A	FDD
	42			N/A	N/A			TDD
CA_25A-25A-26A-41C <sup>7</sup>	41			N/A	N/A	N/A	N/A	TDD
CA_26A-41C <sup>7</sup>	41			N/A	N/A	N/A	N/A	TDD
CA_28A-40C <sup>16,17</sup>	28 <sup>21</sup>			-60.7	-60.7	-60.7	-60.7	FDD
CA_28A-40D <sup>16,17</sup>	28 <sup>21</sup>			-60.7	-60.7	-60.7	-60.7	FDD
CA_28A-41A-42C <sup>12,13</sup>	42 <sup>21</sup>				-85.4	-85.1	-84.9	TDD
CA_28A-41C-42A <sup>12,13</sup>	42 <sup>21</sup>				-85.4	-85.1	-84.9	TDD
CA_28A-41C-42C <sup>12,13</sup>	42 <sup>21</sup>				-85.4	-85.1	-84.9	TDD
CA_28A-42C <sup>12,13</sup>	42 <sup>21</sup>			-85.7	-85.4	-85.1	-84.9	TDD
CA_28A-42D <sup>12,13</sup>	42 <sup>21</sup>				-85.4	-85.1	-84.9	TDD
CA_28A-41A-42A-42A <sup>12,13</sup>	42 <sup>21</sup>				-85.4	-85.1	-84.9	TDD
CA_28A-41A-42A-42C <sup>12,13</sup>	42 <sup>21</sup>				-85.4	-85.1	-84.9	TDD
CA_28A-41A-42A-42C <sup>12,13</sup>	42 <sup>21</sup>				-85.4	-85.1	-84.9	TDD
CA_28A-42A-42A <sup>12,13</sup>	42 <sup>21</sup>			-85.7	-85.4	-85.1	-84.9	TDD
CA_28A-42A-42C <sup>12,13</sup>	42 <sup>21</sup>			-85.7	-85.4	-85.1	-84.9	TDD
CA_28A-42C-42C <sup>12,13</sup>	42 <sup>21</sup>			-85.7	-85.4	-85.1	-84.9	TDD
CA_48A-48C-66A <sup>8,9</sup>	48			-71.7	-71.7	-71.7	-71.7	TDD
CA_48A-48C-66A <sup>10</sup>	48			-97.1	-94.7	-93.2	-92.5	TDD
CA_48A-48C-66B <sup>8,9</sup>	48			-71.7	-71.7	-71.7	-71.7	TDD
CA_48A-48C-66B <sup>10</sup>	48			-97.1	-94.7	-93.2	-92.5	TDD
CA_48A-48C-66C <sup>8,9</sup>	48			-71.7	-71.7	-71.7	-71.7	TDD
CA_48A-48C-66C <sup>10</sup>	48			-97.1	-94.7	-93.2	-92.5	TDD
CA_48A-48D-66A <sup>8,9</sup>	48			-71.7	-71.7	-71.7	-71.7	TDD
CA_48A-48D-66A <sup>10</sup>	48			-97.1	-94.7	-93.2	-92.5	TDD
CA_48C-48C-66A <sup>8,9</sup>	48			-71.7	-71.7	-71.7	-71.7	TDD
CA_48C-48C-66A <sup>10</sup>	48			-97.1	-94.7	-93.2	-92.5	TDD
CA_48D-66A <sup>8,9</sup>	48			-71.7	-71.7	-71.7	-71.7	TDD
CA_48D-66A <sup>10</sup>	48			-97.1	-94.7	-93.2	-92.5	TDD

- NOTE 1: The transmitter shall be set to  $P_{UMAX}$  as defined in subclause 6.2.5A.
- NOTE 2: Reference measurement channel is A.3.2 with one sided dynamic OCNG Pattern OP.1 FDD/TDD as described in Annex A.5.1.1/A.5.2.1
- NOTE 3: The signal power is specified per port
- NOTE 4: No requirements apply when there is at least one individual RE within the uplink transmission bandwidth of the low band for which the 2nd transmitter harmonic is within the downlink transmission bandwidth of the high band. The reference sensitivity for all active downlink component carriers is only verified when this is not the case (the requirements specified in clause 7.3.1 apply unless otherwise specified).
- NOTE 5: These requirements apply when there is at least one individual RE within the uplink transmission bandwidth of a low band for which the 3rd transmitter harmonic is within the downlink transmission bandwidth of a high band.
- NOTE 6: The requirements should be verified for UL EARFCN of a low band (superscript LB) such that  $f_{UL}^{LB} = f_{DL}^{HB} / 0.3 \lfloor 0.1$  in MHz and  $F_{UL\_low}^{LB} + BW_{Channel}^{LB} / 2 \leq f_{UL}^{LB} \leq F_{UL\_high}^{LB} - BW_{Channel}^{LB} / 2$  with  $f_{DL}^{HB}$  the carrier frequency of a high band in MHz and  $BW_{Channel}^{LB}$  the channel bandwidth configured in the low band.
- NOTE 7: No requirements apply when there is at least one individual RE within the uplink transmission bandwidth of the low band for which the 3rd transmitter harmonic is within the downlink transmission bandwidth of the high band. The reference sensitivity is only verified when this is not the case (the requirements specified in clause 7.3.1 apply).
- NOTE 8: These requirements apply when there is at least one individual RE within the uplink transmission bandwidth of the aggressor (lower) band for which the 2nd transmitter harmonic is within the downlink transmission bandwidth of a victim (higher) band and a range  $\Delta F_{HD}$  above and below the edge of this downlink transmission bandwidth. The value  $\Delta F_{HD}$  depends on the E-UTRA configuration:  $\Delta F_{HD} = 10$  MHz for CA\_3A-42C, CA\_3A-42D, CA\_3A-3A-42C, CA\_3A-42A-42C, CA\_3A-42C-42C, CA\_1A-3A-18A-42C, CA\_1A-3A-19A-42C, CA\_1A-3A-21A-42C, CA\_1A-3A-41A-42C, CA\_1A-3A-41C-42A, CA\_1A-3A-41C-42C, CA\_1A-3A-42C, CA\_3A-28A-42C, CA\_3A-28A-42D, CA\_3A-19A-42C, CA\_3A-19A-42D, CA\_3A-21A-42D, CA\_3A-28A-40C, CA\_3A-28A-40D, CA\_3A-28A-41A-42C, CA\_3A-28A-41C-42A, CA\_3A-28A-41C-42C, CA\_3A-28A-42A-42A, CA\_3A-28A-42A-42C, CA\_3A-28A-42C-42C, CA\_3A-41A-42A-42A, CA\_3A-41A-42A-42C, CA\_3A-41A-42C-42C, CA\_2A-48C-48C, CA\_2A-48A-48D, CA\_48A-48C-66C, CA\_48A-48C-66B, CA\_48A-48D-66A, CA\_48C-48C-66A, CA\_48D-66A, CA\_48A-48C-66A, CA\_2A-13A-48D, CA\_2A-13A-48A-48C, CA\_2A-13A-48C-66A, CA\_2A-13A-48A-48A-66A, CA\_2A-48D-66A, CA\_2A-48E-66A, CA\_2A-48A-48C-66A and CA\_2A-48E.
- NOTE 9: The requirements should be verified for UL EARFCN of the aggressor (lower) band (superscript LB) such that  $f_{UL}^{LB} = f_{DL}^{HB} / 0.2 \lfloor 0.1$  in MHz and  $F_{UL\_low}^{LB} + BW_{Channel}^{LB} / 2 \leq f_{UL}^{LB} \leq F_{UL\_high}^{LB} - BW_{Channel}^{LB} / 2$  with  $f_{DL}^{HB}$  carrier frequency in the victim (higher) band in MHz and  $BW_{Channel}^{LB}$  the channel bandwidth configured in the lower band.
- NOTE 10: The requirements are only applicable to channel bandwidths with a carrier frequency at  $\pm (20 + BW_{Channel}^{HB} / 2)$  MHz offset from  $2f_{UL}^{LB}$  in the victim (higher) band with  $F_{UL\_low}^{LB} + BW_{Channel}^{LB} / 2 \leq f_{UL}^{LB} \leq F_{UL\_high}^{LB} - BW_{Channel}^{LB} / 2$ , where  $BW_{Channel}^{LB}$  and  $BW_{Channel}^{HB}$  are the channel bandwidths configured in the aggressor (lower) and victim (higher) bands in MHz, respectively.
- NOTE 11: Void
- NOTE 12: These requirements apply when there is at least one individual RE within the uplink transmission bandwidth of a low band for which the 5<sup>th</sup> transmitter harmonic is within the downlink transmission bandwidth of a high band.
- NOTE 13: The requirements should be verified for UL EARFCN of a low band (superscript LB) such that  $f_{UL}^{LB} = \lfloor f_{DL}^{HB} / 0.5 \rfloor 0.1$  in MHz and  $F_{UL\_low}^{LB} + BW_{Channel}^{LB} / 2 \leq f_{UL}^{LB} \leq F_{UL\_high}^{LB} - BW_{Channel}^{LB} / 2$  with  $f_{DL}^{HB}$  the carrier frequency of a high band in MHz and  $BW_{Channel}^{LB}$  the channel bandwidth configured in the low band.
- NOTE 14: No requirements apply when there is at least one individual RE on band 28 uplink outside frequencies 728 – 738 MHz. The reference sensitivity is only verified when all configured RE's are confined within frequencies 728 – 738 MHz (the requirements specified in clause 7.3.1 of [6] apply).
- NOTE 15: These requirements apply when there is at least one individual RE within the uplink transmission bandwidth of a low band for which the 4<sup>th</sup> transmitter harmonic is within the downlink transmission bandwidth of a high band.
- NOTE 16: The requirements should be verified for UL EARFCN of a low band (superscript LB) such that  $f_{UL}^{LB} = \lfloor f_{DL}^{HB} / 0.4 \rfloor 0.1$  in MHz and  $F_{UL\_low}^{LB} + BW_{Channel}^{LB} / 2 \leq f_{UL}^{LB} \leq F_{UL\_high}^{LB} - BW_{Channel}^{LB} / 2$  with  $f_{DL}^{HB}$  the carrier frequency of a high band in MHz and  $BW_{Channel}^{LB}$  the channel bandwidth configured in the low band.

NOTE 17: These requirements apply when there is at least one individual RE within the downlink transmission bandwidth of the victim (lower) band for which the 3<sup>rd</sup> harmonic is within the uplink transmission bandwidth or the uplink adjacent channel's transmission bandwidth of an aggressor (higher) band.

NOTE 18: The requirements should be verified for UL EARFCN of the aggressor (higher) band (superscript HB) such that  $f_{DL}^{LB} = \lfloor f_{UL}^{HB} / 0.3 \rfloor 0.1$  in MHz and

$$F_{UL\_low}^{LB} + BW_{Channel}^{LB} / 2 \leq f_{UL}^{LB} \leq F_{UL\_high}^{LB} - BW_{Channel}^{LB} / 2 \quad \text{with } f_{DL}^{LB} \text{ the carrier frequency in the victim (lower) band and } BW_{Channel}^{HB} \text{ the channel bandwidth configured in the higher band.}$$

NOTE 19: The requirement for B46 does not apply when there is at least one individual RE within the B46 downlink transmission bandwidth which falls into the reference sensitivity exclusion region as specified in Table 6.2.4-3.

NOTE 20: The B41 requirements are modified by -0.1dB when carrier frequency of the assigned E-UTRA channel bandwidth is within 2545-2690 MHz.

NOTE 21: Applicable for the operations with 2 or 4 antenna ports supported in the band with carrier aggregation configured.

NOTE 22: These requirements apply when there is at least one individual RE within the uplink transmission bandwidth of the aggressor (lower) band for which the 2nd transmitter harmonic is within the downlink transmission bandwidth of a victim (higher) band and a range  $\Delta F_{HD}$  above and below the edge of this downlink transmission bandwidth. The value  $\Delta F_{HD}$  depends on the E-UTRA configuration:  $\Delta F_{HD} = 10$  MHz for CA\_2A-48A-48C

**Table 7.3.1A-6: Uplink configuration for the low band (exceptions due to harmonic issues in the combinations of intra-band and inter-band CA)**

E-UTRA Band / Channel bandwidth of the high band / N <sub>RB</sub> / Duplex mode								
EUTRA CA Configuration	UL band	1.4 MHz	3 MHz	5 MHz	10 MHz	15 MHz	20 MHz	Duplex mode
CA_1A-3A-3A-7A-8A CA_1A-3A-7A-7A-8A CA_1A-3A-3A-7A-7A-8A	8			8	16	25	25	FDD
CA_1A-1A-3A-7A-28A CA_1A-1A-3A-7C-28A CA_1A-1A-3C-7A-28A CA_1A-1A-3C-7C-28A CA_1A-1A-3A-3A-7A-28A CA_1A-1A-3A-3A-7C-28A CA_1A-3A-7C-28A CA_1A-3C-7A-28A CA_1A-3C-7C-28A CA_1A-3A-3A-7A-28A CA_1A-3A-3A-7C-28A CA_1A-3A-7A-7A-28A	28			8	16	25	25	FDD
CA_1A-3A-8A-42C	8			8	16	25	25	FDD
CA_1A-3A-8A-42C	3			12	25	36	50	FDD
CA_1A-3A-18A-42C	3			12	25	36	50	FDD
CA_1A-3A-19A-42C	3			12	25	36	50	FDD
CA_1A-3A-3A-20A-28A	28			8	16	25	25	FDD
CA_1A-3A-21A-42C	3			12	25	36	50	FDD
CA_1A-3C-28A	28			8	16	25	25	FDD
CA_1A-3A-28A-40C	40			25	50	75	100	TDD
CA_1A-3A-28A-42C	3			12	25	36	50	FDD
CA_1A-3A-42C	3			12	25	36	50	FDD
CA_1A-3A-42D	3			12	25	36	50	FDD
CA_1A-3A-3A-42C	3			12	25	36	50	FDD
CA_1A-7A-8A-40C	8			8	16	25	25	FDD
CA_1A-7C-28A	28				16	25	25	FDD
CA_1A-7A-28A-40C	40			25	50	75	100	TDD
CA_1A-8A-11A-42C	8			8	16	25	25	FDD
CA_1A-28A-42C	28			8	16	25	25	FDD
CA_2A-2A-4A-12A	12			8	16	20	20	FDD
CA_2A-2A-5A-12A-66A	12			8	16	20	20	FDD
CA_2A-2A-7A-12A-66A	12			8	16			FDD
CA_2A-2A-12A-30A-66A	12			8	16	25	25	FDD
CA_2A-2A-12A-66A	12			8	16			FDD
CA_2A-2A-12A-66A-66A	12			8	16	20	20	FDD
CA_2A-2A-12B-66A	12			8	16	20	20	FDD
CA_2A-4A-4A-12A	12			8	16	20	20	FDD
CA_2A-4A-12A-12A	12			8	16	20	20	FDD

CA_2A-4A-12B	12			8	16			FDD
CA_2A-7A-12B-66A	12			8	16			FDD
CA_2A-12A-30A-66A-66A	12			8	16	25	25	FDD
CA_2A-12A-66A-66A	12			8	16			FDD
CA_2A-12A-66C	12			8	16			FDD
CA_2A-12B-66A	12			8	16	20	20	FDD
CA_2A-12B-66A-66A	12			8	16	20	20	FDD
CA_2A-13A-48A-48A CA_2A-13A-48C	2			25	50	50 <sup>1</sup>	50 <sup>1</sup>	FDD
CA_2A-13A-48D	2			25	50	50 <sup>1</sup>	50 <sup>1</sup>	FDD
CA_2A-13A-48A-48C	2			25	50	50 <sup>1</sup>	50 <sup>1</sup>	FDD
CA_2A-13A-48C-66A	2			25	50	50 <sup>1</sup>	50 <sup>1</sup>	FDD
	66			12 <sup>1</sup>	25 <sup>1</sup>	36 <sup>1</sup>	50 <sup>1</sup>	FDD
CA_2A-13A-48A-48A-66A	2			25	50	50 <sup>1</sup>	50 <sup>1</sup>	FDD
	66			12 <sup>1</sup>	25 <sup>1</sup>	36 <sup>1</sup>	50 <sup>1</sup>	FDD
CA_2A-48A-48D	2			25	50	50 <sup>1</sup>	50 <sup>1</sup>	FDD
CA_2A-48C-48C	2			25	50	50 <sup>1</sup>	50 <sup>1</sup>	FDD
CA_2A-48D	2			25	50	50 <sup>1</sup>	50 <sup>1</sup>	FDD
CA_2A-48E	2			25	50	50 <sup>1</sup>	50 <sup>1</sup>	FDD
CA_2A-48A-48A-66A	2			25	50	50 <sup>1</sup>	50 <sup>1</sup>	FDD
	66			12 <sup>1</sup>	25 <sup>1</sup>	36 <sup>1</sup>	50 <sup>1</sup>	FDD
CA_2A-48D-66A	2			25	50	50 <sup>1</sup>	50 <sup>1</sup>	FDD
	66			12 <sup>1</sup>	25 <sup>1</sup>	36 <sup>1</sup>	50 <sup>1</sup>	FDD
CA_2A-48E-66A	2			25	50	50 <sup>1</sup>	50 <sup>1</sup>	FDD
	66			12 <sup>1</sup>	25 <sup>1</sup>	36 <sup>1</sup>	50 <sup>1</sup>	FDD
CA_2A-48A-48C-66A	2			25	50	50 <sup>1</sup>	50 <sup>1</sup>	FDD
	66			12 <sup>1</sup>	25 <sup>1</sup>	36 <sup>1</sup>	50 <sup>1</sup>	FDD
CA_3A-3A-7A-7A-8A	8			8	16	25	25	FDD
CA_3A-3A-7A-8A	8			8	16	25	25	FDD
CA_3A-7A-7A-8A	8			8	16	25	25	FDD
CA_3A-7A-8A-40C	8			8	16	25	25	FDD
CA_3A-19A-42C	3			12	25	36	50	FDD
CA_3A-19A-42D	3			12	25	36	50	FDD
CA_3A-7A-28A-40C	40			25	50	75	100	TDD
CA_3A-42C	3			12	25	36	50	FDD
CA_3A-3A-42D	3			12	25	36	50	FDD
CA_3A-42C-42C	3			12	25	36	50	FDD
CA_3A-42E	3			12	25	36	50	FDD
CA_3A-21A-42C	3			12	25	36	50	FDD
CA_3A-21A-42D	3			12	25	36	50	FDD
CA_3A-28A-40C	40			25	50	75	100	TDD
CA_3A-28A-40D	40				50	75	100	TDD
CA_3A-28A-41A-42C	3				25	36	50	FDD
	28				10	15	20	FDD
CA_3A-28A-41C-42A	3				25	36	50	FDD
	28				10	15	20	FDD
CA_3A-28A-41C-42C	3				25	36	50	FDD
	28				10	15	20	FDD



CA_3A-28A-42C	3			12	25	36	50	FDD
	28			5	10	15	20	FDD
CA_3A-28A-42A-42A	3			12	25	36	50	FDD
	28			5	10	15	20	FDD
CA_3A-28A-42A-42C	3			12	25	36	50	FDD
	28			5	10	15	20	FDD
CA_3A-28A-42C-42C	3			12	25	36	50	FDD
	28			5	10	15	20	FDD
CA_3A-41A-42A-42A	3				25	36	50	FDD
CA_3A-41A-42A-42C	3				25	36	50	FDD
CA_3A-41A-42C-42C	3				25	36	50	FDD
CA_4A-4A-5A-12A	12			8	16	20	20	FDD
CA_4A-4A-12A	12			8	16	20	20	FDD
CA_4A-4A-12A-12A	12			8	16	20	20	FDD
CA_4A-4A-12A-30A	12			8	16	20	20	FDD
CA_4A-4A-12B	12			8	16			FDD
CA_4A-12A-12A	12			8	16	20	20	FDD
CA_4A-12B	12			8	16	20	20	FDD
CA_4A-5A-12A-12A	12			8	16	20	20	FDD
CA_4A-5A-12B	12			8	16			FDD
CA_7A-7A-8A	8			8	16	25	25	FDD
CA_8A-42C	8			8	16	25	25	FDD
CA_12A-30A-66A-66A	12			8	16			FDD
CA_12A-66A-66A	12			8	16	20	20	FDD
CA_12A-66C	12			8	16	20	20	FDD
CA_12B-66A	12			8	16	20	20	FDD
CA_12B-66A-66A	12			8	16	20	20	FDD
CA_20A-38A-40A-40A <sup>3</sup>	40			25	50	75		TDD
CA_20A-38A-40C <sup>3</sup>	40			25	50	75		TDD
CA_20A-40D <sup>3</sup>	40			25	50	75		TDD
CA_28A-40C	40			25	50	75	100	TDD
CA_28A-40D	40			25	50	75	100	TDD
CA_28A-41A-42C	28				10	15	20	FDD
CA_28A-41C-42A	28				10	15	20	FDD
CA_28A-41C-42C	28				10	15	20	FDD
CA_28A-41A-42A-42A	28				10	15	20	FDD
CA_28A-41A-42A-42C	28				10	15	20	FDD
CA_28A-41A-42C-42C	28				10	15	20	FDD
CA_28A-42C CA_28A-42D	28			5	10	15	20	FDD
CA_28A-42A-42A CA_28A-42A-42C CA_28A-42C-42C	28			5	10	15	20	FDD
CA_48A-48C-66A	66			12	25	36	50	FDD
CA_48A-48C-66B	66			12	25	36	50	FDD
CA_48A-48C-66C	66			12	25	36	50	FDD
CA_48A-48D-66A	66			12	25	36	50	FDD
CA_48C-48C-66A	66			12	25	36	50	FDD
CA_48D-66A	66			12	25	36	50	FDD

NOTE 1: refers to the UL resource blocks, which shall be centred within the transmission bandwidth configuration for the channel bandwidth.  
 NOTE 2: the UL configuration applies regardless of the channel bandwidth of the low band unless the UL resource blocks exceed that specified in Table 7.3.1-2 for the uplink bandwidth in which case the allocation according to Table 7.3.1-2 applies.  
 NOTE 3: refers to the UL resource blocks shall be located between 2373-2400MHz.

### 7.3.1B Minimum requirements (QPSK) for UL-MIMO

For UE with two transmitter antenna connectors in closed-loop spatial multiplexing scheme, the minimum requirements in Clause 7.3.1 shall be met with the UL-MIMO configurations specified in Table 6.2.2B-2. For UL-MIMO, the parameter  $P_{UMAX}$  is the total transmitter power over the two transmits power over the two transmit antenna connectors.

### 7.3.1D Minimum requirements (QPSK) for ProSe

When UE is configured for E-UTRA ProSe reception non-concurrent with E-UTRA uplink transmissions for E-UTRA ProSe operating bands specified in Table 5.5D-1, the throughput shall be  $\geq 95\%$  of the maximum throughput of the reference measurement channels as specified in Annexes A.6.2 with parameters specified in Table 7.3.1D-1 and Table 7.3.1D-2.

**Table 7.3.1D-1: Reference sensitivity for ProSe Direct Discovery QPSK  $P_{REFSENS}$**

E-UTRA ProSe Band	Channel bandwidth						Duplex Mode
	1.4 MHz (dBm)	3 MHz (dBm)	5 MHz (dBm)	10 MHz (dBm)	15 MHz (dBm)	20 MHz (dBm)	
2			-104.1	-104.1	-104.1	-104.1	HD
3			-103.1	-103.1	-103.1	-103.1	HD
4			-106.1	-106.1	-106.1	-106.1	HD
7			-103.8	-103.8	-103.8	-103.8	HD
14			-103.1	-103.1			HD
20			-103.2	-103.2	-102.2	-102.2	HD
26			-103.5 <sup>5</sup>	-103.5 <sup>5</sup>	-103.5 <sup>5</sup>		HD
28			-104.4	-104.4	-104.4	-102.9	HD
31			-99.5				HD
68			-104.4	-104.4	-104.4		HD
72			-99.5				HD

NOTE 1: Reference measurement channel is A.6.2  
 NOTE 2: The signal power is specified per port  
 NOTE 3: For the UE which supports both Band 3 and Band 9 the reference sensitivity level is FFS.  
 NOTE 4: For the UE which supports both Band 11 and Band 21 the reference sensitivity level is FFS.  
 NOTE 5: <sup>5</sup> indicates that the requirement is modified by -0.5 dB when the carrier frequency of the assigned E-UTRA channel bandwidth is within 865-894 MHz.  
 NOTE 6: For a UE that support both Band 18 and Band 26, the reference sensitivity level for Band 26 applies for the applicable channel bandwidths.

Table 7.3.1D-2: Reference sensitivity for ProSe Direct Communication QPSK  $P_{\text{REFSENS}}$ 

E-UTRA ProSe Band	Channel bandwidth						Duplex Mode
	1.4 MHz (dBm)	3 MHz (dBm)	5 MHz (dBm)	10 MHz (dBm)	15 MHz (dBm)	20 MHz (dBm)	
3				-97.6			HD
7				-98.3			HD
14				-97.6			HD
20				-97.7			HD
26				-98.0 <sup>5</sup>			HD
28				-98.9			HD
31			-96.7				HD
68			-101.7	-98.9			HD
72			-96.7				HD

NOTE 1: Reference measurement channel is A.6.2  
NOTE 2: The signal power is specified per port  
NOTE 3: For the UE which supports both Band 3 and Band 9 the reference sensitivity level is FFS.  
NOTE 4: For the UE which supports both Band 11 and Band 21 the reference sensitivity level is FFS.  
NOTE 5: <sup>5</sup> indicates that the requirement is modified by -0.5 dB when the carrier frequency of the assigned E-UTRA channel bandwidth is within 865-894 MHz.  
NOTE 6: For a UE that support both Band 18 and Band 26, the reference sensitivity level for Band 26 applies for the applicable channel bandwidths.

NOTE: Table 7.3.1D-1/ Table 7.3.1D-2 is intended for conformance tests and does not necessarily reflect the operational conditions of the network, where the number of allocated resource blocks will be practically constrained by other factors.

For the UE which supports ProSe in an operating band as specified in Section 5.5D, and the UE also supports a E-UTRA downlink inter-band carrier aggregation configuration in Table 7.3.1-1A or Table 7.3.1-1B, the minimum requirement for reference sensitivity in Table 7.3.1D-1 and Table 7.3.1D-2 shall be increased by the amount given in  $\Delta R_{\text{IB},c}$  in Table 7.3.1-1A and Table 7.3.1-1B for the corresponding E-UTRA ProSe band.

When UE is configured for E-UTRA ProSe reception on PCC for the inter-band E-UTRA ProSe / E-UTRA bands specified in Table 5.5D-2, there are no further requirements for reference sensitivity beyond those specified above when only PCC is configured in Table 7.3.1D-1 and Table 7.3.1D-2.

When UE is configured for E-UTRA ProSe reception on SCC or a non-serving carrier concurrent with E-UTRA uplink for inter-band E-UTRA ProSe / E-UTRA bands specified in Table 5.5D-2, E-UTRA ProSe throughput shall be  $\geq 95\%$  of the maximum throughput of the reference measurement channels as specified in Annexes A.6.2 with parameters specified in Table 7.3.1D-1 and Table 7.3.1D-2. The reference sensitivity is defined to be met with E-UTRA uplink assigned to one band (that differs from the ProSe operating band) and all E-UTRA downlink carriers active. The E-UTRA uplink resource blocks shall be located as close as possible to E-UTRA ProSe operating band but confined within the transmission bandwidth configuration for the channel bandwidth (Table 5.6-1). The uplink configuration for the E-UTRA operating band is specified in Table 7.3.1D-3.

NOTE: The E-UTRA uplink channel bandwidth and transmission bandwidth specified in this Table 7.3.1D-3 are intended for conformance tests and does not restrict the operating conditions of the network.

Table 7.3.1D-3: Uplink configuration for E-UTRA band / E-UTRA CA band

Inter-band E-UTRA ProSe/E-UTRA configuration		E-UTRA UL band / Channel BW / N <sub>RB</sub> / Duplex mode			
E-UTRA ProSe band	E-UTRA band / E-UTRA CA band	E-UTRA UL band	Channel Bandwidth (MHz)	N <sub>RB</sub>	Duplex Mode
2	4	4	5	25	FDD
2	CA_2-4	4	5	25	FDD
28	1	1	5	25	FDD
28	CA_1-28	1	5	25	FDD

NOTE 1: For E-UTRA ProSe reception on SCC, the channel bandwidth of the E-UTRA downlink SCC is set same as the ProSe channel bandwidth for which reference sensitivity is being measured.

### 7.3.1E Minimum requirements (QPSK) for UE category 0, M1, M2 and 1bis

The throughput shall be  $\geq 95\%$  of the maximum throughput of the reference measurement channels as specified in Annexes A.2.2, A.2.3 and A.3.2 (with one sided dynamic OCNG Pattern OP.1 FDD/TDD for the DL-signal as described in Annex A.5.1.1/A.5.2.1) with parameters specified in Table 7.3.1E-1A/Table 7.3.1E-1B and Table 7.3.1E-2 for category 0, Table 7.3.1E-3/Table 7.3.1E-4 for category M1, and Table 7.3.1E-6/Table 7.3.1E-7 for category 1bis, and Table 7.3.1E-8/Table 7.3.1E-9 for category M2.

Table 7.3.1E-1A: Reference sensitivity for FDD and TDD UE category 0 QPSK P<sub>REFSENS</sub>

E-UTRA Band	Channel bandwidth						Duplex Mode
	1.4 MHz (dBm)	3 MHz (dBm)	5 MHz (dBm)	10 MHz (dBm)	15 MHz (dBm)	20 MHz (dBm)	
2	-100.2	-97.2	-95.5	-92.5	-90.7	-89.5	FDD
3	-99.2	-96.2	-94.5	-91.5	-89.7	-88.5	FDD
4	-102.2	-99.2	-97.5	-94.5	-92.7	-91.5	FDD
5	-100.7	-97.7	-95.5	-92.5			FDD
8	-99.7	-96.7	-94.5	-91.5			FDD
13			-94	-91			FDD
20			-94.5	-91.5	-88.2	-87	FDD
25	-98.7	-95.7	-94	-91	-89.2	-88	FDD
26	-100.2	-97.2	-95 <sup>3</sup>	-92 <sup>3</sup>	-90.2 <sup>3</sup>		FDD
28		-97.7	-96	-93	-91.2	-88.5	FDD
39			-97.5	-94.5	-92.7	-91.5	TDD
40			-97.5	-94.5	-92.7	-91.5	TDD
41			-95.5	-92.5	-90.7	-89.5	TDD

NOTE 1: The transmitter shall be set to P<sub>UMAX</sub> as defined in subclause 6.2.5  
NOTE 2: Reference measurement channel is A.3.2 with one sided dynamic OCNG Pattern OP.1 FDD/TDD as described in Annex A.5.1.1/A.5.2.1  
NOTE 3: The requirement is modified by -0.5 dB when the carrier frequency of the assigned E-UTRA channel bandwidth is within 865-894 MHz

**Table 7.3.1E-1B: Reference sensitivity for HD-FDD UE category 0 QPSK  $P_{\text{REFSENS}}$** 

E-UTRA Band	Channel bandwidth						Duplex Mode
	1.4 MHz (dBm)	3 MHz (dBm)	5 MHz (dBm)	10 MHz (dBm)	15 MHz (dBm)	20 MHz (dBm)	
2	-101	-98	-96.3	-93.3	-91.5	-90.3	HD-FDD
3	-100	-97	-95.3	-92.3	-90.5	-89.3	HD-FDD
4	-103	-100	-98.3	-95.3	-93.5	-92.3	HD-FDD
5	-101.5	-98.5	-96.3	-93.3			HD-FDD
8	-100.5	-97.5	-95.3	-92.3			HD-FDD
13			-95.3	-92.3			HD-FDD
20			-95.3	-92.3	-89.5	-88.3	HD-FDD
25	-99.5	-96.5	-94.8	-91.8	-90	-88.8	HD-FDD
26	-101	-98	-95.8	-92.8			HD-FDD
28		-98.5	-96.8	-93.8	-92	-89.3	HD-FDD

NOTE 1: The transmitter shall be set to  $P_{\text{UMAX}}$  as defined in subclause 6.2.5  
NOTE 2: Reference measurement channel is A.3.2 with one sided dynamic OCNG Pattern OP.1 FDD/TDD as described in Annex A.5.1.1/A.5.2.1

The reference receive sensitivity (REFSENS) requirement specified in Table 7.3.1E-1A/Table 7.3.1E-1B shall be met for an uplink transmission bandwidth less than or equal to that specified in Table 7.3.1E-2.

Unless given by Table 7.3.1-3, the minimum requirements specified in Table 7.3.1E-1A/Table 7.3.1E-1B shall be verified with the network signalling value NS\_01 (Table 6.2.4E-1) configured.

NOTE: Table 7.3.1E-2 is intended for conformance tests and does not necessarily reflect the operational conditions of the network, where the number of uplink and downlink allocated resource blocks will be practically constrained by other factors. Typical receiver sensitivity performance with HARQ retransmission enabled and using a residual BLER metric relevant for e.g. Speech Services is given in the Annex G (informative).

**Table 7.3.1E-2: FDD and TDD UE category 0 Uplink configuration for reference sensitivity**

E-UTRA Band	E-UTRA Band / Channel bandwidth / $N_{\text{RB}}$ / Duplex mode						Duplex Mode
	1.4 MHz	3 MHz	5 MHz	10 MHz	15 MHz	20 MHz	
2	6	15	25	36 <sup>1</sup>	36 <sup>1</sup>	36 <sup>1</sup>	FDD and HD-FDD
3	6	15	25	36 <sup>1</sup>	36 <sup>1</sup>	36 <sup>1</sup>	FDD and HD-FDD
4	6	15	25	36 <sup>1</sup>	36 <sup>1</sup>	36 <sup>1</sup>	FDD and HD-FDD
5	6	15	25	25 <sup>1</sup>			FDD and HD-FDD
8	6	15	25	25 <sup>1</sup>			FDD and HD-FDD
13			20 <sup>1</sup>	20 <sup>1</sup>			FDD and HD-FDD
20			25	20 <sup>1</sup>	20 <sup>2</sup>	20 <sup>2</sup>	FDD and HD-FDD
25	6	15	25	36 <sup>1</sup>	36 <sup>1</sup>	36 <sup>1</sup>	FDD and HD-FDD
26	6	15	25	25 <sup>1</sup>	25 <sup>1</sup>		FDD and HD-FDD
28		15	25	25 <sup>1</sup>	25 <sup>1</sup>	25 <sup>1</sup>	FDD and HD-FDD
39			25	36 <sup>1</sup>	36 <sup>1</sup>	36 <sup>1</sup>	TDD
40			25	36 <sup>1</sup>	36 <sup>1</sup>	36 <sup>1</sup>	TDD
41			25	36 <sup>1</sup>	36 <sup>1</sup>	36 <sup>1</sup>	TDD

NOTE 1: <sup>1</sup> refers to the UL resource blocks shall be located as close as possible to the downlink operating band but confined within the transmission bandwidth configuration for the channel bandwidth (Table 5.6-1).  
NOTE 2: <sup>2</sup> refers to Band 20; in the case of 15MHz channel bandwidth, the UL resource blocks shall be located at  $\text{RB}_{\text{start}} 11$  and in the case of 20MHz channel bandwidth, the UL resource blocks shall be located at  $\text{RB}_{\text{start}} 16$ .

Table 7.3.1E-3: Reference sensitivity for FDD and TDD UE category M1 QPSK  $P_{\text{REFSENS}}$ 

E-UTRA Band	REFSENS (dBm)	Duplex Mode
1	-102.2	FDD
2	-100.2	FDD
3	-99.2	FDD
4	-102.2	FDD
5	-100.7	FDD
7	-100.2	FDD
8	-99.7	FDD
11	-102.2 <sup>8</sup>	FDD
12	-99.2	FDD
13	-98.7	FDD
14	-98.7	FDD
18	-102.2 <sup>4</sup>	FDD
19	-102.2	FDD
20	-99.7	FDD
21	-102.2 <sup>3</sup>	FDD
25	-98.7	FDD
26	-100.2	FDD
27	-100.7	FDD
28	-100.7	FDD
31	-96.5	FDD
...		
39	-103.7	TDD
40	-103.7	TDD
41	-101.7	TDD
42	-102.7	TDD
43	-102.7	TDD
...		
71	99.4	FDD
72	-96.5	FDD
73	-96.5	FDD
74	-101.7 <sup>8</sup>	FDD
85	-99.2	FDD
87	-96.5	FDD
88	-96.5	FDD

NOTE 1: The transmitter shall be set to  $P_{\text{UMAX}}$  as defined in subclause 6.2.5  
NOTE 2: Reference measurement channel is A.3.2 with one sided dynamic OCNG Pattern OP.1 FDD/TDD as described in Annex A.5.1.1/A.5.2.1  
NOTE 3: For the UE which supports both Band 11 and Band 21 the reference sensitivity level is FFS.  
NOTE 4: For a UE that support both Band 18 and Band 26, the reference sensitivity level for Band 26 applies for the applicable channel bandwidths.  
NOTE 5: For cat M1 the same reference sensitivity requirement applies for all applicable channel bandwidths (Table 5.6.1-1)  
NOTE 6: The reference receive sensitivity shall be met for an uplink transmission bandwidth less than or equal to 6 RB except for band 31 and 72. For band 31 and 72; in the case of 3 MHz channel bandwidth 5 RB applies and the UL resource blocks shall be located at  $\text{RB}_{\text{start}} 9$ . In case of 5 MHz channel bandwidth 5 RB applies and the UL resource blocks shall be located at  $\text{RB}_{\text{start}} 10$ .  
NOTE 7: The UL resource blocks shall be located as close as possible to the downlink operating band but confined within the transmission bandwidth configuration for the channel bandwidth.  
NOTE 8: <sup>8</sup> indicates that the requirement is modified by -0.5 dB when the assigned E-UTRA channel bandwidth is confined within 1475.9-1510.9 MHz.

**Table 7.3.1E-4: Reference sensitivity for HD-FDD UE category M1 QPSK  $P_{\text{REFSENS}}$** 

E-UTRA Band	REFSENS (dBm)	Duplex Mode
1	-103	HD-FDD
2	-101	HD-FDD
3	-100	HD-FDD
4	-103	HD-FDD
5	-101.5	HD-FDD
7	-101	HD-FDD
8	-100.5	HD-FDD
11	-103 <sup>3</sup>	HD-FDD
12	-100	HD-FDD
13	-100	HD-FDD
14	-100	HD-FDD
18	-103 <sup>4</sup>	HD-FDD
19	-103	HD-FDD
20	-100.5	HD-FDD
21	-103 <sup>3</sup>	HD-FDD
25	-99.5	HD-FDD
26	-101	HD-FDD
27	-101.5	HD-FDD
28	-101.5	HD-FDD
31	-97.3	HD-FDD
...		
71	-100.2	HD-FDD
72	-97.3	HD-FDD
73	-97.3	HD-FDD
74	-103	HD-FDD
85	-100	HD-FDD
87	-97.3	HD-FDD
88	-97.3	HD-FDD

NOTE 1: The transmitter shall be set to  $P_{\text{UMAX}}$  as defined in subclause 6.2.5  
NOTE 2: Reference measurement channel is A.3.2 with one sided dynamic OCNG Pattern OP.1 FDD/TDD as described in Annex A.5.1.1/A.5.2.1  
NOTE 3: For the UE which supports both Band 11 and Band 21 the reference sensitivity level is FFS.  
NOTE 4: For a UE that support both Band 18 and Band 26, the reference sensitivity level for Band 26 applies for the applicable channel bandwidths.  
NOTE 5: For cat M1 the same reference sensitivity requirement applies for all applicable channel bandwidths (Table 5.6.1-1)

The reference receive sensitivity (REFSENS) requirement specified in Table 7.3.1E-3/Table 7.3.1E-4 shall be met for an uplink transmission bandwidth less than or equal to that specified in Table 7.3.1E-5.

NOTE: Table 7.3.1E-5 is intended for conformance tests and does not necessarily reflect the operational conditions of the network, where the number of uplink and downlink allocated resource blocks will be practically constrained by other factors. Typical receiver sensitivity performance with HARQ retransmission enabled and using a residual BLER metric relevant for e.g. Speech Services is given in the Annex G (informative).

Table 7.3.1E-5: FDD and TDD UE category M1 Uplink configuration for reference sensitivity

E-UTRA Band	$N_{RB}$	Duplex Mode
1	6 <sup>1</sup>	FDD and HD-FDD
2	6 <sup>1</sup>	FDD and HD-FDD
3	6 <sup>1</sup>	FDD and HD-FDD
4	6 <sup>1</sup>	FDD and HD-FDD
5	6 <sup>1</sup>	FDD and HD-FDD
7	6 <sup>1</sup>	FDD and HD-FDD
8	6 <sup>1</sup>	FDD and HD-FDD
11	6 <sup>1</sup>	FDD and HD-FDD
12	6 <sup>1</sup>	FDD and HD-FDD
13	6 <sup>1</sup>	FDD and HD-FDD
14	6 <sup>1</sup>	FDD and HD-FDD
18	6 <sup>1</sup>	FDD and HD-FDD
19	6 <sup>1</sup>	FDD and HD-FDD
20	6 <sup>1</sup>	FDD and HD-FDD
21	6 <sup>1</sup>	FDD and HD-FDD
25	6 <sup>1</sup>	FDD and HD-FDD
26	6 <sup>1</sup>	FDD and HD-FDD
27	6 <sup>1</sup>	FDD and HD-FDD
28	6 <sup>1</sup>	FDD and HD-FDD
31	6 <sup>1</sup>	FDD and HD-FDD
...		
39	6 <sup>1</sup>	TDD
40	6 <sup>1</sup>	TDD
41	6 <sup>1</sup>	TDD
42	6 <sup>1</sup>	TDD
43	6 <sup>1</sup>	TDD
...		
71	6 <sup>1</sup>	FDD and HD-FDD
72	6 <sup>1</sup>	FDD and HD-FDD
73	6 <sup>1</sup>	FDD and HD-FDD
74	6 <sup>1</sup>	FDD and HD-FDD
85	6 <sup>1</sup>	FDD and HD-FDD
87	6 <sup>1</sup>	FDD and HD-FDD
88	6 <sup>1</sup>	FDD and HD-FDD

NOTE 1: <sup>1</sup> refers to the UL resource blocks shall be located as close as possible to the downlink operating band but confined within the transmission bandwidth configuration for the channel bandwidth (Table 5.6-1).



Table 7.3.1E-6: Reference sensitivity for FDD and TDD UE category 1bis QPSK  $P_{\text{REFSENS}}$ 

E-UTRA Band	Channel bandwidth						Duplex Mode
	1.4 MHz (dBm)	3 MHz (dBm)	5 MHz (dBm)	10 MHz (dBm)	15 MHz (dBm)	20 MHz (dBm)	
1			-97.5	-94	-92.2	-91	FDD
2	-100.2	-97.2	-95.5	-92	-90.2	-89	FDD
3	-99.2	-96.2	-94.5	-91	-89.2	-88	FDD
4	-102.2	-99.2	-97.5	-94	-92.2	-91	FDD
5	-100.7	-97.7	-95.5	-92.5			FDD
7			-95.5	-92	-90.2	-89	FDD
8	-99.7	-96.7	-94.5	-91.5			FDD
12	-98.7	-95.7	-94	-91			FDD
13			-94	-91			FDD
18			-97.5	-94.5	-92.7		FDD
20			-94.5	-91.5	-88.2	-87	FDD
26	-100.2	-97.2	-95.0 <sup>3</sup>	-92.0 <sup>3</sup>	-90.2 <sup>3</sup>		FDD
28		-97.7	-96.0	-93.0	-91.2	-88.5	FDD
31	-96.5	-92.5	-90.5				FDD
34			-97.5	-94.5	-92.7		
39			-97.5	-94.5	-92.7	-91.5	TDD
40			-97.5	-94.5	-92.7	-91.5	TDD
41			-95.5	-92.5	-90.7	-89.5	TDD
66	-101.7	-98.7	-97	-93.5	-91.7	-90.5	FDD
72	-96.5	-92.5	-90.5				FDD

NOTE 1: The transmitter shall be set to  $P_{\text{UMAX}}$  as defined in subclause 6.2.5  
NOTE 2: Reference measurement channel is A.3.2 with one sided dynamic OCNG Pattern OP.1 FDD/TDD as described in Annex A.5.1.1/A.5.2.1  
NOTE 3: <sup>3</sup> indicates that the requirement is modified by -0.5 dB when the carrier frequency of the assigned E-UTRA channel bandwidth is within 865-894 MHz.

Table 7.3.1E-7: FDD and TDD UE category 1bis Uplink configuration for reference sensitivity

E-UTRA Band / Channel bandwidth / $N_{RB}$ / Duplex mode							
E-UTRA Band	1.4 MHz	3 MHz	5 MHz	10 MHz	15 MHz	20 MHz	Duplex Mode
1			25	50	75	100	FDD
2	6	15	25	50	50 <sup>1</sup>	50 <sup>1</sup>	FDD
3	6	15	25	50	50 <sup>1</sup>	50 <sup>1</sup>	FDD
4	6	15	25	50	75	100	FDD
5	6	15	25	25 <sup>1</sup>			FDD
7			25	50	75	75 <sup>1</sup>	FDD
8	6	15	25	25 <sup>1</sup>			FDD
12	6	15	20 <sup>1</sup>	20 <sup>1</sup>			FDD
13			20 <sup>1</sup>	20 <sup>1</sup>			FDD
18			25	25	25		FDD
20			25	20 <sup>1</sup>	20 <sup>2</sup>	20 <sup>2</sup>	FDD
26	6	15	25	25 <sup>1</sup>	25 <sup>1</sup>		FDD
28		15	25	25 <sup>1</sup>	25 <sup>1</sup>	25 <sup>1</sup>	FDD
31	6	5 <sup>3</sup>	5 <sup>3</sup>				FDD
34			25	50	75		
39			25	50	75	100	TDD
40			25	50	75	100	TDD
41			25	50	75	100	TDD
66	6	15	25	50	75	100	FDD
72	6	5 <sup>3</sup>	5 <sup>3</sup>				FDD
NOTE 1: <sup>1</sup> refers to the UL resource blocks shall be located as close as possible to the downlink operating band but confined within the transmission bandwidth configuration for the channel bandwidth (Table 5.6-1).							
NOTE 2: <sup>2</sup> refers to Band 20; in the case of 15MHz channel bandwidth, the UL resource blocks shall be located at $RB_{start}$ 11 and in the case of 20MHz channel bandwidth, the UL resource blocks shall be located at $RB_{start}$ 16.							
NOTE 3: <sup>3</sup> refers to Bands 31 and 72; in the case of 3 MHz channel bandwidth, the UL resource blocks shall be located at $RB_{start}$ 9 and in the case of 5 MHz channel bandwidth, the UL resource blocks shall be located at $RB_{start}$ 10.							

Table 7.3.1E-8: Reference sensitivity for FDD /TDD UE category M2 QPSK  $P_{\text{REFSENS}}$ 

E-UTRA Band	Channel bandwidth						Duplex Mode
	1.4 MHz (dBm)	3 MHz (dBm)	5 MHz (dBm)	10 MHz (dBm)	15 MHz (dBm)	20 MHz (dBm)	
1			-97.7	-97.7	-97.7	-97.7	FDD
2	-100.2	-97.2	-95.7	-95.7	-95.7	-95.7	FDD
3	-99.2	-96.2	-94.7	-94.7	-94.7	-94.7	FDD
4	-102.2	-99.2	-97.7	-97.7	-97.7	-97.7	FDD
5	-100.7	-97.7	-95.7	-95.7			FDD
7			-95.7	-95.7	-95.7	-95.7	FDD
8	-99.7	-96.7	-94.7	-94.7			FDD
11			-97.7	-97.7			
12	-99.2	-96.2	-94.7	-94.7			FDD
13			-94.2	-94.2			FDD
...							
18			-97.7	-97.7	-97.7		FDD
19			-97.7	-97.7	-97.7		FDD
20			-94.7	-94.7	-94.7	-94.7	FDD
21			-97.7	-97.7	-97.7		FDD
25	-98.7	-95.7	-94.2	-94.2	-94.2	-94.2	FDD
26	-100.2	-97.2	-95.2	-95.2	-95.2		FDD
27	-100.7	-97.7	-95.7	-95.7			FDD
28		-97.7	-96.2	-96.2	-96.2	-96.2	FDD
31	-96.5	-93.2	-91.2				FDD
...							
39			-97.7	-97.7	-97.7	-97.7	TDD
40			-97.7	-97.7	-97.7	-97.7	TDD
41			-95.7	-95.7	-95.7	-95.7	TDD
42			-96.7	-96.7	-96.7	-96.7	TDD
43			-96.7	-96.7	-96.7	-96.7	TDD
66	-101.7	-98.7	-97.2	-97.2	-97.2	-97.2	FDD
...							
71	[-99.4]	[-95.4]	[-93.4]	[-93.4]	[-93.4]	[-93.4]	FDD
72	[-96.5]	[-92.5]	[-90.5]				FDD
73	[-96.5]	[-92.5]	[-90.5]				FDD
85			-94.7	-94.7			FDD
87	-96.5	-92.5	-90.5				FDD
88	-96.5	-92.5	-90.5				FDD

NOTE 1: The transmitter shall be set to PUMAX as defined in subclause 6.2.5  
NOTE 2: Reference measurement channel is A.3.2 with one sided dynamic OCNG Pattern OP.1 FDD/TDD as described in Annex A.5.1.1/A.5.2.1  
NOTE 3: For the UE which supports both Band 11 and Band 21 the reference sensitivity level is FFS.  
NOTE 4: For a UE that support both Band 18 and Band 26, the reference sensitivity level for Band 26 applies for the applicable channel bandwidths.  
NOTE 5: The UL resource blocks shall be located as close as possible to the downlink operating band but confined within the transmission bandwidth configuration for the channel bandwidth.

Table 7.3.1E-9: Reference sensitivity for HD-FDD category M2 QPSK  $P_{\text{REFSENS}}$ 

E-UTRA Band	Channel bandwidth						Duplex Mode
	1.4 MHz (dBm)	3 MHz (dBm)	5 MHz (dBm)	10 MHz (dBm)	15 MHz (dBm)	20 MHz (dBm)	
1			-97	-97	-97	-97	HD-FDD
2	-101	-97	-95	-95	-95	-95	HD-FDD
3	-100	-96	-94	-94	-94	-94	HD-FDD
4	-103	-99	-97	-97	-97	-97	HD-FDD
5	-101.5	-97.5	-95.5	-95.5			HD-FDD
7			-95	-95	-95	-95	HD-FDD
8	-100.5	-96.5	-94.5	-94.5			HD-FDD
11			-97	-97			HD-FDD
12	-100	-96	-94	-94			HD-FDD
13			-94	-94			HD-FDD
14			-94	-94			HD-FDD
18			-97	-97	-97		HD-FDD
19			-97	-97	-97		HD-FDD
20			-94.5	-94.5	-94.5	-94.5	HD-FDD
21			-97	-97	-97		HD-FDD
25	-99.5	-95.5	-93.5	-93.5	-93.5	-93.5	HD-FDD
26	-101	-97	-95	-95	-95		HD-FDD
27	-101.5	-97.5	-95.5	-95.5			HD-FDD
28		-97.5	-95.5	-95.5	-95.5	-95.5	HD-FDD
31	-97.3	-93.3	-91.3				HD-FDD
71	-100.2	-96.2	-94.2	-94.2	-94.2	-94.2	HD-FDD
72	-97.3	-93.3	-91.3				HD-FDD
73	-97.3	-93.3	-91.3				HD-FDD
85			-94	-94			HD-FDD
87	-97.3	-93.3	-91.3				HD-FDD
88	-97.3	-93.3	-91.3				HD-FDD

NOTE 1: The transmitter shall be set to PUMAX as defined in subclause 6.2.5  
NOTE 2: Reference measurement channel is A.3.2 with one sided dynamic OCNG Pattern OP.1 FDD/TDD as described in Annex A.5.1.1/A.5.2.1  
NOTE 3: For the UE which supports both Band 11 and Band 21 the reference sensitivity level is FFS.  
NOTE 4: For a UE that support both Band 18 and Band 26, the reference sensitivity level for Band 26 applies for the applicable channel bandwidths.

Table 7.3.1E-10: FDD/HD-FDD and TDD UE category M2 Uplink configuration for reference sensitivity

E-UTRA Band	E-UTRA Band / Channel bandwidth / N <sub>RB</sub> / Duplex mode						Duplex Mode
	1.4 MHz	3 MHz	5 MHz	10 MHz	15 MHz	20 MHz	
1			24	24	24	24	FDD/HD-FDD
2	6	15	24	24	24	24	FDD/HD-FDD
3	6	15	24	24	24	24	FDD/HD-FDD
4	6	15	24	24	24	24	FDD/HD-FDD
5	6	15	24	24			FDD/HD-FDD
7			24	24	24	24	FDD/HD-FDD
8	6	15	24	24			FDD/HD-FDD
11			24	24			FDD/HD-FDD
12	6	15	20 <sup>1</sup>	20 <sup>1</sup>			FDD/HD-FDD
13			20 <sup>1</sup>	20 <sup>1</sup>			FDD/HD-FDD
14			15 <sup>1</sup>	15 <sup>1</sup>			FDD/HD-FDD
18			24	24	24		FDD/HD-FDD
19			24	24	24		FDD/HD-FDD
20			24	20 <sup>1</sup>	20 <sup>3</sup>	20 <sup>3</sup>	FDD/HD-FDD
21			24	24 <sup>1</sup>	24 <sup>1</sup>		FDD/HD-FDD
25	6	15	24	24	24	24	FDD/HD-FDD
26	6	15	24	24	24		FDD/HD-FDD
27	6	15	24	24			FDD/HD-FDD
28		15	24	24	24	24	FDD/HD-FDD
31	6	5 <sup>4</sup>	5 <sup>4</sup>				FDD/HD-FDD
...							
39				24	24	24	TDD
40				24	24	24	TDD
41				24	24	24	TDD
42				24	24	24	TDD
43				24	24	24	TDD
...							
71	6	15	24	24	24	24	FDD/HD-FDD
72	6	5 <sup>4</sup>	5 <sup>4</sup>				FDD/HD-FDD
73	6	5 <sup>4</sup>	5 <sup>4</sup>				FDD/HD-FDD
85			20 <sup>1</sup>	20 <sup>1</sup>			FDD/HD-FDD
87	6	5 <sup>4</sup>	5 <sup>4</sup>				FDD/HD-FDD
88	6	5 <sup>4</sup>	5 <sup>4</sup>				FDD/HD-FDD

NOTE 1: <sup>1</sup> refers to the UL resource blocks shall be located as close as possible to the downlink operating band but confined within the transmission bandwidth configuration for the channel bandwidth (Table 5.6-1).

NOTE 2: For the UE which supports both Band 11 and Band 21 the uplink configuration for reference sensitivity is FFS.

NOTE 3: <sup>3</sup> refers to Band 20; in the case of 15MHz channel bandwidth, the UL resource blocks shall be located at RBstart 11 and in the case of 20MHz channel bandwidth, the UL resource blocks shall be located at RBstart 16

NOTE 4: <sup>4</sup> refers to Bands 31, 72 and 73; in the case of 3 MHz channel bandwidth, the UL resource blocks shall be located at RBstart 9 and in the case of 5 MHz channel bandwidth, the UL resource blocks shall be located at RBstart 10.

### 7.3.1F Minimum requirements for UE category NB1 and NB2

#### 7.3.1F.1 Reference sensitivity for UE category NB1 and NB2

The category NB1 and NB2 UE throughput shall be  $\geq 95\%$  of the maximum throughput of the reference measurement channel as specified in Annex A.3.2 with received signal level as specified in Table 7.3.1F.1-1. Requirement in Table 7.3.1F.1-1 applies for any uplink configuration.

**Table 7.3.1F.1-1: Reference sensitivity for UE category NB1 and NB2**

Operating band	REFSENS [dBm]
According to subclause 5.5F	- 108.2

7.3.1F.2 Void

**7.3.1G Minimum requirements (QPSK) for V2X**

When UE is configured for E-UTRA V2X reception non-concurrent with E-UTRA uplink transmissions for E-UTRA V2X operating bands specified in Table 5.5G-1, the throughput shall be  $\geq 95\%$  of the maximum throughput of the reference measurement channels as specified in Annexes A.8.2 with parameters specified in Table 7.3.1G-1.

**Table 7.3.1G-1: Reference sensitivity of E-UTRA V2X Bands (PC5)**

Channel bandwidth							
E-UTRA V2X Band	1.4 MHz (dBm)	3 MHz (dBm)	5 MHz (dBm)	10 MHz (dBm)	15 MHz (dBm)	20 MHz (dBm)	Duplex Mode
47				-90.4		-87.5	HD

NOTE 1: Reference measurement channel is defined in A.8.2.  
NOTE 2: The signal power is specified per port.

**Table 7.3.1G-1a: Sidelink TX configuration for reference sensitivity of E-UTRA V2X Bands (PC5)**

E-UTRA Band / Channel bandwidth / $N_{RB}$ / Duplex mode							
E-UTRA V2X Band	1.4 MHz	3 MHz	5 MHz	10 MHz	15 MHz	20 MHz	Duplex Mode
47				50		98	HD

When UE is configured for E-UTRA V2X reception on V2X carrier con-current with E-UTRA uplink and downlink for inter-band E-UTRA V2X / E-UTRA bands specified in Table 5.5G-2 with one or multiple contiguous carriers in V2X sidelink, E-UTRA V2X sidelink throughput for each component carrier shall be  $\geq 95\%$  of the maximum throughput of the reference measurement channels as specified in Annexes A.8.2 with parameters specified in Table 7.3.1G-2. Also the E-UTRA downlink throughput shall be  $\geq 95\%$  of the maximum throughput of the reference measurement channels as specified in Annexes A.3.3.2.

For the UE which supports V2X in an operating band as specified in Table 5.5G-2, and the UE also supports a E-UTRA downlink inter-band con-current configuration in Table 7.3.1G-2A, the minimum requirement for reference sensitivity in Table 7.3.1G-1 and Table 7.3.1G-2 shall be increased by the amount given in  $\Delta R_{IB,c}$  in Table 7.3.1G-2A for the corresponding E-UTRA V2X band.

Table 7.3.1G-2: Reference sensitivity for V2X Communication QPSK  $P_{\text{REFSENS}}$ 

Inter-band V2X reception		Channel bandwidth							
E-UTRA V2X Band	E-UTRA or V2X band	E-UTRA band	1.4 MHz (dBm)	3 MHz (dBm)	5 MHz (dBm)	10 MHz (dBm)	15 MHz (dBm)	20 MHz (dBm)	Duplex Mode
Band 47	Band 3	3	-101.7	-98.7	-97	-94	-92.2	-91	FDD
		47				-90.4		-87.5	HD
Band 47	Band 5	5			-98	-95			FDD
		47				-90.4		-87.5	HD
Band 47	Band 7	7			-98	-95	-93.2	-92	FDD
		47				-90.4		-87.5	HD
Band 47	Band 8	8	-102.2	-99.2	-97	-94			FDD
		47				-90.4		-87.5	HD
Band 47	Band 20	20			-97	-94	-91.2	-90	FDD
		47				-90.4		-87.5	HD
Band 47	Band 28	28		-100.2	-98.5	-95.5	-93.7	-91	FDD
		47				-90.4		-87.5	HD
Band 47	Band 34	34			-100	-97	-95.2		TDD
		47				-90.4		-87.5	HD
Band 47	Band 39	39			-100	-97	-95.2	-94	TDD
		47				-90.4		-87.5	HD
Band 47	Band 41	41			-98	-95	-93.2	-92	TDD
		47				-90.4		-87.5	HD
Band 47	Band 71	71			-97.2	-94.2	-92	-87.5	FDD
		47				-90.4		-87.5	HD

Table 7.3.1G-2A:  $\Delta R_{\text{IB,c}}$  (two bands)

V2X inter-band con-current band Combination	E-UTRA Band	$\Delta R_{\text{IB,c}}$ [dB]
V2X_3-47	3	0
V2X_5-47	5	0.2
V2X_7-47	7	0
V2X_8-47	8	0
V2X_20-47	20	0.2
V2X_28A-47A	28	0.2
V2X_34-47	34	0
V2X_39-47	39	0
V2X_41-47	41	0
V2X_71A-47A	71	0

The reference sensitivity is defined to be met with E-UTRA uplink assigned to one band (that differs from the V2X operating band) and all E-UTRA downlink carriers active. The E-UTRA uplink resource blocks shall be located as close as possible to E-UTRA V2X operating band but confined within the transmission bandwidth configuration for the channel bandwidth (Table 5.6-1). The uplink configuration for the E-UTRA operating band is specified in Table 7.3.1G-3 and 7.3.1G-4. The REFSENS of Uu downlink and PC5 sidelink will be tested at the same time.

Table 7.3.1G-3: Uplink configuration for REFSSENS of E-UTRA V2X Bands

Inter-band E-UTRA V2X /E-UTRA configuration		E-UTRA UL band / Channel BW / N <sub>RB</sub> / Duplex mode			
E-UTRA V2X band (PC5)	E-UTRA or V2X operating band (Uu)	E-UTRA or V2X UL band (Uu)	Channel Bandwidth (MHz)	N <sub>RB</sub>	Duplex Mode
47	3	3	10	50	FDD
47	5	5	10	50	FDD
47	7	7	10	50	FDD
47	8	8	10	50	FDD
47	20	20	10	50	FDD
47	28	28	10	50	FDD
47	34	34	10	50	TDD
47	39	39	10	50	TDD
47	41	41	10	50	TDD
47	71	71	10	50	FDD

Table 7.3.1G-4: Sidelink TX configuration for REFSSENS of E-UTRA V2X Bands

Inter-band E-UTRA V2X /E-UTRA configuration		E-UTRA UL band / Channel BW / N <sub>RB</sub> / Duplex mode			
E-UTRA V2X band (PC5)	E-UTRA or V2X operating band (Uu)	E-UTRA or V2X band (PC5)	Channel Bandwidth (MHz)	N <sub>RB</sub>	Duplex Mode
47	3	47	10	50	HD
47	5	47	10	50	HD
47	7	47	10	50	HD
47	8	47	10	50	HD
47	20	47	10	50	HD
47	28	47	10	50	HD
47	34	47	10	50	HD
47	39	47	10	50	HD
47	41	47	10	50	HD
47	71	47	10	50	HD

For intra-band contiguous multi-carrier operation, the reference sensitivity requirement specified in Table 7.3.1G-1 shall apply for each component carrier with all carriers active. The requirement is applied for multi-carrier intra-band concurrent receptions when 2 carrier transmissions are activated at the same time.

Table 7.3.1G-5: Sidelink TX configuration for REFSSENS of E-UTRA V2X Bands for intra-band multi-carrier operation

V2X configuration	50RB+50RB		100RB+50RB		Duplex Mode
	PCC	SCC	PCC	SCC	
V2X_47B	50	50	N/A	N/A	HD
V2X_47C	N/A	N/A	100	50	HD

### 7.3.2 Void

## 7.4 Maximum input level

This is defined as the maximum mean power received at the UE antenna port, at which the specified relative throughput shall meet or exceed the minimum requirements for the specified reference measurement channel.



## 7.4.1 Minimum requirements

The throughput shall be  $\geq 95\%$  of the maximum throughput of the reference measurement channels as specified in Annexes A.2.2, A.2.3 and A.3.2 (with one sided dynamic OCNG Pattern OP.1 FDD/TDD as described in Annex A.5.1.1/A.5.2.1) with parameters specified in Table 7.4.1-1. For operating bands with an unpaired DL part (as noted in Table 5.5-1), the requirements only apply for carriers assigned in the paired part.

**Table 7.4.1-1: Maximum input level**

Rx Parameter	Units	Channel bandwidth					
		1.4 MHz	3 MHz	5 MHz	10 MHz	15 MHz	20 MHz
Power in Transmission Bandwidth Configuration	dBm	-25 <sup>2</sup>					
		-27 <sup>3</sup>					
		-27 <sup>4</sup>					
NOTE 1: The transmitter shall be set to 4dB below P <sub>CMAX,L</sub> at the minimum uplink configuration specified in Table 7.3.1-2 with P <sub>CMAX,L</sub> as defined in subclause 6.2.5.							
NOTE 2: Reference measurement channel is Annex A.3.2: 64QAM, R=3/4 variant with one sided dynamic OCNG Pattern OP.1 FDD/TDD as described in Annex A.5.1.1/A.5.2.1.							
NOTE 3: Reference measurement channel is Annex A.3.2: 256QAM, R=4/5 variant with one sided dynamic OCNG Pattern OP.1 FDD/TDD as described in Annex A.5.1.1/A.5.2.1.							
NOTE 4: Reference measurement channel is Annex A.3.2: 1024QAM, R=4/5 variant with one sided dynamic OCNG Pattern OP.1 FDD/TDD as described in Annex A.5.1.1/A.5.2.1.							

### 7.4.1A Minimum requirements for CA

For inter-band carrier aggregation with one component carrier per operating band and the uplink assigned to one E-UTRA band the maximum input level is defined with the uplink active on the band(s) other than the band whose downlink is being tested. For E-UTRA CA configurations including an operating band without uplink band or an operating band with an unpaired DL part, the requirements for all downlinks shall be met with the single uplink carrier active in each band capable of UL operation. The UE shall meet the requirements specified in subclause 7.4.1 for each component carrier while all downlink carriers are active.

For intra-band contiguous carrier aggregation maximum input level is defined as the powers received at the UE antenna port over the Transmission bandwidth configuration of each CC, at which the specified relative throughput shall meet or exceed the minimum requirements for the specified reference measurement channel over each component carrier.

The downlink SCC(s) shall be configured at nominal channel spacing to the PCC. For FDD the PCC shall be configured closest to the uplink band. All downlink carriers shall be active throughout the test. The uplink output power shall be set as specified in Table 7.4.1A-1 with the uplink configuration set according to Table 7.3.1A-1 for the applicable carrier aggregation configuration. For UE(s) supporting one uplink carrier, the uplink configuration of the PCC shall be in accordance with Table 7.3.1-2.

The throughput shall be  $\geq 95\%$  of the maximum throughput of the reference measurement channels over each component carrier as specified in Annexes A.2.2, A.2.3 and A.3.2 (with one sided dynamic OCNG Pattern OP.1 FDD/TDD as described in Annex A.5.1.1/A.5.2.1) with parameters specified in Table 7.4.1A-1. For operating bands with an unpaired DL part (as noted in Table 5.5-1), the requirements also apply for an SCC assigned in the unpaired part with parameters specified in Table 7.4.1A-1.

For intra-band non-contiguous carrier aggregation with one uplink carrier and two or more downlink sub-blocks, each larger than or equal to 5 MHz, the maximum input level requirements are defined with the uplink configuration in accordance with Table 7.3.1A-3. For this uplink configuration, the UE shall meet the requirements for each sub-block as specified in Table 7.4.1-1 and Table 7.4.1A-1 for one component carrier and two component carriers per sub-block, respectively. The throughput of each downlink component carrier shall be  $\geq 95\%$  of the maximum throughput of the specified reference measurement channel as specified in Annexes A.2.2, A.2.3 and A.3.2 (with one sided dynamic OCNG Pattern OP.1 FDD/TDD as described in Annex A.5.1.1/A.5.2.1). The requirements apply with all downlink carriers active.

**Table 7.4.1A-1: Maximum input level for intra-band contiguous CA**

Rx Parameter	Units	CA Bandwidth Class					
		A	B	C	D	E	F
Power in largest Transmission Bandwidth Configuration CC	dBm		-28 <sup>2</sup>	-25 <sup>2</sup>	-25 <sup>2</sup>	-26 <sup>2</sup>	-27 <sup>2</sup>
			-30 <sup>3</sup>	-27 <sup>3</sup>	-27 <sup>3</sup>	[-28] <sup>3</sup>	[-29] <sup>3</sup>
			-30 <sup>4</sup>	-27 <sup>4</sup>	-27 <sup>4</sup>	[-28] <sup>4</sup>	[-29] <sup>4</sup>
Power in each other CC	dBm		-28 + $10\log(N_{RB,c} / N_{RB,largest\ BW})^2$	-25 + $10\log(N_{RB,c} / N_{RB,largest\ BW})^2$	-25 + $10\log(N_{RB,c} / N_{RB,largest\ BW})^2$	-26 + $10\log(N_{RB,c} / N_{RB,largest\ BW})^2$	-27 + $10\log(N_{RB,c} / N_{RB,largest\ BW})^2$
			-30 + $10\log(N_{RB,c} / N_{RB,largest\ BW})^3$	-27 + $10\log(N_{RB,c} / N_{RB,largest\ BW})^3$	-27 + $10\log(N_{RB,c} / N_{RB,largest\ BW})^3$	[-28] + $10\log(N_{RB,c} / N_{RB,largest\ BW})^3$	[-29] + $10\log(N_{RB,c} / N_{RB,largest\ BW})^3$
			-30 + $10\log(N_{RB,c} / N_{RB,largest\ BW})^4$	-27 + $10\log(N_{RB,c} / N_{RB,largest\ BW})^4$	-27 + $10\log(N_{RB,c} / N_{RB,largest\ BW})^4$	[-28] + $10\log(N_{RB,c} / N_{RB,largest\ BW})^4$	[-29] + $10\log(N_{RB,c} / N_{RB,largest\ BW})^4$
NOTE 1: The transmitter shall be set to 4dB below P <sub>CMAX,L,c</sub> or P <sub>CMAX,L</sub> as defined in subclause 6.2.5A.							
NOTE 2: Reference measurement channel is Annex A.3.2: 64QAM, R=3/4 variant with one sided dynamic OCNG Pattern OP.1 FDD/TDD as described in Annex A.5.1.1/A.5.2.1.							
NOTE 3: Reference measurement channel is Annex A.3.2: 256QAM, R=4/5 variant with one sided dynamic OCNG Pattern OP.1 FDD/TDD as described in Annex A.5.1.1/A.5.2.1.							
NOTE 4: Reference measurement channel is Annex A.3.2: 1024QAM, R=4/5 variant with one sided dynamic OCNG Pattern OP.1 FDD/TDD as described in Annex A.5.1.1/A.5.2.1.							

For combinations of intra-band and inter-band carrier aggregation and one uplink assigned to one E-UTRA band, the requirement is defined with the uplink active in a band other than that supporting the downlink(s) under test. The uplink configuration shall be in accordance with Table 7.3.1A-3 when the uplink is active in the band supporting two or more non-contiguous component carriers, Table 7.3.1A-1 when the uplink is active in a band supporting two contiguous component carriers and in accordance with Table 7.3.1-2 when the uplink is active in a band supporting one carrier per band. The downlink PCC shall be configured closer to the uplink operating band than the downlink SCC(s) when the uplink is active in band(s) supporting contiguous aggregation. For these uplink configurations, the UE shall meet the maximum input-level requirements for intra-band non-contiguous carrier aggregation of two or more downlink sub-blocks, the requirements for intra-band contiguous carrier aggregation for the contiguously aggregated downlink carriers and for any remaining component carrier(s) the requirements specified in subclause 7.4.1. All downlink carriers shall be active throughout the tests and the requirements for the downlinks shall be met with the single uplink carrier active in each band capable of UL operation.

### 7.4.1B Minimum requirements for UL-MIMO

For UE with two transmitter antenna connectors in closed-loop spatial multiplexing, the minimum requirements in Clause 7.4.1 shall be met with the UL-MIMO configurations specified in Table 6.2.2B-2. For UL-MIMO, the parameter P<sub>CMAX,L</sub> is defined as the total transmitter power over the two transmit antenna connectors.

### 7.4.1D Minimum requirements for ProSe

The throughput shall be ≥ 95% of the maximum throughput of the reference measurement channels as specified in Annexes A.6.2.

**Table 7.4.1D-1: Maximum input level for ProSe**

Rx Parameter	Units	Channel bandwidth					
		1.4 MHz	3 MHz	5 MHz	10 MHz	15 MHz	20 MHz
Power in Transmission Bandwidth Configuration	dBm	-22					
NOTE 1: Reference measurement channel is Annex A.6.2							

## 7.4.1F Minimum requirements for category NB1 and NB2

Category NB1 and NB2 UE maximum input level requirement is – 25 dBm. For this input level the throughput shall be  $\geq 95\%$  of the maximum throughput of the reference measurement channel as specified in Annex A.3.2.

## 7.4.1G Minimum requirements for V2X

The throughput shall be  $\geq 95\%$  of the maximum throughput of the reference measurement channels as specified in Annexes A.8.2 with parameters specified in Table 7.4.1G-1.

**Table 7.4.1G-1: Maximum input level**

Rx Parameter	Units	Channel bandwidth					
		1.4 MHz	3 MHz	5 MHz	10 MHz	15 MHz	20 MHz
Power in Transmission Bandwidth Configuration	dBm				-22 <sup>2</sup>		-22 <sup>2</sup>
					-23 <sup>3</sup>		-23 <sup>3</sup>

NOTE 1: Reference measurement channel is defined in Annex A.8.2.  
NOTE 2: This requirement is applicable for 16QAM.  
NOTE 3: This requirement is applicable for 64QAM.

When UE is configured for simultaneous E-UTRA V2X sidelink and E-UTRA downlink reception for inter-band E-UTRA V2X / E-UTRA bands specified in Table 5.5G-2, the requirements in subclause 7.4.1G apply for the E-UTRA V2X sidelink reception and the requirements in subclause 7.4.1 apply for the E-UTRA downlink reception while all downlink carriers are active.

For intra-band contiguous multi-carrier operation, maximum input level is defined as the powers received at the UE antenna port over the Transmission bandwidth configuration of each CC, at which the specified relative throughput shall meet or exceed the minimum requirements for the specified reference measurement channel over each component carrier.

**Table 7.4.1G-2: Maximum input level for intra-band contiguous multi-carrier for V2X UE**

Rx Parameter	Units	V2X Bandwidth Class					
		A	B	C/C <sub>1</sub>	D	E	F
Power in largest Transmission Bandwidth Configuration CC	dBm		-22 <sup>2</sup>	-22 <sup>2</sup>			
			-23 <sup>3</sup>	-23 <sup>3</sup>			
Power in each other CC	dBm		-22+ $10\log(N_{RB,c} / N_{RB,largest\ BW})^2$	-22 <sup>2</sup> + $10\log(N_{RB,c} / N_{RB,largest\ BW})^2$			
			-23+ $10\log(N_{RB,c} / N_{RB,largest\ BW})^3$	-23+ $10\log(N_{RB,c} / N_{RB,largest\ BW})^3$			

NOTE 1: Void  
NOTE 2: The requirement is applied for multi-carrier intra-band con-current receptions when 2 carrier transmissions are activated at the same time.  
NOTE 3: This requirement is applicable for 64QAM.

## 7.4A Void

### 7.4A.1 Void

## 7.5 Adjacent Channel Selectivity (ACS)

Adjacent Channel Selectivity (ACS) is a measure of a receiver's ability to receive a E-UTRA signal at its assigned channel frequency in the presence of an adjacent channel signal at a given frequency offset from the centre frequency of the assigned channel. ACS is the ratio of the receive filter attenuation on the assigned channel frequency to the receive filter attenuation on the adjacent channel(s).

### 7.5.1 Minimum requirements

The UE shall fulfil the minimum requirement specified in Table 7.5.1-1 for all values of an adjacent channel interferer up to  $-25$  dBm. However it is not possible to directly measure the ACS, instead the lower and upper range of test parameters are chosen in Table 7.5.1-2 and Table 7.5.1-3 where the throughput shall be  $\geq 95\%$  of the maximum throughput of the reference measurement channels as specified in Annexes A.2.2, A.2.3 and A.3.2 (with one sided dynamic OCNG Pattern OP.1 FDD/TDD for the DL-signal as described in Annex A.5.1.1/A.5.2.1). For operating bands with an unpaired DL part (as noted in Table 5.5-1), the requirements only apply for carriers assigned in the paired part.

**Table 7.5.1-1: Adjacent channel selectivity**

Rx Parameter	Units	Channel bandwidth					
		1.4 MHz	3 MHz	5 MHz	10 MHz	15 MHz	20 MHz
ACS	dB	33.0	33.0	33.0	33.0	30	27

**Table 7.5.1-2: Test parameters for Adjacent channel selectivity, Case 1**

Rx Parameter	Units	Channel bandwidth					
		1.4 MHz	3 MHz	5 MHz	10 MHz	15 MHz	20 MHz
Power in Transmission Bandwidth Configuration	dBm	REFSENS + 14 dB					
$P_{\text{Interferer}}$	dBm	REFSENS +45.5dB	REFSENS +45.5dB	REFSENS +45.5dB	REFSENS +45.5dB	REFSENS +42.5dB	REFSENS +39.5dB
$BW_{\text{Interferer}}$	MHz	1.4	3	5	5	5	5
$F_{\text{Interferer}} \text{ (offset)}$	MHz	1.4+0.0025 / -1.4-0.0025	3+0.0075 / -3-0.0075	5+0.0025 / -5-0.0025	7.5+0.0075 / -7.5-0.0075	10+0.0125 / -10-0.0125	12.5+0.0025 / -12.5-0.0025
NOTE 1: The transmitter shall be set to 4dB below $P_{\text{CMAX,L}}$ at the minimum uplink configuration specified in Table 7.3.1-2 with $P_{\text{CMAX,L}}$ as defined in subclause 6.2.5.							
NOTE 2: The interferer consists of the Reference measurement channel specified in Annex A.3.2 with one sided dynamic OCNG Pattern OP.1 FDD/TDD as described in Annex A.5.1.1/A.5.2.1 and set-up according to Annex C.3.1.							
NOTE 3: The REFSENS power level is specified in Table 7.3.1-1 and Table 7.3.1-1a for two and four antenna ports, respectively.							
NOTE 4: For DL category M1 and M2 UE, the reference sensitivity for category M1 in table 7.3.1E-3 and category M2 in Table 7.3.1E-8 should be used as REFSENS for the power in Transmission Bandwidth Configuration and $P_{\text{Interferer}}$ .							
NOTE5: For DL category M1 and M2 UE, the parameters for the applicable channel bandwidth apply.							

Table 7.5.1-3: Test parameters for Adjacent channel selectivity, Case 2

Rx Parameter	Units	Channel bandwidth					
		1.4 MHz	3 MHz	5 MHz	10 MHz	15 MHz	20 MHz
Power in Transmission Bandwidth Configuration	dBm	-56.5	-56.5	-56.5	-56.5	-53.5	-50.5
$P_{\text{Interferer}}$	dBm	-25					
$BW_{\text{Interferer}}$	MHz	1.4	3	5	5	5	5
$F_{\text{Interferer}}$ (offset)	MHz	1.4+0.0025 / -1.4-0.0025	3+0.0075 / -3-0.0075	5+0.0025 / -5-0.0025	7.5+0.0075 / -7.5-0.0075	10+0.0125 / -10-0.0125	12.5+0.0025 / -12.5-0.0025
NOTE 1: The transmitter shall be set to 24dB below $P_{\text{CMAX,L}}$ at the minimum uplink configuration specified in Table 7.3.1-2 with $P_{\text{CMAX,L}}$ as defined in subclause 6.2.5.							
NOTE 2: The interferer consists of the Reference measurement channel specified in Annex 3.2 with one sided dynamic OCNG Pattern OP.1 FDD/TDD as described in Annex A.5.1.1/A.5.2.1 and set-up according to Annex C.3.1.							

### 7.5.1A Minimum requirements for CA

For inter-band carrier aggregation with one component carrier per operating band and the uplink assigned to one E-UTRA band, the adjacent channel requirements are defined with the uplink active on the band(s) other than the band whose downlink is being tested. The UE shall meet the requirements specified in subclause 7.5.1 for each component carrier while all downlink carriers are active. For E-UTRA CA configurations including an operating band without uplink operation or an operating band with an unpaired DL part (as noted in Table 5.5-1), the requirements for all downlinks shall be met with the single uplink carrier active in each band capable of UL operation. For a component carrier configured in Band 46 or Band 49, the requirements specified in subclause 7.5.1 are replaced by the requirements in Table 7.5.1A-0a with test parameters in Table 7.5.1A-0b and Table 7.5.1A-0c.

Table 7.5.1A-0a: Adjacent channel selectivity

E-UTRA band	Rx Parameter	Units	Channel bandwidth					
			1.4 MHz	3 MHz	5 MHz	10 MHz	15 MHz	20 MHz
46	ACS	dB				33		27
49	ACS	dB				33		33

Table 7.5.1A-0b: Test parameters for Adjacent channel selectivity, Case 1

E-UTRA Band	Rx Parameter	Units	Channel bandwidth					
			1.4 MHz	3 MHz	5 MHz	10 MHz	15 MHz	20 MHz
46	Power in Transmission Bandwidth Configuration	dBm	REFSENS + 14 dB					
	$P_{\text{interferer}}$	dBm				REFSENS+45.5dB		REFSENS +39.5dB
	$BW_{\text{interferer}}$	MHz				20		20
	$F_{\text{interferer}}$ (offset)	MHz				15+0.0075/-15-0.0075		20+0.0025 / -20-0.0025
49	Power in Transmission Bandwidth Configuration	dBm	REFSENS + 14 dB					
	$P_{\text{interferer}}$	dBm				REFSENS+45.5dB		REFSENS+45.5dB
	$BW_{\text{interferer}}$	MHz				10		20
	$F_{\text{interferer}}$ (offset)	MHz				10+0.0125 / -10-0.0125		20+0.0025 / -20-0.0025
NOTE 1: In a band capable of uplink operation, the transmitter shall be set to 4dB below $P_{\text{CMAX,L}}$ at the minimum uplink configuration specified in Table 7.3.1-2 with $P_{\text{CMAX,L}}$ as defined in subclause 6.2.5.								
NOTE 2: The interferer consists of the Reference measurement channel specified in Annex A.3.2 with one sided dynamic OCNB Pattern OP.1 FDD/TDD/FS3 as described in Annex A.5.1.1/A.5.2.1/A.5.4.1 and set-up according to Annex C.3.1.								

Table 7.5.1A-0c: Test parameters for Adjacent channel selectivity, Case 2

E-UTRA band	Rx Parameter	Units	Channel bandwidth					
			1.4 MHz	3 MHz	5 MHz	10 MHz	15 MHz	20 MHz
46	Power in Transmission Bandwidth Configuration	dBm				-56.5		-50.5
	$P_{\text{interferer}}$	dBm	-25					
	$BW_{\text{interferer}}$	MHz				20		20
	$F_{\text{interferer}}$ (offset)	MHz				15+0.0075/-15-0.0075		20+0.0025 / -20-0.0025
49	Power in Transmission Bandwidth Configuration					-56.5		-56.5
	$P_{\text{interferer}}$		-25					
	$BW_{\text{interferer}}$					10		20
	$F_{\text{interferer}}$ (offset)					10+0.0125 / -10-0.0125		20+0.0025 / -20-0.0025
NOTE 1: In a band capable of uplink operation, the transmitter shall be set to 24dB below $P_{\text{CMAX,L}}$ at the minimum uplink configuration specified in Table 7.3.1-2 with $P_{\text{CMAX,L}}$ as defined in subclause 6.2.5.								
NOTE 2: The interferer consists of the Reference measurement channel specified in Annex A.3.2 with one sided dynamic OCNB Pattern OP.1 FDD/TDD/FS3 as described in Annex A.5.1.1/A.5.2.1/A.5.4.1 and set-up according to Annex C.3.1.								

For E-UTRA CA configurations listed in Table 7.3.1A-0a under conditions for which reference sensitivity for the operating band being tested is N/A, the adjacent channel requirements of subclause 7.5.1A do not apply.

For intra-band contiguous carrier aggregation the downlink SCC(s) shall be configured at nominal channel spacing to the PCC. For FDD, the PCC shall be configured closest to the uplink band. All downlink carriers shall be active

throughout the test. The uplink output power shall be set as specified in Table 7.5.1A-2 and Table 7.5.1A-3 with the uplink configuration set according to Table 7.3.1A-1 for the applicable carrier aggregation configuration. For UE(s) supporting one uplink carrier, the uplink configuration of the PCC shall be in accordance with Table 7.3.1-2. The UE shall fulfil the minimum requirement specified in Table 7.5.1A-1 for an adjacent channel interferer on either side of the aggregated downlink signal at a specified frequency offset and for an interferer power up to -25 dBm. The throughput of each carrier shall be  $\geq 95\%$  of the maximum throughput of the reference measurement channels as specified in Annexes A.2.2, A.2.3 and A.3.2 (with one sided dynamic OCNG Pattern OP.1 FDD/TDD for the DL-signal as described in Annex A.5.1.1/A.5.2.1) with parameters specified in Tables 7.5.1A-2 and 7.5.1A-3. For operating bands with an unpaired DL part (as noted in Table 5.5-1), the requirements also apply for an SCC assigned in the unpaired part with parameters specified in Tables 7.5.1A-2 and 7.5.1A-3.

For intra-band non-contiguous carrier aggregation with one uplink carrier and two or more downlink sub-blocks, each larger than or equal to 5 MHz, the adjacent channel selectivity requirements are defined with the uplink configuration in accordance with Table 7.3.1A-3. For this uplink configuration, the UE shall meet the requirements for each sub-block as specified in subclauses 7.5.1 and 7.5.1A for one component carrier and two component carriers per sub-block, respectively. The UE shall fulfil the minimum requirements all values of a single adjacent channel interferer in-gap and out-of-gap up to a -25 dBm interferer power while all downlink carriers are active. For the lower range of test parameters (Case 1), the interferer power  $P_{\text{interferer}}$  shall be set to the maximum of the levels given by the carriers of the respective sub-blocks as specified in Table 7.5.1-2 and Table 7.5.1A-2 for one component carrier and two component carriers per sub-block, respectively. The wanted signal power levels for the carriers of each sub-block shall then be adjusted relative to  $P_{\text{interferer}}$  in accordance with the ACS requirement for each sub-block (Table 7.5.1-1 and Table 7.5.1A-1). For the upper range of test parameters (Case 2) for which the interferer power  $P_{\text{interferer}}$  is -25 dBm (Table 7.5.1-3 and Table 7.5.1A-3) the wanted signal power levels for the carriers of each sub-block shall be adjusted relative to  $P_{\text{interferer}}$  like for Case 1.

**Table 7.5.1A-1: Adjacent channel selectivity**

Rx Parameter	Units	CA Bandwidth Class				
		B	C	D	E	F
ACS	dB	27	24	22.2	21	20

**Table 7.5.1A-2: Test parameters for Adjacent channel selectivity, Case 1**

Rx Parameter	Units	CA Bandwidth Class				
		B	C	D	E	F
$P_w$ in Transmission Bandwidth Configuration, per CC		REFSENS + 14 dB	REFSENS + 14 dB	REFSENS + 14 dB	REFSENS + 14 dB	REFSENS + 14 dB
$P_{\text{interferer}}$	dBm	Aggregated power + 25.5 dB	Aggregated power + 22.5 dB	Aggregated power + 20.7 dB	Aggregated power + 19.5 dB	Aggregated power + 18.5 dB
$BW_{\text{interferer}}$	MHz	5	5	5	5	5
$F_{\text{interferer}}$ (offset)	MHz	$2.5 + F_{\text{offset}}$ / $-2.5 - F_{\text{offset}}$	$2.5 + F_{\text{offset}}$ / $-2.5 - F_{\text{offset}}$	$2.5 + F_{\text{offset}}$ / $-2.5 - F_{\text{offset}}$	$2.5 + F_{\text{offset}}$ / $-2.5 - F_{\text{offset}}$	$2.5 + F_{\text{offset}}$ / $-2.5 - F_{\text{offset}}$
NOTE 1: The transmitter shall be set to 4dB below $P_{\text{CMAX\_L,C}}$ or $P_{\text{CMAX\_L}}$ as defined in subclause 6.2.5A.						
NOTE 2: The interferer consists of the Reference measurement channel specified in Annex A.3.2 with one sided dynamic OCNG Pattern OP.1 FDD/TDD as described in Annex A.5.1.1/A.5.2.1 and set-up according to Annex C.3.1						
NOTE 3: The $F_{\text{interferer}}$ (offset) is the frequency separation of the center frequency of the carrier closest to the interferer and the center frequency of the adjacent channel interferer and shall be further adjusted to $\lfloor F_{\text{interferer}} / 0.015 + 0.5 \rfloor \cdot 0.015 + 0.0075$ MHz to be offset from the sub-carrier raster.						

Table 7.5.1A-3: Test parameters for Adjacent channel selectivity, Case 2

Rx Parameter	Units	CA Bandwidth Class				
		B	C	D	E	F
Pw in Transmission Bandwidth Configuration, per CC	dBm	$-50.5 + 10 \log_{10} \left( \frac{N_{RB,c}}{N_{RB,agg}} \right)$	$-47.5 + 10 \log_{10} \left( \frac{N_{RB,c}}{N_{RB,agg}} \right)$	$45.7 + 10 \log_{10} \left( \frac{N_{RB,c}}{N_{RB,agg}} \right)$	$-44.5 + 10 \log_{10} \left( \frac{N_{RB,c}}{N_{RB,agg}} \right)$	$-43.5 + 10 \log_{10} \left( \frac{N_{RB,c}}{N_{RB,agg}} \right)$
$P_{Interferer}$	dBm	-25				
$BW_{Interferer}$	MHz	5	5	5	5	5
$F_{Interferer}$ (offset)	MHz	$2.5 + F_{offset}$ / $-2.5 - F_{offset}$	$2.5 + F_{offset}$ / $-2.5 - F_{offset}$	$2.5 + F_{offset}$ / $-2.5 - F_{offset}$	$2.5 + F_{offset}$ / $-2.5 - F_{offset}$	$2.5 + F_{offset}$ / $-2.5 - F_{offset}$
NOTE 1: The transmitter shall be set to 24dB below $P_{CMAX,L,c}$ or $P_{CMAX,L}$ as defined in subclause 6.2.5A.						
NOTE 2: The interferer consists of the Reference measurement channel specified in Annex 3.2 with one sided dynamic OCNB Pattern OP.1 FDD/TDD as described in Annex A.5.1.1/A.5.2.1 and set-up according to Annex C.3.1						
NOTE 3: The $F_{Interferer}$ (offset) is the frequency separation of the center frequency of the carrier closest to the interferer and the center frequency of the adjacent channel interferer and shall be further adjusted to $\lfloor \frac{F_{Interferer}}{0.015 + 0.5} \rfloor \cdot 0.015 + 0.0075$ MHz to be offset from the sub-carrier raster.						

For combinations of intra-band and inter-band carrier aggregation and one uplink carrier assigned to one E-UTRA band, the requirement is defined with the uplink active in each band other than that supporting the downlink(s) under test. The uplink configuration shall be in accordance with Table 7.3.1A-3 when the uplink is active in the band supporting two or more non-contiguous component carriers, Table 7.3.1A-1 when the uplink is active in a band supporting two contiguous component carriers and in accordance with Table 7.3.1-2 when the uplink is active in a band supporting one carrier per band. The downlink PCC shall be configured closer to the uplink operating band than the downlink SCC(s) when the uplink is active in band(s) supporting contiguous aggregation. For these uplink configurations, the UE shall meet the adjacent channel selectivity requirements for intra-band non-contiguous carrier aggregation with  $\Delta R_{IBNC} = 0$  dB for all sub-block gaps (Table 7.3.1A-3) for the two or more non-contiguous downlink sub-blocks, the requirements for intra-band contiguous carrier aggregation for the contiguously aggregated downlink carriers and for any remaining component carrier(s) the requirements specified in subclause 7.5.1. For contiguously aggregated component carriers configured in Band 46, the said requirements for intra-band contiguous carrier aggregation of downlink carriers are replaced by requirements in Table 7.5.1A-4 with test parameters in Table 7.5.1A-5 and Table 7.5.1A-6. For non-contiguously aggregated component carriers configured in Band 46, the said requirements are applied to each sub-block for in-gap and out-of-gap interferers. For the sub-block with a single component carrier, the requirement is replaced by Table 7.5.1A-0a with test parameters in Table 7.5.1A-0b and Table 7.5.1A-0c. For the sub-block with two or more contiguous component carriers, the requirement is replaced by Table 7.5.1A-4 with test parameters in Table 7.5.1A-5 and Table 7.5.1A-6. All downlink carriers shall be active throughout the tests and the requirements for downlinks shall be met with the single uplink carrier active in each band capable of UL operation.

Table 7.5.1A-4: Adjacent channel selectivity

E-UTRA band	Rx Parameter	Units	CA Bandwidth Class				
			B	C	D	E	F
46	ACS	dB		24	22.2	21	



Table 7.5.1A-5: Test parameters for Adjacent channel selectivity, Case 1

E-UTRA Band	Rx Parameter	Units	CA Bandwidth Class				
			B	C	D	E	F
46	Pw in Transmission Bandwidth Configuration, per CC			REFSENS + 14 dB	REFSENS + 14 dB	REFSENS + 14 dB	
	P <sub>Interferer</sub>	dBm		Aggregate d power + 22.5 dB	Aggregate d power + 20.7 dB	Aggregate d power + 19.5 dB	
	BW <sub>Interferer</sub>	MHz		20	20	20	
	F <sub>Interferer (offset)</sub>	MHz		$10 + F_{\text{offset}} / -10 - F_{\text{offset}}$	$10 + F_{\text{offset}} / -10 - F_{\text{offset}}$	$10 + F_{\text{offset}} / -10 - F_{\text{offset}}$	
NOTE 1*: In a band capable of uplink operation, the transmitter shall be set to 4dB below P <sub>CMAX,L,c</sub> or P <sub>CMAX,L</sub> as defined in subclause 6.2.5A.							
NOTE 2: The interferer consists of the Reference measurement channel specified in Annex A.3.2 with one sided dynamic OCNG Pattern OP.1 FDD/TDD/FS3 as described in Annex A.5.1.1/A.5.2.1/A.5.4.1 and set-up according to Annex C.3.1.							
NOTE 3: The F <sub>Interferer (offset)</sub> is the frequency separation of the center frequency of the carrier closest to the interferer and the center frequency of the adjacent channel interferer and shall be further adjusted to $\lfloor F_{\text{interferer}} / 0.015 + 0.5 \rfloor 0.015 + 0.0075$ MHz to be offset from the sub-carrier raster.							

Table 7.5.1A-6: Test parameters for Adjacent channel selectivity, Case 2

E-UTRA band	Rx Parameter	Units	CA Bandwidth Class				
			B	C	D	E	F
46	Pw in Transmission Bandwidth Configuration, per CC	dBm		-47.5 $+10\log_{10}(N_{\text{RB}}/N_{\text{RB agg}})$	-45.7 $+10\log_{10}(N_{\text{RB.c}}/N_{\text{RB agg}})$	-44.5 $+10\log_{10}(N_{\text{RB.c}}/N_{\text{RB agg}})$	
	P <sub>Interferer</sub>	dBm		-25			
	BW <sub>Interferer</sub>	MHz		20	20	20	
	F <sub>Interferer (offset)</sub>	MHz		$10 + F_{\text{offset}} / -10 - F_{\text{offset}}$	$10 + F_{\text{offset}} / -10 - F_{\text{offset}}$	$10 + F_{\text{offset}} / -10 - F_{\text{offset}}$	
NOTE 1: In a band capable of uplink operation, the transmitter shall be set to 24dB below P <sub>CMAX,L,c</sub> or P <sub>CMAX,L</sub> as defined in subclause 6.2.5A.							
NOTE 2: The interferer consists of the Reference measurement channel specified in Annex 3.2 with one sided dynamic OCNG Pattern OP.1 FDD/TDD/FS3 as described in Annex A.5.1.1/A.5.2.1/A.5.4.1 and set-up according to Annex C.3.1.							
NOTE 3: The F <sub>Interferer (offset)</sub> is the frequency separation of the center frequency of the carrier closest to the interferer and the center frequency of the adjacent channel interferer and shall be further adjusted to $\lfloor F_{\text{interferer}} / 0.015 + 0.5 \rfloor 0.015 + 0.0075$ MHz to be offset from the sub-carrier raster.							

## 7.5.1B Minimum requirements for UL-MIMO

For UE(s) with two transmitter antenna connectors in closed-loop spatial multiplexing scheme, the minimum requirements in Clause 7.5.1 shall be met with the UL-MIMO configurations specified in Table 6.2.2B-2. For UL-MIMO, the parameter P<sub>CMAX,L</sub> is defined as the total transmitter power over the two transmit antenna connectors.

## 7.5.1D Minimum requirements for ProSe

The UE shall fulfil the minimum requirement specified in Table 7.5.1D-1 for all values of an adjacent channel interferer up to -25 dBm. However it is not possible to directly measure the ACS, instead the lower and upper range of test parameters are chosen in Table 7.5.1D-2 and Table 7.5.1D-3 where the throughput shall be  $\geq 95\%$  of the maximum throughput of the reference measurement channels as specified in Annex A.6.2.

Table 7.5.1D-1: Adjacent channel selectivity for ProSe

Rx Parameter	Units	Channel bandwidth					
		1.4 MHz	3 MHz	5 MHz	10 MHz	15 MHz	20 MHz
ACS	dB			33.0	33.0	30	27

Table 7.5.1D-2: Test parameters for Adjacent channel selectivity for ProSe, Case 1

Rx Parameter	Units	Channel bandwidth					
		1.4 MHz	3 MHz	5 MHz	10 MHz	15 MHz	20 MHz
Power in Transmission Bandwidth Configuration	dBm	P <sub>REFSENS_ProSe</sub> + 14 dB					
P <sub>Interferer</sub>	dBm			REFSENS +45.5dB	REFSENS +45.5dB	REFSENS +42.5dB	REFSENS +39.5dB
BW <sub>Interferer</sub>	MHz			5	5	5	5
F <sub>Interferer</sub> (offset)	MHz			5+0.0025 / -5-0.0025	7.5+0.0075 / -7.5-0.0075	10+0.0125 / -10-0.0125	12.5+0.0025 / -12.5-0.0025
NOTE 1: The interferer is QPSK modulated PUSCH containing data and reference symbols. Normal cyclic prefix is used. The data content shall be uncorrelated to the wanted signal and modulated according to clause 5 of TS36.211.							

Table 7.5.1D-3: Test parameters for Adjacent channel selectivity for ProSe, Case 2

Rx Parameter	Units	Channel bandwidth					
		1.4 MHz	3 MHz	5 MHz	10 MHz	15 MHz	20 MHz
Power in Transmission Bandwidth Configuration	dBm			-56.5	-56.5	-53.5	-50.5
P <sub>Interferer</sub>	dBm	-25					
BW <sub>Interferer</sub>	MHz			5	5	5	5
F <sub>Interferer</sub> (offset)	MHz			5+0.0025 / -5-0.0025	7.5+0.0075 / -7.5-0.0075	10+0.0125 / -10-0.0125	12.5+0.0025 / -12.5-0.0025
NOTE 1: The interferer is QPSK modulated PUSCH containing data and reference symbols. Normal cyclic prefix is used. The data content shall be uncorrelated to the wanted signal and modulated according to clause 5 of TS36.211.							

## 7.5.1F Minimum requirements for category NB1 and NB2

Category NB1 and NB2 UE shall fulfil the minimum requirement specified in Table 7.5.1F-1 for all values of an adjacent channel interferer up to -25 dBm. However it is not possible to directly measure the ACS, instead the lower and upper range of test parameters are chosen in Table 7.5.1F-1 where the throughput shall be  $\geq 95\%$  of the maximum throughput of the reference measurement channel as specified in Annex A.3.2.

**Table 7.5.1F: Adjacent channel selectivity parameters for category NB1 and NB2**

ACS1 test Parameters		
Interferer	GSM (GMSK)	E-UTRA
Category NB1 or NB2 signal power ( $P_{\text{wanted}}$ ) / dBm	REFSENS + 14 dB	
Interferer signal power ( $P_{\text{interferer}}$ ) / dBm	REFSENS + 42 dB	REFSENS + 47 dB
Interferer bandwidth	200 kHz	5 MHz
Interferer offset from category NB1 or NB2 channel edge	$\pm 200$ kHz	$\pm 2.5$ MHz
ACS2 test Parameters		
Interferer	GSM (GMSK)	E-UTRA
Category NB1 or NB2 signal power ( $P_{\text{wanted}}$ ) / dBm	-53 dBm	-58 dBm
Interferer signal power ( $P_{\text{interferer}}$ ) / dBm	-25 dBm	
Interferer bandwidth	200 kHz	5 MHz
Interferer offset from category NB1 or NB2 channel edge	$\pm 200$ kHz	$\pm 2.5$ MHz

## 7.5.1G Minimum requirements for V2X

The V2X UE shall fulfil the minimum requirement specified in Table 7.5.1G-1 for all values of an adjacent channel interferer up to -22 dBm. However it is not possible to directly measure the ACS, instead the lower and upper range of test parameters are chosen in Table 7.5.1G-2 and Table 7.5.1G-3 where the throughput shall be  $\geq 95\%$  of the maximum throughput of the reference measurement channels as specified in Annex A.8.2.

**Table 7.5.1G-1: Adjacent channel selectivity for V2X**

Rx Parameter	Units	Channel bandwidth					
		1.4 MHz	3 MHz	5 MHz	10 MHz	15 MHz	20 MHz
ACS	dB				33.0		27

**Table 7.5.1G-2: Test parameters for Adjacent channel selectivity for V2X, Case 1**

Rx Parameter	Units	Channel bandwidth					
		1.4 MHz	3 MHz	5 MHz	10 MHz	15 MHz	20 MHz
Power in Transmission Bandwidth Configuration	dBm	$P_{\text{REFSENS\_V2X}} + 14$ dB					
$P_{\text{Interferer}}$	dBm				$P_{\text{REFSENS\_V2X}} + 45.5$ dB		$P_{\text{REFSENS\_V2X}} + 39.5$ dB
$BW_{\text{Interferer}}$	MHz				10		10
$F_{\text{Interferer}}$ (offset)	MHz				$10+0.0125$ / $-10-0.0125$		$15+0.0075$ / $-15-0.0075$
NOTE 1: The interferer is QPSK modulated PUSCH containing data and reference symbols. Normal cyclic prefix is used. The data content shall be uncorrelated to the wanted signal and modulated according to clause 5 of TS36.211.							

**Table 7.5.1G-3: Test parameters for Adjacent channel selectivity for V2X, Case 2**

Rx Parameter	Units	Channel bandwidth					
		1.4 MHz	3 MHz	5 MHz	10 MHz	15 MHz	20 MHz
Power in Transmission Bandwidth Configuration	dBm				-53.5		-47.5
$P_{\text{Interferer}}$	dBm	-22					
$BW_{\text{Interferer}}$	MHz				10		10
$F_{\text{Interferer (offset)}}$	MHz				10+0.0125 / -10-0.0125		15+0.0075 / -15-0.0075
NOTE 1: The interferer is QPSK modulated PUSCH containing data and reference symbols. Normal cyclic prefix is used. The data content shall be uncorrelated to the wanted signal and modulated according to clause 5 of TS36.211.							

When UE is configured for simultaneous E-UTRA V2X sidelink and E-UTRA downlink reception for inter-band E-UTRA V2X / E-UTRA bands specified in Table 5.5G-2, the requirements in subclause 7.5.1G apply for the E-UTRA V2X sidelink reception and the requirements in subclause 7.5.1 apply for the E-UTRA downlink reception while all downlink carriers are active.

For intra-band contiguous multi-carrier operation, the V2X UE shall fulfil the minimum requirement specified in Table 7.5.1G-4 to Table 7.5.1G-6 where the throughput shall be  $\geq 95\%$  of the maximum throughput of the reference measurement channels as specified in Annex A.8.2.

**Table 7.5.1G-4: Adjacent channel selectivity for intra-band contiguous multi-carrier for V2X UE**

Rx Parameter	Units	V2X Bandwidth Class				
		B	C/ C <sub>1</sub>	D	E	F
ACS	dB	30	24			

**Table 7.5.1G-5: Test parameters for Adjacent channel selectivity, Case 1**

Rx Parameter	Units	V2X Bandwidth Class				
		B	C/ C <sub>1</sub>	D	E	F
$P_w$ in Transmission Bandwidth Configuration, per CC		REFSENS + 14 dB	REFSENS + 14 dB			
$P_{\text{Interferer}}$	dBm	Aggregated power + 28.5 dB	Aggregated power + 22.5 dB			
$BW_{\text{Interferer}}$	MHz	10	10			
$F_{\text{Interferer (offset)}}$	MHz	5 + $F_{\text{offset}}$ / -5 - $F_{\text{offset}}$	5 + $F_{\text{offset}}$ / -5 - $F_{\text{offset}}$			
NOTE 1: The $F_{\text{Interferer (offset)}}$ is the frequency separation of the center frequency of the carrier closest to the interferer and the center frequency of the adjacent channel interferer and shall be further adjusted to $\lfloor F_{\text{interferer}} / 0.015 + 0.5 \rfloor \cdot 0.015 + 0.0075$ MHz to be offset from the sub-carrier raster.						
NOTE 2: The requirement is applied for multi-carrier intra-band con-current receptions when 2 carrier transmissions are activated at the same time.						

Table 7.5.1G-6: Test parameters for Adjacent channel selectivity, Case 2

Rx Parameter	Units	V2X Bandwidth Class				
		B	C/ C <sub>1</sub>	D	E	F
P <sub>w</sub> in Transmission Bandwidth Configuration, per CC	dBm	-50.5 +10log <sub>10</sub> (N <sub>RB,c</sub> /N <sub>RB,agg</sub> )	-47.5 +10log <sub>10</sub> (N <sub>RB,c</sub> /N <sub>RB,agg</sub> )			
P <sub>Interferer</sub>	dBm	-22				
BW <sub>Interferer</sub>	MHz	10	10			
F <sub>Interferer</sub> (offset)	MHz	5+ F <sub>offset</sub> / -5- F <sub>offset</sub>	5+ F <sub>offset</sub> / -5- F <sub>offset</sub>			
NOTE 1: The F <sub>Interferer</sub> (offset) is the frequency separation of the center frequency of the carrier closest to the interferer and the center frequency of the adjacent channel interferer and shall be further adjusted to $\lfloor \frac{F_{\text{interferer}}}{0.015 + 0.5} \rfloor 0.015 + 0.0075$ MHz to be offset from the sub-carrier raster.						
NOTE 2: The requirement is applied for multi-carrier intra-band con-current receptions when 2 carrier transmissions are activated at the same time.						

## 7.6 Blocking characteristics

The blocking characteristic is a measure of the receiver's ability to receive a wanted signal at its assigned channel frequency in the presence of an unwanted interferer on frequencies other than those of the spurious response or the adjacent channels, without this unwanted input signal causing a degradation of the performance of the receiver beyond a specified limit. The blocking performance shall apply at all frequencies except those at which a spurious response occur.

### 7.6.1 In-band blocking

In-band blocking is defined for an unwanted interfering signal falling into the UE receive band or into the first 15 MHz below or above the UE receive band at which the relative throughput shall meet or exceed the minimum requirement for the specified measurement channels.

For CA configurations including Band 46, in-band blocking in Band 46 is defined for a 20 MHz unwanted interfering signal falling into the UE receive band or into the first 60 MHz below or above the UE receive band (Table 7.6.1.1A-0a and Table 7.6.1.1A-0b).

For CA configurations including Band 49, in-band blocking in Band 49 is defined for an unwanted interfering signal falling into the UE receive band or into the first 60 MHz below or above the UE receive band (Table 7.6.1.1A-0a and Table 7.6.1.1A-0b).

#### 7.6.1.1 Minimum requirements

The throughput shall be  $\geq 95\%$  of the maximum throughput of the reference measurement channels as specified in Annexes A.2.2, A.2.3 and A.3.2 (with one sided dynamic OCNG Pattern OP.1 FDD/TDD for the DL-signal as described in Annex A.5.1.1/A.5.2.1) with parameters specified in Tables 7.6.1.1-1 and 7.6.1.1-2. For operating bands with an unpaired DL part (as noted in Table 5.5-1), the requirements only apply for carriers assigned in the paired part.

Table 7.6.1.1-1: In band blocking parameters

Rx parameter	Units	Channel bandwidth					
		1.4 MHz	3 MHz	5 MHz	10 MHz	15 MHz	20 MHz
Power in Transmission Bandwidth Configuration	dBm	REFSENS + channel bandwidth specific value below					
		6	6	6	6	7	9
BW <sub>Interferer</sub>	MHz	1.4	3	5	5	5	5
F <sub>offset, case 1</sub>	MHz	2.1+0.0125	4.5+0.0075	7.5+0.0125	7.5+0.0025	7.5+0.0075	7.5+0.0125
F <sub>offset, case 2</sub>	MHz	3.5+0.0075	7.5+0.0075	12.5+0.0075	12.5+0.0125	12.5+0.0025	12.5+0.0075
NOTE 1: The transmitter shall be set to 4dB below P <sub>C<sub>MAX,L</sub></sub> at the minimum uplink configuration specified in Table 7.3.1-2 with P <sub>C<sub>MAX,L</sub></sub> as defined in subclause 6.2.5. NOTE 2: The interferer consists of the Reference measurement channel specified in Annex A.3.2 with one sided dynamic OCNG Pattern OP.1 FDD/TDD as described in Annex A.5.1.1/A.5.2.1 and set-up according to Annex C.3.1. NOTE 3: The REFSENS power level is specified in Table 7.3.1-1 and Table 7.3.1-1a for two and four antenna ports, respectively. NOTE 4: For DL category M1 and M2 UE, the reference sensitivity for category M1 in table 7.3.1E-3 and category M2 in Table 7.3.1E-8 should be used as REFSENS for the power in Transmission Bandwidth Configuration. NOTES: For DL category M1 and M2 UE, the parameters for the applicable channel bandwidth apply.							

Table 7.6.1.1-2: In-band blocking

E-UTRA band	Parameter	Unit	Case 1	Case 2	Case 3	Case 4	Case 5	Case 6
	P <sub>Interferer</sub>	dBm	-56	-44			-38	-15
	F <sub>Interferer (offset)</sub>	MHz	$\pm BW/2 - F_{offset, case 1}$ & $\pm BW/2 + F_{offset, case 1}$	$\leq -BW/2 - F_{offset, case 2}$ & $\geq +BW/2 + F_{offset, case 2}$			-BW/2 - 11	
1, 2, 3, 4, 5, 6, 7, 8, 9, 10, 11, 12, 13, 14, 17, 18, 19, 20, 21, 22, 23, 25, 26, 27, 28, 31, 33, 34, 35, 36, 37, 38, 39, 40, 41, 42, 43, 44, 45, 48, 50, 51, 52, 53, 65, 66, 68, 70, 72, 73, 74, 85, 87, 88	F <sub>Interferer</sub>	MHz	(NOTE 2)	F <sub>DL,low</sub> - 15 to F <sub>DL,high</sub> + 15	Void	Void		
30	F <sub>Interferer</sub>	MHz	(NOTE 2)	F <sub>DL,low</sub> - 15 to F <sub>DL,high</sub> + 15			F <sub>DL,low</sub> - 11	
71	F <sub>Interferer</sub>	MHz	(NOTE 2)	F <sub>DL,low</sub> - 12 to F <sub>DL,high</sub> + 15				F <sub>DL,low</sub> - 12
NOTE 1: For certain bands, the unwanted modulated interfering signal may not fall inside the UE receive band, but within the first 15 MHz below or above the UE receive band NOTE 2: For each carrier frequency the requirement is valid for two frequencies: a. the carrier frequency -BW/2 - F <sub>offset, case 1</sub> and b. the carrier frequency +BW/2 + F <sub>offset, case 1</sub> NOTE 3: F <sub>Interferer</sub> range values for unwanted modulated interfering signal are interferer center frequencies								

For the UE which supports inter band CA configuration in Table 7.3.1-1A, P<sub>Interferer</sub> power defined in Table 7.6.1.1-2 is increased by the amount given by ΔR<sub>IB,c</sub> in Table 7.3.1-1A.

7.6.1.1A Minimum requirements for CA

For inter-band carrier aggregation with one component carrier per operating band and the uplink assigned to one E-UTRA band the in-band blocking requirements are defined with the uplink active on the band(s) other than the band whose downlink is being tested. For adjacent downlink bands separated by less than 30 MHz the frequency separation between the center frequencies of adjacent component carriers belonging to different bands shall be  $\geq BW_1/2 + BW_2/2 + 2F_{\text{offset,case } j}$  for Case  $j$  interferers,  $j = 1, 2$ , where  $BW_k/2$  are the channel bandwidths of carrier  $k$ ,  $k = 1, 2$ . The UE shall meet the requirements specified in subclause 7.6.1.1 for each component carrier while all downlink carriers are active. For the UE which supports inter band CA configuration in Table 7.3.1-1A,  $P_{\text{interferer}}$  power defined in Table 7.6.1.1-2 is increased by the amount given by  $\Delta R_{\text{IB,c}}$  in Table 7.3.1-1A. For E-UTRA CA configurations including an operating band without uplink operation or an operating band with an unpaired DL part (as noted in Table 5.5-1), the requirements for all downlinks shall be met with the single uplink carrier active in each band capable of UL operation. The requirements for the component carrier configured in the operating band without uplink operation are specified in Table 7.6.1.1A-0, Table 7.6.1.1A-0a and Table 7.6.1.1A-0b. The requirements for a component carrier configured in Band 49 are specified in Table 7.6.1.1A-0a and Table 7.6.1.1A-0b.

Table 7.6.1.1A-0: In-band blocking for additional operating bands for carrier aggregation

E-UTRA band	Parameter	Unit	Case 1	Case 2
		$P_{\text{interferer}}$	dBm	-56
	$F_{\text{interferer}}$ (offset)	MHz	$= -BW/2 - F_{\text{offset,case } 1}$ & $= +BW/2 + F_{\text{offset,case } 1}$	$\leq -BW/2 - F_{\text{offset,case } 2}$ & $\geq +BW/2 + F_{\text{offset,case } 2}$
29, 32, 67, 69, 75, 76	$F_{\text{interferer}}$	MHz	(NOTE 2)	$F_{\text{DL,low}} - 15$ to $F_{\text{DL,high}} + 15$
NOTE 1: For certain bands, the unwanted modulated interfering signal may not fall inside the UE receive band, but within the first 15 MHz below or above the UE receive band				
NOTE 2: For each carrier frequency the requirement is valid for two frequencies: a. the carrier frequency $-BW/2 - F_{\text{offset,case } 1}$ and b. the carrier frequency $+BW/2 + F_{\text{offset,case } 1}$				
NOTE 3: $F_{\text{interferer}}$ range values for unwanted modulated interfering signal are interferer center frequencies				

Table 7.6.1.1A-0a: In band blocking parameters for additional operating bands for carrier aggregation

E-UTRA band	Rx parameter	Units	Channel bandwidth					
			1.4 MHz	3 MHz	5 MHz	10 MHz	15 MHz	20 MHz
46 (NOTE 3)	Power in Transmission Bandwidth Configuration	dBm	REFSENS + channel bandwidth specific value below					
	$BW_{\text{interferer}}$	MHz				6		9
	$F_{\text{offset,case } 1}$	MHz				20		20
	$F_{\text{offset,case } 2}$	MHz				30+0.0025		30+0.0125
		MHz				50+0.0125		50+0.0075
49 (NOTE 3)	Power in Transmission Bandwidth Configuration	dBm				6		6
	$BW_{\text{interferer}}$	MHz				10		20
	$F_{\text{offset,case } 1}$	MHz				15+0.025		30+0.125
	$F_{\text{offset,case } 2}$	MHz				25+0.075		50+0.075
NOTE 1: The transmitter shall be set to 4dB below $P_{\text{CMAX,L}}$ at the minimum uplink configuration specified in Table 7.3.1-2 with $P_{\text{CMAX,L}}$ as defined in subclause 6.2.5.								
NOTE 2: The interferer consists of the Reference measurement channel specified in Annex A.3.2 with one sided dynamic OCNG Pattern OP.1 FDD/TDD/FS3 as described in Annex A.5.1.1/A.5.2.1/A.5.4.1 and set-up according to Annex C.3.1								
NOTE 3: The interferer consists of the Reference measurement channel specified in Annex A.3.2 (TBD)								

Table 7.6.1.1A-0b: In-band blocking for additional operating bands for carrier aggregation

E-UTRA band	Parameter	Unit	Case 1	Case 2
		$P_{\text{Interferer}}$	dBm	-50
	$F_{\text{Interferer}}$ (offset)	MHz	$= -BW/2 - F_{\text{offset, case 1}}$ & $= +BW/2 + F_{\text{offset, case 1}}$	$\leq -BW/2 - F_{\text{offset, case 2}}$ & $\geq +BW/2 + F_{\text{offset, case 2}}$
46, 49	$F_{\text{Interferer}}$	MHz	(Note 2)	$F_{\text{DL, low}} - 60$ to $F_{\text{DL, high}} + 60$
<p>NOTE 1: For certain bands, the unwanted modulated interfering signal may not fall inside the UE receive band, but within the first 15 MHz or 60 MHz below or above the UE receive band</p> <p>NOTE 2: For each carrier frequency the requirement is valid for two frequencies: a. the carrier frequency <math>-BW/2 - F_{\text{offset, case 1}}</math> and b. the carrier frequency <math>+BW/2 + F_{\text{offset, case 1}}</math></p> <p>NOTE 3: <math>F_{\text{Interferer}}</math> range values for unwanted modulated interfering signal are interferer center frequencies</p>				

For E-UTRA CA configurations listed in Table 7.3.1A-0a under conditions for which reference sensitivity for the operating band being tested is N/A, the in-band blocking requirements of subclause 7.6.1.1A do not apply.

For intra-band contiguous carrier aggregation the downlink SCC(s) shall be configured at nominal channel spacing to the PCC. For FDD, the PCC shall be configured closest to the uplink band. All downlink carriers shall be active throughout the test. The uplink output power shall be set as specified in Table 7.6.1.1A-1 with the uplink configuration set according to Table 7.3.1A-1 for the applicable carrier aggregation configuration. For UE(s) supporting one uplink carrier, the uplink configuration of the PCC shall be in accordance with Table 7.3.1-2. The UE shall fulfil the minimum requirement in presence of an interfering signal specified in Tables 7.6.1.1A-1 and Tables 7.6.1.1A-2 being on either side of the aggregated signal. The throughput of each carrier shall be  $\geq 95\%$  of the maximum throughput of the reference measurement channels as specified in Annexes A.2.2, A.2.3 and A.3.2 (with one sided dynamic OCNG Pattern OP.1 FDD/TDD for the DL-signal as described in Annex A.5.1.1/A.5.2.1) with parameters specified in Tables 7.6.1.1A-1 and 7.6.1.1A-2. For operating bands with an unpaired DL part (as noted in Table 5.5-1), the requirements also apply for an SCC assigned in the unpaired part with parameters specified in Tables 7.6.2.1A-1 and 7.6.2.1A-2.

For intra-band non-contiguous carrier aggregation with one uplink carrier and two or more downlink sub-blocks, each larger than or equal to 5 MHz, the in-band blocking requirements are defined with the uplink configuration in accordance with Table 7.3.1A-3. For this uplink configuration, the UE shall meet the requirements for each sub-block as specified in subclause 7.6.1.1 and in this subclause for one component carrier and two component carriers per sub-block, respectively. The requirements apply for in-gap and out-of-gap interferers while all downlink carriers are active.

Table 7.6.1.1A-1: In band blocking parameters

Rx Parameter	Units	CA Bandwidth Class				
		B	C	D	E	F
Pw in Transmission Bandwidth Configuration, per CC	dBm	REFSENS + CA Bandwidth Class specific value below				
		9	12	13.8	15	16
$BW_{\text{Interferer}}$	MHz	5	5	5	5	5
$F_{\text{offset, case 1}}$	MHz	7.5	7.5	7.5	7.5	7.5
$F_{\text{offset, case 2}}$	MHz	12.5	12.5	12.5	12.5	12.5
NOTE 1: The transmitter shall be set to 4dB below $P_{\text{CMAX, Lc}}$ or $P_{\text{CMAX, L}}$ as defined in subclause 6.2.5A						
NOTE 2: The interferer consists of the Reference measurement channel specified in Annex A.3.2 with one sided dynamic OCNG Pattern OP.1 FDD/TDD as described in Annex A.5.1.1/A.5.2.1 and set-up according to Annex C.3.1						



**Table 7.6.1.1A-2: In-band blocking**

CA configuration	Parameter	Unit	Case 1	Case 2
	$P_{\text{interferer}}$	dBm	-56	-44
	$F_{\text{interferer}}$ (offset)	MHz	$=-F_{\text{offset}} - F_{\text{loffset,case 1}}$ & $=+F_{\text{offset}} + F_{\text{loffset,case 1}}$	$\leq -F_{\text{offset}} - F_{\text{loffset,case 2}}$ & $\geq +F_{\text{offset}} + F_{\text{loffset,case 2}}$
CA_1C, CA_2C, CA_3B, CA_3C, CA_5B, CA_7B, CA_7C, CA_8B, CA_12B, CA_23B, CA_27B, CA_28C, CA_38C, CA_39C, CA_40C, CA_40D, CA_40E, CA_40F, CA_41C, CA_41D, CA_41E, CA_41F, CA_42C, CA_42D, CA_42E, CA_42F, CA_43C, CA_48B, CA_48C, CA_48D, CA_48E, CA_48F, CA_66B, CA_66C, CA_66D, CA_70C	$F_{\text{interferer}}$ (Range)	MHz	(NOTE 2)	$F_{\text{DL,low}} - 15$ to $F_{\text{DL,high}} + 15$
<p>NOTE 1: For certain bands, the unwanted modulated interfering signal may not fall inside the UE receive band, but within the first 15 MHz below or above the UE receive band</p> <p>NOTE 2: For each carrier frequency the requirement is valid for two frequencies:                      a. the carrier frequency <math>-F_{\text{offset}} - F_{\text{loffset, case 1}}</math> and                      b. the carrier frequency <math>+F_{\text{offset}} + F_{\text{loffset, case 1}}</math></p> <p>NOTE 3: <math>F_{\text{offset}}</math> is the frequency offset from the center frequency of the CC being tested to the edge of aggregated channel bandwidth.</p> <p>NOTE 4: The <math>F_{\text{interferer}}</math> (offset) is the frequency separation of the center frequency of the carrier closest to the interferer and the center frequency of the interferer and shall be further adjusted to <math>\lfloor \frac{F_{\text{interferer}}}{0.015 + 0.5} \rfloor 0.015 + 0.0075</math> MHz to be offset from the sub-carrier raster.</p>				

For combinations of intra-band and inter-band carrier aggregation and one uplink carrier assigned to one E-UTRA band, the requirement is defined with the uplink active in the band other than that supporting the downlink(s) under test. The uplink configuration shall be in accordance with Table 7.3.1A-3 when the uplink is active in the band supporting two or more non-contiguous component carriers, Table 7.3.1A-1 when the uplink is active in a band supporting two contiguous component carriers and in accordance with Table 7.3.1-2 when the uplink is active in a band supporting one carrier per band. The downlink PCC shall be configured closer to the uplink operating band than the downlink SCC(s) when the uplink is active in band(s) supporting contiguous aggregation. For these uplink configurations, the UE shall meet the in-band blocking requirements for intra-band non-contiguous carrier aggregation with  $\Delta R_{\text{BNC}} = 0$  dB for all sub-block gaps (Table 7.3.1A-3) for the two or more non-contiguous downlink sub-blocks, the requirements for intra-band contiguous carrier aggregation for the contiguously aggregated downlink carriers and for any remaining component carrier(s) the requirements specified in subclause 7.6.1. For contiguously aggregated component carriers configured in Band 46, the said requirements for intra-band contiguous carrier aggregation of downlink carriers are replaced by requirements in Table 7.6.1.1A-3 and 7.6.1.1A-4. For non-contiguously aggregated component carriers configured in Band 46, the said requirements are applied to each sub-block for in-gap and out-of-gap interferers. For the sub-block with a single component carrier, the requirement is replaced by Table 7.6.1.1A-0a and 7.6.1.1A-0b. For the sub-block with two or more contiguous component carriers, the requirement is replaced by Table 7.6.1.1A-3 and 7.6.1.1A-4. All downlink carriers shall be active throughout the tests and the requirements for the downlinks shall be met with the single uplink carrier active in each band capable of uplink operation.

**Table 7.6.1.1A-3: In band blocking parameters**

E-UTRA Band	Rx Parameter	Units	CA Bandwidth Class				
			B	C	D	E	F
46	Pw in Transmission Bandwidth Configuration, per CC	dBm	REFSENS + CA Bandwidth Class specific value below				
	$BW_{\text{interferer}}$	MHz		12	13.8	15	
	$F_{\text{loffset, case 1}}$	MHz		20	20	20	
	$F_{\text{loffset, case 2}}$	MHz		30	30	30	
				50	50	50	
<p>NOTE 1: In a band capable of uplink operation, the transmitter shall be set to 4dB below <math>P_{\text{CMAX,L,C}}</math> or <math>P_{\text{CMAX,L}}</math> as defined in subclause 6.2.5A</p> <p>NOTE 2: The interferer consists of the Reference measurement channel specified in Annex A.3.2 with one sided dynamic OCNG Pattern OP.1 FDD/TDD/FS3 as described in Annex A.5.1.1/A.5.2.1/A.5.4.1 and set-up according to Annex C.3.1</p>							

Table 7.6.1.1A-4: In-band blocking

E-UTRA Band	Parameter	Unit	Case 1	Case 2
		$P_{\text{interferer}}$	dBm	-50
	$F_{\text{interferer}}$ (offset)	MHz	$\begin{matrix} =-F_{\text{offset}} - F_{\text{loffset, case 1}} \\ \& \\ =+F_{\text{offset}} + F_{\text{loffset, case 1}} \end{matrix}$	$\begin{matrix} \leq -F_{\text{offset}} - F_{\text{loffset, case 2}} \\ \& \\ \geq +F_{\text{offset}} + F_{\text{loffset, case 2}} \end{matrix}$
46	$F_{\text{interferer}}$ (Range)	MHz	(Note 2)	$\begin{matrix} F_{\text{DL, low}} - 60 \\ \text{to} \\ F_{\text{DL, high}} + 60 \end{matrix}$

NOTE 1: For certain bands, the unwanted modulated interfering signal may not fall inside the UE receive band, but within the first 15 MHz below or above the UE receive band

NOTE 2: For each carrier frequency the requirement is valid for two frequencies:  
a. the carrier frequency  $-F_{\text{offset}} - F_{\text{loffset, case 1}}$  and  
b. the carrier frequency  $+F_{\text{offset}} + F_{\text{loffset, case 1}}$

NOTE 3:  $F_{\text{offset}}$  is the frequency offset from the center frequency of the CC being tested to the edge of aggregated channel bandwidth.

NOTE 4: The  $F_{\text{interferer}}$  (offset) is the frequency separation of the center frequency of the carrier closest to the interferer and the center frequency of the interferer and shall be further adjusted to  $\lfloor \frac{F_{\text{interferer}}}{0.015 + 0.5} \rfloor \cdot 0.015 + 0.0075$  MHz to be offset from the sub-carrier raster.

## 7.6.1.1D Minimum requirements for ProSe

The throughput shall be  $\geq 95\%$  of the maximum throughput of the reference measurement channels as specified in Annex A.6.2.

Table 7.6.1.1D-1: In band blocking parameters for ProSe Direct Discovery

Rx parameter	Units	Channel bandwidth					
		1.4 MHz	3 MHz	5 MHz	10 MHz	15 MHz	20 MHz
Power in Transmission Bandwidth Configuration	dBm	P <sub>PREFSENS, ProSe</sub> + channel bandwidth specific value below + P <sub>offset</sub>					
				6	6	7	9
BW <sub>interferer</sub>	MHz			5	5	5	5
F <sub>loffset, case 1</sub>	MHz			7.5+0.0125	7.5+0.0025	7.5+0.0075	7.5+0.0125
F <sub>loffset, case 2</sub>	MHz			12.5+0.0075	12.5+0.012	12.5+0.002	12.5+0.007
P <sub>offset</sub>	dB			10.9	13.9	15.7	16.9

NOTE 1: The interferer is QPSK modulated PUSCH containing data and reference symbols. Normal cyclic prefix is used. The data content shall be uncorrelated to the wanted signal and modulated according to clause 5 of TS36.211

Table 7.6.1.1D-2: In band blocking parameters for ProSe Direct Communication

Rx parameter	Units	Channel bandwidth					
		1.4 MHz	3 MHz	5 MHz	10 MHz	15 MHz	20 MHz
Power in Transmission Bandwidth Configuration	dBm	P <sub>PREFSENS, ProSe</sub> + channel bandwidth specific value below					
				6	6	7	9
BW <sub>interferer</sub>	MHz			5	5	5	5
F <sub>loffset, case 1</sub>	MHz			7.5+0.0125	7.5+0.0025	7.5+0.0075	7.5+0.0125
F <sub>loffset, case 2</sub>	MHz			12.5+0.0075	12.5+0.012	12.5+0.002	12.5+0.007
				5	5	5	5

NOTE 1: The interferer is QPSK modulated PUSCH containing data and reference symbols. Normal cyclic prefix is used. The data content shall be uncorrelated to the wanted signal and modulated according to clause 5 of TS36.211

Table 7.6.1.1D-3: In-band blocking for ProSe

E-UTRA ProSe band	Parameter	Unit	Case 1	Case 2
	$P_{\text{interferer}}$		dBm	-56
$F_{\text{interferer}}$ (offset)		MHz	$= -BW/2 - F_{\text{offset, case 1}}$ & $= +BW/2 + F_{\text{offset, case 1}}$	$\leq -BW/2 - F_{\text{offset, case 2}}$ & $\geq +BW/2 + F_{\text{offset, case 2}}$
2,3,4,7,14,20,26,28,31	$F_{\text{interferer}}$	MHz	(NOTE 2)	$F_{\text{DL, low}} - 15$ to $F_{\text{DL, high}} + 15$
NOTE 1: For certain bands, the unwanted modulated interfering signal may not fall inside the UE receive band, but within the first 15 MHz below or above the UE receive band				
NOTE 2: For each carrier frequency the requirement is valid for two frequencies: a. the carrier frequency $-BW/2 - F_{\text{offset, case 1}}$ and b. the carrier frequency $+BW/2 + F_{\text{offset, case 1}}$				
NOTE 3: $F_{\text{interferer}}$ range values for unwanted modulated interfering signal are interferer center frequencies				

For the UE which supports inter band CA configuration in Table 7.3.1-1A,  $P_{\text{interferer}}$  power defined in Table 7.6.1.1D-3 is increased by the amount given by  $\Delta R_{\text{IB,c}}$  in Table 7.3.1-1A.

### 7.6.1.1F Minimum requirements for category NB1 and NB2

Category NB1 and NB2 UE throughput shall be  $\geq 95\%$  of the maximum throughput of the reference measurement channel as specified in Annex A.3.2 with parameters specified in Table 7.6.1.1F-1.

Table 7.6.1.1F-1: In-band blocking parameters for category NB1 and NB2

IBB1 test Parameters	
Category NB1 or NB2 signal power ( $P_{\text{wanted}}$ ) / dBm	REFSENS + 6 dB
Interferer	E-UTRA
Interferer signal power ( $P_{\text{interferer}}$ ) / dBm	- 56 dBm
Interferer bandwidth	5 MHz
Interferer offset from category NB1 or NB2 channel edge	+7.5 MHz + 0.005 MHz and -7.5 MHz - 0.005 MHz
IBB2 test Parameters	
Category NB1 or NB2 signal power ( $P_{\text{wanted}}$ ) / dBm	REFSENS + 6 dB
Interferer	E-UTRA
Interferer signal power ( $P_{\text{interferer}}$ ) / dBm	- 44 dBm
Interferer bandwidth	5 MHz
Interferer offset range from category NB1 or NB2 channel edge	From +12.5 MHz to $F_{\text{DL, high}} + 15$ MHz and From -12.5 MHz to $F_{\text{DL, low}} - 15$ MHz

### 7.6.1.1G Minimum requirements for V2X

The V2X UE throughput shall be  $\geq 95\%$  of the maximum throughput of the reference measurement channels as specified in Annex A.8.2 with parameters defined in Table 7.6.1.1G-1 and Table 7.6.1.1G-2.

Table 7.6.1.1G-1: In band blocking parameters

Rx parameter	Units	Channel bandwidth					
		1.4 MHz	3 MHz	5 MHz	10 MHz	15 MHz	20 MHz
Power in Transmission Bandwidth Configuration	dBm	P <sub>REFSENS_V2X</sub> + channel bandwidth specific value below					
					6		9
BW <sub>Interferer</sub>	MHz				10		10
F <sub>offset, case 1</sub>	MHz				15+0.0025		15+0.005
F <sub>offset, case 2</sub>	MHz				25+0.0075		25+0.0025

NOTE 1: The interferer is QPSK modulated PUSCH containing data and reference symbols. Normal cyclic prefix is used. The data content shall be uncorrelated to the wanted signal and modulated according to clause 5 of TS36.211

Table 7.6.1.1G-2: In-band blocking

E-UTRA V2X band	Parameter	Unit	Case 1	Case 2
		P <sub>Interferer</sub>	dBm	-44
	F <sub>Interferer (offset)</sub>	MHz	$\pm BW/2 - F_{\text{offset, case 1}}$ & $\pm BW/2 + F_{\text{offset, case 1}}$	$\leq BW/2 - F_{\text{offset, case 2}}$ & $\geq +BW/2 + F_{\text{offset, case 2}}$
47	F <sub>Interferer</sub>	MHz	(NOTE 2)	F <sub>DL, low</sub> - 30 to F <sub>DL, high</sub> + 30

NOTE 1: For certain bands, the unwanted modulated interfering signal may not fall inside the UE receive band, but within the first 15 MHz below or above the UE receive band

NOTE 2: For each carrier frequency the requirement is valid for two frequencies:  
a. the carrier frequency  $-BW/2 - F_{\text{offset, case 1}}$  and  
b. the carrier frequency  $+BW/2 + F_{\text{offset, case 1}}$

NOTE 3: F<sub>Interferer</sub> range values for unwanted modulated interfering signal are interferer center frequencies

When UE is configured for simultaneous E-UTRA V2X sidelink and E-UTRA downlink reception for inter-band E-UTRA V2X / E-UTRA bands specified in Table 5.5G-2, the requirements in subclause 7.6.1.1G apply for the E-UTRA V2X sidelink reception and the requirements in subclause 7.6.1.1 apply for the E-UTRA downlink reception while all downlink carriers are active.

For intra-band contiguous multi-carrier operation, the V2X UE throughput shall be  $\geq 95\%$  of the maximum throughput of the reference measurement channels as specified in Annex A.8.2 with parameters defined in Table 7.6.1.1G-3 and Table 7.6.1.1G-4.

Table 7.6.1.1G-3: In band blocking parameters for intra-band contiguous multi-carrier for V2X UE

Rx Parameter	Units	V2X Bandwidth Class				
		B	C/ C <sub>1</sub>	D	E	F
Pw in Transmission Bandwidth Configuration, per CC	dBm	REFSENS + V2X Bandwidth Class specific value below				
		9	12			
BW <sub>Interferer</sub>	MHz	10	10			
F <sub>offset, case 1</sub>	MHz	15	15			
F <sub>offset, case 2</sub>	MHz	25	25			

Table 7.6.1.1G-4: In-band blocking for intra-band contiguous multi-carrier for V2X UE

V2X multi-carrier configuration	Parameter	Unit	Case 1	Case 2
		$P_{\text{Interferer}}$	dBm	-44
	$F_{\text{Interferer}}$ (offset)	MHz	$= -F_{\text{offset}} - F_{\text{offset,case 1}}$ & $= +F_{\text{offset}} + F_{\text{offset,case 1}}$	$\leq -F_{\text{offset}} - F_{\text{offset,case 2}}$ & $\geq +F_{\text{offset}} + F_{\text{offset,case 2}}$
V2X_47B, V2X_47C, V2X_47C <sub>1</sub>	$F_{\text{Interferer}}$ (Range)	MHz	(NOTE 2)	$F_{\text{DL,low}} - 30$ to $F_{\text{DL,high}} + 30$

NOTE 1: For certain bands, the unwanted modulated interfering signal may not fall inside the UE receive band, but within the first 30 MHz below or above the UE receive band

NOTE 2: For each carrier frequency the requirement is valid for two frequencies:  
a. the carrier frequency  $-F_{\text{offset}} - F_{\text{offset, case 1}}$  and  
b. the carrier frequency  $+F_{\text{offset}} + F_{\text{offset, case 1}}$

NOTE 3:  $F_{\text{offset}}$  is the frequency offset from the center frequency of the CC being tested to the edge of aggregated channel bandwidth.

NOTE 4: The  $F_{\text{Interferer}}$  (offset) is the frequency separation of the center frequency of the carrier closest to the interferer and the center frequency of the interferer and shall be further adjusted to  $\lfloor F_{\text{Interferer}} / (0.015 + 0.5) \rfloor (0.015 + 0.0075)$  MHz to be offset from the sub-carrier raster.

NOTE 5: The requirement is applied for multi-carrier intra-band con-current receptions when 2 carrier transmissions are activated at the same time.

## 7.6.2 Out-of-band blocking

Out-of-band band blocking is defined for an unwanted CW interfering signal falling more than 15 MHz below or above the UE receive band. For the first 15 MHz below or above the UE receive band the appropriate in-band blocking or adjacent channel selectivity in subclause 7.5.1 and subclause 7.6.1 shall be applied.

For CA configurations including Band 46 or Band 49, out-of-band band blocking is defined for an unwanted CW interfering signal falling more than 60 MHz below or above the UE receive band (see Table 7.6.2.1A-0a). For the first 60 MHz below or above the UE receive band the appropriate in-band blocking or adjacent channel selectivity in subclause 7.5.1A and subclause 7.6.1A shall be applied.

### 7.6.2.1 Minimum requirements

The throughput shall be  $\geq 95\%$  of the maximum throughput of the reference measurement channels as specified in Annexes A.2.2, A.2.3 and A.3.2 (with one sided dynamic OCNG Pattern OP.1 FDD/TDD for the DL-signal as described in Annex A.5.1.1/A.5.2.1) with parameters specified in Tables 7.6.2.1-1 and 7.6.2.1-2. For operating bands with an unpaired DL part (as noted in Table 5.5-1), the requirements only apply for carriers assigned in the paired part.

For Table 7.6.2.1-2 in frequency range 1, 2 and 3, up to  $\max(24, 6 \cdot N_{RB} / 6)$  exceptions are allowed for spurious response frequencies in each assigned frequency channel when measured using a 1MHz step size, where  $N_{RB}$  is the number of resource blocks in the downlink transmission bandwidth configuration (see Figure 5.6-1). For these exceptions the requirements of subclause 7.7 Spurious response are applicable.

For Table 7.6.2.1-2 in frequency range 4, up to  $\max(8, (N_{RB} + 2 \cdot L_{CRBs}) / 8)$  exceptions are allowed for spurious response frequencies in each assigned frequency channel when measured using a 1MHz step size, where  $N_{RB}$  is the number of resource blocks in the downlink transmission bandwidth configurations (see Figure 5.6-1) and  $L_{CRBs}$  is the number of resource blocks allocated in the uplink. For these exceptions the requirements of clause 7.7 spurious response are applicable.

**Table 7.6.2.1-1: Out-of-band blocking parameters**

Rx Parameter	Units	Channel bandwidth					
		1.4 MHz	3 MHz	5 MHz	10 MHz	15 MHz	20 MHz
Power in Transmission Bandwidth Configuration	dBm	REFSENS + channel bandwidth specific value below					
		6	6	6	6	7	9
<p>NOTE 1: The transmitter shall be set to 4dB below <math>P_{CMAX,L}</math> at the minimum uplink configuration specified in Table 7.3.1-2 with <math>P_{CMAX,L}</math> as defined in subclause 6.2.5.</p> <p>NOTE 2: Reference measurement channel is specified in Annex A.3.2 with one sided dynamic OCNG Pattern OP.1 FDD/TDD as described in Annex A.5.1.1/A.5.2.</p> <p>NOTE 3: The REFSENS power level is specified in Table 7.3.1-1 and Table 7.3.1-1a for two and four antenna ports, respectively.</p> <p>NOTE 4: For DL category M1 and M2 UE, the reference sensitivity for category M1 in table 7.3.1E-3 and category M2 in Table 7.3.1E-8 should be used as REFSENS for the power in Transmission Bandwidth Configuration.</p> <p>NOTE5: For DL category M1 and M2 UE, the parameters for the applicable channel bandwidth apply.</p>							

**Table 7.6.2.1-2: Out of band blocking**

E-UTRA band	Parameter	Units	Frequency			
			Range 1	Range 2	Range 3	Range 4
	$P_{Interferer}$	dBm	-44	-30	-15	-15
1, 2, 3, 4, 5, 6, 7, 8, 9, 10, 11, 12, 13, 14, 17, 18, 19, 20, 21, 22, 23, 24, 25, 26, 27, 28, 30, 31, 33, 34, 35, 36, 37, 38, 39, 40, 41, 42 (NOTE 2), 43 (NOTE 2), 44, 45, 48 (NOTE 2), 50, 51, 52 (NOTE 6), 53 <sup>9</sup> , 65, 66, 68, 70, 71, 72, 73, 74, 85, 87, 88	$F_{Interferer}$ (CW)	MHz	$F_{DL,low} -15$ to $F_{DL,low} -60$	$F_{DL,low} -60$ to $F_{DL,low} -85$	$F_{DL,low} -85$ to 1 MHz	-
			$F_{DL,high} +15$ to $F_{DL,high} + 60$	$F_{DL,high} +60$ to $F_{DL,high} +85$	$F_{DL,high} +85$ to +12750 MHz	-
2, 5, 12, 17, 85	$F_{Interferer}$	MHz	-	-	-	$F_{UL,low} - F_{UL,high}$ (NOTE 5)
<p>NOTE 1: For the UE which supports both Band 11 and Band 21 the out of blocking is FFS.</p> <p>NOTE 2: The power level of the interferer (<math>P_{Interferer}</math>) for Range 3 shall be modified to -20 dBm for <math>F_{Interferer} &gt; 2800</math> MHz and <math>F_{Interferer} &lt; 4400</math> MHz. The power level of the interferer (<math>P_{Interferer}</math>) for Range 3 shall be modified to -20 dBm for <math>F_{Interferer} &gt; 2800</math> MHz and <math>F_{Interferer} &lt; 4800</math> MHz when UE supports both E-UTRA band B42 and NR bands n77, n78.</p> <p>NOTE 3: For the UE that supports both Band 4 and Band 66, the out-of-blocking frequency range for Band 4 is defined relative to <math>F_{DL,low}</math> and <math>F_{DL,high}</math> of Band 66.</p> <p>NOTE 4: For a UE supporting CA_20A-28A, CA_1A-3A-7A-20A-28A, CA_1A-3A-20A-28A, CA_1A-3A-3A-20A-28A, CA_1A-7A-20A-28A, CA_1A-20A-28A, CA_3A-7A-20A-28A, CA_3A-20A-28A or CA_7A-20A-28A the requirements for Band 20 and Band 28 apply with <math>F_{DL,low}</math> given by the lower limit of the restricted operating frequency range in Band 28 and <math>F_{DL,high}</math> by Band 20 (Table 5.5A-2).</p> <p>NOTE 5: Range 4 requirement does not apply to category M1 and M2.</p> <p>NOTE 6: The power level of the interferer (<math>P_{Interferer}</math>) for Range 3 shall be modified to -20 dBm for <math>F_{Interferer} &gt; 2700</math> MHz and <math>F_{Interferer} &lt; 4000</math> MHz.</p> <p>NOTE 7: For band 51 the <math>F_{DL,high}</math> of band 50 is applied as <math>F_{DL,high}</math> for band 51.</p> <p>NOTE 8: For UEs supporting both bands 38 and 41, the <math>F_{DL,high}</math> and <math>F_{DL,low}</math> of band 41 is applied as <math>F_{DL,high}</math> and <math>F_{DL,low}</math> for band 38.</p> <p>NOTE 9: The power level of the interferer (<math>P_{Interferer}</math>) for Range 3 shall be modified to [-20 dBm] for <math>F_{Interferer} &gt; [2580</math> MHz] and <math>F_{Interferer} &lt; [2775</math> MHz].</p>						

### 7.6.2.1A Minimum requirements for CA

For inter-band carrier aggregation with one component carrier per operating band and the uplink assigned to one E-UTRA band, the out-of-band blocking requirements are defined with the uplink active on the band(s) other than the band whose downlink is being tested. The throughput in the downlink measured shall be  $\geq 95\%$  of the maximum throughput of the reference measurement channels as specified in Annexes A.2.2, A.2.3 and A.3.2 (with one sided dynamic OCN Pattern OP.1 FDD/TDD for the DL-signal as described in Annex A.5.1.1/A.5.2.1) with parameters specified in Tables 7.6.2.1-1 and 7.6.2.1A-0. For E-UTRA CA configurations including an operating band without uplink operation (as noted in Table 5.5-1), the requirements for all downlinks shall be met with the uplink active in the band(s) capable of UL operation. For the E-UTRA CA configurations with band 46 or Band 49, the parameters specified in Table 7.6.2.1A-0 are replaced by those specified in Table 7.6.2.1A-0a. The UE shall meet these requirements for each component carrier while all downlink carriers are active.

For inter-band carrier aggregation with one component carrier per operating band and the uplink active in two E-UTRA bands, the out-of-band blocking requirements specified above shall be met with the transmitter power for the uplink set to 7 dB below  $P_{\text{CMAX},L,c}$  for each serving cell  $c$ .

For E-UTRA CA configurations including an operating band without uplink band or an operating band with an unpaired DL part (as noted in Table 5.5-1), the requirements for all downlinks shall be met with the single uplink carrier active in each band capable of UL operation. For E-UTRA CA configurations listed in Table 7.3.1A-0a under conditions for which reference sensitivity for the operating band being tested is N/A, the out-of-band blocking requirements of subclause 7.6.2.1A do not apply.

**Table 7.6.2.1A-0: out-of-band blocking for inter-band carrier aggregation**

Parameter	Unit	Range 1	Range 2	Range 3
$P_w$	dBm	Table 7.6.2.1-1 for all component carriers		
$P_{\text{Interferer}}$	dBm	$-44 + \Delta R_{\text{IB},c}$	$-30 + \Delta R_{\text{IB},c}$	$-15 + \Delta R_{\text{IB},c}$
$F_{\text{Interferer}}$ (CW)	MHz	$-60 < f - F_{\text{DL\_Low}(j)} < -15$ or $15 < f - F_{\text{DL\_High}(j)} < 60$	$-85 < f - F_{\text{DL\_Low}(j)} \leq -60$ or $60 \leq f - F_{\text{DL\_High}(j)} < 85$	$1 \leq f \leq F_{\text{DL\_Low}(1)} - 85$ or $F_{\text{DL\_High}(j)} + 85 \leq f$ $\leq F_{\text{DL\_Low}(j+1)} - 85$ with $j < X$ or $F_{\text{DL\_High}(X)} + 85 \leq f$ $\leq 12750$
NOTE 1: $F_{\text{DL\_Low}(j)}$ and $F_{\text{DL\_High}(j)}$ denote the respective lower and upper frequency limits of the operating band containing carrier $j$ , $j = 1, \dots, X$ , with carriers numbered in increasing order of carrier frequency and $X$ the number of component carriers in the band combination.				
NOTE 2: For $F_{\text{DL\_Low}(j+1)} - F_{\text{DL\_High}(j)} < 145$ MHz and $F_{\text{Interferer}}$ in $F_{\text{DL\_High}(j)} < f < F_{\text{DL\_Low}(j+1)}$ with $j < X$ , $F_{\text{Interferer}}$ can be in both Range 1 and Range 2. Then the lower of the $P_{\text{Interferer}}$ applies.				
NOTE 3: For $F_{\text{DL\_Low}(j)} - 15$ MHz $\leq f \leq F_{\text{DL\_High}(j)} + 15$ MHz the appropriate adjacent channel selectivity and in-band blocking requirements in the respective subclauses 7.5.1A and 7.6.1.1A shall be applied for carrier $j$ .				
NOTE 4: $\Delta R_{\text{IB},c}$ according to Table 7.3.1-1A applies when serving cell $c$ is measured.				
NOTE 5: For inter-band CA combinations containing Bands 42 or 43, the interferer with respect to Band 42 or Band 43 shall have power level ( $P_{\text{Interferer}}$ ) for Range 3 modified to $-20 + \Delta R_{\text{IB},c}$ dBm for $F_{\text{Interferer}} > 2800$ MHz and $F_{\text{Interferer}} < 4400$ MHz.				
NOTE 6: For inter-band CA combinations containing Bands 7 and 38 simultaneously, for $F_{\text{Interferer}}$ Bands 7 and 38 are considered as one single band as follows: $F_{\text{DL\_Low}} = 2570$ MHz and $F_{\text{DL\_High}} = 2690$ MHz. For Range 2, the following applies for $F_{\text{DL\_Low}}$ : $-95 < f - F_{\text{DL\_Low}} \leq -60$ or $60 \leq f - F_{\text{DL\_High}} < 85$ . For Range 3 the following applies $1 \leq f \leq F_{\text{DL\_Low}} - 95$ or $F_{\text{DL\_High}} + 85 \leq f \leq 12750$ .				
NOTE 7: For CA_20A-28A, CA_1A-3A-7A-20A-28A, CA_1A-3A-20A-28A, CA_1A-3A-3A-20A-28A, CA_1A-7A-20A-28A, CA_1A-20A-28A, CA_3A-7A-20A-28A, CA_3A-20A-28A and CA_7A-20A-28A the $F_{\text{DL\_low}(1)}$ is given by the lower limit of the restricted operating frequency range in Band 28 and $F_{\text{DL\_high}(2)}$ by Band 20 (Table 5.5A-2).				
NOTE 8: For inter-band CA combinations including DL in band 76, the $F_{\text{DL\_high}}$ of band 75 is applied as $F_{\text{DL\_high}}$ for band 76.				
NOTE 9: For CA band combinations including DL in band 32, $F_{\text{DL\_high}}$ of band 75 is applied as $F_{\text{DL\_high}}$ for band 32, and $F_{\text{DL\_low}}$ of band 76 is applied as $F_{\text{DL\_low}}$ for band 32.				

**Table 7.6.2.1A-0a: out-of-band blocking for inter-band carrier aggregation with band 46 or Band 49 and with one active uplink**

Parameter	Unit	Range 1	Range 2	Range 3
$P_{\text{wanted}}$	dBm	Table 7.6.2.1-1 for component carriers in bands with $j \leq K$ and Table 7.6.1.1A-0a for component carriers in bands with $j > K$		
$P_{\text{interferer}}$	dBm	$-44 + \Delta R_{\text{IB},c}$	$-30 + \Delta R_{\text{IB},c}$	$-15 + \Delta R_{\text{IB},c}$ (NOTE 5)
$F_{\text{interferer}}$ (CW)	MHz	$-60 < f - F_{\text{DL\_Low}(j)} < -15$ with $j \leq K$ or $15 < f - F_{\text{DL\_High}(j)} < 60$ with $j \leq K$	$-85 < f - F_{\text{DL\_Low}(j)} \leq -60$ or $60 \leq f - F_{\text{DL\_High}(j)} < 85$	$1 \leq f \leq F_{\text{DL\_Low}(j)} - 85$ or $F_{\text{DL\_High}(j)} + 85 \leq f \leq 12750$
NOTE 1: $F_{\text{DL\_Low}(j)}$ and $F_{\text{DL\_High}(j)}$ , $j = 1, \dots, K, \dots, N$ , denote the respective lower and upper frequency limits of the (non-overlapping) operating bands of the CA configuration numbered in increasing order of frequency, with N the number of bands in the band combination and K the number of bands with $F_{\text{DL\_High}} \leq 3800$ MHz for Band 46 and $F_{\text{DL\_High}} \leq 2700$ MHz for Band 49.				
NOTE 2: For $F_{\text{DL\_Low}(j)} - 15 \text{ MHz} \leq f \leq F_{\text{DL\_High}(j)} + 15 \text{ MHz}$ the appropriate adjacent channel selectivity and in-band blocking requirements in the respective subclauses 7.5.1A and 7.6.1.1A shall be applied for carrier $j \leq K$ .				
NOTE 3: For $F_{\text{DL\_Low}(j)} - 60 \text{ MHz} \leq f \leq F_{\text{DL\_High}(j)} + 60 \text{ MHz}$ the appropriate adjacent channel selectivity and in-band blocking requirements in the respective subclauses 7.5.1A and 7.6.1.1A shall be applied for carrier $K < j \leq N$ .				
NOTE 4: $\Delta R_{\text{IB},c}$ according to Table 7.3.1-1A applies when serving cell $c$ is measured.				
NOTE 5: The power level ( $P_{\text{interferer}}$ ) for Range 3 is modified to -20 dBm for $F_{\text{interferer}} > 4400$ MHz except for band combinations with Band 42 or Band 43 for which $P_{\text{interferer}}$ for Range 3 is modified to -20 dBm for $F_{\text{interferer}} > 2800$ MHz.				

For Table 7.6.2.1A-0 and Table 7.6.2.1A-0b in frequency ranges 1, 2 and 3, up to  $\max(24,6 \cdot \lceil N_{\text{RB}} / 6 \rceil)$  exceptions per downlink are allowed for spurious response frequencies for one active uplink when measured using a step size of 1 MHz.

For Table 7.6.2.1A-0 in frequency ranges 1, 2 and 3, up to  $2 \cdot \max(24,6 \cdot \lceil N_{\text{RB}} / 6 \rceil)$  exceptions per downlink are allowed for spurious response frequencies for two active uplinks when measured using a step size of 1 MHz. For these exceptions the requirements in clause 7.7.1A apply.

For intra-band contiguous carrier aggregations the downlink SCC(s) shall be configured at nominal channel spacing to the PCC. For FDD, the PCC shall be configured closest to the uplink band. All downlink carriers shall be active throughout the test. The uplink output power shall be set as specified in Table 7.6.2.1A-1 with the uplink configuration set according to Table 7.3.1A-1 for the applicable carrier aggregation configuration. For UE(s) supporting one uplink carrier, the uplink configuration of the PCC shall be in accordance with Table 7.3.1-2.

The UE shall fulfil the minimum requirement in presence of an interfering signal specified in Tables 7.6.2.1A-1 and Tables 7.6.2.1A-2 being on either side of the aggregated signal. The throughput of each carrier shall be  $\geq 95\%$  of the maximum throughput of the reference measurement channels as specified in Annexes A.2.2, A.2.3 and A.3.2 (with one sided dynamic OCNG Pattern OP.1 FDD/TDD for the DL-signal as described in Annex A.5.1.1/A.5.2.1) with parameters specified in Tables 7.6.2.1A-1 and 7.6.2.1A-2. For operating bands with an unpaired DL part (as noted in Table 5.5-1), the requirements also apply for an SCC assigned in the unpaired part with parameters specified in Tables 7.6.2.1A-1 and 7.6.2.1A-2.

For Table 7.6.2.1A-2 in frequency range 1, 2 and 3, up to  $\max(24,6 \cdot \lceil N_{\text{RB}} / 6 \rceil)$  exceptions are allowed for spurious response frequencies in each assigned frequency channel when measured using a 1MHz step size. For these exceptions the requirements of subclause 7.7 Spurious response are applicable.

**Table 7.6.2.1A-1: Out-of-band blocking parameters**

Rx Parameter	Units	CA Bandwidth Class				
		B	C	D	E	F
$P_w$ in Transmission Bandwidth Configuration, per CC	dBm	REFSENS + CA Bandwidth Class specific value below				
		9	9	9	9	9



NOTE 1: The transmitter shall be set to 4dB below  $P_{\text{CMAX\_L,c}}$  or  $P_{\text{CMAX\_L}}$  as defined in subclause 6.2.5A.  
 NOTE 2: Reference measurement channel is specified in Annex A.3.2 with one sided dynamic OCNG Pattern OP.1 FDD/TDD as described in Annex A.5.1.1/A.5.2.

Table 7.6.2.1A-2: Out of band blocking

CA configuration	Parameter	Units	Frequency		
			Range 1	Range 2	Range 3
	$P_{\text{interferer}}$	dBm	-44	-30	-15
CA_1C, CA_2C, CA_3B, CA_3C, CA_5B, CA_7B, CA_7C, CA_8B, CA_12B, CA_23B, CA_27B, CA_28C, CA_38C, CA_39C, CA_40C, CA_40D, CA_40E, CA_40F, CA_41C, CA_41D, CA_41E, CA_41F, CA_42C <sup>1</sup> , CA_42D <sup>1</sup> , CA_42E <sup>1</sup> , CA_42F <sup>1</sup> , CA_43C <sup>1</sup> , CA_48B <sup>1</sup> , CA_48C <sup>1</sup> , CA_48D <sup>1</sup> , CA_48E <sup>1</sup> , CA_48F <sup>1</sup> , CA_66B, CA_66C, CA_66D, CA_70C	$F_{\text{interferer}}$ (CW)	MHz	$F_{\text{DL\_low}} - 15$ to $F_{\text{DL\_low}} - 60$	$F_{\text{DL\_low}} - 60$ to $F_{\text{DL\_low}} - 85$	$F_{\text{DL\_low}} - 85$ to 1 MHz
			$F_{\text{DL\_high}} + 15$ to $F_{\text{DL\_high}} + 60$	$F_{\text{DL\_high}} + 60$ to $F_{\text{DL\_high}} + 85$	$F_{\text{DL\_high}} + 85$ to +12750 MHz
NOTE 1: The power level of the interferer ( $P_{\text{interferer}}$ ) for this CA configuration for Range 3 shall be modified to -20 dBm for $F_{\text{interferer}} > 2800$ MHz and $F_{\text{interferer}} < 4400$ MHz. The power level of the interferer ( $P_{\text{interferer}}$ ) for Range 3 shall be modified to -20 dBm for $F_{\text{interferer}} > 2800$ MHz and $F_{\text{interferer}} < 4800$ MHz when UE supports both E-UTRA band B42 and NR bands n77, n78.					

For intra-band non-contiguous carrier aggregation with one uplink carrier and two or more downlink sub-blocks, the out-of-band blocking requirements are defined with the uplink configuration in accordance with table 7.3.1A-3. For this uplink configuration, the UE shall meet the requirements for each sub-block as specified in subclauses 7.6.2.1 and 7.6.2.1A for one component carrier and two or more component carriers per sub-block, respectively. The requirements apply with all downlink carriers active.

For Table 7.6.2.1-2 in frequency range 1, 2 and 3, up to  $\max(24,6 \cdot \lceil N_{\text{RB}} / 6 \rceil)$  exceptions per assigned E-UTRA channel per sub-block of the E-UTRA CA configuration are allowed for spurious response frequencies for one active uplink when measured using a 1MHz step size. For these exceptions the requirements of subclause 7.7 spurious response are applicable.

For Table 7.6.2.1-2 in frequency range 4, up to  $\max(8, \lceil (N_{\text{RB}} + 2 \cdot L_{\text{CRBs}}) / 8 \rceil)$  exceptions per assigned E-UTRA channel per sub-block of the E-UTRA CA configuration are allowed for spurious response frequencies for one active uplink when measured using a 1MHz step size. For these exceptions the requirements of clause 7.7 spurious response are applicable.

For intra-band non-contiguous carrier aggregation with two uplink carriers and two or more downlink carriers, the out-of-band blocking requirements are defined with the uplink configuration of the PCC and SCC being in accordance with Table 7.3.1A-4 and powers of both carriers set to  $P_{\text{CMAX\_L,c}} - 7$  dBm. The UE shall meet the requirements specified in subclause 7.6.2.1 for each component carrier while both downlink carriers are active.

For Table 7.6.2.1-2 in frequency range 1, 2 and 3, up to  $2 \cdot \max(24,6 \cdot \lceil N_{\text{RB}} / 6 \rceil)$  exceptions per assigned E-UTRA channel per sub-block of the E-UTRA CA configuration are allowed for spurious response frequencies for two active uplinks in the same operating band when measured using a 1MHz step size. For these exceptions the requirements of subclause 7.7 spurious response are applicable.

For Table 7.6.2.1-2 in frequency range 4, up to  $2 \cdot \max(8, \lceil (N_{\text{RB}} + 2 \cdot L_{\text{CRBs}}) / 8 \rceil)$  exceptions per assigned E-UTRA channel per sub-block of the E-UTRA CA configuration are allowed for spurious response frequencies for two active uplinks in the same operating band when measured using a 1MHz step size. For these exceptions the requirements of clause 7.7 spurious response are applicable.

For combinations of intra-band and inter-band carrier aggregation and the uplink assigned to one E-UTRA band, the requirement is defined with the uplink active in a band other than that supporting the downlink(s) under test. The uplink configuration shall be in accordance with Table 7.3.1A-3 when the uplink is active in the band supporting two or more non-contiguous component carriers, Table 7.3.1A-1 when the uplink is active in a band supporting two contiguous component carriers and in accordance with Table 7.3.1-2 when the uplink is active in a band supporting one carrier per band. The downlink PCC shall be configured closer to the uplink operating band than the downlink SCC(s) when the uplink is active in band(s) supporting contiguous aggregation. For the two or more non-contiguous component carriers

within the same band,  $P_{\text{wanted}}$  in Table 7.6.2.1A-0 is set using  $\Delta R_{\text{IBNC}} = 0$  dB for all sub-block gaps (Table 7.3.1A-3) while a band supporting contiguously aggregated carriers the out-of-band blocking parameters in Table 7.6.2.1-1 are replaced by those specified in Table 7.6.2.1A-1. For each downlink the UE shall meet the out-of-band blocking requirements applicable for inter-band carrier aggregation with one component carrier per operating band with the following exception. For each component carrier of the E-UTRA CA Configurations with band 46 or band 49, the requirements specified in Table 7.6.2.1A-0 are replaced by those in Table 7.6.2.1A-0a. All downlink carriers shall be active throughout the tests and the requirements for the downlinks shall be met with the single uplink carrier active in each band capable of UL operation.

### 7.6.2.1D Minimum requirements for ProSe

The throughput shall be  $\geq 95\%$  of the maximum throughput of the reference measurement channels as specified in Annex A.6.2 with parameters specified in Tables 7.6.2.1D-1, 7.6.2.1D-2 and 7.6.2.1D-3.

For Table 7.6.2.1D-3 in frequency range 1, 2 and 3, up to  $\max(24, 6 \cdot N_{RB} / 6)$  exceptions are allowed for spurious response frequencies in each assigned frequency channel when measured using a 1MHz step size, where  $N_{RB}$  is the number of resource blocks in the downlink transmission bandwidth configuration (see Figure 5.6-1). For these exceptions the requirements of subclause 7.7 Spurious response are applicable.

**Table 7.6.2.1D-1: Out-of-band blocking parameters for ProSe Direct Discovery**

Rx Parameter	Units	Channel bandwidth					
		1.4 MHz	3 MHz	5 MHz	10 MHz	15 MHz	20 MHz
Power in Transmission Bandwidth Configuration	dBm	$P_{\text{REFSENS\_ProSe}}$ + channel bandwidth specific value below + $P_{\text{offset}}$					
				6	6	7	9
$P_{\text{offset}}$	dB			10.9	13.9	15.7	16.9

NOTE 2: Reference measurement channel is specified in Annex A.6.2.

**Table 7.6.2.1D-2: Out-of-band blocking parameters for ProSe Direct Communication**

Rx Parameter	Units	Channel bandwidth					
		1.4 MHz	3 MHz	5 MHz	10 MHz	15 MHz	20 MHz
Power in Transmission Bandwidth Configuration	dBm	$P_{\text{REFSENS\_ProSe}}$ + channel bandwidth specific value below					
				6	6	7	9

NOTE 1: Reference measurement channel is specified in Annex A.6.2.

**Table 7.6.2.1D-3: Out of band blocking for ProSe**

E-UTRA ProSe band	Parameter	Units	Frequency		
			Range 1	Range 2	Range 3
	$P_{\text{interferer}}$	dBm	-44	-30	-15
2,3,4,7,14, 20,26,28,31,72	$F_{\text{interferer}}$ (CW)	MHz	$F_{\text{DL\_low}} -15$ to $F_{\text{DL\_low}} -60$	$F_{\text{DL\_low}} -60$ to $F_{\text{DL\_low}} -85$	$F_{\text{DL\_low}} -85$ to 1 MHz
			$F_{\text{DL\_high}} +15$ to $F_{\text{DL\_high}} +60$	$F_{\text{DL\_high}} +60$ to $F_{\text{DL\_high}} +85$	$F_{\text{DL\_high}} +85$ to +12750 MHz

NOTE 1: For the UE which supports both Band 11 and Band 21 the out of blocking is FFS.

### 7.6.2.1F Minimum requirements for category NB1 and NB2

The category NB1 and NB2 UE throughput shall be  $\geq 95\%$  of the maximum throughput of the reference measurement channels as specified in Annexes A.3.2 with parameters specified in Table 7.6.2.1F-1.

For Table 7.6.2.1F-1 in frequency range 1, 2 and 3, up to 24 exceptions are allowed for spurious response frequencies in each assigned frequency channel when measured using a 1MHz step size. For these exceptions the requirements of subclause 7.7.1F spurious response are applicable.

**Table 7.6.2.1F-1: Out-of-band blocking parameters for category NB1 and NB2 UE**

Parameter	Units	Frequency		
		Range 1	Range 2	Range 3
$P_{\text{wanted}}$	dBm	REFSENS + 6 dB		
$P_{\text{interferer (CW)}}$	dBm	-44	-30	-15
$F_{\text{interferer range}}$	MHz	$F_{\text{DL\_low}} - 15$ to $F_{\text{DL\_low}} - 60$	$F_{\text{DL\_low}} - 60$ to $F_{\text{DL\_low}} - 85$	$F_{\text{DL\_low}} - 85$ to 1 MHz
	MHz	$F_{\text{DL\_high}} + 15$ to $F_{\text{DL\_high}} + 60$	$F_{\text{DL\_high}} + 60$ to $F_{\text{DL\_high}} + 85$	$F_{\text{DL\_high}} + 85$ to 12750 MHz
NOTE 1: For operating bands which downlink band frequency range is between 617 MHz < f < 1 GHz the power level of the interferer ( $P_{\text{interferer}}$ ) for Range 3 shall be modified to: -18 dBm for the frequency range which is bounded by $F_{\text{DL\_low}} - 150$ MHz of the lowest band that UE supports in frequency range 617 MHz < f < 1 GHz and $F_{\text{DL\_high}} + 150$ MHz of the highest band that UE supports in frequency range 617 MHz < f < 1 GHz.				
NOTE 2: For operating bands which downlink band frequency range is between 1475.9 MHz < f < 2690 MHz the power level of the interferer ( $P_{\text{interferer}}$ ) for Range 3 shall be modified to: -20 dBm for the frequency range which is bounded by $F_{\text{DL\_low}} - 200$ MHz of the lowest band that UE supports in frequency range 1475.9 MHz < f < 2690 MHz and $F_{\text{DL\_high}} + 200$ MHz of the highest band that UE supports supports in frequency range 1475.9 MHz < f < 2690 MHz.				
NOTE 3: For operating bands which downlink band frequency range is between 460 MHz < f < 467.5 MHz the power level of the interferer ( $P_{\text{interferer}}$ ) for Range 3 shall be modified to: -18 dBm for the frequency range which is bounded by $F_{\text{DL\_low}} - 150$ MHz of the lowest band that UE supports in frequency range 460 MHz < f < 467.5 MHz and $F_{\text{DL\_high}} + 150$ MHz of the highest band that UE supports supports in frequency range 460 MHz < f < 467.5.				
NOTE 4: The power level of the interferer ( $P_{\text{interferer}}$ ) for Range 3 shall be modified to -20 dBm for $F_{\text{interferer}} > 2800$ MHz and $F_{\text{interferer}} < 4400$ MHz.				

### 7.6.2.1G Minimum requirements for V2X

The throughput shall be  $\geq 95\%$  of the maximum throughput of the reference measurement channels as specified in Annex A.8.2 with parameters specified in Tables 7.6.2.1G-1, 7.6.2.1G-2.

For Table 7.6.2.1G-2 in frequency range 1, 2 and 3, up to  $\max(24, 6 \cdot N_{RB} / 6)$  exceptions are allowed for spurious response frequencies in each assigned frequency channel when measured using a 1MHz step size, where  $N_{RB}$  is the number of resource blocks in the downlink transmission bandwidth configuration (see Figure 5.6-1). For these exceptions the requirements of subclause 7.7 spurious response are applicable.

**Table 7.6.2.1G-1: Out-of-band blocking parameters**

Rx Parameter	Units	Channel bandwidth					
		1.4 MHz	3 MHz	5 MHz	10 MHz	15 MHz	20 MHz
Power in Transmission Bandwidth Configuration	dBm	PREFSENS_V2X + channel bandwidth specific value below					
					6		9
NOTE 1: Reference measurement channel is specified in Annex A.8.2.							

Table 7.6.2.1G-2: Out of band blocking

E-UTRA V2X band	Parameter	Units	Frequency		
			Range 1	Range 2	Range 3
	$P_{\text{Interferer}}$	dBm	-44	-30	-15
47	$F_{\text{Interferer}} \text{ (CW)}$	MHz	$F_{\text{DL\_low}} -30$ to $F_{\text{DL\_low}} -60$	$F_{\text{DL\_low}} -60$ to $F_{\text{DL\_low}} -85$	$F_{\text{DL\_low}} -85$ to 1 MHz
			$F_{\text{DL\_high}} +30$ to $F_{\text{DL\_high}} + 60$	$F_{\text{DL\_high}} +60$ to $F_{\text{DL\_high}} +85$	$F_{\text{DL\_high}} +85$ to +12750 MHz
NOTE: The power level of the interferer ( $P_{\text{Interferer}}$ ) for Range 3 shall be modified to -20 dBm for $F_{\text{Interferer}} > 4400$ MHz.					

When UE is configured for simultaneous E-UTRA V2X sidelink and E-UTRA downlink reception for inter-band E-UTRA V2X / E-UTRA bands specified in Table 5.5G-2, the requirements in subclause 7.6.2.1G apply for the E-UTRA V2X sidelink reception and the requirements in subclause 7.6.2.1 apply for the E-UTRA downlink reception while all downlink carriers are active.

For intra-band contiguous multi-carrier operation, the V2X UE throughput shall be  $\geq 95\%$  of the maximum throughput of the reference measurement channels as specified in Annex A.8.2 with parameters specified in Tables 7.6.2.1G-3 and 7.6.2.1G-4.

For Table 7.6.2.1G-4 in frequency range 1, 2 and 3, up to  $\max(24,6 \cdot \lceil N_{RB} / 6 \rceil)$  exceptions are allowed for spurious response frequencies in each assigned frequency channel when measured using a 1MHz step size. For these exceptions the requirements of subclause 7.7 spurious response are applicable.

Table 7.6.2.1G-3: Out-of-band blocking parameters for intra-band contiguous multi-carrier for V2X UE

Rx Parameter	Units	V2X Bandwidth Class				
		B	C/ C <sub>1</sub>	D	E	F
$P_w$ in Transmission Bandwidth Configuration, per CC	dBm	REFSENS + V2X Bandwidth Class specific value below				
		9	9			

Table 7.6.2.1G-4: Out of band blocking for intra-band contiguous multi-carrier for V2X UE

V2X multi-carrier configuration	Parameter	Units	Frequency		
			Range 1	Range 2	Range 3
	$P_{\text{Interferer}}$		dBm	-44	-30
V2X_47B, V2X_47C, V2X_47C <sub>1</sub>	$F_{\text{Interferer}} \text{ (CW)}$	MHz	$F_{\text{DL\_low}} -30$ to $F_{\text{DL\_low}} -60$	$F_{\text{DL\_low}} -60$ to $F_{\text{DL\_low}} -85$	$F_{\text{DL\_low}} -85$ to 1 MHz
			$F_{\text{DL\_high}} +30$ to $F_{\text{DL\_high}} + 60$	$F_{\text{DL\_high}} +60$ to $F_{\text{DL\_high}} +85$	$F_{\text{DL\_high}} +85$ to +12750 MHz
NOTE 1: The power level of the interferer ( $P_{\text{Interferer}}$ ) for Range 3 shall be modified to -20 dBm for $F_{\text{Interferer}} > 4400$ MHz.					
NOTE 2: The requirement is applied for multi-carrier intra-band con-current receptions when 2 carrier transmissions are activated at the same time.					

## 7.6.3 Narrow band blocking

This requirement is measure of a receiver's ability to receive a E-UTRA signal at its assigned channel frequency in the presence of an unwanted narrow band CW interferer at a frequency, which is less than the nominal channel spacing.

### 7.6.3.1 Minimum requirements

The relative throughput shall be  $\geq 95\%$  of the maximum throughput of the reference measurement channels as specified in Annexes A.2.2, A.2.3 and A.3.2 (with one sided dynamic OCNG Pattern OP.1 FDD/TDD for the DL-signal as described in Annex A.5.1.1/A.5.2.1) with parameters specified in Table 7.6.3.1-1. For operating bands with an unpaired DL part (as noted in Table 5.5-1), the requirements only apply for carriers assigned in the paired part.

Table 7.6.3.1-1: Narrow-band blocking

Parameter	Unit	Channel Bandwidth					
		1.4 MHz	3 MHz	5 MHz	10 MHz	15 MHz	20 MHz
$P_w$	dBm	$P_{\text{REFSENS}} + \text{channel-bandwidth specific value below}$					
		22	18	16	13	14	16
$P_{\text{UW}}(\text{CW})$	dBm	-55	-55	-55	-55	-55	-55
$F_{\text{UW}}$ (offset for $\Delta f = 15$ kHz)	MHz	0.9075	1.7025	2.7075	5.2125	7.7025	10.2075
$F_{\text{UW}}$ (offset for $\Delta f = 7.5$ kHz)	MHz						
NOTE 1: The transmitter shall be set a 4 dB below $P_{\text{CMAX,L}}$ at the minimum uplink configuration specified in Table 7.3.1-2 with $P_{\text{CMAX,L}}$ as defined in subclause 6.2.5.							
NOTE 2: Reference measurement channel is specified in Annex A.3.2 with one sided dynamic OCNG Pattern OP.1 FDD/TDD as described in Annex A.5.1.1/A.5.2.1.							
NOTE 3: The $P_{\text{REFSENS}}$ power level is specified in Table 7.3.1-1 and Table 7.3.1-1a for two and four antenna ports, respectively.							
NOTE 4: For DL category M1 and M2 UE, the reference sensitivity for category M1 in table 7.3.1E-3 and category M2 in Table 7.3.1E-8 should be used as $P_{\text{REFSENS}}$ for $P_w$ .							
NOTE5: For DL category M1 and M2 UE, the parameters for the applicable channel bandwidth apply.							
NOTE6: For DL category M1 UE, the parameter, $P_w$ , for all the channel bandwidth will be $P_{\text{REFSENS}} + 22$ dBm.							
NOTE7: For DL category M2 UE, the parameter, $P_w$ , for all channel bandwidths greater than 3 MHz will be $P_{\text{REFSENS}} + 16$ dBm.							

For the UE which supports inter-band CA configuration in Table 7.3.1-1A,  $P_{\text{UW}}$  power defined in Table 7.6.3.1-1 is increased by the amount given by  $\Delta R_{\text{B,c}}$  in Table 7.3.1-1A.

### 7.6.3.1A Minimum requirements for CA

For inter-band carrier aggregation with one component carrier per operating band and the uplink assigned to one E-UTRA band the narrow-band blocking requirements are defined with the uplink active on the band(s) other than the band whose downlink is being tested. The UE shall meet the requirements specified in subclause 7.6.3.1 for each component carrier while all downlink carriers are active. For E-UTRA CA configurations including an operating band without uplink band or an operating band with an unpaired DL part (as noted in Table 5.5-1), the requirements for all downlinks shall be met with the single uplink carrier active in each band capable of UL operation. For E-UTRA CA configurations listed in Table 7.3.1A-0a under conditions for which reference sensitivity for the operating band being tested is N/A, the narrow-band blocking requirements of subclause 7.6.3.1A do not apply. For E-UTRA CA configurations with a component carrier assigned in Band 46, narrow-band blocking requirements do not apply in the presence of a narrow-band interferer in Band 46.

For intra-band contiguous carrier aggregation the downlink SCC(s) shall be configured at nominal channel spacing to the PCC. For FDD, the PCC shall be configured closest to the uplink band. All downlink carriers shall be active throughout the test. The uplink output power shall be set as specified in Table 7.6.3.1A-1 with the uplink configuration set according to Table 7.3.1A-1 for the applicable carrier aggregation configuration. For UE(s) supporting one uplink, the uplink configuration of the PCC shall be in accordance with Table 7.3.1-2. The UE shall fulfil the minimum requirement in presence of an interfering signal specified in Table 7.6.3.1A-1 being on either side of the aggregated signal. The throughput of each carrier shall be  $\geq 95\%$  of the maximum throughput of the reference measurement channels as specified in Annexes A.2.2, A.2.3 and A.3.2 (with one sided dynamic OCNG Pattern OP.1 FDD/TDD for the DL-signal as described in Annex A.5.1.1/A.5.2.1) with parameters specified in Table 7.6.3.1A-1. For operating bands with an unpaired DL part (as noted in Table 5.5-1), the requirements also apply for an SCC assigned in the unpaired part with parameters specified in Table 7.6.3.1A-1.

For intra-band non-contiguous carrier aggregation with one uplink carrier and two or more downlink sub-blocks, the narrow band blocking requirements are defined with the uplink configuration in accordance with Table 7.3.1A-3. For this uplink configuration, the UE shall meet the requirements for each sub-block as specified in subclauses 7.6.3.1 and 7.6.3.1A for one component carrier and two component carriers per sub-block, respectively. The requirements apply for in-gap and out-of-gap interferers while all downlink carriers are active.

Table 7.6.3.1A-1: Narrow-band blocking

Parameter	Unit	CA Bandwidth Class				
		B	C	D	E	F
P <sub>w</sub> in Transmission Bandwidth Configuration, per CC	dBm	REFSENS + CA Bandwidth Class specific value below				
		16	16 <sup>4</sup>	16	16	16
P <sub>uw</sub> (CW)	dBm	-55	-55	-55	-55	-55
F <sub>uw</sub> (offset for Δf = 15 kHz)	MHz	- F <sub>offset</sub> - 0.2 / + F <sub>offset</sub> + 0.2	- F <sub>offset</sub> - 0.2 / + F <sub>offset</sub> + 0.2	- F <sub>offset</sub> - 0.2 / + F <sub>offset</sub> + 0.2	- F <sub>offset</sub> - 0.2 / + F <sub>offset</sub> + 0.2	- F <sub>offset</sub> - 0.2 / + F <sub>offset</sub> + 0.2
F <sub>uw</sub> (offset for Δf = 7.5 kHz)	MHz					
NOTE 1: The transmitter shall be set to 4dB below P <sub>CMAX_L,C</sub> or P <sub>CMAX_L</sub> as defined in subclause 6.2.5A.						
NOTE 2: Reference measurement channel is specified in Annex A.3.2 with one sided dynamic OCNG Pattern OP.1 FDD/TDD as described in Annex A.5.1.1/A.5.2.1.						
NOTE 3: The F <sub>uw</sub> (offset) is the frequency separation of the center frequency of the carrier closest to the interferer and the center frequency of the interferer and shall be further adjusted to $\lfloor \frac{F_{\text{interferer}}}{0.015 + 0.5} \rfloor 0.015 + 0.0075$ MHz to be offset from the sub-carrier raster.						
NOTE 4: The requirement is applied for the band combinations whose component carriers' BW ≥ 5 MHz.						

For combinations of intra-band and inter-band carrier aggregation and one uplink carrier assigned to one E-UTRA band, the requirement is defined with the uplink active in a band other than that supporting the downlink(s) under test. The uplink configuration shall be in accordance with Table 7.3.1A-3 when the uplink is active in the band supporting two or more non-contiguous component carriers, Table 7.3.1A-1 when the uplink is active in a band supporting two contiguous component carriers and in accordance with Table 7.3.1-2 when the uplink is active in a band supporting one carrier per band. The downlink PCC shall be configured closer to the uplink operating band than the downlink SCC(s) when the uplink is active in band(s) supporting contiguous aggregation. For these uplink configurations, the UE shall meet the narrow-band blocking requirements for intra-band non-contiguous carrier aggregation with  $\Delta R_{\text{IBNC}} = 0$  dB for all sub-block gaps (Table 7.3.1A-3) for the two or more non-contiguous downlink sub-blocks, the requirements for intra-band contiguous carrier aggregation for the contiguously aggregated downlink carriers and for any remaining component carrier(s) the requirements specified in subclause 7.6.3. For E-UTRA CA configurations with component carriers assigned in Band 46, narrow-band blocking requirements do not apply in the presence of a narrow-band interferer in Band 46. All downlink carriers shall be active throughout the tests and the requirements for the downlinks shall be met with the single uplink carrier active in each band capable of UL operation.

### 7.6.3.1D Minimum requirements for ProSe

The relative throughput shall be  $\geq 95\%$  of the maximum throughput of the reference measurement channels as specified in Annex A.6.2 with parameters specified in Table 7.6.3.1D-1 and Table 7.6.3.1D-2.

Table 7.6.3.1D-1: Narrow-band blocking for ProSe Direct Discovery

Parameter	Unit	Channel Bandwidth					
		1.4 MHz	3 MHz	5 MHz	10 MHz	15 MHz	20 MHz
P <sub>w</sub>	dBm	P <sub>REFSENS ProSe</sub> + channel-bandwidth specific value below + P <sub>offset</sub>					
				16	13	14	16
P <sub>uw</sub> (CW)	dBm			-55	-55	-55	-55
P <sub>offset</sub>	dB			10.9	13.9	15.7	16.9
F <sub>uw</sub> (offset for Δf = 15 kHz)	MHz			2.7075	5.2125	7.7025	10.2075
F <sub>uw</sub> (offset for Δf = 7.5 kHz)	MHz						
NOTE 1: Reference measurement channel is specified in Annex A.6.2.							

**Table 7.6.3.1D-2: Narrow-band blocking for ProSe Direct Communication**

Parameter	Unit	Channel Bandwidth					
		1.4 MHz	3 MHz	5 MHz	10 MHz	15 MHz	20 MHz
$P_w$	dBm	REFSENS <sub>ProSe</sub> + channel-bandwidth specific value below					
				16	13	14	16
$P_{uw}$ (CW)	dBm			-55	-55	-55	-55
$F_{uw}$ (offset for $\Delta f = 15$ kHz)	MHz			2.7075	5.2125	7.7025	10.2075
$F_{uw}$ (offset for $\Delta f = 7.5$ kHz)	MHz						

NOTE 1: Reference measurement channel is specified in Annex A.6.2.

For the UE which supports inter-band CA configuration in Table 7.3.1-1A,  $P_{uw}$  power defined in Table 7.6.3.1D-1 and Table 7.6.3.1D-2 is increased by the amount given by  $\Delta R_{IB,c}$  in Table 7.3.1-1A.

## 7.6A Void

<Reserved for future use>

## 7.6B Blocking characteristics for UL-MIMO

For UE with two transmitter antenna connectors in closed-loop spatial multiplexing scheme, the minimum requirements in subclause 7.6 shall be met with the UL-MIMO configurations specified in Table 6.2.2B-2. For UL-MIMO, the parameter  $P_{C_{MAX,L}}$  is defined as the total transmitter power over the two transmit antenna connectors.

## 7.7 Spurious response

Spurious response is a measure of the receiver's ability to receive a wanted signal on its assigned channel frequency without exceeding a given degradation due to the presence of an unwanted CW interfering signal at any other frequency at which a response is obtained i.e. for which the out of band blocking limit as specified in subclause 7.6.2 is not met.

### 7.7.1 Minimum requirements

The throughput shall be  $\geq 95\%$  of the maximum throughput of the reference measurement channels as specified in Annexes A.2.2, A.2.3 and A.3.2 (with one sided dynamic OCNG Pattern OP.1 FDD/TDD for the DL-signal as described in Annex A.5.1.1/A.5.2.1) with parameters specified in Tables 7.7.1-1 and 7.7.1-2. For operating bands with an unpaired DL part (as noted in Table 5.5-1), the requirements only apply for carriers assigned in the paired part.

**Table 7.7.1-1: Spurious response parameters**

Rx parameter	Units	Channel bandwidth					
		1.4 MHz	3 MHz	5 MHz	10 MHz	15 MHz	20 MHz
Power in Transmission Bandwidth Configuration	dBm	REFSENS + channel bandwidth specific value below					
		6	6	6	6	7	9

NOTE 1: The transmitter shall be set to 4dB below  $P_{C_{MAX,L}}$  at the minimum uplink configuration specified in Table 7.3.1-2.

NOTE 2: Reference measurement channel is specified in Annex A.3.2 with one sided dynamic OCNG Pattern OP.1 FDD/TDD as described in Annex A.5.1.1/A.5.2.1.

NOTE 3: The REFSENS power level is specified in Table 7.3.1-1 and Table 7.3.1-1a for two and four antenna ports, respectively.

Table 7.7.1-2: Spurious response

Parameter	Unit	Level
$P_{\text{Interferer (CW)}}$	dBm	-44
$F_{\text{Interferer}}$	MHz	Spurious response frequencies

For the UE which supports inter-band CA configuration in Table 7.3.1-1A,  $P_{\text{Interferer}}$  power defined in Table 7.7.1-2 is increased by the amount given by  $\Delta R_{\text{IB,c}}$  in Table 7.3.1-1A.

### 7.7.1A Minimum requirements for CA

For inter-band carrier aggregation with one component carrier per operating band and the uplink assigned to one E-UTRA band the spurious response requirements are defined with the uplink active on the band(s) other than the band whose downlink is being tested. The throughput measured in each downlink with  $F_{\text{Interferer}}$  in Table 7.6.2.1A-0 and Table 7.6.2.1A-0a at spurious response frequencies shall be  $\geq 95\%$  of the maximum throughput of the reference measurement channels as specified in Annexes A.2.2, A.2.3 and A.3.2 (with one sided dynamic OCNG Pattern OP.1 FDD/TDD for the DL-signal as described in Annex A.5.1.1/A.5.2.1) with parameters specified in Tables 7.7.1-1 and 7.7.1-2. The UE shall meet these requirements for each component carrier while all downlink carriers are active.

For inter-band carrier aggregation with one component carrier per operating band and the uplink active in two E-UTRA bands, the spurious response requirements applicable specified above shall be met with the transmitter power for the uplink set to 7 dB below  $P_{\text{CMAX,L,c}}$  for each serving cell  $c$ .

For E-UTRA CA configurations including an operating band without uplink band or an operating band with an unpaired DL part (as noted in Table 5.5-1), the requirements for all downlinks shall be met with the single uplink carrier active in each band capable of UL operation. For E-UTRA CA configurations listed in Table 7.3.1A-0a under conditions for which reference sensitivity for the operating band being tested is N/A, the spurious response requirements of subclause 7.7.1A do not apply.

For intra-band contiguous carrier aggregation the downlink SCC(s) shall be configured at nominal channel spacing to the PCC. For FDD, the PCC shall be configured closest to the uplink band. All downlink carriers shall be active throughout the test. The uplink output power shall be set as specified in Table 7.7.1A-1 with the uplink configuration set according to Table 7.3.1A-1 for the applicable carrier aggregation configuration. For UE(s) supporting one uplink carrier, the uplink configuration of the PCC shall be in accordance with Table 7.3.1-2. The throughput of each carrier shall be  $\geq 95\%$  of the maximum throughput of the reference measurement channels as specified in Annexes A.2.2, A.2.3 and A.3.2 (with one sided dynamic OCNG Pattern OP.1 FDD/TDD for the DL-signal as described in Annex A.5.1.1/A.5.2.1) with parameters specified in Tables 7.7.1A-1 and 7.7.1A-2. For operating bands with an unpaired DL part (as noted in Table 5.5-1), the requirements also apply for an SCC assigned in the unpaired part with parameters specified in Tables 7.7.1A-1 and 7.7.1A-2.

For intra-band non-contiguous carrier aggregation with one uplink carrier and two or more downlink sub-blocks, the spurious response requirements are defined with the uplink configuration in accordance with Table 7.3.1A-3. For this uplink configuration, the UE shall meet the requirements for each sub-block as specified in subclauses 7.7.1 and 7.7.1A for one component carrier and two component carriers per sub-block, respectively. The requirements apply with all downlink carriers active.

For intra-band non-contiguous carrier aggregation with two uplink carriers and two or more downlink carriers, the spurious response requirements applicable specified above shall be met with the transmitter powers for the uplinks set to  $P_{\text{CMAX,L,c}} - 7$  dBm.

Table 7.7.1A-1: Spurious response parameters

Rx Parameter	Units	CA Bandwidth Class				
		B	C	D	E	F
Pw in Transmission Bandwidth Configuration, per CC	dBm	REFSENS + CA Bandwidth Class specific value below				
		9	9	9	9	9
NOTE 1: The transmitter shall be set to 4dB below $P_{\text{CMAX,L,c}}$ or $P_{\text{CMAX,L}}$ as defined in subclause 6.2.5A.						
NOTE 2: Reference measurement channel is specified in Annex A.3.2 with one sided dynamic OCNG Pattern OP.1 FDD/TDD as described in Annex A.5.1.1/A.5.2.1.						



Table 7.7.1A-2: Spurious response

Parameter	Unit	Level
$P_{\text{Interferer (CW)}}$	dBm	-44
$F_{\text{Interferer}}$	MHz	Spurious response frequencies

For combinations of intra-band and inter-band carrier aggregation and one uplink carrier assigned to one E-UTRA band, the requirement is defined with the uplink active in a band other than that supporting the downlink(s) under test. The uplink configuration shall be in accordance with Table 7.3.1A-3 when the uplink is active in the band supporting two or more non-contiguous component carriers, Table 7.3.1A-1 when the uplink is active in a band supporting two contiguous component carriers and in accordance with Table 7.3.1-2 when the uplink is active in a band supporting one carrier per band. The downlink PCC shall be configured closer to the uplink operating band than the downlink SCC(s) when the uplink is active in band(s) supporting contiguous aggregation. For the two or more non-contiguous component carriers within the same band,  $P_{\text{wanted}}$  in Table 7.6.2.1A-0 is set using  $\Delta R_{\text{BNC}} = 0$  dB for all sub-block gaps (Table 7.3.1A-3) while a band supporting contiguously aggregated carriers the out-of-band blocking parameters in Table 7.7.1-1 are replaced by those specified in Table 7.7.1A-1. For each downlink the UE shall meet the spurious-response requirements applicable for inter-band carrier aggregation with one component carrier per operating band. All downlink carriers shall be active throughout the tests and the requirements for the downlinks shall be met with the single uplink carrier active in each band capable of UL operation.

### 7.7.1B Minimum requirements for UL-MIMO

For UE with two transmitter antenna connectors in closed-loop spatial multiplexing scheme, the minimum requirements in Clause 7.7.1 shall be met with the UL-MIMO configurations specified in Table 6.2.2B-2. For UL-MIMO, the parameter  $P_{\text{CMAX}_L}$  is defined as the total transmitter power over the two transmit antenna connectors.

### 7.7.1D Minimum requirements for ProSe

The throughput shall be  $\geq 95\%$  of the maximum throughput of the reference measurement channels as specified in Annex A.6.2 with parameters specified in Tables 7.7.1D-1, 7.7.1D-2, and 7.7.1D-3.

Table 7.7.1D-1: Spurious response parameters for ProSe Direct Discovery

Rx parameter	Units	Channel bandwidth					
		1.4 MHz	3 MHz	5 MHz	10 MHz	15 MHz	20 MHz
Power in Transmission Bandwidth Configuration	dBm	$P_{\text{REFSENS ProSe}} + \text{channel bandwidth specific value below} + P_{\text{offset}}$					
				6	6	7	9
$P_{\text{offset}}$	dB			10.9	13.9	15.7	16.9

NOTE 1: Reference measurement channel is specified in Annex A.6.2.

Table 7.7.1D-2: Spurious response parameters for ProSe Direct Communication

Rx parameter	Units	Channel bandwidth					
		1.4 MHz	3 MHz	5 MHz	10 MHz	15 MHz	20 MHz
Power in Transmission Bandwidth Configuration	dBm	$P_{\text{REFSENS ProSe}} + \text{channel bandwidth specific value below}$					
				6	6	7	9

NOTE 1: Reference measurement channel is specified in Annex A.6.2.

**Table 7.7.1D-3: Spurious response for ProSe**

Parameter	Unit	Level
$P_{\text{Interferer (CW)}}$	dBm	-44
$F_{\text{Interferer}}$	MHz	Spurious response frequencies

For the UE which supports inter-band CA configuration in Table 7.3.1-1A,  $P_{\text{Interferer}}$  power defined in Table 7.7.1D-3 is increased by the amount given by  $\Delta R_{\text{IB,c}}$  in Table 7.3.1-1A.

### 7.7.1F Minimum requirements for UE category NB1 and NB2

The category NB1 and NB2 UE throughput shall be  $\geq 95\%$  of the maximum throughput of the reference measurement channel as specified in Annex A.3.2 with parameters specified in Tables 7.7.1F-1.

**Table 7.7.1F-1: Spurious response parameters for UE category NB1 and NB2**

Parameter	Unit	Level
$P_{\text{signal}}$	dBm	REFSENS+6
$P_{\text{Interferer (CW)}}$	dBm	-44
$F_{\text{Interferer}}$	MHz	Spurious response frequencies
Number of spurious response frequencies		24 (in OOB range 1, 2, 3)
NOTE 1: Reference measurement channel is specified in Annex A.3.2.		
NOTE 2: The REFSENS power level is specified in 7.3.1F.1-1.		
NOTE 3: OOB range 1, 2, 3 refers to Table 7.6.2.1F-1.		

### 7.7.1G Minimum requirements for V2X

The throughput shall be  $\geq 95\%$  of the maximum throughput of the reference measurement channels as specified in Annex A.8.2 with parameters specified in Tables 7.7.1G-1.

**Table 7.7.1G-1: Spurious response parameters**

Rx parameter	Units	Channel bandwidth					
		1.4 MHz	3 MHz	5 MHz	10 MHz	15 MHz	20 MHz
Power in Transmission Bandwidth Configuration	dBm	$P_{\text{REFSENS\_V2X}}$ + channel bandwidth specific value below					
					6		9
NOTE 1: Reference measurement channel is specified in Annex A.8.2.							

**Table 7.7.1G-2: Spurious response**

Parameter	Unit	Level
$P_{\text{Interferer (CW)}}$	dBm	-44
$F_{\text{Interferer}}$	MHz	Spurious response frequencies

When UE is configured for simultaneous E-UTRA V2X sidelink and E-UTRA downlink reception for inter-band E-UTRA V2X / E-UTRA bands specified in Table 5.5G-2, the requirements in subclause 7.7.1G apply for the E-UTRA V2X sidelink reception and the requirements in subclause 7.7.1 apply for the E-UTRA downlink reception while all downlink carriers are active.

For intra-band contiguous multi-carrier operation, the V2X UE throughput shall be  $\geq 95\%$  of the maximum throughput of the reference measurement channels as specified in Annex A.8.2 with parameters specified in Table 7.7.1G-3 and Table 7.7.1G-4.

**Table 7.7.1G-3: Spurious response parameters for intra-band contiguous multi-carrier for V2X UE**

Rx Parameter	Units	V2X Bandwidth Class				
		B	C/ C <sub>1</sub>	D	E	F
Pw in Transmission Bandwidth Configuration, per CC	dBm	REFSENS + V2X Bandwidth Class specific value below				
		9	9			
NOTE 1: The requirement is applied for multi-carrier intra-band con-current receptions when 2 carrier transmissions are activated at the same time.						

**Tables 7.7.1G-4: Spurious response for intra-band contiguous multi-carrier for V2X UE**

Parameter	Unit	Level
P <sup>Interferer</sup> (CW)	dBm	-44
F <sup>Interferer</sup>	MHz	Spurious response frequencies
NOTE 1: The requirement is applied for multi-carrier intra-band con-current receptions when 2 carrier transmissions are activated at the same time.		

## 7.8 Intermodulation characteristics

Intermodulation response rejection is a measure of the capability of the receiver to receive a wanted signal on its assigned channel frequency in the presence of two or more interfering signals which have a specific frequency relationship to the wanted signal.

### 7.8.1 Wide band intermodulation

The wide band intermodulation requirement is defined following the same principles using modulated E-UTRA carrier and CW signal as interferer.

#### 7.8.1.1 Minimum requirements

The throughput shall be  $\geq 95\%$  of the maximum throughput of the reference measurement channels as specified in Annexes A.2.2, A.2.3 and A.3.2 (with one sided dynamic OCNG Pattern OP.1 FDD/TDD for the DL-signal as described in Annex A.5.1.1/A.5.2.1) with parameters specified in Table 7.8.1.1 for the specified wanted signal mean power in the presence of two interfering signals. For operating bands with an unpaired DL part (as noted in Table 5.5-1), the requirements only apply for carriers assigned in the paired part.

Table 7.8.1.1-1: Wide band intermodulation

Rx Parameter	Units	Channel bandwidth					
		1.4 MHz	3 MHz	5 MHz	10 MHz	15 MHz	20 MHz
Power in Transmission Bandwidth Configuration	dBm	REFSENS + channel bandwidth specific value below					
		12	8	6	6	7	9
$P_{\text{Interferer 1 (CW)}}$	dBm	-46					
$P_{\text{Interferer 2 (Modulated)}}$	dBm	-46					
$BW_{\text{Interferer 2}}$		1.4	3	5			
$F_{\text{Interferer 1 (Offset)}}$	MHz	-BW/2 - 2.1 / +BW/2 + 2.1	-BW/2 - 4.5 / +BW/2 + 4.5	-BW/2 - 7.5 / +BW/2 + 7.5			
$F_{\text{Interferer 2 (Offset)}}$	MHz	$2 \cdot F_{\text{Interferer 1}}$					
NOTE 1: The transmitter shall be set to 4dB below $P_{\text{CMAX,L}}$ at the minimum uplink configuration specified in Table 7.3.1-2 with $P_{\text{CMAX,L}}$ as defined in subclause 6.2.5.							
NOTE 2: Reference measurement channel is specified in Annex A.3.2 with one sided dynamic OCNG Pattern OP.1 FDD/TDD as described in Annex A.5.1.1/A.5.2.1.							
NOTE 3: The modulated interferer consists of the Reference measurement channel specified in Annex A.3.2 with one sided dynamic OCNG Pattern OP.1 FDD/TDD as described in Annex A.5.1.1/A.5.2.1 with set-up according to Annex C.3.1. The interfering modulated signal is 5MHz E-UTRA signal as described in Annex D for channel bandwidth $\geq 5$ MHz.							
NOTE 4: The REFSENS power level is specified in Table 7.3.1-1 and Table 7.3.1-1a for two and four antenna ports, respectively.							
NOTE 5: For DL category M1 and M2 UE, the reference sensitivity for category M1 in table 7.3.1E-3 and category M2 in Table 7.3.1E-8 should be used as REFSENS for the power in Transmission Bandwidth Configuration.							
NOTE6: For DL category M1 and M2 UE, the parameters for the applicable channel bandwidth apply, and BW refers to the corresponding channel bandwidth.							

For the UE which supports inter band CA configuration in Table 7.3.1-1A,  $P_{\text{Interferer1}}$  and  $P_{\text{Interferer2}}$  powers defined in Table 7.8.1.1-1 are increased by the amount given by  $\Delta R_{\text{B,c}}$  in Table 7.3.1-1A.

### 7.8.1A Minimum requirements for CA

For inter-band carrier aggregation with one component carrier per operating band and the uplink assigned to one E-UTRA band the wide band intermodulation requirements are defined with the uplink active on the band(s) other than the band whose downlink is being tested. The UE shall meet the requirements specified in subclause 7.8.1.1 for each component carrier while all downlink carriers are active. For E-UTRA CA configurations including an operating band without uplink band or an operating band with an unpaired DL part (as noted in Table 5.5-1), the requirements for all downlinks shall be met with the single uplink carrier active in each band capable of UL operation. For a component carrier configured in Band 46 or Band 49, the requirements specified in subclause 7.8.1.1 are replaced by the requirements in Table 7.8.1-1A-0.

Table 7.8.1.1A-0: Wide band intermodulation

E-UTRA band	Rx Parameter	Units	Channel bandwidth					
			1.4 MHz	3 MHz	5 MHz	10 MHz	15 MHz	20 MHz
46	Power in Transmission Bandwidth Configuration	dBm	REFSENS + channel bandwidth specific value below					
					6		9	
	$P_{\text{Interferer 1 (CW)}}$	dBm	-46					
	$P_{\text{Interferer 2 (Modulated)}}$	dBm	-46					
	$BW_{\text{Interferer 2}}$	MHz				20		20
	$F_{\text{Interferer 1 (Offset)}}$	MHz				-BW/2-30 / +BW/2+30		-BW/2-30 / +BW/2+30
$F_{\text{Interferer 2 (Offset)}}$	MHz	$2 \cdot F_{\text{Interferer 1}}$						
49	Power in Transmission Bandwidth Configuration	dBm				6		6
	$P_{\text{Interferer 1 (CW)}}$	dBm	-46					
	$P_{\text{Interferer 2 (Modulated)}}$	dBm	-46					
	$BW_{\text{Interferer 2}}$	MHz				10		20
	$F_{\text{Interferer 1 (Offset)}}$	MHz				-BW/2-15 / +BW/2+15		-BW/2-30 / +BW/2+30
	$F_{\text{Interferer 2 (Offset)}}$	MHz	$2 \cdot F_{\text{Interferer 1}}$					
NOTE 1: The transmitter shall be set to 4dB below $P_{\text{CMAX,L}}$ at the minimum uplink configuration specified in Table 7.3.1-2 with $P_{\text{CMAX,L}}$ as defined in subclause 6.2.5.								
NOTE 2: Reference measurement channel is specified in Annex A.3.2 with one sided dynamic OCNG Pattern OP.1 FDD/TDD/FS3 as described in Annex A.5.1.1/A.5.2.1/A.5.4.1.								
NOTE 3: The modulated interferer consists of the Reference measurement channel specified in Annex A.3.2 with one sided dynamic OCNG Pattern OP.1 FDD/TDD as described in Annex A.5.1.1/A.5.2.1.								

For E-UTRA CA configurations listed in Table 7.3.1A-0a under conditions for which reference sensitivity for the operating band being tested is N/A, the wideband intermodulation requirements of subclause 7.8.1A do not apply.

For intra-band contiguous carrier aggregation the downlink SCC(s) shall be configured at nominal channel spacing to the PCC. For FDD, the PCC shall be configured closest to the uplink band. All downlink carriers shall be active throughout the test. The uplink output power shall be set as specified in Table 7.8.1A-1 with the uplink configuration set according to Table 7.3.1A-1 for the applicable carrier aggregation configuration. For UE(s) supporting one uplink carrier, the uplink configuration of the PCC shall be in accordance with Table 7.3.1-2. The UE shall fulfil the minimum requirement in presence of an interfering signal specified in Table 7.8.1A-1 being on either side of the aggregated signal. The throughput of each carrier shall be  $\geq 95\%$  of the maximum throughput of the reference measurement channels as specified in Annexes A.2.2, A.2.3 and A.3.2 (with one sided dynamic OCNG Pattern OP.1 FDD/TDD for the DL-signal as described in Annex A.5.1.1/A.5.2.1) with parameters specified in Table 7.8.1A-1. For operating bands with an unpaired DL part (as noted in Table 5.5-1), the requirements also apply for an SCC assigned in the unpaired part with parameters specified in Tables 7.8.1A-1.

Table 7.8.1A-1: Wide band intermodulation

Rx parameter	Units	CA Bandwidth Class				
		B	C	D	E	F
$P_w$ in Transmission Bandwidth Configuration, per CC	dBm	REFSENS + CA Bandwidth Class specific value below				
		9	12	13.8	15	16
$P_{\text{Interferer 1}}$ (CW)	dBm	-46				
$P_{\text{Interferer 2}}$ (Modulated)	dBm	-46				
$BW_{\text{Interferer 2}}$	MHz	5	5	5	5	5
$F_{\text{Interferer 1}}$ (Offset)	MHz	$-F_{\text{offset}}-7.5$ / $+ F_{\text{offset}}+7.5$	$-F_{\text{offset}}-7.5$ / $+ F_{\text{offset}}+7.5$	$-F_{\text{offset}}-7.5$ / $+ F_{\text{offset}}+7.5$	$-F_{\text{offset}}-7.5$ / $+ F_{\text{offset}}+7.5$	$-F_{\text{offset}}-7.5$ / $+ F_{\text{offset}}+7.5$
$F_{\text{Interferer 2}}$ (Offset)	MHz	$2 \cdot F_{\text{Interferer 1}}$				
NOTE 1: The transmitter shall be set to 4dB below $P_{\text{CMAX\_Lc}}$ or $P_{\text{CMAX\_L}}$ as defined in subclause 6.2.5A.						
NOTE 2: Reference measurement channel is specified in Annex A.3.2 with one sided dynamic OCNG Pattern OP.1 FDD/TDD as described in Annex A.5.1.1/A.5.2.1.						
NOTE 3: The modulated interferer consists of the Reference measurement channel specified in Annex A.3.2 with one sided dynamic OCNG Pattern OP.1 FDD/TDD as described in Annex A.5.1.1/A.5.2.1 with set-up according to Annex C.3.1.						
NOTE 4: The interfering modulated signal is 5MHz E-UTRA signal as described in Annex D for channel bandwidth $\geq 5$ MHz;						
NOTE 5: The $F_{\text{Interferer 1}}$ (offset) is the frequency separation of the center frequency of the carrier closest to the interferer and the center frequency of the CW interferer and $F_{\text{Interferer 2}}$ (offset) is the frequency separation of the center frequency of the carrier closest to the interferer and the center frequency of the modulated interferer.						

For intra-band non-contiguous carrier aggregation with one uplink carrier and two or more downlink sub-blocks, the wide band intermodulation requirements are defined with the uplink configuration in accordance with Table 7.3.1A-3. For this uplink configuration, the UE shall meet the requirements for each sub-block as specified in subclauses 7.8.1.1 and in this subclause for one component carrier and two or more component carriers per sub-block, respectively. The requirements apply for out-of-gap interferers while all downlink carriers are active.

For combinations of intra-band and inter-band carrier aggregation and one uplink carrier assigned to one E-UTRA band, the requirement is defined with the uplink active in a band other than that supporting the downlink(s) under test. The uplink configuration shall be in accordance with Table 7.3.1A-3 when the uplink is active in the band supporting two or more non-contiguous component carriers, Table 7.3.1A-1 when the uplink is active in a band supporting two contiguous component carriers and in accordance with Table 7.3.1-2 when the uplink is active in a band supporting one carrier per band. For these uplink configurations, the UE shall meet the wide-band intermodulation requirements for intra-band non-contiguous carrier aggregation with  $\Delta R_{\text{IBNC}} = 0$  dB for all sub-block gaps (Table 7.3.1A-3) for the two or more non-contiguous downlink sub-blocks, the requirements for intra-band contiguous carrier aggregation for the contiguously aggregated downlink carriers and for any remaining component carrier(s) the requirements specified in subclause 7.8.1. For contiguously aggregated component carriers configured in Band 46, the said requirements for intra-band contiguous carrier aggregation of two or more downlink carriers are replaced by requirements in Table 7.8.1A-2. For non-contiguously aggregated component carriers configured in Band 46, the said requirements are applied to each sub-block for out-of-gap interferers. For the sub-block with a single component carrier, the requirement is replaced by Table 7.8.1.1A-0. For the sub-block with two or more contiguous component carriers, the requirement is replaced by Table 7.8.1.1A-2. All downlink carriers shall be active throughout the tests and the requirements for the downlinks shall be met with the single uplink carrier active in each band capable of UL operation.

Table 7.8.1A-2: Wide band intermodulation

E-UTRA Band	Rx parameter	Units	CA Bandwidth Class				
			B	C	D	E	F
46	Power per CC in Aggregated Transmission Bandwidth Configuration	dBm	REFSENS + CA Bandwidth Class specific value below				
			12	13.8	15		
	$P_{\text{Interferer 1 (CW)}}$	dBm	-46				
	$P_{\text{Interferer 2 (Modulated)}}$		-46				
	$BW_{\text{Interferer 2}}$	MHz		20	20	20	
	$F_{\text{Interferer 1 (Offset)}}$	MHz		$-F_{\text{offset}-30}$ / $+ F_{\text{offset}+30}$	$-F_{\text{offset}-30}$ / $+ F_{\text{offset}+30}$	$-F_{\text{offset}-30}$ / $+ F_{\text{offset}+30}$	
$F_{\text{Interferer 2 (Offset)}}$	$2 \cdot F_{\text{Interferer 1}}$						
NOTE 1: The transmitter shall be set to 4dB below $P_{\text{CMAX,L,C}}$ or $P_{\text{CMAX,L}}$ as defined in subclause 6.2.5A.							
NOTE 2: Reference measurement channel is specified in Annex A.3.2 with one sided dynamic OCNG Pattern OP.1 FDD/TDD/FS3 as described in Annex A.5.1.1/A.5.2.1/A.5.4.1.							
NOTE 3: The modulated interferer consists of the Reference measurement channel specified in Annex A.3.2 with one sided dynamic OCNG Pattern OP.1 FDD/TDD/FS3 as described in Annex A.5.1.1/A.5.2.1/A.5.4.1 with set-up according to Annex C.3.1.							
NOTE 4: The interfering modulated signal is 20 MHz E-UTRA signal as described in Annex D interference setting 2;							
NOTE 5: The $F_{\text{Interferer 1 (offset)}}$ is the frequency separation of the center frequency of the carrier closest to the interferer and the center frequency of the CW interferer and $F_{\text{Interferer 2 (offset)}}$ is the frequency separation of the center frequency of the carrier closest to the interferer and the center frequency of the modulated interferer.							

### 7.8.1B Minimum requirements for UL-MIMO

For UE(s) with two transmitter antenna connectors in closed-loop spatial multiplexing scheme, the minimum requirements in subclause 7.8.1 shall be met with the UL-MIMO configurations specified in Table 6.2.2B-2. For UL-MIMO, the parameter  $P_{\text{CMAX,L}}$  is defined as the total transmitter power over the two transmit antenna connectors.

### 7.8.1D Minimum requirements for ProSe

The throughput shall be  $\geq 95\%$  of the maximum throughput of the reference measurement channels as specified in Annex A.6.2 with parameters specified in Table 7.8.1D-1, Table 7.8.1D-2, and Table 7.8.1D-3 for the specified wanted signal mean power in the presence of two interfering signals

Table 7.8.1D-1: Wide band intermodulation parameters for ProSe Direct Discovery

Rx parameter	Units	Channel bandwidth					
		1.4 MHz	3 MHz	5 MHz	10 MHz	15 MHz	20 MHz
$P_{\text{offset}}$	dB			10.9	13.9	15.7	16.9

Table 7.8.1D-2: Wide band intermodulation for ProSe Direct Communication

Rx parameter	Units	Channel bandwidth					
		1.4 MHz	3 MHz	5 MHz	10 MHz	15 MHz	20 MHz
$P_{\text{offset}}$	dB			0	0	0	0

Table 7.8.1D-3: Wide band intermodulation for ProSe

Rx Parameter	Units	Channel bandwidth					
		1.4 MHz	3 MHz	5 MHz	10 MHz	15 MHz	20 MHz
Power in Transmission Bandwidth Configuration	dBm	$P_{\text{REFSENS, ProSe}} + \text{channel bandwidth specific value below} + P_{\text{Offset}}$					
		12	8	6	6	7	9
$P_{\text{Interferer 1 (CW)}}$	dBm	-46					
$P_{\text{Interferer 2 (Modulated)}}$	dBm	-46					
$BW_{\text{Interferer 2}}$		1.4	3	5			
$F_{\text{Interferer 1 (Offset)}}$	MHz	-BW/2 - 2.1	-BW/2 - 4.5	-BW/2 - 7.5			
		+BW/2 + 2.1	+BW/2 + 4.5	+BW/2 + 7.5			
$F_{\text{Interferer 2 (Offset)}}$	MHz	$2 \cdot F_{\text{Interferer 1}}$					
NOTE 1: Reference measurement channel is specified in Annex A.6.2							
NOTE 2: The interferer is QPSK modulated PUSCH containing data and reference symbols. Normal cyclic prefix is used. The data content shall be uncorrelated to the wanted signal and modulated according to clause 5 of TS36.211							

For the UE which supports inter band CA configuration in Table 7.3.1-1A,  $P_{\text{Interferer1}}$  and  $P_{\text{Interferer2}}$  powers defined in Table 7.8.1D-3 are increased by the amount given by  $\Delta R_{\text{IB,c}}$  in Table 7.3.1-1A.

### 7.8.1F Minimum requirements for category NB1 and NB2

The throughput shall be  $\geq 95\%$  of the maximum throughput of the reference measurement channel as specified in Annex A.3.2 with parameters specified in Table 7.8.1F-1 for the specified wanted signal mean power in the presence of two interfering signals.

Table 7.8.1F-1: Wide band intermodulation for category NB1 and NB2

Parameters for wideband intermodulation	
Category NB1 or NB2 signal power	REFSENS + 12 dB
CW interferer signal power	- 46 dBm
1.4 MHz E-UTRA interferer signal power	- 46 dBm
CW interferer offset	$\pm 2.2$ MHz
1.4 MHz E-UTRA interferer offset	$\pm 4.4$ MHz

### 7.8.1G Minimum requirements

The throughput shall be  $\geq 95\%$  of the maximum throughput of the reference measurement channels as specified in Annex A.8.2 with parameters specified in Table 7.8.1G-1 for the specified wanted signal mean power in the presence of two interfering signals



Table 7.8.1G-1: Wide band intermodulation

Rx Parameter	Units	Channel bandwidth					
		1.4 MHz	3 MHz	5 MHz	10 MHz	15 MHz	20 MHz
Power in Transmission Bandwidth Configuration	dBm	P <sub>REFSENS_V2X</sub> + channel bandwidth specific value below					
					6		9
P <sub>Interferer 1 (CW)</sub>	dBm	-46					
P <sub>Interferer 2 (Modulated)</sub>	dBm	-46					
BW <sub>Interferer 2</sub>					10		10
F <sub>Interferer 1 (Offset)</sub>	MHz				-BW/2 – 15 / +BW/2 + 15		-BW/2 – 15 / +BW/2 + 15
F <sub>Interferer 2 (Offset)</sub>	MHz	2 * F <sub>Interferer 1</sub>					
NOTE 1: Reference measurement channel is specified in Annex A.8.2							
NOTE 2: The interferer is QPSK modulated PUSCH containing data and reference symbols. Normal cyclic prefix is used. The data content shall be uncorrelated to the wanted signal and modulated according to clause 5 of TS36.211							

When UE is configured for simultaneous E-UTRA V2X sidelink and E-UTRA downlink reception for inter-band E-UTRA V2X / E-UTRA bands specified in Table 5.5G-2, the requirements in subclause 7.8.1G apply for the E-UTRA V2X sidelink reception and the requirements in subclause 7.8.1 apply for the E-UTRA downlink reception while all downlink carriers are active.

For intra-band contiguous multi-carrier operation, the V2X UE throughput shall be  $\geq 95\%$  of the maximum throughput of the reference measurement channels as specified in Annex A.8.2 with parameters specified in Table 7.8.1G-2 for the specified wanted signal mean power in the presence of two interfering signals.

Table 7.8.1G-2: Wide band intermodulation for intra-band contiguous multi-carrier for V2X UE

Rx parameter	Units	V2X Bandwidth Class				
		B	C/ C <sub>1</sub>	D	E	F
P <sub>w</sub> in Transmission Bandwidth Configuration, per CC	dBm	REFSENS + V2X Bandwidth Class specific value below				
		9	12			
P <sub>Interferer 1 (CW)</sub>	dBm	-46				
P <sub>Interferer 2 (Modulated)</sub>	dBm	-46				
BW <sub>Interferer 2</sub>	MHz	10	10			
F <sub>Interferer 1 (Offset)</sub>	MHz	-F <sub>offset</sub> +15 / + F <sub>offset</sub> +15	-F <sub>offset</sub> -15 / + F <sub>offset</sub> +15			
F <sub>Interferer 2 (Offset)</sub>	MHz	2 * F <sub>Interferer 1</sub>				
NOTE 1: The requirement is applied for multi-carrier intra-band con-current receptions when 2 carrier transmissions are activated at the same time.						

## 7.8.2 Void

## 7.9 Spurious emissions

The spurious emissions power is the power of emissions generated or amplified in a receiver that appear at the UE antenna connector.

## 7.9.1 Minimum requirements

The power of any narrow band CW spurious emission shall not exceed the maximum level specified in Table 7.9.1-1

**Table 7.9.1-1: General receiver spurious emission requirements**

Frequency band	Measurement bandwidth	Maximum level	NOTE
$30\text{MHz} \leq f < 1\text{GHz}$	100 kHz	-57 dBm	
$1\text{GHz} \leq f \leq 12.75\text{GHz}$	1 MHz	-47 dBm	
$12.75\text{GHz} \leq f \leq 5^{\text{th}}$ harmonic of the upper frequency edge of the DL operating band in GHz	1 MHz	-47 dBm	1
$12.75\text{GHz} - 26\text{GHz}$	1 MHz	-47dBm	3
NOTE 1: Applies only for Band 22, Band 42, Band 43, Band 48 and Band 49			
NOTE 2: Unused PDCCH resources are padded with resource element groups with power level given by PDCCH_RA/RB as defined in Annex C.3.1.			
NOTE 3: Applies for Band 46 and Band 47			

In addition, for a V2X UE operating in Region 1, the power of any spurious emission shall not exceed the levels specified in Table 7.9.1-2.

**Table 7.9.1-2: Additional RX spurious emissions limits in Region 1**

Frequency Range	Maximum Level	Measurement bandwidth	NOTE
$5795\text{MHz} \leq f < 5815\text{MHz}$	-65 dBm (EIRP)	1 MHz	
NOTE: The EIRP requirement is converted to conducted requirement depend on the supported post antenna connector gain $G_{\text{post connector}}$ declared by the UE following the principle described in annex I. The additional Rx spurious emission limits, only apply when the network signaling value NS_33 or NS_34 is indicated.			

### 7.9.1A Minimum requirements

For E-UTRA CA configurations including an operating band without uplink band (as noted in Table 5.5-1), the power of any narrow band CW spurious emission shall not exceed the maximum level specified in Table 7.9.1A-1.

**Table 7.9.1A-1: General receiver spurious emission requirements**

Frequency band	Measurement bandwidth	Maximum level	NOTE
$30\text{MHz} \leq f < 1\text{GHz}$	100 kHz	-57 dBm	
$1\text{GHz} \leq f \leq 12.75\text{GHz}$	1 MHz	-47 dBm	
$12.75\text{GHz} \leq f \leq 26\text{GHz}$	1 MHz	-47 dBm	3
NOTE 1: Unused PDCCH resources are padded with resource element groups with power level given by PDCCH_RA/RB as defined in Annex C.3.1.			
NOTE 2: The requirements apply when the UE is configured for carrier aggregation but is not transmitting.			
NOTE 3: Applies only for Band 46			

## 7.10 Receiver image

### 7.10.1 Void

#### 7.10.1A Minimum requirements for CA

Receiver image rejection is a measure of a receiver's ability to receive the E-UTRA signal on one component carrier while it is also configured to receive an adjacent aggregated carrier. Receiver image rejection ratio is the ratio of the wanted received power on a sub-carrier being measured to the unwanted image power received on the same sub-carrier when both sub-carriers are received with equal power at the UE antenna connector.

For intra-band contiguous carrier aggregation the UE shall fulfil the minimum requirement specified in Table 7.10.1A-1 for all values of aggregated input signal up to  $-22$  dBm.

**Table 7.10.1A-1: Receiver image rejection**

Rx parameter	Units	CA bandwidth class					
		A	B	C	D	E	F
Receiver image rejection	dB		25	25	25	25	25

#### 7.10.1G Minimum requirements for V2X Communication

Receiver image rejection is a measure of a receiver's ability to receive the E-UTRA V2X signal on one component carrier while it is also configured to receive another aggregated carrier. Receiver image rejection ratio is the ratio of the wanted received power on a sub-carrier being measured to the unwanted image power received on the same sub-carrier when both sub-carriers are received with equal power at the UE antenna connector.

For intra-band contiguous multi-carrier operation, the UE shall fulfil the minimum requirement specified in Table 7.10.1G-1 for all values of aggregated input signal.

**Table 7.10.1G-1: Receiver image rejection**

Rx parameter	Units	V2X Bandwidth Class					
		A	B	C/ C <sub>1</sub>	D	E	F
Receiver image rejection	dB		30	30			
NOTE 1: The requirement is applied for multi-carrier intra-band con-current receptions when 2 carrier transmissions are activated at the same time.							

## 8 Performance requirement

This clause contains performance requirements for the physical channels specified in TS 36.211 [4]. The performance requirements for the UE in this clause are specified for the measurement channels specified in Annex A.3, the propagation conditions in Annex B and the downlink channels in Annex C.3.2.

NOTE: For the requirements in the following sections, similar Release 8 and 9 requirements apply for time domain measurements restriction under colliding CRS.

### 8.1 General

#### 8.1.1 Receiver antenna capability

The performance requirements are based on UE(s) that utilize one or more antenna receivers.

For all test cases, the SNR is defined as

$$SNR = \frac{\sum_{j=1}^{N_{RX}} \hat{E}_s^{(j)}}{\sum_{j=1}^{N_{oc}} N_{oc}^{(j)}}$$

where  $N_{RX}$  denotes the number of receiver antenna connectors and the superscript receiver antenna connector  $j$ . The above SNR definition assumes that the REs are not precoded. The SNR definition does not account for any gain which can be associated to the precoding operation. The relative power of physical channels transmitted is defined in Table C.3.2-1. The SNR requirement applies for the UE categories and CA capabilities given for each test.

For enhanced performance requirements type A, the SINR is defined as

$$SINR = \frac{\sum_{j=1}^{N_{RX}} \hat{E}_s^{(j)}}{\sum_{j=1}^{N_{oc}} N_{oc}^{(j)}}$$

where  $N_{RX}$  denotes the number of receiver antenna connectors and the superscript receiver antenna connector  $j$ . The above SINR definition assumes that the REs are not precoded. The SINR definition does not account for any gain which can be associated to the precoding operation. The relative power of physical channels transmitted is defined in Table C.3.2-1. The SINR requirement applies for the UE categories given for each test.

For the performance requirements specified in this clause, it is assumed that  $N_{RX}=2$  unless otherwise stated.

**Table 8.1.1-1: Void**

## 8.1.1.1 Simultaneous unicast and MBMS operations

## 8.1.1.2 Dual-antenna receiver capability in idle mode

## 8.1.2 Applicability of requirements

## 8.1.2.1 Applicability of requirements for different channel bandwidths

In Clause 8 the test cases may be defined with different channel bandwidth to verify the same target FRC conditions with the same propagation conditions, correlation matrix and antenna configuration.

Test cases defined for 5MHz channel bandwidth that reference this clause are applicable to UEs that support only Band 31, 72, 73, 87 and/or 88.

## 8.1.2.2 Definition of CA capability

The definition with respect to CA capabilities for 2CCs is given as in Table 8.1.2.2-1. The definition with respect to CA capabilities for 3CCs is given in Table 8.1.2.2-3.

**Table 8.1.2.2-1: Definition of CA capability with 2DL CCs**

CA Capability	CA Capability Description
CA2_C	Intra-band contiguous CA
CA2_A2	Inter-band CA (two bands)
CA2_N2	Intra-band non-contiguous CA (with two sub-blocks)
NOTE 1: CA2_C corresponds to E-UTRA CA configurations and bandwidth combination sets defined in Table 5.6A.1-1 for 2 DL CCs. CA2_A2 corresponds to E-UTRA CA configurations and bandwidth combination sets defined in Table 5.6A.1-2 for 2 DL CCs. CA2_N2 corresponds to E-UTRA CA configurations and bandwidth combination sets defined in Table 5.6A.1-3 for 2 DL CCs.	

The supported testable aggregated CA bandwidth combinations for 2CCs for each CA capability are listed in Table 8.1.2.2-2.

**Table 8.1.2.2-2: Supported testable aggregated CA bandwidth combinations for different CA capability with 2DL CCs**

CA Capability	Bandwidth combination for FDD CA	Bandwidth combination for TDD CA	Bandwidth combination for TDD-FDD CA	Bandwidth combination for CA with LAA SCell(s)
CA2_C	5+5MHz, 5+10MHz, 5+15MHz, 10+10MHz, 20+20MHz	20+20MHz, 15+20MHz	NA	NA
CA2_A2	10+10MHz, 20+5MHz, 10+15MHz, 10+20MHz, 15+20MHz, 20+20MHz	20+20MHz	10(FDD)+20(TDD)MHz, 15(FDD)+20(TDD)MHz, 20(FDD)+20(TDD)MHz	20(FDD)+20(LAA)MHz, 10(FDD)+20(LAA)MHz, 15(FDD)+20(LAA)MHz, 20(TDD)+20(LAA)MHz
CA2_N2	5+10MHz, 10+10MHz, 10+20MHz, 20+20MHz	20+20MHz	NA	NA
NOTE 1: This table is only for information and applicability and test rules of CA performance requirements are specified in 8.1.2.3 and 9.1.1.2.				

**Table 8.1.2.2-3: Definition of CA capability with 3 DL CCs**

CA Capability	CA Capability Description
CA3_C	Intra-band contiguous CA
CA3_A2	Inter-band CA (two bands)
CA3_A3	Inter-band CA (three bands)
CA3_N2	Intra-band non-contiguous CA (with two sub-blocks)
NOTE 1: CA3_C corresponds to E-UTRA CA configurations and bandwidth combination sets defined in Table 5.6A.1-1 for 3 DL CCs. CA3_A2 corresponds to E-UTRA CA configurations and bandwidth combination sets defined in Table 5.6A.1-2 for 3 DL CCs. CA3_A3 corresponds to E-UTRA CA configurations and bandwidth combination sets defined in and Table 5.6A.1-2a for 3 DL CCs. CA3_N2 corresponds to E-UTRA CA configurations and bandwidth combination sets defined in Table 5.6A.1-3 for 3 DL CCs.	

The supported testable largest aggregated CA bandwidth combinations for 3CCs for each CA capability are listed in Table 8.1.2.2-4.

**Table 8.1.2.2-4: Supported largest aggregated CA bandwidth combinations for different CA capability with 3 CCs**

CA capability	Bandwidth combination for FDD CA	Bandwidth combination for TDD CA	Bandwidth combination for TDD-FDD CA	Bandwidth combination for CA with LAA SCell(s)
CA3_C	NA	20+20+20MHz	NA	NA
CA3_A2	5+5+10MHz, 5+10+10MHz, 5+5+20MHz, 10+10+10MHz, 5+10+20MHz, 5+15+20MHz, 10+10+20MHz, 10+20+20MHz, 15+20+20MHz, 20+20+20MHz	15+20+20MHz, 20+20+20MHz	10(FDD)+20(TDD)+20(TDD)MHz, 15(FDD)+20(TDD)+20(TDD)MHz, 20(FDD)+20(TDD)+20(TDD)MHz	10(FDD)+ 2×20(LAA)MHz, 15(FDD)+ 2×20(LAA)MHz, 20(FDD)+ 2×20(LAA)MHz, 20(TDD)+ 2×20(LAA)MHz
CA3_A3	10+10+20MHz, 10+15+15MHz, 10+15+20MHz, 10+20+20MHz, 15+15+20MHz, 15+20+20MHz, 20+20+20MHz	NA	2×20(FDD)+20(TDD)MHz, 20(FDD)+ 2×20(TDD)MHz, 20(FDD)+15(FDD)+20(TDD)MHz, 20(FDD)+10(FDD)+20(TDD)MHz, 2×15(FDD)+20(TDD)MHz	NA
CA3_N2	NA	20+20+20MHz	NA	NA
NOTE 1: This table is only for information and applicability and test rules of CA performance requirements are specified in 8.1.2.3 and 9.1.1.2.				

Table 8.1.2.2-5: Definition of CA capability with 4 DL CCs

CA Capability	CA Capability Description
CA4_C	Intra-band contiguous CA
CA4_A2	Inter-band CA (two bands)
CA4_A3	Inter-band CA (three bands)
CA4_A4	Inter-band CA (four bands)
CA4_N2	Intra-band non-contiguous CA (with two sub-blocks)
NOTE 1: CA4_C corresponds to E-UTRA CA configurations and bandwidth combination sets defined in Table 5.6A.1-1 for 3 DL CCs. CA4_A2 corresponds to E-UTRA CA configurations and bandwidth combination sets defined in Table 5.6A.1-2 for 3 DL CCs. CA4_A3 corresponds to E-UTRA CA configurations and bandwidth combination sets defined in and Table 5.6A.1-2a for 3 DL CCs. CA4_A4 corresponds to E-UTRA CA configurations and bandwidth combination sets defined in and Table 5.6A.1-2b for 4 DL CCs CA4_N2 corresponds to E-UTRA CA configurations and bandwidth combination sets defined in Table 5.6A.1-3 for 3 DL CCs.	

The supported testable largest aggregated CA bandwidth combinations for 4CCs for each CA capability are listed in Table 8.1.2.2-6.

Table 8.1.2.2-6: Supported largest aggregated CA bandwidth combinations for different CA capability with 4 CCs

CA capability	Bandwidth combination for FDD CA	Bandwidth combination for TDD CA	Bandwidth combination for TDD-FDD CA	Bandwidth combination for CA with LAA SCell(s)
CA4_C	NA	20+20+20+20MHz	NA	NA
CA4_A2	24x20MHz 10+3x20MHz 2x10+2x20MHz 210+5+2x20MHz 2x5+2x20MHz 3x10+20MHz 4x10MHz	20+20+20+20MHz 15+20+20+20MHz	20(FDD)+3x20(TDD)MHz 2x20(FDD)+2x20(TDD)MHz 10(FDD)+3x20(TDD)MHz 2x10(FDD)+2x20(TDD)MHz 2x10(FDD)+20+15(TDD)MHz	10(FDD)+ 3x20(LAA)MHz, 15(FDD)+ 3x20(LAA)MHz, 20(FDD)+ 3x20(LAA)MHz, 20(TDD)+ 3x20(LAA)MHz
CA4_A3	24x20MHz 15+3x20MHz 210+3x20MHz 2x10+2x20MHz 5+10+2x20MHz 2x5+2x20MHz 3x10+20MHz 25+2x10+20MHz 2x5+10+20MHz	NA	20(FDD)+3x20(TDD)MHz 2x20(FDD)+2x20(TDD)MHz, 3x20(FDD)+20(TDD)MHz 20(FDD)+15(FDD)+2x20(TDD)MHz, 2x15(FDD)+2x20(TDD)MHz 10(FDD)+20(FDD)+2x20(TDD)MHz 10(FDD)+3x20(TDD)MHz 10(FDD)+15(FDD)+2x20(TDD)MHz 2x10(FDD)+2x20(TDD)MHz	NA
CA4_A4	24x20MHz 15+3x20MHz 210+3x20MHz 2x15+2x20MHz 10+15+2x20MHz 22x10+2x20MHz	NA	3x20(FDD)+20(TDD)MHz 2x20(FDD)+15(FDD)+20(TDD)MHz, 2x15(FDD)+20(FDD)+20(TDD)MHz 2x20(FDD)+10(FDD)+20(TDD)MHz 10(FDD)+20(FDD)+2x20(TDD)MHz 10(FDD)+15(FDD)+20(FDD)+20(TDD)MHz	NA
CA4_N2	NA	20+20+20+20MHz	NA	NA
NOTE 1: This table is only for information and applicability and test rules of CA performance requirements are specified in 8.1.2.3 and 9.1.1.2.				

Table 8.1.2.2-7: Definition of CA capability with 5 DL CCs

CA Capability	CA Capability Description
CA5_C	Intra-band contiguous CA
CA5_A2	Inter-band CA (two bands)
CA5_A3	Inter-band CA (three bands)
CA5_A4	Inter-band CA (four bands)
CA5_A5	Inter-band CA (five bands)
CA5_N2	Intra-band non-contiguous CA (with two sub-blocks)
NOTE 1: CA5_C corresponds to E-UTRA CA configurations and bandwidth combination sets defined in Table 5.6A.1-1 for 5 DL CCs. CA5_A2 corresponds to E-UTRA CA configurations and bandwidth combination sets defined in Table 5.6A.1-2 for 5 DL CCs. CA5_A3 corresponds to E-UTRA CA configurations and bandwidth combination sets defined in and Table 5.6A.1-2a for 5 DL CCs. CA5_A4 corresponds to E-UTRA CA configurations and bandwidth combination sets defined in and Table 5.6A.1-2b for 5 DL CCs. CA5_A5 corresponds to E-UTRA CA configurations and bandwidth combination sets defined in and Table 5.6A.1-2c for 5 DL CCs. CA5_N2 corresponds to E-UTRA CA configurations and bandwidth combination sets defined in Table 5.6A.1-3 for 5 DL CCs.	

The supported testable largest aggregated CA bandwidth combinations for 5CCs for each CA capability are listed in Table 8.1.2.2-8.

Table 8.1.2.2-8: Supported largest aggregated CA bandwidth combinations for different CA capability with 5 CCs

CA capability	Bandwidth combination for FDD CA	Bandwidth combination for TDD CA	Bandwidth combination for TDD-FDD CA	Bandwidth combination for CA with LAA SCell(s)
CA5_C	NA	5x20MHz	NA	NA
CA5_A2	5x20MHz 3x20+2x10MHz 20+4x10MHz	5x20MHz 15+4x20MHz	2x20(FDD)+3x20(TDD) 20(FDD)+4x20(TDD)MHz 2x10(FDD)+3x20(TDD)MH	10(FDD)+ 4x20(LAA)MHz, 15(FDD)+ 4x20(LAA)MHz, 20(FDD)+ 4x20(LAA)MHz, 20(TDD)+ 4x20(LAA)MHz
CA5_A3	5x20MHz 10+4x20MHz 2x10+3x20MHz 5+10+3x20MHz 3x10+2x20MHz 4x10+20MHz	NA	3x20(FDD)+2x20(TDD)MHz 20(FDD)+4x20(TDD)MHz 2x20(FDD)+3x20(TDD)MHz 10(FDD)+4x20(TDD)MHz	NA
CA5_A4	5x20MHz 15+4x20MHz 10+4x20MHz 2x10+3x20MHz 3x10+2x20MHz	NA	3x20(FDD)+2x20(TDD)MHz 15+2x20(FDD)+2x20(TDD)MHz 0+2x20(FDD)+2x20(TDD)MHz 2x15+20(FDD)+2x20(TDD)MHz 10+15+20(FDD)+2x20(TDD)MHz 10+20(FDD)+3x20MHz	NA
CA5_A5	5x20MHz	NA	4x20(FDD)+20(TDD)MHz	NA
CA5_N2	NA	5x20MHz	NA	NA
NOTE 1: This table is only for information and applicability and test rules of CA performance requirements are specified in 8.1.2.3 and 9.1.1.2.				



**Table 8.1.2.2-9: Definition of CA capability with 6 DL CCs**

CA Capability	CA Capability Description
CA6_C	Intra-band contiguous CA
CA6_A2	Inter-band CA (two bands)
CA6_A3	Inter-band CA (three bands)
CA6_A4	Inter-band CA (four bands)
CA6_A5	Inter-band CA (five bands)
CA6_N2	Intra-band non-contiguous CA (with two sub-blocks)
NOTE 1: CA6_C corresponds to E-UTRA CA configurations and bandwidth combination sets defined in Table 5.6A.1-1 for 6 DL CCs. CA5_A2 corresponds to E-UTRA CA configurations and bandwidth combination sets defined in Table 5.6A.1-2 for 6 DL CCs. CA5_A3 corresponds to E-UTRA CA configurations and bandwidth combination sets defined in and Table 5.6A.1-2a for 6 DL CCs. CA5_A4 corresponds to E-UTRA CA configurations and bandwidth combination sets defined in and Table 5.6A.1-2b for 6 DL CCs CA5_A5 corresponds to E-UTRA CA configurations and bandwidth combination sets defined in and Table 5.6A.1-2c for 6 DL CCs CA5_N2 corresponds to E-UTRA CA configurations and bandwidth combination sets defined in Table 5.6A.1-3 for 6 DL CCs.	

The supported testable largest aggregated CA bandwidth combinations for 6CCs for each CA capability are listed in Table 8.1.2.2-10.

**Table 8.1.2.2-10: Supported largest aggregated CA bandwidth combinations for different CA capability with 6 CCs**

CA capability	Bandwidth combination for FDD CA	Bandwidth combination for TDD CA	Bandwidth combination for TDD-FDD CA	Bandwidth combination for CA with LAA SCell(s)
CA6_C	NA	NA	NA	NA
CA6_A2	NA	6x20MHz	20(FDD)+5x20(TDD)MHz 2x20(FDD)+4x20(TDD)MHz	10(FDD)+ 5x20(LAA)MHz, 15(FDD)+ 5x20(LAA)MHz, 20(FDD)+ 5x20(LAA)MHz, 20(TDD)+ 5x20(LAA)MHz
CA6_A3	NA	NA	20(FDD)+5x20(TDD)MHz 2x20(FDD)+4x20(TDD)MHz	NA
CA6_A4	6x20MHz	NA	20(FDD)+5x20(TDD)MHz 2x20(FDD)+4x20(TDD)MHz	NA
CA6_A5	NA	NA	NA	NA
CA6_N2	NA	NA	NA	NA
NOTE 1: This table is only for information and applicability and test rules of CA performance requirements are specified in 8.1.2.3 and 9.1.1.2.				

**Table 8.1.2.2-11: Definition of CA capability with 7 DL CCs**

CA Capability	CA Capability Description
CA7_C	Intra-band contiguous CA
CA7_A2	Inter-band CA (two bands)
CA7_A3	Inter-band CA (three bands)
CA7_A4	Inter-band CA (four bands)
CA7_A5	Inter-band CA (five bands)
CA7_N2	Intra-band non-contiguous CA (with two sub-blocks)
NOTE 1: CA6_C corresponds to E-UTRA CA configurations and bandwidth combination sets defined in Table 5.6A.1-1 for 7 DL CCs. CA5_A2 corresponds to E-UTRA CA configurations and bandwidth combination sets defined in Table 5.6A.1-2 for 7 DL CCs. CA5_A3 corresponds to E-UTRA CA configurations and bandwidth combination sets defined in and Table 5.6A.1-2a for 7 DL CCs. CA5_A4 corresponds to E-UTRA CA configurations and bandwidth combination sets defined in and Table 5.6A.1-2b for 7 DL CCs CA5_A5 corresponds to E-UTRA CA configurations and bandwidth combination sets defined in and Table 5.6A.1-2c for 7 DL CCs CA5_N2 corresponds to E-UTRA CA configurations and bandwidth combination sets defined in Table 5.6A.1-3 for 7 DL CCs.	

The supported testable largest aggregated CA bandwidth combinations for 7CCs for each CA capability are listed in Table 8.1.2.2-12.

**Table 8.1.2.2-12: Supported largest aggregated CA bandwidth combinations for different CA capability with 7 CCs**

CA capability	Bandwidth combination for FDD CA	Bandwidth combination for TDD CA	Bandwidth combination for TDD-FDD CA	Bandwidth combination for CA with LAA SCell(s)
CA7_C	NA	NA	NA	NA
CA7_A2	NA	7×20MHz	20(FDD)+6×20(TDD)MHz 2x20(FDD)+5x20(TDD)MHz	10(FDD)+ 6×20(LAA)MHz, 15(FDD)+ 6×20(LAA)MHz, 20(FDD)+ 6×20(LAA)MHz, 20(TDD)+ 6×20(LAA)MHz
CA7_A3	NA	NA	20(FDD)+6×20(TDD)MHz 2x20(FDD)+5x20(TDD)MHz	NA
CA7_A4	7×20MHz	NA	20(FDD)+6×20(TDD)MHz 2x20(FDD)+5x20(TDD)MHz	NA
CA7_A5	NA	NA	NA	NA
CA7_N2	NA	NA	NA	NA
NOTE 1: This table is only for information and applicability and test rules of CA performance requirements are specified in 8.1.2.3 and 9.1.1.2.				

For test cases with more than one component carrier, "Fraction of Maximum Throughput" in the performance requirement refers to the ratio of the sum of throughput values of all component carriers to the sum of the nominal maximum throughput values of all component carriers, unless otherwise stated.

### 8.1.2.2A Definition of dual connectivity capability

The definition with respect to dual connectivity capabilities for configurations with 2CCs is given as in Table 8.1.2.2A-1. The definition with respect to dual connectivity capabilities for configurations with 3CCs is given as in Table 8.1.2.2A-3.

**Table 8.1.2.2A-1: Definition of dual connectivity capability with 2DL CCs**

Dual connectivity Capability	Dual connectivity capability Description
DC_A_2	Inter-band dual connectivity (two bands)
NOTE 1: DC_A_2 corresponds to E-UTRA dual connectivity configurations and bandwidth combination sets defined for inter-band dual connectivity (two bands) as specified in 5.6C.	

The supported testable dual connectivity bandwidth combinations for 2CCs for each dual connectivity capability are listed in Table 8.1.2.2A-2.

**Table 8.1.2.2A-2: Supported testable dual connectivity bandwidth combinations for different dual connectivitys capability with 2DL CCs**

Dual connectivity capability	Bandwidth combination for FDD dual connectivity	Bandwidth combination for TDD dual connectivity	Bandwidth combination for TDD-FDD dual connectivity
DC_A_2	10+10MHz, 10+20MHz, 15+15MHz, 15+20MHz, 20+20MHz, 15+5MHz	20+20MHz	20(FDD)+20(TDD)MHz
NOTE 1: This table is only for information and applicability and test rules of dual connectivity performance requirements are specified in 8.1.2.3A			

**Table 8.1.2.2A-3: Definition of dual connectivity capability with 3DL CCs**

Dual connectivity Capability	Dual connectivity capability Description
DC_A_3	Inter-band dual connectivity (three bands)
NOTE 1: DC_A_3 corresponds to E-UTRA dual connectivity configurations and bandwidth combination sets defined for inter-band dual connectivity (three bands) as specified in 5.6C.	

The supported testable dual connectivity bandwidth combinations for 3CCs for each dual connectivity capability are listed in Table 8.1.2.2A-4.

**Table 8.1.2.2A-4: Supported testable dual connectivity bandwidth combinations for different dual connectivitys capability with 3DL CCs**

Dual connectivity capability	Bandwidth combination for FDD dual connectivity	Bandwidth combination for TDD dual connectivity
DC_A_3	20+20+15MHz, 20+15+15MHz	NA
NOTE 1: This table is only for information and applicability and test rules of dual connectivity performance requirements are specified in 8.1.2.3A		

### 8.1.2.3 Applicability and test rules for different CA configurations and bandwidth combination sets

The performance requirement for CA UE demodulation tests in Clause 8 are defined independent of CA configurations and bandwidth combination sets specified in Clause 5.6A. For UEs supporting different CA configurations and bandwidth combination sets, the applicability and test rules are defined for the tests for 2 DL CCs in Table 8.1.2.3-1 and 3 or more DL CCs in Table 8.2.2.3-2. For simplicity, CA configuration below refers to combination of CA configuration and bandwidth combination set.

Table 8.1.2.3-1: Applicability and test rules for CA UE demodulation tests with 2 DL CCs

Tests	CA capability where the tests apply	CA configuration from the selected CA capability where the tests apply	CA Bandwidth combination to be tested in priority order
CA tests with 2CCs in Clause 8.2.1.1.1, 8.2.1.4.3	Any one of the supported CA capabilities	Any one of the supported FDD CA configurations	10+10 MHz, 20+20 MHz, 5+5 MHz, 10MHz+5MHz, 15MHz+5MHz
CA tests with 2CCs in Clause 8.2.1.3.1	Each supported CA capability	Any one of the supported FDD CA configurations in each CA capability	10+10 MHz, 20+20 MHz, 5+5 MHz, 10MHz+5MHz, other combinations
CA tests with 2CCs in Clause 8.2.1.3.1A, 8.7.1, 8.2.1.9.2	Any one of the supported CA capabilities with largest aggregated CA bandwidth combination	Any one of the supported FDD CA configurations with largest aggregated CA bandwidth combination	Largest aggregated CA bandwidth combination
CA tests with 2CCs in Clause 8.2.1.7.1	CA_C	Supported FDD intra-band contiguous CA configurations covering the lowest and highest operating bands	Largest aggregated CA bandwidth combinations
CA tests with 2CCs in Clause 8.2.2.1.1, 8.2.2.4.3, 8.2.2.9.2	Any one of the supported CA capabilities with largest aggregated CA bandwidth combination	Any one of the supported TDD CA configurations with largest aggregated CA bandwidth combination	Largest aggregated CA bandwidth combination
CA tests with 2CCs in Clause 8.2.2.3.1	Each supported CA capability	Any one of the supported TDD CA configurations in each CA capability with largest aggregated CA bandwidth combination	Largest aggregated CA bandwidth combination
CA tests with 2CCs in Clause 8.2.2.3.1A, 8.7.2	Any one of the supported CA capabilities with largest aggregated CA bandwidth	Any one of the supported TDD CA configurations with largest aggregated CA bandwidth combination	Largest aggregated CA bandwidth combination
CA tests with 2CCs in 8.2.2.7.1	CA_C	Supported TDD intra-band contiguous CA configurations covering the lowest and highest operating bands	Largest aggregated CA bandwidth combinations
CA tests with 2CCs in Clause 8.2.1.8.1	CA_N	CA_3A-3A defined in Table 5.6A.1-3	10+10 MHz
CA tests with 2CCs in Clause 8.2.2.8.1	CA2_C	CA_41C defined in Table 5.6A.1-1	20+20 MHz
CA tests in Clause 8.2.1.10.1 (NOTE 4)	CA2_C	CA_1C and CA_3C defined in Table 5.6A.1-1	Largest aggregated CA bandwidth combinations
<p>NOTE 1: The applicability and test rules are specified in this table, unless otherwise stated.</p> <p>NOTE 2: Number of the supported bandwidth combinations to be tested from each selected CA configuration is 1.</p> <p>NOTE 3: A single Uplink CC is configured for all tests.</p> <p>NOTE 4: For FDD carriers with minimum channel spacing, UE only supports the carriers in the following scenarios:</p> <ul style="list-style-type: none"> <li>- Inter-band CA with <math>\geq 3</math> CCs, where Band 1 is with 1 CC and normal spacing (PCell) and Band 2 is with 2 intra-band contiguous CCs and minimum channel spacing (SCell), or</li> <li>- Band 1 is configured with 1CC and normal spacing, and UE accesses the CC on Band 1, and then handed over to Band 2 with 2 intra-band contiguous CCs and minimum channel spacing.</li> </ul>			

**Table 8.1.2.3-2: Applicability and test rules for CA UE demodulation tests with 3 or more DL CCs**

Tests	CA capability where the tests apply	CA configuration from the selected CA capability where the tests apply	CA Bandwidth combination to be tested in priority order
CA tests with 3 or more CCs in Clause 8.2.1.1.1, 8.2.1.4.3, 8.7.1, 8.2.1.9.1	Any one of the supported CA capabilities with largest aggregated CA bandwidth combination	Any one of the supported FDD CA configurations with largest aggregated CA bandwidth combination	Largest aggregated CA bandwidth combination
CA tests with 3 or more CCs in Clause 8.2.1.3.1	Each supported CA capability	Any one of the supported FDD CA configurations in each CA capability with largest aggregated CA bandwidth combination	Largest aggregated CA bandwidth combination
CA tests with 3 or more CCs in Clause 8.2.2.1.1, 8.2.2.4.3, 8.7.2, 8.2.2.9.2	Any one of the supported CA capabilities with largest aggregated CA bandwidth combination	Any one of the supported TDD CA configurations with largest aggregated CA bandwidth combination	Largest aggregated CA bandwidth combination
CA tests with 3 or more CCs in Clause 8.2.2.3.1	Each supported CA capability	Any one of the supported TDD CA configurations in each CA capability with largest aggregated CA bandwidth combination	Largest aggregated CA bandwidth combination
CA tests with 3CCs in Clause 8.2.2.8.1	CA3_C	CA_41D defined in Table 5.6A.1-1	20+20+20 MHz
NOTE 1: The applicability and test rules are specified in this table, unless otherwise stated. NOTE 2: Number of the supported bandwidth combinations to be tested from each selected CA configuration is 1. NOTE 3: A single Uplink CC is configured for all tests			

### 8.1.2.3A Applicability and test rules for different dual connectivity configuration and bandwidth combination set

The performance requirement for dual connectivity UE demodulation tests in Clause 8 are defined independent of dual connectivity configurations and bandwidth combination sets specified in Clause 5.6C.1. For UEs supporting different dual connectivity configurations and bandwidth combination sets, the applicability and test rules are defined for the tests for the configurations with 2CCs in Table 8.1.2.3A-1 and 3 DL CCs in Table 8.1.2.3A-2. For simplicity, dual connectivity configuration below refers to combination of dual connectivity configuration and bandwidth set.

Both CA performance requirements and dual connectivity performance requirements are applied for dual connectivity capable UE.

**Table 8.1.2.3A-1: Applicability and test rules for dual connectivity UE demodulation tests with 2DL CCs**

Tests	Dual connectivity capability where the tests apply	Dual connectivity configuration from the selected CA capability where the tests apply	Dual connectivity Bandwidth combination to be tested in priority order
Dual connectivity test with 2CCs in Clause 8.2.1.4.3A, 8.7.6	Any one of the supported dual connectivity capabilities with largest aggregated dual connectivity bandwidth combination	Any one of the supported FDD dual connectivity configurations with the largest aggregated dual connectivity bandwidth combination	Largest dual connectivity aggregated bandwidth combination
Dual connectivity test with 2CCs in Clause 8.2.2.4.3A, 8.7.7	Any one of the supported dual connectivity capabilities with largest aggregated dual connectivity bandwidth combination	Any one of the supported TDD dual connectivity configurations with the largest aggregated dual connectivity bandwidth combination	Largest dual connectivity aggregated bandwidth combination
Dual connectivity test with TDD FDD 2CCs in Clause 8.2.3.4, 8.7.8	Any one of the supported dual connectivity capabilities with largest aggregated dual connectivity bandwidth combination	Any one of the supported TDD FDD dual connectivity configurations with the largest aggregated dual connectivity bandwidth combination	Largest dual connectivity aggregated bandwidth combination

NOTE 1: The applicability and test rules are specified in this table, unless otherwise stated.  
NOTE 2: Number of the supported bandwidth combinations to be tested from each selected DC or CA configuration is 1.

**Table 8.1.2.3A-2: Applicability and test rules for dual connectivity UE demodulation tests with 3DL CCs**

Tests	Dual connectivity capability where the tests apply	Dual connectivity configuration from the selected CA capability where the tests apply	Dual connectivity Bandwidth combination to be tested in priority order
Dual connectivity test with 3CCs in Clause 8.2.1.4.3A, 8.7.6	Any one of the supported dual connectivity capabilities with largest aggregated dual connectivity bandwidth combination	Any one of the supported FDD dual connectivity configurations with the largest aggregated dual connectivity bandwidth combination	Largest dual connectivity aggregated bandwidth combination

NOTE 1: The applicability and test rules are specified in this table, unless otherwise stated.  
NOTE 2: Number of the supported bandwidth combinations to be tested from each selected DC or CA configuration is 1.

### 8.1.2.3B Applicability and test rules for different TDD-FDD CA configurations and bandwidth combination sets

The performance requirement for TDD-FDD CA UE demodulation tests in Clause 8 are defined independent of CA configurations and bandwidth combination sets specified in Clause 5.6A.1. For UEs supporting different CA configurations and bandwidth combination sets, the applicability and test rules are defined for the tests for 2 DL TDD-FDD CA in Table 8.1.2.3B-1 and in Table 8.1.2.3B-2 for 3 or more DL TDD-FDD CA. For simplicity, CA configuration below refers to combination of CA configuration and bandwidth combination set.

**Table 8.1.2.3B-1: Applicability and test rules for CA UE demodulation tests for TDD-FDD CA with 2 DL CCs**

Tests	CA capability where the tests apply	CA configuration from the selected CA capability where the tests apply	CA Bandwidth combination to be tested in priority order
CA tests with 2CCs in Clause 8.2.3.1.1, 8.2.3.2.1A, 8.2.3.3.1, 8.7.5.1, 8.2.3.5.1	Any one of the supported CA capabilities with largest aggregated CA bandwidth combination	Any one of the supported TDD-FDD CA configurations with FDD PCell with largest aggregated CA bandwidth combination	Largest aggregated CA bandwidth combination
CA tests with 2CCs in Clause 8.2.3.2.1	Each supported CA capability	Any one of the supported TDD-FDD CA configurations with FDD PCell in each CA capability with largest aggregated CA bandwidth combination	Largest aggregated CA bandwidth combination
CA tests with 2CCs in Clause 8.2.3.1.2, 8.2.3.2.2A, 8.2.3.3.2, 8.7.5.2, 8.2.3.5.2	Any one of the supported CA capabilities with largest aggregated CA bandwidth combination	Any one of the supported TDD-FDD CA configurations with TDD PCell with largest aggregated CA bandwidth combination	Largest aggregated CA bandwidth combination
CA tests with 2CCs in Clause 8.2.3.2.2	Each supported CA capability	Any one of the supported TDD-FDD CA configurations with TDD PCell in each CA capability with largest aggregated CA bandwidth combination	Largest aggregated CA bandwidth combination

NOTE 1: The applicability and test rules are specified in this table, unless otherwise stated.  
NOTE 2: Number of the supported bandwidth combinations to be tested from each selected CA configuration is 1.  
NOTE 3: A single Uplink CC is configured for all tests.

**Table 8.1.2.3B-2: Applicability and test rules for CA UE demodulation tests for TDD-FDD CA with 3 or more DL CCs**

Tests	CA capability where the tests apply	CA configuration from the selected CA capability where the tests apply	CA Bandwidth combination to be tested in priority order
CA tests with 3CCs, 4CCs, 5CCs in Clause 8.2.3.1.1, 8.2.3.2.1A, 8.2.3.3.1, 8.7.5.1	Any one of the supported CA capabilities with largest aggregated CA bandwidth combination	Any one of the supported TDD-FDD CA configurations with FDD PCell with largest aggregated CA bandwidth combination	Largest aggregated CA bandwidth combination
CA tests with 3CCs, 4CCs, 5CCs in Clause 8.2.3.2.1	Each supported CA capability	Any one of the supported TDD-FDD CA configurations with FDD PCell in each CA capability with largest aggregated CA bandwidth combination	Largest aggregated CA bandwidth combination
CA tests with 3CCs, 4CCs, 5CCs in Clause 8.2.3.1.2, 8.2.3.2.2A, 8.2.3.3.2, 8.7.5.2	Any one of the supported CA capabilities with largest aggregated CA bandwidth combination	Any one of the supported TDD-FDD CA configurations with TDD PCell with largest aggregated CA bandwidth combination	Largest aggregated CA bandwidth combination
CA tests with 3CCs, 4CCs, 5CCs in Clause 8.2.3.2.2	Each supported CA capability	Any one of the supported TDD-FDD CA configurations with TDD PCell in each CA capability with largest aggregated CA bandwidth combination	Largest aggregated CA bandwidth combination

NOTE 1: The applicability and test rules are specified in this table, unless otherwise stated.  
NOTE 2: Number of the supported bandwidth combinations to be tested from each selected CA configuration is 1.  
NOTE 3: A single Uplink CC is configured for all tests.

### 8.1.2.3C Applicability and test rules for SDR tests for 4Rx capable UEs

For FDD single carrier or CA, UE is required to fulfill SDR tests specified in section 8.7.9. For TDD single carrier or CA, UE is required to fulfill SDR tests specified in section 8.7.10. For TDD-FDD CA, UE is required to fulfill SDR test in section 8.7.11.

For FDD DC, UE is required to fulfill SDR tests specified in section 8.7.13. For TDD DC, UE is required to fulfill SDR tests specified in section 8.7.14. For TDD-FDD DC, UE is required to fulfill SDR test in section 8.7.15.

For single carrier or CA SDR tests, CA configuration, bandwidth combination and MIMO layer on each CC is determined by following procedure.

- Select one CA bandwidth combination among all supported CA configurations with bandwidth combination and MIMO layer on each CC that leads to largest equivalent aggregated bandwidth among all CA bandwidth combinations supported by UE. Equivalent aggregated bandwidth is defined as

$$B_{agg} = \prod_{i=0}^{N-1} R_i B_i$$

where  $N$  is number of CCs,  $R_i \in \{2,4\}$  and  $B_i \in \{5,10,15,20\}$  is MIMO layer and bandwidth of CC  $i$ .

- When there are multiple sets of {CA configuration, bandwidth combination, MIMO layer} with same largest aggregated bandwidth, select one among sets with largest number of 4 layer CCs.
- The procedure applies also for single carrier using operating band instead of CA configuration, and bandwidth instead of bandwidth combination.

For DC SDR tests, DC configuration, bandwidth combination and MIMO layer on each CC is determined by following procedure.

- Select one DC bandwidth combination among all supported DC configurations with bandwidth combination and MIMO layer on each CC that leads to largest equivalent aggregated bandwidth among all DC bandwidth combinations supported by UE. Equivalent aggregated bandwidth is defined as

$$B_{agg} = \prod_{i=0}^{N-1} R_i B_i$$

where  $N$  is number of CCs,  $R_i \in \{2,4\}$  and  $B_i \in \{5,10,15,20\}$  is MIMO layer and bandwidth of CC  $i$ .

- When there are multiple sets of {DC configuration, bandwidth combination, MIMO layer} with same largest aggregated bandwidth, select one among sets with largest number of 4 layer CCs.

For UEs with no supported 4Rx RF bands the applicability rule in 8.1.2.3C is not applied for SDR tests.

### 8.1.2.3D Applicability and test rules for different CA with LAA SCell(s) configurations and bandwidth combination sets

The performance requirement for CA with LAA SCell(s) UE demodulation tests in Clause 8 are defined independent of CA configurations and bandwidth combination sets specified in Clause 5.6A.1. For UEs supporting different CA with LAA SCell(s) configurations and bandwidth combination sets, the applicability and test rules are defined for the tests for 2 DL CA with LAA SCell(s) in Table 8.1.2.3D-1 and in Table 8.1.2.3D-2 for 3 or more DL CA with LAA SCell(s). For simplicity, CA configuration below refers to combination of CA with LAA SCell(s) configuration and bandwidth combination set.



**Table 8.1.2.3D-1: Applicability and test rules for CA UE demodulation tests for CA with LAA SCell(s) with 2 DL CCs**

Tests	CA capability where the tests apply	CA configuration from the selected CA capability where the tests apply	CA Bandwidth combination to be tested in priority order
CA tests with 2CCs in Clause 8.2.4.1.1, 8.3.3.1.1	Any one of the supported CA capabilities with largest aggregated CA bandwidth combination	Any one of the supported CA with LAA SCell(s) configurations with FDD PCell with largest aggregated CA bandwidth combination	Largest aggregated CA bandwidth combination
CA tests with 2CCs in Clause 8.2.4.1.2, 8.3.3.1.2	Any one of the supported CA capabilities with largest aggregated CA bandwidth combination	Any one of the supported CA with LAA SCell(s) configurations with TDD PCell with largest aggregated CA bandwidth combination	Largest aggregated CA bandwidth combination

NOTE 1: The applicability and test rules are specified in this table, unless otherwise stated.  
NOTE 2: Number of the supported bandwidth combinations to be tested from each selected CA configuration is 1.  
NOTE 3: A single Uplink CC is configured for all tests.

**Table 8.1.2.3D-2: Applicability and test rules for CA UE demodulation tests for CA with LAA SCell(s) with 3 or more DL CCs**

Tests	CA capability where the tests apply	CA configuration from the selected CA capability where the tests apply	CA Bandwidth combination to be tested in priority order
CA tests with 2CCs in Clause 8.2.4.1.1, 8.3.3.1.1	Any one of the supported CA capabilities with largest aggregated CA bandwidth combination	Any one of the supported CA with LAA SCell(s) configurations with FDD PCell with largest aggregated CA bandwidth combination	Largest aggregated CA bandwidth combination
CA tests with 2CCs in Clause 8.2.4.1.2, 8.3.3.1.2	Any one of the supported CA capabilities with largest aggregated CA bandwidth combination	Any one of the supported CA with LAA SCell(s) configurations with TDD PCell with largest aggregated CA bandwidth combination	Largest aggregated CA bandwidth combination

NOTE 1: The applicability and test rules are specified in this table, unless otherwise stated.  
NOTE 2: Number of the supported bandwidth combinations to be tested from each selected CA configuration is 1.  
NOTE 3: A single Uplink CC is configured for all tests.

### 8.1.2.3E Applicability and test rules for SDR tests for 8Rx capable UEs

UE with support of 8Rx RF bands is required to fulfill the specified SDR tests for 8Rx test in section 8.7.17.

For single carrier or CA SDR tests, CA configuration, bandwidth combination and MIMO layer on each CC is determined by following procedure.

- Select the set(s) of {CA configuration, bandwidth combination, MIMO layer} among all the supported CA configurations that leads to the largest equivalent aggregated bandwidth which does not cause the transport block bits within a TTI to exceed the capability of the category of UE under test when the defined reference channel applies on each CC. The equivalent aggregated bandwidth is defined as

$$B_{agg} = \sum_{i=0}^{N-1} a(R_i)R_iB_i$$

where  $N$  is the number of CCs,  $R_i \in \{2, 4, 8\}$  and  $B_i \in \{5, 10, 15, 20\}$  are MIMO layer and bandwidth of CC  $i$ , and  $a(R_i) = 1$  for  $R_i = 2, 4$  and  $a(R_i) = 0.75$  for  $R_i = 8$

- The procedure applies also for single carrier using operating band instead of CA configuration, and bandwidth instead of bandwidth combination.

#### 8.1.2.4 Test coverage for different number of component carriers

For FDD tests specified in 8.2.1.1.1, 8.2.1.3.1, 8.2.1.4.3, and 8.7.1, if corresponding CA tests are tested, the test coverage can be considered fulfilled without executing single carrier tests.

For TDD tests specified in 8.2.2.1.1, 8.2.2.3.1, 8.2.2.4.3, and 8.7.2, if corresponding CA tests are tested, the test coverage can be considered fulfilled without executing single carrier tests.

For TDD FDD tests specified in 8.2.3.1, 8.2.3.2, 8.2.3.3, 8.2.3.5, and 8.7.5, if corresponding TDD FDD CA tests are tested, the test coverage can be considered fulfilled without executing both FDD and TDD single carrier tests.

For FDD CA tests specified in 8.2.1.1.1, 8.2.1.4.3, 8.7.1, 8.13.1.1.1 and 8.13.1.2.1, among all supported CA capabilities, if corresponding CA tests with the largest number of CCs supported by the UE are tested, the test coverage can be considered fulfilled without executing the CA tests with less than the largest number of CCs supported by the UE.

For FDD CA tests specified in 8.2.1.3.1, for each supported CA capability, if corresponding CA tests with the largest number of CCs supported by the UE are tested, the test coverage can be considered fulfilled without executing the CA tests with less than the largest number of CCs supported by the UE.

For TDD CA tests specified in 8.2.2.1.1, 8.2.2.4.3, 8.7.2, 8.13.2.1.1 and 8.13.2.2.1, among all supported CA capabilities, if corresponding CA tests with the largest number of CCs supported by the UE are tested, the test coverage can be considered fulfilled without executing the CA tests with less than the largest number of CCs supported by the UE.

For TDD CA tests specified in 8.2.2.3.1, for each supported CA capability, if corresponding CA tests with the largest number of CCs supported by the UE are tested, the test coverage can be considered fulfilled without executing the CA tests with less than the largest number of CCs supported by the UE.

For TDD FDD CA tests specified in 8.2.3.1, 8.2.3.3, 8.7.5, 8.13.3.1 and 8.13.3.2, among all supported CA capabilities, if corresponding CA tests with the largest number of CCs supported by the UE are tested, the test coverage can be considered fulfilled without executing the TDD FDD CA tests with less than the largest number of CCs supported by the UE.

For TDD FDD CA tests specified in 8.2.3.2 and 8.2.3.5, for each supported CA capability, if corresponding CA tests with the largest number of CCs supported by the UE are tested, the test coverage can be considered fulfilled without executing the TDD FDD CA tests with less than the largest number of CCs supported by the UE.

For FDD CA power imbalance tests specified in 8.2.1.7.1, if they are tested with FDD intra-band contiguous CA configurations with 2 DL CCs, the test coverage can be considered fulfilled with FDD intra-band contiguous CA configurations with 3 or more DL CCs supported by the UE.

For TDD CA power imbalance tests specified in 8.2.2.7.1, if they are tested with TDD intra-band contiguous CA configurations with 2 DL CCs, the test coverage can be considered fulfilled with TDD intra-band contiguous CA configurations with 3 or more DL CCs supported by the UE.

For FDD DC tests specified in 8.2.1.4.3A, 8.7.6 and 8.13.1.1.2, among all supported DC capabilities, if corresponding DC tests with the largest number of CCs supported by the UE are tested, the test coverage can be considered fulfilled without executing the DC tests with less than the largest number of CCs supported by the UE.

For TDD DC tests specified in 8.2.2.4.3A, 8.7.7 and 8.13.2.1.2, among all supported DC capabilities, if corresponding DC tests with the largest number of CCs supported by the UE are tested, the test coverage can be considered fulfilled without executing the DC tests with less than the largest number of CCs supported by the UE.

For TDD FDD DC tests specified in 8.2.3.4, 8.7.8 and 8.13.3.5, among all supported DC capabilities, if corresponding DC tests with the largest number of CCs supported by the UE are tested, the test coverage can be considered fulfilled without executing the DC tests with less than the largest number of CCs supported by the UE.

For LAA SCell(s) with FDD PCell tests specified in 8.2.4.1.1 and 8.3.3.1.1, for each supported CA capability, if corresponding CA with LAA SCell(s) tests with the largest number of CCs supported by the UE are tested, the test coverage can be considered fulfilled without executing the CA with LAA SCell(s) tests with less than the largest number of CCs supported by the UE.

For LAA SCell(s) with TDD PCell tests specified in 8.2.4.1.2 and 8.3.3.1.2, for each supported CA capability, if corresponding CA with LAA SCell(s) tests with the largest number of CCs supported by the UE are tested, the test coverage can be considered fulfilled without executing the CA with LAA SCell(s) tests with less than the largest number of CCs supported by the UE.

#### 8.1.2.5 Applicability of performance requirements for Type B receiver

For TM10 capable UE, if corresponding tests specified in 8.3.1.1F, 8.3.2.1G, 9.3.8.3 are tested, the test coverage can be considered fulfilled without executing the tests specified in 8.3.1.1C, 8.3.2.1D, 9.3.8.2. For a UE which does not have TM10 capability, the tests specified in sections 8.3.1.1C, 8.3.2.1D, 9.3.8.2 should be used.

#### 8.1.2.6 Applicability of performance requirements for 4Rx capable UEs

For 4Rx capable UEs, the 2Rx supported RF bands and 4Rx supported RF bands are up to UE's declaration.

##### 8.1.2.6.1 Applicability rule and antenna connection for single carrier tests with 2Rx

For 4Rx capable UEs all single carrier tests specified in 8.2 to 8.8 with 2Rx are tested on any of the 2 Rx supported RF bands by connecting 2 out of the 4Rx with data source from system simulator, and the other 2 Rx are connected with zero input, depending on UE's declaration and AP configuration. Same requirements specified with 2Rx should be applied.

For 4Rx capable UEs without any 2Rx RF bands, all single carrier tests specified in 8.2 to 8.8 with 2Rx are tested on any of the 4Rx supported RF bands by duplicating the fading channel from each Tx antenna and add independent noise for each Rx antenna. Figure 8.1.2.6.1-1 shows an example of antenna connection for 4Rx UE in any one 4Rx supported RF band to perform a 2Rx performance test with antenna configuration as 2x2 without interference for information. The SNR requirements should be applied with 1.5 dB less than the number specified with 2Rx for test configuration with CRS-based TM and with 1.5 dB less than the number specified with 2Rx for test configuration with DMRS-based TM.

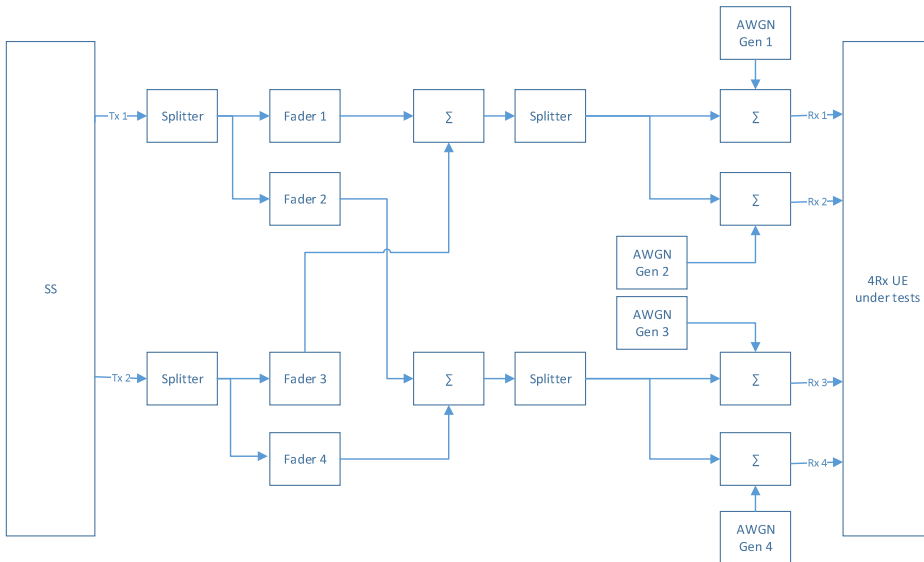

**Figure 8.1.2.6.1-1 Antenna connection example for 2Rx tests with antenna configuration as 2x2 without interference (informative)**

For 4Rx capable UEs without any 2Rx supported RF bands, for all single carrier tests listed in Table 8.1.2.6.1-0 specified from 8.2 to 8.8 with 2Rx can be skipped.

**Table 8.1.2.6.1-0: Requirement lists for 4Rx capable UEs**

Requirement lists
Enhanced downlink control channel performance requirements type A
Enhanced downlink control channel performance requirements type B
Enhanced performance requirements type B
Enhanced performance requirements type C
Requirements with demodulation subframe overlaps with aggressor cell ABS
Requirements with demodulation subframe overlaps with aggressor cell ABS and CRS assistance information are configured
Requirements with CRS assistance information configured

For 4Rx capable UEs, if corresponding tests listed from the 4Rx test lists from Table 8.1.2.6.1-1 are tested, the test coverage can be considered fulfilled without executing the corresponding tests listed from the 2Rx test lists from Table 8.1.2.6.1-1.

Table 8.1.2.6.1-1: Applicability rules for single carrier tests with 2Rx

4Rx test lists	2Rx test lists
8.10.1.1.1 Test 1	8.2.1.2.1 Test 1
8.10.1.1.2 Test 1	8.2.1.3.1 Test 1
8.10.1.1.3 Test 1	8.2.1.4.1B Test 1
8.10.1.1.4 Test 1	8.2.1.4.2 Test 1
8.10.1.1.4 Test 2	8.2.1.4.2 Test 3
8.10.1.1.5 Test 1	8.3.1.1A Test 1
8.10.1.1.5A Test 1	8.3.1.1 Test 2
8.10.1.1.5B Test 1	8.3.1.1H Test 1
8.10.1.1.6 Test 1	8.3.1.2 Test 1
8.10.1.1.14 Test 1	8.2.1.9.2 Test 1
8.10.1.2.1 Test 1	8.2.2.2.1 Test 1
8.10.1.2.2 Test 1	8.2.2.3.1 Test 1
8.10.1.2.3 Test 1	8.2.2.4.1B Test 1
8.10.1.2.4 Test 1	8.2.2.4.2 Test 1
8.10.1.2.4 Test 2	8.2.2.4.2 Test 3
8.10.1.2.5 Test 1	8.3.2.1B Test 1
8.10.1.2.5A Test 1	8.3.2.1A Test 2
8.10.1.2.5B Test 1	8.3.1.1I Test 1
8.10.1.2.6 Test 1	8.3.2.2 Test 2
8.10.1.2.14 Test 1	8.2.2.9.2 Test 1
8.10.2.1.1 Test 1	8.4.1.1 Test 1
8.10.2.1.2 Test 1	8.4.1.2.1 Test 1
8.10.2.1.3 Test 1	8.4.1.2.2 Test 1
8.10.2.2.1 Test 1	8.4.2.1 Test 1
8.10.2.2.2 Test 1	8.4.2.2.1 Test 1
8.10.2.2.3 Test 1	8.4.2.2.2 Test 1
8.10.3.1.1 Test 1	8.5.1.1 Test 1
8.10.3.1.2 Test 1	8.5.1.2.1 Test 1
8.10.3.1.3 Test 1	8.5.1.2.2 Test 1
8.10.3.2.1 Test 1	8.5.2.1 Test 1
8.10.3.2.2 Test 1	8.5.2.2.1 Test 1
8.10.3.2.3 Test 1	8.5.2.2.2 Test 1
8.10.4.1.1 Test 1	8.8.1.1 Test 1
8.10.4.1.1 Test 2	8.8.1.1 Test 2
8.10.4.1.2 Test 1	8.8.1.2 Test 1
8.10.4.1.2 Test 2	8.8.1.2 Test 2
8.10.4.2.1 Test 1	8.8.2.1 Test 1
8.10.4.2.1 Test 2	8.8.2.1 Test 2
8.10.4.2.2 Test 1	8.8.2.2 Test 1
8.10.4.2.2 Test 2	8.8.2.2 Test 2

#### 8.1.2.6.2 Applicability rule and antenna connection for CA and DC tests with 2Rx

All tests specified in 8.2 to 8.8 with 2Rx with CA, TDD-FDD CA and DC are tested with 4 Rx capable UEs.

Within the CA/DC configuration if any of the PCell and/or the SCells and/or PSCells is a 2Rx supported RF band, the antenna connection should follow the same method as defined in 8.1.2.6.1 for single carrier tests on any of the 2Rx supported RF bands, with same requirements specified with 2Rx applied. Within the CA configuration if any of the PCell and/or the SCells and/or PSCells is a 4Rx supported RF band, the antenna connection should follow the same as defined in 8.1.2.6.1 for single carrier tests on any of the 4 Rx supported RF bands, with the SNR requirements applied with 1.5 dB less than the number specified with 2Rx.

Same applicability rules defined in 8.1.2.3, 8.1.2.3A, and 8.1.2.3B for CA, TDD-FDD CA and DC applied for different CA and DC configurations and bandwidth combination sets should be applied for 4 Rx capable UEs.

#### 8.1.2.6.3 Applicability rule and antenna connection for single carrier tests with 4Rx

For 4Rx capable UEs all single carrier tests specified in 8.10 with 4Rx are tested on any of the 4Rx supported RF bands by connecting all 4Rx with data source from system simulator.

#### 8.1.2.6.4 Applicability rule for 256QAM tests

For 256QAM capable UE, if corresponding tests specified in 8.10.1.1.4 Test 2 and 8.10.1.2.4 Test 2 are tested, the test coverage can be considered fulfilled without executing the tests specified in 8.10.1.1.4 Test 1 and 8.10.1.2.4 Test 1. For a UE which does not have 256QAM capability, the test specified in 8.10.1.1.4 Test 1 and 8.10.1.2.4 Test 1 should be used.

#### 8.1.2.6.5 Applicability rule and antenna connection for CA and DC tests with 4Rx

All tests specified in 8.13 with FDD CA/DC, TDD CA/DC and TDD-FDD CA/DC are tested with 4 Rx capable UEs.

Within the CA/DC configuration if any of the PCell and/or the SCells/PSCell is a 2Rx supported RF band, 2 out of the 4Rx should be connected with data source from system simulator, and the other 2Rx are connected with zero input, depending on UE's declaration and AP configuration. Within the CA/DC configuration if any of the PCell and/or the SCells is a 4Rx supported RF band, all 4Rx should be connected with data source from system simulator.

For 4Rx capable UEs supporting different CA/DC configurations and bandwidth combination sets, the applicability and test rules are defined in Table 8.1.2.6.5-1 for FDD CA/DC, TDD CA/DC and TDD-FDD CA/DC. For simplicity, CA/DC configuration below refers to combination of CA/DC configuration and bandwidth combination set.

**Table 8.1.2.6.5-1: Applicability and test rules for CA/DC/TDD-FDD CA UE demodulation tests**

Tests	Step 1	Step 2	Step 3	Step 4
CA tests in Clause 8.13.1.1.1, 8.13.1.2.1	Select FDD CA configurations with the maximum number of CCs excluding the 2Rx only CA configuration among all supported FDD CA configurations with any CA capability	Select FDD CA configurations with maximum number of 4Rx CCs among all the selected FDD CA configurations from Step 1	Select any one of the FDD CA configuration with the largest aggregated CA bandwidth combination among all the selected FDD CA configurations from Step 2	NA
DC tests in Clause 8.13.1.1.2	Select FDD DC configurations with the maximum number of CCs excluding the 2Rx only DC configuration among all supported FDD DC configurations with any DC capability	Select FDD DC configurations with maximum number of 4Rx CCs among all the selected FDD DC configurations from Step 1	Select any one of the FDD DC configuration with the largest aggregated DC bandwidth combination among all the selected FDD DC configurations from Step 2	NA
CA tests in Clause 8.13.2.1.1, 8.13.2.2.1	Select TDD CA configurations with the maximum number of CCs excluding the 2Rx only CA configuration among all supported TDD CA configurations with any CA capability	Select TDD CA configurations with maximum number of 4Rx CCs among all the selected TDD CA configurations from Step 1	Select any one of the TDD CA configuration with the largest aggregated CA bandwidth combination among all the selected TDD CA configurations from Step 2	NA
DC tests in Clause 8.13.2.1.2	Select TDD DC configurations with the maximum number of CCs excluding the 2Rx only DC configuration among all supported TDD DC configurations with any DC capability	Select TDD DC configurations with maximum number of 4Rx CCs among all the selected TDD DC configurations from Step 1	Select any one of the TDD DC configuration with the largest aggregated DC bandwidth combination among all the selected TDD DC configurations from Step 2	NA
CA tests in Clause 8.13.3.1.1, 8.13.3.1.2, 8.13.3.2.1, 8.13.3.2.2	Select TDD-FDD CA configurations with the maximum number of CCs excluding the 2Rx only CA configuration among all supported TDD-FDD CA configurations with any CA capability	Select TDD-FDD CA configurations with maximum number of 4Rx CCs among all the selected TDD-FDD CA configurations from Step 1	Select any one of the TDD-FDD CA configuration with the largest aggregated CA bandwidth combination among all the selected TDD-FDD CA configurations from Step 2	NA
DC tests in Clause 8.13.3.5.1, 8.13.3.5.2	Select TDD-FDD DC configurations with the maximum number of CCs excluding the 2Rx only DC configuration among all supported TDD-FDD DC configurations with any DC capability	Select TDD-FDD DC configurations with maximum number of 4Rx CCs among all the selected TDD-FDD DC configurations from Step 1	Select any one of the TDD-FDD DC configuration with the largest aggregated DC bandwidth combination among all the selected TDD-FDD DC configurations from Step 2	NA



CA tests in Clause 8.13.1.3.1, 8.13.1.4.1, 8.13.1.1.3	Select FDD CA configurations with the maximum number of CCs excluding the 2Rx only CA configuration among all supported FDD CA configurations with any CA capability	Select FDD CA configurations with maximum number of 4Rx CCs among all the selected FDD CA configurations from Step 1	Select any one of the FDD CA configuration with the largest aggregated CA bandwidth combination among all the selected FDD CA configurations from Step 2	Select 2CCs with maximum number of 4Rx CCs with the largest aggregated CA bandwidth combination among the selected FDD CA configuration from Step 3
CA tests in Clause 8.13.2.3.1, 8.13.2.4.1, 8.13.2.1.3	Select TDD CA configurations with the maximum number of CCs excluding the 2Rx only CA configuration among all supported TDD CA configurations with any CA capability	Select TDD CA configurations with maximum number of 4Rx CCs among all the selected TDD CA configurations from Step 1	Select any one of the TDD CA configuration with the largest aggregated CA bandwidth combination among all the selected TDD CA configurations from Step 2	Select 2CCs with maximum number of 4Rx CCs with the largest aggregated CA bandwidth combination among the selected TDD CA configuration from Step 3
CA tests in Clause 8.13.3.3.1, 8.13.3.3.2, 8.13.3.4.1, 8.13.3.4.2, 8.13.3.6.1, 8.13.3.6.2	Select TDD-FDD CA configurations with the maximum number of CCs excluding the 2Rx only CA configuration among all supported TDD-FDD CA configurations with any CA capability	Select TDD-FDD CA configurations with maximum number of 4Rx CCs among all the selected TDD-FDD CA configurations from Step 1	Select any one of the TDD-FDD CA configuration with the largest aggregated CA bandwidth combination among all the selected TDD CA configurations from Step 2	Select 2CCs with maximum number of 4Rx CCs with the largest aggregated CA bandwidth combination among the selected TDD-FDD CA configuration from Step 3
CA tests in Clause 8.13.1.1.4	Select FDD CA configurations with the maximum number of CCs supporting 4 layers MIMO among all supported FDD CA configurations with any CA capability	Select any one of the FDD CA configuration with the largest aggregated CA bandwidth combinations on any 2CCs among all the CCs among all the selected FDD CA configuration from Step 1	NA	NA
CA tests in Clause 8.13.2.1.4	Select TDD CA configurations with the maximum number of CCs supporting 4 layers MIMO among all supported TDD CA configurations with any CA capability	Select any one of the TDD CA configuration with the largest aggregated CA bandwidth combinations on any 2CCs among all the CCs among all the selected TDD CA configuration from Step 1	NA	NA
CA tests in Clause 8.13.3.7.1, 8.13.3.7.2	Select TDD-FDD CA configurations with the maximum number of CCs supporting 4 layers MIMO among all supported TDD-FDD CA configurations with any CA capability	Select any one of the TDD-FDD CA configuration with the largest aggregated CA bandwidth combinations on any 2CCs among all the CCs among all the selected TDD-FDD CA configuration from Step 1	NA	NA
NOTE 1: The applicability and test rules are specified in this table, unless otherwise stated. NOTE 2: Number of the supported bandwidth combinations to be tested from each selected CA configuration is 1. NOTE 3: A single Uplink CC is configured for all CA tests and 2 Uplink CCs are configured for all DC tests.				

For 4Rx capable UEs, if corresponding tests listed from the 4Rx CA/DC test lists from Table 8.1.2.6.5-2 are tested, the test coverage can be considered fulfilled without executing the corresponding tests listed from the 2Rx CA/DC test lists from Table 8.1.2.6.5-2.

**Table 8.1.2.6.5-2: Test lists for applicability rules for CA/DC/TDD-FDD CA tests with 4Rx**

4Rx test lists	2Rx test lists
8.13.1.1.1 CA tests	8.2.1.4.3 CA tests
8.13.1.1.2 DC tests	8.2.1.4.3A DC tests
8.13.1.2.1 CA tests	8.2.1.1.1 CA tests
8.13.2.1.1 CA tests	8.2.2.4.3 CA tests
8.13.2.1.2 DC tests	8.2.2.4.3A DC tests
8.13.2.2.1 CA tests	8.2.2.1.1 CA tests
8.13.3.1.1 CA tests	8.2.3.3.1 CA tests
8.13.3.1.2 CA tests	8.2.3.3.2 CA tests
8.13.3.2.1 CA tests	8.2.3.1.1 CA tests
8.13.3.2.2 CA tests	8.2.3.1.2 CA tests
8.13.1.1.3 CA tests	8.2.1.4.2 test 3 and 8.10.1.1.4 test 2
8.13.1.1.4 CA tests	8.10.1.1.8 test 1
8.13.1.3.1 CA tests	8.2.1.4.1B test 1 and 8.10.1.1.3 test 1
8.13.1.4.1 CA tests	8.3.1.1A test 1 and 8.10.1.1.5 test 1
8.13.2.1.3 CA tests	8.2.2.4.2 test 3 and 8.10.1.2.4 test 2
8.13.2.1.4 CA tests	8.10.1.2.8 test 1
8.13.2.3.1 CA tests	8.2.2.4.1B test 1 and 8.10.1.2.3 test 1
8.13.2.4.1 CA tests	8.3.2.1B test 1 and 8.10.1.2.5 test 1

#### 8.1.2.6.6 Applicability rule for Type C with 4Rx

For Type C with 4Rx capable UEs, if the tests from the 4Rx test lists are tested from Table 8.1.2.6.6-1, the test coverage can be considered fulfilled without executing the corresponding test from 2Rx test lists from Table 8.1.2.6.6-1.

**Table 8.1.2.6.6-1: Applicability rules for Type C with 4Rx**

Test category	Type C with 2Rx test lists	Type C with 4Rx test lists
FDD Tests	8.2.1.3.1B	8.2.1.3.1B
	8.2.1.3.1C	8.2.1.3.1C
	8.2.1.4.2A	8.10.1.1.4A
	8.3.1.2A	8.10.1.1.6A
TDD Tests	8.2.2.3.1B	8.2.2.3.1B
	8.2.2.3.1C	8.2.2.3.1C
	8.2.2.4.2A	8.10.1.2.4A
	8.3.2.2A	8.10.1.2.6A

#### 8.1.2.6.7 Applicability rule for 1024QAM tests

For 1024QAM capable UE, if corresponding tests specified in 8.10.1.1.4 Test 3, 8.10.1.2.4 Test 3, 8.10.1.1.6B Test 1, and 8.10.1.2.6B Test 1 are tested, the test coverage can be considered fulfilled without executing the tests specified in 8.10.1.1.4 Test 1-2, 8.10.1.2.4 Test 1-2, 8.2.1.4.1A Test2, 8.2.2.4.1A Test 2, 8.3.1.1 Test 5, and 8.3.2.1A Test 5.

#### 8.1.2.7 Applicability of Enhanced Downlink Control Channel Performance Requirements

For UE which supports downlink control channel Type A or Type B interference mitigation capabilities the tests from Table 8.1.2.7-1 rows corresponding should be applied in accordance to the supported UE-EUTRA-Capability [7].

Table 8.1.2.7-1: Applicability rules for enhanced downlink control channel performance requirements

Test set	UE-EUTRA-Capability [7]	Test category		Test list	Applicability notes
1	cch-InterfMitigation-RefRecTypeA-r13 (Enhanced downlink control channel interference mitigation Type A receiver for 2 CRS antenna ports for UEs with 2 receiver antenna ports)	FDD	PDCCH/PCFICH	8.4.1.2.5 Test 1 8.4.1.2.6 Test 1	
			PHICH	8.5.1.2.5 Test 1 8.5.1.2.6 Test 1	
			EPDCCH	8.8.4.1 Test 1 8.8.6.1 Test 1	
		TDD	PDCCH/PCFICH	8.4.2.2.5 Test 1 8.4.2.2.6 Test 1	
			PHICH	8.5.2.2.5 Test 1 8.5.2.2.6 Test 1	
			EPDCCH	8.8.4.2 Test 1 8.8.5.1 Test 1	
2	cch-InterfMitigation-RefRecTypeA-r13 (Enhanced downlink control channel interference mitigation Type A receiver for 4 CRS antenna ports for UEs with 2 receiver antenna ports)	FDD	PDCCH/PCFICH	8.4.1.2.9 Test 1	UE may skip the tests 8.4.1.2.6 and 8.4.2.2.6 defined for test set 1
		TDD	PDCCH/PCFICH	8.4.2.2.9 Test 1	
3	cch-InterfMitigation-RefRecTypeB-r13	FDD	PDCCH/PCFICH	8.4.1.2.5 Test 1 8.4.1.2.7 Test 1 8.4.1.2.8 Test 1	UE may skip the tests defined for test set 1
			PHICH	8.5.1.2.5 Test 1 8.5.1.2.7 Test 1 8.5.1.2.8 Test 1	
			EPDCCH	8.8.4.1 Test 1 8.8.6.1 Test 1	
		TDD	PDCCH/PCFICH	8.4.2.2.7 Test 1 8.4.2.2.8 Test 1	
			PHICH	8.5.2.2.7 Test 1 8.5.2.2.8 Test 1	
			EPDCCH	8.8.4.2 Test 1 8.8.5.1 Test 1	
4	MMSE-IRC DL Control Channel interference mitigation receiver for UEs with 4 receiver antenna ports [TS 36.306 Section 6.6.5]	FDD	PDCCH/PCFICH	8.10.2.1.4 Test 1	
		TDD	PDCCH/PCFICH	8.10.2.2.4 Test 1	
5	[Enhanced downlink control channel interference mitigation Type A receiver for 2 CRS antenna ports for UEs with 1 receiver antenna ports and Category 1bis]	FDD	PDCCH/PCFICH	8.9.4.1.1 Test 1	
		TDD	PDCCH/PCFICH	[8.9.4.2.1 Test 1]	
6	[Enhanced downlink control channel interference mitigation Type A receiver for 4 CRS antenna ports for UEs with 1 receiver antenna ports and Category 1bis]	FDD	PDCCH/PCFICH	8.9.4.1.2 Test 1	UE may skip the tests defined for test set 5
		TDD	PDCCH/PCFICH	[8.9.4.2.2 Test 1]	
7	[Enhanced downlink control channel interference mitigation Type A receiver for 2 CRS antenna ports for UEs with 1 receiver antenna ports and Category M2]	FDD	MPDCCH	8.11.2.1.3 Test 1 8.11.2.1.4 Test 1	
		TDD	MPDCCH	8.11.2.2.3 Test 1 8.11.2.2.4 Test 1	

### 8.1.2.8 Applicability of performance requirements for CDM-multiplexed DM RS with interfering simultaneous transmission (FRC) with multiple CSI-RS configurations

For a UE which supports DMRS enhancement (dmrs-Enhancements-r13 UE-EUTRA-Capability [7]), if corresponding tests specified in 8.3.1.1H Test 1 and 8.3.2.1I Test 1 are tested, the test coverage can be considered fulfilled without executing the tests specified in 8.3.1.1 Test 2 and 8.3.2.1A Test 2. For a UE which does not have DMRS enhancement capability, the test specified in 8.3.1.1 Test 2 and 8.3.2.1A Test 2 should be used.

### 8.1.2.8A Applicability of performance requirements for UE supporting coverage enhancement

The applicability and test rules are defined for the tests for UE supporting coverage enhancement with narrowband transmission in Table 8.1.2.8A-1 and 8.1.2.8A-2.

**Table 8.1.2.8A-1: Applicability rules for PDSCH requirements (FDD)**

UE-EUTRA-Capability	ue-Category or UE-CategoryDL	
	M1, Cat-0, 1bis	>=1 (Note 1)
ce-ModeA-r13	8.11.1.1.1.1 Test 1 8.11.1.1.2.1 Test 1 8.11.1.1.3.1 Test 2	8.11.1.1.2.1 Test 2 8.11.1.1.2.1 Test 3
ce-ModeB-r13	8.11.1.1.1.1 Test 1 8.11.1.1.2.1 Test 1 8.11.1.1.3.1 Test 1	8.11.1.1.2.1 Test 2 8.11.1.1.2.1 Test 3 8.11.1.1.3.1 Test 3 8.11.1.1.3.1 Test 4
Note 1: Which test case applies to the UE depends on the supported receiver antenna number.		

**Table 8.1.2.8A-2: Applicability rules for PDSCH requirements (TDD)**

UE-EUTRA-Capability	ue-Category or UE-CategoryDL	
	M1, Cat-0, 1bis	>=1 (Note 1)
ce-ModeA-r13	8.11.1.2.1.1 Test 1 8.11.1.2.2.1 Test 1 8.11.1.2.3.1 Test 2	8.11.1.2.2.1 Test 2 8.11.1.2.2.1 Test 3
ce-ModeB-r13	8.11.1.2.1.1 Test 1 8.11.1.2.2.1 Test 1 8.11.1.2.3.1 Test 1	8.11.1.2.2.1 Test 2 8.11.1.2.2.1 Test 3 8.11.1.2.3.1 Test 3 8.11.1.2.3.1 Test 4
Note 1: Which test case applies to the UE depends on the supported receiver antenna number.		

The applicability and test rules are defined for the tests for UE supporting coverage enhancement with wideband transmission in Table 8.1.2.8A-3 and 8.1.2.8A-4.

**Table 8.1.2.8A-3: Applicability rules for PDSCH requirements (FDD)**

UE-EUTRA-Capability	ue-Category or UE-CategoryDL		
	M2, Cat-0, 1bis	≥1 (Note 1)	
ce-PDSCH-PUSCH-MaxBandwidth-r14	5MHz	5MHz	20MHz
ce-ModeA-r13	8.11.1.1.1.1 Test 1 8.11.1.1.2.1 Test 1 8.11.1.1.3.2 Test 1	8.11.1.1.2.1 Test 2 8.11.1.1.2.1 Test 3	8.11.1.1.2.1 Test 2 8.11.1.1.2.1 Test 3 8.11.1.1.3.2 Test 3 8.11.1.1.3.2 Test 4
ce-ModeB-r13	8.11.1.1.1.1 Test 1 8.11.1.1.2.1 Test 1 8.11.1.1.3.2 Test 2	8.11.1.1.2.1 Test 2 8.11.1.1.2.1 Test 3 8.11.1.1.3.1 Test 3 8.11.1.1.3.1 Test 4	8.11.1.1.2.1 Test 2 8.11.1.1.2.1 Test 3 8.11.1.1.3.1 Test 3 8.11.1.1.3.1 Test 4

Note 1: Which test case applies to the UE depends on the supported receiver antenna number.

**Table 8.1.2.8A-4: Applicability rules for PDSCH requirements (TDD)**

UE-EUTRA-Capability	ue-Category or UE-CategoryDL		
	M2, Cat-0, 1bis	≥1 (Note 1)	
ce-PDSCH-PUSCH-MaxBandwidth-r14	5MHz	5MHz	20MHz
ce-ModeA-r13	8.11.1.2.1.1 Test 1 8.11.1.2.2.1 Test 1 8.11.1.2.3.2 Test 1	8.11.1.2.2.1 Test 2 8.11.1.2.2.1 Test 3	8.11.1.2.2.1 Test 2 8.11.1.2.2.1 Test 3 8.11.1.2.3.2 Test 3 8.11.1.2.3.2 Test 4
ce-ModeB-r13	8.11.1.2.1.1 Test 1 8.11.1.2.2.1 Test 1 8.11.1.2.3.2 Test 2	8.11.1.2.2.1 Test 2 8.11.1.2.2.1 Test 3 8.11.1.2.3.1 Test 3 8.11.1.2.3.1 Test 4	8.11.1.2.2.1 Test 2 8.11.1.2.2.1 Test 3 8.11.1.2.3.1 Test 3 8.11.1.2.3.1 Test 4

Note 1: Which test case applies to the UE depends on the supported receiver antenna number.

The applicability and test rules are defined for the tests for UE supporting coverage enhancement in Tables 8.1.2.8A-5 and 8.1.2.8A-6.

**Table 8.1.2.8A-5: Applicability rules for PDSCH requirements (FDD)**

UE-EUTRA-Capability	ue-Category or UE-CategoryDL	
	M1	M2
ce-ModeA-r13	8.11.1.1.3.1 Test 2a 8.11.1.1.3.1 Test 5 8.11.1.1.3.1 Test 6	8.11.1.1.3.1 Test 5 8.11.1.1.3.1 Test 6
ce-ModeB-r13		8.11.1.1.3.2 Test 2a

**Table 8.1.2.8A-6: Applicability rules for PDSCH requirements (TDD)**

UE-EUTRA-Capability	ue-Category or UE-CategoryDL	
	M1	M2
ce-ModeA-r13	8.11.1.2.3.1 Test 2a 8.11.1.2.3.1 Test 5 8.11.1.2.3.1 Test 6	8.11.1.2.3.1 Test 5 8.11.1.2.3.1 Test 6
ce-ModeB-r13		8.11.1.2.3.2 Test 2a

### 8.1.2.9 Applicability of SDR requirements for CA and LAA

For UE supporting both CA and LAA, UE selects the corresponding SDR tests between CA and LAA as per the following applicability rules:

- Select one CA bandwidth combination among all supported CA configurations with bandwidth combination and MIMO layer on each CC following the equation that leads to largest equivalent aggregated bandwidth among all CA bandwidth combinations supported by UE. Equivalent aggregated bandwidth is defined as

$$B_{agg} = \sum_{i=0}^{N-1} R_i B_i$$

where  $N$  is number of CCs,  $R_i \in \{2,4\}$  and  $B_i \in \{5,10,15,20\}$  is MIMO layer and bandwidth of CC  $i$ .

- When there are LAA and non-LAA CA configurations with the same largest aggregated bandwidth, select non-LAA CA configuration.

#### 8.1.2.10 Applicability of performance requirements for Multi-user Superposed Transmission

For a UE which does not support DMRS enhancement table (dmrs-Enhancements-r13 UE-EUTRA-Capability [7]), if corresponding tests specified in 8.3.1.1I Test 1, 8.3.2.1J Test 1 are tested, the test coverage can be considered fulfilled without executing other tests specified in 8.3.1.1I and 8.3.2.1J.

For a UE which supports DMRS enhancement table (dmrs-Enhancements-r13 UE-EUTRA-Capability [7]) and enhanced performance Type D in TM8/9 or TM10 with assistance information for up to 1 interfering layer, if corresponding tests specified in 8.3.1.1I Test 2, 8.3.2.1J Test 2 are tested, the test coverage can be considered fulfilled without executing other tests specified in 8.3.1.1I and 8.3.2.1J.

For a UE which supports DMRS enhancement table (dmrs-Enhancements-r13 UE-EUTRA-Capability [7]) and enhanced performance Type D in TM8/9 or TM10 with assistance information for up to 3 interfering layer, if corresponding tests specified in 8.3.1.1I Test 3, 8.3.2.1J Test 3 are tested, the test coverage can be considered fulfilled without executing other tests specified in 8.3.1.1I and 8.3.2.1J.

#### 8.1.2.11 Applicability CRS interference mitigation receivers performance requirements

For UE which supports CRS interference mitigation capabilities the tests from Table 8.1.2.11-1 should be applied in accordance to the support UE capabilities (UE-EUTRA-Capability [7]).

**Table 8.1.2.11-1: Applicability rules for CRS interference mitigation performance requirements**

Test set	UE-EUTRA-Capability [7]	Test list		Notes
		FDD	TDD	
1	crs-InterfMitigationTM1toTM9-r13 (CRS-IM with 2 CRS antenna ports for PDSCH for UEs with 2 receiver antenna ports)	8.2.1.4.1E Test 1 8.3.1.1G Test 1	8.2.2.4.1E Test 1 8.3.2.1H Test 1	
2	crs-InterfMitigationTM10-r13	8.3.1.3.4 Test 1 8.3.1.3.5 Test 1	8.3.2.3.4 Test 1 8.3.2.3.5 Test 1	
3	crs-InterfMitigationTM1toTM9-r13 (CRS-IM with 4 CRS antenna ports for PDSCH for UEs with 2 receiver antenna ports)	8.2.1.4.1F Test 1 8.3.1.1G Test 1	8.2.2.4.1F Test 1 8.3.2.1H Test 1	UE may skip the tests defined for test set 1
4	crs-InterfMitigationTM1toTM9-r13 (CRS-IM with 2 CRS antenna ports for PDSCH for UEs with 4 receiver antenna ports)	8.10.1.1.10 Test 1 8.10.1.1.12 Test 1	8.10.1.2.10 Test 1 8.10.1.2.12 Test 1	UE may skip the tests defined for test set 1
5	crs-InterfMitigationTM1toTM9-r13 (CRS-IM with 4 CRS antenna ports for PDSCH for UEs with 4 receiver antenna ports)	8.10.1.1.11 Test 1 8.10.1.1.12 Test 1	8.10.1.2.11 Test 1 8.10.1.2.12 Test 1	UE may skip the tests defined for test sets 1,3 and 4
6	[CRS-IM with 2 CRS antenna ports for PDSCH for UEs with 1 receiver antenna port and Category 1bis]	8.9.1.1.3.2 Test 1	8.9.1.2.3.2 Test 1	
7	[CRS-IM with 4 CRS antenna ports for PDSCH for UEs with 1 receiver antenna port and Category 1bis]	8.9.1.1.2.3 Test 1	8.9.1.2.2.3 Test 1	UE may skip the tests defined for test set 6
8	[CRS-IM with 2 CRS antenna ports for PDSCH for UEs with 1 receiver antenna port and Category M2]	8.11.1.1.1.2 Test 1	8.11.1.1.2.2 Test 1	
9	[CRS-IM with 4 CRS antenna ports for PDSCH for UEs with 1 receiver antenna port and Category M2]	8.11.1.1.1.3 Test 1	8.11.1.1.2.3 Test 1	UE may skip the tests defined for test set 8

### 8.1.2.12 Applicability of performance requirements for 8Rx capable UEs

For 8Rx capable UEs, the 2Rx supported RF bands, 4Rx supported RF bands and 8Rx supported RF bands are up to UE's declaration.

For any demodulation tests and CSI tests conducted in the 8Rx supported RF band, four receive antenna ports that UE may use for control channel demodulation are clarified via UE declaration. When testing an N-Rx ( $N = 2,4$ ) demodulation or CSI test on the 8Rx supported band, the fading duplication and antenna mapping should guarantee that the four receive antennas UE declares for the control channel demodulation collectively receives at least  $4/N$  duplicated version of the fading channel seen at each receive antenna of the N-Rx test, i.e., the connection diagrams in Figure 8.1.2.12.1-1 to Figure 8.1.2.12.1-4 are valid under the condition that Rx1, Rx3, Rx5 and Rx7 are the four receive antennas declared by UE for the control channel demodulation.

#### 8.1.2.12.1 Applicability rule and antenna connection for single carrier PDSCH tests

##### 8.1.2.12.1.1 Applicability rule and antenna connection for single carrier PDSCH tests with 2Rx and 4Rx

For 8Rx capable UEs, all single carrier tests specified in 8.2 to 8.8 with 2Rx are tested on any of the 2Rx supported RF bands by connecting 2 out of the 8Rx with data source from system simulator, and the other 6 Rx are connected with zero input, depending on UE's declaration and AP configuration. Same requirements specified with 2Rx should be applied.

For 8Rx capable UEs, all single carrier test cases specified in 8.10 with 4Rx are tested on any of the 4Rx supported RF bands by connecting 4 out of 8 Rx with data source from system simulator, and the other 4 Rx are connected with zero input, depending on UE's declaration and AP configuration. Same requirements specified with 4Rx should be applied.

For 8Rx capable UEs without support of any 4Rx RF bands, all single carrier tests specified in 8.10 with 4Rx are tested on any of the 8Rx supported RF bands by duplicating the fading channel from each Tx antenna and add independent noise for each Rx antenna. The SNR requirements should be applied with 1.5 dB less than the number specified for 4Rx tests.

For 8Rx capable UEs without support of any 2Rx and 4Rx RF bands, all single carrier tests specified in 8.2 to 8.8 with 2Rx are tested on any of the 8Rx supported RF bands by duplicating the fading channel from each Tx antenna and add independent noise for each Rx antenna. The SNR requirements should be applied with 3 dB less than the number specified for 2Rx tests.

For 8Rx capable UEs without support of any 2Rx RF bands but with support of 4Rx RF bands, all single carrier tests specified in 8.2 to 8.8 with 2Rx are tested on any of the 4Rx supported RF bands by duplicating the fading channel from each Tx antenna and add independent noise for each Rx antenna. 4 out of 8 Rx are connected with data source from system simulator, and the other 4 Rx are connected with zero input, depending on UE's declaration and AP configuration. SNR requirements should be applied with 1.5 dB less than the number specified for 2Rx tests.

Figure 8.1.2.12.1-1 ~ Figure 8.1.2.12.1-4 show examples of antenna connection for 8Rx capable UE in any one 8Rx supported RF band to perform a 2Rx or 4Rx performance test with antenna configuration as 2x2 or 4x2 for 2Rx tests and 2x4 or 4x4 for 4Rx tests without interference for information.

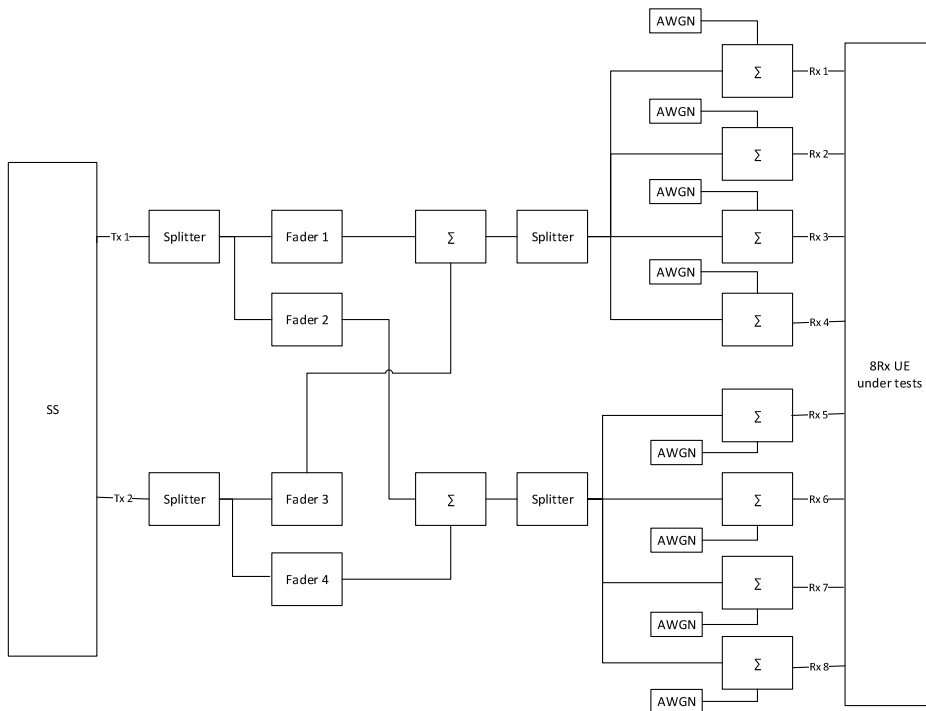

Figure 8.1.2.12.1-1: Antenna connection example for 2Rx tests with antenna configuration as 2x2 without interference (informative)



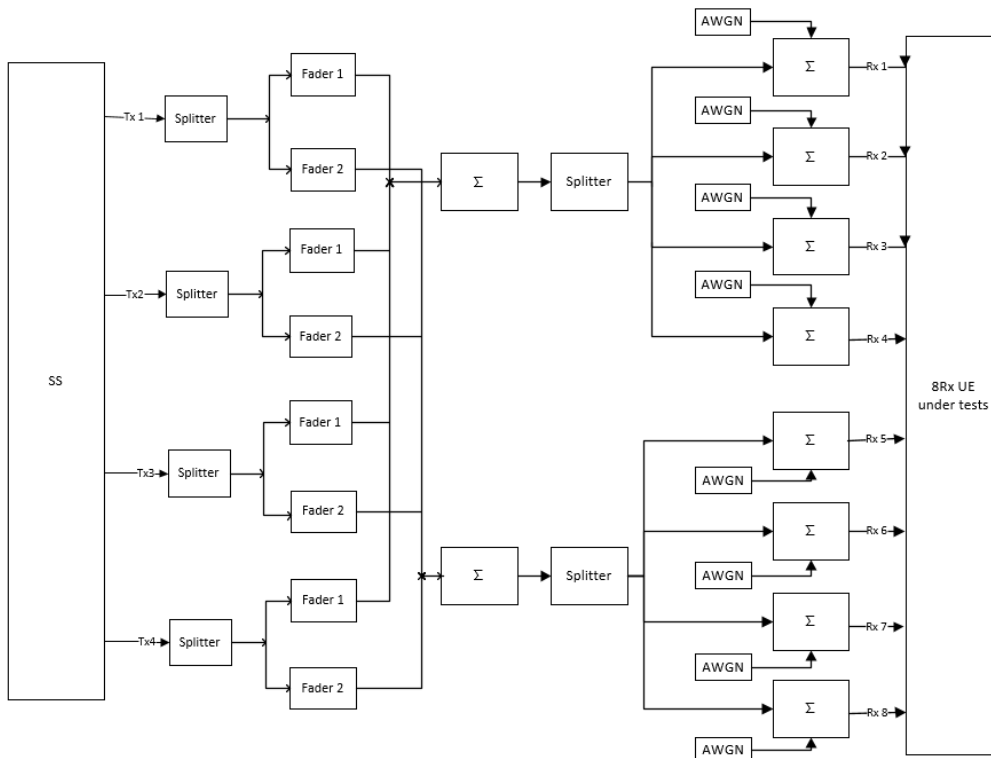

Figure 8.1.2.12.1-2: Antenna connection example for 2Rx tests with antenna configuration as 4x2 without interference (informative)

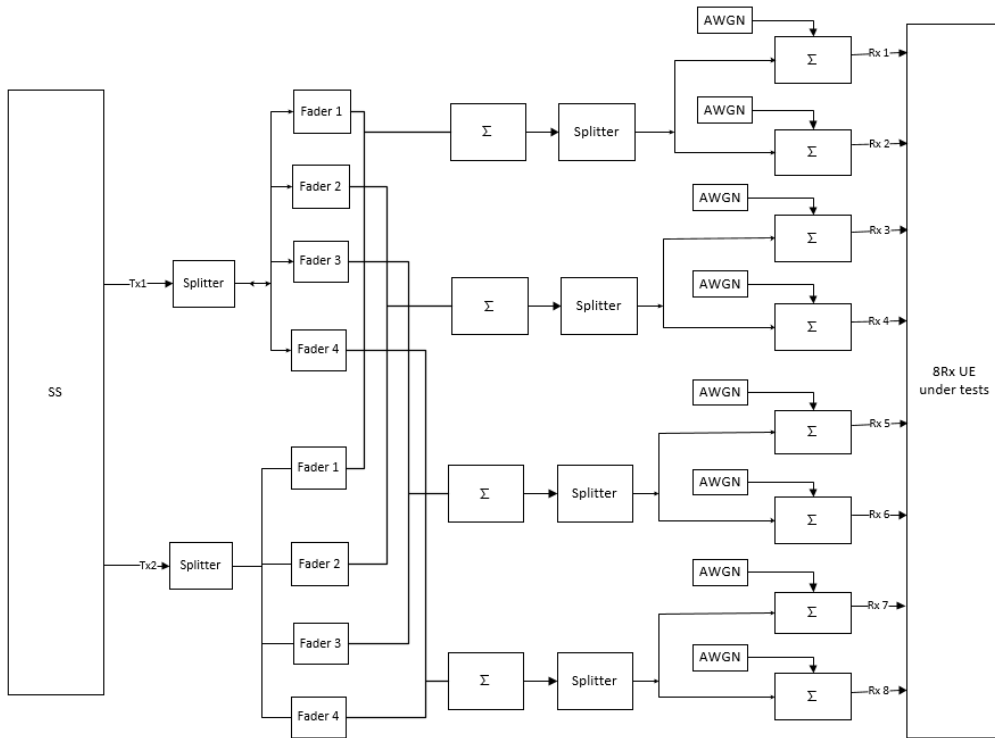
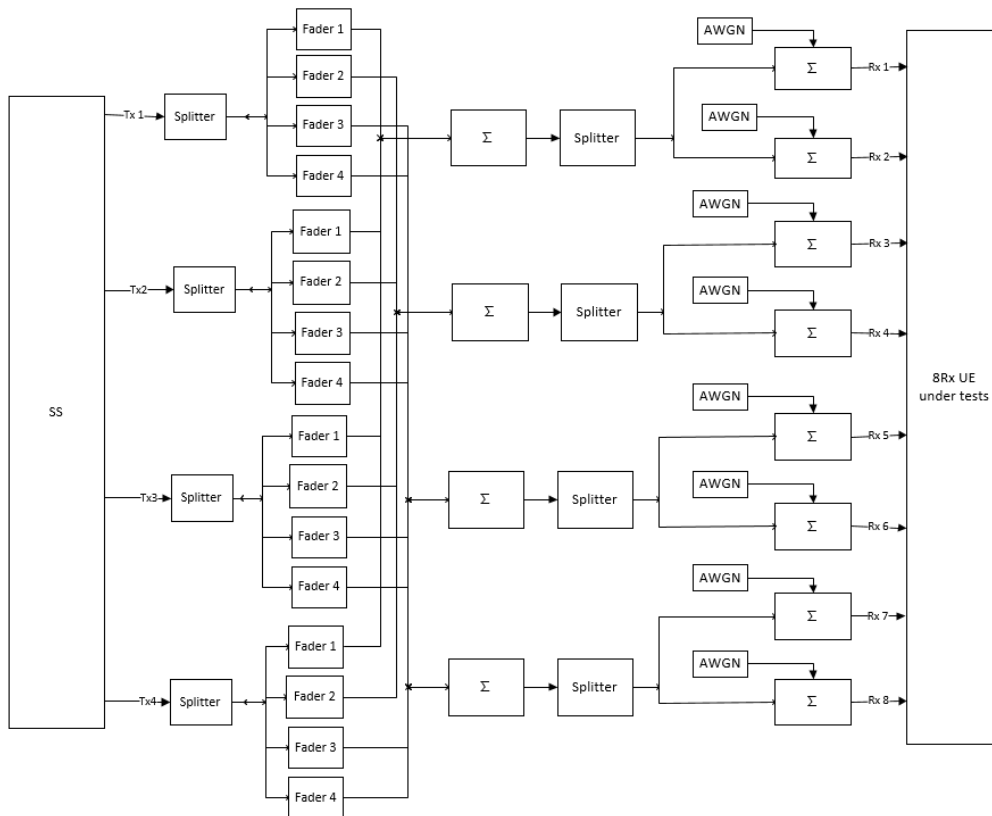

Figure 8.1.2.12.1-3: Antenna connection example for 4Rx tests with antenna configuration as 2x4 without interference (informative)



**Figure 8.1.2.12.1-4: Antenna connection example for 4Rx tests with antenna configuration as 4x4 without interference (informative)**

For 8Rx capable UEs without any 2Rx supported RF bands, for all single carrier tests listed in Table 8.1.2.12.1-1 specified from 8.2 to 8.8 with 2Rx can be skipped.

**Table 8.1.2.12.1-1: Requirement lists with 2Rx not applicable to 8Rx capable UEs**

Requirement lists
Enhanced downlink control channel performance requirements type A
Enhanced downlink control channel performance requirements type B
Enhanced performance requirements type A
Enhanced performance requirements type B
Enhanced performance requirements type C
Requirements with demodulation subframe overlaps with aggressor cell ABS
Requirements with demodulation subframe overlaps with aggressor cell ABS and CRS assistance information are configured
Requirements with CRS assistance information configured

For 8Rx capable UEs without any 4Rx supported RF bands, for all single carrier tests listed in Table 8.1.2.12.1-2 specified in 8.10 with 4Rx can be skipped.

**Table 8.1.2.12.1-2: Requirement lists with 4Rx not applicable to 8Rx capable UEs**

Requirement lists
Enhanced downlink control channel performance requirements type A
Enhanced performance requirements type A
Enhanced performance requirements type C
Requirements with CRS assistance information configured

For 8Rx capable UEs, if corresponding tests listed from the 8Rx test lists from Table 8.1.2.12.1-3 are tested, the test coverage can be considered fulfilled without executing the corresponding tests listed from both the 4Rx test lists and the 2Rx test lists from Table 8.1.2.12.1-3.

For 8Rx capable UEs, if corresponding tests listed from the 4Rx test lists from Table 8.1.2.12.1-3 are tested, the test coverage can be considered fulfilled without executing the corresponding tests listed from the 2Rx test lists from Table 8.1.2.12.1-3.

**Table 8.1.2.12.1-3: Applicability rules for single carrier tests with 2Rx**

8Rx test lists	4Rx test lists	2Rx test lists
	8.10.1.1.1 Test 1	8.2.1.2.1 Test 1
	8.10.1.1.2 Test 1	8.2.1.3.1 Test 1
	8.10.1.1.3 Test 1	8.2.1.4.1B Test 1
	8.10.1.1.4 Test 1	8.2.1.4.2 Test 1
	8.10.1.1.4 Test 2	8.2.1.4.2 Test 3
	8.10.1.1.5 Test 1	8.3.1.1A Test 1
	8.10.1.1.5A Test 1	8.3.1.1 Test 2
	8.10.1.1.5B Test 1	8.3.1.1H Test 1
	8.10.1.1.6 Test 1	8.3.1.2 Test 1
8.14.1.2.1 Test 1	8.10.1.2.1 Test 1	8.2.2.2.1 Test 1
8.14.1.2.2 Test 1	8.10.1.2.2 Test 1	8.2.2.3.1 Test 1
	8.10.1.2.3 Test 1	8.2.2.4.1B Test 1
	8.10.1.2.4 Test 1	8.2.2.4.2 Test 1
	8.10.1.2.4 Test 2	8.2.2.4.2 Test 3
	8.10.1.2.5 Test 1	8.3.2.1B Test 1
	8.10.1.2.5A Test 1	8.3.2.1A Test 2
	8.10.1.2.5B Test 1	8.3.1.1I Test 1
	8.10.1.2.6 Test 1	8.3.2.2 Test 2
	8.10.2.1.1 Test 1	8.4.1.1 Test 1
	8.10.2.1.2 Test 1	8.4.1.2.1 Test 1
	8.10.2.1.3 Test 1	8.4.1.2.2 Test 1
	8.10.2.2.1 Test 1	8.4.2.1 Test 1
	8.10.2.2.2 Test 1	8.4.2.2.1 Test 1
	8.10.2.2.3 Test 1	8.4.2.2.2 Test 1
	8.10.3.1.1 Test 1	8.5.1.1 Test 1
	8.10.3.1.2 Test 1	8.5.1.2.1 Test 1
	8.10.3.1.3 Test 1	8.5.1.2.2 Test 1
	8.10.3.2.1 Test 1	8.5.2.1 Test 1
	8.10.3.2.2 Test 1	8.5.2.2.1 Test 1
	8.10.3.2.3 Test 1	8.5.2.2.2 Test 1
	8.10.4.1.1 Test 1	8.8.1.1 Test 1
	8.10.4.1.1 Test 2	8.8.1.1 Test 2
	8.10.4.1.2 Test 1	8.8.1.2 Test 1
	8.10.4.1.2 Test 2	8.8.1.2 Test 2
	8.10.4.2.1 Test 1	8.8.2.1 Test 1
	8.10.4.2.1 Test 2	8.8.2.1 Test 2
	8.10.4.2.2 Test 1	8.8.2.2 Test 1
	8.10.4.2.2 Test 2	8.8.2.2 Test 2

#### 8.1.2.12.1.2 Applicability rule and antenna connection for single carrier PDSCH tests with 8Rx

For 8Rx capable UEs all single carrier tests specified in 8.14 with 8Rx are tested on any of the 8Rx supported RF bands by connecting all 8Rx with data source from system simulator.

### 8.1.2.12.2 Applicability rule and antenna connection for control channel tests

#### 8.1.2.12.2.1 Applicability rule and antenna connection for control channel tests with 2Rx

For 8Rx capable UEs, all single carrier tests specified in 8.2 to 8.8 for control channel with 2Rx are tested on any of the 2Rx supported RF bands by connecting 2 out of the 8Rx with data source from system simulator, and the other 6 Rx are connected with zero input, depending on UE's declaration and AP configuration. Same requirements specified with 2Rx should be applied.

For 8Rx capable UEs without any 2Rx supported RF bands and with 4Rx supported RF bands, all single carrier tests specified in 8.2 to 8.8 for control channel with 2Rx are tested on any of the 4Rx supported RF bands by duplicating the fading channel from each Tx antenna and add independent noise for each Rx antenna. The SNR requirements should be applied with 1.5 dB less than the number specified for 2Rx tests.

For 8Rx capable UEs without any 2Rx and without 4Rx supported RF bands, all single carrier tests specified in 8.2 to 8.8 for control channel with 2Rx are tested on any of the 8Rx supported RF bands by duplicating the fading channel from each Tx antenna and add independent noise for each Rx antenna, as illustrated in Figure 8.1.2.12.1-1 and Figure 8.1.2.12.1-2. The SNR requirements should be applied with 1.5 dB less than the number specified for 2Rx tests.

#### 8.1.2.12.2.2 Applicability rule and antenna connection for control channel tests with 4Rx

For 8Rx capable UEs, all single carrier tests specified in 8.10 for control channel with 4Rx are tested on any of the 4Rx supported RF bands by connecting 4 out of the 8Rx with data source from system simulator, and the other 4 Rx are connected with zero input, depending on UE's declaration and AP configuration. Same requirements specified with 4Rx should be applied.

For 8Rx capable UEs without any 4Rx supported RF bands, all single carrier tests specified in 8.10 for control channel with 4Rx are tested on any of the 8Rx supported RF bands by duplicating the fading channel from each Tx antenna and add independent noise for each Rx antenna, as illustrated in Figure 8.1.2.12.1-3 and Figure 8.1.2.12.1-4. Same requirements specified with 4Rx should be applied.

### 8.1.2.12.3 Applicability rule and antenna connection for CA and DC tests

#### 8.1.2.12.3.1 Applicability rule and antenna connection for CA and DC tests with 2Rx

All tests specified in 8.2 to 8.8 with 2Rx with CA, TDD-FDD CA and DC are tested with 8 Rx capable UEs.

Within the CA/DC configuration if any of the PCell and/or the SCells and/or PSCells is a 2Rx supported RF band, the antenna connection should follow the same method as defined in 8.1.2.12.1 and 8.1.2.12.2 for single carrier tests on any of the 2Rx supported RF bands, with the same requirements specified with 2Rx applied.

Within the CA configuration if any of the PCell and/or the SCells and/or PSCells is a 4Rx supported RF band, the antenna connection should follow the same as illustrated in Figure 8.1.2.12.1-1 and Figure 8.1.2.12.1-2 for single carrier tests on any of the 4 Rx supported RF bands, with the SNR requirements applied with 1.5dB less than the number specified with 2Rx.

Within the CA configuration if any of the PCell and/or the SCells and/or PSCells is an 8Rx supported RF band, the antenna connection should follow the same as illustrated in Figure 8.1.2.12.1-1 and Figure 8.1.2.12.1-2 for single carrier tests on any of the 8Rx supported RF bands, with the SNR requirements applied with 3.0dB less than the number specified with 2Rx for PDSCH tests and 1.5dB less than the number specified with 2Rx for control channel tests.

Same applicability rules defined in 8.1.2.3, 8.1.2.3A, and 8.1.2.3B for CA, TDD-FDD CA and DC applied for different CA and DC configurations and bandwidth combination sets should be applied for 8 Rx capable UEs.

#### 8.1.2.12.3.2 Applicability rule and antenna connection for CA tests with 4Rx

All tests specified in 8.13 with 4Rx with FDD CA/DC, TDD CA/DC and TDD-FDD CA/DC are tested with 8 Rx capable UEs.

Within the CA/DC configuration if any of the PCell and/or the SCells and/or PSCells is a 4Rx supported RF band, the antenna connection should follow the same method as defined in 8.1.2.12.1 and 8.1.2.12.2 for single carrier tests on any of the 4Rx supported RF bands, with the same requirements specified with 4Rx applied.

Within the CA configuration if any of the PCell and/or the SCells and/or PSCells is an 8Rx supported RF band, the antenna connection should follow the same as illustrated in Figure 8.1.2.12.1-3 and Figure 8.1.2.12.1-4 for single carrier PDSCH tests on any of the 8Rx supported RF bands, with the SNR requirements applied with 1.5dB less than the number specified with 4Rx for PDSCH tests, and with the same SNR requirements as specified with 4Rx applied for control channel test.

Same applicability rules defined in 8.1.2.6.5 for CA, TDD-FDD CA and DC applied for different CA and DC configurations and bandwidth combination sets should be applied for 8 Rx capable UEs.

### 8.1.2.12.3.3 Applicability rule and antenna connection for CA tests with 8Rx

All tests specified in 8.14.2 with 8Rx with TDD CA are tested with 8 Rx capable UEs.

Within the CA configuration if any of the PCell and/or the SCells and/or PSCells is an 8Rx supported RF band, the antenna connection should follow the same method as defined in 8.1.2.12.1 for single carrier PDSCH tests on any of the 8Rx supported RF bands, with the same requirements specified with 8Rx applied.

For 8Rx capable UEs supporting different CA configurations and bandwidth combination sets, the applicability and test rules are defined in Table 8.1.2.12.3-1 for TDD CA. For simplicity, CA configuration below refers to combination of CA configuration and bandwidth combination set.

**Table 8.1.2.12.3-1: Applicability and test rules for CA UE demodulation tests**

Tests	Step 1	Step 2	Step 3	Step 4
CA tests in Clause 8.14.2.2.1	Select TDD CA configurations with the maximum number of CCs supporting 8 layers MIMO among all supported TDD CA configurations with any CA capability	Select any one of the TDD CA configuration with the largest aggregated CA bandwidth combinations on any 2CCs among all the CCs among all the selected TDD CA configuration from Step 1	NA	NA
NOTE 1: The applicability and test rules are specified in this table, unless otherwise stated. NOTE 2: Number of the supported bandwidth combinations to be tested from each selected CA configuration is 1. NOTE 3: A single Uplink CC is configured for all CA tests.				

### 8.1.3 UE category and UE DL category

UE category and UE DL category refer to *ue-Category* and *ue-CategoryDL* define in 4.1 and 4.1A from [12]. A UE that belongs to either a UE category or a UE DL category indicated in UE performance requirements in subclause 8, 9, 10 shall fulfil the corresponding requirements.

A UE indicating DL category 13 may indicate category 9 or 10 and shall thereby fulfil all requirements in subclause 8, 9, 10 that are indicated for either cat 9 or DL Cat 13 UEs. For SDR tests in section 8.7 both cat 9 and cat 13 test shall be used for this UE while for the other test only Cat 13 tests needs to be done.

## 8.2 Demodulation of PDSCH (Cell-Specific Reference Symbols)

### 8.2.1 FDD (Fixed Reference Channel)

The parameters specified in Table 8.2.1-1 are valid for all FDD tests unless otherwise stated.

**Table 8.2.1-1: Common Test Parameters (FDD)**

Parameter	Unit	Value
Inter-TTI Distance		1
Number of HARQ processes per component carrier	Processes	8
Maximum number of HARQ transmission		4
Redundancy version coding sequence		{0,1,2,3} for QPSK and 16QAM {0,0,1,2} for 64QAM, 256QAM and 1024QAM
Number of OFDM symbols for PDCCH per component carrier	OFDM symbols	4 for 1.4 MHz bandwidth, 3 for 3 MHz and 5 MHz bandwidths, 2 for 10 MHz, 15 MHz and 20 MHz bandwidths unless otherwise stated
Cyclic Prefix		Normal
Cell ID		0
Cross carrier scheduling		Not configured

### 8.2.1.1 Single-antenna port performance

The single-antenna performance in a given multi-path fading environments is determined by the SNR for which a certain relative information bit throughput of the reference measurement channels in Annex A.3.3 is achieved. The purpose of these tests is to verify the single-antenna performance with different channel models and MCS. The QPSK and 64QAM cases are also used to verify the performance for all bandwidths specified in Table 5.6.1-1.

#### 8.2.1.1.1 Minimum Requirement

For single carrier, the requirements are specified in Table 8.2.1.1.1-2, with the addition of the parameters in Table 8.2.1.1.1-1 and the downlink physical channel setup according to Annex C.3.2.

For CA with 2 DL CCs, the requirements are specified in Table 8.2.1.1.1-4, with the addition of the parameters in Table 8.2.1.1.1-3 and the downlink physical channel setup according to Annex C.3.2.

For CA with 3 DL CCs, the requirements are specified in Table 8.2.1.1.1-6, based on single carrier requirement specified in Table 8.2.1.1.1-5, with the addition of the parameters in Table 8.2.1.1.1-3 and the downlink physical channel setup according to Annex C.3.2.

For CA with 4 DL CCs, the requirements are specified in Table 8.2.1.1.1-7, based on single carrier requirement specified in Table 8.2.1.1.1-5, with the addition of the parameters in Table 8.2.1.1.1-3 and the downlink physical channel setup according to Annex C.3.2.

For CA with 5 DL CCs, the requirements are specified in Table 8.2.1.1.1-8, based on single carrier requirement specified in Table 8.2.1.1.1-5, with the addition of the parameters in Table 8.2.1.1.1-3 and the downlink physical channel setup according to Annex C.3.2.

For CA with 6 DL CCs, the requirements are specified in Table 8.2.1.1.1-9, based on single carrier requirement specified in Table 8.2.1.1.1-5, with the addition of the parameters in Table 8.2.1.1.1-3 and the downlink physical channel setup according to Annex C.3.2.

For CA with 7 DL CCs, the requirements are specified in Table 8.2.1.1.1-10, based on single carrier requirement specified in Table 8.2.1.1.1-5, with the addition of the parameters in Table 8.2.1.1.1-3 and the downlink physical channel setup according to Annex C.3.2.

The test coverage for different number of component carriers is defined in 8.1.2.4.

Table 8.2.1.1.1-1: Test Parameters

Parameter	Unit	Test 1- 5	Test 6- 8	Test 9- 15	Test 16- 18	Test 19
Downlink power allocation	$\rho_A$	dB	0	0	0	0
	$\rho_B$	dB	0 (NOTE 1)	0 (NOTE 1)	0 (NOTE 1)	0 (NOTE 1)
	$\sigma$	dB	0	0	0	0
$N_{oc}$ at antenna port	dBm/15kHz	-98	-98	-98	-98	-98
Symbols for unused PRBs		OCNG (NOTE 2)	OCNG (NOTE 2)	OCNG (NOTE 2)	OCNG (NOTE 2)	OCNG (NOTE 2)
Modulation		QPSK	16QAM	64QAM	16QAM	QPSK
PDSCH transmission mode		1	1	1	1	1
NOTE 1: $P_B = 0$ .						
NOTE 2: These physical resource blocks are assigned to an arbitrary number of virtual UEs with one PDSCH per virtual UE; the data transmitted over the OCNG PDSCHs shall be uncorrelated pseudo random data, which is QPSK modulated.						
NOTE 3: Void.						
NOTE 4: Void.						



Table 8.2.1.1.1-2: Minimum performance (FRC)

Test num.	Bandwidth	Reference channel	OCNG pattern	Propagation condition	Correlation matrix and antenna config.	Reference value		UE category
						Fraction of maximum throughput (%)	SNR (dB)	
1	10 MHz	R.2 FDD	OP.1 FDD	EVA5	1x2 Low	70	-1.0	≥1
2	10 MHz	R.2 FDD	OP.1 FDD	ETU70	1x2 Low	70	-0.4	≥1
3	10 MHz	R.2 FDD	OP.1 FDD	ETU300	1x2 Low	70	0.0	≥1
4	10 MHz	R.2 FDD	OP.1 FDD	HST	1x2	70	-2.4	≥1
5	1.4 MHz	R.4 FDD	OP.1 FDD	EVA5	1x2 Low	70	0.0	≥1
6	10 MHz	R.3 FDD	OP.1 FDD	EVA5	1x2 Low	70	6.7	≥2
	5 MHz	R.3-1 FDD	OP.1 FDD	EVA5	1x2 Low	70	6.7	1
	5 MHz (NOTE 4)	R.3-1 FDD	OP.1 FDD	EVA5	1x2 Low	70	6.7	≥2
7	10 MHz	R.3 FDD	OP.1 FDD	ETU70	1x2 Low	30	1.4	≥2
	5 MHz	R.3-1 FDD	OP.1 FDD	ETU70	1x2 Low	30	1.4	1
	5 MHz (NOTE 4)	R.3-1 FDD	OP.1 FDD	ETU70	1x2 Low	30	1.4	≥2
8	10 MHz	R.3 FDD	OP.1 FDD	ETU300	1x2 High	70	9.4	≥2
	5 MHz	R.3-1 FDD	OP.1 FDD	ETU300	1x2 High	70	9.4	1
	5 MHz (NOTE 4)	R.3-1 FDD	OP.1 FDD	ETU300	1x2 High	70	9.4	≥2
9	3 MHz	R.5 FDD	OP.1 FDD	EVA5	1x2 Low	70	17.6	≥1
10	5 MHz	R.6 FDD	OP.1 FDD	EVA5	1x2 Low	70	17.4	≥2
	5 MHz	R.6-1 FDD	OP.1 FDD	EVA5	1x2 Low	70	17.5	1
11	10 MHz	R.7 FDD	OP.1 FDD	EVA5	1x2 Low	70	17.7	≥2
	10 MHz	R.7-1 FDD	OP.1 FDD	EVA5	1x2 Low	70	16.7	1
12	10 MHz	R.7 FDD	OP.1 FDD	ETU70	1x2 Low	70	19.0	≥2
	10 MHz	R.7-1 FDD	OP.1 FDD	ETU70	1x2 Low	70	18.1	1
13	10 MHz	R.7 FDD	OP.1 FDD	EVA5	1x2 High	70	19.1	≥2
	10 MHz	R.7-1 FDD	OP.1 FDD	EVA5	1x2 High	70	17.8	1
14	15 MHz	R.8 FDD	OP.1 FDD	EVA5	1x2 Low	70	17.7	≥2
	15 MHz	R.8-1 FDD	OP.1 FDD	EVA5	1x2 Low	70	16.8	1
15	20 MHz	R.9 FDD	OP.1 FDD	EVA5	1x2 Low	70	17.6	≥3
	20 MHz	R.9-2 FDD	OP.1 FDD	EVA5	1x2 Low	70	17.3	2
	20 MHz	R.9-1 FDD	OP.1 FDD	EVA5	1x2 Low	70	16.7	1
16	3 MHz	R.0 FDD	OP.1 FDD	ETU70	1x2 Low	30	1.9	≥1
17	10 MHz	R.1 FDD	OP.1 FDD	ETU70	1x2 Low	30	1.9	≥1
18	20 MHz	R.1 FDD	OP.1 FDD	ETU70	1x2 Low	30	1.9	≥1
19	10 MHz	R.41 FDD	OP.1 FDD	EVA5	1x2 Low	70	-5.4	≥1
NOTE 1: Void.								
NOTE 2: Void.								
NOTE 3: Void.								
NOTE 4: Test case applicability is defined in 8.1.2.1.								

Table 8.2.1.1.1-3: Test Parameters for CA

Parameter	Unit	Value	
Downlink power allocation	$\rho_A$	dB	0
	$\rho_B$	dB	0 (NOTE 1)
	$\sigma$	dB	0
$N_{oc}$ at antenna port	dBm/15kHz	-98	
Symbols for unused PRBs		OCNG (NOTE 2)	
Modulation		QPSK	
PDSCH transmission mode		1	
NOTE 1: $P_B = 0$ .			
NOTE 2: These physical resource blocks are assigned to an arbitrary number of virtual UEs with one PDSCH per virtual UE; the data transmitted over the OCNG PDSCHs shall be uncorrelated pseudo random data, which is QPSK modulated.			
NOTE 3: PUCCH format 1b with channel selection is used to feedback ACK/NACK for Tests in Table 8.2.1.1.1-4, PUCCH format 3 is used to feedback ACK/NACK for Tests in Table 8.2.1.1.1-6.			
NOTE 4: The same PDSCH transmission mode is applied to each component carrier.			

Table 8.2.1.1.1-4: Minimum performance (FRC) for CA with 2DL CCs

Test num.	Bandwidth	Reference channel	OCNG pattern	Propagation condition	Correlation matrix and antenna config.	Reference value		UE category
						Fraction of maximum throughput (%)	SNR (dB)	
1	2x10 MHz	R.2 FDD	OP.1 FDD (NOTE 1)	EVA5	1x2 Low	70	-1.1	$\geq 3$ (NOTE 2)
2	2x20 MHz	R.42 FDD	OP.1 FDD (NOTE 1)	EVA5	1x2 Low	70	-1.3	$\geq 5$
3	2x5 MHz	R.42-2 FDD	OP.1 FDD	EVA5	1x2 Low	70	-1.0	$\geq 2$
			OP.1 FDD			70	-1.0	
4	10MHz +5MHz	R.2 FDD for 10MHz CC	OP.1 FDD	EVA5	1x2 Low	70	-1.7	$\geq 3$
		R.42-2 FDD for 5MHz CC	OP.1 FDD			70	-1.0	
5	15MHz +5MHz	R.42-3 FDD for 15MHz CC	OP.1 FDD	EVA5	1x2 Low	70	-1.6	$\geq 3$
		R.42-2 FDD for 5MHz CC	OP.1 FDD			70	-1.0	
NOTE 1: The OCNG pattern applies for each CC.								
NOTE 2: 30usec timing difference between two CCs is applied in inter-band CA case.								
NOTE 3: The applicability of requirements for different CA configurations and bandwidth combination sets is defined in 8.1.2.3.								

Table 8.2.1.1.1-5: Single carrier performance for multiple CA configurations

Band-width	Reference channel	OCNG pattern	Propagation condition	Correlation matrix and antenna config.	Reference value	
					Fraction of maximum throughput (%)	SNR (dB)
1.4MHz	R.4 FDD	OP.1 FDD	EVA5	1x2 Low	70	-1.3
3MHz	R.42-1 FDD	OP.1 FDD	EVA5	1x2 Low	70	-1.1
5MHz	R.42-2 FDD	OP.1 FDD	EVA5	1x2 Low	70	-1.0
10MHz	R.2 FDD	OP.1 FDD	EVA5	1x2 Low	70	-1.7
15MHz	R.42-3 FDD	OP.1 FDD	EVA5	1x2 Low	70	-1.6
20MHz	R.42 FDD	OP.1 FDD	EVA5	1x2 Low	70	-1.7

Table 8.2.1.1.1-6: Minimum performance (FRC) based on single carrier performance for CA with 3DL CCs

Test num.	CA Band-width combination	Requirement	UE category
1	3x20MHz	As specified in Table 8.2.1.1.1-5 per CC	≥5
2	20MHz+20MHz+15MHz	As specified in Table 8.2.1.1.1-5 per CC	≥5
3	20MHz+20MHz+10MHz	As specified in Table 8.2.1.1.1-5 per CC	≥5
4	20MHz+15MHz+15MHz	As specified in Table 8.2.1.1.1-5 per CC	≥5
5	20MHz+15MHz+10MHz	As specified in Table 8.2.1.1.1-5 per CC	≥5
6	20MHz+10MHz+10MHz	As specified in Table 8.2.1.1.1-5 per CC	≥5
7	15MHz+15MHz+10MHz	As specified in Table 8.2.1.1.1-5 per CC	≥5
8	20MHz+10MHz+5MHz	As specified in Table 8.2.1.1.1-5 per CC	≥5
9	20MHz+15MHz+5MHz	As specified in Table 8.2.1.1.1-5 per CC	≥5
10	10MHz+10MHz+5MHz	As specified in Table 8.2.1.1.1-5 per CC	≥5
11	5MHz+5MHz+20MHz	As specified in Table 8.2.1.1.1-5 per CC	≥5
12	3x10MHz	As specified in Table 8.2.1.1.1-5 per CC	≥5
13	5MHz+5MHz+10MHz	As specified in Table 8.2.1.1.1-5 per CC	≥5
NOTE 1: The applicability of requirements for different CA configurations and bandwidth combination sets is defined in 8.1.2.3			
NOTE 2: 30usec timing difference between PCell and any SCell, which is not within the same band or sub-block as PCell, is applied in inter-band CA case, where PCell can be assigned on any CC.			

**Table 8.2.1.1.1-7: Minimum performance (FRC) based on single carrier performance for CA with 4DL CCs**

Test num.	CA Band-width combination	Requirement	UE category
1	4x20MHz	As specified in Table 8.2.1.1.1-5 per CC	≥8
2	10MHz+20MHz+20MHz+20MHz	As specified in Table 8.2.1.1.1-5 per CC	≥8
3	10MHz+10MHz+20MHz+20MHz	As specified in Table 8.2.1.1.1-5 per CC	≥8
4	5MHz+10MHz+20MHz+20MHz	As specified in Table 8.2.1.1.1-5 per CC	≥8
5	5MHz+10MHz+10MHz+20MHz	As specified in Table 8.2.1.1.1-5 per CC	≥8
6	15+3x20MHz	As specified in Table 8.2.1.1.1-5 per CC	≥8
7	2x15+2x20MHz	As specified in Table 8.2.1.1.1-5 per CC	≥8
8	10+15+2x20MHz	As specified in Table 8.2.1.1.1-5 per CC	≥8
9	3x10+20MHz	As specified in Table 8.2.1.1.1-5 per CC	≥8
10	2x5+2x20MHz	As specified in Table 8.2.1.1.1-5 per CC	≥8
11	2x5+10+20MHz	As specified in Table 8.2.1.1.1-5 per CC	≥8
12	4x10MHz	As specified in Table 8.2.1.1.1-5 per CC	≥8
NOTE 1: The applicability of requirements for different CA configurations and bandwidth combination sets is defined in 8.1.2.3			
NOTE 2: 30usec timing difference between PCell and any SCell, which is not within the same band or sub-block as PCell, is applied in inter-band CA case, where PCell can be assigned on any CC.			

**Table 8.2.1.1.1-8: Minimum performance (FRC) based on single carrier performance for CA with 5DL CCs**

Test num.	CA Band-width combination	Requirement	UE category
1	5x20MHz	As specified in Table 8.2.1.1.1-5 per CC	8, ≥11
2	15MHz+4x20MHz	As specified in Table 8.2.1.1.1-5 per CC	8, ≥11
3	10MHz+4x20MHz	As specified in Table 8.2.1.1.1-5 per CC	8, ≥11
4	2x10MHz+3x20MHz	As specified in Table 8.2.1.1.1-5 per CC	8, ≥11
5	5MHz+10MHz+3x20MHz	As specified in Table 8.2.1.1.1-5 per CC	8, ≥11
6	3x10MHz+2x20MHz	As specified in Table 8.2.1.1.1-5 per CC	8, ≥11
7	4x10MHz+20MHz	As specified in Table 8.2.1.1.1-5 per CC	8, ≥11
NOTE 1: The applicability of requirements for different CA configurations and bandwidth combination sets is defined in 8.1.2.3			
NOTE 2: 30usec timing difference between PCell and any SCell, which is not within the same band or sub-block as PCell, is applied in inter-band CA case, where PCell can be assigned on any CC.			

**Table 8.2.1.1.1-9: Minimum performance (FRC) based on single carrier performance for CA with 6DL CCs**

Test num.	CA Band-width combination	Requirement	UE category
1	6x20MHz	As specified in Table 8.2.1.1.1-5 per CC	8, ≥11
NOTE 1: The applicability of requirements for different CA configurations and bandwidth combination sets is defined in 8.1.2.3			
NOTE 2: 30usec timing difference between PCell and any SCell, which is not within the same band or sub-block as PCell, is applied in inter-band CA case, where PCell can be assigned on any CC.			

**Table 8.2.1.1.1-10: Minimum performance (FRC) based on single carrier performance for CA with 7DL CCs**

Test num.	CA Band-width combination	Requirement	UE category
1	7x20MHz	As specified in Table 8.2.1.1.1-5 per CC	8, ≥11
NOTE 1: The applicability of requirements for different CA configurations and bandwidth combination sets is defined in 8.1.2.3			
NOTE 2: 30usec timing difference between PCell and any SCell, which is not within the same band or sub-block as PCell, is applied in inter-band CA case, where PCell can be assigned on any CC.			

8.2.1.1.2 Void

8.2.1.1.3 Void

8.2.1.1.4 Minimum Requirement 1 PRB allocation in presence of MBSFN

The requirements are specified in Table 8.2.1.1.4-2, with the addition of the parameters in Table 8.2.1.1.4-1 and the downlink physical channel setup according to Annex C.3.2. The purpose of these tests is to verify the single-antenna performance with a single PRB allocated at the lower band edge in presence of MBSFN.

**Table 8.2.1.1.4-1: Test Parameters for Testing 1 PRB allocation**

Parameter	Unit	Test 1	
Downlink power allocation	$\rho_A$	dB	0
	$\rho_B$	dB	0 (NOTE 1)
	$\sigma$	dB	0
$N_{oc}$ at antenna port	dBm/15kHz	-98	
Symbols for MBSFN portion of MBSFN subframes (NOTE 2)		OCNG (NOTE 3)	
PDSCH transmission mode		1	
NOTE 1: $P_B = 0$			
NOTE 2: The MBSFN portion of an MBSFN subframe comprises the whole MBSFN subframe except the first two symbols in the first slot.			
NOTE 3: The MBSFN portion of the MBSFN subframes shall contain QPSK modulated data. Cell-specific reference signals are not inserted in the MBSFN portion of the MBSFN subframes, QPSK modulated MBSFN data is used instead.			

**Table 8.2.1.1.4-2: Minimum performance 1PRB (FRC)**

Test number	Bandwidth	Reference Channel	OCNG Pattern	Propagation Condition	Correlation Matrix and Antenna Configuration	Reference value		UE Category
						Fraction of Maximum Throughput (%)	SNR (dB)	
1	10 MHz	R.29 FDD	OP.3 FDD	ETU70	1x2 Low	30	2.0	$\geq 1$

8.2.1.1.4A Minimum Requirement 1 PRB allocation in presence of FeMBMS Unicast-mixed Cell under CA

The requirements are specified in Table 8.2.1.1.4A-2, with the addition of the parameters in Table 8.2.1.1.4A-1 and the downlink physical channel setup according to Annex C.3.2. The purpose of these tests is to verify the single-antenna performance with a single PRB allocated at the lower band edge in presence of FeMBMS Unicast-mixed Cell under CA.

**Table 8.2.1.1.4A-1: Test Parameters for Testing 1 PRB allocation under CA**

Parameter	Unit	Test 1	
Downlink power allocation	$\rho_A$	dB	0
	$\rho_B$	dB	0 (NOTE 1)
	$\sigma$	dB	0
$N_{oc}$ at antenna port	dBm/15kHz	-98	
Symbols for MBSFN portion of MBSFN subframes (NOTE 2)		OCNG (NOTE 3)	
PDSCH transmission mode in PCell and SCell		1	
Numerology in the MBSFN subframe in SCell		1.25kHz	
NOTE 1: $P_B = 0$			
NOTE 2: The MBSFN portion of an MBSFN subframe comprises the whole MBSFN subframe.			
NOTE 3: The MBSFN portion of the MBSFN subframes shall contain QPSK modulated data. Cell-specific reference signals are not inserted in the MBSFN portion of the MBSFN subframes, QPSK modulated MBSFN data is used instead.			

**Table 8.2.1.1.4A-2: Minimum performance 1PRB (FRC)**

Test number	Cell	Bandwidth	Reference Channel	OCNG Pattern	Propagation Condition	Correlation Matrix and Antenna Configuration	Reference value		UE Category
							Fraction of Maximum Throughput (%)	SNR (dB)	
1	PCell	10 MHz	NA	OP.3 FDD	AWGN	1x2 Low	NA	NA	$\geq 1$
	SCell	10MHz	R.29-1 FDD	OP.3A FDD	ETU70	1x2 Low	30	[2.9]	$\geq 1$
Note 1: If Test 1 in Table 8.2.1.1.4A-2 is tested, the test coverage can be considered fulfilled without executing Test 1 in Table 8.2.1.1.4-2.									

## 8.2.1.2 Transmit diversity performance

### 8.2.1.2.1 Minimum Requirement 2 Tx Antenna Port

The requirements are specified in Table 8.2.1.2.1-2, with the addition of the parameters in Table 8.2.1.2.1-1 and the downlink physical channel setup according to Annex C.3.2. The purpose is to verify the performance of transmit diversity (SFBC) with 2 transmitter antennas.

**Table 8.2.1.2.1-1: Test Parameters for Transmit diversity Performance (FRC)**

Parameter	Unit	Test 1-2	
Downlink power allocation	$\rho_A$	dB	-3
	$\rho_B$	dB	-3 (NOTE 1)
	$\sigma$	dB	0
$N_{oc}$ at antenna port	dBm/15kHz	-98	
PDSCH transmission mode		2	
NOTE 1: $P_B = 1$ .			

**Table 8.2.1.2.1-2: Minimum performance Transmit Diversity (FRC)**

Test number	Bandwidth	Reference Channel	OCNG Pattern	Propagation Condition	Correlation Matrix and Antenna Configuration	Reference value		UE Category
						Fraction of Maximum Throughput (%)	SNR (dB)	
1	10 MHz	R.11 FDD	OP.1 FDD	EVA5	2x2 Medium	70	6.8	$\geq 2$
	5 MHz	R.11-2 FDD	OP.1 FDD	EVA5	2x2 Medium	70	5.9	1
	5 MHz (NOTE 1)	R.11-2 FDD	OP.1 FDD	EVA5	2x2 Medium	70	5.9	$\geq 2$
2	10 MHz	R.10 FDD	OP.1 FDD	HST	2x2	70	-2.3	$\geq 1$

NOTE 1: Test case applicability is defined in 8.1.2.1.

**8.2.1.2.2 Minimum Requirement 4 Tx Antenna Port**

The requirements are specified in Table 8.2.1.2.2-2, with the addition of the parameters in Table 8.2.1.2.2-1 and the downlink physical channel setup according Annex C.3.2. The purpose is to verify the performance of transmit diversity (SFBC-FSTD) with 4 transmitter antennas.

**Table 8.2.1.2.2-1: Test Parameters for Transmit diversity Performance (FRC)**

Parameter	Unit	Test 1-2	
Downlink power allocation	$\rho_A$	dB	-3
	$\rho_B$	dB	-3 (NOTE 1)
	$\sigma$	dB	0
$N_{oc}$ at antenna port	dBm/15kHz	-98	
PDSCH transmission mode		2	
NOTE 1: $P_B = 1$ .			

**Table 8.2.1.2.2-2: Minimum performance Transmit Diversity (FRC)**

Test number	Bandwidth	Reference Channel	OCNG Pattern	Propagation Condition	Correlation Matrix and Antenna Configuration	Reference value		UE Category
						Fraction of Maximum Throughput (%)	SNR (dB)	
1	1.4 MHz	R.12 FDD	OP.1 FDD	EPA5	4x2 Medium	70	0.6	$\geq 1$
2	10 MHz	R.13 FDD	OP.1 FDD	ETU70	4x2 Low	70	-0.9	$\geq 1$

**8.2.1.2.3 Minimum Requirement 2 Tx Antenna Port (demodulation subframe overlaps with aggressor cell ABS)**

The requirements are specified in Table 8.2.1.2.3-2, with the addition of parameters in Table 8.2.1.2.3-1 and the downlink physical channel setup according to Annex C.3.2 and Annex C.3.3. The purpose is to verify the performance of transmit diversity (SFBC) with 2 transmit antennas if the PDSCH transmission in the serving cell takes place in subframes that overlap with ABS [9] of the aggressor cell. In Table 8.2.1.2.3-1, Cell 1 is the serving cell, and Cell 2 is the aggressor cell. The downlink physical channel setup for Cell 1 is according to Annex C.3.2 and for Cell 2 is according to Annex C.3.3, respectively.

**Table 8.2.1.2.3-1: Test Parameters for Transmit diversity Performance (FRC)**

Parameter		Unit	Cell 1	Cell 2
Downlink power allocation	$\rho_A$	dB	-3	-3
	$\rho_B$	dB	-3 (NOTE 1)	-3
	$\sigma$	dB	0	N/A
$N_{oc}$ at antenna port	$N_{oc1}$	dBm/15kHz	-102 (NOTE 2)	N/A
	$N_{oc2}$	dBm/15kHz	-98 (NOTE 3)	N/A
	$N_{oc3}$	dBm/15kHz	-94.8 (NOTE 4)	N/A
$E_s/N_{oc2}$		dB	Reference Value in Table 8.2.1.2.3- 2	6
BW <sub>Channel</sub>		MHz	10	10
Subframe Configuration			Non-MBSFN	Non-MBSFN
Time Offset between Cells		$\mu$ s	2.5 (synchronous cells)	
Cell Id			0	1
ABS pattern (NOTE 5)			N/A	11000100 11000000 11000000 11000000 11000000
RLM/RRM Measurement Subframe Pattern (NOTE 6)			10000000 10000000 10000000 10000000 10000000	N/A
CSI Subframe Sets (NOTE7)	C <sub>CSI,0</sub>		11000100 11000000 11000000 11000000 11000000	N/A
	C <sub>CSI,1</sub>		00111011 00111111 00111111 00111111 00111111	N/A
Number of control OFDM symbols			2	2
PDSCH transmission mode			2	N/A
Cyclic prefix			Normal	Normal

NOTE 1:  $P_B = 1$ .

NOTE 2: This noise is applied in OFDM symbols #1, #2, #3, #5, #6, #8, #9, #10, #12, #13 of a subframe overlapping with the aggressor ABS.

NOTE 3: This noise is applied in OFDM symbols #0, #4, #7, #11 of a subframe overlapping with the aggressor ABS.

NOTE 4: This noise is applied in all OFDM symbols of a subframe overlapping with aggressor non-ABS

NOTE 5: ABS pattern as defined in [9].

NOTE 6: Time-domain measurement resource restriction pattern for PCell measurements as defined in [7]

NOTE 7: As configured according to the time-domain measurement resource restriction pattern for CSI measurements defined in [7].

NOTE 8: Cell 1 is the serving cell. Cell 2 is the aggressor cell. The number of the CRS ports in Cell1 and Cell2 is the same.

NOTE 9: SIB-1 will not be transmitted in Cell2 in this test.



Table 8.2.1.2.3-2: Minimum Performance Transmit Diversity (FRC)

Test Number	Reference Channel	OCNG Pattern		Propagation Conditions (NOTE 1)		Correlation Matrix and Antenna Configuration	Reference Value		UE Category
		Cell 1	Cell 2	Cell 1	Cell 2		Fraction of Maximum Throughput (%) NOTE 5	SNR (dB) (Note 2)	
1	R.11-4 FDD (NOTE 4)	OP.1 FDD	OP.1 FDD	EVA5	EVA 5	2x2 Medium	70	3.4	≥2

NOTE 1: The propagation conditions for Cell 1 and Cell2 are statistically independent.

NOTE 2: SNR corresponds to  $E_s/N_{oc2}$  of cell 1.

NOTE 3: The correlation matrix and antenna configuration apply for Cell 1 and Cell 2.

NOTE 4: Cell 1 Reference channel is modified: PDSCH other than SIB1/paging and its associated PDCCH/PCFICH are transmitted in the serving cell subframe when the subframe is overlapped with the ABS subframe of aggressor cell and the subframe is available in the definition of the reference channel.

NOTE 5: The maximum Throughput is calculated from the total Payload in 9 subframes, averaged over 40ms.

### 8.2.1.2.3A Minimum Requirement 2 Tx Antenna Ports (demodulation subframe overlaps with aggressor cell ABS and CRS assistance information are configured)

The requirements are specified in Table 8.2.1.2.3A-2, with the addition of parameters in Table 8.2.1.2.3A-1. The purpose is to verify the performance of transmit diversity (SFBC) with 2 transmit antennas if the PDSCH transmission in the serving cell takes place in subframes that overlap with ABS [9] of the aggressor cells with CRS assistance information. In Table 8.2.1.2.3A-1, Cell 1 is the serving cell, and Cell 2 and Cell 3 are the aggressor cells. The downlink physical channel setup for Cell 1 is according to Annex C.3.2 and for Cell 2 and Cell 3 is according to Annex C.3.3, respectively. The CRS assistance information [7] includes Cell 2 and Cell 3.

Table 8.2.1.2.3A-1: Test Parameters for Transmit diversity Performance (FRC)

Parameter	Unit	Cell 1	Cell 2	Cell 3	
Downlink power allocation	$\rho_A$	dB	-3	-3	-3
	$\rho_B$	dB	-3 (NOTE 1)	-3 (NOTE 1)	-3 (NOTE 1)
	$\sigma$	dB	0	N/A	N/A
$N_{oc}$ at antenna port	$N_{oc1}$	dBm/15kHz	-98 (NOTE 2)	N/A	N/A
	$N_{oc2}$	dBm/15kHz	-98 (NOTE 3)	N/A	N/A
	$N_{oc3}$	dBm/15kHz	-93 (NOTE 4)	N/A	N/A
$\tilde{E}_s / N_{oc2}$	dB	Reference Value in Table 8.2.1.2.3 A-2	12	10	
$BW_{Channel}$	MHz	10	10	10	
Subframe Configuration		Non-MBSFN	Non-MBSFN	Non-MBSFN	
Time Offset between Cells	$\mu s$	N/A	3	-1	
Frequency shift between Cells	Hz	N/A	300	-100	
Cell Id		0	126	1	
ABS pattern (NOTE 5)		N/A	11000000 11000000 11000000 11000000 11000000	11000000 11000000 11000000 11000000 11000000	
RLM/RRM Measurement Subframe Pattern (NOTE 6)		10000000 10000000 10000000 10000000 10000000	N/A	N/A	
CSI Subframe Sets (NOTE 7)	$C_{CSI,0}$		11000000 11000000 11000000 11000000 11000000	N/A	N/A
	$C_{CSI,1}$		00111111 00111111 00111111 00111111 00111111	N/A	N/A
Number of control OFDM symbols		2	NOTE 8	NOTE 8	
PDSCH transmission mode		2	NOTE 9	NOTE 9	
Cyclic prefix		Normal	Normal	Normal	
NOTE 1: $P_B = 1$ .					
NOTE 2: This noise is applied in OFDM symbols #1, #2, #3, #5, #6, #8, #9, #10, #12, #13 of a subframe overlapping with the aggressor ABS.					
NOTE 3: This noise is applied in OFDM symbols #0, #4, #7, #11 of a subframe overlapping with the aggressor ABS.					
NOTE 4: This noise is applied in all OFDM symbols of a subframe overlapping with aggressor non-ABS					
NOTE 5: ABS pattern as defined in [9].					
NOTE 6: Time-domain measurement resource restriction pattern for PCell measurements as defined in [7]					
NOTE 7: As configured according to the time-domain measurement resource restriction pattern for CSI measurements defined in [7].					
NOTE 8: The number of control OFDM symbols is not available for ABS and is 2 for the subframe indicated by "0" of ABS pattern.					
NOTE 9: Downlink physical channel setup in Cell 2 and Cell 3 in accordance with Annex C.3.3 applying OCNG pattern as defined in Annex A.5.					
NOTE 10: The number of the CRS ports in Cell 1, Cell 2 and Cell 3 is the same.					
NOTE 11: SIB-1 will not be transmitted in Cell 2 and Cell 3 in this test.					

Table 8.2.1.2.3A-2: Minimum Performance Transmit Diversity (FRC)

Test Number	Reference Channel	OCNG Pattern			Propagation Conditions (NOTE 1)			Correlation Matrix and Antenna Configuration (NOTE 2)	Reference Value		UE Categor
		Cell 1	Cell 2	Cell 3	Cell 1	Cell 2	Cell 3		Fraction of Maximum Throughput (%) NOTE 5	SNR (dB) (NOTE 3)	
1	R.11-4 FDD NOTE 4	OP.1 FDD	OP.1 FDD	OP.1 FDD	EVA5	EVA5	EVA5	2x2 Medium	70	3.4	≥2

NOTE 1: The propagation conditions for Cell 1, Cell 2 and Cell 3 are statistically independent.

NOTE 2: The correlation matrix and antenna configuration apply for Cell 1, Cell 2 and Cell 3.

NOTE 3: SNR corresponds to  $E_s/N_{oc2}$  of cell 1.

NOTE 4: Cell 1 Reference channel is modified: PDSCH other than SIB1/paging and its associated PDCCH/PCFICH are transmitted in the serving cell subframe when the subframe is overlapped with the ABS subframe of aggressor cell and the subframe is available in the definition of the reference channel.

NOTE 5: The maximum Throughput is calculated from the total Payload in 9 subframes, averaged over 40ms.

#### 8.2.1.2.4 Enhanced Performance Requirement Type A - 2 Tx Antenna Ports with TM3 interference model

The requirements are specified in Table 8.2.1.2.4-2, with the addition of parameters in Table 8.2.1.2.4-1 and the downlink physical channel setup according to Annex C.3.2. The purpose is to verify the performance of transmit diversity (SFBC) with 2 transmit antennas when the PDSCH transmission in the serving cell is interfered by PDSCH of two dominant interfering cells applying transmission mode 3 interference model defined in clause B.5.2. In Table 8.2.1.2.4-1, Cell 1 is the serving cell, and Cell 2, 3 are interfering cells. The downlink physical channel setup is according to Annex C.3.2 for each of Cell 1, Cell 2 and Cell 3, respectively.

**Table 8.2.1.2.4-1: Test Parameters for Transmit diversity Performance (FRC) with TM3 interference model**

Parameter		Unit	Cell 1	Cell 2	Cell 3
Downlink power allocation	$\rho_A$	dB	-3	-3	-3
	$\rho_B$	dB	-3 (NOTE 1)	-3	-3
	$\sigma$	dB	0	0	0
Cell-specific reference signals			Antenna ports 0,1	Antenna ports 0,1	Antenna ports 0,1
$N_{oc}$ at antenna port		dBm/15kHz	-98	N/A	N/A
DIP (NOTE 2)		dB	N/A	-2.23	-8.06
BW <sub>Channel</sub>		MHz	10	10	10
Cyclic Prefix			Normal	Normal	Normal
Cell Id			0	1	2
Number of control OFDM symbols			2	2	2
PDSCH transmission mode			2	N/A	N/A
Interference model			N/A	As specified in clause B.5.2	As specified in clause B.5.2
Probability of occurrence of transmission rank in interfering cells	Rank 1	%	N/A	80	80
	Rank 2	%	N/A	20	20
Reporting interval		ms	5	N/A	N/A
Reporting mode			PUCCH 1-0	N/A	N/A
Physical channel for CQI reporting			PUSCH(Note 5)	N/A	N/A
cqi-pmi-ConfigurationIndex			2	N/A	N/A
NOTE 1: $P_B = 1$					
NOTE 2: The respective received power spectral density of each interfering cell relative to $N_{oc}$ is defined by its associated DIP value as specified in clause B.5.1.					
NOTE 3: Cell 1 is the serving cell. Cell 2, 3 are the interfering cells.					
NOTE 4: Cell 2 transmission is delayed with respect to Cell 1 by 0.33 ms and Cell 3 transmission is delayed with respect to Cell 1 by 0.67 ms.					
NOTE 5: To avoid collisions between CQI reports and HARQ-ACK it is necessary to report both on PUSCH instead of PUCCH. PDCCH DCI format 0 shall be transmitted in downlink SF#1 and #6 to allow periodic CQI to multiplex with the HARQ-ACK on PUSCH in uplink subframe SF#5 and #0.					

**Table 8.2.1.2.4-2: Enhanced Performance Requirement Type A, Transmit Diversity (FRC) with TM3 interference model**

Test Number	Reference Channel	OCNG Pattern			Propagation Conditions			Correlation Matrix and Antenna Configuration (NOTE 3)	Reference Value		UE Category
		Cell 1	Cell 2	Cell 3	Cell 1	Cell 2	Cell 3		Fraction of Maximum Throughput (%)	SINR (dB) (NOTE 2)	
1	R.46 FDD	OP. 1 FDD	N/A	N/A	EV A70	EV A70	EV A70	2x2 Low	70	-1.1	≥1
NOTE 1: The propagation conditions for Cell 1, Cell 2 and Cell 3 are statistically independent.											
NOTE 2: SINR corresponds to $E_s/N_{oc}$ of Cell 1 as defined in clause 8.1.1.											
NOTE 3: Correlation matrix and antenna configuration parameters apply for each of Cell 1, Cell 2 and Cell 3.											

### 8.2.1.2.5 Enhanced Performance Requirement Type B - 2 Tx Antenna Ports with TM2 interference model

The requirements are specified in Table 8.2.1.2.5-2, with the addition of parameters in Table 8.2.1.2.5-1 and the downlink physical channel setup according to Annex C.3.2. The purpose is to verify the performance of transmit diversity (SFBC) with 2 transmit antennas when the PDSCH transmission in the serving cell is interfered by PDSCH of two interfering cells applying transmission mode 2 interference model defined in clause B.6.1. In Table 8.2.1.2.5-1, Cell 1 is the serving cell, and Cell 2, 3 are interfering cells. The downlink physical channel setup is according to Annex C.3.2 for each of Cell 1, Cell 2 and Cell 3, respectively.

**Table 8.2.1.2.5-1: Test Parameters for Transmit Diversity Performance (FRC) with TM2 interference model**

Parameter		Unit	Cell 1	Cell 2	Cell 3
Downlink power allocation	$\rho_A$	dB	-3	-3	-3
	$\rho_B$	dB	-3 (Note 1)	-3	-3
	$\sigma$	dB	0	0	0
Cell-specific reference signals			Antenna ports 0,1	Antenna ports 0,1	Antenna ports 0,1
$N_{oc}$ at antenna port		dBm/15kHz	-98		
$\bar{E}_s/N_{oc}$		dB	N/A	13.91	3.34
BW <sub>Channel</sub>		MHz	10	10	10
Cyclic Prefix			Normal	Normal	Normal
Cell Id			0	6	1
Number of control OFDM symbols			3	3	3
CFI indicated in PCFICH			3	3	3
PDSCH transmission mode			2	2	2
Interference model			N/A	As specified in clause B.6.1	As specified in clause B.6.1
MBSFN			Not configured	Not configured	Not configured
Time offset to cell 1		us	N/A	2	3
Frequency offset to cell 1		Hz	N/A	200	300
NeighCellsInfo-r12 (Note 3)	p-aList-r12		N/A	{dB-6, dB-3, dB0}	{dB-6, dB-3, dB0}
	transmissionModeList-r12		N/A	{2,3,4,8,9}	{2,3,4,8,9}
Note 1: $P_B = 1$					
Note 2: Cell 1 is the serving cell. Cell 2, 3 are the interfering cells.					
Note 3: NeighCellsInfo-r12 is described in subclause 6.3.2 of [7].					

**Table 8.2.1.2.5-2: Minimum Performance for Enhanced Performance Requirement Type B, Transmit Diversity (FRC) with TM2 interference model**

Test Number	Reference Channel	OCNG Pattern			Propagation Conditions			Correlation Matrix and Antenna Configuration (Note 3)	Reference Value		UE Category
		Cell 1	Cell 2	Cell 3	Cell 1	Cell 2	Cell 3		Fraction of Maximum Throughput (%)	SNR (dB) (Note 2)	
1	R.11-10 FDD	OP. 1 FDD	N/A	N/A	EP A5	EP A5	EP A5	2x2 Low	85	15.5	≥1
Note 1: The propagation conditions for Cell 1, Cell 2 and Cell 3 are statistically independent.											
Note 2: SNR corresponds to $\bar{E}_s/N_{oc}$ of Cell 1 as defined in clause 8.1.1.											
Note 3: Correlation matrix and antenna configuration parameters apply for each of Cell 1, Cell 2 and Cell 3.											

### 8.2.1.2.6 Enhanced Performance Requirement Type B - 2 Tx Antenna Ports with TM9 interference model

The requirements are specified in Table 8.2.1.2.6-2, with the addition of parameters in Table 8.2.1.2.6-1 and the downlink physical channel setup according to Annex C.3.2. The purpose is to verify the performance of transmit diversity (SFBC) with 2 transmit antennas when the PDSCH transmission in the serving cell is interfered by PDSCH of two interfering cells applying transmission mode 9 interference model defined in clause B.6.4. In Table 8.2.1.2.6-1, Cell 1 is the serving cell, and Cell 2, 3 are interfering cells. The downlink physical channel setup is according to Annex C.3.2 for each of Cell 1, Cell 2 and Cell 3, respectively.

**Table 8.2.1.2.6-1: Test Parameters for Transmit Diversity Performance (FRC) with TM9 interference model**

Parameter		Unit	Cell 1	Cell 2	Cell 3
Downlink power allocation	$\rho_A$	dB	-3	0	0
	$\rho_B$	dB	-3 (Note 1)	0	0
	$\sigma$	dB	0	-3	-3
Cell-specific reference signals			Antenna ports 0,1	Antenna ports 0,1	Antenna ports 0,1
$N_{oc}$ at antenna port		dBm/15kHz	-98		
$\bar{E}_s/N_{oc}$		dB	N/A	3.28	0.74
BW <sub>Channel</sub>		MHz	10	10	10
Cyclic Prefix			Normal	Normal	Normal
Cell Id			0	1	6
Number of control OFDM symbols			3	3	3
CFI indicated in PCFICH			3	Random from set {1,2,3}	Random from set {1,2,3}
PDSCH transmission mode			2	9	9
Interference model			N/A	As specified in clause B.6.4	As specified in clause B.6.4
CSI reference signals			N/A	Antenna ports 15,16	Antenna ports 15,16
CSI-RS periodicity and subframe offset $T_{CSI-RS} / \Delta_{CSI-RS}$		Subframes	N/A	10 / 1	10 / 1
CSI reference signal configuration			N/A	6	7
Zero-power CSI-RS configuration $I_{CSI-RS} / ZeroPowerCSI-RS$ bitmap		Subframes / bitmap	N/A	6 / 0100000000 00000	6 / 0010000000 000000
Time offset to cell 1		us	N/A	5	-5
Frequency offset to cell 1		Hz	N/A	600	-600
MBSFN			Not configured	Not configured	Not configured
NeighCellsInfo-r12 (Note 4)	p-aList-r12		N/A	{dB-6, dB-3, dB0}	{dB-6, dB-3, dB0}
	transmissionModeList-r12		N/A	{2,3,4,8,9}	{2,3,4,8,9}
Note 1: $P_B = 1$ Note 2: Cell 1 is the serving cell. Cell 2, 3 are the interfering cells. Note 3: CSI-RS configurations are according to [4] subclause 6.10.5.2. Note 4: NeighCellsInfo-r12 is described in subclause 6.3.2 of [7].					

**Table 8.2.1.2.6-2: Minimum Performance for Enhanced Performance Requirement Type B, Transmit Diversity (FRC) with TM9 interference model**

Test Number	Reference Channel	OCNG Pattern			Propagation Conditions			Correlation Matrix and Antenna Configuration (Note 3)	Reference Value		UE Category
		Cell 1	Cell 2	Cell 3	Cell 1	Cell 2	Cell 3		Fraction of Maximum Throughput (%)	SNR (dB) (Note 2)	
1	R.11-9 FDD	OP.1 FDD	N/A	N/A	EP A5	EP A5	EP A5	2x2 Low	85	8.4	≥1

Note 1: The propagation conditions for Cell 1, Cell 2 and Cell 3 are statistically independent.

Note 2: SNR corresponds to  $E_s/N_{oc}$  of Cell 1 as defined in clause 8.1.1.

Note 3: Correlation matrix and antenna configuration parameters apply for each of Cell 1, Cell 2 and Cell 3.

**8.2.1.2.7 Minimum Requirement 2 Tx Antenna Port (Superposed transmission)**

The requirements are specified in Table 8.2.1.2.7-2, with the addition of the parameters in Table 8.2.1.2.7-1 and the downlink physical channel setup according to Annex C.3.2. The purpose is to verify the minimum performance of transmit diversity (SFBC) with 2 transmitter antennas superposed with simultaneous PDSCH interference.

**Table 8.2.1.2.7-1: Test Parameters for Minimum Requirement 2 Tx Antenna Port - Superposed transmission (FRC)**

Parameter	Unit	Test 1
Downlink power allocation	$\rho_A$	dB
	$\rho_B$	dB
	$\sigma$	dB
$N_{oc}$ at antenna port		dBm/15kHz
PDSCH transmission mode		2
MUSTIdx (Note 2)		11
p-a-must-r14 (Note 3)		N/A
Note 1: $P_B = 1$ .		
Note 2: MUSTIdx is described in subclause 6.3.3 of [4].		
Note 3: p-a-must-r14 is described in subclause 6.3.2 of [7].		

**Table 8.2.1.2.7-2: Minimum Performance for Minimum Requirement 2 Tx Antenna Port - Superposed transmission (FRC)**

Test number	Bandwidth	Reference Channel	OCNG Pattern	Propagation Condition	Correlation Matrix and Antenna Configuration	Reference value		UE Category
						Fraction of Maximum Throughput (%)	SNR (dB)	
1	10 MHz	R.aa FDD	OP.1 FDD	EVA5	2x2 Low	70	14.1	≥1

**8.2.1.3 Open-loop spatial multiplexing performance****8.2.1.3.1 Minimum Requirement 2 Tx Antenna Port**

For single carrier, the requirements are specified in Table 8.2.1.3.1-2, with the addition of the parameters in Table 8.2.1.3.1-1 and the downlink physical channel setup according to Annex C.3.2.

For CA with 2 DL CC, the requirements are specified in Table 8.2.1.3.1-4, with the addition of the parameters in Table 8.2.1.3.1-3 and the downlink physical channel setup according to Annex C.3.2. The purpose is to verify the performance of large delay CDD with 2 transmitter antennas.

For CA with 3 DL CCs, the requirements are specified in Table 8.2.1.3.1-6, based on single carrier requirement specified in Table 8.2.1.3.1-5, with the addition of the parameters in Table 8.2.1.3.1-3 and the downlink physical channel setup according to Annex C.3.2.

For CA with 4 DL CCs, the requirements are specified in Table 8.2.1.3.1-7, based on single carrier requirement specified in Table 8.2.1.3.1-5, with the addition of the parameters in Table 8.2.1.3.1-3 and the downlink physical channel setup according to Annex C.3.2.

For CA with 5 DL CCs, the requirements are specified in Table 8.2.1.3.1-8, based on single carrier requirement specified in Table 8.2.1.3.1-5, with the addition of the parameters in Table 8.2.1.3.1-3 and the downlink physical channel setup according to Annex C.3.2.

For CA with 6 DL CCs, the requirements are specified in Table 8.2.1.3.1-9, based on single carrier requirement specified in Table 8.2.1.3.1-5, with the addition of the parameters in Table 8.2.1.3.1-3 and the downlink physical channel setup according to Annex C.3.2.

For CA with 7 DL CCs, the requirements are specified in Table 8.2.1.3.1-10, based on single carrier requirement specified in Table 8.2.1.3.1-5, with the addition of the parameters in Table 8.2.1.3.1-3 and the downlink physical channel setup according to Annex C.3.2.

The test coverage for different number of component carriers is defined in 8.1.2.4.

**Table 8.2.1.3.1-1: Test Parameters for Large Delay CDD (FRC)**

Parameter	Unit	Test 1-4	
Downlink power allocation	$\rho_A$	dB	-3
	$\rho_B$	dB	-3 (NOTE 1)
	$\sigma$	dB	0
$N_{oc}$ at antenna port	dBm/15kHz	-98	
PDSCH transmission mode		3	
NOTE 1: $P_B = 1$ .			
NOTE 2: Void.			
NOTE 3: Void.			

**Table 8.2.1.3.1-2: Minimum performance Large Delay CDD (FRC)**

Test num	Bandwidth	Reference channel	OCNG pattern	Propagation condition	Correlation matrix and antenna config.	Reference value		UE category
						Fraction of maximum Throughput (%)	SNR (dB)	
1 (NOTE 4)	10 MHz	R.11 FDD	OP.1 FDD	EVA70	2x2 Low	70	13.0	$\geq 2$
2 (NOTE 3)	5 MHz	R.11-2 FDD	OP.1 FDD	EVA70	2x2 Low	70	12.7	$\geq 2$
3	10 MHz	R.35 FDD	OP.1 FDD	EVA200	2x2 Low	70	20.2	$\geq 2$
4	10 MHz	R.35-4 FDD	OP.1 FDD	ETU600	2x2 Low	70	20.8	$\geq 2$
NOTE 1: Void.								
NOTE 2: Test 1 may not be executed for UE-s for which Test 1 or 2 in Table 8.2.1.3.1-4 is applicable.								
NOTE 3: Test case applicability is defined in 8.1.2.1.								
NOTE 4: For UE that supports CRS interference handling, the CRS assistance information defined in [7] is provided. The CRS assistance information includes two aggressor cells with 2 CRS ports and cell ID of aggressor cells are 1 and 128. For UE that does not support CRS interference handling, CRS assistance information is not provided.								



Table 8.2.1.3.1-3: Test Parameters for Large Delay CDD (FRC) for CA

Parameter	Unit	Value	
Downlink power allocation	$\rho_A$	dB	-3
	$\rho_B$	dB	-3 (NOTE 1)
	$\sigma$	dB	0
$N_{oc}$ at antenna port	dBm/15kHz	-98	
PDSCH transmission mode		3	
NOTE 1: $P_B = 1$ .			
NOTE 2: PUCCH format 1b with channel selection is used to feedback ACK/NACK for Tests in Table 8.2.1.3.1-4, PUCCH format 3 is used to feedback ACK/NACK for Tests in Table 8.2.1.3.1-6.			
NOTE 3: The same PDSCH transmission mode is applied to each component carrier.			

Table 8.2.1.3.1-4: Minimum performance Large Delay CDD (FRC) for CA with 2DL CCs

Test num	Bandwidth	Reference channel	OCNG pattern	Propagation condition	Correlation matrix and antenna config.	Reference value		UE category
						Fraction of maximum Throughput (%)	SNR (dB)	
1 (NOTE 2)	2x10 MHz	R.11 FDD	OP.1 FDD (NOTE 1)	EVA70	2x2 Low	70	13.7	$\geq 3$
2 (NOTE 2)	2x20 MHz	R.30 FDD	OP.1 FDD (NOTE 1)	EVA70	2x2 Low	70	13.2	$\geq 5$
3	2x5 MHz	R.11-2 FDD	OP.1 FDD	EVA70	2x2 Low	70	12.7	$\geq 2$
4	10MHz+5 MHz	R.11 FDD for 10MHz CC <sub>1</sub>	OP.1 FDD (NOTE 1)	EVA70	2x2 Low	70	13.0	$\geq 3$
		R.11-2 FDD for 5MHz CC	OP.1 FDD (NOTE 1)			70	12.7	
5	15MHz+5 MHz	R.11-7 FDD for 15MHz CC	OP.1 FDD (NOTE 1)	EVA70	2x2 Low	70	12.8	$\geq 3$
		R.11-2 FDD for 5MHz CC	OP.1 FDD (NOTE 1)			70	12.7	
NOTE 1: The OCNG pattern applies for each CC.								
NOTE 2: Void								
NOTE 3: The applicability of requirements for different CA configurations and bandwidth combination sets is defined in 8.1.2.3.								

Table 8.2.1.3.1-5: Single carrier performance for multiple CA configurations

Band-width	Reference channel	OCNG pattern	Propagation condition	Correlation matrix and antenna config.	Reference value	
					Fraction of maximum throughput (%)	SNR (dB)
1.4MHz	R.11-5 FDD	OP. 1 FDD	EVA70	2x2 Low	70	13.6
3MHz	R.11-6 FDD	OP. 1 FDD	EVA70	2x2 Low	70	12.3
5MHz	R.11-2 FDD	OP. 1 FDD	EVA70	2x2 Low	70	12.3
10 MHz	R.11 FDD	OP. 1 FDD	EVA70	2x2 Low	70	12.9
15MHz	R.11-7 FDD	OP. 1 FDD	EVA70	2x2 Low	70	12.8
20MHz	R.30 FDD	OP. 1 FDD	EVA70	2x2 Low	70	12.9

Table 8.2.1.3.1-6: Minimum performance (FRC) based on single carrier performance for CA with 3 DL CCs

Test num.	CA Band-width combination	Requirement	UE category
1	3x20MHz	As specified in Table 8.2.1.3.1-5 per CC	≥5
2	20MHz+20MHz+15MHz	As specified in Table 8.2.1.3.1-5 per CC	≥5
3	20MHz+20MHz+10MHz	As specified in Table 8.2.1.3.1-5 per CC	≥5
4	20MHz+15MHz+15MHz	As specified in Table 8.2.1.3.1-5 per CC	≥5
5	20MHz+15MHz+10MHz	As specified in Table 8.2.1.3.1-5 per CC	≥5
6	20MHz+10MHz+10MHz	As specified in Table 8.2.1.3.1-5 per CC	≥5
7	15MHz+15MHz+10MHz	As specified in Table 8.2.1.3.1-5 per CC	≥5
8	20MHz+10MHz+5MHz	As specified in Table 8.2.1.3.1-5 per CC	≥5
9	20MHz+15MHz+5MHz	As specified in Table 8.2.1.3.1-5 per CC	≥5
10	10MHz+10MHz+5MHz	As specified in Table 8.2.1.3.1-5 per CC	≥5
11	5MHz+5MHz+20MHz	As specified in Table 8.2.1.3.1-5 per CC	≥5
12	3x10MHz	As specified in Table 8.2.1.3.1-5 per CC	≥5
13	5MHz+5MHz+10MHz	As specified in Table 8.2.1.3.1-5 per CC	≥5

NOTE 1: The applicability of requirements for different CA configurations and bandwidth combination sets is defined in 8.1.2.3

Table 8.2.1.3.1-7: Minimum performance (FRC) based on single carrier performance for CA with 4 DL CCs

Test num.	CA Band-width combination	Requirement	UE category
1	4x20MHz	As specified in Table 8.2.1.3.1-5 per CC	≥8
2	10MHz+20MHz+20MHz+20MHz	As specified in Table 8.2.1.3.1-5 per CC	≥8
3	10MHz+10MHz+20MHz+20MHz	As specified in Table 8.2.1.3.1-5 per CC	≥8
4	5MHz+10MHz+20MHz+20MHz	As specified in Table 8.2.1.3.1-5 per CC	≥8
5	5MHz+10MHz+10MHz+20MHz	As specified in Table 8.2.1.3.1-5 per CC	≥8
6	15+3x20MHz	As specified in Table 8.2.1.3.1-5 per CC	≥8
7	2x15+2x20MHz	As specified in Table 8.2.1.3.1-5 per CC	≥8
8	10+15+2x20MHz	As specified in Table 8.2.1.3.1-5 per CC	≥8
9	3x10+20MHz	As specified in Table 8.2.1.3.1-5 per CC	≥8
10	2x5+2x20MHz	As specified in Table 8.2.1.3.1-5 per CC	≥8
11	2x5+10+20MHz	As specified in Table 8.2.1.3.1-5 per CC	≥8
12	4x10MHz	As specified in Table 8.2.1.3.1-5 per CC	≥8

NOTE 1: The applicability of requirements for different CA configurations and bandwidth combination sets is defined in 8.1.2.3

**Table 8.2.1.3.1-8: Minimum performance (FRC) based on single carrier performance for CA with 5 DL CCs**

Test num.	CA Band-width combination	Requirement	UE category
1	5x20MHz	As specified in Table 8.2.1.3.1-5 per CC	8, ≥11
2	15MHz+4x20MHz	As specified in Table 8.2.1.3.1-5 per CC	8, ≥11
3	10MHz+4x20MHz	As specified in Table 8.2.1.3.1-5 per CC	8, ≥11
4	2x10MHz+3x20MHz	As specified in Table 8.2.1.3.1-5 per CC	8, ≥11
5	5MHz+10MHz+3x20MHz	As specified in Table 8.2.1.3.1-5 per CC	8, ≥11
6	3x10MHz+2x20MHz	As specified in Table 8.2.1.3.1-5 per CC	8, ≥11
7	4x10MHz+20MHz	As specified in Table 8.2.1.3.1-5 per CC	8, ≥11

NOTE 1: The applicability of requirements for different CA configurations and bandwidth combination sets is defined in 8.1.2.3

**Table 8.2.1.3.1-9: Minimum performance (FRC) based on single carrier performance for CA with 6 DL CCs**

Test num.	CA Band-width combination	Requirement	UE category
1	6x20MHz	As specified in Table 8.2.1.3.1-5 per CC	8, ≥11

NOTE 1: The applicability of requirements for different CA configurations and bandwidth combination sets is defined in 8.1.2.3

**Table 8.2.1.3.1-10: Minimum performance (FRC) based on single carrier performance for CA with 7 DL CCs**

Test num.	CA Band-width combination	Requirement	UE category
1	7x20MHz	As specified in Table 8.2.1.3.1-5 per CC	8, ≥11

NOTE 1: The applicability of requirements for different CA configurations and bandwidth combination sets is defined in 8.1.2.3

**8.2.1.3.1A Soft buffer management test**

For CA, the requirements are specified in Table 8.2.1.3.1A-2, with the addition of the parameters in Table 8.2.1.3.1A-1 and the downlink physical channel setup according to Annex C.3.2. The purpose is to verify the UE performance with proper instantaneous buffer implementation. The test points are applied to UE category and bandwidth combination with maximum aggregated bandwidth as specified in Table 8.2.1.3.1A-3.

**Table 8.2.1.3.1A-1: Test Parameters for soft buffer management test (FRC) for CA**

Parameter	Unit	Test 1-7	
Downlink power allocation	$\rho_A$	dB	-3
	$\rho_B$	dB	-3 (NOTE 1)
	$\sigma$	dB	0
$N_{oc}$ at antenna port	dBm/15kHz	-98	
PDSCH transmission mode		3	
NOTE 1: $P_B = 1$ .			
NOTE 2: For CA test cases, PUCCH format 1b with channel selection is used to feedback ACK/NACK.			
NOTE 3: For CA test cases, the same PDSCH transmission mode is applied to each component carrier.			

Table 8.2.1.3.1A-2: Minimum performance soft buffer management test (FRC) for CA

Test num	Bandwidth	Reference channel	OCNG pattern	Propagation condition	Correlation matrix and antenna config.	Reference value	
						Fraction of maximum Throughput (%)	SNR (dB)
1	2x20 MHz	R.30 FDD	OP.1 FDD (NOTE 1)	EVA70	2x2 Low	70	13.2
2	15MHz + 10MHz	R.35-2 FDD for 15MHz CC	OP.1 FDD (NOTE 1)	EVA5	2x2 Low	70	15.1
		R.35-3 FDD for 10MHz CC	OP.1 FDD (NOTE 1)			70	15.1
3	20MHz + 10MHz	R.30 FDD for 20MHz CC	OP.1 FDD (NOTE 1)	EVA70	2x2 Low	70	13.5
		R.11 FDD for 10MHz CC	OP.1 FDD (NOTE 1)			70	13.5
4	20MHz + 15MHz	R.30 FDD for 20MHz CC	OP.1 FDD (NOTE 1)	EVA70	2x2 Low	70	13.5
		R.30-1 FDD for 15MHz CC	OP.1 FDD (NOTE 1)			70	13.5
5	2x20 MHz	R.35-1 FDD	OP.1 FDD (NOTE 1)	EVA5	2x2 Low	70	15.8
6	20MHz + 10MHz	R.35-1 FDD for 20MHz CC	OP.1 FDD (NOTE 1)	EVA5	2x2 Low	70	15.9
		R.35-3 FDD for 10MHz CC	OP.1 FDD (NOTE 1)			70	15.9
7	20MHz + 15MHz	R.35-1 FDD for 20MHz CC	OP.1 FDD (NOTE 1)	EVA5	2x2 Low	70	15.9
		R.35-2 FDD for 15MHz CC	OP.1 FDD (NOTE 1)			70	15.9

NOTE 1: For CA test cases, the OCNG pattern applies for each CC.

NOTE 2: For Test 2, 3, 4, 6, 7 the Fraction of maximum Throughput applies to each CC.

NOTE 3: The applicability of the requirements for different CA configurations and bandwidth combination sets is defined in 8.1.2.3.

Table 8.2.1.3.1A-3: Test points for soft buffer management tests for CA

UE category	Bandwidth combination with maximum aggregated bandwidth (NOTE 1)			
	2x20MHz	15MHz+10MHz	20MHz+10MHz	20MHz+15MHz
3	1	2	3	4
4	5	N/A	6	7

NOTE 1: Maximum over all supported CA configurations and bandwidth combination sets according to Table 5.6A.1-1 and Table 5.6A.1-2.

## 8.2.1.3.1B Enhanced Performance Requirement Type C –2Tx Antenna Ports

The requirements are specified in Table 8.2.1.3.1B-2, with the addition of the parameters in Table 8.2.1.3.1B-1 and the downlink physical channel setup according to Annex C.3.2. The purpose is to verify the performance of large delay CDD with 2 transmitter antennas.

Table 8.2.1.3.1B-1: Test Parameters for Large Delay CDD (FRC)

Parameter	Unit	Test 1	
Downlink power allocation	$\rho_A$	dB	-3
	$\rho_B$	dB	-3 (NOTE 1)
	$\sigma$	dB	0
$N_{oc}$ at antenna port	dBm/15kHz	-98	
PDSCH transmission mode		3	
NOTE 1: $P_B = 1$ .			

**Table 8.2.1.3.1B-2: Enhanced Performance Requirement Type C for Large Delay CDD (FRC)**

Test num	Bandwidth	Reference channel	OCNG pattern	Propagation condition	Correlation matrix and antenna config.	Reference value		UE category
						Fraction of maximum Throughput (%)	SNR (dB)	
1	10 MHz	R.11 FDD	OP.1 FDD	EVA70	2x2 Medium	70	17.8	≥2

### 8.2.1.3.1C Enhanced Performance Requirement Type C - 2 Tx Antenna Ports with TM1 interference

The requirements are specified in Table 8.2.1.3.1C-2, with the addition of parameters in Table 8.2.1.3.1C-1 and the downlink physical channel setup according to Annex C.3.2. The purpose is to verify the performance of open-loop spatial multiplexing performance with 2 transmit antennas when the PDSCH transmission in the serving cell is interfered by PDSCH of one dominant interfering cell with transmission mode 1. In Table 8.2.1.3.1C-1, Cell 1 is the serving cell, and Cell 2 is interfering cells. The downlink physical channel setup is according to Annex C.3.2 for each of Cell 1 and Cell 2 respectively.

**Table 8.2.1.3.1C-1 Test parameters for Larger Delay CDD (FRC) with TM1 interference**

Parameter	Unit	Cell 1	Cell 2
Bandwidth	MHz	10 MHz	
Downlink power allocation	$\rho_A$	-3	0
	$\rho_B$	-3 (NOTE 1)	0
	$\sigma$	0	0
Cell-specific reference signals		Antenna ports 0,1	Antenna port 0
Cyclic Prefix		Normal	Normal
Cell ID		0	1
Transmission mode		3	NOTE 2
$N_{oc}$ at antenna port	dBm/15kHz	-98	N/A
$\bar{E}_s/N_{oc}$ (NOTE 3)	dB	Reference Value in Table 8.2.1.3.1C-2	12.95
Correlation and antenna configuration		Medium (2x2)	Medium(1x2)
Number of OFDM symbols for PDCCH		2	N/A
Max number of HARQ transmissions		4	N/A
Redundancy version coding sequence		{0,1,2,3}	N/A
NOTE 1: $P_B = 1$			
NOTE 2: Downlink physical channel setup in Cell 2 in accordance with Annex C.3.2 applying OCNG pattern OP.5 FDD as defined in Annex A.5.1.5.			
NOTE 3: Cell 1 is the serving cell. Cell 2 is the interfering cell.			
NOTE 4: All cells are time-synchronous.			
NOTE 5: SIB-1 will not be transmitted in Cell2 in this test.			

**Table 8.2.1.3.1C-2 Enhanced Performance Requirement Type C, Larger Delay CDD (FRC) with TM1 interference**

Test Number	Reference Channel	OCNG Pattern		Propagation Conditions (NOTE 1)		Reference Value		UE Category
		Cell 1	Cell 2	Cell 1	Cell 2	Fraction of Maximum Throughput (%)	SNR (dB) (NOTE 2)	
1	R.11-8 FDD	OP.1 FDD	OP.5 FDD	EVA70	EVA70	70	19.9	≥2

NOTE 1: The propagation conditions for Cell 1 and Cell 2 are statistically independent.  
NOTE 2: SNR corresponds to  $\bar{E}_s/N_{oc}$  of Cell 1.

**8.2.1.3.2 Minimum Requirement 4 Tx Antenna Port**

The requirements are specified in Table 8.2.1.3.2-2, with the addition of the parameters in Table 8.2.1.3.2-1 and the downlink physical channel setup according to Annex C.3.2. The purpose is to verify the performance of large delay CDD with 4 transmitter antennas.

**Table 8.2.1.3.2-1: Test Parameters for Large Delay CDD (FRC)**

Parameter	Unit	Test 1
Downlink power allocation	$\rho_A$	dB
	$\rho_B$	dB
	$\sigma$	dB
$N_{oc}$ at antenna port	dBm/15kHz	-98
PDSCH transmission mode		3

NOTE 1:  $P_B = 1$

**Table 8.2.1.3.2-2: Minimum performance Large Delay CDD (FRC)**

Test number	Bandwidth	Reference Channel	OCNG Pattern	Propagation Condition	Correlation Matrix and Antenna Configuration	Reference value		UE Category
						Fraction of Maximum Throughput (%)	SNR (dB)	
1	10 MHz	R.14 FDD	OP.1 FDD	EVA70	4x2 Low	70	14.3	≥2

**8.2.1.3.3 Minimum Requirement 2 Tx Antenna Port (demodulation subframe overlaps with aggressor cell ABS)**

The requirements for non-MBSFN ABS are specified in Table 8.2.1.3.3-2, with the addition of parameters in Table 8.2.1.3.3-1 and the downlink physical channel setup according to Annex C.3.2 and Annex C.3.3.

The requirements for MBSFN ABS are specified in Table 8.2.1.3.3-4, with the addition of parameters in Table 8.2.1.3.3-3 and the downlink physical channel setup according to Annex C.3.2 and Annex C.3.3.

The purpose is to verify the performance of large delay CDD with 2 transmitter antennas if the PDSCH transmission in the serving cell takes place in subframes that overlap with ABS [9] of the aggressor cell. In Tables 8.2.1.3.3-1 and 8.2.1.3.3-3, Cell 1 is the serving cell, and Cell 2 is the aggressor cell. The downlink physical channel setup for Cell 1 is according to Annex C.3.2 and for Cell 2 is according to Annex C.3.3, respectively.

Table 8.2.1.3.3-1: Test Parameters for Large Delay CDD (FRC) – Non-MBSFN ABS

Parameter		Unit	Cell 1	Cell 2
Downlink power allocation	$\rho_A$	dB	-3	-3
	$\rho_B$	dB	-3 (NOTE 1)	-3
	$\sigma$	dB	0	N/A
$N_{oc}$ at antenna port	$N_{oc1}$	dBm/15kHz	-102 (NOTE 2)	N/A
	$N_{oc2}$	dBm/15kHz	-98 (NOTE 3)	N/A
	$N_{oc3}$	dBm/15kHz	-94.8 (NOTE 4)	N/A
$E_s/N_{oc2}$		dB	Reference Value in Table 8.2.1.3.3-2	6
$BW_{Channel}$		MHz	10	10
Subframe Configuration			Non-MBSFN	Non-MBSFN
Cell Id			0	1
Time Offset between Cells		$\mu s$	2.5 (synchronous cells)	
ABS pattern (NOTE 5)			N/A	11000100, 11000000, 11000000, 11000000, 11000000
RLM/RRM Measurement Subframe Pattern (NOTE 6)			10000000 10000000 10000000 10000000 10000000	N/A
CSI Subframe Sets (NOTE 7)	$C_{CSI,0}$		11000100 11000000 11000000 11000000 11000000	N/A
	$C_{CSI,1}$		00111011 00111111 00111111 00111111 00111111	N/A
Number of control OFDM symbols			2	2
PDSCH transmission mode			3	N/A
Cyclic prefix			Normal	Normal
NOTE 1: $P_B = 1$ .				
NOTE 2: This noise is applied in OFDM symbols #1, #2, #3, #5, #6, #8, #9, #10, #12, #13 of a subframe overlapping with the aggressor ABS.				
NOTE 3: This noise is applied in OFDM symbols #0, #4, #7, #11 of a subframe overlapping with the aggressor ABS.				
NOTE 4: This noise is applied in all OFDM symbols of a subframe overlapping with aggressor non-ABS				
NOTE 5: ABS pattern as defined in [9].				
NOTE 6: Time-domain measurement resource restriction pattern for PCell measurements as defined in [7].				
NOTE 7: As configured according to the time-domain measurement resource restriction pattern for CSI measurements defined in [7].				
NOTE 8: Cell 1 is the serving cell. Cell 2 is the aggressor cell. The number of the CRS ports in Cell1 and Cell2 is the same.				
NOTE 9: SIB-1 will not be transmitted in Cell2 in this test.				

Table 8.2.1.3.3-2: Minimum Performance Large Delay CDD (FRC) – Non-MBSFN ABS

Test Number	Reference Channel	OCNG Pattern		Propagation Conditions (Note 1)		Correlation Matrix and Antenna Configuration	Reference Value		UE Category
		Cell 1	Cell 2	Cell 1	Cell 2		Fraction of Maximum Throughput (%) Note 5	SNR (dB) (Note 2)	
1	R.11 FDD Note 4	OP.1 FDD	OP.1 FDD	EVA 5	EVA 5	2x2 Low	70	13.3	≥2
<p>Note 1: The propagation conditions for Cell 1 and Cell2 are statistically independent.</p> <p>Note 2: SNR corresponds to <math>E_s/N_{oc2}</math> of cell 1.</p> <p>Note 3: The correlation matrix and antenna configuration apply for Cell 1 and Cell 2.</p> <p>Note 4: Cell 1 Reference channel is modified: PDSCH other than SIB1/paging and its associated PDCCH/PCFICH are transmitted in the serving cell subframe when the subframe is overlapped with the ABS subframe of aggressor cell and the subframe is available in the definition of the reference channel.</p> <p>Note 5: The maximum Throughput is calculated from the total Payload in 9 subframes, averaged over 40ms.</p>									



Table 8.2.1.3.3-3: Test Parameters for Large Delay CDD (FRC) – MBSFN ABS

Parameter		Unit	Cell 1	Cell 2
Downlink power allocation	$\rho_A$	dB	-3	-3
	$\rho_B$	dB	-3 (Note 1)	-3
	$\sigma$	dB	0	N/A
$N_{oc}$ at antenna port	$N_{oc1}$	dBm/15kHz	-102 (Note 2)	N/A
	$N_{oc2}$	dBm/15kHz	-98 (Note 3)	N/A
	$N_{oc3}$	dBm/15kHz	-94.8 (Note 4)	N/A
$E_s/N_{oc2}$		dB	Reference Value in Table 8.2.1.3.3-4	6
$BW_{Channel}$		MHz	10	10
Subframe Configuration			Non-MBSFN	MBSFN
Cell Id			0	126
Time Offset between Cells		$\mu$ s	2.5 (synchronous cells)	
ABS pattern (Note 5)			N/A	0001000000 0100000010 0000001000 0000000000
RLM/RRM Measurement Subframe Pattern (Note 6)			0001000000 0100000010 0000001000 0000000000	N/A
CSI Subframe Sets (Note 7)	$C_{CSI,0}$		0001000000 0100000010 0000001000 0000000000	N/A
	$C_{CSI,1}$		1110111111 1011111101 1111110111 1111111111	N/A
MBSFN Subframe Allocation (Note 10)			N/A	001000 100001 000100 000000
Number of control OFDM symbols			2	2
PDSCH transmission mode			3	N/A
Cyclic prefix			Normal	Normal
<p>Note 1: <math>P_B = 1</math>.</p> <p>Note 2: This noise is applied in OFDM symbols #1, #2, #3, #4, #5, #6, #7, #8, #9, #10, #11, #12, #13 of a subframe overlapping with the aggressor ABS.</p> <p>Note 3: This noise is applied in OFDM symbol #0 of a subframe overlapping with the aggressor ABS.</p> <p>Note 4: This noise is applied in all OFDM symbols of a subframe overlapping with aggressor non-ABS.</p> <p>Note 5: ABS pattern as defined in [9]. The 4<sup>th</sup>, 12<sup>th</sup>, 19<sup>th</sup> and 27<sup>th</sup> subframes indicated by ABS pattern are MBSFN ABS subframes.</p> <p>Note 6: Time-domain measurement resource restriction pattern for PCell measurements as defined in [7].</p> <p>Note 7: As configured according to the time-domain measurement resource restriction pattern for CSI measurements defined in [7].</p> <p>Note 8: Cell 1 is the serving cell. Cell 2 is the aggressor cell. The number of the CRS ports in Cell1 and Cell2 is the same.</p> <p>Note 9: SIB-1 will not be transmitted in Cell2 in this test.</p> <p>Note 10: MBSFN Subframe Allocation as defined in [7], four frames with 24 bits is chosen for MBSFN subframe allocation.</p> <p>Note 11: The maximum number of uplink HARQ transmission is <math>\leq 2</math> so that each PHICH channel transmission is in a subframe protected by MBSFN ABS in this test.</p>				

Table 8.2.1.3.3-4: Minimum Performance Large Delay CDD (FRC) – MBSFN ABS

Test Number	Reference Channel	OCNG Pattern		Propagation Conditions (Note 2)		Correlation Matrix and Antenna Configuration	Reference Value		UE Category
		Cell 1	Cell 2	Cell 1	Cell 2		Fraction of Maximum Throughput (%) Note 5	SNR (dB) (Note 2)	
1	R.11 FDD Note 4	OP.1 FDD	OP.1 FDD	EVA 5	EVA 5	2x2 Low	70	12.0	≥2
Note 1:	The propagation conditions for Cell 1 and Cell2 are statistically independent.								
Note 2:	SNR corresponds to $E_s/N_{oc2}$ of cell 1.								
Note 3:	The correlation matrix and antenna configuration apply for Cell 1 and Cell 2.								
Note 4:	Cell 1 Reference channel is modified: PDSCH other than SIB1/paging and its associated PDCCH/PCFICH are transmitted in the serving cell subframe when the subframe is overlapped with the ABS subframe of aggressor cell and the subframe is available in the definition of the reference channel.								
Note 5:	The maximum Throughput is calculated from the total Payload in 4 subframes, averaged over 40ms.								

#### 8.2.1.3.4 Minimum Requirement 2 Tx Antenna Port (demodulation subframe overlaps with aggressor cell ABS and CRS assistance information are configured)

The requirements for non-MBSFN ABS are specified in Table 8.2.1.3.4-2, with the addition of parameters in Table 8.2.1.3.4-1. The purpose is to verify the performance of large delay CDD with 2 transmit antennas if the PDSCH transmission in the serving cell takes place in subframes that overlap with ABS [9] of the aggressor cells with CRS assistance information. In Table 8.2.1.3.4-1, Cell 1 is the serving cell, and Cell 2 and Cell 3 are the aggressor cells. The downlink physical channel setup for Cell 1 is according to Annex C.3.2 and for Cell 2 and Cell 3 is according to Annex C.3.3, respectively. The CRS assistance information [7] includes Cell 2 and Cell3.

Table 8.2.1.3.4-1: Test Parameters for Large Delay CDD (FRC) – Non-MBSFN ABS

Parameter		Unit	Cell 1	Cell 2	Cell 3
Downlink power allocation	$\rho_A$	dB	-3	-3	-3
	$\rho_B$	dB	-3 (Note 1)	-3 (Note 1)	-3 (Note 1)
	$\sigma$	dB	0	N/A	N/A
$N_{oc}$ at antenna port	$N_{oc1}$	dBm/15kHz	-98 (Note 2)	N/A	N/A
	$N_{oc2}$	dBm/15kHz	-98 (Note 3)	N/A	N/A
	$N_{oc3}$	dBm/15kHz	-93 (Note 4)	N/A	N/A
$\hat{E}_s/N_{oc2}$	dB	Reference Value in Table 8.2.1.3.4-2	Reference Value in Table 8.2.1.3.4-2	Reference Value in Table 8.2.1.3.4-2	
$BW_{Channel}$	MHz	10	10	10	
Subframe Configuration			Non-MBSFN	Non-MBSFN	Non-MBSFN
Time Offset between Cells		$\mu$ s	N/A	3	-1
Frequency shift between Cells		Hz	N/A	300	-100
Cell Id			0	1	126
ABS pattern (Note 5)			N/A	11000000 11000000 11000000 11000000 11000000	11000000 11000000 11000000 11000000 11000000
RLM/RRM Measurement Subframe Pattern (Note 6)			10000000 10000000 10000000 10000000 10000000	N/A	N/A
CSI Subframe Sets (Note 7)	$C_{CSI,0}$		11000000 11000000 11000000 11000000 11000000	N/A	N/A
	$C_{CSI,1}$		00111111 00111111 00111111 00111111 00111111	N/A	N/A
Number of control OFDM symbols			2	Note 8	Note 8
PDSCH transmission mode			3	Note 9	Note 9
Cyclic prefix			Normal	Normal	Normal
<p>Note 1: <math>P_B = 1</math>.</p> <p>Note 2: This noise is applied in OFDM symbols #1, #2, #3, #5, #6, #8, #9, #10, #12, #13 of a subframe overlapping with the aggressor ABS.</p> <p>Note 3: This noise is applied in OFDM symbols #0, #4, #7, #11 of a subframe overlapping with the aggressor ABS.</p> <p>Note 4: This noise is applied in all OFDM symbols of a subframe overlapping with aggressor non-ABS</p> <p>Note 5: ABS pattern as defined in [9].</p> <p>Note 6: Time-domain measurement resource restriction pattern for PCell measurements as defined in [7]</p> <p>Note 7: As configured according to the time-domain measurement resource restriction pattern for CSI measurements defined in [7].</p> <p>Note 8: The number of control OFDM symbols is not available for ABS and is 2 for the subframe indicated by "0" of ABS pattern.</p> <p>Note 9: Downlink physical channel setup in Cell 2 and Cell 3 in accordance with Annex C.3.3 applying OCNG pattern as defined in Annex A.5.</p> <p>Note 10: The number of the CRS ports in Cell 1, Cell 2 and Cell 3 is the same.</p> <p>Note 11: SIB-1 will not be transmitted in Cell 2 and Cell 3 in this test.</p>					

Table 8.2.1.3.4-2: Minimum Performance Large Delay CDD (FRC) – Non-MBSFN ABS

Test Number	Reference Channel	$\bar{E}_s/N_{oc2}$		OCNG Pattern			Propagation Conditions (Note1)			Correlation Matrix and Antenna Configuration (Note 2)	Reference Value		UE Category
		Cell 2	Cell 3	Cell 1	Cell 2	Cell 3	Cell 1	Cell 2	Cell 3		Fraction of Maximum Throughput (%) Note 5	SNR (dB) (Note 3)	
1	R.11 FDD Note 4	9	7	OP.1 FDD	OP.1 FDD	OP.1 FDD	EVA5	EVA5	EVA5	2x2 Low	70	13.9	≥2
2	R.35 FDD Note 4	9	1	OP.1 FDD	OP.1 FDD	OP.1 FDD	EVA5	EVA5	EVA5	2x2 Low	70	22.6	≥2

Note 1: The propagation conditions for Cell 1, Cell 2 and Cell 3 are statistically independent.  
Note 2: The correlation matrix and antenna configuration apply for Cell 1, Cell 2 and Cell 3.  
Note 3: SNR corresponds to  $\bar{E}_s/N_{oc2}$  of cell 1.  
Note 4: Cell 1 Reference channel is modified: PDSCH other than SIB1/paging and its associated PDCCH/PCFICH are transmitted in the serving cell subframe when the subframe is overlapped with the ABS subframe of aggressor cell and the subframe is available in the definition of the reference channel.  
Note 5: The maximum Throughput is calculated from the total Payload in 9 subframes, averaged over 40ms.

### 8.2.1.3.5 Minimum Requirement 2 Tx Antenna Port (Superposed transmission)

The requirements are specified in Table 8.2.1.3.5-2, with the addition of the parameters in Table 8.2.1.3.5-1 and the downlink physical channel setup according to Annex C.3.2. The purpose is to verify the minimum performance of open-loop spatial multiplexing with 2 transmitter antennas superposed with simultaneous PDSCH interference.

Table 8.2.1.3.5-1: Test Parameters for Minimum Requirement 2 Tx Antenna Port - Superposed transmission (FRC)

Parameter	Unit	Test 1	
Downlink power allocation	$\rho_A$	dB	0
	$\rho_B$	dB	0 (NOTE 1)
	$\sigma$	dB	0
	PDSCH_RA	dB	-3
	PDSCH_RB	dB	-3
$N_{oc}$ at antenna port		dBm/15kHz	-98
PDSCH transmission mode			3
MUSTIdx (Note 2)			10
p-a-must-r14 (Note 3)			-3
Note 1: $P_B = 1$ .			
Note 2: MUSTIdx is described in subclause 6.3.3 of [4].			
Note 3: p-a-must-r14 is described in subclause 6.3.2 of [7].			

**Table 8.2.1.3.5-2: Minimum Performance for Minimum Requirement 2 Tx Antenna Port - Superposed transmission (FRC)**

Test number	Bandwidth	Reference Channel	OCNG Pattern	Propagation Condition	Correlation Matrix and Antenna Configuration	Reference value		UE Category
						Fraction of Maximum Throughput (%)	SNR (dB)	
1	10 MHz	R.bb FDD	OP.1 FDD	EVA5	2x2 Low	70	19.3	≥2

### 8.2.1.3.6 Minimum Requirement 2 Tx Antenna Port (network-based CRS interference mitigation)

The requirements are specified in Table 8.2.1.3.6-2, with the addition of parameters in Table 8.2.1.3.6-1 and the downlink physical channel setup according to Annex C.3.2. The purpose is to verify the performance of open-loop spatial multiplexing performance with 2 transmit antennas when the PDSCH transmission in the serving cell is interfered by CRS of one dominant interfering cell with network-based CRS interference mitigation. In Table 8.2.1.3.6-1, Cell 1 is the serving cell, and Cell 2 is interfering cell. The downlink physical channel setup is according to Annex C.3.2 for each of Cell 1 and Cell 2 respectively.

**Table 8.2.1.3.6-1: Test parameters for Larger Delay CDD (FRC) with network-based CRS interference mitigation**

Parameter	Unit	Cell 1	Cell 2
Bandwidth	MHz		10 MHz
Downlink power allocation	$\rho_A$	-3	0
	$\rho_B$	-3 (Note 1)	0
	$\sigma$	0	0
Cell-specific reference signals		Antenna ports 0,1	Antenna port 0,1
Cyclic Prefix		Normal	Normal
Cell ID		0	1
Transmission mode		3	NA (Note 4)
$N_{oc}$ at antenna port	dBm/15k Hz	-98	-98
$\tilde{E}_s/N_{oc}$ (Note 2)	dB	Reference Value in Table 8.2.1.3.6-2	10
Correlation and antenna configuration		Low (2x2)	Low (2x2)
Max number of HARQ transmissions		4	N/A
Redundancy version coding sequence		{0,1,2,3}	N/A
nw-BasedCRS-InterferenceMitigation-r15		Disabled	Enabled
CRS transmission		On	CRS is configured with CRS muting pattern as '0000001111111111000' where every 20 subframes consist of 11 subframes with full system BW CRS and 9 subframes with CRS only on the center 6 PRBs (Note 5)
Note 1: $\rho_B = 1$ Note 2: Cell 1 is the serving cell. Cell 2 is the interfering cell. Note 3: All cells are time-synchronous. Note 4: Cell 2 has no PDSCH/PDCCH configured Note 5: In the muting pattern '0000001111111111000', 1 indicates DL subframes with full system BW CRS configured and 0 indicates DL subframes with CRS only on the center 6 PRBs configured.			

**Table 8.2.1.3.6-2: Minimum performance Large Delay CDD (FRC) with network-based CRS interference mitigation**

Test Number	Reference Channel	OCNG Pattern		Propagation Conditions (Note 1)		Reference Value		UE Category
		Cell 1	Cell 2	Cell 1	Cell 2	Fraction of Maximum Throughput (%)	SNR (dB) (Note 2)	
1	R.11-13 FDD	OP.1 FDD	NA	EVA5	EVA5	70	15.1	≥2
Note 1: The propagation conditions for Cell 1 and Cell 2 are statistically independent.								
Note 2: SNR corresponds to $\bar{E}_s/N_{oc}$ of Cell 1.								

### 8.2.1.4 Closed-loop spatial multiplexing performance

#### 8.2.1.4.1 Minimum Requirement Single-Layer Spatial Multiplexing 2 Tx Antenna Port

The requirements are specified in Table 8.2.1.4.1-2, with the addition of the parameters in Table 8.2.1.4.1-1 and the downlink physical channel setup according to Annex C.3.2. The purpose of these tests is to verify the closed loop rank-one performance with wideband and frequency selective precoding.

**Table 8.2.1.4.1-1: Test Parameters for Single-Layer Spatial Multiplexing (FRC)**

Parameter	Unit	Test 1	Test 1A	Test 2
Downlink power allocation	$\rho_A$	dB	-3	-3
	$\rho_B$	dB	-3 (Note 1)	-3 (Note 1)
	$\sigma$	dB	0	0
$N_{oc}$ at antenna port	dBm/15kHz	-98	-98	-98
Precoding granularity	PRB	6	4	50
PMI delay (Note 2)	ms	8	8	8
Reporting interval	ms	1	1	1
Reporting mode		PUSCH 1-2	PUSCH 1-2	PUSCH 3-1
CodeBookSubsetRestriction bitmap		001111	001111	001111
PDSCH transmission mode		4	4	4
Note 1: $P_{\rho_B} = 1$ .				
Note 2: If the UE reports in an available uplink reporting instance at subframe SF#n based on PMI estimation at a downlink SF not later than SF#(n-4), this reported PMI cannot be applied at the eNB downlink before SF#(n+4).				

**Table 8.2.1.4.1-2: Minimum performance Single-Layer Spatial Multiplexing (FRC)**

Test number	Bandwidth	Reference Channel	OCNG Pattern	Propagation Condition	Correlation Matrix and Antenna Configuration	Reference value		UE Category
						Fraction of Maximum Throughput (%)	SNR (dB)	
1	10 MHz	R.10 FDD	OP.1 FDD	EVA5	2x2 Low	70	-2.5	≥1
1A (Note 1)	5 MHz	R.10-2 FDD	OP.1 FDD	EVA5	2x2 Low	70	-2.9	≥1
2	10 MHz	R.10 FDD	OP.1 FDD	EPA5	2x2 High	70	-2.3	≥1
Note 1: Test case applicability is defined in 8.1.2.1.								

8.2.1.4.1A Minimum Requirement Single-Layer Spatial Multiplexing 4 Tx Antenna Port

The requirements are specified in Table 8.2.1.4.1A-2, with the addition of the parameters in Table 8.2.1.4.1A-1 and the downlink physical channel setup according to Annex C.3.2. The purpose of these tests is to verify the closed loop rank-one performance with wideband and frequency selective precoding.

Table 8.2.1.4.1A-1: Test Parameters for Single-Layer Spatial Multiplexing (FRC)

Parameter	Unit	Test 1	Test 2
Downlink power allocation	$\rho_A$	-6	-6
	$\rho_B$	-6 (Note 1)	-6 (Note 1)
	$\sigma$	3	3
$N_{oc}$ at antenna port	dBm/15kHz	-98	-98
Precoding granularity	PRB	6	50
PMI delay (Note 2)	ms	8	8
Reporting interval	ms	1	1
Reporting mode		PUSCH 1-2	PUSCH 3-1
CodeBookSubsetRestriction on bitmap		0000000000000000 0000000000000000 0000000000000000 1111111111111111	0000000000000000 0000000000000000 0000000000000000 1111111111111111
PDSCH transmission mode		4	4
Note 1: $P_B = 1$ .			
Note 2: If the UE reports in an available uplink reporting instance at subframe SF#n based on PMI estimation at a downlink SF not later than SF#(n-4), this reported PMI cannot be applied at the eNB downlink before SF#(n+4).			

Table 8.2.1.4.1A-2: Minimum performance Single-Layer Spatial Multiplexing (FRC)

Test number	Bandwidth	Reference Channel	OCNG Pattern	Propagation Condition	Correlation Matrix and Antenna Configuration	Reference value		UE Category	UE DL category
						Fraction of Maximum Throughput (%)	SNR (dB)		
1	10 MHz	R.13 FDD	OP.1 FDD	EVA5	4x2 Low	70	-3.2	≥1	≥4
2	10MHz 1024QAM	R.101 FDD	OP.1 FDD	EPA5	4x2 Low	70	25.1	TBD	20, ≥ 22

8.2.1.4.1B Enhanced Performance Requirement Type A - Single-Layer Spatial Multiplexing 2 Tx Antenna Port with TM4 interference model

The requirements are specified in Table 8.2.1.4.1B-2, with the addition of the parameters in Table 8.2.1.4.1B-1 and the downlink physical channel setup according to Annex C.3.2. The purpose of these tests is to verify the closed loop rank-one performance with wideband precoding with two transmit antennas when the PDSCH transmission in the serving cell is interfered by PDSCH of two dominant interfering cells applying transmission mode 4 interference model defined in clause B.5.3. In Table 8.2.1.4.1B-1, Cell 1 is the serving cell, and Cell 2, 3 are interfering cells. The downlink physical channel setup is according to Annex C.3.2 for each of Cell 1, Cell 2 and Cell 3, respectively.

**Table 8.2.1.4.1B-1: Test Parameters for Single-Layer Spatial Multiplexing (FRC) with TM4 interference model**

Parameter		Unit	Cell 1	Cell 2	Cell 3
Downlink power allocation	$\rho_A$	dB	-3	-3	-3
	$\rho_B$	dB	-3 (Note 1)	-3	-3
	$\sigma$	dB	0	0	0
Cell-specific reference signals			Antenna ports 0,1	Antenna ports 0,1	Antenna ports 0,1
$N_{oc}$ at antenna port		dBm/15kHz	-98	N/A	N/A
DIP (Note 2)		dB	N/A	-1.73	-8.66
$BW_{\text{Channel}}$		MHz	10	10	10
Cyclic Prefix			Normal	Normal	Normal
Cell Id			0	1	2
Number of control OFDM symbols			2	2	2
PDSCH transmission mode			6	N/A	N/A
Interference model			N/A	As specified in clause B.5.3	As specified in clause B.5.3
Probability of occurrence of transmission rank in interfering cells	Rank 1	%	N/A	80	80
	Rank 2	%	N/A	20	20
Precoding granularity		PRB	50	6	6
PMI delay (Note 4)		ms	8	N/A	N/A
Reporting interval		ms	5	N/A	N/A
Reporting mode			PUCCH 1-1	N/A	N/A
CodeBookSubsetRestriction bitmap			1111	N/A	N/A
Physical channel for CQI reporting			PUSCH(Note 6)	N/A	N/A
cqi-pmi-ConfigurationIndex			2	N/A	N/A
<p>Note 1: <math>P_B = 1</math></p> <p>Note 2: The respective received power spectral density of each interfering cell relative to <math>N_{oc}</math> is defined by its associated DIP value as specified in clause B.5.1.</p> <p>Note 3: Cell 1 is the serving cell. Cell 2, 3 are the interfering cells.</p> <p>Note 4: If the UE reports in an available uplink reporting instance at subframe SF#n based on PMI estimation at a downlink SF not later than SF#(n-4), this reported PMI cannot be applied at the eNB downlink before SF#(n+4).</p> <p>Note 5: All cells are time-synchronous.</p> <p>Note 6: To avoid collisions between CQI reports and HARQ-ACK it is necessary to report both on PUSCH instead of PUCCH. PDCCH DCI format 0 shall be transmitted in downlink SF#1 and #6 to allow periodic CQI to multiplex with the HARQ-ACK on PUSCH in uplink subframe SF#5 and #0.</p>					



**Table 8.2.1.4.1B-2: Enhanced Performance Requirement Type A, Single-Layer Spatial Multiplexing (FRC) with TM4 interference model**

Test Number	Reference Channel	OCNG Pattern			Propagation Conditions			Correlation Matrix and Antenna Configuration (Note 3)	Reference Value		UE Category
		Cell 1	Cell 2	Cell 3	Cell 1	Cell 2	Cell 3		Fraction of Maximum Throughput (%)	SINR (dB) (Note 2)	
1	R.47 FDD	OP. 1 FDD	N/A	N/A	EV A5	EV A5	EV A5	2x2 Low	70	0.8	≥1
Note 1: The propagation conditions for Cell 1, Cell 2 and Cell 3 are statistically independent. Note 2: SINR corresponds to $E_s/N_{oc}$ of Cell 1 as defined in clause 8.1.1. Note 3: Correlation matrix and antenna configuration parameters apply for each of Cell 1, Cell 2 and Cell 3.											

**8.2.1.4.1C Minimum Requirement Single-Layer Spatial Multiplexing 2 Tx Antenna Ports (demodulation subframe overlaps with aggressor cell ABS and CRS assistance information are configured)**

The requirements are specified in Table 8.2.1.4.1C-2, with the addition of parameters in Table 8.2.1.4.1C-1. The purpose is to verify the closed loop rank-one performance with wideband precoding if the PDSCH transmission in the serving cell takes place in subframes that overlap with ABS [9] of the aggressor cell with CRS assistance information. In Table 8.2.1.4.1C-1, Cell 1 is the serving cell, and Cell 2 and Cell 3 are the aggressor cells. The downlink physical channel setup for Cell 1 is according to Annex C.3.2 and for Cell 2 and Cell 3 is according to Annex C.3.3, respectively. The CRS assistance information [7] includes Cell 2 and Cell 3.

**Table 8.2.1.4.1C-1: Test Parameters for Single-Layer Spatial Multiplexing (FRC) – Non-MBSFN ABS**

Parameter		Unit	Cell 1	Cell 2	Cell 3
Downlink power allocation	$\rho_A$	dB	-3	-3	-3
	$\rho_B$	dB	-3 (Note 1)	-3 (Note 1)	-3 (Note 1)
	$\sigma$	dB	0	N/A	N/A
$N_{oc}$ at antenna port	$N_{oc1}$	dBm/15kHz	-98 (Note 2)	N/A	N/A
	$N_{oc2}$	dBm/15kHz	-98 (Note 3)	N/A	N/A
	$N_{oc3}$	dBm/15kHz	-93 (Note 4)	N/A	N/A
$\hat{E}_s/N_{oc2}$		dB	Reference Value in Table 8.2.1.4.1C-2	12	10
BW <sub>Channel</sub>		MHz	10	10	10
Subframe Configuration			Non-MBSFN	Non-MBSFN	Non-MBSFN
Time Offset between Cells		$\mu$ s	N/A	3	-1
Frequency shift between Cells		Hz	N/A	300	-100
Cell Id			0	126	1
ABS pattern (Note 5)			N/A	11000000 11000000 11000000 11000000 11000000	11000000 11000000 11000000 11000000 11000000
RLM/RRM Measurement Subframe Pattern (Note 6)			10000000 10000000 10000000 10000000	N/A	N/A
CSI Subframe Sets (Note 7)	C <sub>CSI,0</sub>		11000000 11000000 11000000 11000000 11000000	N/A	N/A
	C <sub>CSI,1</sub>		00111111 00111111 00111111 00111111 00111111	N/A	N/A
Number of control OFDM symbols			2	Note 8	Note 8
PDSCH transmission mode			6	Note 9	Note 9
Precoding granularity		PRB	50	N/A	N/A
PMI delay (Note 10)		ms	8	N/A	N/A
Reporting interval		ms	1	N/A	N/A
Reporting mode			PUSCH 3-1	N/A	N/A
CodeBookSubsetRestriction bitmap			1111	N/A	N/A
Cyclic prefix			Normal	Normal	Normal

Note 1:	$P_B = 1$ .
Note 2:	This noise is applied in OFDM symbols #1, #2, #3, #5, #6, #8, #9, #10, #12, #13 of a subframe overlapping with the aggressor ABS.
Note 3:	This noise is applied in OFDM symbols #0, #4, #7, #11 of a subframe overlapping with the aggressor ABS.
Note 4:	This noise is applied in all OFDM symbols of a subframe overlapping with aggressor non-ABS
Note 5:	ABS pattern as defined in [9].
Note 6:	Time-domain measurement resource restriction pattern for PCell measurements as defined in [7]
Note 7:	As configured according to the time-domain measurement resource restriction pattern for CSI measurements defined in [7].
Note 8:	The number of control OFDM symbols is not available for ABS and is 2 for the subframe indicated by "0" of ABS pattern.
Note 9:	Downlink physical channel setup in Cell 2 and Cell 3 in accordance with Annex C.3.3 applying OCNG pattern as defined in Annex A.5.
Note 10:	If the UE reports in an available uplink reporting instance at subframe SF#n based on PMI estimation at a downlink SF not later than SF#(n-4), this reported PMI cannot be applied at the eNB downlink before SF#(n+4).
Note 11:	The number of the CRS ports in Cell 1, Cell 2 and Cell 3 is the same.
Note 12:	SIB-1 will not be transmitted in Cell 2 and Cell 3 in this test.

Table 8.2.1.4.1C-2: Minimum Performance Single-Layer Spatial Multiplexing (FRC)– Non-MBSFN ABS

Test Number	Reference Channel	OCNG Pattern			Propagation Conditions (Note1)			Correlation Matrix and Antenna Configuration (Note 2)	Reference Value		UE Category
		Cell 1	Cell 2	Cell 3	Cell 1	Cell 2	Cell 3		Fraction of Maximum Throughput (%) Note 5	SNR (dB) (Note 3)	
1	R.11 FDD Note 4	OP.1 FDD	OP.1 FDD	OP.1 FDD	EPA5	EPA5	EPA5	2x2 High	70	6.1	≥2
Note 1:	The propagation conditions for Cell 1, Cell 2 and Cell 3 are statistically independent.										
Note 2:	The correlation matrix and antenna configuration apply for Cell 1, Cell 2 and Cell 3.										
Note 3:	SNR corresponds to $\bar{E}_s/N_{\alpha_2}$ of cell 1.										
Note 4:	Cell 1 Reference channel is modified: PDSCH other than SIB1/paging and its associated PDCCH/PCFICH are transmitted in the serving cell subframe when the subframe is overlapped with the ABS subframe of aggressor cell and the subframe is available in the definition of the reference channel.										
Note 5:	The maximum Throughput is calculated from the total Payload in 9 subframes, averaged over 40ms.										

#### 8.2.1.4.1D Enhanced Performance Requirement Type B - Single-layer Spatial Multiplexing 2 Tx Antenna Port with TM4 interference model

The requirements are specified in Table 8.2.1.4.1D-2, with the addition of the parameters in Table 8.2.1.4.1D-1 and the downlink physical channel setup according to Annex C.3.2. The purpose of these tests is to verify the closed loop rank-one performance with wideband precoding with two transmit antennas when the PDSCH transmission in the serving cell is interfered by PDSCH of two interfering cells applying transmission mode 4 interference model defined in clause B.6.3. In Table 8.2.1.4.1D-1, Cell 1 is the serving cell, and Cell 2, 3 are interfering cells. The downlink physical channel setup is according to Annex C.3.2 for each of Cell 1, Cell 2 and Cell 3, respectively.

**Table 8.2.1.4.1D-1: Test Parameters for Single-layer Spatial Multiplexing (FRC) with TM4 interference model**

Parameter		Unit	Cell 1	Cell 2	Cell 3		
Downlink power allocation	$\rho_A$	dB	-3	-3	-3		
	$\rho_B$	dB	-3 (Note 1)	-3	-3		
	$\sigma$	dB	0	0	0		
Cell-specific reference signals			Antenna ports 0,1	Antenna ports 0,1	Antenna ports 0,1		
$N_{oc}$ at antenna port		dBm/15 kHz	-98				
Test number (Note 4)				Test 1	Test 2	Test 1	Test 2
$\bar{E}_s/N_{oc}$		dB	N/A	13.91	3.28	3.34	0.74
Cell Id				6	1	1	6
CFI indicated in PCFICH			3	Random from set {1,2,3}	3	Random from set {1,2,3}	
BW <sub>Channel</sub>		MHz	10	10	10		
Cyclic Prefix			Normal	Normal	Normal		
Number of control OFDM symbols			3	3	3		
PDSCH transmission mode			4	4	4		
Interference model			N/A	As specified in clause B.6.3	As specified in clause B.6.3		
Precoding			Random wideband precoding per TTI	As specified in clause B.6.3	As specified in clause B.6.3		
Time offset to cell 1		us	N/A	2	3		
Frequency offset to cell 1		Hz	N/A	200	300		
MBSFN			Not configured	Not configured	Not configured		
NeighCellsInfo-r12 (Note 3)	p-aList-r12		N/A	{dB-6, dB-3, dB0}	{dB-6, dB-3, dB0}		
	transmissionModeList-r12		N/A	{2,3,4,8,9}	{2,3,4,8,9}		
Note 1: $P_B = 1$							
Note 2: Cell 1 is the serving cell. Cell 2, 3 are the interfering cells.							
Note 3: NeighCellsInfo-r12 is described in subclause 6.3.2 of [7].							
Note 4: Test 1 and Test 2 are defined in Table 8.2.1.4.1D-2.							

**Table 8.2.1.4.1D-2: Minimum Performance for Enhanced Performance Requirement Type B, Single-layer Spatial Multiplexing (FRC) with TM4 interference model**

Test Num	Reference Channel	OCNG Pattern			Propagation Conditions			Correlation Matrix and Antenna Configuration (Note 3)	Reference Value		UE Category
		Cell 1	Cell 2	Cell 3	Cell 1	Cell 2	Cell 3		Fraction of Maximum Throughput (%)	SNR (dB) (Note 2)	
1	R.11-10 FDD	OP.1 FDD	N/A	N/A	EVA <sub>5</sub>	EVA <sub>5</sub>	EVA <sub>5</sub>	2x2 Low	85	17.0	≥1
2	R.11-9 FDD	OP.1 FDD	N/A	N/A	EPA <sub>5</sub>	EPA <sub>5</sub>	EPA <sub>5</sub>	2x2 Low	85	10.1	≥1
Note 1: The propagation conditions for Cell 1, Cell 2 and Cell 3 are statistically independent.											
Note 2: SNR corresponds to $E_s/N_{oc}$ of Cell 1 as defined in clause 8.1.1.											
Note 3: Correlation matrix and antenna configuration parameters apply for each of Cell 1, Cell 2 and Cell 3.											

### 8.2.1.4.1E Minimum Requirement Single-Layer Spatial Multiplexing 2 Tx Antenna Ports with CRS assistance information

The requirements are specified in Table 8.2.1.4.1E-2, with the addition of parameters in Table 8.2.1.4.1E-1. The purpose is to verify the closed loop rank-one performance with wideband precoding when CRS assistance information [7] is configured. In Table 8.2.1.4.1E-1, Cell 1 is the serving cell, and Cell 2 and Cell 3 are the aggressor cells. The downlink physical channel setup is according to Annex C.3.2 for each of Cell 1, Cell 2 and Cell 3, respectively. The CRS assistance information [7] includes Cell 2 and Cell 3.

**Table 8.2.1.4.1E-1: Test Parameters for Single-Layer Spatial Multiplexing (FRC)**

Parameter		Unit	Cell 1	Cell 2	Cell 3
Downlink power allocation	$\rho_A$	dB	-3	-3	-3
	$\rho_B$	dB	-3 (Note 1)	-3 (Note 1)	-3 (Note 1)
	$\sigma$	dB	0	0	0
$N_{oc}$ at antenna port		dBm/15kHz	-98	N/A	N/A
$\tilde{E}_s/N_{oc}$		dB	Reference Value in Table 8.2.1.4.1E-2	10.45	4.6
BW <sub>Channel</sub>		MHz	10	10	10
Subframe Configuration			Non-MBSFN	Non-MBSFN	Non-MBSFN
Time Offset to Cell 1		$\mu$ s	N/A	3	-1
Frequency shift to Cell 1		Hz	N/A	300	-100
Cell Id			0	1	128
Cell-specific reference signals			Antenna ports 0,1		
Number of control OFDM symbols			2	2	2
PDSCH transmission mode			4	N/A	N/A
Precoding granularity		PRB	50	N/A	N/A
PMI delay (Note 2)		ms	8	N/A	N/A
Reporting interval		ms	1	N/A	N/A
Reporting mode			PUSCH 3-1	N/A	N/A
CodeBookSubsetRestriction bitmap			001111	N/A	N/A
Cyclic prefix			Normal	Normal	Normal
Interference model			N/A	As specified in clause B.5.3	As specified in clause B.5.3
Probability of occurrence of transmission in interference cells		%	N/A	20	20
Probability of occurrence of transmission rank in interfering cells	Rank 1	%	N/A	80	80
	Rank 2	%	N/A	20	20
Note 1: $P_B = 1$ .					
Note 2: If the UE reports in an available uplink reporting instance at subframe SF#n based on PMI estimation at a downlink SF not later than SF#(n-4), this reported PMI cannot be applied at the eNB downlink before SF#(n+4).					

**Table 8.2.1.4.1E-2: Minimum Performance Single-Layer Spatial Multiplexing (FRC)**

Test Number	Reference Channel	OCNG Pattern			Propagation Conditions (Note1)			Correlation Matrix and Antenna Configuration (Note 2)	Reference Value		UE Category
		Cell 1	Cell 2	Cell 3	Cell 1	Cell 2	Cell 3		Fraction of Maximum Throughput (%)	SNR (dB) (Note 3)	

1	R.10-3 FDD	OP.1 FDD	N/A	N/A	EVA5	EVA5	EVA5	2x2 low	70	10.8	≥2
Note 1: The propagation conditions for Cell 1, Cell 2 and Cell 3 are statistically independent.											
Note 2: The correlation matrix and antenna configuration apply for Cell 1, Cell 2 and Cell 3.											
Note 3: SNR corresponds to $\bar{E}_s/N_{oc}$ of cell 1.											

#### 8.2.1.4.1F Minimum Requirement Single-Layer Spatial Multiplexing 4 Tx Antenna Ports with CRS assistance information

The requirements are specified in Table 8.2.1.4.1F-2, with the addition of parameters in Table 8.2.1.4.1F-1. In Table 8.2.1.4.1F-1, Cell 1 is the serving cell, and Cell 2 and Cell 3 are the aggressor cells. The downlink physical channel setup is according to Annex C.3.2 for each of Cell 1, Cell 2 and Cell 3, respectively. The CRS assistance information [7] is provided to the UE and includes information on Cell 2 and Cell 3.

The purpose of the test is to verify the closed loop single layer TM4 performance under assumption that UE applies CRS interference mitigation in the scenario with 4 CRS antenna ports in the serving and aggressor cells.

**Table 8.2.1.4.1F-1: Test Parameters**

Parameter		Unit	Cell 1	Cell 2	Cell 3
Downlink power allocation	$\rho_A$	dB	-6	-6	-6
	$\rho_B$	dB	-6 (Note 1)	-6 (Note 1)	-6 (Note 1)
	$\sigma$	dB	3	3	3
$N_{oc}$ at antenna port		dBm/15kHz	-98	N/A	N/A
$\bar{E}_s/N_{oc}$		dB	Reference Value in Table 8.2.1.4.1F-2	10.45	4.6
$BW_{channel}$		MHz	10	10	10
Cyclic prefix			Normal	Normal	Normal
Subframe Configuration			Non-MBSFN	Non-MBSFN	Non-MBSFN
Cell ID			0	1	6
Cell-specific reference signals			Antenna ports 0,1,2,3		
Number of control OFDM symbols (CFI)			2	2	2
PDSCH transmission mode			4	N/A	N/A
Precoding granularity		PRB	50	N/A	N/A
PMI delay (Note 2)		ms	8	N/A	N/A
Reporting interval		ms	1	N/A	N/A
Reporting mode			PUSCH 3-1	N/A	N/A
CodeBookSubsetRestriction bitmap			000000000000 FFFF	N/A	N/A
Time Offset relative to Cell 1		μs	N/A	3	-1
Frequency shift relative to Cell 1		Hz	N/A	300	-100
Interference model			N/A	As specified in clause B.5.3	As specified in clause B.5.3
Probability of occurrence of transmission in interference cells		%	N/A	20	20
Probability of occurrence of transmission rank in interfering cells	Rank 1	%	N/A	80	80
	Rank 2	%	N/A	20	20
Note 1: $P_B = 1$ .					
Note 2: If the UE reports in an available uplink reporting instance at subframe SF #n based on PMI estimation at a downlink SF not later than SF #(n-4), this reported PMI cannot be applied at the eNB downlink before SF #(n+4).					

Table 8.2.1.4.1F-2: Minimum Performance for PDSCH

Test Number	Reference Channel	OCNG Pattern			Propagation Conditions (Note1)			Correlation Matrix and Antenna Configuration (Note 2)	Reference Value		UE Category
		Cell 1	Cell 2	Cell 3	Cell 1	Cell 2	Cell 3		Fraction of Maximum Throughput (%)	SNR (dB) (Note 3)	
1	R.36 FDD	OP.1 FDD	N/A	N/A	EVA5	EVA5	EVA5	4x2 low	70	14.0	≥2

Note 1: The propagation conditions for Cell 1, Cell 2 and Cell 3 are statistically independent.  
Note 2: The correlation matrix and antenna configuration apply for Cell 1, Cell 2 and Cell 3.  
Note 3: SNR corresponds to  $E_s/N_{oc}$  of cell 1.

## 8.2.1.4.2 Minimum Requirement Multi-Layer Spatial Multiplexing 2 Tx Antenna Port

The requirements are specified in Table 8.2.1.4.2-2, with the addition of the parameters in Table 8.2.1.4.2-1 and the downlink physical channel setup according to Annex C.3.2. The purpose of these tests is to verify the closed loop rank-two performance with wideband and frequency selective precoding.

Table 8.2.1.4.2-1: Test Parameters for Multi-Layer Spatial Multiplexing (FRC)

Parameter	Unit	Test 1-2	Test 2A	Test 3	
Downlink power allocation	$\rho_A$	dB	-3	-3	-3
	$\rho_B$	dB	-3 (Note 1)	-3 (Note 1)	-3 (Note 1)
	$\sigma$	dB	0	0	0
$N_{oc}$ at antenna port	dBm/15kHz	-98	-98	-98	
Precoding granularity	PRB	50	25	6	
PMI delay (Note 2)	ms	8	8	8	
Reporting interval	ms	1	1	1	
Reporting mode		PUSCH 3-1	PUSCH 3-1	PUSCH 1-2	
CodeBookSubsetRestriction bitmap		110000	110000	110000	
PDSCH transmission mode		4	4	4	
Number of OFDM symbols for PDCCH per component carrier	OFDM symbol	2	3	1	

Note 1:  $P_B = 1$ .  
Note 2: If the UE reports in an available uplink reporting instance at subframe SF#n based on PMI estimation at a downlink SF not later than SF#(n-4), this reported PMI cannot be applied at the eNB downlink before SF#(n+4).

Table 8.2.1.4.2-2: Minimum performance Multi-Layer Spatial Multiplexing (FRC)

Test number	Bandwidth	Reference Channel	OCNG Pattern	Propagation Condition	Correlation Matrix and Antenna Configuration	Reference value		UE Category	UE DL category
						Fraction of Maximum Throughput (%)	SNR (dB)		
1	10 MHz	R.35 FDD	OP.1 FDD	EPA5	2x2 Low	70	18.9	≥2	≥6
2	10 MHz	R.11 FDD	OP.1 FDD	ETU70	2x2 Low	70	14.3	≥2	≥6
2A (Note 1)	5 MHz	R.11-2 FDD	OP.1 FDD	ETU70	2x2 Low	70	14.0	≥2	≥6
3	10MHz 256QAM	R. 65 FDD	OP.1 FDD	EVA5	2x2 Low	70	25.3	11-12	≥11

Note 1: Test case applicability is defined in 8.1.2.1.



### 8.2.1.4.2A Enhanced Performance Requirement Type C – Multi-layer Spatial Multiplexing 2Tx Antenna Ports

The requirements are specified in Table 8.2.1.4.2A-2, with the addition of the parameters in Table 8.2.1.4.2A-1 and the downlink physical channel setup according to Annex C.3.2. The purpose of these tests is to verify the closed loop rank-two performance with wideband precoding.

**Table 8.2.1.4.2A-1: Test Parameters for Multi-Layer Spatial Multiplexing (FRC)**

Parameter	Unit	Test 1	
Downlink power allocation	$\rho_A$	dB	-3
	$\rho_B$	dB	-3 (Note 1)
	$\sigma$	dB	0
$N_{oc}$ at antenna port	dBm/15kHz	-98	
Precoding granularity	PRB	50	
PMI delay (Note 2)	ms	8	
Reporting interval	ms	1	
Reporting mode		PUSCH 3-1	
CodeBookSubsetRestriction bitmap		110000	
PDSCH transmission mode		4	
Note 1: $P_B = 1$ .			
Note 2: If the UE reports in an available uplink reporting instance at subframe SF#n based on PMI estimation at a downlink SF not later than SF#(n-4), this reported PMI cannot be applied at the eNB downlink before SF#(n+4).			

**Table 8.2.1.4.2A-2: Enhanced Performance Requirement Type C for Multi-Layer Spatial Multiplexing with TM4 (FRC)**

Test number	Bandwidth	Reference Channel	OCNG Pattern	Propagation Condition	Correlation Matrix and Antenna Configuration	Reference value		UE Category
						Fraction of Maximum Throughput (%)	SNR (dB)	
1	10 MHz	R.11 FDD	OP.1 FDD	ETU70	2x2 Medium	70	18.3	$\geq 2$

### 8.2.1.4.3 Minimum Requirement Multi-Layer Spatial Multiplexing 4 Tx Antenna Port

For single carrier, the requirements are specified in Table 8.2.1.4.3-2, with the addition of the parameters in Table 8.2.1.4.3-1 and the downlink physical channel setup according to Annex C.3.2.

For CA with 2 DL CCs, the requirements are specified in Table 8.2.1.4.3-4, with the addition of the parameters in Table 8.2.1.4.3-3 and the downlink physical channel setup according to Annex C.3.2. The purpose of these tests is to verify the closed loop rank-two performance with wideband and frequency selective precoding.

For CA with 3 DL CCs, the requirements are specified in Table 8.2.1.4.3-6, based on single carrier requirement specified in Table 8.2.1.4.3-5, with the addition of the parameters in Table 8.2.1.4.3-3 and the downlink physical channel setup according to Annex C.3.2.

For CA with 4 DL CCs, the requirements are specified in Table 8.2.1.4.3-7, based on single carrier requirement specified in Table 8.2.1.4.3-5, with the addition of the parameters in Table 8.2.1.4.3-3 and the downlink physical channel setup according to Annex C.3.2.

For CA with 5 DL CCs, the requirements are specified in Table 8.2.1.4.3-8, based on single carrier requirement specified in Table 8.2.1.4.3-5, with the addition of the parameters in Table 8.2.1.4.3-3 and the downlink physical channel setup according to Annex C.3.2.

For CA with 6 DL CCs, the requirements are specified in Table 8.2.1.4.3-9, based on single carrier requirement specified in Table 8.2.1.4.3-5, with the addition of the parameters in Table 8.2.1.4.3-3 and the downlink physical channel setup according to Annex C.3.2.

For CA with 7 DL CCs, the requirements are specified in Table 8.2.1.4.3-10, based on single carrier requirement specified in Table 8.2.1.4.3-5, with the addition of the parameters in Table 8.2.1.4.3-3 and the downlink physical channel setup according to Annex C.3.2.

The test coverage for different number of component carriers is defined in 8.1.2.4.

**Table 8.2.1.4.3-1: Test Parameters for Multi-Layer Spatial Multiplexing (FRC)**

Parameter		Unit	Test 1
Downlink power allocation	$\rho_A$	dB	-6
	$\rho_B$	dB	-6 (Note 1)
	$\sigma$	dB	3
$N_{oc}$ at antenna port		dBm/15kHz	-98
Precoding granularity		PRB	6
PMI delay (Note 2)		ms	8
Reporting interval		ms	1
Reporting mode			PUSCH 1-2
CodeBookSubsetRestriction bitmap			00000000000000000000000000000000 00001111111111111111111100000000 00000000
PDSCH transmission mode			4
Note 1: $P_B = 1$ .			
Note 2: If the UE reports in an available uplink reporting instance at subframe SF#n based on PMI estimation at a downlink SF not later than SF#(n-4), this reported PMI cannot be applied at the eNB downlink before SF#(n+4).			
Note 3: Void.			
Note 4: Void.			
Note 5: Void.			

**Table 8.2.1.4.3-2: Minimum performance Multi-Layer Spatial Multiplexing (FRC)**

Test num.	Bandwidth	Referenc echannel	OCNG pattern	Propa- gation condi- tion	Correlation matrix and antenna config.	Reference value		UE cate- gory
						Fraction of maximum throughput (%)	SNR (dB)	
1	10 MHz	R.36 FDD	OP.1 FDD	EPA5	4x2 Low	70	14.7	$\geq 2$
Note 1: Void.								

Table 8.2.1.4.3-3: Test Parameters for Multi-Layer Spatial Multiplexing (FRC) for CA

Parameter	Unit	Value	
Downlink power allocation	$\rho_A$	dB	-6
	$\rho_B$	dB	-6 (Note 1)
	$\sigma$	dB	3
$N_{oc}$ at antenna port	dBm/15kHz	-98	
Precoding granularity	PRB	4 for 3MHz and 5MHz CCs, 6 for 10MHz CCs, 8 for 15MHz and 20MHz CCs	
PMI delay (Note 2)	ms	8	
Reporting interval	ms	1	
Reporting mode		PUSCH 1-2	
CodeBookSubsetRestriction bitmap		00000000000000000000000000000000 0011111111111111111111000000000000 0000	
CSI request field (Note 3)		'10'	
PDSCH transmission mode		4	
Note 1: $P_B = 1$ .			
Note 2: If the UE reports in an available uplink reporting instance at subframe SF#n based on PMI estimation at a downlink SF not later than SF#(n-4), this reported PMI cannot be applied at the eNB downlink before SF#(n+4).			
Note 3: Multiple CC-s under test are configured as the 1 <sup>st</sup> set of serving cells by higher layers.			
Note 4: ACK/NACK bits are transmitted using PUSCH with PUCCH format 1b with channel selection configured for Tests in Table 8.2.1.4.3-4, and with PUCCH format 3 for Tests in Table 8.2.1.4.3-6.			
Note 5: The same PDSCH transmission mode is applied to each component carrier.			

Table 8.2.1.4.3-4: Minimum performance Multi-Layer Spatial Multiplexing (FRC) for CA with 2DL CCs

Test num	Bandwidth	Reference channel	OCNG pattern	Propagation condition	Correlation matrix and antenna config.	Reference value		UE category
						Fraction of maximum throughput (%)	SNR (dB)	
1	2x10 MHz	R.14 FDD	OP.1 FDD (Note 1)	EVA5	4x2 Low	70	10.8	≥3
2	2x20 MHz	R.14-3 FDD	OP.1 FDD (Note 1)	EVA5	4x2 Low	70	10.9	≥5
3	2x5 MHz	R.14-6 FDD	OP.1 FDD (Note 1)	EVA5	4x2 Low	70	9.5	≥2
			OP.1 FDD (Note 1)			70	9.5	
4	10MHz+5 MHz	R.14 FDD for 10MHz CC	OP.1 FDD (Note 1)	EVA5	4x2 Low	70	10.1	≥3
		R.14-6 FDD for 5MHz CC	OP.1 FDD (Note 1)			70	9.5	
5	15MHz+5 MHz	R.14-7 FDD for 15MHz CC	OP.1 FDD (Note 1)	EVA5	4x2 Low	70	10.1	≥3
		R.14-6 FDD for 5MHz CC	OP.1 FDD (Note 1)			70	9.5	
NOTE 1: The OCNG pattern applies for each CC.								
NOTE 2: The applicability of requirements for different CA configurations and bandwidth combination sets is defined in 8.1.2.3.								

Table 8.2.1.4.3-5: Single carrier performance for multiple CA configurations

Band-width	Reference channel	OCNG pattern	Propa-gation condi-tion	Correlation matrix and antenna config.	Reference value	
					Fraction of maximum throughput (%)	SNR (dB)
1.4MHz	R.14-4 FDD	OP.1 FDD	EVA5	4x2 Low	70	10.4
3MHz	R.14-5 FDD	OP.1 FDD	EVA5	4x2 Low	70	9.5
5MHz	R.14-6 FDD	OP.1 FDD	EVA5	4x2 Low	70	9.5
10 MHz	R.14 FDD	OP.1 FDD	EVA5	4x2 Low	70	10.1
15MHz	R.14-7 FDD	OP.1 FDD	EVA5	4x2 Low	70	10.1
20MHz	R.14-3 FDD	OP.1 FDD	EVA5	4x2 Low	70	10.3

Table 8.2.1.4.3-6: Minimum performance (FRC) based on single carrier performance for CA with 3 DL CCs

Test num.	CA Band-width combination	Requirement	UE category
1	3x20MHz	As specified in Table 8.2.1.4.3-5 per CC	≥5
2	20MHz+20MHz+15MHz	As specified in Table 8.2.1.4.3-5 per CC	≥5
3	20MHz+20MHz+10MHz	As specified in Table 8.2.1.4.3-5 per CC	≥5
4	20MHz+15MHz+15MHz	As specified in Table 8.2.1.4.3-5 per CC	≥5
5	20MHz+15MHz+10MHz	As specified in Table 8.2.1.4.3-5 per CC	≥5
6	20MHz+10MHz+10MHz	As specified in Table 8.2.1.4.3-5 per CC	≥5
7	15MHz+15MHz+10MHz	As specified in Table 8.2.1.4.3-5 per CC	≥5
8	20MHz+10MHz+5MHz	As specified in Table 8.2.1.4.3-5 per CC	≥5
9	20MHz+15MHz+5MHz	As specified in Table 8.2.1.4.3-5 per CC	≥5
10	10MHz+10MHz+5MHz	As specified in Table 8.2.1.4.3-5 per CC	≥5
11	5MHz+5MHz+20MHz	As specified in Table 8.2.1.4.3-5 per CC	≥5
12	3x10MHz	As specified in Table 8.2.1.4.3-5 per CC	≥5
13	5MHz+5MHz+10MHz	As specified in Table 8.2.1.4.3-5 per CC	≥5

Note 1: The applicability of requirements for different CA configurations and bandwidth combination sets is defined in 8.1.2.3

Table 8.2.1.4.3-7: Minimum performance (FRC) based on single carrier performance for CA with 4 DL CCs

Test num.	CA Band-width combination	Requirement	UE category
1	4x20MHz	As specified in Table 8.2.1.4.3-5 per CC	≥8
2	10MHz+20MHz+20MHz+20MHz	As specified in Table 8.2.1.4.3-5 per CC	≥8
3	10MHz+10MHz+20MHz+20MHz	As specified in Table 8.2.1.4.3-5 per CC	≥8
4	5MHz+10MHz+20MHz+20MHz	As specified in Table 8.2.1.4.3-5 per CC	≥8
5	5MHz+10MHz+10MHz+20MHz	As specified in Table 8.2.1.4.3-5 per CC	≥8
6	15+3x20MHz	As specified in Table 8.2.1.3.1-5 per CC	≥8
7	2x15+2x20MHz	As specified in Table 8.2.1.3.1-5 per CC	≥8
8	10+15+2x20MHz	As specified in Table 8.2.1.3.1-5 per CC	≥8
9	3x10+20MHz	As specified in Table 8.2.1.3.1-5 per CC	≥8
10	2x5+2x20MHz	As specified in Table 8.2.1.3.1-5 per CC	≥8
11	2x5+10+20MHz	As specified in Table 8.2.1.3.1-5 per CC	≥8
12	4x10MHz	As specified in Table 8.2.1.3.1-5 per CC	≥8

NOTE 1: The applicability of requirements for different CA configurations and bandwidth combination sets is defined in 8.1.2.3

**Table 8.2.1.4.3-8: Minimum performance (FRC) based on single carrier performance for CA with 5 DL CCs**

Test num.	CA Band-width combination	Requirement	UE category
1	5x20MHz	As specified in Table 8.2.1.4.3-5 per CC	8, ≥11
2	15MHz+4x20MHz	As specified in Table 8.2.1.4.3-5 per CC	8, ≥11
3	10MHz+4x20MHz	As specified in Table 8.2.1.4.3-5 per CC	8, ≥11
4	2x10MHz+3x20MHz	As specified in Table 8.2.1.4.3-5 per CC	8, ≥11
5	5MHz+10MHz+3x20MHz	As specified in Table 8.2.1.4.3-5 per CC	8, ≥11
6	3x10MHz+2x20MHz	As specified in Table 8.2.1.4.3-5 per CC	8, ≥11
7	4x10MHz+20MHz	As specified in Table 8.2.1.4.3-5 per CC	8, ≥11
NOTE 1: The applicability of requirements for different CA configurations and bandwidth combination sets is defined in 8.1.2.3			

**Table 8.2.1.4.3-9: Minimum performance (FRC) based on single carrier performance for CA with 6 DL CCs**

Test num.	CA Band-width combination	Requirement	UE category
1	6x20MHz	As specified in Table 8.2.1.4.3-5 per CC	8, ≥11
NOTE 1: The applicability of requirements for different CA configurations and bandwidth combination sets is defined in 8.1.2.3			

**Table 8.2.1.4.3-10: Minimum performance (FRC) based on single carrier performance for CA with 7 DL CCs**

Test num.	CA Band-width combination	Requirement	UE category
1	7x20MHz	As specified in Table 8.2.1.4.3-5 per CC	8, ≥11
NOTE 1: The applicability of requirements for different CA configurations and bandwidth combination sets is defined in 8.1.2.3			

#### 8.2.1.4.3A Minimum Requirement Multi-Layer Spatial Multiplexing 4 Tx Antenna Port for dual connectivity

For dual connectivity the requirements are specified in Table 8.2.1.4.3A-3 for 2DL CCs and Table 8.2.1.4.3A-4 for 3DL CCs, based on single carrier requirement specified in Table 8.2.1.4.3A-2, with the addition of the parameters in Table 8.2.1.4.3A-1 and the downlink physical channel setup according to Annex C.3.2. The purpose of these tests is to verify the closed loop rank-two performance with wideband and frequency selective precoding by using dual connectivity transmission.

Table 8.2.1.4.3A-1: Test Parameters for Multi-Layer Spatial Multiplexing (FRC) for dual connectivity

Parameter	Unit	Values	
Downlink power allocation	$\rho_A$	dB	-6
	$\rho_B$	dB	-6 (Note 1)
	$\sigma$	dB	3
$N_{oc}$ at antenna port	dBm/15kHz	-98	
Precoding granularity	PRB	6 for 1.4MHz, 4 for 3MHz and 5MHz CCs, 6 for 10MHz CCs, and 8 for 15MHz CCs and 20MHz CCs	
PMI delay (Note 2)	ms	8	
Reporting interval	ms	1	
Reporting mode		PUSCH 1-2	
CodeBookSubsetRestriction bitmap		00000000000000000000000000000000 00001111111111111111100000000 00000000	
PDSCH transmission mode		4	
ACK/NACK transmission		Separate ACK/NACK feedbacks with PUCCH format 1b on the MCG and SCG	
CSI feedback		Separate PUSCH feedbacks on the MCG and SCG	
Time offset between MCG CC and SCG CC	$\mu$ s	0 for UE under test supporting synchronous dual connectivity; 334 for UE under test supporting both asynchronous and synchronous dual connectivity (Note 4)	
<p>Note 1: <math>P_B = 1</math>.</p> <p>Note 2: If the UE reports in an available uplink reporting instance at subframe SF#n based on PMI estimation at a downlink SF not later than SF#(n-4), this reported PMI cannot be applied at the eNB downlink before SF#(n+4).</p> <p>Note 3: The same PDSCH transmission mode is applied to each component carrier.</p> <p>Note 4: As defined in TS36.300 [11].</p> <p>Note 5: If the UE supports both SCG bearer and Split bearer, the SCG bearer is configured.</p>			

Table 8.2.1.4.3A-2: Single carrier performance for multiple dual connectivity configurations

Bandwidth	Reference channel	OCNG pattern	Propagation condition	Correlation matrix and antenna config.	Reference value	
					Fraction of maximum throughput (%)	SNR (dB)
1.4MHz	R.14-4 FDD	OP. 1 FDD	EVA5	4x2 Low	70	10.36
3MHz	R.14-5 FDD	OP. 1 FDD	EVA5	4x2 Low	70	9.5
5MHz	R.14-6 FDD	OP. 1 FDD	EVA5	4x2 Low	70	9.5
10 MHz	R.14 FDD	OP. 1 FDD	EVA5	4x2 Low	70	10.1
15MHz	R.14-7 FDD	OP. 1 FDD	EVA5	4x2 Low	70	10.1
20MHz	R.14-3 FDD	OP. 1 FDD	EVA5	4x2 Low	70	10.3

**Table 8.2.1.4.3A-3: Minimum performance Multi-Layer Spatial Multiplexing (FRC) for dual connectivity with 2 DL CCs**

Test num.	Band-width combination	Requirement	UE category
1	2x20 MHz	As specified in Table 8.2.1.4.3A-2 per CC	≥5
2	15+20 MHz	As specified in Table 8.2.1.4.3A-2 per CC	≥5
3	10+20MHz	As specified in Table 8.2.1.4.3A-2 per CC	≥5
4	2x15 MHz	As specified in Table 8.2.1.4.3A-2 per CC	≥5
5	2x10 MHz	As specified in Table 8.2.1.4.3A-2 per CC	≥3
6	15+5 MHz	As specified in Table 8.2.1.4.3A-2 per CC	≥3
7	10+15 MHz	As specified in Table 8.2.1.4.3A-2 per CC	≥5
Note 1: The OCNG pattern applies for each CC.			
Note 2: The applicability of requirements for different dual connectivity configurations and bandwidth combination sets is defined in 8.1.2.3A.			

**Table 8.2.1.4.3A-4: Minimum performance Multi-Layer Spatial Multiplexing (FRC) for dual connectivity with 3DL CCs**

Test num.	Band-width combination	Requirement	UE category
1	20+20+15MHz	As specified in Table 8.2.1.4.3A-2 per CC	≥5
2	20+15+15MHz	As specified in Table 8.2.1.4.3A-2 per CC	≥5
3	3x20 MHz	As specified in Table 8.2.1.4.3A-2 per CC	≥5
4	20+20+10 MHz	As specified in Table 8.2.1.4.3A-2 per CC	≥5
5	20+15+10 MHz	As specified in Table 8.2.1.4.3A-2 per CC	≥5
6	20+10+10 MHz	As specified in Table 8.2.1.4.3A-2 per CC	≥5
7	15+15+10 MHz	As specified in Table 8.2.1.4.3A-2 per CC	≥5
Note 1: The OCNG pattern applies for each CC.			
Note 2: The applicability of requirements for different dual connectivity configurations and bandwidth combination sets is defined in 8.1.2.3A.			

#### 8.2.1.4.4 Minimum Requirement Multi-Layer Spatial Multiplexing 2 Tx Antenna Port (Superposed transmission)

The requirements are specified in Table 8.2.1.4.4-2, with the addition of the parameters in Table 8.2.1.4.4-1 and the downlink physical channel setup according to Annex C.3.2. The purpose is to verify the minimum performance of closed-loop spatial multiplexing with 2 transmitter antennas superposed with simultaneous PDSCH interference.

**Table 8.2.1.4.4-1: Test Parameters for Minimum Requirement Multi-Layer Spatial Multiplexing 2 Tx Antenna Port - Superposed transmission (FRC)**

Parameter	Unit	Test 1	
Downlink power allocation	$\rho_A$	dB	0
	$\rho_B$	dB	0 (NOTE 1)
	$\sigma$	dB	0
	PDSCH_RA	dB	-3
	PDSCH_RB	dB	-3
$N_{oc}$ at antenna port		dBm/15kHz	-98
PDSCH transmission mode			4
Precoding			Random wideband precoding per TTI
MUSTIdx for transport block 1 (Note 2)			10
MUSTIdx for transport block 2 (Note 2)			00
p-a-must-r14 (Note 3)			-3
Note 1: $P_B = 1$ .			
Note 2: MUSTIdx is described in subclause 6.3.3 of [4].			
Note 3: p-a-must-r14 is described in subclause 6.3.2 of [7].			

**Table 8.2.1.4.4-2: Minimum Performance for Minimum Requirement Multi-Layer Spatial Multiplexing 2 Tx Antenna Port - Superposed transmission (FRC)**

Test number	Bandwidth	Reference Channel	OCNG Pattern	Propagation Condition	Correlation Matrix and Antenna Configuration	Reference value		UE Category
						Fraction of Maximum Throughput (%)	SNR (dB)	
1	10 MHz	R.bb FDD	OP.1 FDD	EVA5	2x2 Low	70	17.3	$\geq 2$

### 8.2.1.5 MU-MIMO

### 8.2.1.6 [Control channel performance: D-BCH and PCH]

### 8.2.1.7 Carrier aggregation with power imbalance

For CA, the requirements in this section verify the ability of an intraband adjacent carrier aggregation UE to demodulate the signal transmitted by the PCell or SCell in the presence of a stronger SCell or PCell signal on an adjacent frequency. Throughput is measured on the PCell or SCell only.

#### 8.2.1.7.1 Minimum Requirement

The requirements are specified in Table 8.2.1.7.1-2, with the addition of the parameters in Table 8.2.1.7.1-1 and the downlink physical channel setup according to Annex C.3.2.



Table 8.2.1.7.1-1: Test Parameters for CA

Parameter	Unit	Test 1	Test 2-3
Downlink power allocation	$\rho_A$	dB	0
	$\rho_B$	dB	0 (Note 1)
	$\sigma$	dB	0
$N_{oc}$ at antenna port	dBm/15kHz	Off (Note 2)	Off (Note 2)
Symbols for unused PRBs		OCNG (Note 3)	OCNG (Note 3)
Modulation		64 QAM	64 QAM
Maximum number of HARQ transmission		1	1
Redundancy version coding sequence		{0}	{0}
PDSCH transmission mode of PCell		1	3
PDSCH transmission mode of SCell		3	1
OCNG Pattern	PCell	OP.1 FDD	OP.5 FDD
	SCell	OP.5 FDD	OP.1 FDD
Propagation Conditions	PCell	Clause B.1	Clause B.1
	SCell	Clause B.1	Clause B.1
Correlation Matrix and Antenna	PCell	1x2	2x2
	SCell	2x2	1x2
Note 1: $P_B = 0$ for 1x2 and $P_B = 1$ for 2x2 antenna configuration.			
Note 2: No external noise sources are applied			
Note 3: These physical resource blocks are assigned to an arbitrary number of virtual UEs with one PDSCH per virtual UE; the data transmitted over the OCNG PDSCHs shall be uncorrelated. pseudo random data.			
Note 4: Void			

Table 8.2.1.7.1-2: Minimum performance (FRC) for CA

Test Number	Bandwidth (MHz)		Reference channel		Power at antenna port (dBm/15KHz)		Reference value Fraction of Maximum Throughput (%)		UE Category
	PCell	SCell	PCell	SCell	$\hat{E}_{s\_PCell}$ for PCell	$\hat{E}_{s\_SCell}$ for SCell	PCell	SCell	
1	20	20	R.49 FDD	NA	-85	-79	85	NA	$\geq 5$
2	10	10	NA	R.49-1 FDD	-79	-85.8	NA	85	$\geq 5$
3	5	5	NA	R.49-2 FDD	-79	-85.9	NA	85	$\geq 5$
Note 1:	The OCNG pattern for PCell is used to fill the control channel. The OCNG pattern for SCell is used to fill the control channel and PDSCH.								
Note 2:	The applicability of requirements for different CA configurations and bandwidth combination sets is defined in 8.1.2.3.								

### 8.2.1.8 Intra-band non-contiguous carrier aggregation with timing offset

The requirements in this section verify the ability of an intraband non-contiguous carrier aggregation UE to demodulate the signal transmitted by the PCell and SCell in the presence of timing offset between the cells. Throughput is measured on both cells.

#### 8.2.1.8.1 Minimum Requirement

For CA the requirements are specified in Table 8.2.1.8.1-2, with the addition of the parameters in Table 8.2.1.8.1-1 and the downlink physical channel setup according to Annex C.3.2.

Table 8.2.1.8.1-1: Test Parameters for CA

Parameter	Unit	Test 1	
Downlink power allocation	$\rho_A$	dB	-3
	$\rho_B$	dB	-3 (Note 1)
	$\sigma$	dB	0
$N_{oc}$ at antenna port	dBm/15kHz	-98	
Modulation		64 QAM	
Maximum number of HARQ transmission		4	
Redundancy version coding sequence		{0,0,1,2}	
PDSCH transmission mode of PCell		3	
PDSCH transmission mode of SCell		3	
Note 1: $P_B = 1$ .			
Note 2: The OCNG pattern is used to fill unused control channel and PDSCH.			

Table 8.2.1.8.1-2: Minimum performance (FRC) for CA

Test Number	Cell	Bandwidth	Reference Channel	OCNG Pattern	Propagation Conditions	Correlation Matrix and Antenna	Reference value		Timing relative to PCell ( $\mu$ s)	UE Category
							Fraction of Maximum Throughput (%)	SNR (dB)		
1	PCell	10MHz	R.35-4 FDD	OP.1 FDD	EPA200	2x2 Low	70	21.15	N/A	$\geq 3$
	SCell	10MHz	R.35-3 FDD		EPA200	2x2 Low	60	15.18	-30.26	
Note 1: The EPA200 propagation channels applied to PCell and SCell are statistically independent.										
Note 2: The applicability and test rules of requirements for different CA configurations and bandwidth combination sets are defined in 8.1.2.3.										

## 8.2.1.9 HST-SFN performance

### 8.2.1.9.1 Minimum Requirement

The purpose of this test is to verify UE performance in the HST-SFN scenario defined in B.3A when *highSpeedEnhancedDemodulationFlag* [7] is received.

For single carrier, the requirements are specified in Table 8.2.1.9.1-2, with the addition of the parameters in Table 8.2.1.9.1-1 and the downlink physical channel setup according to Annex C.3.2.

For CA with 2 DL CC, the requirements are specified in Table 8.2.1.9.1-5, based on single carrier requirement specified in Table 8.2.1.9.1-4, with the addition of the parameters in Table 8.2.1.9.1-3 and the downlink physical channel setup according to Annex C.3.2.

For CA with 3 DL CCs, the requirements are specified in Table 8.2.1.9.1-6, based on single carrier requirement specified in Table 8.2.1.9.1-4, with the addition of the parameters in Table 8.2.1.9.1-3 and the downlink physical channel setup according to Annex C.3.2.

For CA with 4 DL CCs, the requirements are specified in Table 8.2.1.9.1-7, based on single carrier requirement specified in Table 8.2.1.9.1-4, with the addition of the parameters in Table 8.2.1.9.1-3 and the downlink physical channel setup according to Annex C.3.2.

For CA with 5 DL CCs, the requirements are specified in Table 8.2.1.9.1-8, based on single carrier requirement specified in Table 8.2.1.9.1-4, with the addition of the parameters in Table 8.2.1.9.1-3 and the downlink physical channel setup according to Annex C.3.2.

The test coverage for different number of component carriers is defined in 8.1.2.4.

**Table 8.2.1.9.1-1: Test Parameters for UE performance in HST-SFN scenario (FRC)**

Parameter	Unit	Test 1	
Downlink power allocation	$\rho_A$	dB	-3
	$\rho_B$	dB	-3 (NOTE 1)
	$\sigma$	dB	0
$N_{oc}$ at antenna port		dBm/15kHz	-98
PDSCH transmission mode			3
NOTE 1: $P_B = 1$ .			

**Table 8.2.1.9.1-2: Minimum performance UE in HST-SFN scenario (FRC)**

Test number	Bandwidth	Reference Channel	OCNG Pattern	Propagation Condition	Correlation Matrix and Antenna Configuration	Reference value		UE Category
						Fraction of Maximum Throughput (%)	SNR (dB)	
1	10 MHz	R.87 FDD	OP.1 FDD	HST-SFN	2x2	70	13.3	$\geq 1$
NOTE 1: The requirement defined is based on the normalized channel model, i.e. the power of each tap is normalized to the instantaneous total received power from four taps.								

**Table 8.2.1.9.1-3: Test Parameters for Large Delay CDD (FRC) for CA**

Parameter	Unit	Value
Downlink power allocation	$\rho_A$	dB
	$\rho_B$	dB
	$\sigma$	dB
$N_{oc}$ at antenna port	dBm/15kHz	-98
PDSCH transmission mode		3
NOTE 1: $P_B = 1$ .		
NOTE 2: PUCCH format 1b with channel selection is used to feedback ACK/NACK for Tests in Table 8.2.1.3.1-4, PUCCH format 3 is used to feedback ACK/NACK for Tests in Table 8.2.1.3.1-6.		
NOTE 3: The same PDSCH transmission mode is applied to each component carrier.		

**Table 8.2.1.9.1-4: Single carrier performance for multiple CA configurations**

Bandwidth	Reference channel	OCNG pattern	Propagation condition	Correlation matrix and antenna config.	Reference value	
					Fraction of maximum throughput (%)	SNR (dB)
5 MHz	R.87-2 FDD	OP. 1 FDD	HST-SFN	2x2 Low	70	[13.9]
10 MHz	R.87 FDD	OP. 1 FDD	HST-SFN	2x2 Low	70	[13.3]
15 MHz	R.87-3 FDD	OP. 1 FDD	HST-SFN	2x2 Low	70	[13.9]
20 MHz	R.87-4 FDD	OP. 1 FDD	HST-SFN	2x2 Low	70	[14.1]

Table 8.2.1.9.1-5: Minimum performance Large Delay CDD (FRC) for CA with 2DL CCs

Test num.	CA Band-width combination	Requirement	UE category
1	2x10MHz	As specified in Table 8.2.1.9.1-4 per CC	≥5
2	2x20MHz	As specified in Table 8.2.1.9.1-4 per CC	≥5
3	2x5MHz	As specified in Table 8.2.1.9.1-4 per CC	≥5
4	10MHz+5MHz	As specified in Table 8.2.1.9.1-4 per CC	≥5
5	15MHz+5MHz	As specified in Table 8.2.1.9.1-4 per CC	≥5

Table 8.2.1.9.1-6: Minimum performance (FRC) based on single carrier performance for CA with 3 DL CCs

Test num.	CA Band-width combination	Requirement	UE category
1	3x20MHz	As specified in Table 8.2.1.9.1-4 per CC	≥5
2	20MHz+20MHz+15MHz	As specified in Table 8.2.1.9.1-4 per CC	≥5
3	20MHz+20MHz+10MHz	As specified in Table 8.2.1.9.1-4 per CC	≥5
4	20MHz+15MHz+15MHz	As specified in Table 8.2.1.9.1-4 per CC	≥5
5	20MHz+15MHz+10MHz	As specified in Table 8.2.1.9.1-4 per CC	≥5
6	20MHz+10MHz+10MHz	As specified in Table 8.2.1.9.1-4 per CC	≥5
7	15MHz+15MHz+10MHz	As specified in Table 8.2.1.9.1-4 per CC	≥5
8	20MHz+10MHz+5MHz	As specified in Table 8.2.1.9.1-4 per CC	≥5
9	20MHz+15MHz+5MHz	As specified in Table 8.2.1.9.1-4 per CC	≥5
10	10MHz+10MHz+5MHz	As specified in Table 8.2.1.9.1-4 per CC	≥5
11	5MHz+5MHz+20MHz	As specified in Table 8.2.1.9.1-4 per CC	≥5
12	3x10MHz	As specified in Table 8.2.1.9.1-4 per CC	≥5
13	5MHz+5MHz+10MHz	As specified in Table 8.2.1.9.1-4 per CC	≥5

NOTE: The applicability of requirements for different CA configurations and bandwidth combination sets is defined in clause 8.1.2.3

Table 8.2.1.9.1-7: Minimum performance (FRC) based on single carrier performance for CA with 4 DL CCs

Test num.	CA Band-width combination	Requirement	UE category
1	4x20MHz	As specified in Table 8.2.1.9.1-4 per CC	≥8
2	10MHz+20MHz+20MHz+20MHz	As specified in Table 8.2.1.9.1-4 per CC	≥8
3	10MHz+10MHz+20MHz+20MHz	As specified in Table 8.2.1.9.1-4 per CC	≥8
4	5MHz+10MHz+20MHz+20MHz	As specified in Table 8.2.1.9.1-4 per CC	≥8
5	5MHz+10MHz+10MHz+20MHz	As specified in Table 8.2.1.9.1-4 per CC	≥8
6	15+3x20MHz	As specified in Table 8.2.1.9.1-4 per CC	≥8
7	2x15+2x20MHz	As specified in Table 8.2.1.9.1-4 per CC	≥8
8	10+15+2x20MHz	As specified in Table 8.2.1.9.1-4 per CC	≥8
9	3x10+20MHz	As specified in Table 8.2.1.9.1-4 per CC	≥8
10	2x5+2x20MHz	As specified in Table 8.2.1.9.1-4 per CC	≥8
11	2x5+10+20MHz	As specified in Table 8.2.1.9.1-4 per CC	≥8
12	4x10MHz	As specified in Table 8.2.1.9.1-4 per CC	≥8

NOTE: The applicability of requirements for different CA configurations and bandwidth combination sets is defined in clause 8.1.2.3

**Table 8.2.1.9.1-8: Minimum performance (FRC) based on single carrier performance for CA with 5 DL CCs**

Test num.	CA Band-width combination	Requirement	UE category
1	5x20MHz	As specified in Table 8.2.1.9.1-4 per CC	8, ≥11
2	15MHz+4x20MHz	As specified in Table 8.2.1.9.1-4 per CC	8, ≥11
3	10MHz+4x20MHz	As specified in Table 8.2.1.9.1-4 per CC	8, ≥11
4	2x10MHz+3x20MHz	As specified in Table 8.2.1.9.1-4 per CC	8, ≥11
5	5MHz+10MHz+3x20MHz	As specified in Table 8.2.1.9.1-4 per CC	8, ≥11
6	3x10MHz+2x20MHz	As specified in Table 8.2.1.9.1-4 per CC	8, ≥11
7	4x10MHz+20MHz	As specified in Table 8.2.1.9.1-4 per CC	8, ≥11
NOTE: The applicability of requirements for different CA configurations and bandwidth combination sets is defined in clause 8.1.2.3			

**8.2.1.9.2 Minimum Requirement for Rel-16 further enhanced HST**

The requirements are specified in Table 8.2.1.9.2-2, with the addition of the parameters in Table 8.2.1.9.2-1 and the downlink physical channel setup according to Annex C.3.2. The purpose of these tests is to verify UE performance in the HST-SFN-500 and HST-500 scenario. The test for HST-SFN-500 scenario defined in B.3B is applied when *highSpeedEnhDemodFlag2-r16* [7] is received. The test for HST-500 scenario defined in B.3C is applied when *highSpeedEnhDemodFlag2-r16* [7] is not received. HST-500 test is not applicable to UE that has passed HST-SFN-500 test.

**Table 8.2.1.9.2-1: Test Parameters for UE performance in HST-SFN-500 and HST-500 scenario (FRC)**

Parameter	Unit	Test 1
Downlink power allocation	$\rho_A$	dB -3
	$\rho_B$	dB -3 (NOTE 1)
	$\sigma$	dB 0
$N_{oc}$ at antenna port		dBm/15kHz -98
PDSCH transmission mode		3
NOTE 1: $P_B = 1$ .		

**Table 8.2.1.9.2-2: Minimum performance UE in HST-SFN-500 and HST-500 scenario (FRC)**

Test number	Band-width	Reference Channel	OCNG Pattern	Propagation Condition	Correlation Matrix and Antenna Configuration	Reference value		UE Category
						Fraction of Maximum Throughput (%)	SNR (dB)	
1 NOTE 2	10 MHz	R.87-1 FDD	OP.1 FDD	HST-SFN-500	2x2	70	9.7	≥ 1
2	10 MHz	R.87 FDD	OP.1 FDD	HST-500	2x2	70	11.4	≥ 1

NOTE 1: Test case applicability is defined in 8.1.2.6.

NOTE 2: The requirement defined is based on the normalized channel model, i.e. the power of each tap is normalized to the instantaneous total received power from four taps.

**8.2.1.10 Intra-band contiguous carrier aggregation with minimum channel spacing**

The requirements in this section verify the ability of an UE supporting intra-band contiguous carrier aggregation with minimum channel spacing to demodulate the signal transmitted by the PCell and SCell(s). Throughput is measured on each cell. The minimum channel spacing of intra-band contiguous carrier aggregation refers to the possible minimum channel spacing as any multiple of 300 kHz less than the nominal channel spacing defined in 5.7.1A.

### 8.2.1.10.1 Minimum Requirement

For CA the requirements are specified in Table 8.2.1.10.1-2, with the addition of the parameters in Table 8.2.1.10.1-1 and the downlink physical channel setup according to Annex C.3.2.

**Table 8.2.1.10.1-1: Test Parameters for CA**

Parameter		Unit	Test 1-2
Downlink power allocation	$\rho_A$	dB	0
	$\rho_B$	dB	0 (Note 1)
	$\sigma$	dB	0
$N_{oc}$ at antenna port		dBm/15kHz	-98
Symbols for unused PRBs			OCNG (Note 2)
Modulation			64QAM
ACK/NACK feedback mode			PUCCH format 1b with channel selection
PDSCH transmission mode			1
Note 1: $P_B = 0$			
Note 2: These physical resource blocks are assigned to an arbitrary number of virtual UEs with one PDSCH per virtual UE; the data transmitted over the OCNG PDSCHe shall be uncorrelated pseudo random data, which is QPSK modulated.			
Note 3: The same PDSCH transmission mode is applied to each component carrier.			

**Table 8.2.1.10.1-2: Single carrier performance for multiple CA configurations with minimum channel spacing**

Bandwidth	Reference channel	OCNG pattern	Propagation condition	Correlation matrix and antenna config.	Reference value	
					Fraction of maximum throughput (%)	SNR (dB)
5MHz	R.6 FDD	OP.1 FDD	EVA5	1x2 Low	70	17.4
10MHz	R.7 FDD	OP.1 FDD	EVA5	1x2 Low	70	17.7
15MHz	R.8 FDD	OP.1 FDD	EVA5	1x2 Low	70	17.7
20MHz	R.9 FDD	OP.1 FDD	EVA5	1x2 Low	70	17.6

**Table 8.2.1.10.1-3: Minimum performance (FRC) for intra-band CA with minimum channel spacing for CA with 2DL CCs**

Test num.	CA Band-width combination	Requirement	UE category
1	20MHz+20MHz	As specified in Table 8.2.1.10.1-2 per CC	$\geq 5$
2	20MHz+15MHz	As specified in Table 8.2.1.10.1-2 per CC	$\geq 5$
3	20MHz+10MHz	As specified in Table 8.2.1.10.1-2 per CC	$\geq 5$
4	20MHz+5MHz	As specified in Table 8.2.1.10.1-2 per CC	$\geq 5$
5	15MHz+15MHz	As specified in Table 8.2.1.10.1-2 per CC	$\geq 5$
6	10MHz+10MHz	As specified in Table 8.2.1.10.1-2 per CC	$\geq 5$
7	5MHz+10MHz	As specified in Table 8.2.1.10.1-2 per CC	$\geq 5$
Note 1: The applicability and test rules of requirements for different CA configurations and bandwidth combination sets are defined in 8.1.2.3.			

### 8.2.2 TDD (Fixed Reference Channel)

The parameters specified in Table 8.2.2-1 are valid for all TDD tests unless otherwise stated.

Table 8.2.2-1: Common Test Parameters (TDD)

Parameter	Unit	Value
Uplink downlink configuration (Note 1)		1
Special subframe configuration (Note 2)		4
Cyclic prefix		Normal
Cell ID		0
Inter-TTI Distance		1
Number of HARQ processes per component carrier	Processes	7
Maximum number of HARQ transmission		4
Redundancy version coding sequence		{0,1,2,3} for QPSK and 16QAM {0,0,1,2} for 64QAM, 256QAM and 1024QAM
Number of OFDM symbols for PDCCH per component carrier	OFDM symbols	4 for 1.4 MHz bandwidth, 3 for 3 MHz and 5 MHz bandwidths, 2 for 10 MHz, 15 MHz and 20 MHz bandwidths unless otherwise stated
Cross carrier scheduling		Not configured
Note 1:	as specified in Table 4.2-2 in TS 36.211 [4].	
Note 2:	as specified in Table 4.2-1 in TS 36.211 [4].	

### 8.2.2.1 Single-antenna port performance

The single-antenna performance in a given multi-path fading environments is determined by the SNR for which a certain relative information bit throughput of the reference measurement channels in Annex A.3.4 is achieved. The purpose of these tests is to verify the single-antenna performance with different channel models and MCS. The QPSK and 64QAM cases are also used to verify the performance for all bandwidths specified in Table 5.6.1-1.

#### 8.2.2.1.1 Minimum Requirement

For single carrier, the requirements are specified in Table 8.2.2.1.1-2, with the addition of the parameters in Table 8.2.2.1.1-1 and the downlink physical channel setup according to Annex C.3.2.

For CA with 2 DL CCs, the requirements are specified in Table 8.2.2.1.1-4, with the addition of the parameters in Table 8.2.2.1.1-3 and the downlink physical channel setup according to Annex C.3.2.

For CA with 3 DL CCs, the requirements are specified in Table 8.2.2.1.1-7, based on single carrier requirement specified in Table 8.2.2.1.1-5, with the addition of the parameters in Table 8.2.2.1.1-3 and the downlink physical channel setup according to Annex C.3.2.

For CA with 4 DL CCs, the requirements are specified in Table 8.2.2.1.1-8, based on single carrier requirement specified in Table 8.2.2.1.1-5, with the addition of the parameters in Table 8.2.2.1.1-3 and the downlink physical channel setup according to Annex C.3.2.

For CA with 5 DL CCs, the requirements are specified in Table 8.2.1.1.1-9, based on single carrier requirement specified in Table 8.2.2.1.1-5, with the addition of the parameters in Table 8.2.2.1.1-3 and the downlink physical channel setup according to Annex C.3.2.

For CA with 6 DL CCs, the requirements are specified in Table 8.2.1.1.1-10, based on single carrier requirement specified in Table 8.2.2.1.1-5, with the addition of the parameters in Table 8.2.2.1.1-3 and the downlink physical channel setup according to Annex C.3.2.

For CA with 7 DL CCs, the requirements are specified in Table 8.2.1.1.1-11, based on single carrier requirement specified in Table 8.2.2.1.1-5, with the addition of the parameters in Table 8.2.2.1.1-3 and the downlink physical channel setup according to Annex C.3.2.

The test coverage for different number of component carriers is defined in 8.1.2.4.

**Table 8.2.2.1.1-1: Test Parameters**

Parameter	Unit	Test 1- 5	Test 6- 8	Test 9- 15	Test 16- 18	Test 19	
Downlink power allocation	$\rho_A$	dB	0	0	0	0	0
	$\rho_B$	dB	0 (Note 1)	0 (Note 1)	0 (Note 1)	0 (Note 1)	0 (Note 1)
	$\sigma$	dB	0	0	0	0	0
$N_{oc}$ at antenna port	dBm/15kHz	-98	-98	-98	-98	-98	
Symbols for unused PRBs		OCNG (Note 2)	OCNG (Note 2)	OCNG (Note 2)	OCNG (Note 2)	OCNG (Note 2)	
Modulation		QPSK	16QAM	64QAM	16QAM	QPSK	
ACK/NACK feedback mode		Multiplexing	Multiplexin g	Multiplexin g	Multiplexin g	Multiplexin g	
PDSCH transmission mode		1	1	1	1	1	
Note 1: $P_B = 0$ Note 2: These physical resource blocks are assigned to an arbitrary number of virtual UEs with one PDSCH per virtual UE; the data transmitted over the OCNG PDSCHs shall be uncorrelated pseudo random data, which is QPSK modulated. Note 3: Void Note 4: Void							



Table 8.2.2.1.1-2: Minimum performance (FRC)

Test number	Bandwidth	Reference Channel	OCNG Pattern	Propagation Condition	Correlation Matrix and Antenna Configuration	Reference value		UE Category
						Fraction of Maximum Throughput (%)	SNR (dB)	
1	10 MHz	R.2 TDD	OP.1 TDD	EVA5	1x2 Low	70	-1.2	≥1
2	10 MHz	R.2 TDD	OP.1 TDD	ETU70	1x2 Low	70	-0.6	≥1
3	10 MHz	R.2 TDD	OP.1 TDD	ETU300	1x2 Low	70	-0.2	≥1
4	10 MHz	R.2 TDD	OP.1 TDD	HST	1x2	70	-2.6	≥1
5	1.4 MHz	R.4 TDD	OP.1 TDD	EVA5	1x2 Low	70	0.0	≥1
6	10 MHz	R.3 TDD	OP.1 TDD	EVA5	1x2 Low	70	6.7	≥2
	5 MHz	R.3-1 TDD	OP.1 TDD	EVA5	1x2 Low	70	6.7	1
7	10 MHz	R.3 TDD	OP.1 TDD	ETU70	1x2 Low	30	1.4	≥2
	5 MHz	R.3-1 TDD	OP.1 TDD	ETU70	1x2 Low	30	1.4	1
8	10 MHz	R.3 TDD	OP.1 TDD	ETU300	1x2 High	70	9.3	≥2
	5 MHz	R.3-1 TDD	OP.1 TDD	ETU300	1x2 High	70	9.3	1
9	3 MHz	R.5 TDD	OP.1 TDD	EVA5	1x2 Low	70	17.6	≥1
10	5 MHz	R.6 TDD	OP.1 TDD	EVA5	1x2 Low	70	17.6	≥2
	5 MHz	R.6-1 TDD	OP.1 TDD	EVA5	1x2 Low	70	17.6	1
11	10 MHz	R.7 TDD	OP.1 TDD	EVA5	1x2 Low	70	17.6	≥2
	10 MHz	R.7-1 TDD	OP.1 TDD	EVA5	1x2 Low	70	17.6	1
12	10 MHz	R.7 TDD	OP.1 TDD	ETU70	1x2 Low	70	19.1	≥2
	10 MHz	R.7-1 TDD	OP.1 TDD	ETU70	1x2 Low	70	19.1	1
13	10 MHz	R.7 TDD	OP.1 TDD	EVA5	1x2 High	70	19.1	≥2
	10 MHz	R.7-1 TDD	OP.1 TDD	EVA5	1x2 High	70	19.1	1
14	15 MHz	R.8 TDD	OP.1 TDD	EVA5	1x2 Low	70	17.8	≥2
	15 MHz	R.8-1 TDD	OP.1 TDD	EVA5	1x2 Low	70	17.8	1
15	20 MHz	R.9 TDD	OP.1 TDD	EVA5	1x2 Low	70	17.7	≥3
	20 MHz	R.9-2 TDD	OP.1 TDD	EVA5	1x2 Low	70	17.7	2
	20 MHz	R.9-1 TDD	OP.1 TDD	EVA5	1x2 Low	70	17.7	1
16	3 MHz	R.0 TDD	OP.1 TDD	ETU70	1x2 Low	30	2.1	≥1
17	10 MHz	R.1 TDD	OP.1 TDD	ETU70	1x2 Low	30	2.0	≥1
18	20 MHz	R.1 TDD	OP.1 TDD	ETU70	1x2 Low	30	2.1	≥1
19	10 MHz	R.41 TDD	OP.1 TDD	EVA5	1x2 Low	70	-5.3	≥1

Note 1: Void.

Table 8.2.2.1.1-3: Test Parameters for CA

ETSI

Parameter		Unit	Value
Downlink power allocation	$\rho_A$	dB	0
	$\rho_B$	dB	0 (Note 1)
	$\sigma$	dB	0
$N_{oc}$ at antenna port		dBm/15kHz	-98
Symbols for unused PRBs			OCNG (Note 2)
Modulation			QPSK
ACK/NACK feedback mode			PUCCH format 1b with channel selection for Tests in Table 8.2.2.1.1-4; PUCCH format 3 for Tests in Table 8.2.2.1.1-7
PDSCH transmission mode			1
Note 1: $P_B = 0$			
Note 2: These physical resource blocks are assigned to an arbitrary number of virtual UEs with one PDSCH per virtual UE; the data transmitted over the OCNG PDSCHs shall be uncorrelated pseudo random data, which is QPSK modulated.			
Note 3: The same PDSCH transmission mode is applied to each component carrier.			

Table 8.2.2.1.1-4: Minimum performance (FRC) for CA with 2DL CCs

Test number	Bandwidth	Reference Channel	OCNG Pattern	Propagation Condition	Correlation Matrix and Antenna Configuration	Reference value		UE Category
						Fraction of Maximum Throughput (%)	SNR (dB)	
1	2x20MHz	R.42 TDD	OP.1 TDD (Note 1)	EVA5	1x2 Low	70	-1.2	≥5
2	20MHz+15MHz	R.42 TDD for 20MHz CC	OP.1 TDD (Note 1)	EVA5	1x2 Low	70	-1.4	≥5
		R.42-3 TDD for 15MHz CC	OP.1 TDD (Note 1)			70	-1.4	
Note 1: The OCNG pattern applies for each CC.								
Note 2: The applicability of requirements for different CA configurations and bandwidth combination sets is defined in 8.1.2.3.								
Note 3: 30usec timing difference between PCell and any SCell is applied in inter-band CA case, where PCell can be assigned on any CC.								

Table 8.2.2.1.1-5: Single carrier performance for multiple CA configurations

Bandwidth	Reference channel	OCNG pattern	Propagation condition	Correlation matrix and antenna config.	Reference value	
					Fraction of maximum throughput (%)	SNR (dB)
1.4MHz	R.4 TDD	OP.1 TDD	EVA5	1x2 Low	70	-0.6
3MHz	R.42-1 TDD	OP.1 TDD	EVA5	1x2 Low	70	-0.8
5MHz	R.42-2 TDD	OP.1 TDD	EVA5	1x2 Low	70	-1.2
10MHz	R.2 TDD	OP.1 TDD	EVA5	1x2 Low	70	-1.6
15MHz	R.42-3 TDD	OP.1 TDD	EVA5	1x2 Low	70	-1.4
20MHz	R.42 TDD	OP.1 TDD	EVA5	1x2 Low	70	-1.4

Table 8.2.2.1.1-6: Void

**Table 8.2.2.1.1-7: Minimum performance (FRC) based on single carrier performance for CA with 3 DL CCs**

Test num.	CA Band-width combination	Requirement	UE category
1	3x20MHz	As specified in Table 8.2.2.1.1-5 per CC	≥5
2	20MHz+20MHz+15MHz	As specified in Table 8.2.2.1.1-5 per CC	≥5
Note 1: The applicability of requirements for different CA configurations and bandwidth combination sets is defined in 8.1.2.3			
Note 2: 30usec timing difference between PCell and any SCell is applied in inter-band CA case, where PCell can be assigned on any CC.			

**Table 8.2.2.1.1-8: Minimum performance (FRC) based on single carrier performance for CA with 4 DL CCs**

Test num.	CA Band-width combination	Requirement	UE category
1	4x20MHz	As specified in Table 8.2.2.1.1-5 per CC	≥8
2	20MHz+20MHz+20MHz+15MHz	As specified in Table 8.2.2.1.1-5 per CC	≥8
Note 1: The applicability of requirements for different CA configurations and bandwidth combination sets is defined in 8.1.2.3			

**Table 8.2.2.1.1-9: Minimum performance (FRC) based on single carrier performance for CA with 5 DL CCs**

Test num.	CA Band-width combination	Requirement	UE category
1	5x20MHz	As specified in Table 8.2.2.1.1-5 per CC	8, ≥11
2	15MHz+4x20MHz	As specified in Table 8.2.2.1.1-5 per CC	8, ≥11
Note 1: The applicability of requirements for different CA configurations and bandwidth combination sets is defined in 8.1.2.3			

**Table 8.2.2.1.1-10: Minimum performance (FRC) based on single carrier performance for CA with 6 DL CCs**

Test num.	CA Band-width combination	Requirement	UE category
1	6x20MHz	As specified in Table 8.2.2.1.1-5 per CC	8, ≥11
Note 1: The applicability of requirements for different CA configurations and bandwidth combination sets is defined in 8.1.2.3			

**Table 8.2.2.1.1-11: Minimum performance (FRC) based on single carrier performance for CA with 7 DL CCs**

Test num.	CA Band-width combination	Requirement	UE category
1	7x20MHz	As specified in Table 8.2.2.1.1-5 per CC	8, ≥11
Note 1: The applicability of requirements for different CA configurations and bandwidth combination sets is defined in 8.1.2.3			

8.2.2.1.2 Void

8.2.2.1.3 Void

8.2.2.1.4 Minimum Requirement 1 PRB allocation in presence of MBSFN

The requirements are specified in Table 8.2.2.1.4-2, with the addition of the parameters in Table 8.2.2.1.4-1 and the downlink physical channel setup according to Annex C.3.2. The purpose of these tests is to verify the single-antenna performance with a single PRB allocated at the lower band edge in presence of MBSFN.

**Table 8.2.2.1.4-1: Test Parameters for Testing 1 PRB allocation**

Parameter	Unit	Test 1
Downlink power allocation	$\rho_A$	dB 0
	$\rho_B$	dB 0 (Note 1)
	$\sigma$	dB 0
$N_{oc}$ at antenna port		dBm/15kHz -98
Symbols for MBSFN portion of MBSFN subframes (Note 2)		OCNG (Note 3)
ACK/NACK feedback mode		Multiplexing
PDSCH transmission mode		1
Note 1: $P_B = 0$ Note 2: The MBSFN portion of an MBSFN subframe comprises the whole MBSFN subframe except the first two symbols in the first slot. Note 3: The MBSFN portion of the MBSFN subframes shall contain QPSK modulated data. Cell-specific reference signals are not inserted in the MBSFN portion of the MBSFN subframes, QPSK modulated MBSFN data is used instead.		

**Table 8.2.2.1.4-2: Minimum performance 1PRB (FRC)**

Test number	Bandwidth	Reference Channel	OCNG Pattern	Propagation Condition	Correlation Matrix and Antenna Configuration	Reference value		UE Category
						Fraction of Maximum Throughput (%)	SNR (dB)	
1	10 MHz	R.29 TDD	OP.3 TDD	ETU70	1x2 Low	30	2.0	$\geq 1$

8.2.2.2 Transmit diversity performance

8.2.2.2.1 Minimum Requirement 2 Tx Antenna Port

The requirements are specified in Table 8.2.2.2.1-2, with the addition of the parameters in Table 8.2.2.2.1-1 and the downlink physical channel setup according to Annex C.3.2. The purpose is to verify the performance of transmit diversity (SFBC) with 2 transmitter antennas.

**Table 8.2.2.2.1-1: Test Parameters for Transmit diversity Performance (FRC)**

Parameter	Unit	Test 1-2
Downlink power allocation	$\rho_A$	dB
	$\rho_B$	dB
	$\sigma$	dB
$N_{oc}$ at antenna port		dBm/15kHz
ACK/NACK feedback mode		Multiplexing
PDSCH transmission mode		2
Note 1: $P_B = 1$		

**Table 8.2.2.2.1-2: Minimum performance Transmit Diversity (FRC)**

Test number	Bandwidth	Reference Channel	OCNG Pattern	Propagation Condition	Correlation Matrix and Antenna Configuration	Reference value		UE Category
						Fraction of Maximum Throughput (%)	SNR (dB)	
1	10 MHz	R.11 TDD	OP.1 TDD	EVA5	2x2 Medium	70	6.8	$\geq 2$
	5 MHz	R.11-2 TDD	OP.1 TDD	EVA5	2x2 Medium	70	6.8	1
2	10 MHz	R.10 TDD	OP.1 TDD	HST	2x2	70	-2.3	$\geq 1$

**8.2.2.2.2 Minimum Requirement 4 Tx Antenna Port**

The requirements are specified in Table 8.2.2.2.2-2, with the addition of the parameters in Table 8.2.2.2.1 and the downlink physical channel setup according to Annex C.3.2. The purpose is to verify the performance of transmit diversity (SFBC-FSTD) with 4 transmitter antennas.

**Table 8.2.2.2.2-1: Test Parameters for Transmit diversity Performance (FRC)**

Parameter	Unit	Test 1-2
Downlink power allocation	$\rho_A$	dB
	$\rho_B$	dB
	$\sigma$	dB
$N_{oc}$ at antenna port		dBm/15kHz
ACK/NACK feedback mode		Multiplexing
PDSCH transmission mode		2
Note 1: $P_B = 1$		

**Table 8.2.2.2.2-2: Minimum performance Transmit Diversity (FRC)**

Test number	Bandwidth	Reference Channel	OCNG Pattern	Propagation Condition	Correlation Matrix and Antenna Configuration	Reference value		UE Category
						Fraction of Maximum Throughput (%)	SNR (dB)	
1	1.4 MHz	R.12 TDD	OP.1 TDD	EPA5	4x2 Medium	70	0.2	$\geq 1$
2	10 MHz	R.13 TDD	OP.1 TDD	ETU70	4x2 Low	70	-0.5	$\geq 1$

### 8.2.2.2.3 Minimum Requirement 2 Tx Antenna Port (demodulation subframe overlaps with aggressor cell ABS)

The requirements are specified in Table 8.2.2.2.3-2, with the addition of parameters in Table 8.2.2.2.3-1 and the downlink physical channel setup according to Annex C.3.2 and Annex C.3.3. The purpose is to verify the performance of transmit diversity (SFBC) with 2 transmit antennas if the PDSCH transmission in the serving cell takes place in subframes that overlap with ABS [9] of the aggressor cell. In Table 8.2.2.2.3-1, Cell 1 is the serving cell, and Cell 2 is the aggressor cell. The downlink physical channel setup for Cell 1 is according to Annex C.3.2 and for Cell 2 is according to Annex C.3.3, respectively.

**Table 8.2.2.2.3-1: Test Parameters for Transmit diversity Performance (FRC)**

Parameter	Unit	Cell 1	Cell 2	
Uplink downlink configuration		1	1	
Special subframe configuration		4	4	
Downlink power allocation	$\rho_A$	dB	-3	-3
	$\rho_B$	dB	-3 (Note 1)	-3 (Note 1)
	$\sigma$	dB	0	N/A
$N_{oc}$ at antenna port	$N_{oc1}$	dBm/15kHz	-102 (Note 2)	N/A
	$N_{oc2}$	dBm/15kHz	-98 (Note 3)	N/A
	$N_{oc3}$	dBm/15kHz	-94.8 (Note 4)	N/A
$E_s/N_{oc2}$	dB	Reference Value in Table 8.2.2.2.3-2	6	
$BW_{channel}$	MHz	10	10	
Subframe Configuration		Non-MBSFN	Non-MBSFN	
Time Offset between Cells	$\mu s$	2.5 (synchronous cells)		
Cell Id		0	1	
ABS pattern (Note 5)		N/A	0000010001 0000000001	
RLM/RRM Measurement Subframe Pattern (Note 6)		0000000001 0000000001	N/A	
CSI Subframe Sets (Note 7)	$C_{CSI,0}$	0000010001 0000000001	N/A	
	$C_{CSI,1}$	1100101000 1100111000	N/A	
Number of control OFDM symbols		2	2	
ACK/NACK feedback mode		Multiplexing	N/A	
PDSCH transmission mode		2	N/A	
Cyclic prefix		Normal	Normal	

Note 1:	$P_B = 1$ .
Note 2:	This noise is applied in OFDM symbols #1, #2, #3, #5, #6, #8, #9, #10, #12, #13 of a subframe overlapping with the aggressor ABS.
Note 3:	This noise is applied in OFDM symbols #0, #4, #7, #11 of a subframe overlapping with the aggressor ABS.
Note 4:	This noise is applied in all OFDM symbols of a subframe overlapping with aggressor non-ABS.
Note 5:	ABS pattern as defined in [9].
Note 6:	Time-domain measurement resource restriction pattern for PCell measurements as defined in [7].
Note 7:	As configured according to the time-domain measurement resource restriction pattern for CSI measurements defined in [7].
Note 8:	Cell 1 is the serving cell. Cell 2 is the aggressor cell. The number of the CRS ports in Cell1 and Cell2 is the same.
Note 9:	SIB-1 will not be transmitted in Cell2 in this test.

Table 8.2.2.2.3-2: Minimum Performance Transmit Diversity (FRC)

Test Number	Reference Channel	OCNG Pattern		Propagation Conditions (Note 1)		Correlation Matrix and Antenna Configuration	Reference Value		UE Category
		Cell 1	Cell 2	Cell 1	Cell 2		Fraction of Maximum Throughput (%) Note 5	SNR (dB) (Note 2)	
1	R.11-4 TDD Note 4	OP.1 TDD	OP.1 TDD	EVA5	EVA5	2x2 Medium	70	3.8	≥2
<p>Note 1: The propagation conditions for Cell 1 and Cell2 are statistically independent.</p> <p>Note 2: SNR corresponds to <math>E_s/N_{oc2}</math> of cell 1.</p> <p>Note 3: The correlation matrix and antenna configuration apply for Cell 1 and Cell 2.</p> <p>Note 4: Cell 1 Reference channel is modified: PDSCH other than SIB1/paging and its associated PDCCH/PCFICH are transmitted in the serving cell subframe when the subframe is overlapped with the ABS subframe of aggressor cell and the subframe is available in the definition of the reference channel.</p> <p>Note 5: The maximum Throughput is calculated from the total Payload in 2 subframes, averaged over 20ms.</p>									

#### 8.2.2.2.3A Minimum Requirement 2 Tx Antenna Ports (demodulation subframe overlaps with aggressor cell ABS and CRS assistance information are configured)

The requirements are specified in Table 8.2.2.2.3A-2, with the addition of parameters in Table 8.2.2.2.3A-1. The purpose is to verify the performance of transmit diversity (SFBC) with 2 transmit antennas if the PDSCH transmission in the serving cell takes place in subframes that overlap with ABS [9] of the aggressor cell with CRS assistance information. In Table 8.2.2.2.3A-1, Cell 1 is the serving cell, and Cell 2 and Cell 3 are the aggressor cells. The downlink physical channel setup for Cell 1 is according to Annex C.3.2 and for Cell 2 and Cell 3 is according to Annex C.3.3, respectively. The CRS assistance information [7] includes Cell 2 and Cell 3.

Table 8.2.2.2.3A-1: Test Parameters for Transmit diversity Performance (FRC)

Parameter		Unit	Cell 1	Cell 2	Cell 3
Uplink downlink configuration			1	1	1
Special subframe configuration			4	4	4
Downlink power allocation	$\rho_A$	dB	-3	-3	-3
	$\rho_B$	dB	-3 (Note 1)	-3 (Note 1)	-3 (Note 1)
	$\sigma$	dB	0	N/A	N/A
$N_{oc}$ at antenna port	$N_{oc1}$	dBm/15kHz	-98 (Note 2)	N/A	N/A
	$N_{oc2}$	dBm/15kHz	-98 (Note 3)	N/A	N/A
	$N_{oc3}$	dBm/15kHz	-93 (Note 4)	N/A	N/A
$\hat{E}_s/N_{oc2}$	dB	Reference Value in Table 8.2.2.2.3A-2	12	10	
$BW_{Channel}$	MHz	10	10	10	
Subframe Configuration			Non-MBSFN	Non-MBSFN	Non-MBSFN
Time Offset between Cells		$\mu s$	N/A	3	-1
Frequency shift between Cells		Hz	N/A	300	-100
Cell Id			0	126	1
ABS pattern (Note 5)			N/A	000000001 000000001	000000001 000000001
RLM/RRM Measurement Subframe Pattern (Note 6)			000000001 000000001	N/A	N/A
CSI Subframe Sets (Note 7)	$C_{CSI,0}$		000000001 000000001	N/A	N/A
	$C_{CSI,1}$		1100111000 1100111000	N/A	N/A
Number of control OFDM symbols			2	Note 8	Note 8
ACK/NACK feedback mode			Multiplexing	N/A	N/A
PDSCH transmission mode			2	Note 9	Note 9
Cyclic prefix			Normal	Normal	Normal
<p>Note 1: <math>P_B = 1</math>.</p> <p>Note 2: This noise is applied in OFDM symbols #1, #2, #3, #5, #6, #8, #9, #10, #12, #13 of a subframe overlapping with the aggressor ABS.</p> <p>Note 3: This noise is applied in OFDM symbols #0, #4, #7, #11 of a subframe overlapping with the aggressor ABS.</p> <p>Note 4: This noise is applied in all OFDM symbols of a subframe overlapping with aggressor non-ABS.</p> <p>Note 5: ABS pattern as defined in [9].</p> <p>Note 6: Time-domain measurement resource restriction pattern for PCell measurements as defined in [7].</p> <p>Note 7: As configured according to the time-domain measurement resource restriction pattern for CSI measurements defined in [7].</p> <p>Note 8: The number of control OFDM symbols is not available for ABS and is 2 for the subframe indicated by "0" of ABS pattern.</p> <p>Note 9: Downlink physical channel setup in Cell 2 and Cell 3 in accordance with Annex C.3.3 applying OCNB pattern as defined in Annex A.5.</p> <p>Note 10: The number of the CRS ports in Cell 1, Cell 2 and Cell 3 is the same.</p> <p>Note 11: SIB-1 will not be transmitted in Cell 2 and Cell 3 in this test.</p>					



Table 8.2.2.2.3A-2: Minimum Performance Transmit Diversity (FRC)

Test Number	Reference Channel	OCNG Pattern			Propagation Conditions (Note 1)			Correlation Matrix and Antenna Configuration (Note 2)	Reference Value		UE Category
		Cell 1	Cell 2	Cell 3	Cell 1	Cell 2	Cell 3		Fraction of Maximum Throughput (%) Note 5	SNR (dB) (Note 3)	
1	R.11-4 TDD Note 4	OP.1 TDD	OP.1 TDD	OP.1 TDD	EVA5	EVA5	EVA5	2x2 Medium	70	3.5	≥2
<p>Note 1: The propagation conditions for Cell 1, Cell 2 and Cell 3 are statistically independent.</p> <p>Note 2: The correlation matrix and antenna configuration apply for Cell 1, Cell 2 and Cell 3..</p> <p>Note 3: SNR corresponds to <math>\hat{E}_s/N_{oc,2}</math> of cell 1.</p> <p>Note 4: Cell 1 Reference channel is modified: PDSCH other than SIB1/paging and its associated PDCCH/PCFICH are transmitted in the serving cell subframe when the subframe is overlapped with the ABS subframe of aggressor cell and the subframe is available in the definition of the reference channel.</p> <p>Note 5: The maximum Throughput is calculated from the total Payload in 2 subframes, averaged over 20ms.</p>											

#### 8.2.2.2.4 Enhanced Performance Requirement Type A – 2 Tx Antenna Ports with TM3 interference model

The requirements are specified in Table 8.2.2.2.4-2, with the addition of parameters in Table 8.2.2.2.4-1 and the downlink physical channel setup according to Annex C.3.2. The purpose is to verify the performance of transmit diversity (SFBC) with 2 transmit antennas when the PDSCH transmission in the serving cell is interfered by PDSCH of two dominant interfering cells applying transmission mode 3 interference model defined in clause B.5.2. In Table 8.2.2.2.4-1, Cell 1 is the serving cell, and Cell 2, 3 are interfering cells. The downlink physical channel setup is according to Annex C.3.2 for each of Cell 1, Cell 2 and Cell 3, respectively.

**Table 8.2.2.4-1: Test Parameters for Transmit diversity Performance (FRC) with TM3 interference model**

Parameter		Unit	Cell 1	Cell 2	Cell 3
Downlink power allocation	$\rho_A$	dB	-3	-3	-3
	$\rho_B$	dB	-3 (Note 1)	-3	-3
	$\sigma$	dB	0	0	0
Cell-specific reference signals			Antenna ports 0,1	Antenna ports 0,1	Antenna ports 0,1
$N_{oc}$ at antenna port		dBm/15kHz	-98	N/A	N/A
DIP (Note 2)		dB	N/A	-1.73	-8.66
BW <sub>Channel</sub>		MHz	10	10	10
Cyclic Prefix			Normal	Normal	Normal
Cell Id			0	1	2
Number of control OFDM symbols			2	2	2
PDSCH transmission mode			2	N/A	N/A
Interference model			N/A	As specified in clause B.5.2	As specified in clause B.5.2
Probability of occurrence of transmission rank in interfering cells	Rank 1	%	N/A	80	80
	Rank 2	%	N/A	20	20
Reporting interval		ms	5	N/A	N/A
Reporting mode			PUCCH 1-0	N/A	N/A
ACK/NACK feedback mode			Multiplexing	N/A	N/A
Physical channel for CQI reporting			PUSCH(Note 5)	N/A	N/A
cqi-pmi-ConfigurationIndex			4	N/A	N/A
Note 1: $P_B = 1$					
Note 2: The respective received power spectral density of each interfering cell relative to $N_{oc}$ is defined by its associated DIP value as specified in clause B.5.1.					
Note 3: Cell 1 is the serving cell. Cell 2, 3 are the interfering cells.					
Note 4: All cells are time-synchronous.					
Note 5: To avoid collisions between CQI reports and HARQ-ACK it is necessary to report both on PUSCH instead of PUCCH. PDCCH DCI format 0 shall be transmitted in downlink SF#4 and #9 to allow periodic CQI to multiplex with the HARQ-ACK on PUSCH in uplink subframe SF#8 and #3.					

**Table 8.2.2.4-2: Enhanced Performance Requirement Type A, Transmit Diversity (FRC) with TM3 interference model**

Test Number	Reference Channel	OCNG Pattern			Propagation Conditions			Correlation Matrix and Antenna Configuration (Note 3)	Reference Value		UE Category
		Cell 1	Cell 2	Cell 3	Cell 1	Cell 2	Cell 3		Fraction of Maximum Throughput (%)	SINR (dB) (Note 2)	
1	R.46 TDD	OP. 1 TD D	N/A	N/A	EV A70	EV A70	EV A70	2x2 Low	70	-1.4	≥1
Note 1: The propagation conditions for Cell 1, Cell 2 and Cell 3 are statistically independent.											
Note 2: SINR corresponds to $E_s/N_{oc}$ of Cell 1 as defined in clause 8.1.1.											
Note 3: Correlation matrix and antenna configuration parameters apply for each of Cell 1, Cell 2 and Cell 3.											

### 8.2.2.2.5 Minimum Requirement 2 Tx Antenna Port (when *EIMTA-MainConfigServCell-r12* is configured)

The requirements are specified in Table 8.2.2.2.5-2 with the addition of the parameters in Table 8.2.2.2.5-1 and the downlink physical channel setup according to Annex C.3.2. The test purpose is to verify the performance of transmit diversity (SFBC) with 2 transmitter antennas in case of using eIMTA TDD UL-DL reconfiguration for TDD serving cell(s) via monitoring PDCCH with eIMTA-RNTI on a PCell.

**Table 8.2.2.2.5-1: Test Parameters for Transmit diversity Performance (FRC) when EIMTA-MainConfigServCell-r12 is configured**

Parameter	Unit	Value
Downlink power allocation	$\rho_A$	dB
	$\rho_B$	dB
	$\sigma$	dB
$N_{sc}$ at antenna port	dBm/15kHz	-98
Uplink downlink configuration in SIB1 (Note 2)		0
Downlink HARQ reference configuration (eimta-HarqReferenceConfig-r12) (Note 2)		5
Set of dynamic TDD UL-DL configurations (NOTES 2,3)		{0, 1, 2, 3, 4, 5, 6}
Periodicity of monitoring the L1 reconfiguration DCI (eimta-CommandPeriodicity-r12)	ms	10
Set of subframes to monitor the L1 reconfiguration DCI (eimta-CommandSubframeSet-r12) (Note 4)		{0,1,5,6}
Number of DL HARQ processes	Processes	15
PDSCH transmission mode		2
ACK/NACK feedback mode (Note 5)		Multiplexing
Note 1: $P_B = 1$		
Note 2: As specified in Table 4.2-2 in TS 36.211.		
Note 3: UL/DL configuration in PDCCH with eIMTA-RNTI is randomly selected from the given set on a per-DCI basis with equal probability.		
Note 4: The set of subframes to monitor PDCCH with eIMTA-RNTI for frame n includes subframes {1,5,6} in frame n-1 and subframe 0 in frame n. Subframes for reconfiguration DCI transmission are chosen in a random way on a per-DCI basis with equal probability.		
Note 5: PUCCH Format 3 is used for DL HARQ feedback.		

**Table 8.2.2.2.5-2: Minimum performance Transmit diversity when EIMTA-MainConfigServCell-r12 is configured**

Test	Reference channel	OCNG Pattern	Propagation Conditions	Correlation Matrix and Antenna Configuration	Reference value		UE Category
					Fraction of Maximum Throughput (%)	SNR (dB)	
1	R.67 TDD	OP.1 TDD	EVA5	2x2 Medium	70	5.0	$\geq 1$

### 8.2.2.2.6 Enhanced Performance Requirement Type B - 2 Tx Antenna Ports with TM2 interference model

The requirements are specified in Table 8.2.2.2.6-2, with the addition of parameters in Table 8.2.2.2.6-1 and the downlink physical channel setup according to Annex C.3.2. The purpose is to verify the performance of transmit diversity (SFBC) with 2 transmit antennas when the PDSCH transmission in the serving cell is interfered by PDSCH of two interfering cells applying transmission mode 2 interference model defined in clause B.6.1. In Table 8.2.2.2.6-1, Cell 1 is the serving cell, and Cell 2, 3 are interfering cells. The downlink physical channel setup is according to Annex C.3.2 for each of Cell 1, Cell 2 and Cell 3, respectively.

**Table 8.2.2.6-1: Test Parameters for Transmit Diversity Performance (FRC) with TM2 interference model**

Parameter		Unit	Cell 1	Cell 2	Cell 3
Uplink downlink Configuration			1	1	1
Special subframe configuration			4	4	4
Downlink power allocation	$\rho_A$	dB	-3	-3	-3
	$\rho_B$	dB	-3 (Note 1)	-3	-3
	$\sigma$	dB	0	0	0
Cell-specific reference signals			Antenna ports 0,1	Antenna ports 0,1	Antenna ports 0,1
$N_{oc}$ at antenna port		dBm/15kHz	-98		
$\bar{E}_s/N_{oc}$		dB	N/A	13.91	3.34
BW <sub>channel</sub>		MHz	10	10	10
Cyclic Prefix			Normal	Normal	Normal
Cell Id			0	6	1
Number of control OFDM symbols in normal subframes			3	3	3
CFI indicated in PCFICH in normal subframes			3	3	3
Number of control OFDM symbols in special subframes			2	2	2
CFI indicated in PCFICH in special subframes			2	2	2
PDSCH transmission mode			2	2	2
Interference model			N/A	As specified in clause B.6.1	As specified in clause B.6.1
MBSFN			Not configured	Not configured	Not configured
Time offset to cell 1		us	N/A	2	3
Frequency offset to cell 1		Hz	N/A	200	300
NeighCellsInfo-r12 (Note 3)	p-aList-r12		N/A	{dB-6, dB-3, dB0}	{dB-6, dB-3, dB0}
	transmissionModelList-r12		N/A	{2,3,4,8,9}	{2,3,4,8,9}
Note 1: $P_B = 1$					
Note 2: Cell 1 is the serving cell. Cell 2, 3 are the interfering cells.					
Note 3: NeighCellsInfo-r12 is described in subclause 6.3.2 of [7].					

**Table 8.2.2.6-2: Minimum Performance for Enhanced Performance Requirement Type B, Transmit Diversity (FRC) with TM2 interference model**

Test Number	Reference Channel	OCNG Pattern			Propagation Conditions			Correlation Matrix and Antenna Configuration (Note 3)	Reference Value		UE Category
		Cell 1	Cell 2	Cell 3	Cell 1	Cell 2	Cell 3		Fraction of Maximum Throughput (%)	SNR (dB) (Note 2)	
1	R.11-12 TDD	OP. 1 TD D	N/A	N/A	EP A5	EP A5	EP A5	2x2 Low	85	15.3	≥1
Note 1: The propagation conditions for Cell 1, Cell 2 and Cell 3 are statistically independent.											
Note 2: SNR corresponds to $\bar{E}_s/N_{oc}$ of Cell 1 as defined in clause 8.1.1.											
Note 3: Correlation matrix and antenna configuration parameters apply for each of Cell 1, Cell 2 and Cell 3.											

### 8.2.2.2.7 Enhanced Performance Requirement Type B - 2 Tx Antenna Ports with TM9 interference model

The requirements are specified in Table 8.2.2.2.7-2, with the addition of parameters in Table 8.2.2.2.7-1 and the downlink physical channel setup according to Annex C.3.2. The purpose is to verify the performance of transmit diversity (SFBC) with 2 transmit antennas when the PDSCH transmission in the serving cell is interfered by PDSCH of two interfering cells applying transmission mode 9 interference model defined in clause B.6.4. In Table 8.2.2.2.7-1, Cell 1 is the serving cell, and Cell 2, 3 are interfering cells. The downlink physical channel setup is according to Annex C.3.2 for each of Cell 1, Cell 2 and Cell 3, respectively.

**Table 8.2.2.2.7-1: Test Parameters for Transmit Diversity Performance (FRC) with TM9 interference model**

Parameter		Unit	Cell 1	Cell 2	Cell 3
Uplink downlink Configuration			1	1	1
Special subframe configuration			4	4	4
Downlink power allocation	$\rho_A$	dB	-3	0	0
	$\rho_B$	dB	-3 (Note 1)	0	0
	$\sigma$	dB	0	-3	-3
Cell-specific reference signals			Antenna ports 0,1	Antenna ports 0,1	Antenna ports 0,1
$N_{oc}$ at antenna port		dBm/15kHz	-98		
$\bar{E}_s/N_{oc}$		dB	N/A	3.28	0.74
$BW_{channel}$		MHz	10	10	10
Cyclic Prefix			Normal	Normal	Normal
Cell Id			0	1	6
Number of control OFDM symbols in normal subframes			3	3	3
CFI indicated in PCFICH in normal subframes			3	Random from set {1,2,3}	Random from set {1,2,3}
Number of control OFDM symbols in special subframes			2	2	2
CFI indicated in PCFICH in special subframes			2	Random from set {1,2}	Random from set {1,2}
PDSCH transmission mode			2	9	9
Interference model			N/A	As specified in clause B.6.4	As specified in clause B.6.4
CSI reference signals			N/A	Antenna ports 15,16	Antenna ports 15,16
CSI-RS periodicity and subframe offset $T_{CSI-RS} / \Delta_{CSI-RS}$		Subframes	N/A	10 / 4	10 / 4
CSI reference signal configuration			N/A	6	7
Zero-power CSI-RS configuration $l_{CSI-RS} / ZeroPowerCSI-RS$ bitmap		Subframes / bitmap	N/A	9 / 010000000000 0000	9 / 001000000000 0000
Time offset to cell 1		us	N/A	5	-5
Frequency offset to cell 1		Hz	N/A	600	-600
MBSFN			Not configured	Not configured	Not configured
NeighCellsInfo-r12 (Note 4)	p-aList-r12		N/A	{dB-6, dB-3, dB0}	{dB-6, dB-3, dB0}
	transmissionModelList-r12		N/A	{2,3,4,8,9}	{2,3,4,8,9}
Note 1: $P_B = 1$ Note 2: Cell 1 is the serving cell. Cell 2, 3 are the interfering cells. Note 3: CSI-RS configurations are according to [4] subclause 6.10.5.2. Note 4: NeighCellsInfo-r12 is described in subclause 6.3.2 of [7].					

**Table 8.2.2.2.7-2: Minimum Performance for Enhanced Performance Requirement Type B, Transmit Diversity (FRC) with TM9 interference model**

Test Number	Reference Channel	OCNG Pattern			Propagation Conditions			Correlation Matrix and Antenna Configuration (Note 3)	Reference Value		UE Category
		Cell 1	Cell 2	Cell 3	Cell 1	Cell 2	Cell 3		Fraction of Maximum Throughput (%)	SNR (dB) (Note 2)	
1	R.11-11 TDD	OP. 1 TDD	N/A	N/A	EP A5	EP A5	EP A5	2x2 Low	85	8.1	≥1

Note 1: The propagation conditions for Cell 1, Cell 2 and Cell 3 are statistically independent.

Note 2: SNR corresponds to  $E_s/N_{oc}$  of Cell 1 as defined in clause 8.1.1.

Note 3: Correlation matrix and antenna configuration parameters apply for each of Cell 1, Cell 2 and Cell 3.

**8.2.2.2.8 Minimum Requirement 2 Tx Antenna Port (Superposed transmission)**

The requirements are specified in Table 8.2.2.2.8-2, with the addition of the parameters in Table 8.2.2.2.8-1 and the downlink physical channel setup according to Annex C.3.2. The purpose is to verify the minimum performance of transmit diversity (SFBC) with 2 transmitter antennas superposed with simultaneous PDSCH interference.

**Table 8.2.2.2.8-1: Test Parameters for Minimum Requirement 2 Tx Antenna Port - Superposed transmission (FRC)**

Parameter	Unit	Test 1-2
Downlink power allocation	$\rho_A$	dB
	$\rho_B$	dB
	$\sigma$	dB
$N_{oc}$ at antenna port		dBm/15kHz
ACK/NACK feedback mode		Multiplexing
PDSCH transmission mode		2
MUSTIdx (Note 2)		11
p-a-must-r14 (Note 3)		N/A
Note 1: $P_B = 1$		
Note 2: MUSTIdx is decreed in subclause 6.3.3 of [4].		
Note 3: p-a-must-r14 is decreed in subclause 6.3.2 of [7].		

**Table 8.2.2.2.8-2: Minimum Performance for Minimum Requirement 2 Tx Antenna Port - Superposed transmission (FRC)**

Test number	Bandwidth	Reference Channel	OCNG Pattern	Propagation Condition	Correlation Matrix and Antenna Configuration	Reference value		UE Category
						Fraction of Maximum Throughput (%)	SNR (dB)	
1	10 MHz	R.aa TDD	OP.1 TDD	EVA5	2x2 Low	70	13.9	≥1

## 8.2.2.3 Open-loop spatial multiplexing performance

### 8.2.2.3.1 Minimum Requirement 2 Tx Antenna Port

For single carrier, the requirements are specified in Table 8.2.2.3.1-2, with the addition of the parameters in Table 8.2.2.3.1-1 and the downlink physical channel setup according to Annex C.3.2.

For CA with 2 DL CCs, the requirements are specified in Table 8.2.2.3.1-4, with the addition of the parameters in Table 8.2.2.3.1-3 and the downlink physical channel setup according to Annex C.3.2. The purpose is to verify the performance of large delay CDD with 2 transmitter antennas.

For CA with 3 DL CCs, the requirements are specified in Table 8.2.2.3.1-7, based on single carrier requirement specified in Table 8.2.2.3.1-5, with the addition of the parameters in Table 8.2.2.3.1-3 and the downlink physical channel setup according to Annex C.3.2.

For CA with 4 DL CCs, the requirements are specified in Table 8.2.2.3.1-8, based on single carrier requirement specified in Table 8.2.2.3.1-5, with the addition of the parameters in Table 8.2.2.3.1-3 and the downlink physical channel setup according to Annex C.3.2.

For CA with 5 DL CCs, the requirements are specified in Table 8.2.2.3.1-9, based on single carrier requirement specified in Table 8.2.2.3.1-5, with the addition of the parameters in Table 8.2.2.3.1-3 and the downlink physical channel setup according to Annex C.3.2.

For CA with 6 DL CCs, the requirements are specified in Table 8.2.2.3.1-10, based on single carrier requirement specified in Table 8.2.2.3.1-5, with the addition of the parameters in Table 8.2.2.3.1-3 and the downlink physical channel setup according to Annex C.3.2.

For CA with 7 DL CCs, the requirements are specified in Table 8.2.2.3.1-11, based on single carrier requirement specified in Table 8.2.2.3.1-5, with the addition of the parameters in Table 8.2.2.3.1-3 and the downlink physical channel setup according to Annex C.3.2.

The test coverage for different number of component carriers is defined in 8.1.2.4.

**Table 8.2.2.3.1-1: Test Parameters for Large Delay CDD (FRC)**

Parameter	Unit	Test 1-3	
Downlink power allocation	$\rho_A$	dB	-3
	$\rho_B$	dB	-3 (Note 1)
	$\sigma$	dB	0
$N_{oc}$ at antenna port	dBm/15kHz	-98	
ACK/NACK feedback mode		Bundling	
PDSCH transmission mode		3	
Note 1: $P_B = 1$			
Note 2: Void.			
Note 3: Void.			

Table 8.2.2.3.1-2: Minimum performance Large Delay CDD (FRC)

Test number	Bandwidth	Reference Channel	OCNG Pattern	Propagation Condition	Correlation Matrix and Antenna Configuration	Reference value		UE Category
						Fraction of Maximum Throughput (%)	SNR (dB)	
1 (Note 2)	10 MHz	R.11-1 TDD	OP.1 TDD	EVA70	2x2 Low	70	13.1	≥2
2	10 MHz	R.35 TDD	OP.1 TDD	EVA200	2x2 Low	70	20.3	≥2
3	10 MHz	R.35-2 TDD	OP.1 TDD	ETU600	2x2 Low	70	21.1	≥2

Note 1: Void.  
Note 2: For UE that supports CRS interference handling, the CRS assistance information defined in [7] is provided. The CRS assistance information includes two aggressor cells with 2 CRS ports and cell ID of aggressor cells are 1 and 128. For UE that does not support CRS interference handling, CRS assistance information is not provided.

Table 8.2.2.3.1-3: Test Parameters for Large Delay CDD (FRC) for CA

Parameter	Unit	Value
Downlink power allocation	$\rho_A$	dB
	$\rho_B$	dB
	$\sigma$	dB
$N_{oc}$ at antenna port	dBm/15kHz	-98
ACK/NACK feedback mode		PUCCH format 1b with channel selection for Tests in Table 8.2.2.3.1-4; PUCCH format 3 for Tests in Table 8.2.2.3.1-7
PDSCH transmission mode		3

Note 1:  $P_B = 1$   
Note 2: Void  
Note 3: The same PDSCH transmission mode is applied to each component carrier.

Table 8.2.2.3.1-4: Minimum performance Large Delay CDD (FRC) for CA with 2DL CCs

Test number	Bandwidth	Reference Channel	OCNG Pattern	Propagation Condition	Correlation Matrix and Antenna Configuration	Reference value		UE Category
						Fraction of Maximum Throughput (%)	SNR (dB)	
1	2x20 MHz	R.30-1 TDD	OP.1 TDD (Note 1)	EVA70	2x2 Low	70	13.7	≥5
2	20MHz+15MHz	R.30-1 TDD for 20MHz CC	OP.1 TDD (Note 1)	EVA70	2x2 Low	70	13.0	≥5
		R.11-9 TDD for 15MHz CC	OP.1 TDD (Note 1)	EVA70		70	12.9	

Note 1: The OCNG pattern applies for each CC.  
Note 2: The applicability of requirements for different CA configurations and bandwidth combination sets is defined in 8.1.2.3.



Table 8.2.2.3.1-5: Single carrier performance for multiple CA configurations

Band-width	Reference channel	OCNG pattern	Propagation condition	Correlation matrix and antenna config.	Reference value	
					Fraction of maximum throughput (%)	SNR (dB)
1.4MHz	R.11-5 TDD	OP.1 TDD	EVA70	2x2 Low	70	13.2
3MHz	R.11-6 TDD	OP.1 TDD	EVA70	2x2 Low	70	12.8
5MHz	R.11-7 TDD	OP.1 TDD	EVA70	2x2 Low	70	12.6
10 MHz	R.11-8 TDD	OP.1 TDD	EVA70	2x2 Low	70	12.8
15MHz	R.11-9 TDD	OP.1 TDD	EVA70	2x2 Low	70	12.9
20MHz	R.30-1 TDD	OP. 1 TDD	EVA70	2x2 Low	70	13.0

Table 8.2.2.3.1-6: Void

Table 8.2.2.3.1-7: Minimum performance (FRC) based on single carrier performance for CA with 3 DL CCs

Test num.	CA Band-width combination	Requirement	UE category
1	3x20MHz	As specified in Table 8.2.2.3.1-5 per CC	≥5
2	20MHz+20MHz+15MHz	As specified in Table 8.2.2.3.1-5 per CC	≥5

Note 1: The applicability of requirements for different CA configurations and bandwidth combination sets is defined in 8.1.2.3

Table 8.2.2.3.1-8: Minimum performance (FRC) based on single carrier performance for CA with 4 DL CCs

Test num.	CA Band-width combination	Requirement	UE category
1	4x20MHz	As specified in Table 8.2.2.3.1-5 per CC	≥8
2	20MHz+20MHz+20MHz+15MHz	As specified in Table 8.2.2.3.1-5 per CC	≥8

Note 1: The applicability of requirements for different CA configurations and bandwidth combination sets is defined in 8.1.2.3

Table 8.2.2.3.1-9: Minimum performance (FRC) based on single carrier performance for CA with 5 DL CCs

Test num.	CA Band-width combination	Requirement	UE category
1	5x20MHz	As specified in Table 8.2.2.3.1-5 per CC	8, ≥11
2	15MHz+4x20MHz	As specified in Table 8.2.2.3.1-5 per CC	8, ≥11

Note 1: The applicability of requirements for different CA configurations and bandwidth combination sets is defined in 8.1.2.3

Table 8.2.2.3.1-10: Minimum performance (FRC) based on single carrier performance for CA with 6 DL CCs

Test num.	CA Band-width combination	Requirement	UE category
1	6x20MHz	As specified in Table 8.2.2.3.1-5 per CC	8, ≥11

Note 1: The applicability of requirements for different CA configurations and bandwidth combination sets is defined in 8.1.2.3

**Table 8.2.2.3.1-11: Minimum performance (FRC) based on single carrier performance for CA with 7 DL CCs**

Test num.	CA Band-width combination	Requirement	UE category
1	7x20MHz	As specified in Table 8.2.2.3.1-5 per CC	8, ≥11
Note 1: The applicability of requirements for different CA configurations and bandwidth combination sets is defined in 8.1.2.3			

**8.2.2.3.1A Soft buffer management test**

For CA, the requirements are specified in Table 8.2.2.3.1A-2, with the addition of the parameters in Table 8.2.2.3.1A-1 and the downlink physical channel setup according to Annex C.3.2. The purpose is to verify UE performance with proper instantaneous buffer implementation.

**Table 8.2.2.3.1A-1: Test Parameters for soft buffer management test (FRC) for CA**

Parameter	Unit	Test 1-2	
Downlink power allocation	$\rho_A$	dB	-3
	$\rho_B$	dB	-3 (Note 1)
	$\sigma$	dB	0
$N_{oc}$ at antenna port	dBm/15kHz	-98	
ACK/NACK feedback mode		- (Note 2)	
PDSCH transmission mode		3	
Note 1: $P_B = 1$			
Note 2: PUCCH format 1b with channel selection is used to feedback ACK/NACK.			
Note 3: For CA test cases, the same PDSCH transmission mode is applied to each component carrier.			

**Table 8.2.2.3.1A-2: Minimum performance soft buffer management test (FRC) for CA**

Test number	Bandwidth	Reference Channel	OCNG Pattern	Propagation Condition	Correlation Matrix and Antenna Configuration	Reference value		UE Category
						Fraction of Maximum Throughput (%)	SNR (dB)	
1	2x20 MHz	R.30-2 TDD	OP.1 TDD (Note 1)	EVA70	2x2 Low	70	13.2	3
2	2x20 MHz	R.35-1 TDD	OP.1 TDD (Note 1)	EVA5	2x2 Low	70	15.7	4
Note 1: For CA test cases, the OCNG pattern applies for each CC.								
Note 2: The applicability of requirements for different CA configurations and bandwidth combination sets is defined in 8.1.2.3.								

**8.2.2.3.1B Enhanced Performance Requirement Type C - 2Tx Antenna Ports**

The requirements are specified in Table 8.2.2.3.1B-2, with the addition of the parameters in Table 8.2.2.3.1B-1 and the downlink physical channel setup according to Annex C.3.2. The purpose is to verify the performance of large delay CDD with 2 transmitter antennas.

**Table 8.2.2.3.1B-1: Test Parameters for Large Delay CDD (FRC)**

Parameter	Unit	Test 1
Downlink power allocation	$\rho_A$	-3
	$\rho_B$	-3 (Note 1)
	$\sigma$	0
$N_{oc}$ at antenna port	dBm/15kHz	-98
ACK/NACK feedback mode		Bundling
PDSCH transmission mode		3
Note 1: $P_B = 1$		

**Table 8.2.2.3.1B-2: Enhanced Performance Requirement Type C for Large Delay CDD (FRC)**

Test number	Bandwidth	Reference Channel	OCNG Pattern	Propagation Condition	Correlation Matrix and Antenna Configuration	Reference value		UE Category
						Fraction of Maximum Throughput (%)	SNR (dB)	
1	10 MHz	R.11-1 TDD	OP.1 TDD	EVA70	2x2 Medium	70	17.4	$\geq 2$

### 8.2.2.3.1C Enhanced Performance Requirement Type C - 2 Tx Antenna Ports with TM1 interference

The requirements are specified in Table 8.2.2.3.1C-2, with the addition of parameters in Table 8.2.2.3.1C-1 and the downlink physical channel setup according to Annex C.3.2. The purpose is to verify the performance of open-loop spatial multiplexing performance with 2 transmit antennas when the PDSCH transmission in the serving cell is interfered by PDSCH of one dominant interfering cell with transmission mode 1. In Table 8.2.2.3.1C-1, Cell 1 is the serving cell, and Cell 2 is interfering cells. The downlink physical channel setup is according to Annex C.3.2 for each of Cell 1 and Cell 2 respectively.

Table 8.2.2.3.1C-1 Test parameters for Larger Delay CDD (FRC) with TM1 interference

Parameter	Unit	Cell 1		
Bandwidth	MHz	10 MHz		
Downlink power allocation	dB	$\rho_A$	-3	0
		$\rho_B$	-3 (Note 1)	0
		$\sigma$	0	0
Cell-specific reference signals		Antenna ports 0,1	Antenna port 0	
Cyclic Prefix		Normal	Normal	
Cell ID		0	1	
Transmission mode		3	Note 2	
$N_{oc}$ at antenna port	dBm/15kHz	-98	N/A	
$\bar{E}_s/N_{oc}$ (Note 3)	dB	Reference Value in Table 8.2.2.3.1C-2	12.95	
Correlation and antenna configuration		Medium (2x2)	Medium(1x2)	
Number of OFDM symbols for PDCCH		2	N/A	
Max number of HARQ transmissions		4	N/A	
Redundancy version coding sequence		{0,1,2,3}	N/A	
Note 1: $P_B = 1$ Note 2: Downlink physical channel setup in Cell 2 in accordance with Annex C.3.2 applying OCNB pattern OP.5 TDD as defined in Annex A.5.2.5. Note 3: Cell 1 is the serving cell. Cell 2 is the interfering cell. Note 4: All cells are time-synchronous. Note 5: SIB-1 will not be transmitted in Cell2 in this test.				

Table 8.2.2.3.1C-2 Enhanced Performance Requirement Type C, Larger Delay CDD (FRC) with TM1 interference

Test Number	Reference Channel	OCNB Pattern		Propagation Conditions (Note 1)		Reference Value		UE Category
		Cell 1	Cell 2	Cell 1	Cell 2	Fraction of Maximum Throughput (%)	SNR (dB) (Note 2)	
1	R,11-10 TDD	OP.1 TDD	OP.5 TDD	EVA70	EVA70	70	19.6	$\geq 2$
Note 1: The propagation conditions for Cell 1 and Cell 2 are statistically independent. Note 2: SNR corresponds to $\bar{E}_s/N_{oc}$ of Cell 1.								

### 8.2.2.3.2 Minimum Requirement 4 Tx Antenna Port

The requirements are specified in Table 8.2.2.3.2-2, with the addition of the parameters in Table 8.2.2.3.2-1 and the downlink physical channel setup according to Annex C.3.2. The purpose is to verify the performance of large delay CDD with 4 transmitter antennas.

Table 8.2.2.3.2-1: Test Parameters for Large Delay CDD (FRC)

Parameter	Unit	Test 1
Downlink power allocation	$\rho_A$	-6
	$\rho_B$	-6 (Note 1)
	$\sigma$	3
$N_{oc}$ at antenna port	dBm/15kHz	-98
ACK/NACK feedback mode		Bundling
PDSCH transmission mode		3
Note 1: $P_B = 1$ .		

Table 8.2.2.3.2-2: Minimum performance Large Delay CDD (FRC)

Test number	Bandwidth	Reference Channel	OCNG Pattern	Propagation Condition	Correlation Matrix and Antenna Configuration	Reference value		UE Category
						Fraction of Maximum Throughput (%)	SNR (dB)	
1	10 MHz	R.14 TDD	OP.1 TDD	EVA70	4x2 Low	70	14.2	$\geq 2$

### 8.2.2.3.3 Minimum Requirement 2Tx antenna port (demodulation subframe overlaps with aggressor cell ABS)

The requirements for non-MBSFN ABS are specified in Table 8.2.2.3.2, with the addition of parameters in Table 8.2.2.3.3-1 and the downlink physical channel setup according to Annex C.3.2 and Annex C.3.3.

The requirements for MBSFN ABS are specified in Table 8.2.2.3.3-4, with the addition of parameters in Table 8.2.2.3.3-3 and the downlink physical channel setup according to Annex C.3.2 and Annex C.3.3.

The purpose is to verify the performance of large delay CDD with 2 transmitter antennas if the PDSCH transmission in the serving cell takes place in subframes that overlap with ABS [9] of the aggressor cell. In Tables 8.2.2.3.3-1 and 8.2.2.3.3-3, Cell 1 is the serving cell, and Cell 2 is the aggressor cell. The downlink physical channel setup for Cell 1 is according to Annex C.3.2 and for Cell 2 is according to Annex C.3.3, respectively.

Table 8.2.2.3.3-1: Test Parameters for Large Delay CDD (FRC) – Non-MBSFN ABS

Parameter		Unit	Cell 1	Cell 2
Uplink downlink configuration			1	1
Special subframe configuration			4	4
Downlink power allocation	$\rho_A$	dB	-3	-3
	$\rho_B$	dB	-3 (Note 1)	-3 (Note 1)
	$\sigma$	dB	0	N/A
$N_{oc}$ at antenna port	$N_{oc1}$	dBm/15kHz	-102 (Note 2)	N/A
	$N_{oc2}$	dBm/15kHz	-98 (Note 3)	N/A
	$N_{oc3}$	dBm/15kHz	-94.8 (Note 4)	N/A
$E_s/N_{oc2}$		dB	Reference Value in Table 8.2.2.3.3-2	6
BW <sub>Channel</sub>		MHz	10	10
Subframe Configuration			Non-MBSFN	Non-MBSFN
Cell Id			0	1
Time Offset between Cells		$\mu$ s	2.5 (synchronous cells)	
ABS pattern (Note 5)			N/A	0000010001, 0000000001
RLM/RRM Measurement Subframe Pattern (Note 6)			0000000001, 0000000001	N/A
CSI Subframe Sets (Note 7)	$C_{CSI,0}$		0000010001, 0000000001	N/A
	$C_{CSI,1}$		1100101000, 1100111000	N/A
Number of control OFDM symbols			2	2
ACK/NACK feedback mode			Multiplexing	N/A
PDSCH transmission mode			3	N/A
Cyclic prefix			Normal	Normal
<p>Note 1: <math>P_B = 1</math>.</p> <p>Note 2: This noise is applied in OFDM symbols #1, #2, #3, #5, #6, #8, #9, #10, #12, #13 of a subframe overlapping with the aggressor ABS.</p> <p>Note 3: This noise is applied in OFDM symbols #0, #4, #7, #11 of a subframe overlapping with the aggressor ABS.</p> <p>Note 4: This noise is applied in all OFDM symbols of a subframe overlapping with aggressor non-ABS.</p> <p>Note 5: ABS pattern as defined in [9].</p> <p>Note 6: Time-domain measurement resource restriction pattern for PCell measurements as defined in [7].</p> <p>Note 7: As configured according to the time-domain measurement resource restriction pattern for CSI measurements defined in [7].</p> <p>Note 8: Cell 1 is the serving cell. Cell 2 is the aggressor cell. The number of the CRS ports in Cell1 and Cell2 is the same.</p> <p>Note 9: SIB-1 will not be transmitted in Cell2 in this test.</p>				

Table 8.2.2.3.3-2: Minimum Performance Large Delay CDD (FRC) – Non-MBSFN ABS

Test Number	Reference Channel	OCNG Pattern		Propagation Conditions (Note 1)		Correlation Matrix and Antenna Configuration	Reference Value		UE Category
		Cell 1	Cell 2	Cell 1	Cell 2		Fraction of Maximum Throughput (%) Note 5	SNR (dB) (Note 2)	
1	R.11 TDD Note 4	OP.1 TDD	OP.1 TDD	EVA 5	EVA 5	2x2 Low	70	14.0	≥2
<p>Note 1: The propagation conditions for Cell 1 and Cell2 are statistically independent.</p> <p>Note 2: SNR corresponds to <math>E_s/N_{oc2}</math> of cell 1.</p> <p>Note 3: The correlation matrix and antenna configuration apply for Cell 1 and Cell 2.</p> <p>Note 4: Cell 1 Reference channel is modified: PDSCH other than SIB1/paging and its associated PDCCH/PCFICH are transmitted in the serving cell subframe when the subframe is overlapped with the ABS subframe of aggressor cell and the subframe is available in the definition of the reference channel.</p> <p>Note 5: The maximum Throughput is calculated from the total Payload in 2 subframes, averaged over 20ms.</p>									

Table 8.2.2.3.3-3: Test Parameters for Large Delay CDD (FRC) – MBSFN ABS

Parameter		Unit	Cell 1	Cell 2
Uplink downlink configuration			1	1
Special subframe configuration			4	4
Downlink power allocation	$\rho_A$	dB	-3	-3
	$\rho_B$	dB	-3 (Note 1)	-3 (Note 1)
	$\sigma$	dB	0	N/A
$N_{oc}$ at antenna port	$N_{oc1}$	dBm/15kHz	-102 (Note 2)	N/A
	$N_{oc2}$	dBm/15kHz	-98 (Note 3)	N/A
	$N_{oc3}$	dBm/15kHz	-94.8 (Note 4)	N/A
$E_s/N_{oc2}$		dB	Reference Value in Table 8.2.2.3.3-4	6
BW <sub>Channel</sub>		MHz	10	10
Subframe Configuration			Non-MBSFN	MBSFN
Cell Id			0	126
Time Offset between Cells		$\mu$ s	2.5 (synchronous cells)	
ABS pattern (Note 5)			N/A	000000001 000000001
RLM/RRM Measurement Subframe Pattern (Note 6)			000000001 000000001	N/A
CSI Subframe Sets (Note 7)	$C_{CSI,0}$		000000001 000000001	N/A
	$C_{CSI,1}$		1100111000 1100111000	N/A
MBSFN Subframe Allocation (Note 10)			N/A	000010
Number of control OFDM symbols			2	2
ACK/NACK feedback mode			Multiplexing	N/A
PDSCH transmission mode			3	N/A
Cyclic prefix			Normal	Normal
<p>Note 1: <math>P_B = 1</math>.</p> <p>Note 2: This noise is applied in OFDM symbols #1, #2, #3, #4, #5, #6, #7, #8, #9, #10, #11, #12, #13 of a subframe overlapping with the aggressor ABS.</p> <p>Note 3: This noise is applied in OFDM symbol #0 of a subframe overlapping with the aggressor ABS.</p> <p>Note 4: This noise is applied in all OFDM symbols of a subframe overlapping with aggressor non-ABS.</p> <p>Note 5: ABS pattern as defined in [9]. The 10<sup>th</sup> and 20<sup>th</sup> subframes indicated by ABS pattern are MBSFN ABS subframes.</p> <p>Note 6: Time-domain measurement resource restriction pattern for PCell measurements as defined in [7].</p> <p>Note 7: As configured according to the time-domain measurement resource restriction pattern for CSI measurements defined in [7].</p> <p>Note 8: Cell 1 is the serving cell. Cell 2 is the aggressor cell. The number of the CRS ports in Cell1 and Cell2 is the same.</p> <p>Note 9: SIB-1 will not be transmitted in Cell2 in this test.</p> <p>Note 10: MBSFN Subframe Allocation as defined in [7], one frame with 6 bits is chosen for MBSFN subframe allocation.</p>				



Table 8.2.2.3.3-4: Minimum Performance Large Delay CDD (FRC) – MBSFN ABS

Test Number	Reference Channel	OCNG Pattern		Propagation Conditions (Note 1)		Correlation Matrix and Antenna Configuration	Reference Value		UE Category
		Cell 1	Cell 2	Cell 1	Cell 2		Fraction of Maximum Throughput (%) Note 5	SNR (dB) (Note 2)	
1	R.11 TDD Note 4	OP.1 TDD	OP.1 TDD	EVA 5	EVA 5	2x2 Low	70	12.2	≥2
<p>Note 1: The propagation conditions for Cell 1 and Cell2 are statistically independent.</p> <p>Note 2: SNR corresponds to <math>E_s/N_{oc2}</math> of cell 1.</p> <p>Note 3: The correlation matrix and antenna configuration apply for Cell 1 and Cell 2.</p> <p>Note 4: Cell 1 Reference channel is modified: PDSCH other than SIB1/paging and its associated PDCCH/PCFICH are transmitted in the serving cell subframe when the subframe is overlapped with the ABS subframe of aggressor cell and the subframe is available in the definition of the reference channel.</p> <p>Note 5: The maximum Throughput is calculated from the total Payload in 2 subframes, averaged over 20ms.</p>									

#### 8.2.2.3.4 Minimum Requirement 2 Tx Antenna Port (demodulation subframe overlaps with aggressor cell ABS and CRS assistance information are configured)

The requirements for non-MBSFN ABS are specified in Table 8.2.2.3.4-2, with the addition of parameters in Table 8.2.2.3.4-1. The purpose is to verify the performance of large delay CDD with 2 transmitter antennas if the PDSCH transmission in the serving cell takes place in subframes that overlap with ABS [9] of the aggressor cell with CRS assistance information. In Table 8.2.2.3.4-1, Cell 1 is the serving cell, and Cell 2 and Cell3 are the aggressor cells. The downlink physical channel setup for Cell 1 is according to Annex C.3.2 and for Cell 2 and Cell 3 is according to Annex C.3.3, respectively. The CRS assistance information [7] includes Cell 2 and Cell 3.

Table 8.2.2.3.4-1: Test Parameters for Large Delay CDD (FRC) – Non-MBSFN ABS

Parameter		Unit	Cell 1	Cell 2	Cell 3
Uplink downlink configuration			1	1	1
Special subframe configuration			4	4	4
Downlink power allocation	$\rho_A$	dB	-3	-3	-3
	$\rho_B$	dB	-3 (Note 1)	-3 (Note 1)	-3 (Note 1)
	$\sigma$	dB	0	N/A	N/A
$N_{oc}$ at antenna port	$N_{oc1}$	dBm/15kHz	-98 (Note 2)	N/A	N/A
	$N_{oc2}$	dBm/15kHz	-98 (Note 3)	N/A	N/A
	$N_{oc3}$	dBm/15kHz	-93 (Note 4)	N/A	N/A
$\hat{E}_s / N_{oc2}$	dB	Reference Value in Table 8.2.2.3.4-2	Reference Value in Table 8.2.2.3.4-2	Reference Value in Table 8.2.2.3.4-2	
BW <sub>Channel</sub>	MHz	10	10	10	
Subframe Configuration			Non-MBSFN	Non-MBSFN	Non-MBSFN
Time Offset between Cells		$\mu$ s	N/A	3	-1
Frequency shift between Cells		Hz	N/A	300	-100
Cell Id			0	1	126
ABS pattern (Note 5)			N/A	000000001 000000001	000000001 000000001
RLM/RRM Measurement Subframe Pattern (Note 6)			000000001 000000001	N/A	N/A
CSI Subframe Sets (Note 7)	C <sub>CSI,0</sub>		000000001 000000001	N/A	N/A
	C <sub>CSI,1</sub>		1100111000 1100111000	N/A	N/A
Number of control OFDM symbols			2	Note 8	Note 8
ACK/NACK feedback mode			Multiplexing	N/A	N/A
PDSCH transmission mode			3	Note 9	Note 9
Cyclic prefix			Normal	Normal	Normal
<p>Note 1: <math>P_B = 1</math>.</p> <p>Note 2: This noise is applied in OFDM symbols #1, #2, #3, #5, #6, #8, #9, #10, #12, #13 of a subframe overlapping with the aggressor ABS.</p> <p>Note 3: This noise is applied in OFDM symbols #0, #4, #7, #11 of a subframe overlapping with the aggressor ABS.</p> <p>Note 4: This noise is applied in all OFDM symbols of a subframe overlapping with aggressor non-ABS</p> <p>Note 5: ABS pattern as defined in [9].</p> <p>Note 6: Time-domain measurement resource restriction pattern for PCell measurements as defined in [7]</p> <p>Note 7: As configured according to the time-domain measurement resource restriction pattern for CSI measurements defined in [7].</p> <p>Note 8: The number of control OFDM symbols is not available for ABS and is 2 for the subframe indicated by "0" of ABS pattern.</p> <p>Note 9: Downlink physical channel setup in Cell 2 and Cell 3 in accordance with Annex C.3.3 applying OCNG pattern as defined in Annex A.5.</p> <p>Note 10: The number of the CRS ports in Cell1, Cell2 and Cell 3 is the same.</p> <p>Note 11: SIB-1 will not be transmitted in Cell2 and Cell 3 in this test.</p>					

Table 8.2.2.3.4-2: Minimum Performance Large Delay CDD (FRC) – Non-MBSFN ABS

Test Number	Reference Channel	$\bar{E}_s/N_{oc2}$		OCNG Pattern			Propagation Conditions (Note1)			Correlation Matrix and Antenna Configuration (Note 2)	Reference Value		UE Category
		Cell 2	Cell 3	Cell 1	Cell 2	Cell 3	Cell 1	Cell 2	Cell 3		Fraction of Maximum Throughput (%) Note 5	SNR (dB) (Note 3)	
1	R.11 TDD Note 4	9	7	OP.1 TDD	OP.1 TDD	OP.1 TDD	EVA5	EVA5	EVA5	2x2 Low	70	14.2	≥2
2	R.35 TDD Note 4	9	1	OP.1 TDD	OP.1 TDD	OP.1 TDD	EVA5	EVA5	EVA5	2x2 Low	70	22.7	≥2

Note 1: The propagation conditions for Cell 1, Cell 2 and Cell 3 are statistically independent.  
Note 2: The correlation matrix and antenna configuration apply for Cell 1, Cell 2 and Cell 3.  
Note 3: SNR corresponds to  $\bar{E}_s/N_{oc2}$  of cell 1.  
Note 4: Cell 1 Reference channel is modified: PDSCH other than SIB1/paging and its associated PDCCH/PCFICH are transmitted in the serving cell subframe when the subframe is overlapped with the ABS subframe of aggressor cell and the subframe is available in the definition of the reference channel.  
Note 5: The maximum Throughput is calculated from the total Payload in 2 subframes, averaged over 20ms.

### 8.2.2.3.5 Minimum Requirement 2 Tx Antenna Port (Superposed transmission)

The requirements are specified in Table 8.2.2.3.5-2, with the addition of the parameters in Table 8.2.2.3.5-1 and the downlink physical channel setup according to Annex C.3.2. The purpose is to verify the minimum performance of open-loop spatial multiplexing with 2 transmitter antennas superposed with simultaneous PDSCH interference.

Table 8.2.2.3.5-1: Test Parameters for Minimum Requirement 2 Tx Antenna Port - Superposed transmission (FRC)

Parameter	Unit	Test 1	
Downlink power allocation	$\rho_A$	dB	0
	$\rho_B$	dB	0 (NOTE 1)
	$\sigma$	dB	0
	PDSCH_RA	dB	-3
	PDSCH_RB	dB	-3
$N_{oc}$ at antenna port		dBm/15kHz	-98
ACK/NACK feedback mode			Bundling
PDSCH transmission mode			3
MUSTIdx (Note 2)			10
p-a-must-r14 (Note 3)			-3
Note 1: $P_B = 1$ .			
Note 2: MUSTIdx is described in subclause 6.3.3 of [4].			
Note 3: p-a-must-r14 is described in subclause 6.3.2 of [7].			

**Table 8.2.2.3.5-2: Minimum Performance for Minimum Requirement 2 Tx Antenna Port - Superposed transmission (FRC)**

Test number	Bandwidth	Reference Channel	OCNG Pattern	Propagation Condition	Correlation Matrix and Antenna Configuration	Reference value		UE Category
						Fraction of Maximum Throughput (%)	SNR (dB)	
1	10 MHz	R.bb TDD	OP.1 TDD	EVA5	2x2 Low	70	19.3	≥2

### 8.2.2.3.6 Minimum Requirement 2 Tx Antenna Port (network-based CRS interference mitigation)

The requirements are specified in Table 8.2.2.3.6-2, with the addition of parameters in Table 8.2.2.3.6-1 and the downlink physical channel setup according to Annex C.3.2. The purpose is to verify the performance of open-loop spatial multiplexing performance with 2 transmit antennas when the PDSCH transmission in the serving cell is interfered by CRS of one dominant interfering cell with network-based CRS interference mitigation. In Table 8.2.2.3.6-1, Cell 1 is the serving cell, and Cell 2 is interfering cell. The downlink physical channel setup is according to Annex C.3.2 for each of Cell 1 and Cell 2 respectively.

**Table 8.2.2.3.6-1: Test parameters for Larger Delay CDD (FRC) with network-based CRS interference mitigation**

Parameter	Unit	Cell 1	Cell 2
Bandwidth	MHz	10 MHz	
Uplink downlink configuration		4	
Special subframe configuration		4	
Downlink power allocation	$\rho_A$	-3	0
	$\rho_B$	-3 (Note 1)	0
	$\sigma$	0	0
Cell-specific reference signals		Antenna ports 0,1	Antenna ports 0,1
Cyclic Prefix		Normal	Normal
Cell ID		0	1
Transmission mode		3	NA (Note 4)
$N_{oc}$ at antenna port	dBm/1 5kHz	-98	N/A
$\bar{E}_s/N_{oc}$ (Note 3)	dB	Reference Value in Table 8.2.2.3.6-2	10
Correlation and antenna configuration		Low (2x2)	Low (2x2)
Max number of HARQ transmissions		4	N/A
Redundancy version coding sequence		{0,1,2,3}	N/A
nw-BasedCRS-InterferenceMitigation-r15		Disabled	Enabled
CRS transmission		On	CRS is configured with CRS muting pattern as '10UU1111110UU111000' where every 20 subframes consist of 11 subframes with full system BW CRS and 9 subframes with CRS only on the center 6 PRBs (Note 5)
Note 1: $P_b=1$ Note 2: Cell 1 is the serving cell. Cell 2 is the interfering cell. Note 3: All cells are time-synchronous. Note 4: Cell 2 has no PDSCH/PDCCH configured Note 5: The muting pattern '10UU1111110UU111000' follows the Uplink downlink configuration 4 where U indicates uplink subframes, 1 indicates DL subframes with full system BW CRS configured and 0 indicates DL subframes including special subframes with CRS only on the center 6 PRBs configured.			

**Table 8.2.2.3.6-2: Minimum performance Large Delay CDD (FRC) with network-based CRS interference mitigation**

Test Number	Reference Channel	OCNG Pattern		Propagation Conditions (Note 1)		Reference Value		UE Category
		Cell 1	Cell 2	Cell 1	Cell 2	Fraction of Maximum Throughput (%)	SNR (dB) (Note 2)	
1	R.11-13 TDD	OP.1 TDD	NA	EVA5	EVA5	70	15.0	≥2

Note 1: The propagation conditions for Cell 1 and Cell 2 are statistically independent.  
Note 2: SNR corresponds to  $\bar{E}_s/N_{oc}$  of Cell 1.

## 8.2.2.4 Closed-loop spatial multiplexing performance

### 8.2.2.4.1 Minimum Requirement Single-Layer Spatial Multiplexing 2 Tx Antenna Port

The requirements are specified in Table 8.2.2.4.1-2, with the addition of the parameters in Table 8.2.2.4.1-1 and the downlink physical channel setup according to Annex C.3.2. The purpose of these tests is to verify the closed loop rank-one performance with wideband and frequency selective precoding.

**Table 8.2.2.4.1-1: Test Parameters for Single-Layer Spatial Multiplexing (FRC)**

Parameter	Unit	Test 1	Test 2
Downlink power allocation	$\rho_A$	dB	-3
	$\rho_B$	dB	-3 (Note 1)
	$\sigma$	dB	0
$N_{oc}$ at antenna port	dBm/15kHz	-98	-98
Precoding granularity	PRB	6	50
PMI delay (Note 2)	ms	10 or 11	10 or 11
Reporting interval	ms	1 or 4 (Note 3)	1 or 4 (Note 3)
Reporting mode		PUSCH 1-2	PUSCH 3-1
CodeBookSubsetRestriction bitmap		001111	001111
ACK/NACK feedback mode		Multiplexing	Multiplexing
PDSCH transmission mode		4	4

Note 1:  $P_B = 1$ .  
Note 2: If the UE reports in an available uplink reporting instance at subframe SF#n based on PMI estimation at a downlink SF not later than SF#(n-4), this reported PMI cannot be applied at the eNB downlink before SF#(n+4).  
Note 3: For Uplink - downlink configuration 1 the reporting interval will alternate between 1ms and 4ms.

**Table 8.2.2.4.1-2: Minimum performance Single-Layer Spatial Multiplexing (FRC)**

Test number	Bandwidth	Reference Channel	OCNG Pattern	Propagation Condition	Correlation Matrix and Antenna Configuration	Reference value		UE Category
						Fraction of Maximum Throughput (%)	SNR (dB)	
1	10 MHz	R.10 TDD	OP.1 TDD	EVA5	2x2 Low	70	-3.1	≥1
2	10 MHz	R.10 TDD	OP.1 TDD	EPA5	2x2 High	70	-2.8	≥1

## 8.2.2.4.1A Minimum Requirement Single-Layer Spatial Multiplexing 4 Tx Antenna Port

The requirements are specified in Table 8.2.2.4.1A-2, with the addition of the parameters in Table 8.2.2.4.1A-1 and the downlink physical channel setup according to Annex C.3.2. The purpose of these tests is to verify the closed loop rank-one performance with wideband and frequency selective precoding.

Table 8.2.2.4.1A-1: Test Parameters for Single-Layer Spatial Multiplexing (FRC)

Parameter	Unit	Test 1	Test 2
Downlink power allocation	$\rho_A$	dB	-6
	$\rho_B$	dB	-6 (Note 1)
	$\sigma$	dB	3
$N_{oc}$ at antenna port	dBm/15kHz	-98	-98
Precoding granularity	PRB	6	50
PMI delay (Note 2)	ms	10 or 11	10 or 11
Reporting interval	ms	1 or 4 (Note 3)	1 or 4 (Note 3)
Reporting mode		PUSCH 1-2	PUSCH 3-1
CodeBookSubsetRestriction bitmap		0000000000000000 0000000000000000 0000000000000111 1111111111111111	0000000000000000 0000000000000000 0000000000000111 1111111111111111
ACK/NACK feedback mode		Multiplexing	Multiplexing
PDSCH transmission mode		4	4
Note 1: $P_B = 1$ .			
Note 2: If the UE reports in an available uplink reporting instance at subframe SF#n based on PMI estimation at a downlink SF not later than SF#(n-4), this reported PMI cannot be applied at the eNB downlink before SF#(n+4).			
Note 3: For Uplink - downlink configuration 1 the reporting interval will alternate between 1ms and 4ms.			

Table 8.2.2.4.1A-2: Minimum performance Single-Layer Spatial Multiplexing (FRC)

Test number	Bandwidth	Reference Channel	OCNG Pattern	Propagation Condition	Correlation Matrix and Antenna Configuration	Reference value		UE Category	UE DL Category
						Fraction of Maximum Throughput (%)	SNR (dB)		
1	10 MHz	R.13 TDD	OP.1 TDD	EVA5	4x2 Low	70	-3.5	≥1	≥4
2	10MHz 1024QAM	R.101 TDD	OP.1 TDD	EPA5	4x2 Low	70	25.0	TBD	20, ≥ 22

## 8.2.2.4.1B Enhanced Performance Requirement Type A – Single-Layer Spatial Multiplexing 2 Tx Antenna Port with TM4 interference model

The requirements are specified in Table 8.2.2.4.1B-2, with the addition of the parameters in Table 8.2.2.4.1B-1 and the downlink physical channel setup according to Annex C.3.2. The purpose of these tests is to verify the closed loop rank-one performance with wideband precoding with two transmit antennas when the PDSCH transmission in the serving cell is interfered by PDSCH of two dominant interfering cells applying transmission mode 4 interference model defined in clause B.5.3. In Table 8.2.2.4.1B-1, Cell 1 is the serving cell, and Cell 2, 3 are interfering cells. The downlink physical channel setup is according to Annex C.3.2 for each of Cell 1, Cell 2 and Cell 3, respectively.

**Table 8.2.2.4.1B-1: Test Parameters for Single-Layer Spatial Multiplexing (FRC) with TM4 interference model**

Parameter		Unit	Cell 1	Cell 2	Cell 3
Downlink power allocation	$\rho_A$	dB	-3	-3	-3
	$\rho_B$	dB	-3 (Note 1)	-3	-3
	$\sigma$	dB	0	0	0
Cell-specific reference signals			Antenna ports 0,1	Antenna ports 0,1	Antenna ports 0,1
$N_{oc}$ at antenna port		dBm/15kHz	-98	N/A	N/A
DIP (Note 2)		dB	N/A	-1.73	-8.66
BW <sub>Channel</sub>		MHz	10	10	10
Cyclic Prefix			Normal	Normal	Normal
Cell Id			0	1	2
Number of control OFDM symbols			2	2	2
PDSCH transmission mode			6	N/A	N/A
Interference model			N/A	As specified in clause B.5.3	As specified in clause B.5.3
Probability of occurrence of transmission rank in interfering cells	Rank 1	%	N/A	80	80
	Rank 2	%	N/A	20	20
Precoding granularity		PRB	50	6	6
PMI delay (Note 4)		ms	10 or 11	N/A	N/A
Reporting interval		ms	5	N/A	N/A
Reporting mode			PUCCH 1-1	N/A	N/A
CodeBookSubsetRestriction bitmap			1111	N/A	N/A
ACK/NACK feedback mode			Multiplexing	N/A	N/A
Physical channel for CQI reporting			PUSCH(Note 6)	N/A	N/A
cqi-pmi-ConfigurationIndex			4	N/A	N/A
<p>Note 1: <math>P_B = 1</math></p> <p>Note 2: The respective received power spectral density of each interfering cell relative to <math>N_{oc}</math> is defined by its associated DIP value as specified in clause B.5.1.</p> <p>Note 3: Cell 1 is the serving cell. Cell 2, 3 are the interfering cells.</p> <p>Note 4: If the UE reports in an available uplink reporting instance at subframe SF#n based on PMI estimation at a downlink SF not later than SF#(n-4), this reported PMI cannot be applied at the eNB downlink before SF#(n+4).</p> <p>Note 5: All cells are time-synchronous.</p> <p>Note 6: To avoid collisions between CQI reports and HARQ-ACK it is necessary to report both on PUSCH instead of PUCCH. PDCCH DCI format 0 shall be transmitted in downlink SF#4 and #9 to allow periodic CQI to multiplex with the HARQ-ACK on PUSCH in uplink subframe SF#8 and #3.</p>					

**Table 8.2.2.4.1B-2: Enhanced Performance Requirement Type A, Single-Layer Spatial Multiplexing (FRC) with TM4 interference model**

Test Number	Reference Channel	OCNG Pattern			Propagation Conditions			Correlation Matrix and Antenna Configuration (Note 3)	Reference Value		UE Category
		Cell 1	Cell 2	Cell 3	Cell 1	Cell 2	Cell 3		Fraction of Maximum Throughput (%)	SINR (dB) (Note 2)	
1	R.47 TDD	OP. 1 TD D	N/A	N/A	EV A5	EV A5	EV A5	2x2 Low	70	1.1	≥1
Note 1: The propagation conditions for Cell 1, Cell 2 and Cell 3 are statistically independent. Note 2: SINR corresponds to $E_s/N_{oc}$ of Cell 1 as defined in clause 8.1.1. Note 3: Correlation matrix and antenna configuration parameters apply for each of Cell 1, Cell 2 and Cell 3.											

#### 8.2.2.4.1C Minimum Requirement Single-Layer Spatial Multiplexing 2 Tx Antenna Ports (demodulation subframe overlaps with aggressor cell ABS and CRS assistance information are configured)

The requirements are specified in Table 8.2.2.4.1C-2, with the addition of parameters in Table 8.2.2.4.1C-1. The purpose is to verify the closed loop rank-one performance with wideband precoding if the PDSCH transmission in the serving cell takes place in subframes that overlap with ABS [9] of the aggressor cell with CRS assistance information. In Table 8.2.2.4.1C-1, Cell 1 is the serving cell, and Cell 2 and Cell 3 are the aggressor cells. The downlink physical channel setup for Cell 1 is according to Annex C.3.2 and for Cell 2 and Cell 3 is according to Annex C.3.3, respectively. The CRS assistance information [7] includes Cell 2 and Cell 3.



Table 8.2.2.4.1C-1: Test Parameters for Single-Layer Spatial Multiplexing (FRC) – Non-MBSFN ABS

Parameter		Unit	Cell 1	Cell 2	Cell 3
Uplink downlink configuration			1	1	1
Special subframe configuration			4	4	4
Downlink power allocation	$\rho_A$	dB	-3	-3	-3
	$\rho_B$	dB	-3 (Note 1)	-3 (Note 1)	-3 (Note 1)
	$\sigma$	dB	0	N/A	N/A
$N_{oc}$ at antenna port	$N_{oc1}$	dBm/15kHz	-98 (Note 2)	N/A	N/A
	$N_{oc2}$	dBm/15kHz	-98 (Note 3)	N/A	N/A
	$N_{oc3}$	dBm/15kHz	-93 (Note 4)	N/A	N/A
$\tilde{E}_s/N_{oc2}$		dB	Reference Value in Table 8.2.2.4.1C-2	12	10
BW <sub>Channel</sub>		MHz	10	10	10
Subframe Configuration			Non-MBSFN	Non-MBSFN	Non-MBSFN
Time Offset between Cells		μs	N/A	3	-1
Frequency shift between Cells		Hz	N/A	300	-100
Cell Id			0	126	1
ABS pattern (Note 5)			N/A	0000000001 0000000001	0000000001 0000000001
RLM/RRM Measurement Subframe Pattern (Note 6)			0000000001 0000000001	N/A	N/A
CSI Subframe Sets (Note 7)	C <sub>CSI,0</sub>		0000000001 0000000001	N/A	N/A
	C <sub>CSI,1</sub>		1100111000 1100111000	N/A	N/A
Number of control OFDM symbols			2	Note 8	Note 8
ACK/NACK feedback mode			Multiplexing	N/A	N/A
PDSCH transmission mode			6	Note 9	Note 9
Precoding granularity		PRB	50	N/A	N/A
PMI delay (Note 10)		ms	10 or 11	N/A	N/A
Reporting interval		ms	1 or 4 (Note 11)	N/A	N/A
Reporting mode			PUSCH 3-1	N/A	N/A
CodeBookSubsetRestriction bitmap			1111	N/A	N/A
Cyclic prefix			Normal	Normal	Normal
Note 1: $P_B = 1$ .					
Note 2: This noise is applied in OFDM symbols #1, #2, #3, #5, #6, #8, #9, #10, #12, #13 of a subframe overlapping with the aggressor ABS.					
Note 3: This noise is applied in OFDM symbols #0, #4, #7, #11 of a subframe overlapping with the aggressor ABS.					
Note 4: This noise is applied in all OFDM symbols of a subframe overlapping with aggressor non-ABS					
Note 5: ABS pattern as defined in [9].					
Note 6: Time-domain measurement resource restriction pattern for PCell measurements as defined in [7]					
Note 7: As configured according to the time-domain measurement resource restriction pattern for CSI measurements defined in [7].					
Note 8: The number of control OFDM symbols is not available for ABS and is 2 for the subframe indicated by "0" of ABS pattern.					
Note 9: Downlink physical channel setup in Cell 2 and Cell 3 in accordance with Annex C.3.3 applying OCNG pattern as defined in Annex A.5.					
Note 10: If the UE reports in an available uplink reporting instance at subframe SF#n based on PMI estimation at a downlink SF not later than SF#(n-4), this reported PMI cannot be applied at the eNB downlink before SF#(n+4).					
Note 11: For Uplink - downlink configuration 1 the reporting interval will alternate between 1ms and 4ms.					
Note 12: The number of the CRS ports in Cell 1, Cell 2 and Cell 3 is the same.					
Note 13: SIB-1 will not be transmitted in Cell 2 and Cell 3 in this test.					

**Table 8.2.2.4.1C-2: Minimum Performance Single-Layer Spatial Multiplexing (FRC)– Non-MBSFN ABS**

Test Number	Reference Channel	OCNG Pattern			Propagation Conditions (Note1)			Correlation Matrix and Antenna Configuration (Note 2)	Reference Value		UE Category
		Cell 1	Cell 2	Cell 3	Cell 1	Cell 2	Cell 3		Fraction of Maximum Throughput (%) Note 5	SNR (dB) (Note 3)	
1	R.11 TDD Note 4	OP.1 TDD	OP.1 FDD	OP.1 TDD	EPA5	EPA5	EPA5	2x2 High	70	6.4	≥2
<p>Note 1: The propagation conditions for Cell 1, Cell 2 and Cell 3 are statistically independent.</p> <p>Note 2: The correlation matrix and antenna configuration apply for Cell 1, Cell 2 and Cell 3.</p> <p>Note 3: SNR corresponds to <math>\bar{E}_s/N_{oc2}</math> of cell 1.</p> <p>Note 4: Cell 1 Reference channel is modified: PDSCH other than SIB1/paging and its associated PDCCH/PCFICH are transmitted in the serving cell subframe when the subframe is overlapped with the ABS subframe of aggressor cell and the subframe is available in the definition of the reference channel.</p> <p>Note 5: The maximum Throughput is calculated from the total Payload in 2 subframes, averaged over 20ms.</p>											

#### 8.2.2.4.1D Enhanced Performance Requirement Type B - Single-layer Spatial Multiplexing 2 Tx Antenna Port with TM4 interference model

The requirements are specified in Table 8.2.2.4.1D-2, with the addition of the parameters in Table 8.2.2.4.1D-1 and the downlink physical channel setup according to Annex C.3.2. The purpose of these tests is to verify the closed loop rank-one performance with wideband precoding with two transmit antennas when the PDSCH transmission in the serving cell is interfered by PDSCH of two interfering cells applying transmission mode 4 interference model defined in clause B.6.3. In Table 8.2.2.4.1D-1, Cell 1 is the serving cell, and Cell 2, 3 are interfering cells. The downlink physical channel setup is according to Annex C.3.2 for each of Cell 1, Cell 2 and Cell 3, respectively.

**Table 8.2.2.4.1D-1: Test Parameters for Single-layer Spatial Multiplexing (FRC) with TM4 interference model**

Parameter		Unit	Cell 1	Cell 2	Cell 3		
Uplink downlink Configuration			1	1	1		
Special subframe configuration			4	4	4		
Downlink power allocation	$\rho_A$	dB	-3	-3	-3		
	$\rho_B$	dB	-3 (Note 1)	-3	-3		
	$\sigma$	dB	0	0	0		
Cell-specific reference signals			Antenna ports 0,1	Antenna ports 0,1	Antenna ports 0,1		
$N_{oc}$ at antenna port		dBm/15 kHz	-98				
Test number (Note 4)				Test 1	Test 2	Test 1	Test 2
$\bar{E}_s/N_{oc}$		dB	N/A	13.91	3.28	3.34	0.74
Cell Id				6	1	1	6
CFI indicated in PCFICH in normal subframes				3	Random from set {1,2,3}	3	Random from set {1,2,3}
CFI indicated in PCFICH in special subframes				2	Random from set {1,2}	2	Random from set {1,2}
BW <sub>channel</sub>		MHz	10	10	10		
Cyclic Prefix			Normal	Normal	Normal		
Number of control OFDM symbols in normal subframes			3	3	3		
Number of control OFDM symbols in special subframes			2	2	2		
PDSCH transmission mode			4	4	4		
Interference model			N/A	As specified in clause B.6.3	As specified in clause B.6.3		
Precoding			Random wideband precoding per TTI	As specified in clause B.6.3	As specified in clause B.6.3		
Time offset to cell 1		us	N/A	2	3		
Frequency offset to cell 1		Hz	N/A	200	300		
MBSFN			Not configured	Not configured	Not configured		
NeighCellsInfo-r12 (Note 3)	p-aList-r12		N/A	{dB-6, dB-3, dB0}	{dB-6, dB-3, dB0}		
	transmissionModeList-r12		N/A	{2,3,4,8,9}	{2,3,4,8,9}		
Note 1: $P_B = 1$							
Note 2: Cell 1 is the serving cell. Cell 2, 3 are the interfering cells.							
Note 3: NeighCellsInfo-r12 is described in subclause 6.3.2 of [7].							
Note 4: Test 1 and Test 2 are defined in Table 8.2.2.4.1D-2.							

**Table 8.2.2.4.1D-2: Minimum Performance for Enhanced Performance Requirement Type B, Single-layer Spatial Multiplexing (FRC) with TM4 interference model**

Test Num	Reference Channel	OCNG Pattern			Propagation Conditions			Correlation Matrix and Antenna Configuration (Note 3)	Reference Value		UE Category
		Cell 1	Cell 2	Cell 3	Cell 1	Cell 2	Cell 3		Fraction of Maximum Throughput (%)	SNR (dB) (Note 2)	
1	R.11-12 TDD	OP.1 TDD	N/A	N/A	EVA <sub>5</sub>	EVA <sub>5</sub>	EVA <sub>5</sub>	2x2 Low	85	16.1	≥1
2	R.11-11 TDD	OP.1 TDD	N/A	N/A	EPA <sub>5</sub>	EPA <sub>5</sub>	EPA <sub>5</sub>	2x2 Low	85	9.5	≥1

Note 1: The propagation conditions for Cell 1, Cell 2 and Cell 3 are statistically independent.

Note 2: SNR corresponds to  $E_s/N_{oc}$  of Cell 1 as defined in clause 8.1.1.

Note 3: Correlation matrix and antenna configuration parameters apply for each of Cell 1, Cell 2 and Cell 3.

#### 8.2.2.4.1E Minimum Requirement Single-Layer Spatial Multiplexing 2 Tx Antenna Ports with CRS assistance information

The requirements are specified in Table 8.2.2.4.1E-2, with the addition of parameters in Table 8.2.2.4.1E-1. The purpose is to verify the closed loop rank-one performance with wideband precoding when CRS assistance information [7] is configured. In Table 8.2.2.4.1E-1, Cell 1 is the serving cell, and Cell 2 and Cell 3 are the aggressor cells. The downlink physical channel setup is according to Annex C.3.2 for each of Cell 1, Cell 2 and Cell 3, respectively. The CRS assistance information [7] includes Cell 2 and Cell 3.

**Table 8.2.2.4.1E-1: Test Parameters for Single-Layer Spatial Multiplexing (FRC)**

Parameter	Unit	Cell 1	Cell 2	Cell 3
Uplink downlink configuration		1	1	1
Special subframe configuration		4	4	4
Downlink power allocation	$\rho_A$	dB	-3	-3
	$\rho_B$	dB	-3 (Note 1)	-3 (Note 1)
	$\sigma$	dB	0	0

$N_{oc}$ at antenna port		dBm/15kHz	-98	N/A	N/A
$\bar{E}_s/N_{oc}$		dB	Reference Value in Table 8.2.2.4.1E-2	10.45	4.6
$BW_{Channel}$		MHz	10	10	10
Subframe Configuration			Non-MBSFN	Non-MBSFN	Non-MBSFN
Time Offset to Cell 1		$\mu$ s	N/A	3	-1
Frequency shift to Cell 1		Hz	N/A	300	-100
Cell Id			0	1	128
Cell-specific reference signals			Antenna ports 0,1		
Number of control OFDM symbols			2	2	2
Interference model			N/A	As specified in clause B.5.3	As specified in clause B.5.3
Probability of occurrence of transmission in interference cells		%	N/A	20	20
Probability of occurrence of transmission rank in interfering cells	Rank 1	%	N/A	80	80
	Rank 2	%	N/A	20	20
ACK/NACK feedback mode			Multiplexing	N/A	N/A
PDSCH transmission mode			4	N/A	N/A
Precoding granularity	PRB		50	N/A	N/A
PMI delay (Note 2)	ms		10 or 11	N/A	N/A
Reporting interval	ms		1 or 4 (Note 3)	N/A	N/A
Reporting mode			PUSCH 3-1	N/A	N/A
CodeBookSubsetRestriction bitmap			001111	N/A	N/A
Cyclic prefix			Normal	Normal	Normal
<p>Note 1: <math>P_p = 1</math>.</p> <p>Note 2: If the UE reports in an available uplink reporting instance at subframe SF#n based on PMI estimation at a downlink SF not later than SF#(n-4), this reported PMI cannot be applied at the eNB downlink before SF#(n+4).</p> <p>Note 3: For Uplink - downlink configuration 1 the reporting interval will alternate between 1ms and 4ms.</p>					

Table 8.2.2.4.1E-2: Minimum Performance Single-Layer Spatial Multiplexing (FRC)

Test Number	Reference Channel	OCNG Pattern			Propagation Conditions (Note1)			Correlation Matrix and Antenna Configuration (Note 2)	Reference Value		UE Category
		Cell 1	Cell 2	Cell 3	Cell 1	Cell 2	Cell 3		Fraction of Maximum Throughput (%)	SNR (dB) (Note 3)	
1	R.10-3 TDD	OP.1 TDD	N/A	N/A	EVA5	EVA5	EVA5	2x2 Low	70	11.2	$\geq 2$
<p>Note 1: The propagation conditions for Cell 1, Cell 2 and Cell 3 are statistically independent.</p> <p>Note 2: The correlation matrix and antenna configuration apply for Cell 1, Cell 2 and Cell 3.</p> <p>Note 3: SNR corresponds to <math>\bar{E}_s/N_{oc}</math> of cell 1.</p>											

#### 8.2.2.4.1F Minimum Requirement Single-Layer Spatial Multiplexing 4 Tx Antenna Ports with CRS assistance information

The requirements are specified in Table 8.2.2.4.1F-2, with the addition of parameters in Table 8.2.2.4.1F-1. In Table 8.2.2.4.1F-1, Cell 1 is the serving cell, and Cell 2 and Cell 3 are the aggressor cells. The downlink physical channel

setup is according to Annex C.3.2 for each of Cell 1, Cell 2 and Cell 3, respectively. The CRS assistance information [7] is provided to the UE and includes information on Cell 2 and Cell 3.

The purpose of the test is to verify the closed loop single layer TM4 performance under assumption that UE applies CRS interference mitigation in the scenario with 4 CRS antenna ports in the serving and aggressor cells.

**Table 8.2.2.4.1F-1: Test Parameters**

Parameter	Unit	Cell 1	Cell 2	Cell 3
Uplink downlink configuration		1	1	1
Special subframe configuration		4	4	4
Downlink power allocation	$\rho_A$	dB	-6	-6
	$\rho_B$	dB	-6 (Note 1)	-6 (Note 1)
	$\sigma$	dB	3	3
$N_{oc}$ at antenna port	dBm/15kHz	-98	N/A	N/A
$\tilde{E}_s/N_{oc}$	dB	Reference Value in Table 8.2.2.4.1F-2	10.45	4.6
$BW_{Channel}$	MHz	10	10	10
Cyclic prefix		Normal	Normal	Normal
Subframe Configuration		Non-MBSFN	Non-MBSFN	Non-MBSFN
Cell ID		0	1	6
Cell-specific reference signals		Antenna ports 0,1,2,3		
Number of control OFDM symbols (CFI)		2	2	2
PDSCH transmission mode		4	N/A	N/A
Precoding granularity	PRB	50	N/A	N/A
PMI delay (Note 2)	ms	8	N/A	N/A
Reporting interval	ms	1 or 4 (Note 3)	N/A	N/A
Reporting mode		PUSCH 3-1	N/A	N/A
CodeBookSubsetRestriction bitmap		000000000000 FFFF	N/A	N/A
ACK/NACK feedback mode		Multiplexing	N/A	N/A
Time Offset relative to Cell 1	$\mu$ s	N/A	3	-1
Frequency shift relative to Cell 1	Hz	N/A	300	-100
Interference model		N/A	As specified in clause B.5.3	As specified in clause B.5.3
Probability of occurrence of transmission in interference cells	%	N/A	20	20
Probability of occurrence of transmission rank in interfering cells	Rank 1	%	N/A	80
	Rank 2	%	N/A	20
Note 1: $P_{ij} = 1$ . Note 2: If the UE reports in an available uplink reporting instance at subframe SF #n based on PMI estimation at a downlink SF not later than SF #(n-4), this reported PMI cannot be applied at the eNB downlink before SF#(n+4). Note 3: For Uplink - downlink configuration 1 the reporting interval will alternate between 1ms and 4ms.				

**Table 8.2.2.4.1F-2: Minimum Performance for PDSCH**

Test Number	Reference Channel	OCNG Pattern			Propagation Conditions (Note1)			Correlation Matrix and Antenna Configuration (Note 2)	Reference Value		UE Category
		Cell 1	Cell 2	Cell 3	Cell 1	Cell 2	Cell 3		Fraction of Maximum Throughput (%)	SNR (dB) (Note 3)	

1	R.36 TDD	OP.1 TDD	N/A	N/A	EVA5	EVA5	EVA5	4x2 low	70	14.1	$\geq 2$
Note 1: The propagation conditions for Cell 1, Cell 2 and Cell 3 are statistically independent. Note 2: The correlation matrix and antenna configuration apply for Cell 1, Cell 2 and Cell 3. Note 3: SNR corresponds to $\bar{E}_s/N_{oc}$ of cell 1.											

#### 8.2.2.4.2 Minimum Requirement Multi-Layer Spatial Multiplexing 2 Tx Antenna Port

The requirements are specified in Table 8.2.2.4.2-2, with the addition of the parameters in Table 8.2.2.4.2-1 and the downlink physical channel setup according to Annex C.3.2. The purpose of these tests is to verify the closed loop rank-two performance with wideband and frequency selective precoding.

**Table 8.2.2.4.2-1: Test Parameters for Multi-Layer Spatial Multiplexing (FRC)**

Parameter	Unit	Test 1-2	Test 3	
Downlink power allocation	$\rho_A$	dB	-3	-3
	$\rho_B$	dB	-3 (Note 1)	-3 (Note 1)
	$\sigma$	dB	0	0
$N_{oc}$ at antenna port	dBm/15kHz	-98	-98	
Precoding granularity	PRB	50	8	
PMI delay (Note 2)	ms	10 or 11	10 or 11	
Reporting interval	ms	1 or 4 (Note 3)	1 or 4 (Note 3)	
Reporting mode		PUSCH 3-1	PUSCH 1-2	
ACK/NACK feedback mode		Bundling	Bundling	
CodeBookSubsetRestriction bitmap		110000	110000	
PDSCH transmission mode		4	4	
Number of OFDM symbols for PDCCH per component carrier	OFDM symbol	2	1	
Note 1: $P_B = 1$ . Note 2: If the UE reports in an available uplink reporting instance at subframe SF#n based on PMI estimation at a downlink SF not later than SF#(n-4), this reported PMI cannot be applied at the eNB downlink before SF#(n+4). Note 3: For Uplink - downlink configuration 1 the reporting interval will alternate between 1ms and 4ms.				

**Table 8.2.2.4.2-2: Minimum performance Multi-Layer Spatial Multiplexing (FRC)**

Test number	Bandwidth	Reference Channel	OCNG Pattern	Propagation Condition	Correlation Matrix and Antenna Configuration	Reference value		UE Category	UE DL category
						Fraction of Maximum Throughput (%)	SNR (dB)		
1	10 MHz	R.35 TDD	OP.1 TDD	EPA5	2x2 Low	70	19.5	$\geq 2$	$\geq 6$
2	10 MHz	R.11-1 TDD	OP.1 TDD	ETU70	2x2 Low	70	13.9	$\geq 2$	$\geq 6$
3	20 MHz 256QAM	R. 65 TDD	OP.1 TDD	EVA5	2x2 Low	70	24.9	11-12	$\geq 11$

#### 8.2.2.4.2A Enhanced Performance Requirement Type C Multi-Layer Spatial Multiplexing 2 Tx Antenna Port

The requirements are specified in Table 8.2.2.4.2A-2, with the addition of the parameters in Table 8.2.2.4.2A-1 and the downlink physical channel setup according to Annex C.3.2. The purpose of these tests is to verify the closed loop rank-two performance with wideband precoding.

**Table 8.2.2.4.2A-1: Test Parameters for Multi-Layer Spatial Multiplexing (FRC)**

Parameter	Unit	Test 1
Downlink power allocation	$\rho_A$	-3
	$\rho_B$	-3 (Note 1)
	$\sigma$	0
$N_{oc}$ at antenna port	dBm/15kHz	-98
Precoding granularity	PRB	50
PMI delay (Note 2)	ms	10 or 11
Reporting interval	ms	1 or 4 (Note 3)
Reporting mode		PUSCH 3-1
ACK/NACK feedback mode		Bundling
CodeBookSubsetRestriction bitmap		110000
PDSCH transmission mode		4
Note 1:		
Note 2: If the UE reports in an available uplink reporting instance at subframe SF#n based on PMI estimation at a downlink SF not later than SF#(n-4), this reported PMI cannot be applied at the eNB downlink before SF#(n+4).		
Note 3: For Uplink - downlink configuration 1 the reporting interval will alternate between 1ms and 4ms.		

**Table 8.2.2.4.2A-2: Enhanced Performance Requirement Type C for Multi-Layer Spatial Multiplexing (FRC)**

Test number	Bandwidth	Reference Channel	OCNG Pattern	Propagation Condition	Correlation Matrix and Antenna Configuration	Reference value		UE Category
						Fraction of Maximum Throughput (%)	SNR (dB)	
1	10 MHz	R.11-1 TDD	OP.1 TDD	ETU70	2x2 Medium	70	17.8	≥2

### 8.2.2.4.3 Minimum Requirement Multi-Layer Spatial Multiplexing 4 Tx Antenna Port

For single carrier, the requirements are specified in Table 8.2.2.4.3-2, with the addition of the parameters in Table 8.2.2.4.3-1 and the downlink physical channel setup according to Annex C.3.2.

For CA with 2 DL CCs, the requirements are specified in Table 8.2.2.4.3-4, with the addition of the parameters in Table 8.2.2.4.3-3 and the downlink physical channel setup according to Annex C.3.2. The purpose of these tests is to verify the closed loop rank-two performance with wideband and frequency selective precoding.

For CA with 3 DL CCs, the requirements are specified in Table 8.2.2.4.3-7, based on single carrier requirement specified in Table 8.2.2.4.3-5, with the addition of the parameters in Table 8.2.2.4.3-3 and the downlink physical channel setup according to Annex C.3.2.

For CA with 4 DL CCs, the requirements are specified in Table 8.2.2.4.3-8, based on single carrier requirement specified in Table 8.2.2.4.3-5, with the addition of the parameters in Table 8.2.2.4.3-3 and the downlink physical channel setup according to Annex C.3.2.

For CA with 5 DL CCs, the requirements are specified in Table 8.2.2.4.3-9, based on single carrier requirement specified in Table 8.2.2.4.3-5, with the addition of the parameters in Table 8.2.2.4.3-3 and the downlink physical channel setup according to Annex C.3.2.

For CA with 6 DL CCs, the requirements are specified in Table 8.2.2.4.3-10, based on single carrier requirement specified in Table 8.2.2.4.3-5, with the addition of the parameters in Table 8.2.2.4.3-3 and the downlink physical channel setup according to Annex C.3.2.

For CA with 7 DL CCs, the requirements are specified in Table 8.2.2.4.3-11, based on single carrier requirement specified in Table 8.2.2.4.3-5, with the addition of the parameters in Table 8.2.2.4.3-3 and the downlink physical channel setup according to Annex C.3.2.



The test coverage for different number of component carriers is defined in 8.1.2.4.

**Table 8.2.2.4.3-1: Test Parameters for Multi-Layer Spatial Multiplexing (FRC)**

Parameter	Unit	Test 1	
Downlink power allocation	$\rho_A$	dB	-6
	$\rho_B$	dB	-6 (Note 1)
	$\sigma$	dB	3
$N_{oc}$ at antenna port	dBm/15kHz	-98	
Precoding granularity	PRB	6	
PMI delay (Note 2)	ms	10 or 11	
Reporting interval	ms	1 or 4 (Note 3)	
Reporting mode		PUSCH 1-2	
ACK/NACK feedback mode		Bundling	
CodeBookSubsetRestriction bitmap		00000000000000000000000000000000 000011111111111111111100000000 00000000	
PDSCH transmission mode		4	
Note 1: $P_B = 1$ .			
Note 2: If the UE reports in an available uplink reporting instance at subframe SF#n based on PMI estimation at a downlink SF not later than SF#(n-4), this reported PMI cannot be applied at the eNB downlink before SF#(n+4)			
Note 3: For Uplink - downlink configuration 1 the reporting interval will alternate between 1ms and 4ms.			
Note 4: Void.			
Note 5: Void.			
Note 6: Void.			

**Table 8.2.2.4.3-2: Minimum performance Multi-Layer Spatial Multiplexing (FRC)**

Test number	Bandwidth	Reference Channel	OCNG Pattern	Propagation Condition	Correlation Matrix and Antenna Configuration	Reference value		UE Category
						Fraction of Maximum Throughput (%)	SNR (dB)	
1	10 MHz	R.36 TDD	OP.1 TDD	EPA5	4x2 Low	70	15.7	$\geq 2$
Note 1: Void								

**Table 8.2.2.4.3-3: Test Parameters for Multi-Layer Spatial Multiplexing (FRC) for CA**

Parameter	Unit	Value	
Downlink power allocation	$\rho_A$	dB	-6
	$\rho_B$	dB	-6 (Note 1)
	$\sigma$	dB	3
$N_{oc}$ at antenna port	dBm/15kHz	-98	
Precoding granularity	PRB	8	
PMI delay (Note 2)	ms	10 or 11	
Reporting interval	ms	1 or 4 (Note 3)	
Reporting mode		PUSCH 1-2	
ACK/NACK feedback mode		PUCCH format 1b with channel selection for Tests in Table 8.2.2.4.3-4; PUCCH format 3 for Tests in Table 8.2.2.4.3-7, Table 8.2.2.4.3-8 and Table 8.2.2.4.3-9.	
CodeBookSubsetRestriction bitmap		00000000000000000000000000000000 00001111111111111111100000000 00000000	
CSI request field (Note 4)		'10'	
PDSCH transmission mode		4	
Note 1: $P_B = 1$ . Note 2: If the UE reports in an available uplink reporting instance at subframe SF#n based on PMI estimation at a downlink SF not later than SF#(n-4), this reported PMI cannot be applied at the eNB downlink before SF#(n+4) Note 3: For Uplink - downlink configuration 1 the reporting interval will alternate between 1ms and 4ms. Note 4: Multiple CC-s under test are configured as the 1 <sup>st</sup> set of serving cells by high layers. Note 5: The same PDSCH transmission mode is applied to each component carrier.			

**Table 8.2.2.4.3-4: Minimum performance Multi-Layer Spatial Multiplexing (FRC) for CA with 2DL CCs**

Test number	Bandwidth	Reference Channel	OCNG Pattern	Propagation Condition	Correlation Matrix and Antenna Configuration	Reference value		UE Category
						Fraction of Maximum Throughput (%)	SNR (dB)	
1	2x20 MHz	R.43 TDD	OP.1 TDD (Note 1)	EVA5	4x2 Low	70	11.1	≥5
2	20MHz +15MHz z	R.43 TDD for 20MHz CC	OP.1 TDD (Note 1)	EVA5	4x2 Low	70	10.7	≥5
		R.43-5 TDD for 15MHz CC	OP.1 TDD (Note 1)				10.6	
Note 1: The OCNG pattern applies for each CC. Note 2: The applicability of requirements for different CA configurations and bandwidth combination sets is defined in 8.1.2.3.								

Table 8.2.2.4.3-5: Single carrier performance for multiple CA configurations

Band-width	Reference channel	OCNG pattern	Propagation condition	Correlation matrix and antenna config.	Reference value	
					Fraction of maximum throughput (%)	SNR (dB)
1.4MHz	R.43-1 TDD	OP.1 TDD	EVA5	4x2 Low	70	11.0
3MHz	R.43-2 TDD	OP.1 TDD	EVA5	4x2 Low	70	9.8
5MHz	R.43-3 TDD	OP.1 TDD	EVA5	4x2 Low	70	10.0
10 MHz	R.43-4 TDD	OP.1 TDD	EVA5	4x2 Low	70	10.5
15MHz	R.43-5 TDD	OP.1 TDD	EVA5	4x2 Low	70	10.6
20MHz	R.43 TDD	OP.1 TDD	EVA5	4x2 Low	70	10.7

Table 8.2.2.4.3-6: Void

Table 8.2.2.4.3-7: Minimum performance (FRC) based on single carrier performance for CA with 3 DL CCs

Test num.	CA Band-width combination	Requirement	UE category
1	3x20MHz	As specified in Table 8.2.2.4.3-5 per CC	≥5
2	20MHz+20MHz+15MHz	As specified in Table 8.2.2.4.3-5 per CC	≥5

Note 1: The applicability of requirements for different CA configurations and bandwidth combination sets is defined in 8.1.2.3

Table 8.2.2.4.3-8: Minimum performance (FRC) based on single carrier performance for CA with 4 DL CCs

Test num.	CA Band-width combination	Requirement	UE category
1	4x20MHz	As specified in Table 8.2.2.4.3-5 per CC	≥8
2	20MHz+20MHz+20MHz+15MHz	As specified in Table 8.2.2.4.3-5 per CC	≥8

Note 1: The applicability of requirements for different CA configurations and bandwidth combination sets is defined in 8.1.2.3

Table 8.2.2.4.3-9: Minimum performance (FRC) based on single carrier performance for CA with 5 DL CCs

Test num.	CA Band-width combination	Requirement	UE category
1	5x20MHz	As specified in Table 8.2.2.4.3-5 per CC	8, ≥11
2	15MHz+4x20MHz	As specified in Table 8.2.2.4.3-5 per CC	8, ≥11

Note 1: The applicability of requirements for different CA configurations and bandwidth combination sets is defined in 8.1.2.3

Table 8.2.2.4.3-10: Minimum performance (FRC) based on single carrier performance for CA with 6 DL CCs

Test num.	CA Band-width combination	Requirement	UE category
1	6x20MHz	As specified in Table 8.2.2.4.3-5 per CC	8, ≥11

Note 1: The applicability of requirements for different CA configurations and bandwidth combination sets is defined in 8.1.2.3

**Table 8.2.2.4.3-11: Minimum performance (FRC) based on single carrier performance for CA with 7 DL CCs**

Test num.	CA Band-width combination	Requirement	UE category
1	7x20MHz	As specified in Table 8.2.2.4.3-5 per CC	8, ≥11
Note 1: The applicability of requirements for different CA configurations and bandwidth combination sets is defined in 8.1.2.3			

**8.2.2.4.3A Minimum Requirement Multi-Layer Spatial Multiplexing 4 Tx Antenna Port for dual connectivity**

For dual connectivity the requirements are specified in Table 8.2.2.4.3A-3, for 2DL CCs, in Table 8.2.2.4.3A-4 for 3DL CCs, and Table 8.2.2.4.3A-5 for 4DL CCs, based on single carrier requirement specified in Table 8.2.2.4.3A-2, with the addition of the parameters in Table 8.2.2.4.3A-1 and the downlink physical channel setup according to Annex C.3.2. The purpose of these tests is to verify the closed loop rank-two performance with wideband and frequency selective precoding by using dual connectivity.

**Table 8.2.2.4.3A-1: Test Parameters for Multi-Layer Spatial Multiplexing (FRC) for dual connectivity**

Parameter	Unit	Value	
Downlink power allocation	$\rho_A$	dB	-6
	$\rho_B$	dB	-6 (Note 1)
	$\sigma$	dB	3
$N_{sc}$ at antenna port	dBm/15kHz	-98	
Precoding granularity	PRB	6 for 1.4MHz, 4 for 3MHz and 5MHz CCs, 6 for 10MHz CCs, and 8 for 15MHz CCs and 20MHz CCs	
PMI delay (Note 2)	ms	10 or 11	
Reporting interval	ms	1 or 4 (Note 3)	
Reporting mode		PUSCH 1-2	
CodeBookSubsetRestriction bitmap		00000000000000000000000000000000 000011111111111111111100000000 00000000	
PDSCH transmission mode		4	
ACK/NACK transmission		Separate ACK/NACK feedbacks with PUCCH format 1b on the MCG and SCG	
CSI feedback		Separate PUSCH feedbacks on the MCG and SCG	
Time offset between MCG CC and SCG CC	$\mu$ s	0 for UE under test supporting synchronous dual connectivity; 334 for UE under test supporting both asynchronous and synchronous dual connectivity (Note 5)	
Note 1: $P_B = 1$ .			
Note 2: If the UE reports in an available uplink reporting instance at subframe SF#n based on PMI estimation at a downlink SF not later than SF#(n-4), this reported PMI cannot be applied at the eNB downlink before SF#(n+4)			
Note 3: For Uplink - downlink configuration 1 the reporting interval will alternate between 1ms and 4ms.			
Note 4: The same PDSCH transmission mode is applied to each component carrier.			
Note 5: As defined in TS36.300 [11].			
Note 6: If the UE supports both SCG bearer and Split bearer, the SCG bearer is configured.			

**Table 8.2.2.4.3A-2: Single carrier performance for multiple dual connectivity configurations**

Band-width	Reference channel	OCNG pattern	Propagation condition	Correlation matrix and antenna config.	Reference value	
					Fraction of maximum throughput (%)	SNR (dB)
1.4MHz	R.43-1 TDD	OP.1 TDD	EVA5	4x2 Low	70	11.0
3MHz	R.43-2 TDD	OP.1 TDD	EVA5	4x2 Low	70	9.8
5MHz	R.43-3 TDD	OP.1 TDD	EVA5	4x2 Low	70	10.0
10 MHz	R.43-4 TDD	OP.1 TDD	EVA5	4x2 Low	70	10.5
15MHz	R.43-5 TDD	OP.1 TDD	EVA5	4x2 Low	70	10.6
20MHz	R.43 TDD	OP.1 TDD	EVA5	4x2 Low	70	10.7

**Table 8.2.2.4.3A-3: Minimum performance Multi-Layer Spatial Multiplexing (FRC) for dual connectivity**

Test num.	Band-width combination	Requirement	UE category
1	2x20 MHz	As specified in Table 8.2.2.4.3A-2 per CC	≥5
Note 1: The OCNG pattern applies for each CC.			
Note 2: The applicability of requirements for different dual connectivity configurations and bandwidth combination sets is defined in 8.1.2.3A.			

**Table 8.2.2.4.3A-4: Minimum performance Multi-Layer Spatial Multiplexing (FRC) for dual connectivity**

Test num.	Band-width combination	Requirement	UE category
1	3x20 MHz	As specified in Table 8.2.2.4.3A-2 per CC	≥5
Note 1: The OCNG pattern applies for each CC.			
Note 2: The applicability of requirements for different dual connectivity configurations and bandwidth combination sets is defined in 8.1.2.3A.			

**Table 8.2.2.4.3A-5: Minimum performance Multi-Layer Spatial Multiplexing (FRC) for dual connectivity**

Test num.	Band-width combination	Requirement	UE category
1	4x20 MHz	As specified in Table 8.2.2.4.3A-2 per CC	≥8
2	15+20+20+20MHz	As specified in Table 8.2.2.4.3A-2 per CC	≥8
Note 1: The OCNG pattern applies for each CC.			
Note 2: The applicability of requirements for different dual connectivity configurations and bandwidth combination sets is defined in 8.1.2.3A.			

8.2.2.4.4 Void

8.2.2.4.5 Minimum Requirement Multi-Layer Spatial Multiplexing 2 Tx Antenna Port (Superposed transmission)

The requirements are specified in Table 8.2.2.4.5-2, with the addition of the parameters in Table 8.2.2.4.5-1 and the downlink physical channel setup according to Annex C.3.2. The purpose is to verify the minimum performance of closed-loop spatial multiplexing with 2 transmitter antennas superposed with simultaneous PDSCH interference.

**Table 8.2.2.4.5-1: Test Parameters for Minimum Requirement Multi-Layer Spatial Multiplexing 2 Tx Antenna Port - Superposed transmission (FRC)**

Parameter	Unit	Test 1	
Downlink power allocation	$\rho_A$	dB	0
	$\rho_B$	dB	0 (NOTE 1)
	$\sigma$	dB	0
	PDSCH_RA	dB	-3
	PDSCH_RB	dB	-3
$N_{oc}$ at antenna port	dBm/15kHz	-98	
ACK/NACK feedback mode		Multiplexing	
PDSCH transmission mode		4	
Precoding		Random wideband precoding per TTI	
MUSTIdx for transport block 1 (Note 2)		10	
MUSTIdx for transport block 2 (Note 2)		00	
p-a-must-r14 (Note 3)		-3	
Note 1: $P_B = 1$ .			
Note 2: MUSTIdx is decreed in subclause 6.3.3 of [4].			
Note 3: p-a-must-r14 is decreed in subclause 6.3.2 of [7].			

**Table 8.2.2.4.5-2: Minimum Performance for Minimum Requirement Multi-Layer Spatial Multiplexing 2 Tx Antenna Port - Superposed transmission (FRC)**

Test number	Bandwidth	Reference Channel	OCNG Pattern	Propagation Condition	Correlation Matrix and Antenna Configuration	Reference value		UE Category
						Fraction of Maximum Throughput (%)	SNR (dB)	
1	10 MHz	R.bb TDD	OP.1 TDD	EVA5	2x2 Low	70	17.2	$\geq 2$

### 8.2.2.5 MU-MIMO

### 8.2.2.6 [Control channel performance: D-BCH and PCH]

### 8.2.2.7 Carrier aggregation with power imbalance

The requirements in this section verify the ability of an intraband adjacent carrier aggregation UE to demodulate the signal transmitted by the PCell or SCell in the presence of a stronger SCell or PCell signal on an adjacent frequency. Throughput is measured on the PCell or SCell only.

#### 8.2.2.7.1 Minimum Requirement

For CA, the requirements are specified in Table 8.2.2.7.1-2, with the addition of the parameters in Table 8.2.2.7.1-1 and the downlink physical channel setup according to Annex C.3.2.

Table 8.2.2.7.1-1: Test Parameters for CA

Parameter	Unit	Test 1	Test 2
Downlink power allocation	$\rho_A$	dB	0
	$\rho_B$	dB	0 (Note 1)
	$\sigma$	dB	0
$N_{oc}$ at antenna port	dBm/15kHz	Off (Note 2)	Off (Note 2)
Symbols for unused PRBs		OCNG (Note 3)	OCNG (Note 3)
Modulation		64 QAM	64 QAM
Maximum number of HARQ transmission		1	1
Redundancy version coding sequence		{0}	{0}
PDSCH transmission mode of PCell		1	3
PDSCH transmission mode of SCell		3	1
OCNG Pattern	PCell	OP.1 TDD	OP.5 TDD
	SCell	OP.5 TDD	OP.1 TDD
Propagation Conditions	PCell	Clause B.1	Clause B.1
	SCell	Clause B.1	Clause B.1
Correlation Matrix and Antenna	PCell	1x2	2x2
	SCell	2x2	1x2
Note 1: $P_B = 0$ for 1x2 and $P_B = 1$ for 2x2 antenna configuration.			
Note 2: No external noise sources are applied.			
Note 3: These physical resource blocks are assigned to an arbitrary number of virtual UEs with one PDSCH per virtual UE; the data transmitted over the OCNG PDSCHs shall be uncorrelated pseudo random data.			
Note 4: Void.			

Table 8.2.2.7.1-2: Minimum performance (FRC) for CA

Test Number	Bandwidth (MHz)		Reference channel		Power at antenna port (dBm/15KHz)		Reference value Fraction of Maximum Throughput (%)		UE Category
	PCell	SCell	PCell	SCell	$\hat{E}_{s\_PCell}$ for PCell	$\hat{E}_{s\_SCell}$ for SCell	PCell	SCell	
1	20	20	R.49 TDD	NA	-85	-79	85	NA	$\geq 5$
2	20	15	NA	R.49-1 TDD	-79	-85.8	NA	85	$\geq 5$
Note 1: The OCNG pattern for PCell is used to fill the control channel. The OCNG pattern for SCell is used to fill the control channel and PDSCH.									
Note 2: The applicability of requirements for different CA configurations and bandwidth combination sets is defined in 8.1.2.3.									

## 8.2.2.8 Intra-band contiguous carrier aggregation with minimum channel spacing

The requirements in this section verify the ability of an UE supporting intraband contiguous carrier aggregation with minimum channel spacing to demodulate the signal transmitted by the PCell and SCell(s). Throughput is measured on each cell. The minimum channel spacing of intra-band contiguous carrier aggregation refers to the possible minimum channel spacing as any multiple of 300 kHz less than the nominal channel spacing defined in 5.7.1A.

### 8.2.2.8.1 Minimum Requirement

For CA the requirements are specified in Table 8.2.2.8.1-2, with the addition of the parameters in Table 8.2.2.8.1-1 and the downlink physical channel setup according to Annex C.3.2.

Table 8.2.2.8.1-1: Test Parameters for CA

Parameter		Unit	Test 1-2
Downlink power allocation	$\rho_A$	dB	0
	$\rho_B$	dB	0 (Note 1)
	$\sigma$	dB	0
$N_{oc}$ at antenna port		dBm/15kHz	-98
Symbols for unused PRBs			OCNG (Note 2)
Modulation			64QAM
ACK/NACK feedback mode			PUCCH format 1b with channel selection for Test 1; PUCCH format 3 for Test 2
PDSCH transmission mode			1
Note 1: $P_B = 0$			
Note 2: These physical resource blocks are assigned to an arbitrary number of virtual UEs with one PDSCH per virtual UE; the data transmitted over the OCNG PDSCHs shall be uncorrelated pseudo random data, which is QPSK modulated.			
Note 3: The same PDSCH transmission mode is applied to each component carrier.			

Table 8.2.2.8.1-2: Minimum performance (FRC) for intra-band CA with minimum channel spacing

Test number	Bandwidth	Reference Channel	OCNG Pattern	Propagation Condition	Correlation Matrix and Antenna Configuration	Reference value		UE Category
						Fraction of Maximum Throughput (%)	SNR (dB)	
1	2x20MHz	R.9 TDD	OP.1 TDD (Note 1)	EVA5	1x2 Low	70	17.16	≥5
		R.9 TDD	OP.1 TDD (Note 1)			70	17.16	
2	3x20MHz	R.9 TDD	OP.1 TDD (Note 1)	EVA5	1x2 Low	70	17.16	≥5
		R.9 TDD	OP.1 TDD (Note 1)			70	17.16	
		R.9 TDD	OP.1 TDD (Note 1)			70	17.16	
Note 1: The OCNG pattern applies for each CC.								
Note 2: The applicability and test rules of requirements for different CA configurations and bandwidth combination sets are defined in 8.1.2.3.								

## 8.2.2.9 HST-SFN performance

### 8.2.2.9.1 Minimum Requirement

The purpose of this test is to verify UE performance in the HST-SFN scenario defined in B.3A when *highSpeedEnhancedDemodulationFlag* [7] is received.

For single carrier, the requirements are specified in Table 8.2.2.9.1-2, with the addition of the parameters in Table 8.2.2.9.1-1 and the downlink physical channel setup according to Annex C.3.2.

For CA with 2 DL CCs, the requirements are specified in Table 8.2.2.9.1-5, based on single carrier requirement specified in Table 8.2.2.9.1-4, with the addition of the parameters in Table 8.2.2.9.1-3 and the downlink physical channel setup according to Annex C.3.2.

For CA with 3 DL CCs, the requirements are specified in Table 8.2.2.9.1-6, based on single carrier requirement specified in Table 8.2.2.9.1-4, with the addition of the parameters in Table 8.2.2.9.1-3 and the downlink physical channel setup according to Annex C.3.2.

For CA with 4 DL CCs, the requirements are specified in Table 8.2.2.9.1-7, based on single carrier requirement specified in Table 8.2.2.9.1-4, with the addition of the parameters in Table 8.2.2.9.1-3 and the downlink physical channel setup according to Annex C.3.2.



For CA with 5 DL CCs, the requirements are specified in Table 8.2.2.9.1-8, based on single carrier requirement specified in Table 8.2.2.9.1-4, with the addition of the parameters in Table 8.2.2.9.1-3 and the downlink physical channel setup according to Annex C.3.2.

The test coverage for different number of component carriers is defined in 8.1.2.4.

**Table 8.2.2.9.1-1: Test Parameters for UE performance in HST-SFN scenario (FRC)**

Parameter		Unit	Test 1
Downlink power allocation	$\rho_A$	dB	-3
	$\rho_B$	dB	-3 (NOTE 1)
	$\sigma$	dB	0
$N_{oc}$ at antenna port		dBm/15kHz	-98
ACK/NACK feedback mode			Multiplexing
PDSCH transmission mode			3
NOTE 1: $P_B = 1$ .			

**Table 8.2.2.9.1-2: Minimum performance UE in HST-SFN scenario (FRC)**

Test number	Bandwidth	Reference Channel	OCNG Pattern	Propagation Condition	Correlation Matrix and Antenna Configuration	Reference value		UE Category
						Fraction of Maximum Throughput (%)	SNR (dB)	
1	10 MHz	R.87 TDD	OP.1 TDD	HST-SFN	2x2	70	13.2	$\geq 1$
NOTE 1: Test case applicability is defined in 8.1.2.1.								
NOTE 2: The requirement defined is based on the normalized channel model, i.e. the power of each tap is normalized to the instantaneous total received power from four taps.								

**Table 8.2.2.9.1-3: Test Parameters for Large Delay CDD (FRC) for CA**

Parameter		Unit	Value
Downlink power allocation	$\rho_A$	dB	-3
	$\rho_B$	dB	-3 (Note 1)
	$\sigma$	dB	0
$N_{oc}$ at antenna port		dBm/15kHz	-98
ACK/NACK feedback mode			PUCCH format 1b with channel selection for Tests in Table 8.2.2.3.1-4; PUCCH format 3 for Tests in Table 8.2.2.3.1-7
PDSCH transmission mode			3
NOTE 1: $P_B = 1$			
NOTE 2: Void			
NOTE 3: The same PDSCH transmission mode is applied to each component carrier.			

**Table 8.2.2.9.1-4: Single carrier performance for multiple CA configurations**

Bandwidth	Reference channel	OCNG pattern	Propagation condition	Correlation matrix and antenna config.	Reference value	
					Fraction of maximum throughput (%)	SNR (dB)

5 MHz	R.87-2 TDD	OP.1 TDD	HST-SFN	2x2 Low	70	[13.1]
10 MHz	R.87 TDD	OP.1 TDD	HST-SFN	2x2 Low	70	[13.2]
15 MHz	R.87-3 TDD	OP.1 TDD	HST-SFN	2x2 Low	70	[13.4]
20 MHz	R.87-4 TDD	OP.1 TDD	HST-SFN	2x2 Low	70	[13.6]

**Table 8.2.2.9.1-5: Minimum performance (FRC) based on single carrier performance for CA with 2 DL CCs**

Test num.	CA Band-width combination	Requirement	UE category
1	2x20 MHz	As specified in Table 8.2.2.9.1-4 per CC	≥5
2	20 MHz + 15 MHz	As specified in Table 8.2.2.9.1-4 per CC	≥5

NOTE: The applicability of requirements for different CA configurations and bandwidth combination sets is defined in clause 8.1.2.3

**Table 8.2.2.9.1-6: Minimum performance (FRC) based on single carrier performance for CA with 3 DL CCs**

Test num.	CA Band-width combination	Requirement	UE category
1	3x20 MHz	As specified in Table 8.2.2.9.1-4 per CC	≥5
2	20 MHz + 20 MHz + 15 MHz	As specified in Table 8.2.2.9.1-4 per CC	≥5

NOTE: The applicability of requirements for different CA configurations and bandwidth combination sets is defined in clause 8.1.2.3

**Table 8.2.2.9.1-7: Minimum performance (FRC) based on single carrier performance for CA with 4 DL CCs**

Test num.	CA Band-width combination	Requirement	UE category
1	4x20 MHz	As specified in Table 8.2.2.9.1-4 per CC	≥8
2	20 MHz + 20 MHz + 20 MHz + 15 MHz	As specified in Table 8.2.2.9.1-4 per CC	≥8

NOTE: The applicability of requirements for different CA configurations and bandwidth combination sets is defined in clause 8.1.2.3

**Table 8.2.2.9.1-8: Minimum performance (FRC) based on single carrier performance for CA with 5 DL CCs**

Test num.	CA Band-width combination	Requirement	UE category
1	5x20 MHz	As specified in Table 8.2.2.9.1-4 per CC	8, ≥11
2	15 MHz + 4x20 MHz	As specified in Table 8.2.2.9.1-4 per CC	8, ≥11

NOTE: The applicability of requirements for different CA configurations and bandwidth combination sets is defined in clause 8.1.2.3

### 8.2.2.9.2 Minimum Requirement for Rel-16 further enhanced HST

The requirements are specified in Table 8.2.2.9.2-2, with the addition of the parameters in Table 8.2.2.9.2-1 and the downlink physical channel setup according to Annex C.3.2. The purpose of these tests is to verify UE performance in the HST-SFN-500 and HST-500 scenario. The test for HST-SFN-500 scenario defined in B.3B is applied when *highSpeedEnhDemodFlag2-r16* [7] is received. The test for HST-500 scenario defined in B.3C is applied when *highSpeedEnhDemodFlag2-r16* [7] is not received. HST-500 test is not applicable to UE that has passed HST-SFN-500 test.

Table 8.2.2.9.2-1: Test Parameters for UE performance in HST-SFN-500 and HST-500 scenario (FRC)

Parameter		Unit	Test 1
Downlink power allocation	$\rho_A$	dB	-3
	$\rho_B$	dB	-3 (NOTE 1)
	$\sigma$	dB	0
$N_{oc}$ at antenna port		dBm/15kHz	-98
ACK/NACK feedback mode			Multiplexing
PDSCH transmission mode			3
NOTE 1: $P_B = 1$ .			

Table 8.2.2.9.2-2: Minimum performance UE in HST-SFN scenario (FRC)

Test number	Bandwidth	Reference Channel	OCNG Pattern	Propagation Condition	Correlation Matrix and Antenna Configuration	Reference value		UE Category
						Fraction of Maximum Throughput (%)	SNR (dB)	
1 <sup>NOTE 2</sup>	10 MHz	R.87-1 TDD	OP.1 TDD	HST-SFN-500	2x2	70	9.6	$\geq 1$
2	10 MHz	R.87 TDD	OP.1 TDD	HST-500	2x2	70	11.4	$\geq 1$
NOTE 1: Test case applicability is defined in 8.1.2.1 and 8.1.2.6.								
NOTE 2: The requirement defined is based on the normalized channel model, i.e.the power of each tap is normalized to the instantaneous total received power from four taps.								

### 8.2.3 TDD FDD CA (Fixed Reference Channel)

The parameters specified in Table 8.2.3-1 are valid for all the TDD FDD CA tests unless otherwise stated.

Table 8.2.3-1: Common Test Parameters

Parameter		Unit	Value
Uplink downlink configuration (Note 1) for TDD CC only			1
Special subframe configuration (Note 2) for TDD CC only			4
Inter-TTI Distance			1
Maximum number of HARQ processes per component carrier	FDD PCell	Processes	8 for FDD and TDD CCs
	TDD PCell	Processes	11 for FDD CC; 7 for TDD CC
Maximum number of HARQ transmission			4
Redundancy version coding sequence			{0,1,2,3} for QPSK and 16QAM {0,0,1,2} for 64QAM
Number of OFDM symbols for PDCCH per component carrier		OFDM symbols	4 for 1.4 MHz bandwidth, 3 for 3 MHz and 5 MHz bandwidths, 2 for 10 MHz, 15 MHz and 20 MHz bandwidths
Cyclic Prefix			Normal
Cell_ID			0
Cross carrier scheduling			Not configured
ACK/NACK feedback mode			PUCCH format 3
Downlink HARQ-ACK timing	FDD PCell		As specified in Clause 7.3.3 in TS36.213 [6]
	TDD PCell		As specified in Clause 7.3.4 in TS36.213 [6]
Note 1: as specified in Table 4.2-2 in TS 36.211 [4].			
Note 2: as specified in Table 4.2-1 in TS 36.211 [4].			

The applicability of their requirements are specified in Clause 8.1.2.3. The single carrier performance with different bandwidths for multiple CA configurations specified in Clause 8.2.3 cannot be applied for UE single carrier test.

### 8.2.3.1 Single-antenna port performance

The single-antenna performance in a given multi-path fading environments is determined by the SNR for which a certain relative information bit throughput of the reference measurement channels in Annex A.3.3 is achieved. The purpose of these tests is to verify the single-antenna performance with different channel models and MCS.

#### 8.2.3.1.1 Minimum Requirement for FDD PCell

For TDD FDD CA with FDD PCell and 2DL CCs, the requirements are specified in Table 8.2.3.1.1-4 based on single carrier requirement specified in Table 8.2.3.1.1-2 and Table 8.2.3.1.1-3, with the addition of the parameters in Table 8.2.3.1.1-1 and the downlink physical channel setup according to Annex C.3.2.

For TDD FDD CA with FDD PCell and 3DL CCs, the requirements are specified in Table 8.2.3.1.1-5 based on single carrier requirement specified in Table 8.2.3.1.1-2 and Table 8.2.3.1.1-3, with the addition of the parameters in Table 8.2.3.1.1-1 and the downlink physical channel setup according to Annex C.3.2.

For TDD FDD CA with FDD PCell and 4DL CCs, the requirements are specified in Table 8.2.3.1.1-6 based on single carrier requirement specified in Table 8.2.3.1.1-2 and Table 8.2.3.1.1-3, with the addition of the parameters in Table 8.2.3.1.1-1 and the downlink physical channel setup according to Annex C.3.2.

For TDD FDD CA with FDD PCell and 5DL CCs, the requirements are specified in Table 8.2.3.1.1-7 based on single carrier requirement specified in Table 8.2.3.1.1-2 and Table 8.2.3.1.1-3, with the addition of the parameters in Table 8.2.3.1.1-1 and the downlink physical channel setup according to Annex C.3.2.

For TDD FDD CA with FDD PCell and 6DL CCs, the requirements are specified in Table 8.2.3.1.1-8 based on single carrier requirement specified in Table 8.2.3.1.1-2 and Table 8.2.3.1.1-3, with the addition of the parameters in Table 8.2.3.1.1-1 and the downlink physical channel setup according to Annex C.3.2.

For TDD FDD CA with FDD PCell and 7DL CCs, the requirements are specified in Table 8.2.3.1.1-9 based on single carrier requirement specified in Table 8.2.3.1.1-2 and Table 8.2.3.1.1-3, with the addition of the parameters in Table 8.2.3.1.1-1 and the downlink physical channel setup according to Annex C.3.2.

The test coverage for different number of component carriers is defined in 8.1.2.4.

**Table 8.2.3.1.1-1: Test Parameters for CA**

Parameter	Unit	Value	
Downlink power allocation	$\rho_A$	dB	0
	$\rho_B$	dB	0 (Note 1)
	$\sigma$	dB	0
$N_{oc}$ at antenna port	dBm/15kHz	-98	
Symbols for unused PRBs		OCNG (Note 2)	
Modulation		QPSK	
PDSCH transmission mode		1	
Note 1: $P_B = 0$ .			
Note 2: These physical resource blocks are assigned to an arbitrary number of virtual UEs with one PDSCH per virtual UE; the data transmitted over the OCNG PDSCHs shall be uncorrelated pseudo random data, which is QPSK modulated.			
Note 3: The same PDSCH transmission mode is applied to each component carrier.			

**Table 8.2.3.1.1-2: Single carrier performance with different bandwidths for multiple CA configurations for FDD PCell and SCell (FRC)**

Bandwidth	Reference Channel	OCNG Pattern	Propagation Condition	Correlation Matrix and Antenna Configuration	Reference value	
					Fraction of Maximum Throughput (%)	SNR (dB)
1.4 MHz	R.4 FDD	OP.1 FDD	EVA5	1x2 Low	70	-1.3
3 MHz	R.42-1 FDD	OP.1 FDD	EVA5	1x2 Low	70	-1.1
5MHz	R.42-2 FDD	OP.1 FDD	EVA5	1x2 Low	70	-1.0
10MHz	R.2 FDD	OP.1 FDD	EVA5	1x2 Low	70	-1.7
15MHz	R.42-3 FDD	OP.1 FDD	EVA5	1x2 Low	70	-1.6
20MHz	R.42 FDD	OP.1 FDD	EVA5	1x2 Low	70	-1.7

**Table 8.2.3.1.1-3: Single carrier performance with different bandwidths for multiple CA configurations for TDD SCell (FRC)**

Bandwidth	Reference Channel	OCNG Pattern	Propagation Condition	Correlation Matrix and Antenna Configuration	Reference value	
					Fraction of Maximum Throughput (%)	SNR (dB)
1.4 MHz	R.4 TDD	OP.1 TDD	EVA5	1x2 Low	70	-0.6
3 MHz	R.42-1 TDD	OP.1 TDD	EVA5	1x2 Low	70	-0.8
5MHz	R.42-2 TDD	OP.1 TDD	EVA5	1x2 Low	70	-1.2
10MHz	R.2 TDD	OP.1 TDD	EVA5	1x2 Low	70	-1.6
15MHz	R.42-3 TDD	OP.1 TDD	EVA5	1x2 Low	70	-1.4
20MHz	R.42 TDD	OP.1 TDD	EVA5	1x2 Low	70	-1.4

**Table 8.2.3.1.1-4: Minimum performance for multiple CA configurations with 2DL CCs (FRC)**

Test number	CA Bandwidth combination (MHz)			Minimum performance requirement	UE Category
	Total	FDD CC	TDD CC		
1	2x20	20	20	As defined in Table 8.2.3.1.1-2 and Table 8.2.3.1.1-3 per CC	≥5
2	20+10	10	20	As defined in Table 8.2.3.1.1-2 and Table 8.2.3.1.1-3 per CC	≥5
3	20+15	15	20	As defined in Table 8.2.3.1.1-2 and Table 8.2.3.1.1-3 per CC	≥5
Note 1:	The applicability of requirements for different CA configurations and bandwidth combination sets is defined in 8.1.2.3B.				
Note 2:	30usec timing difference between PCell and any SCell is applied in inter-band CA case, where PCell can be assigned on any FDD CC.				

**Table 8.2.3.1.1-5: Minimum performance for multiple CA configurations with 3DL CCs (FRC)**

Test number	CA Bandwidth combination (MHz)			Minimum performance requirement	UE Category
	Total	FDD CC	TDD CC		
1	3x20	20	2x20	As defined in Table 8.2.3.1.1-2 and Table 8.2.3.1.1-3 per CC	≥5
2	20+20+15	15	2x20	As defined in Table 8.2.3.1.1-2 and Table 8.2.3.1.1-3 per CC	≥5
3	20+20+10	10	2x20	As defined in Table 8.2.3.1.1-2 and Table 8.2.3.1.1-3 per CC	≥5
4	3x20	2x20	20	As defined in Table 8.2.3.1.1-2 and Table 8.2.3.1.1-3 per CC	≥5
5	20+20+15	20+15	20	As defined in Table 8.2.3.1.1-2 and Table 8.2.3.1.1-3 per CC	≥5
6	20+20+10	20+10	20	As defined in Table 8.2.3.1.1-2 and Table 8.2.3.1.1-3 per CC	≥5
7	20+10+10	2x10	20	As defined in Table 8.2.3.1.1-2 and Table 8.2.3.1.1-3 per CC	≥5
8	10+15+20	10	15+20	As defined in Table 8.2.3.1.1-2 and Table 8.2.3.1.1-3 per CC	≥5
9	10+15+20	10+15	20	As defined in Table 8.2.3.1.1-2 and Table 8.2.3.1.1-3 per CC	≥5
Note 1:	The applicability of requirements for different CA configurations and bandwidth combination sets is defined in 8.1.2.3B.				
Note 2:	30usec timing difference between PCell and any SCell is applied in inter-band CA case, where PCell can be assigned on any FDD CC.				

Table 8.2.3.1.1-6: Minimum performance for multiple CA configurations with 4DL CCs (FRC)

Test number	CA Bandwidth combination (MHz)			Minimum performance requirement	UE Category
	Total	FDD CC	TDD CC		
1	4x20	20	3x20	As defined in Table 8.2.3.1.1-2 and Table 8.2.3.1.1-3 per CC	≥8
2	4x20	2x20	2x20	As defined in Table 8.2.3.1.1-2 and Table 8.2.3.1.1-3 per CC	≥8
3	3x20+15	20+15	2x20	As defined in Table 8.2.3.1.1-2 and Table 8.2.3.1.1-3 per CC	≥8
4	2x15+2x20	2x15	2x20	As defined in Table 8.2.3.1.1-2 and Table 8.2.3.1.1-3 per CC	≥8
5	3x20+15	2x20+15	20	As defined in Table 8.2.3.1.1-2 and Table 8.2.3.1.1-3 per CC	≥8
6	2x15+2x20	2x15+20	20	As defined in Table 8.2.3.1.1-2 and Table 8.2.3.1.1-3 per CC	≥8
7	3x20+10	2x20+10	20	As defined in Table 8.2.3.1.1-2 and Table 8.2.3.1.1-3 per CC	≥8
8	4x20	3x20	20	As defined in Table 8.2.3.1.1-2 and Table 8.2.3.1.1-3 per CC	≥8
9	10+3x20	10	3x20	As defined in Table 8.2.3.1.1-2 and Table 8.2.3.1.1-3 per CC	≥8
10	2x10+2x20	2x10	2x20	As defined in Table 8.2.3.1.1-2 and Table 8.2.3.1.1-3 per CC	≥8
11	2x10+20+15	2x10	20+15	As defined in Table 8.2.3.1.1-2 and Table 8.2.3.1.1-3 per CC	≥8
12	10+3x20	10+20	2x20	As defined in Table 8.2.3.1.1-2 and Table 8.2.3.1.1-3 per CC	≥8
13	10+15+2x20	10+15	2x20	As defined in Table 8.2.3.1.1-2 and Table 8.2.3.1.1-3 per CC	≥8
14	10+15+2x20	10+15+20	20	As defined in Table 8.2.3.1.1-2 and Table 8.2.3.1.1-3 per CC	≥8
Note 1:	The applicability of requirements for different CA configurations and bandwidth combination sets is defined in 8.1.2.3B.				
Note 2:	30usec timing difference between PCell and any SCell is applied in inter-band CA case, where PCell can be assigned on any CC.				

**Table 8.2.3.1.1-7: Minimum performance for multiple CA configurations with 5DL CCs (FRC)**

Test number	CA Bandwidth combination (MHz)			Minimum performance requirement	UE Category
	Total	FDD CC	TDD CC		
1	15+4x20	15+2x20	2x20	As defined in Table 8.2.3.1.1-2 and Table 8.2.3.1.1-3 per CC	8, ≥11
2	2x15+3x20	2x15+20	2x20	As defined in Table 8.2.3.1.1-2 and Table 8.2.3.1.1-3 per CC	8, ≥11
3	4x20+20	4x20	20	As defined in Table 8.2.3.1.1-2 and Table 8.2.3.1.1-3 per CC	8, ≥11
4	3x20+2x20	3x20	2x20	As defined in Table 8.2.3.1.1-2 and Table 8.2.3.1.1-3 per CC	8, ≥11
5	2x20+3x20	2x20	3x20	As defined in Table 8.2.3.1.1-2 and Table 8.2.3.1.1-3 per CC	8, ≥11
6	20+4x20	20	4x20	As defined in Table 8.2.3.1.1-2 and Table 8.2.3.1.1-3 per CC	8, ≥11
7	10+4x20	10	4x20	As defined in Table 8.2.3.1.1-2 and Table 8.2.3.1.1-3 per CC	8, ≥11
8	10+20+3x20	10+20	3x20	As defined in Table 8.2.3.1.1-2 and Table 8.2.3.1.1-3 per CC	8, ≥11
9	2x10+3x20	2x10	3x20	As defined in Table 8.2.3.1.1-2 and Table 8.2.3.1.1-3 per CC	8, ≥11
10	10+2x20+2x20	10+2x20	2x20	As defined in Table 8.2.3.1.1-2 and Table 8.2.3.1.1-3 per CC	8, ≥11
11	10+15+20+2x20	10+15+20	2x20	As defined in Table 8.2.3.1.1-2 and Table 8.2.3.1.1-3 per CC	8, ≥11
Note 1:	The applicability of requirements for different CA configurations and bandwidth combination sets is defined in 8.1.2.3B.				
Note 2:	30usec timing difference between PCell and any SCell is applied in inter-band CA case, where PCell can be assigned on any CC.				

**Table 8.2.3.1.1-8: Minimum performance for multiple CA configurations with 6DL CCs (FRC)**

Test number	CA Bandwidth combination (MHz)			Minimum performance requirement	UE Category
	Total	FDD CC	TDD CC		
1	1x20+5x20	1x20	5x20	As defined in Table 8.2.3.1.1-2 and Table 8.2.3.1.1-3 per CC	8, ≥11
2	2x20+4x20	2x20	4x20	As defined in Table 8.2.3.1.1-2 and Table 8.2.3.1.1-3 per CC	8, ≥11

**Table 8.2.3.1.1-9: Minimum performance for multiple CA configurations with 7DL CCs (FRC)**

Test number	CA Bandwidth combination (MHz)			Minimum performance requirement	UE Category
	Total	FDD CC	TDD CC		
1	1x20+6x20	1x20	6x20	As defined in Table 8.2.3.1.1-2 and Table 8.2.3.1.1-3 per CC	8, ≥11
2	2x20+5x20	2x20	5x20	As defined in Table 8.2.3.1.1-2 and Table 8.2.3.1.1-3 per CC	8, ≥11

### 8.2.3.1.2 Minimum Requirement for TDD PCell

For TDD FDD CA with TDD PCell and 2DL CCs, the requirements are specified in Table 8.2.3.1.2-4 based on single carrier requirement specified in Table 8.2.3.1.2-2 and Table 8.2.3.1.2-3, with the addition of the parameters in Table 8.2.3.1.2-1 and the downlink physical channel setup according to Annex C.3.2.



For TDD FDD CA with TDD PCell with 3DL CCs, the requirements are specified in Table 8.2.3.1.2-5 based on single carrier requirement specified in Table 8.2.3.1.2-2 and Table 8.2.3.1.2-3, with the addition of the parameters in Table 8.2.3.1.2-1 and the downlink physical channel setup according to Annex C.3.2.

For TDD FDD CA with TDD PCell with 4DL CCs, the requirements are specified in Table 8.2.3.1.2-6 based on single carrier requirement specified in Table 8.2.3.1.2-2 and Table 8.2.3.1.2-3, with the addition of the parameters in Table 8.2.3.1.2-1 and the downlink physical channel setup according to Annex C.3.2.

For TDD FDD CA with TDD PCell with 5DL CCs, the requirements are specified in Table 8.2.3.1.2-7 based on single carrier requirement specified in Table 8.2.3.1.2-2 and Table 8.2.3.1.2-3, with the addition of the parameters in Table 8.2.3.1.2-1 and the downlink physical channel setup according to Annex C.3.2.

For TDD FDD CA with TDD PCell with 6DL CCs, the requirements are specified in Table 8.2.3.1.2-8 based on single carrier requirement specified in Table 8.2.3.1.2-2 and Table 8.2.3.1.2-3, with the addition of the parameters in Table 8.2.3.1.2-1 and the downlink physical channel setup according to Annex C.3.2.

For TDD FDD CA with TDD PCell with 7DL CCs, the requirements are specified in Table 8.2.3.1.2-9 based on single carrier requirement specified in Table 8.2.3.1.2-2 and Table 8.2.3.1.2-3, with the addition of the parameters in Table 8.2.3.1.2-1 and the downlink physical channel setup according to Annex C.3.2.

The test coverage for different number of component carriers is defined in 8.1.2.4.

**Table 8.2.3.1.2-1: Test Parameters for CA**

Parameter	Unit	Value	
Downlink power allocation	$\rho_A$	dB	0
	$\rho_B$	dB	0 (Note 1)
	$\sigma$	dB	0
$N_{oc}$ at antenna port	dBm/15kHz	-98	
Symbols for unused PRBs		OCNG (Note 2)	
Modulation		QPSK	
PDSCH transmission mode		1	
Note 1: $P_B = 0$ .			
Note 2: These physical resource blocks are assigned to an arbitrary number of virtual UEs with one PDSCH per virtual UE; the data transmitted over the OCNG PDSCHs shall be uncorrelated pseudo random data, which is QPSK modulated.			
Note 3: The same PDSCH transmission mode is applied to each component carrier.			

**Table 8.2.3.1.2-2: Single carrier performance with different bandwidths for multiple CA configurations for FDD SCell (FRC)**

Bandwidth	Reference Channel	OCNG Pattern	Propagation Condition	Correlation Matrix and Antenna Configuration	Reference value	
					Fraction of Maximum Throughput (%)	SNR (dB)
1.4 MHz	R.4 FDD	OP.1 FDD	EVA5	1x2 Low	70	-1.3
3 MHz	R.42-1 FDD	OP.1 FDD	EVA5	1x2 Low	70	-1.1
5MHz	R.42-2 FDD	OP.1 FDD	EVA5	1x2 Low	70	-1.0
10MHz	R.2 FDD	OP.1 FDD	EVA5	1x2 Low	70	-1.7
15MHz	R.42-3 FDD	OP.1 FDD	EVA5	1x2 Low	70	-1.6
20MHz	R.42 FDD	OP.1 FDD	EVA5	1x2 Low	70	-1.7

**Table 8.2.3.1.2-3: Single carrier performance with different bandwidths for multiple CA configurations for TDD PCell and SCell (FRC)**

Bandwidth	Reference Channel	OCNG Pattern	Propagation Condition	Correlation Matrix and Antenna Configuration	Reference value	
					Fraction of Maximum Throughput (%)	SNR (dB)
1.4 MHz	R.4 TDD	OP.1 TDD	EVA5	1x2 Low	70	-0.6
3 MHz	R.42-1 TDD	OP.1 TDD	EVA5	1x2 Low	70	-0.8
5MHz	R.42-2 TDD	OP.1 TDD	EVA5	1x2 Low	70	-1.2
10MHz	R.2 TDD	OP.1 TDD	EVA5	1x2 Low	70	-1.6
15MHz	R.42-3 TDD	OP.1 TDD	EVA5	1x2 Low	70	-1.4
20MHz	R.42 TDD	OP.1 TDD	EVA5	1x2 Low	70	-1.4

**Table 8.2.3.1.2-4: Minimum performance for multiple CA configurations with 2DL CCs (FRC)**

Test number	Aggregated Bandwidth (MHz)			Minimum performance requirement	UE Category
	Total	FDD CC	TDD CC		
1	2x20	20	20	As defined in Table 8.2.3.1.2-2 and Table 8.2.3.1.2-3 per CC	≥5
2	20+10	10	20	As defined in Table 8.2.3.1.2-2 and Table 8.2.3.1.2-3 per CC	≥5
3	20+15	15	20	As defined in Table 8.2.3.1.2-2 and Table 8.2.3.1.2-3 per CC	≥5
Note 1:	The applicability of requirements for different CA configurations and bandwidth combination sets is defined in 8.1.2.3B.				
Note 2:	30usec timing difference between PCell and any SCell is applied in inter-band CA case, where PCell can be assigned on any TDD CC.				

**Table 8.2.3.1.2-5: Minimum performance for multiple CA configurations with 3DL CCs (FRC)**

Test number	Aggregated Bandwidth (MHz)			Minimum performance requirement	UE Category
	Total	FDD CC	TDD CC		
1	3x20	20	2x20	As defined in Table 8.2.3.1.2-2 and Table 8.2.3.1.2-3 per CC	≥5
2	20+20+15	15	2x20	As defined in Table 8.2.3.1.2-2 and Table 8.2.3.1.2-3 per CC	≥5
3	20+20+10	10	2x20	As defined in Table 8.2.3.1.2-2 and Table 8.2.3.1.2-3 per CC	≥5
4	3x20	2x20	20	As defined in Table 8.2.3.1.2-2 and Table 8.2.3.1.2-3 per CC	≥5
5	20+20+15	20+15	20	As defined in Table 8.2.3.1.2-2 and Table 8.2.3.1.2-3 per CC	≥5
6	20+20+10	20+10	20	As defined in Table 8.2.3.1.2-2 and Table 8.2.3.1.2-3 per CC	≥5
7	20+10+10	2x10	20	As defined in Table 8.2.3.1.2-2 and Table 8.2.3.1.2-3 per CC	≥5
8	10+15+20	10	15+20	As defined in Table 8.2.3.1.2-2 and Table 8.2.3.1.2-3 per CC	≥5
9	10+15+20	10+15	20	As defined in Table 8.2.3.1.2-2 and Table 8.2.3.1.2-3 per CC	≥5
Note 1:	The applicability of requirements for different CA configurations and bandwidth combination sets is defined in 8.1.2.3B.				
Note 2:	30usec timing difference between PCell and any SCell is applied in inter-band CA case, where PCell can be assigned on any TDD CC.				

Table 8.2.3.1.2-6: Minimum performance for multiple CA configurations with 4DL CCs (FRC)

Test number	CA Bandwidth combination (MHz)			Minimum performance requirement	UE Category
	Total	FDD CC	TDD CC		
1	4x20	20	3x20	As defined in Table 8.2.3.1.2-2 and Table 8.2.3.1.2-3 per CC	≥8
2	4x20	2x20	2x20	As defined in Table 8.2.3.1.2-2 and Table 8.2.3.1.2-3 per CC	≥8
3	3x20+15	20+15	2x20	As defined in Table 8.2.3.1.2-2 and Table 8.2.3.1.2-3 per CC	≥8
4	2x15+2x20	2x15	2x20	As defined in Table 8.2.3.1.2-2 and Table 8.2.3.1.2-3 per CC	≥8
5	3x20+15	2x20+15	20	As defined in Table 8.2.3.1.2-2 and Table 8.2.3.1.2-3 per CC	≥8
6	2x15+2x20	2x15+20	20	As defined in Table 8.2.3.1.2-2 and Table 8.2.3.1.2-3 per CC	≥8
7	3x20+10	2x20+10	20	As defined in Table 8.2.3.1.2-2 and Table 8.2.3.1.2-3 per CC	≥8
8	4x20	3x20	20	As defined in Table 8.2.3.1.2-2 and Table 8.2.3.1.2-3 per CC	≥8
9	10+3x20	10	3x20	As defined in Table 8.2.3.1.2-2 and Table 8.2.3.1.2-3 per CC	≥8
10	2x10+2x20	2x10	2x20	As defined in Table 8.2.3.1.2-2 and Table 8.2.3.1.2-3 per CC	≥8
11	2x10+20+15	2x10	20+15	As defined in Table 8.2.3.1.2-2 and Table 8.2.3.1.2-3 per CC	≥8
12	10+3x20	10+20	2x20	As defined in Table 8.2.3.1.2-2 and Table 8.2.3.1.2-3 per CC	≥8
13	10+15+2x20	10+15	2x20	As defined in Table 8.2.3.1.2-2 and Table 8.2.3.1.2-3 per CC	≥8
14	10+15+2x20	10+15+20	20	As defined in Table 8.2.3.1.2-2 and Table 8.2.3.1.2-3 per CC	≥8
Note 1:	The applicability of requirements for different CA configurations and bandwidth combination sets is defined in 8.1.2.3B.				
Note 2:	30usec timing difference between PCell and any SCell is applied in inter-band CA case, where PCell can be assigned on any CC.				

**Table 8.2.3.1.2-7: Minimum performance for multiple CA configurations with 5DL CCs (FRC)**

Test number	Aggregated Bandwidth (MHz)			Minimum performance requirement	UE Category
	Total	FDD CC	TDD CC		
1	15+4x20	15+2x20	2x20	As defined in Table 8.2.3.1.2-2 and Table 8.2.3.1.2-3 per CC	8, ≥11
2	2x15+3x20	2x15+20	2x20	As defined in Table 8.2.3.1.2-2 and Table 8.2.3.1.2-3 per CC	8, ≥11
3	4x20+20	4x20	20	As defined in Table 8.2.3.1.2-2 and Table 8.2.3.1.2-3 per CC	8, ≥11
4	3x20+2x20	3x20	2x20	As defined in Table 8.2.3.1.2-2 and Table 8.2.3.1.2-3 per CC	8, ≥11
5	2x20+3x20	2x20	3x20	As defined in Table 8.2.3.1.2-2 and Table 8.2.3.1.2-3 per CC	8, ≥11
6	20+4x20	20	4x20	As defined in Table 8.2.3.1.2-2 and Table 8.2.3.1.2-3 per CC	8, ≥11
7	10+4x20	10	4x20	As defined in Table 8.2.3.1.2-2 and Table 8.2.3.1.2-3 per CC	8, ≥11
8	10+20+3x20	10+20	3x20	As defined in Table 8.2.3.1.2-2 and Table 8.2.3.1.2-3 per CC	8, ≥11
9	2x10+3x20	2x10	3x20	As defined in Table 8.2.3.1.2-2 and Table 8.2.3.1.2-3 per CC	8, ≥11
10	10+2x20+2x20	10+2x20	2x20	As defined in Table 8.2.3.1.2-2 and Table 8.2.3.1.2-3 per CC	8, ≥11
11	10+15+20+2x20	10+15+20	2x20	As defined in Table 8.2.3.1.2-2 and Table 8.2.3.1.2-3 per CC	8, ≥11

Note 1: The applicability of requirements for different CA configurations and bandwidth combination sets is defined in 8.1.2.3B.

Note 2: 30usec timing difference between PCell and any SCell is applied in inter-band CA case, where PCell can be assigned on any CC.

**Table 8.2.3.1.2-8: Minimum performance for multiple CA configurations with 6DL CCs (FRC)**

Test number	CA Bandwidth combination (MHz)			Minimum performance requirement	UE Category
	Total	FDD CC	TDD CC		
1	1x20+5x20	1x20	5x20	As defined in Table 8.2.3.1.1-2 and Table 8.2.3.1.1-3 per CC	8, ≥11
2	2x20+4x20	2x20	4x20	As defined in Table 8.2.3.1.1-2 and Table 8.2.3.1.1-3 per CC	8, ≥11

**Table 8.2.3.1.2-9: Minimum performance for multiple CA configurations with 7DL CCs (FRC)**

Test number	CA Bandwidth combination (MHz)			Minimum performance requirement	UE Category
	Total	FDD CC	TDD CC		
1	1x20+6x20	1x20	6x20	As defined in Table 8.2.3.1.1-2 and Table 8.2.3.1.1-3 per CC	8, ≥11
2	2x20+5x20	2x20	5x20	As defined in Table 8.2.3.1.1-2 and Table 8.2.3.1.1-3 per CC	8, ≥11

## 8.2.3.2 Open-loop spatial multiplexing performance 2Tx Antenna port

### 8.2.3.2.1 Minimum Requirement for FDD PCell

For TDD FDD CA with FDD PCell and 2DL CCs, the requirements are specified in Table 8.2.3.2.1-4 based on single carrier requirement specified in Table 8.2.3.2.1-2 and Table 8.2.3.2.1-3, with the addition of the parameters in Table 8.2.3.2.1-1 and the downlink physical channel setup according to Annex C.3.2. The purpose is to verify the performance of large delay CDD with 2 transmitter antennas.

For TDD FDD CA with FDD PCell and 3DL CCs, the requirements are specified in Table 8.2.3.2.1-5 based on single carrier requirement specified in Table 8.2.3.2.1-2 and Table 8.2.3.2.1-3, with the addition of the parameters in Table 8.2.3.2.1-1 and the downlink physical channel setup according to Annex C.3.2. The purpose is to verify the performance of large delay CDD with 2 transmitter antennas.

For TDD FDD CA with FDD PCell and 4DL CCs, the requirements are specified in Table 8.2.3.2.1-6 based on single carrier requirement specified in Table 8.2.3.2.1-2 and Table 8.2.3.2.1-3, with the addition of the parameters in Table 8.2.3.2.1-1 and the downlink physical channel setup according to Annex C.3.2. The purpose is to verify the performance of large delay CDD with 2 transmitter antennas.

For TDD FDD CA with FDD PCell and 5DL CCs, the requirements are specified in Table 8.2.3.2.1-7 based on single carrier requirement specified in Table 8.2.3.2.1-2 and Table 8.2.3.2.1-3, with the addition of the parameters in Table 8.2.3.2.1-1 and the downlink physical channel setup according to Annex C.3.2. The purpose is to verify the performance of large delay CDD with 2 transmitter antennas.

For TDD FDD CA with FDD PCell and 6DL CCs, the requirements are specified in Table 8.2.3.2.1-8 based on single carrier requirement specified in Table 8.2.3.2.1-2 and Table 8.2.3.2.1-3, with the addition of the parameters in Table 8.2.3.2.1-1 and the downlink physical channel setup according to Annex C.3.2. The purpose is to verify the performance of large delay CDD with 2 transmitter antennas.

For TDD FDD CA with FDD PCell and 7DL CCs, the requirements are specified in Table 8.2.3.2.1-9 based on single carrier requirement specified in Table 8.2.3.2.1-2 and Table 8.2.3.2.1-3, with the addition of the parameters in Table 8.2.3.2.1-1 and the downlink physical channel setup according to Annex C.3.2. The purpose is to verify the performance of large delay CDD with 2 transmitter antennas.

The test coverage for different number of component carriers is defined in 8.1.2.4.

**Table 8.2.3.2.1-1: Test Parameters for Large Delay CDD (FRC) for CA**

Parameter	Unit	Value	
Downlink power allocation	$\rho_A$	dB	-3
	$\rho_B$	dB	-3 (Note 1)
	$\sigma$	dB	0
$N_{oc}$ at antenna port	dBm/15kHz	-98	
PDSCH transmission mode		3	
Note 1: $P_B = 1$ .			
Note 2: The same PDSCH transmission mode is applied to each component carrier.			

**Table 8.2.3.2.1-2: Single carrier performance with different bandwidths for multiple CA configurations for FDD PCell and SCell (FRC)**

Bandwidth	Reference Channel	OCNG Pattern	Propagation Condition	Correlation Matrix and Antenna Configuration	Reference value	
					Fraction of Maximum Throughput (%)	SNR (dB)
1.4 MHz	R.11-5 FDD	OP.1 FDD	EVA70	2x2 Low	70	13.6
3 MHz	R.11-6 FDD	OP.1 FDD	EVA70	2x2 Low	70	12.3
5MHz	R.11-2 FDD	OP.1 FDD	EVA70	2x2 Low	70	12.3
10MHz	R.11 FDD	OP.1 FDD	EVA70	2x2 Low	70	12.9
15MHz	R.11-7 FDD	OP.1 FDD	EVA70	2x2 Low	70	12.8
20MHz	R.30 FDD	OP.1 FDD	EVA70	2x2 Low	70	12.9

**Table 8.2.3.2.1-3: Single carrier performance with different bandwidths for multiple CA configurations for TDD SCell (FRC)**

Bandwidth	Reference Channel	OCNG Pattern	Propagation Condition	Correlation Matrix and Antenna Configuration	Reference value	
					Fraction of Maximum Throughput (%)	SNR (dB)
1.4 MHz	R.11-5 TDD	OP.1 TDD	EVA70	2x2 Low	70	13.2
3 MHz	R.11-6 TDD	OP.1 TDD	EVA70	2x2 Low	70	12.8
5MHz	R.11-7 TDD	OP.1 TDD	EVA70	2x2 Low	70	12.6
10MHz	R.11-8 TDD	OP.1 TDD	EVA70	2x2 Low	70	12.8
15MHz	R.11-9 TDD	OP.1 TDD	EVA70	2x2 Low	70	12.9
20MHz	R.30-1 TDD	OP.1 TDD	EVA70	2x2 Low	70	13.0

**Table 8.2.3.2.1-4: Minimum performance for multiple CA configurations with 2DL CCs (FRC)**

Test number	Aggregated Bandwidth (MHz)			Minimum performance requirement	UE Category
	Total	FDD CC	TDD CC		
1	2x20	20	20	As defined in Table 8.2.3.2.1-2 and Table 8.2.3.2.1-3 per CC	≥5
2	20+10	10	20	As defined in Table 8.2.3.2.1-2 and Table 8.2.3.2.1-3 per CC	≥5
3	20+15	15	20	As defined in Table 8.2.3.2.1-2 and Table 8.2.3.2.1-3 per CC	≥5

Note 1: The applicability of requirements for different CA configurations and bandwidth combination sets is defined in 8.1.2.3B

**Table 8.2.3.2.1-5: Minimum performance for multiple CA configurations with 3DL CCs (FRC)**

Test number	Aggregated Bandwidth (MHz)			Minimum performance requirement	UE Category
	Total	FDD CC	TDD CC		
1	3x20	20	2x20	As defined in Table 8.2.3.2.1-2 and Table 8.2.3.2.1-3 per CC	≥5
2	20+20+15	15	2x20	As defined in Table 8.2.3.2.1-2 and Table 8.2.3.2.1-3 per CC	≥5
3	20+20+10	10	2x20	As defined in Table 8.2.3.2.1-2 and Table 8.2.3.2.1-3 per CC	≥5
4	3x20	2x20	20	As defined in Table 8.2.3.2.1-2 and Table 8.2.3.2.1-3 per CC	≥5
5	20+20+15	20+15	20	As defined in Table 8.2.3.2.1-2 and Table 8.2.3.2.1-3 per CC	≥5
6	20+20+10	20+10	20	As defined in Table 8.2.3.2.1-2 and Table 8.2.3.2.1-3 per CC	≥5
7	20+10+10	2x10	20	As defined in Table 8.2.3.2.1-2 and Table 8.2.3.1.1-3 per CC	≥5
8	10+15+20	10	15+20	As defined in Table 8.2.3.2.1-2 and Table 8.2.3.2.1-3 per CC	≥5
9	10+15+20	10+15	20	As defined in Table 8.2.3.2.1-2 and Table 8.2.3.1.1-3 per CC	≥5

Note 1: The applicability of requirements for different CA configurations and bandwidth combination sets is defined in 8.1.2.3B.

Table 8.2.3.2.1-6: Minimum performance for multiple CA configurations with 4DL CCs (FRC)

Test number	Aggregated Bandwidth (MHz)			Minimum performance requirement	UE Category
	Total	FDD CC	TDD CC		
1	4x20	20	3x20	As defined in Table 8.2.3.2.1-2 and Table 8.2.3.2.1-3 per CC	≥8
2	4x20	2x20	2x20	As defined in Table 8.2.3.2.1-2 and Table 8.2.3.2.1-3 per CC	≥8
3	3x20+15	20+15	2x20	As defined in Table 8.2.3.2.1-2 and Table 8.2.3.2.1-3 per CC	≥8
4	2x15+2x20	2x15	2x20	As defined in Table 8.2.3.2.1-2 and Table 8.2.3.2.1-3 per CC	≥8
5	3x20+15	2x20+15	20	As defined in Table 8.2.3.2.1-2 and Table 8.2.3.2.1-3 per CC	≥8
6	2x15+2x20	2x15+20	20	As defined in Table 8.2.3.2.1-2 and Table 8.2.3.2.1-3 per CC	≥8
7	3x20+10	2x20+10	20	As defined in Table 8.2.3.2.1-2 and Table 8.2.3.2.1-3 per CC	≥8
8	4x20	3x20	20	As defined in Table 8.2.3.2.1-2 and Table 8.2.3.2.1-3 per CC	≥8
9	10+3x20	10	3x20	As defined in Table 8.2.3.2.1-2 and Table 8.2.3.2.1-3 per CC	≥8
10	2x10+2x20	2x10	2x20	As defined in Table 8.2.3.2.1-2 and Table 8.2.3.2.1-3 per CC	≥8
11	2x10+20+15	2x10	20+15	As defined in Table 8.2.3.2.1-2 and Table 8.2.3.2.1-3 per CC	≥8
12	10+3x20	10+20	2x20	As defined in Table 8.2.3.2.1-2 and Table 8.2.3.2.1-3 per CC	≥8
13	10+15+2x20	10+15	2x20	As defined in Table 8.2.3.2.1-2 and Table 8.2.3.2.1-3 per CC	≥8
14	10+15+2x20	10+15+20	20	As defined in Table 8.2.3.2.1-2 and Table 8.2.3.2.1-3 per CC	≥8

Note 1: The applicability of requirements for different CA configurations and bandwidth combination sets is defined in 8.1.2.3B.

Table 8.2.3.2.1-7: Minimum performance for multiple CA configurations with 5DL CCs (FRC)

Test number	Aggregated Bandwidth (MHz)			Minimum performance requirement	UE Category
	Total	FDD CC	TDD CC		
1	15+4x20	15+2x20	2x20	As defined in Table 8.2.3.1.2-2 and Table 8.2.3.1.2-3 per CC	8, ≥11
2	2x15+3x20	2x15+20	2x20	As defined in Table 8.2.3.1.2-2 and Table 8.2.3.1.2-3 per CC	8, ≥11
3	4x20+20	4x20	20	As defined in Table 8.2.3.2.1-2 and Table 8.2.3.2.1-3 per CC	8, ≥11
4	3x20+2x20	3x20	2x20	As defined in Table 8.2.3.2.1-2 and Table 8.2.3.2.1-3 per CC	8, ≥11
5	2x20+3x20	2x20	3x20	As defined in Table 8.2.3.2.1-2 and Table 8.2.3.2.1-3 per CC	8, ≥11
6	20+4x20	20	4x20	As defined in Table 8.2.3.2.1-2 and Table 8.2.3.2.1-3 per CC	8, ≥11
7	10+4x20	10	4x20	As defined in Table 8.2.3.2.1-2 and Table 8.2.3.2.1-3 per CC	8, ≥11
8	10+20+3x20	10+20	3x20	As defined in Table 8.2.3.2.1-2 and Table 8.2.3.2.1-3 per CC	8, ≥11
9	2x10+3x20	2x10	3x20	As defined in Table 8.2.3.2.1-2 and Table 8.2.3.2.1-3 per CC	8, ≥11
10	10+2x20+2x20	10+2x20	2x20	As defined in Table 8.2.3.2.1-2 and Table 8.2.3.2.1-3 per CC	8, ≥11
11	10+15+20+2x20	10+15+20	2x20	As defined in Table 8.2.3.2.1-2 and Table 8.2.3.2.1-3 per CC	8, ≥11

Note 1: The applicability of requirements for different CA configurations and bandwidth combination sets is defined in 8.1.2.3B.

Table 8.2.3.2.1-8: Minimum performance for multiple CA configurations with 6DL CCs (FRC)

Test number	CA Bandwidth combination (MHz)			Minimum performance requirement	UE Category
	Total	FDD CC	TDD CC		
1	1x20+5x20	1x20	5x20	As defined in Table 8.2.3.2.1-2 and Table 8.2.3.2.1-3 per CC	8, ≥11
2	2x20+4x20	2x20	4x20	As defined in Table 8.2.3.2.1-2 and Table 8.2.3.2.1-3 per CC	8, ≥11

Table 8.2.3.2.1-9: Minimum performance for multiple CA configurations with 7DL CCs (FRC)

Test number	CA Bandwidth combination (MHz)			Minimum performance requirement	UE Category
	Total	FDD CC	TDD CC		
1	1x20+6x20	1x20	6x20	As defined in Table 8.2.3.2.1-2 and Table 8.2.3.2.1-3 per CC	8, ≥11
2	2x20+5x20	2x20	5x20	As defined in Table 8.2.3.2.1-2 and Table 8.2.3.2.1-3 per CC	8, ≥11

#### 8.2.3.2.1A Soft buffer management test for FDD PCell

For TDD-FDD CA, the requirements are specified in Table 8.2.3.2.1A-2, with the addition of the parameters in Table 8.2.3.2.1A-1 and the downlink physical channel setup according to Annex C.3.2. The purpose is to verify the UE performance with proper instantaneous buffer implementation for FDD as PCell.



Table 8.2.3.2.1A-1: Test Parameters for CA

Parameter	Unit	Value		
		FDD Carrier	TDD Carrier	
Downlink power allocation	$\rho_A$	dB	-3	-3
	$\rho_B$	dB	-3 (Note 1)	-3 (Note 1)
	$\sigma$	dB	0	0
$N_{oc}$ at antenna port	dBm/15kHz	-98	-98	-98
PDSCH transmission mode		3	3	3

Note 1:  $P_B = 1$ .

Note 2: The same PDSCH transmission mode is applied to each component carrier.

Table 8.2.3.2.1A-2: Minimum performance (FRC) for CA

Test num.	Band-width		Reference channel	OCNG pattern	Propagation condition	Correlation matrix and antenna config	Reference value		UE category
							Fraction of maximum throughput (%)	SNR (dB)	
1	PCell	20MHz	R.30 FDD	OP.1 FDD (Note 1)	EVA70	2x2 Low	70	13.2	3
	SCell	20MHz	R.30-2 TDD	OP.1 TDD (Note 1)			70	13.2	
2	PCell	20MHz	R.35-1 FDD	OP.1 FDD (Note 1)	EVA70	2x2 Low	70	16.3	4
	SCell	20MHz	R.35-1 TDD	OP.1 TDD (Note 1)			70	16.3	
3	PCell	10MHz	R.35-3 FDD	OP.1 FDD (Note 1)	EVA70	2x2 Low	70	16.0	3
	SCell	20MHz	R.30-2 TDD	OP.1 TDD (Note 1)			70	13.2	
4	PCell	10MHz	R.35-3 FDD	OP.1 FDD (Note 1)	EVA70	2x2 Low	70	16.0	4
	SCell	20MHz	R.35-1 TDD	OP.1 TDD (Note 1)			70	16.3	
5	PCell	15MHz	R.35-2 FDD	OP.1 FDD (Note 1)	EVA70	2x2 Low	70	16.0	3
	SCell	20MHz	R.30-2 TDD	OP.1 TDD (Note 1)			70	13.2	
6	PCell	15MHz	R.35-2 FDD	OP.1 FDD (Note 1)	EVA70	2x2 Low	70	16.0	4
	SCell	20MHz	R.35-1 TDD	OP.1 TDD (Note 1)			70	16.3	

Note 1: The OCNG pattern applies for each CC.

Note 2: The applicability and test rules of requirements for different CA configurations and bandwidth combination sets are defined in 8.1.2.3B.

### 8.2.3.2.2 Minimum Requirement for TDD PCell

For TDD FDD CA with TDD PCell and 2DL CCs, the requirements are specified in Table 8.2.3.2.2-4 based on single carrier requirement specified in Table 8.2.3.2.2-2 and Table 8.2.3.2.2-3, with the addition of the parameters in Table 8.2.3.2.2-1 and the downlink physical channel setup according to Annex C.3.2. The purpose is to verify the performance of large delay CDD with 2 transmitter antennas.

For TDD FDD CA with TDD PCell and 3DL CCs, the requirements are specified in Table 8.2.3.2.2-5 based on single carrier requirement specified in Table 8.2.3.2.2-2 and Table 8.2.3.2.2-3, with the addition of the parameters in Table 8.2.3.2.2-1 and the downlink physical channel setup according to Annex C.3.2. The purpose is to verify the performance of large delay CDD with 2 transmitter antennas.

For TDD FDD CA with TDD PCell and 4DL CCs, the requirements are specified in Table 8.2.3.2.2-6 based on single carrier requirement specified in Table 8.2.3.2.2-2 and Table 8.2.3.2.2-3, with the addition of the parameters in Table 8.2.3.2.2-1 and the downlink physical channel setup according to Annex C.3.2. The purpose is to verify the performance of large delay CDD with 2 transmitter antennas.

For TDD FDD CA with TDD PCell and 5DL CCs, the requirements are specified in Table 8.2.3.2.2-7 based on single carrier requirement specified in Table 8.2.3.2.2-2 and Table 8.2.3.2.2-3, with the addition of the parameters in Table 8.2.3.2.2-1 and the downlink physical channel setup according to Annex C.3.2. The purpose is to verify the performance of large delay CDD with 2 transmitter antennas.

For TDD FDD CA with TDD PCell and 6DL CCs, the requirements are specified in Table 8.2.3.2.2-8 based on single carrier requirement specified in Table 8.2.3.2.2-2 and Table 8.2.3.2.2-3, with the addition of the parameters in Table 8.2.3.2.2-1 and the downlink physical channel setup according to Annex C.3.2. The purpose is to verify the performance of large delay CDD with 2 transmitter antennas.

For TDD FDD CA with TDD PCell and 7DL CCs, the requirements are specified in Table 8.2.3.2.2-9 based on single carrier requirement specified in Table 8.2.3.2.2-2 and Table 8.2.3.2.2-3, with the addition of the parameters in Table 8.2.3.2.2-1 and the downlink physical channel setup according to Annex C.3.2. The purpose is to verify the performance of large delay CDD with 2 transmitter antennas.

The test coverage for different number of component carriers is defined in 8.1.2.4.

**Table 8.2.3.2.2-1: Test Parameters for Large Delay CDD (FRC) for CA**

Parameter	Unit	Value	
Downlink power allocation	$\rho_A$	dB	-3
	$\rho_B$	dB	-3 (Note 1)
	$\sigma$	dB	0
$N_{oc}$ at antenna port	dBm/15kHz	-98	
PDSCH transmission mode		3	
Note 1: $P_B = 1$ .			
Note 2: The same PDSCH transmission mode is applied to each component carrier.			

**Table 8.2.3.2.2-2: Single carrier performance with different bandwidths for multiple CA configurations for FDD SCell (FRC)**

Bandwidth	Reference Channel	OCNG Pattern	Propagation Condition	Correlation Matrix and Antenna Configuration	Reference value	
					Fraction of Maximum Throughput (%)	SNR (dB)
1.4 MHz	R.11-5 FDD	OP.1 FDD	EVA70	2x2 Low	70	13.6
3 MHz	R.11-6 FDD	OP.1 FDD	EVA70	2x2 Low	70	12.3
5MHz	R.11-2 FDD	OP.1 FDD	EVA70	2x2 Low	70	12.3
10MHz	R.11 FDD	OP.1 FDD	EVA70	2x2 Low	70	12.9
15MHz	R.11-7 FDD	OP.1 FDD	EVA70	2x2 Low	70	12.8
20MHz	R.30 FDD	OP.1 FDD	EVA70	2x2 Low	70	12.9

**Table 8.2.3.2.2-3: Single carrier performance with different bandwidths for multiple CA configurations for TDD PCell and SCell (FRC)**

Bandwidth	Reference Channel	OCNG Pattern	Propagation Condition	Correlation Matrix and Antenna Configuration	Reference value	
					Fraction of Maximum Throughput (%)	SNR (dB)
1.4 MHz	R.11-5 TDD	OP.1 TDD	EVA70	2x2 Low	70	13.2
3 MHz	R.11-6 TDD	OP.1 TDD	EVA70	2x2 Low	70	12.8
5MHz	R.11-7 TDD	OP.1 TDD	EVA70	2x2 Low	70	12.6
10MHz	R.11-8 TDD	OP.1 TDD	EVA70	2x2 Low	70	12.8
15MHz	R.11-9 TDD	OP.1 TDD	EVA70	2x2 Low	70	12.9
20MHz	R.30-1 TDD	OP.1 TDD	EVA70	2x2 Low	70	13.0

**Table 8.2.3.2.2-4: Minimum performance for multiple CA configurations with 2DL CCs (FRC)**

Test number	Aggregated Bandwidth (MHz)			Minimum performance requirement	UE Category
	Total	FDD CC	TDD CC		
1	2x20	20	20	As defined in Table 8.2.3.2.2-2 and Table 8.2.3.2.2-3 per CC	≥5
2	20+10	10	20	As defined in Table 8.2.3.2.2-2 and Table 8.2.3.2.2-3 per CC	≥5
3	20+15	15	20	As defined in Table 8.2.3.2.2-2 and Table 8.2.3.2.2-3 per CC	≥5

Note 1: The applicability of requirements for different CA configurations and bandwidth combination sets is defined in 8.1.2.3B

**Table 8.2.3.2.2-5: Minimum performance for multiple CA configurations with 3DL CCs (FRC)**

Test number	Aggregated Bandwidth (MHz)			Minimum performance requirement	UE Category
	Total	FDD CC	TDD CC		
1	3x20	20	2x20	As defined in Table 8.2.3.2.2-2 and Table 8.2.3.2.2-3 per CC	≥5
2	20+20+15	15	2x20	As defined in Table 8.2.3.2.2-2 and Table 8.2.3.2.2-3 per CC	≥5
3	20+20+10	10	2x20	As defined in Table 8.2.3.2.2-2 and Table 8.2.3.2.2-3 per CC	≥5
4	3x20	2x20	20	As defined in Table 8.2.3.2.2-2 and Table 8.2.3.2.2-3 per CC	≥5
5	20+20+15	20+15	20	As defined in Table 8.2.3.2.2-2 and Table 8.2.3.2.2-3 per CC	≥5
6	20+20+10	20+10	20	As defined in Table 8.2.3.2.2-2 and Table 8.2.3.2.2-3 per CC	≥5
7	20+10+10	2x10	20	As defined in Table 8.2.3.2.2-2 and Table 8.2.3.2.2-3 per CC	≥5
8	10+15+20	10	15+20	As defined in Table 8.2.3.2.2-2 and Table 8.2.3.2.2-3 per CC	≥5
9	10+15+20	10+15	20	As defined in Table 8.2.3.2.2-2 and Table 8.2.3.2.2-3 per CC	≥5

Note 1: The applicability of requirements for different CA configurations and bandwidth combination sets is defined in 8.1.2.3B.

Table 8.2.3.2.2-6: Minimum performance for multiple CA configurations with 4DL CCs (FRC)

Test number	Aggregated Bandwidth (MHz)			Minimum performance requirement	UE Category
	Total	FDD CC	TDD CC		
1	4x20	20	3x20	As defined in Table 8.2.3.2.2-2 and Table 8.2.3.2.2-3 per CC	≥8
2	4x20	2x20	2x20	As defined in Table 8.2.3.2.2-2 and Table 8.2.3.2.2-3 per CC	≥8
3	3x20+15	20+15	2x20	As defined in Table 8.2.3.2.2-2 and Table 8.2.3.2.2-3 per CC	≥8
4	2x15+2x20	2x15	2x20	As defined in Table 8.2.3.2.2-2 and Table 8.2.3.2.2-3 per CC	≥8
5	3x20+15	2x20+15	20	As defined in Table 8.2.3.2.2-2 and Table 8.2.3.2.2-3 per CC	≥8
6	2x15+2x20	2x15+20	20	As defined in Table 8.2.3.2.2-2 and Table 8.2.3.2.2-3 per CC	≥8
7	3x20+10	2x20+10	20	As defined in Table 8.2.3.2.2-2 and Table 8.2.3.2.2-3 per CC	≥8
8	4x20	3x20	20	As defined in Table 8.2.3.2.2-2 and Table 8.2.3.2.2-3 per CC	≥8
9	10+3x20	10	3x20	As defined in Table 8.2.3.2.2-2 and Table 8.2.3.2.2-3 per CC	≥8
10	2x10+2x20	2x10	2x20	As defined in Table 8.2.3.2.2-2 and Table 8.2.3.2.2-3 per CC	≥8
11	2x10+20+15	2x10	20+15	As defined in Table 8.2.3.2.2-2 and Table 8.2.3.2.2-3 per CC	≥8
12	10+3x20	10+20	2x20	As defined in Table 8.2.3.2.2-2 and Table 8.2.3.2.2-3 per CC	≥8
13	10+15+2x20	10+15	2x20	As defined in Table 8.2.3.2.2-2 and Table 8.2.3.2.2-3 per CC	≥8
14	10+15+2x20	10+15+20	20	As defined in Table 8.2.3.2.2-2 and Table 8.2.3.2.2-3 per CC	≥8

Note 1: The applicability of requirements for different CA configurations and bandwidth combination sets is defined in 8.1.2.3B.

Table 8.2.3.2.2-7: Minimum performance for multiple CA configurations with 5DL CCs (FRC)

Test number	Aggregated Bandwidth (MHz)			Minimum performance requirement	UE Category
	Total	FDD CC	TDD CC		
1	15+4x20	15+2x20	2x20	As defined in Table 8.2.3.2.2-2 and Table 8.2.3.2.2-3 per CC	8, ≥11
2	2x15+3x20	2x15+20	2x20	As defined in Table 8.2.3.2.2-2 and Table 8.2.3.2.2-3 per CC	8, ≥11
3	4x20+20	4x20	20	As defined in Table 8.2.3.2.2-2 and Table 8.2.3.2.2-3 per CC	8, ≥11
4	3x20+2x20	3x20	2x20	As defined in Table 8.2.3.2.2-2 and Table 8.2.3.2.2-3 per CC	8, ≥11
5	2x20+3x20	2x20	3x20	As defined in Table 8.2.3.2.2-2 and Table 8.2.3.2.2-3 per CC	8, ≥11
6	20+4x20	20	4x20	As defined in Table 8.2.3.2.2-2 and Table 8.2.3.2.2-3 per CC	8, ≥11
7	10+4x20	10	4x20	As defined in Table 8.2.3.2.2-2 and Table 8.2.3.2.2-3 per CC	8, ≥11
8	10+20+3x20	10+20	3x20	As defined in Table 8.2.3.2.2-2 and Table 8.2.3.2.2-3 per CC	8, ≥11
9	2x10+3x20	2x10	3x20	As defined in Table 8.2.3.2.2-2 and Table 8.2.3.2.2-3 per CC	8, ≥11
10	10+2x20+2x20	10+2x20	2x20	As defined in Table 8.2.3.2.2-2 and Table 8.2.3.2.2-3 per CC	8, ≥11
11	10+15+20+2x20	10+15+20	2x20	As defined in Table 8.2.3.2.2-2 and Table 8.2.3.2.2-3 per CC	8, ≥11

Note 1: The applicability of requirements for different CA configurations and bandwidth combination sets is defined in 8.1.2.3B.

Table 8.2.3.2.2-8: Minimum performance for multiple CA configurations with 6DL CCs (FRC)

Test number	CA Bandwidth combination (MHz)			Minimum performance requirement	UE Category
	Total	FDD CC	TDD CC		
1	1x20+5x20	1x20	5x20	As defined in Table 8.2.3.1.1-2 and Table 8.2.3.1.1-3 per CC	8, ≥11
2	2x20+4x20	2x20	4x20	As defined in Table 8.2.3.1.1-2 and Table 8.2.3.1.1-3 per CC	8, ≥11

Table 8.2.3.2.2-9: Minimum performance for multiple CA configurations with 7DL CCs (FRC)

Test number	CA Bandwidth combination (MHz)			Minimum performance requirement	UE Category
	Total	FDD CC	TDD CC		
1	1x20+6x20	1x20	6x20	As defined in Table 8.2.3.1.1-2 and Table 8.2.3.1.1-3 per CC	8, ≥11
2	2x20+5x20	2x20	5x20	As defined in Table 8.2.3.1.1-2 and Table 8.2.3.1.1-3 per CC	8, ≥11

#### 8.2.3.2.2A Soft buffer management test for TDD PCell

For TDD-FDD CA, the requirements are specified in Table 8.2.3.2.2A-2, with the addition of the parameters in Table 8.2.3.2.2A-1 and the downlink physical channel setup according to Annex C.3.2. The purpose is to verify the UE performance with proper instantaneous buffer implementation for TDD as PCell.

Table 8.2.3.2.2A-1: Test Parameters for CA

Parameter	Unit	Value		
		FDD Carrier	TDD Carrier	
Downlink power allocation	$\rho_A$	dB	-3	-3
	$\rho_B$	dB	-3 (Note 1)	-3 (Note 1)
	$\sigma$	dB	0	0
$N_{oc}$ at antenna port	dBm/15kHz	-98	-98	-98
PDSCH transmission mode		3	3	3

Note 1:  $P_B = 1$ .

Note 2: The same PDSCH transmission mode is applied to each component carrier.

Table 8.2.3.2.2A-2: Minimum performance (FRC) for CA

Test num.	Band-width		Reference channel	OCNG pattern	Propagation condition	Correlation matrix and antenna config	Reference value		UE category
							Fraction of maximum throughput (%)	SNR (dB)	
1	PCell	20MHz	R.30-2 TDD	OP.1 TDD (Note 1))	EVA70	2x2 Low	70	13.2	3
	SCell	20MHz	R.30 FDD	OP.1 FDD (Note 1)			70	13.2	
2	PCell	20MHz	R.35-1 TDD	OP.1 TDD (Note 1)	EVA70	2x2 Low	70	16.2	4
	SCell	20MHz	R.35-1 FDD	OP.1 FDD (Note 1)			70	16.2	
3	PCell	20MHz	R.30-2 TDD	OP.1 TDD (Note 1)	EVA70	2x2 Low	70	13.2	3
	SCell	10MHz	R.35-3 FDD	OP.1 FDD (Note 1)			70	16.0	
4	PCell	20MHz	R.35-1 TDD	OP.1 TDD (Note 1)	EVA70	2x2 Low	70	16.2	4
	SCell	10MHz	R.35-3 FDD	OP.1 FDD (Note 1)			70	15.8	
5	PCell	20MHz	R.30-2 TDD	OP.1 TDD (Note 1)	EVA70	2x2 Low	70	13.2	3
	SCell	15MHz	R.35-2 FDD	OP.1 FDD (Note 1)			70	15.8	
6	PCell	20MHz	R.35-1 TDD	OP.1 TDD (Note 1)	EVA70	2x2 Low	70	16.2	4
	SCell	15MHz	R.35-2 FDD	OP.1 FDD (Note 1)			70	15.8	

Note 1: The OCNG pattern applies for each CC.

Note 2: The applicability and test rules of requirements for different CA configurations and bandwidth combination sets are defined in 8.1.2.3B.

### 8.2.3.3 Closed-loop spatial multiplexing performance 4Tx Antenna Port

#### 8.2.3.3.1 Minimum Requirement for FDD PCell

For TDD FDD CA with FDD PCell and 2DL CCs, the requirements are specified in Table 8.2.3.3.1-4 based on single carrier requirement specified in Table 8.2.3.3.1-2 and Table 8.2.3.3.1-3, with the addition of the parameters in Table 8.2.3.3.1-1 and the downlink physical channel setup according to Annex C.3.2. The purpose of these tests is to verify the closed loop rank-two performance with wideband and frequency selective precoding.

For TDD FDD CA with FDD PCell and 3DL CCs, the requirements are specified in Table 8.2.3.3.1-5 based on single carrier requirement specified in Table 8.2.3.3.1-2 and Table 8.2.3.3.1-3, with the addition of the parameters in Table

8.2.3.3.1-1 and the downlink physical channel setup according to Annex C.3.2. The purpose of these tests is to verify the closed loop rank-two performance with wideband and frequency selective precoding.

For TDD FDD CA with FDD PCell and 4DL CCs, the requirements are specified in Table 8.2.3.3.1-6 based on single carrier requirement specified in Table 8.2.3.3.1-2 and Table 8.2.3.3.1-3, with the addition of the parameters in Table 8.2.3.3.1-1 and the downlink physical channel setup according to Annex C.3.2. The purpose of these tests is to verify the closed loop rank-two performance with wideband and frequency selective precoding.

For TDD FDD CA with FDD PCell and 5DL CCs, the requirements are specified in Table 8.2.3.3.1-7 based on single carrier requirement specified in Table 8.2.3.3.1-2 and Table 8.2.3.3.1-3, with the addition of the parameters in Table 8.2.3.3.1-1 and the downlink physical channel setup according to Annex C.3.2. The purpose of these tests is to verify the closed loop rank-two performance with wideband and frequency selective precoding.

For TDD FDD CA with FDD PCell and 6DL CCs, the requirements are specified in Table 8.2.3.3.1-8 based on single carrier requirement specified in Table 8.2.3.3.1-2 and Table 8.2.3.3.1-3, with the addition of the parameters in Table 8.2.3.3.1-1 and the downlink physical channel setup according to Annex C.3.2. The purpose of these tests is to verify the closed loop rank-two performance with wideband and frequency selective precoding.

For TDD FDD CA with FDD PCell and 7DL CCs, the requirements are specified in Table 8.2.3.3.1-9 based on single carrier requirement specified in Table 8.2.3.3.1-2 and Table 8.2.3.3.1-3, with the addition of the parameters in Table 8.2.3.3.1-1 and the downlink physical channel setup according to Annex C.3.2. The purpose of these tests is to verify the closed loop rank-two performance with wideband and frequency selective precoding.

The test coverage for different number of component carriers is defined in 8.1.2.4.

**Table 8.2.3.3.1-1: Test Parameters for Multi-Layer Spatial Multiplexing (FRC) for CA**

Parameter		Unit	Value
Downlink power allocation	$\rho_A$	dB	-6
	$\rho_B$	dB	-6 (Note 1)
	$\sigma$	dB	3
$N_{oc}$ at antenna port		dBm/15kHz	-98
Precoding granularity		PRB	Wideband precoding for 1.4MHz, 4 for 3MHz and 5MHz CCs, 6 for 10MHz CCs, 8 for 15MHz and 20MHz CCs
PMI delay (Note 2)	FDD CC	ms	8
	TDD CC	ms	10 or 11
Reporting interval	FDD CC	ms	1
	TDD CC	ms	1 or 4 (Note 3)
Reporting mode			PUSCH 1-2
CodeBookSubsetRestriction bitmap			00000000000000000000000000000000 0000111111111111111111111100000000 00000000
CSI request field (Note 3)			'10'
PDSCH transmission mode			4
Note 1: $P_B = 1$ .			
Note 2: If the UE reports in an available uplink reporting instance at subframe SF#n based on PMI estimation at a downlink SF not later than SF#(n-4), this reported PMI cannot be applied at the eNB downlink before SF#(n+4).			
Note 3: Multiple CC-s under test are configured as the 1 <sup>st</sup> set of serving cells by higher layers.			
Note 4: ACK/NACK bits are transmitted using PUSCH with PUCCH format 3.			
Note 5: The same PDSCH transmission mode is applied to each component carrier.			

**Table 8.2.3.3.1-2: Single carrier performance with different bandwidths for multiple CA configurations for FDD PCell and SCell (FRC)**

Band-width	Reference Channel	OCNG Pattern	Propagation Condition	Correlation Matrix and Antenna Configuration	Reference value	
					Fraction of Maximum Throughput (%)	SNR (dB)
1.4 MHz	R.14-4 FDD	OP.1 FDD	EVA5	4x2 Low	70	10.4
3 MHz	R.14-5 FDD	OP.1 FDD	EVA5	4x2 Low	70	9.5
5MHz	R.14-6 FDD	OP.1 FDD	EVA5	4x2 Low	70	9.5
10MHz	R.14 FDD	OP.1 FDD	EVA5	4x2 Low	70	10.1
15MHz	R.14-7 FDD	OP.1 FDD	EVA5	4x2 Low	70	10.1
20MHz	R.14-3 FDD	OP.1 FDD	EVA5	4x2 Low	70	10.3

**Table 8.2.3.3.1-3: Single carrier performance with different bandwidths for multiple CA configurations for TDD SCell (FRC)**

Band-width	Reference Channel	OCNG Pattern	Propagation Condition	Correlation Matrix and Antenna Configuration	Reference value	
					Fraction of Maximum Throughput (%)	SNR (dB)
1.4 MHz	R.43-1 TDD	OP.1 TDD	EVA5	4x2 Low	70	11.0
3 MHz	R.43-2 TDD	OP.1 TDD	EVA5	4x2 Low	70	9.8
5MHz	R.43-3 TDD	OP.1 TDD	EVA5	4x2 Low	70	10.0
10MHz	R.43-4 TDD	OP.1 TDD	EVA5	4x2 Low	70	10.5
15MHz	R.43-5 TDD	OP.1 TDD	EVA5	4x2 Low	70	10.6
20MHz	R.43 TDD	OP.1 TDD	EVA5	4x2 Low	70	10.7

**Table 8.2.3.3.1-4: Minimum performance for multiple CA configurations with 2DL CCs (FRC)**

Test number	Aggregated Bandwidth (MHz)			Minimum performance requirement	UE Category
	Total	FDD CC	TDD CC		
1	2x20	20	20	As defined in Table 8.2.3.3.1-2 and Table 8.2.3.3.1-3 per CC	≥5
2	20+10	10	20	As defined in Table 8.2.3.3.1-2 and Table 8.2.3.3.1-3 per CC	≥5
3	20+15	15	20	As defined in Table 8.2.3.3.1-2 and Table 8.2.3.3.1-3 per CC	≥5
Note 1:	The applicability of requirements for different CA configurations and bandwidth combination sets is defined in 8.1.2.3B				



Table 8.2.3.3.1-5: Minimum performance for multiple CA configurations with 3DL CCs (FRC)

Test number	Aggregated Bandwidth (MHz)			Minimum performance requirement	UE Category
	Total	FDD CC	TDD CC		
1	3x20	20	2x20	As defined in Table 8.2.3.3.1-2 and Table 8.2.3.3.1-3 per CC	≥5
2	20+20+15	15	2x20	As defined in Table 8.2.3.3.1-2 and Table 8.2.3.3.1-3 per CC	≥5
3	20+20+10	10	2x20	As defined in Table 8.2.3.3.1-2 and Table 8.2.3.3.1-3 per CC	≥5
4	3x20	2x20	20	As defined in Table 8.2.3.3.1-2 and Table 8.2.3.3.1-3 per CC	≥5
5	20+20+15	20+15	20	As defined in Table 8.2.3.3.1-2 and Table 8.2.3.3.1-3 per CC	≥5
6	20+20+10	20+10	20	As defined in Table 8.2.3.3.1-2 and Table 8.2.3.3.1-3 per CC	≥5
7	20+10+10	2x10	20	As defined in Table 8.2.3.3.1-2 and Table 8.2.3.3.1-3 per CC	≥5
8	10+15+20	10	15+20	As defined in Table 8.2.3.3.1-2 and Table 8.2.3.3.1-3 per CC	≥5
9	10+15+20	10+15	20	As defined in Table 8.2.3.3.1-2 and Table 8.2.3.3.1-3 per CC	≥5

Note 1: The applicability of requirements for different CA configurations and bandwidth combination sets is defined in 8.1.2.3B.

Table 8.2.3.3.1-6: Minimum performance for multiple CA configurations with 4DL CCs (FRC)

Test number	Aggregated Bandwidth (MHz)			Minimum performance requirement	UE Category
	Total	FDD CC	TDD CC		
1	4x20	20	3x20	As defined in Table 8.2.3.3.1-2 and Table 8.2.3.3.1-3 per CC	≥8
2	4x20	2x20	2x20	As defined in Table 8.2.3.3.1-2 and Table 8.2.3.3.1-3 per CC	≥8
3	3x20+15	20+15	2x20	As defined in Table 8.2.3.3.1-2 and Table 8.2.3.3.1-3 per CC	≥8
4	2x15+2x20	2x15	2x20	As defined in Table 8.2.3.3.1-2 and Table 8.2.3.3.1-3 per CC	≥8
5	3x20+15	2x20+15	20	As defined in Table 8.2.3.3.1-2 and Table 8.2.3.3.1-3 per CC	≥8
6	2x15+2x20	2x15+20	20	As defined in Table 8.2.3.3.1-2 and Table 8.2.3.3.1-3 per CC	≥8
7	3x20+10	2x20+10	20	As defined in Table 8.2.3.3.1-2 and Table 8.2.3.3.1-3 per CC	≥8
8	4x20	3x20	20	As defined in Table 8.2.3.3.1-2 and Table 8.2.3.3.1-3 per CC	≥8
9	10+3x20	10	3x20	As defined in Table 8.2.3.3.1-2 and Table 8.2.3.3.1-3 per CC	≥8
10	2x10+2x20	2x10	2x20	As defined in Table 8.2.3.3.1-2 and Table 8.2.3.3.1-3 per CC	≥8
11	2x10+20+15	2x10	20+15	As defined in Table 8.2.3.3.1-2 and Table 8.2.3.3.1-3 per CC	≥8
12	10+3x20	10+20	2x20	As defined in Table 8.2.3.3.1-2 and Table 8.2.3.3.1-3 per CC	≥8
13	10+15+2x20	10+15	2x20	As defined in Table 8.2.3.3.1-2 and Table 8.2.3.3.1-3 per CC	≥8
14	10+15+2x20	10+15+20	20	As defined in Table 8.2.3.3.1-2 and Table 8.2.3.3.1-3 per CC	≥8

Note 1: The applicability of requirements for different CA configurations and bandwidth combination sets is defined in 8.1.2.3B.

Table 8.2.3.3.1-7: Minimum performance for multiple CA configurations with 5DL CCs (FRC)

Test number	Aggregated Bandwidth (MHz)			Minimum performance requirement	UE Category
	Total	FDD CC	TDD CC		
1	15+4x20	15+2x20	2x20	As defined in Table 8.2.3.3.1-2 and Table 8.2.3.3.1-3 per CC	8, ≥11
2	2x15+3x20	2x15+20	2x20	As defined in Table 8.2.3.3.1-2 and Table 8.2.3.3.1-3 per CC	8, ≥11
3	4x20+20	4x20	20	As defined in Table 8.2.3.3.1-2 and Table 8.2.3.3.1-3 per CC	8, ≥11
4	3x20+2x20	3x20	2x20	As defined in Table 8.2.3.3.1-2 and Table 8.2.3.3.1-3 per CC	8, ≥11
5	2x20+3x20	2x20	3x20	As defined in Table 8.2.3.3.1-2 and Table 8.2.3.3.1-3 per CC	8, ≥11
6	20+4x20	20	4x20	As defined in Table 8.2.3.3.1-2 and Table 8.2.3.3.1-3 per CC	8, ≥11
7	10+4x20	10	4x20	As defined in Table 8.2.3.3.1-2 and Table 8.2.3.3.1-3 per CC	8, ≥11
8	10+20+3x20	10+20	3x20	As defined in Table 8.2.3.3.1-2 and Table 8.2.3.3.1-3 per CC	8, ≥11
9	2x10+3x20	2x10	3x20	As defined in Table 8.2.3.3.1-2 and Table 8.2.3.3.1-3 per CC	8, ≥11
10	10+2x20+2x20	10+2x20	2x20	As defined in Table 8.2.3.3.1-2 and Table 8.2.3.3.1-3 per CC	8, ≥11
11	10+15+20+2x20	10+15+20	2x20	As defined in Table 8.2.3.3.1-2 and Table 8.2.3.3.1-3 per CC	8, ≥11

Note 1: The applicability of requirements for different CA configurations and bandwidth combination sets is defined in 8.1.2.3B

Table 8.2.3.3.1-8: Minimum performance for multiple CA configurations with 6DL CCs (FRC)

Test number	CA Bandwidth combination (MHz)			Minimum performance requirement	UE Category
	Total	FDD CC	TDD CC		
1	1x20+5x20	1x20	5x20	As defined in Table 8.2.3.3.1-2 and Table 8.2.3.3.1-3 per CC	8, ≥11
2	2x20+4x20	2x20	4x20	As defined in Table 8.2.3.3.1-2 and Table 8.2.3.3.1-3 per CC	8, ≥11

Table 8.2.3.3.1-9: Minimum performance for multiple CA configurations with 7DL CCs (FRC)

Test number	CA Bandwidth combination (MHz)			Minimum performance requirement	UE Category
	Total	FDD CC	TDD CC		
1	1x20+6x20	1x20	6x20	As defined in Table 8.2.3.3.1-2 and Table 8.2.3.3.1-3 per CC	8, ≥11
2	2x20+5x20	2x20	5x20	As defined in Table 8.2.3.3.1-2 and Table 8.2.3.3.1-3 per CC	8, ≥11

### 8.2.3.3.2 Minimum Requirement for TDD PCell

For TDD FDD CA with TDD PCell and 2DL CCs, the requirements are specified in Table 8.2.3.3.2-4 based on single carrier requirement specified in Table 8.2.3.3.2-2 and Table 8.2.3.3.2-3, with the addition of the parameters in Table 8.2.3.3.2-1 and the downlink physical channel setup according to Annex C.3.2. The purpose of these tests is to verify the closed loop rank-two performance with wideband and frequency selective precoding.

For TDD FDD CA with TDD PCell and 3DL CCs, the requirements are specified in Table 8.2.3.3.2-5 based on single carrier requirement specified in Table 8.2.3.3.2-2 and Table 8.2.3.3.2-3, with the addition of the parameters in Table

8.2.3.3.2-1 and the downlink physical channel setup according to Annex C.3.2. The purpose of these tests is to verify the closed loop rank-two performance with wideband and frequency selective precoding.

For TDD FDD CA with TDD PCell and 4DL CCs, the requirements are specified in Table 8.2.3.3.2-6 based on single carrier requirement specified in Table 8.2.3.3.2-2 and Table 8.2.3.3.2-3, with the addition of the parameters in Table 8.2.3.3.2-1 and the downlink physical channel setup according to Annex C.3.2. The purpose of these tests is to verify the closed loop rank-two performance with wideband and frequency selective precoding.

For TDD FDD CA with TDD PCell and 5DL CCs, the requirements are specified in Table 8.2.3.3.2-7 based on single carrier requirement specified in Table 8.2.3.3.2-2 and Table 8.2.3.3.2-3, with the addition of the parameters in Table 8.2.3.3.2-1 and the downlink physical channel setup according to Annex C.3.2. The purpose of these tests is to verify the closed loop rank-two performance with wideband and frequency selective precoding.

For TDD FDD CA with TDD PCell and 6DL CCs, the requirements are specified in Table 8.2.3.3.2-8 based on single carrier requirement specified in Table 8.2.3.3.2-2 and Table 8.2.3.3.2-3, with the addition of the parameters in Table 8.2.3.3.2-1 and the downlink physical channel setup according to Annex C.3.2. The purpose of these tests is to verify the closed loop rank-two performance with wideband and frequency selective precoding.

For TDD FDD CA with TDD PCell and 7DL CCs, the requirements are specified in Table 8.2.3.3.2-9 based on single carrier requirement specified in Table 8.2.3.3.2-2 and Table 8.2.3.3.2-3, with the addition of the parameters in Table 8.2.3.3.2-1 and the downlink physical channel setup according to Annex C.3.2. The purpose of these tests is to verify the closed loop rank-two performance with wideband and frequency selective precoding.

The test coverage for different number of component carriers is defined in 8.1.2.4.

**Table 8.2.3.3.2-1: Test Parameters for Multi-Layer Spatial Multiplexing (FRC) for CA**

Parameter		Unit	Value
Downlink power allocation	$\rho_A$	dB	-6
	$\rho_B$	dB	-6 (Note 1)
	$\sigma$	dB	3
$N_{oc}$ at antenna port		dBm/15kHz	-98
Precoding granularity		PRB	Wideband pre-coding for 1.4MHz, 4 for 3MHz and 5MHz CCs, 6 for 10MHz CCs, 8 for 15MHz and 20MHz CCs
PMI delay (Note 2)	FDD CC	ms	8
	TDD CC	ms	10 or 11
Reporting interval	FDD CC	ms	1
	TDD CC	ms	1 or 4 (Note 3)
Reporting mode			PUSCH 1-2
CodeBookSubsetRestriction bitmap			00000000000000000000000000000000 0000111111111111111111111100000000 00000000
CSI request field (Note 3)			'10'
PDSCH transmission mode			TM4
Note 1: $P_B = 1$ .			
Note 2: If the UE reports in an available uplink reporting instance at subframe SF#n based on PMI estimation at a downlink SF not later than SF#(n-4), this reported PMI cannot be applied at the eNB downlink before SF#(n+4).			
Note 3: Multiple CC-s under test are configured as the 1 <sup>st</sup> set of serving cells by higher layers.			
Note 4: ACK/NACK bits are transmitted using PUSCH with PUCCH format 3.			
Note 5: The same PDSCH transmission mode is applied to each component carrier.			

**Table 8.2.3.3.2-2: Single carrier performance with different bandwidths for multiple CA configurations for FDD SCell (FRC)**

Band-width	Reference Channel	OCNG Pattern	Propagation Condition	Correlation Matrix and Antenna Configuration	Reference value	
					Fraction of Maximum Throughput (%)	SNR (dB)
1.4 MHz	R.14-4 FDD	OP.1 FDD	EVA5	4x2 Low	70	10.4
3 MHz	R.14-5 FDD	OP.1 FDD	EVA5	4x2 Low	70	9.5
5MHz	R.14-6 FDD	OP.1 FDD	EVA5	4x2 Low	70	9.5
10MHz	R.14 FDD	OP.1 FDD	EVA5	4x2 Low	70	10.1
15MHz	R.14-7 FDD	OP.1 FDD	EVA5	4x2 Low	70	10.1
20MHz	R.14-3 FDD	OP.1 FDD	EVA5	4x2 Low	70	10.3

**Table 8.2.3.3.2-3: Single carrier performance with different bandwidths for multiple CA configurations for TDD PCell and SCell (FRC)**

Band-width	Reference Channel	OCNG Pattern	Propagation Condition	Correlation Matrix and Antenna Configuration	Reference value	
					Fraction of Maximum Throughput (%)	SNR (dB)
1.4 MHz	R.43-1 TDD	OP.1 TDD	EVA5	4x2 Low	70	11.0
3 MHz	R.43-2 TDD	OP.1 TDD	EVA5	4x2 Low	70	9.8
5MHz	R.43-3 TDD	OP.1 TDD	EVA5	4x2 Low	70	10.0
10MHz	R.43-4 TDD	OP.1 TDD	EVA5	4x2 Low	70	10.5
15MHz	R.43-5 TDD	OP.1 TDD	EVA5	4x2 Low	70	10.6
20MHz	R.43 TDD	OP.1 TDD	EVA5	4x2 Low	70	10.7

**Table 8.2.3.3.2-4: Minimum performance for multiple CA configurations with 2DL CCs (FRC)**

Test number	Aggregated Bandwidth (MHz)			Minimum performance requirement	UE Category
	Total	FDD CC	TDD CC		
1	2x20	20	20	As defined in Table 8.2.3.3.2-2 and Table 8.2.3.3.2-3 per CC	≥5
2	20+10	10	20	As defined in Table 8.2.3.3.2-2 and Table 8.2.3.3.2-3 per CC	≥5
3	20+15	15	20	As defined in Table 8.2.3.3.2-2 and Table 8.2.3.3.2-3 per CC	≥5

Note 1: The applicability of requirements for different CA configurations and bandwidth combination sets is defined in 8.1.2.3B

Table 8.2.3.3.2-5: Minimum performance for multiple CA configurations with 3DL CCs (FRC)

Test number	Aggregated Bandwidth (MHz)			Minimum performance requirement	UE Category
	Total	FDD CC	TDD CC		
1	3x20	20	2x20	As defined in Table 8.2.3.3.2-2 and Table 8.2.3.3.2-3 per CC	≥5
2	20+20+15	15	2x20	As defined in Table 8.2.3.3.2-2 and Table 8.2.3.3.2-3 per CC	≥5
3	20+20+10	10	2x20	As defined in Table 8.2.3.3.2-2 and Table 8.2.3.3.2-3 per CC	≥5
4	3x20	2x20	20	As defined in Table 8.2.3.3.2-2 and Table 8.2.3.3.2-3 per CC	≥5
5	20+20+15	20+15	20	As defined in Table 8.2.3.3.2-2 and Table 8.2.3.3.2-3 per CC	≥5
6	20+20+10	20+10	20	As defined in Table 8.2.3.3.2-2 and Table 8.2.3.3.2-3 per CC	≥5
7	20+10+10	2x10	20	As defined in Table 8.2.3.3.2-2 and Table 8.2.3.3.2-3 per CC	≥5
8	10+15+20	10	15+20	As defined in Table 8.2.3.3.2-2 and Table 8.2.3.3.2-3 per CC	≥5
9	10+15+20	10+15	20	As defined in Table 8.2.3.3.2-2 and Table 8.2.3.3.2-3 per CC	≥5

Note 1: The applicability of requirements for different CA configurations and bandwidth combination sets is defined in 8.1.2.3B.

Table 8.2.3.3.2-6: Minimum performance for multiple CA configurations with 4DL CCs (FRC)

Test number	Aggregated Bandwidth (MHz)			Minimum performance requirement	UE Category
	Total	FDD CC	TDD CC		
1	4x20	20	3x20	As defined in Table 8.2.3.3.2-2 and Table 8.2.3.3.2-3 per CC	≥8
2	4x20	2x20	2x20	As defined in Table 8.2.3.3.2-2 and Table 8.2.3.3.2-3 per CC	≥8
3	3x20+15	20+15	2x20	As defined in Table 8.2.3.3.2-2 and Table 8.2.3.3.2-3 per CC	≥8
4	2x15+2x20	2x15	2x20	As defined in Table 8.2.3.3.2-2 and Table 8.2.3.3.2-3 per CC	≥8
5	3x20+15	2x20+15	20	As defined in Table 8.2.3.3.2-2 and Table 8.2.3.3.2-3 per CC	≥8
6	2x15+2x20	2x15+20	20	As defined in Table 8.2.3.3.2-2 and Table 8.2.3.3.2-3 per CC	≥8
7	3x20+10	2x20+10	20	As defined in Table 8.2.3.3.2-2 and Table 8.2.3.3.2-3 per CC	≥8
8	4x20	3x20	20	As defined in Table 8.2.3.3.2-2 and Table 8.2.3.3.2-3 per CC	≥8
9	10+3x20	10	3x20	As defined in Table 8.2.3.3.2-2 and Table 8.2.3.3.2-3 per CC	≥8
10	2x10+2x20	2x10	2x20	As defined in Table 8.2.3.3.2-2 and Table 8.2.3.3.2-3 per CC	≥8
11	2x10+20+15	2x10	20+15	As defined in Table 8.2.3.3.2-2 and Table 8.2.3.3.2-3 per CC	≥8
12	10+3x20	10+20	2x20	As defined in Table 8.2.3.3.2-2 and Table 8.2.3.3.2-3 per CC	≥8
13	10+15+2x20	10+15	2x20	As defined in Table 8.2.3.3.2-2 and Table 8.2.3.3.2-3 per CC	≥8
14	10+15+2x20	10+15+20	20	As defined in Table 8.2.3.3.2-2 and Table 8.2.3.3.2-3 per CC	≥8

Note 1: The applicability of requirements for different CA configurations and bandwidth combination sets is defined in 8.1.2.3B.

Table 8.2.3.3.2-7: Minimum performance for multiple CA configurations with 5DL CCs (FRC)

Test number	Aggregated Bandwidth (MHz)			Minimum performance requirement	UE Category
	Total	FDD CC	TDD CC		
1	15+4x20	15+2x20	2x20	As defined in Table 8.2.3.3.2-2 and Table 8.2.3.3.2-3 per CC	8, ≥11
2	2x15+3x20	2x15+20	2x20	As defined in Table 8.2.3.3.2-2 and Table 8.2.3.3.2-3 per CC	8, ≥11
3	4x20+20	4x20	20	As defined in Table 8.2.3.3.2-2 and Table 8.2.3.3.2-3 per CC	8, ≥11
4	3x20+2x20	3x20	2x20	As defined in Table 8.2.3.3.2-2 and Table 8.2.3.3.2-3 per CC	8, ≥11
5	2x20+3x20	2x20	3x20	As defined in Table 8.2.3.3.2-2 and Table 8.2.3.3.2-3 per CC	8, ≥11
6	20+4x20	20	4x20	As defined in Table 8.2.3.3.2-2 and Table 8.2.3.3.2-3 per CC	8, ≥11
7	10+4x20	10	4x20	As defined in Table 8.2.3.3.2-2 and Table 8.2.3.3.2-3 per CC	8, ≥11
8	10+20+3x20	10+20	3x20	As defined in Table 8.2.3.3.2-2 and Table 8.2.3.3.2-3 per CC	8, ≥11
9	2x10+3x20	2x10	3x20	As defined in Table 8.2.3.3.2-2 and Table 8.2.3.3.2-3 per CC	8, ≥11
10	10+2x20+2x20	10+2x20	2x20	As defined in Table 8.2.3.3.2-2 and Table 8.2.3.3.2-3 per CC	8, ≥11
11	10+15+20+2x20	10+15+20	2x20	As defined in Table 8.2.3.3.2-2 and Table 8.2.3.3.2-3 per CC	8, ≥11

Note 1: The applicability of requirements for different CA configurations and bandwidth combination sets is defined in 8.1.2.3B.

Table 8.2.3.3.2-8: Minimum performance for multiple CA configurations with 6DL CCs (FRC)

Test number	CA Bandwidth combination (MHz)			Minimum performance requirement	UE Category
	Total	FDD CC	TDD CC		
1	1x20+5x20	1x20	5x20	As defined in Table 8.2.3.1.1-2 and Table 8.2.3.1.1-3 per CC	8, ≥11
2	2x20+4x20	2x20	4x20	As defined in Table 8.2.3.1.1-2 and Table 8.2.3.1.1-3 per CC	8, ≥11

Table 8.2.3.3.2-9: Minimum performance for multiple CA configurations with 7DL CCs (FRC)

Test number	CA Bandwidth combination (MHz)			Minimum performance requirement	UE Category
	Total	FDD CC	TDD CC		
1	1x20+6x20	1x20	6x20	As defined in Table 8.2.3.1.1-2 and Table 8.2.3.1.1-3 per CC	8, ≥11
2	2x20+5x20	2x20	5x20	As defined in Table 8.2.3.1.1-2 and Table 8.2.3.1.1-3 per CC	8, ≥11

#### 8.2.3.4 Minimum Requirement for Closed-loop spatial multiplexing performance 4Tx Antenna Port for dual connectivity

For dual connectivity the requirements are specified in Table 8.2.3.4-4, based on single carrier requirement specified in Table 8.2.3.4-2 and Table 8.2.3.4-3, with the addition of the parameters in Table 8.2.3.4-1 and the downlink physical channel setup according to Annex C.3.2. The purpose of these tests is to verify the closed loop rank-two performance with wideband and frequency selective precoding by using dual connectivity transmission.

**Table 8.2.3.4-1: Test Parameters for Multi-Layer Spatial Multiplexing (FRC) for TDD-FDD dual connectivity**

Parameter	Unit	Values
Downlink power allocation	$\rho_A$	dB -6
	$\rho_B$	dB -6 (Note 1)
	$\sigma$	dB -3
$N_{oc}$ at antenna port	dBm/15kHz	-98
Precoding granularity	PRB	6 for 1.4MHz, 4 for 3MHz and 5MHz CCs, 6 for 10MHz CCs, and 8 for 15MHz CCs and 20MHz CCs
PMI delay (Note 2)	ms	8 for FDD CC 10 or 11 for TDD CC
Reporting interval	ms	1 for FDD CC 1 or 4 for TDD CC (Note 3)
Reporting mode		PUSCH 1-2
CodeBookSubsetRestriction bitmap		000000000000000000000000 000011111111111111111100000000 00000000
PDSCH transmission mode		4
ACK/NACK transmission		Separate ACK/NACK feedbacks with PUCCH format 1b on the MCG and SCG
CSI feedback		Separate PUSCH feedbacks on the MCG and SCG
Time offset between MCG CC and SCG CC	$\mu$ s	0 for UE under test supporting synchronous dual connectivity; 334 for UE under test supporting both asynchronous and synchronous dual connectivity (Note 5)
<p>Note 1: <math>P_B = 1</math>.</p> <p>Note 2: If the UE reports in an available uplink reporting instance at subframe SF#n based on PMI estimation at a downlink SF not later than SF#(n-4), this reported PMI cannot be applied at the eNB downlink before SF#(n+4).</p> <p>Note 3: For Uplink - downlink configuration 1 the reporting interval will alternate between 1ms and 4ms.</p> <p>Note 4: The same PDSCH transmission mode is applied to each component carrier.</p> <p>Note 5: As defined in TS36.300 [11].</p> <p>Note 6: If the UE supports both SCG bearer and Split bearer, the SCG bearer is configured.</p>		

**Table 8.2.3.4-2: FDD single carrier performance for multiple dual connectivity configurations**

Bandwidth	Reference channel	OCNG pattern	Propagation condition	Correlation matrix and antenna config.	Reference value	
					Fraction of maximum throughput (%)	SNR (dB)
1.4MHz	R.14-4 FDD	OP. 1 FDD	EVA5	4x2 Low	70	10.36
3MHz	R.14-5 FDD	OP. 1 FDD	EVA5	4x2 Low	70	9.5
5MHz	R.14-6 FDD	OP. 1 FDD	EVA5	4x2 Low	70	9.5
10 MHz	R.14 FDD	OP. 1 FDD	EVA5	4x2 Low	70	10.1
15MHz	R.14-7 FDD	OP. 1 FDD	EVA5	4x2 Low	70	10.1
20MHz	R.14-3 FDD	OP. 1 FDD	EVA5	4x2 Low	70	10.3

**Table 8.2.3.4-3: TDD single carrier performance for multiple dual connectivity configurations**

Bandwidth	Reference channel	OCNG pattern	Propagation condition	Correlation matrix and antenna config.	Reference value	
					Fraction of maximum throughput (%)	SNR (dB)
1.4MHz	R.43-1 TDD	OP.1 TDD	EVA5	4x2 Low	70	11.0
3MHz	R.43-2 TDD	OP.1 TDD	EVA5	4x2 Low	70	9.8
5MHz	R.43-3 TDD	OP.1 TDD	EVA5	4x2 Low	70	10.0
10 MHz	R.43-4 TDD	OP.1 TDD	EVA5	4x2 Low	70	10.5
15MHz	R.43-5 TDD	OP.1 TDD	EVA5	4x2 Low	70	10.6
20MHz	R.43 TDD	OP.1 TDD	EVA5	4x2 Low	70	10.7

**Table 8.2.3.4-4: Minimum performance Multi-Layer Spatial Multiplexing (FRC) for dual connectivity**

Test num.	Bandwidth combination	Requirement	UE category
1	2x20 MHz	As specified in Table 8.2.3.4-2 and Table 8.2.3.4-3 per CC	≥5
Note 1: The OCNG pattern applies for each CC.			
Note 2: The applicability of requirements for different dual connectivity configurations and bandwidth combination sets is defined in 8.1.2.3A.			

### 8.2.3.5 HST-SFN performance

#### 8.2.3.5.0 General

The purpose of this test is to verify UE performance in the HST-SFN scenario defined in B.3A when *highSpeedEnhancedDemodulationFlag* [7] is received.

#### 8.2.3.5.1 Minimum Requirement for FDD PCell

For TDD FDD CA with FDD PCell and 2DL CCs, the requirements are specified in Table 8.2.3.5.1-4 based on single carrier requirement specified in Table 8.2.3.5.1-2 and Table 8.2.3.5.1-3, with the addition of the parameters in Table 8.2.3.5.1-1 and the downlink physical channel setup according to Annex C.3.2. The purpose is to verify the performance of large delay CDD with 2 transmitter antennas.

For TDD FDD CA with FDD PCell and 3DL CCs, the requirements are specified in Table 8.2.3.5.1-5 based on single carrier requirement specified in Table 8.2.3.5.1-2 and Table 8.2.3.5.1-3, with the addition of the parameters in Table 8.2.3.5.1-1 and the downlink physical channel setup according to Annex C.3.2. The purpose is to verify the performance of large delay CDD with 2 transmitter antennas.

For TDD FDD CA with FDD PCell and 4DL CCs, the requirements are specified in Table 8.2.3.5.1-6 based on single carrier requirement specified in Table 8.2.3.5.1-2 and Table 8.2.3.5.1-3, with the addition of the parameters in Table 8.2.3.5.1-1 and the downlink physical channel setup according to Annex C.3.2. The purpose is to verify the performance of large delay CDD with 2 transmitter antennas.

For TDD FDD CA with FDD PCell and 5DL CCs, the requirements are specified in Table 8.2.3.5.1-7 based on single carrier requirement specified in Table 8.2.3.5.1-2 and Table 8.2.3.5.1-3, with the addition of the parameters in Table 8.2.3.5.1-1 and the downlink physical channel setup according to Annex C.3.2. The purpose is to verify the performance of large delay CDD with 2 transmitter antennas.

The test coverage for different number of component carriers is defined in 8.1.2.4.



Table 8.2.3.5.1-1: Test Parameters for Large Delay CDD (FRC) for CA

Parameter	Unit	Value	
Downlink power allocation	$\rho_A$	dB	-3
	$\rho_B$	dB	-3 (Note 1)
	$\sigma$	dB	0
$N_{oc}$ at antenna port	dBm/15kHz	-98	
PDSCH transmission mode		3	
NOTE 1: $P_B = 1$ .			
NOTE 2: The same PDSCH transmission mode is applied to each component carrier.			

Table 8.2.3.5.1-2: Single carrier performance for multiple CA configurations for FDD PCell and SCell (FRC)

Bandwidth	Reference channel	OCNG pattern	Propagation condition	Correlation matrix and antenna config.	Reference value	
					Fraction of maximum throughput (%)	SNR (dB)
5 MHz	R.87-2 FDD	OP. 1 FDD	HST-SFN	2x2 Low	70	[13.9]
10 MHz	R.87 FDD	OP. 1 FDD	HST-SFN	2x2 Low	70	[13.3]
15 MHz	R.87-3 FDD	OP. 1 FDD	HST-SFN	2x2 Low	70	[13.9]
20 MHz	R.87-4 FDD	OP. 1 FDD	HST-SFN	2x2 Low	70	[14.1]

Table 8.2.3.5.1-3: Single carrier performance for multiple CA configurations for TDD SCell (FRC)

Bandwidth	Reference channel	OCNG pattern	Propagation condition	Correlation matrix and antenna config.	Reference value	
					Fraction of maximum throughput (%)	SNR (dB)
5 MHz	R.87-2 TDD	OP.1 TDD	HST-SFN	2x2 Low	70	[13.1]
10 MHz	R.87 TDD	OP.1 TDD	HST-SFN	2x2 Low	70	[13.2]
15 MHz	R.87-3 TDD	OP.1 TDD	HST-SFN	2x2 Low	70	[13.4]
20 MHz	R.87-4 TDD	OP. 1 TDD	HST-SFN	2x2 Low	70	[13.6]

Table 8.2.3.5.1-4: Minimum performance for multiple CA configurations with 2DL CCs (FRC)

Test number	Aggregated Bandwidth (MHz)			Minimum performance requirement	UE Category
	Total	FDD CC	TDD CC		
1	2x20	20	20	As defined in Table 8.2.3.5.1-2 and Table 8.2.3.5.1-3 per CC	$\geq 5$
2	20+10	10	20	As defined in Table 8.2.3.5.1-2 and Table 8.2.3.5.1-3 per CC	$\geq 5$
3	20+15	15	20	As defined in Table 8.2.3.5.1-2 and Table 8.2.3.5.1-3 per CC	$\geq 5$
NOTE:	The applicability of requirements for different CA configurations and bandwidth combination sets is defined in clause 8.1.2.3B				

Table 8.2.3.5.1-5: Minimum performance for multiple CA configurations with 3DL CCs (FRC)

Test number	Aggregated Bandwidth (MHz)			Minimum performance requirement	UE Category
	Total	FDD CC	TDD CC		
1	3x20	20	2x20	As defined in Table 8.2.3.5.1-2 and Table 8.2.3.5.1-3 per CC	≥5
2	20+20+15	15	2x20	As defined in Table 8.2.3.5.1-2 and Table 8.2.3.5.1-3 per CC	≥5
3	20+20+10	10	2x20	As defined in Table 8.2.3.5.1-2 and Table 8.2.3.5.1-3 per CC	≥5
4	3x20	2x20	20	As defined in Table 8.2.3.5.1-2 and Table 8.2.3.5.1-3 per CC	≥5
5	20+20+15	20+15	20	As defined in Table 8.2.3.5.1-2 and Table 8.2.3.5.1-3 per CC	≥5
6	20+20+10	20+10	20	As defined in Table 8.2.3.5.1-2 and Table 8.2.3.5.1-3 per CC	≥5
7	20+10+10	2x10	20	As defined in Table 8.2.3.5.1-2 and Table 8.2.3.5.1-3 per CC	≥5
8	10+15+20	10	15+20	As defined in Table 8.2.3.5.1-2 and Table 8.2.3.5.1-3 per CC	≥5
9	10+15+20	10+15	20	As defined in Table 8.2.3.5.1-2 and Table 8.2.3.5.1-3 per CC	≥5

NOTE: The applicability of requirements for different CA configurations and bandwidth combination sets is defined in clause 8.1.2.3B.

Table 8.2.3.5.1-6: Minimum performance for multiple CA configurations with 4DL CCs (FRC)

Test number	Aggregated Bandwidth (MHz)			Minimum performance requirement	UE Category
	Total	FDD CC	TDD CC		
1	4x20	20	3x20	As defined in Table 8.2.3.5.1-2 and Table 8.2.3.5.1-3 per CC	≥8
2	4x20	2x20	2x20	As defined in Table 8.2.3.5.1-2 and Table 8.2.3.5.1-3 per CC	≥8
3	3x20+15	20+15	2x20	As defined in Table 8.2.3.5.1-2 and Table 8.2.3.5.1-3 per CC	≥8
4	2x15+2x20	2x15	2x20	As defined in Table 8.2.3.5.1-2 and Table 8.2.3.5.1-3 per CC	≥8
5	3x20+15	2x20+15	20	As defined in Table 8.2.3.5.1-2 and Table 8.2.3.5.1-3 per CC	≥8
6	2x15+2x20	2x15+20	20	As defined in Table 8.2.3.5.1-2 and Table 8.2.3.5.1-3 per CC	≥8
7	3x20+10	2x20+10	20	As defined in Table 8.2.3.5.1-2 and Table 8.2.3.5.1-3 per CC	≥8
8	4x20	3x20	20	As defined in Table 8.2.3.5.1-2 and Table 8.2.3.5.1-3 per CC	≥8
9	10+3x20	10	3x20	As defined in Table 8.2.3.5.1-2 and Table 8.2.3.5.1-3 per CC	≥8
10	2x10+2x20	2x10	2x20	As defined in Table 8.2.3.5.1-2 and Table 8.2.3.5.1-3 per CC	≥8
11	2x10+20+15	2x10	20+15	As defined in Table 8.2.3.5.1-2 and Table 8.2.3.5.1-3 per CC	≥8
12	10+3x20	10+20	2x20	As defined in Table 8.2.3.5.1-2 and Table 8.2.3.5.1-3 per CC	≥8
13	10+15+2x20	10+15	2x20	As defined in Table 8.2.3.5.1-2 and Table 8.2.3.5.1-3 per CC	≥8
14	10+15+2x20	10+15+20	20	As defined in Table 8.2.3.5.1-2 and Table 8.2.3.5.1-3 per CC	≥8

NOTE: The applicability of requirements for different CA configurations and bandwidth combination sets is defined in clause 8.1.2.3B.

Table 8.2.3.5.1-7: Minimum performance for multiple CA configurations with 5DL CCs (FRC)

Test number	Aggregated Bandwidth (MHz)			Minimum performance requirement	UE Category
	Total	FDD CC	TDD CC		
1	15+4x20	15+2x20	2x20	As defined in Table 8.2.3.5.1-2 and Table 8.2.3.5.1-3 per CC	8, ≥11
2	2x15+3x20	2x15+20	2x20	As defined in Table 8.2.3.5.1-2 and Table 8.2.3.5.1-3 per CC	8, ≥11
3	4x20+20	4x20	20	As defined in Table 8.2.3.5.1-2 and Table 8.2.3.5.1-3 per CC	8, ≥11
4	3x20+2x20	3x20	2x20	As defined in Table 8.2.3.5.1-2 and Table 8.2.3.5.1-3 per CC	8, ≥11
5	2x20+3x20	2x20	3x20	As defined in Table 8.2.3.5.1-2 and Table 8.2.3.5.1-3 per CC	8, ≥11
6	20+4x20	20	4x20	As defined in Table 8.2.3.5.1-2 and Table 8.2.3.5.1-3 per CC	8, ≥11
7	10+4x20	10	4x20	As defined in Table 8.2.3.5.1-2 and Table 8.2.3.5.1-3 per CC	8, ≥11
8	10+20+3x20	10+20	3x20	As defined in Table 8.2.3.5.1-2 and Table 8.2.3.5.1-3 per CC	8, ≥11
9	2x10+3x20	2x10	3x20	As defined in Table 8.2.3.5.1-2 and Table 8.2.3.5.1-3 per CC	8, ≥11
10	10+2x20+2x20	10+2x20	2x20	As defined in Table 8.2.3.5.1-2 and Table 8.2.3.5.1-3 per CC	8, ≥11
11	10+15+20+2x20	10+15+20	2x20	As defined in Table 8.2.3.5.1-2 and Table 8.2.3.5.1-3 per CC	8, ≥11

NOTE: The applicability of requirements for different CA configurations and bandwidth combination sets is defined in clause 8.1.2.3B.

### 8.2.3.5.2 Minimum Requirement for TDD PCell

For TDD FDD CA with TDD PCell and 2DL CCs, the requirements are specified in Table 8.2.3.5.2-4 based on single carrier requirement specified in Table 8.2.3.5.2-2 and Table 8.2.3.5.2-3, with the addition of the parameters in Table 8.2.3.5.2-1 and the downlink physical channel setup according to Annex C.3.2. The purpose is to verify the performance of large delay CDD with 2 transmitter antennas.

For TDD FDD CA with TDD PCell and 3DL CCs, the requirements are specified in Table 8.2.3.5.2-5 based on single carrier requirement specified in Table 8.2.3.5.2-2 and Table 8.2.3.5.2-3, with the addition of the parameters in Table 8.2.3.5.2-1 and the downlink physical channel setup according to Annex C.3.2. The purpose is to verify the performance of large delay CDD with 2 transmitter antennas.

For TDD FDD CA with TDD PCell and 4DL CCs, the requirements are specified in Table 8.2.3.5.2-6 based on single carrier requirement specified in Table 8.2.3.5.2-2 and Table 8.2.3.5.2-3, with the addition of the parameters in Table 8.2.3.5.2-1 and the downlink physical channel setup according to Annex C.3.2. The purpose is to verify the performance of large delay CDD with 2 transmitter antennas.

For TDD FDD CA with TDD PCell and 5DL CCs, the requirements are specified in Table 8.2.3.5.2-7 based on single carrier requirement specified in Table 8.2.3.5.2-2 and Table 8.2.3.5.2-3, with the addition of the parameters in Table 8.2.3.5.2-1 and the downlink physical channel setup according to Annex C.3.2. The purpose is to verify the performance of large delay CDD with 2 transmitter antennas.

The test coverage for different number of component carriers is defined in 8.1.2.4.

Table 8.2.3.5.2-1: Test Parameters for Large Delay CDD (FRC) for CA

Parameter	Unit	Value	
Downlink power allocation	$\rho_A$	dB	-3
	$\rho_B$	dB	-3 (Note 1)
	$\sigma$	dB	0
$N_{oc}$ at antenna port	dBm/15kHz	-98	
PDSCH transmission mode		3	
NOTE 1: $P_B = 1$ .			
NOTE 2: The same PDSCH transmission mode is applied to each component carrier.			

Table 8.2.3.5.2-2: Single carrier performance with different bandwidths for multiple CA configurations for FDD SCell (FRC)

Bandwidth	Reference Channel	OCNG Pattern	Propagation Condition	Correlation Matrix and Antenna Configuration	Reference value	
					Fraction of Maximum Throughput (%)	SNR (dB)
5 MHz	R.87-2 FDD	OP.1 FDD	HST-SFN	2x2 Low	70	[13.9]
10 MHz	R.87 FDD	OP.1 FDD	HST-SFN	2x2 Low	70	[13.3]
15 MHz	R.87-3 FDD	OP.1 FDD	HST-SFN	2x2 Low	70	[13.9]
20 MHz	R.87-4 FDD	OP.1 FDD	HST-SFN	2x2 Low	70	[14.1]

Table 8.2.3.5.2-3: Single carrier performance with different bandwidths for multiple CA configurations for TDD PCell and SCell (FRC)

Bandwidth	Reference Channel	OCNG Pattern	Propagation Condition	Correlation Matrix and Antenna Configuration	Reference value	
					Fraction of Maximum Throughput (%)	SNR (dB)
5 MHz	R.87-2 TDD	OP.1 TDD	HST-SFN	2x2 Low	70	[13.1]
10 MHz	R.87 TDD	OP.1 TDD	HST-SFN	2x2 Low	70	[13.2]
15 MHz	R.87-3 TDD	OP.1 TDD	HST-SFN	2x2 Low	70	[13.4]
20 MHz	R.87-4 TDD	OP.1 TDD	HST-SFN	2x2 Low	70	[13.6]

Table 8.2.3.5.2-4: Minimum performance for multiple CA configurations with 2DL CCs (FRC)

Test number	Aggregated Bandwidth (MHz)			Minimum performance requirement	UE Category
	Total	FDD CC	TDD CC		
1	2x20	20	20	As defined in Table 8.2.3.5.2-2 and Table 8.2.3.5.2-3 per CC	$\geq 5$
2	20+10	10	20	As defined in Table 8.2.3.5.2-2 and Table 8.2.3.5.2-3 per CC	$\geq 5$
3	20+15	15	20	As defined in Table 8.2.3.5.2-2 and Table 8.2.3.5.2-3 per CC	$\geq 5$
NOTE:	The applicability of requirements for different CA configurations and bandwidth combination sets is defined in clause 8.1.2.3B				

Table 8.2.3.5.2-5: Minimum performance for multiple CA configurations with 3DL CCs (FRC)

Test number	Aggregated Bandwidth (MHz)			Minimum performance requirement	UE Category
	Total	FDD CC	TDD CC		
1	3x20	20	2x20	As defined in Table 8.2.3.5.2-2 and Table 8.2.3.5.2-3 per CC	≥5
2	20+20+15	15	2x20	As defined in Table 8.2.3.5.2-2 and Table 8.2.3.5.2-3 per CC	≥5
3	20+20+10	10	2x20	As defined in Table 8.2.3.5.2-2 and Table 8.2.3.5.2-3 per CC	≥5
4	3x20	2x20	20	As defined in Table 8.2.3.5.2-2 and Table 8.2.3.5.2-3 per CC	≥5
5	20+20+15	20+15	20	As defined in Table 8.2.3.5.2-2 and Table 8.2.3.5.2-3 per CC	≥5
6	20+20+10	20+10	20	As defined in Table 8.2.3.5.2-2 and Table 8.2.3.5.2-3 per CC	≥5
7	20+10+10	2x10	20	As defined in Table 8.2.3.5.2-2 and Table 8.2.3.5.2-3 per CC	≥5
8	10+15+20	10	15+20	As defined in Table 8.2.3.5.2-2 and Table 8.2.3.5.2-3 per CC	≥5
9	10+15+20	10+15	20	As defined in Table 8.2.3.5.2-2 and Table 8.2.3.5.2-3 per CC	≥5

NOTE: The applicability of requirements for different CA configurations and bandwidth combination sets is defined in clause 8.1.2.3B.

Table 8.2.3.5.2-6: Minimum performance for multiple CA configurations with 4DL CCs (FRC)

Test number	Aggregated Bandwidth (MHz)			Minimum performance requirement	UE Category
	Total	FDD CC	TDD CC		
1	4x20	20	3x20	As defined in Table 8.2.3.5.2-2 and Table 8.2.3.5.2-3 per CC	≥8
2	4x20	2x20	2x20	As defined in Table 8.2.3.5.2-2 and Table 8.2.3.5.2-3 per CC	≥8
3	3x20+15	20+15	2x20	As defined in Table 8.2.3.5.2-2 and Table 8.2.3.5.2-3 per CC	≥8
4	2x15+2x20	2x15	2x20	As defined in Table 8.2.3.5.2-2 and Table 8.2.3.5.2-3 per CC	≥8
5	3x20+15	2x20+15	20	As defined in Table 8.2.3.5.2-2 and Table 8.2.3.5.2-3 per CC	≥8
6	2x15+2x20	2x15+20	20	As defined in Table 8.2.3.5.2-2 and Table 8.2.3.5.2-3 per CC	≥8
7	3x20+10	2x20+10	20	As defined in Table 8.2.3.5.2-2 and Table 8.2.3.5.2-3 per CC	≥8
8	4x20	3x20	20	As defined in Table 8.2.3.5.2-2 and Table 8.2.3.5.2-3 per CC	≥8
9	10+3x20	10	3x20	As defined in Table 8.2.3.5.2-2 and Table 8.2.3.5.2-3 per CC	≥8
10	2x10+2x20	2x10	2x20	As defined in Table 8.2.3.5.2-2 and Table 8.2.3.5.2-3 per CC	≥8
11	2x10+20+15	2x10	20+15	As defined in Table 8.2.3.5.2-2 and Table 8.2.3.5.2-3 per CC	≥8
12	10+3x20	10+20	2x20	As defined in Table 8.2.3.5.2-2 and Table 8.2.3.5.2-3 per CC	≥8
13	10+15+2x20	10+15	2x20	As defined in Table 8.2.3.5.2-2 and Table 8.2.3.5.2-3 per CC	≥8
14	10+15+2x20	10+15+20	20	As defined in Table 8.2.3.5.2-2 and Table 8.2.3.5.2-3 per CC	≥8

NOTE: The applicability of requirements for different CA configurations and bandwidth combination sets is defined in clause 8.1.2.3B.

Table 8.2.3.5.2-7: Minimum performance for multiple CA configurations with 5DL CCs (FRC)

Test number	Aggregated Bandwidth (MHz)			Minimum performance requirement	UE Category
	Total	FDD CC	TDD CC		
1	15+4x20	15+2x20	2x20	As defined in Table 8.2.3.5.2-2 and Table 8.2.3.5.2-3 per CC	8, ≥11
2	2x15+3x20	2x15+20	2x20	As defined in Table 8.2.3.5.2-2 and Table 8.2.3.5.2-3 per CC	8, ≥11
3	4x20+20	4x20	20	As defined in Table 8.2.3.5.2-2 and Table 8.2.3.5.2-3 per CC	8, ≥11
4	3x20+2x20	3x20	2x20	As defined in Table 8.2.3.5.2-2 and Table 8.2.3.5.2-3 per CC	8, ≥11
5	2x20+3x20	2x20	3x20	As defined in Table 8.2.3.5.2-2 and Table 8.2.3.5.2-3 per CC	8, ≥11
6	20+4x20	20	4x20	As defined in Table 8.2.3.5.2-2 and Table 8.2.3.5.2-3 per CC	8, ≥11
7	10+4x20	10	4x20	As defined in Table 8.2.3.5.2-2 and Table 8.2.3.5.2-3 per CC	8, ≥11
8	10+20+3x20	10+20	3x20	As defined in Table 8.2.3.5.2-2 and Table 8.2.3.5.2-3 per CC	8, ≥11
9	2x10+3x20	2x10	3x20	As defined in Table 8.2.3.5.2-2 and Table 8.2.3.5.2-3 per CC	8, ≥11
10	10+2x20+2x20	10+2x20	2x20	As defined in Table 8.2.3.5.2-2 and Table 8.2.3.5.2-3 per CC	8, ≥11
11	10+15+20+2x20	10+15+20	2x20	As defined in Table 8.2.3.5.2-2 and Table 8.2.3.5.2-3 per CC	8, ≥11

NOTE: The applicability of requirements for different CA configurations and bandwidth combination sets is defined in clause 8.1.2.3B.

## 8.2.4 LAA

### 8.2.4.1 Closed-loop spatial multiplexing performance 4Tx Antenna Port

#### 8.2.4.1.1 FDD PCell (FDD single carrier)

The parameters specified in Table 8.2.4.1.1-1 are valid for FDD CC and LAA SCell(s) unless otherwise stated. And the additional parameters specified in Table 8.2.4.1.1-2 are valid for LAA SCell(s).

Table 8.2.4.1.1-1: Common Test Parameters

Parameter	Unit	Value
Inter-TTI Distance		1
Number of HARQ processes per component carrier	Processes	8
Maximum number of HARQ transmission (Note 1)		4
Redundancy version coding sequence		{0,1,2,3} for QPSK and 16QAM {0,0,1,2} for 64QAM and 256QAM
Cyclic Prefix		Normal
Cell_ID		0
Cross carrier scheduling		Not configured
Note 1: For retransmission in partial subframes, the TB size should be kept the same as the initial transmission regardless of the initial transmission is performed in full subframes or partial subframes.		

Table 8.2.4.1.1-2: Additional Test Parameters for LAA SCell(s)

Parameter	Unit	Value
DMTC Periodicity	ms	80
dmtc-PeriodOffset-r12 ms80-r12		0
Discovery signal occasion duration	subframe	1
Power allocation of discovery signal		Same as power allocation of CRS within a transmission burst in the test

For CA with LAA SCell(s), the requirements are specified in Table 8.2.4.1.1-4, with the addition of the parameters in Table 8.2.4.1.1-1, Table 8.2.4.1.1-2, Table 8.2.4.1.1-3 and the downlink physical channel setup according to Annex C.3.2. The purpose of these tests is to verify the closed loop rank-two performance with frequency selective precoding for CA with LAA SCell(s).

The test coverage for different number of component carriers is defined in 8.1.2.4.

Table 8.2.4.1.1-3: Test Parameters for Dual-Layer Spatial Multiplexing (FRC)

Parameter	Unit	Value
Downlink power allocation	$\rho_A$	dB
	$\rho_B$	dB
	$\sigma$	dB
$N_{oc}$ at antenna port	dBm/15kHz	-98
Precoding granularity	PRB	4 for 3MHz and 5MHz CCs, 6 for 10MHz CCs, 8 for 15MHz and 20MHz CCs
PMI delay (Note 2)	ms	8
Reporting interval	ms	1
Reporting mode		PUSCH 1-2
CodeBookSubsetRestriction bitmap		00000000000000000000000000000000 0011111111111111111110000000000000 0000
CSI request field (Note 3)		'10'
PDSCH transmission mode		TM4
DL Burst transmission pattern for LAA SCell		As specified in B.8
The number of subframes set ( $S_i$ ) in a burst		{1,3,5,8}
Occupied OFDM symbols set in the last subframe		{6,9,12,14}
Random variable $p$ defined in B.8		0.5
timing error relative of LAA SCell to PCell	$\mu$ s	0
Frequency offset of th $i$ -th LAA SCell relative to PCell	Hz	200
Note 1: $P_B = 1$ .		
Note 2: If the UE reports in an available uplink reporting instance at subframe SF#n based on PMI estimation at a downlink SF not later than SF#(n-4), this reported PMI cannot be applied at the eNB downlink before SF#(n+4).		
Note 3: Multiple CC-s under test are configured as the 1 <sup>st</sup> set of serving cells by higher layers.		
Note 4: ACK/NACK bits are transmitted using PUSCH with PUCCH format 3.		
Note 5: The same PDSCH transmission mode is applied to each component carrier.		

Table 8.2.4.1.1-4: Single carrier performance for PCell for multiple CA configurations

Bandwidth	Reference channel	OCNG pattern	Propagation condition	Correlation matrix and antenna config.	Reference value	
					Fraction of maximum throughput (%)	SNR (dB)
1.4MHz	R.14-4 FDD	OP.1 FDD	EVA5	4x2 Low	70	10.4
3MHz	R.14-5 FDD	OP.1 FDD	EVA5	4x2 Low	70	9.5
5MHz	R.14-6 FDD	OP.1 FDD	EVA5	4x2 Low	70	9.5
10MHz	R.14 FDD	OP.1 FDD	EVA5	4x2 Low	70	10.1
15MHz	R.14-7 FDD	OP.1 FDD	EVA5	4x2 Low	70	10.1
20MHz	R.14-3 FDD	OP.1 FDD	EVA5	4x2 Low	70	10.3

Table 8.2.4.1.1-5: Single carrier performance for LAA SCell(s) for multiple CA configurations

Bandwidth	Sub-test (Note 2)	Reference channel	OCNG pattern	Propagation condition	Correlation matrix and antenna config.	Reference value	
						Fraction of nominal maximum throughput (%) (Note 1)	SNR (dB)
20MHz	1	R.1 FS3	OP.1 FS3	EVA5	4x2 Low	70	18.7
	2	R.1 FS3	OP.1 FS3	EVA5	4x2 Low	70	18.6
	3	R.1 FS3	OP.1 FS3	EVA5	4x2 Low	70	18.9
	4	R.1 FS3	OP.1 FS3	EVA5	4x2 Low	70	19

Note 1: Fraction of nominal maximum throughput is calculated based on random transmission occasions of PDSCH.

Note 2: An UE is required to fulfill only one test of Sub-test 1-4 depending on UE capabilities of endingDwPTS and secondSlotStartingPosition. For an UE not supporting both endingDwPTS and secondSlotStartingPosition, it is required to fulfill Sub-test 1; For an UE not supporting endingDwPTS but supporting secondSlotStartingPosition, it is required to fulfill Sub-test 2; For an UE supporting endingDwPTS but not supporting secondSlotStartingPosition, it is required to fulfill Sub-test 3; and For an UE supporting both endingDwPTS and secondSlotStartingPosition, it is required to fulfill Sub-test 4.

Table 8.2.4.1.1-6: Minimum performance (FRC) based on single carrier performance for CA with one LAA SCell

Test number	Aggregated Bandwidth (MHz)			Minimum performance requirement (Note 2)	UE Category
	Total	PCell	LAA SCell		
1	2x20	20	20	As defined in Table 8.2.4.1.1-4 and Table 8.2.4.1.1-5	≥5
2	15+20	15	20	As defined in Table 8.2.4.1.1-4 and Table 8.2.4.1.1-5	≥5
3	10+20	10	20	As defined in Table 8.2.4.1.1-4 and Table 8.2.4.1.1-5	≥5

Note 1: The applicability of requirements for different CA configurations and bandwidth combination sets is defined in 8.1.2.3D.

Note 2: Apply a per-CC requirement defined in 8.2.4.1.1-4 for PCell and apply a per-CC requirement defined in 8.2.4.1.1-5 for LAA SCell.



**Table 8.2.4.1.1-7: Minimum performance (FRC) based on single carrier performance for CA with two LAA SCells**

Test number	Aggregated Bandwidth (MHz)			Minimum performance requirement (Note 2)	UE Category
	Total	PCell	LAA SCell		
1	3x20	20	2x20	As defined in Table 8.2.4.1.1-4 and Table 8.2.4.1.1-5	≥5
2	15+2x20	15	2x20	As defined in Table 8.2.4.1.1-4 and Table 8.2.4.1.1-5	≥5
3	10+2x20	10	2x20	As defined in Table 8.2.4.1.1-4 and Table 8.2.4.1.1-5	≥5
Note 1:	The applicability of requirements for different CA configurations and bandwidth combination sets is defined in 8.1.2.3D.				
Note 2:	Apply a per-CC requirement defined in Table 8.2.4.1.1-4 for PCell and apply a per-CC requirement defined in Table 8.2.4.1.1-5 for LAA SCell.				

**Table 8.2.4.1.1-8: Minimum performance (FRC) based on single carrier performance for CA with three LAA SCells**

Test number	Aggregated Bandwidth (MHz)			Minimum performance requirement (Note 2)	UE Category
	Total	PCell	LAA SCell		
1	4x20	20	3x20	As defined in Table 8.2.4.1.1-4 and Table 8.2.4.1.1-5	≥5
2	15+3x20	15	3x20	As defined in Table 8.2.4.1.1-4 and Table 8.2.4.1.1-5	≥5
3	10+3x20	10	3x20	As defined in Table 8.2.4.1.1-4 and Table 8.2.4.1.1-5	≥5
Note 1:	The applicability of requirements for different CA configurations and bandwidth combination sets is defined in 8.1.2.3D.				
Note 2:	Apply a per-CC requirement defined in Table 8.2.4.1.1-4 for PCell and apply a per-CC requirement defined in Table 8.2.4.1.1-5 for LAA SCell.				

**Table 8.2.4.1.1-9: Minimum performance (FRC) based on single carrier performance for CA with four LAA SCells**

Test number	Aggregated Bandwidth (MHz)			Minimum performance requirement (Note 2)	UE Category
	Total	PCell	LAA SCell		
1	5x20	20	4x20	As defined in Table 8.2.4.1.1-4 and Table 8.2.4.1.1-5	≥5
2	15+4x20	15	4x20	As defined in Table 8.2.4.1.1-4 and Table 8.2.4.1.1-5	≥5
3	10+4x20	10	4x20	As defined in Table 8.2.4.1.1-4 and Table 8.2.4.1.1-5	≥5
Note 1:	The applicability of requirements for different CA configurations and bandwidth combination sets is defined in 8.1.2.3D.				
Note 2:	Apply a per-CC requirement defined in Table 8.2.4.1.1-4 for PCell and apply a per-CC requirement defined in Table 8.2.4.1.1-5 for LAA SCell.				

**Table 8.2.4.1.1-10: Minimum performance (FRC) based on single carrier performance for CA with five LAA SCells**

Test number	Aggregated Bandwidth (MHz)			Minimum performance requirement (Note 2)	UE Category
	Total	PCell	LAA SCell		
1	6x20	20	5x20	As defined in Table 8.2.4.1.1-4 and Table 8.2.4.1.1-5	≥5
2	15+5x20	15	5x20	As defined in Table 8.2.4.1.1-4 and Table 8.2.4.1.1-5	≥5
3	10+5x20	10	5x20	As defined in Table 8.2.4.1.1-4 and Table 8.2.4.1.1-5	≥5
Note 1:	The applicability of requirements for different CA configurations and bandwidth combination sets is defined in 8.1.2.3D.				
Note 2:	Apply a per-CC requirement defined in Table 8.2.4.1.1-4 for PCell and apply a per-CC requirement defined in Table 8.2.4.1.1-5 for LAA SCell.				

**Table 8.2.4.1.1-11: Minimum performance (FRC) based on single carrier performance for CA with six LAA SCells**

Test number	Aggregated Bandwidth (MHz)			Minimum performance requirement (Note 2)	UE Category
	Total	PCell	LAA SCell		
1	7x20	20	6x20	As defined in Table 8.2.4.1.1-4 and Table 8.2.4.1.1-5	≥5
2	15+6x20	15	6x20	As defined in Table 8.2.4.1.1-4 and Table 8.2.4.1.1-5	≥5
3	10+6x20	10	6x20	As defined in Table 8.2.4.1.1-4 and Table 8.2.4.1.1-5	≥5
Note 1:	The applicability of requirements for different CA configurations and bandwidth combination sets is defined in 8.1.2.3D.				
Note 2:	Apply a per-CC requirement defined in Table 8.2.4.1.1-4 for PCell and apply a per-CC requirement defined in Table 8.2.4.1.1-5 for LAA SCell.				

**8.2.4.1.2 TDD PCell (TDD single carrier)**

The parameters specified in Table 8.2.4.1.2-1 are valid for TDD CC and LAA SCell(s) unless otherwise stated. And the additional parameters specified in Table 8.2.4.1.2-2 are valid for LAA SCell(s).

**Table 8.2.4.1.2-1: Common Test Parameters (TDD)**

Parameter	Unit	Value
Uplink downlink configuration (Note 1)		1
Special subframe configuration (Note 2)		4
Cyclic prefix		Normal
Cell ID		0
Inter-TTI Distance		1
Number of HARQ processes per component carrier	Processes	7
Maximum number of HARQ transmission (Note 3)		4
Redundancy version coding sequence		{0,1,2,3} for QPSK and 16QAM {0,0,1,2} for 64QAM and 256QAM
Cross carrier scheduling		Not configured
Note 1:	as specified in Table 4.2-2 in TS 36.211 [4].	
Note 2:	as specified in Table 4.2-1 in TS 36.211 [4].	
Note 3:	For retransmission in partial subframes, the TB size should be kept the same as the initial transmission regardless of the initial transmission is performed in full subframes or partial subframes.	

**Table 8.2.4.1.2-2: Additional Test Parameters for LAA SCell(s)**

Parameter	Unit	Value
DMTC Periodicity	ms	80
dmtc-PeriodOffset-r12 ms80-r12		0
Discovery signal occasion duration	subframe	1
Power allocation of discovery signal		Same as power allocation of CRS within a transmission burst in the test

For CA with LAA SCell(s), the requirements are specified in Table 8.2.4.1.2-4, with the addition of the parameters in Table 8.2.4.1.2-1, Table 8.2.4.1.2-2, Table 8.2.4.1.2-3 and the downlink physical channel setup according to Annex C.3.2. The purpose of these tests is to verify the closed loop rank-two performance with frequency selective precoding for CA with LAA SCell(s).

The test coverage for different number of component carriers is defined in 8.1.2.4.

**Table 8.2.4.1.2-3: Test Parameters for Dual-Layer Spatial Multiplexing (FRC)**

Parameter	Unit	Value
Downlink power allocation	$\rho_A$	-6
	$\rho_B$	-6 (Note 1)
	$\sigma$	3
$N_{oc}$ at antenna port	dBm/15kHz	-98
Precoding granularity	PRB	4 for 3MHz and 5MHz CCs, 6 for 10MHz CCs, 8 for 15MHz and 20MHz CCs
PMI delay (Note 2)	ms	10 or 11
Reporting interval	ms	1 or 4 (Note 3)
Reporting mode		PUSCH 1-2
CodeBookSubsetRestriction bitmap		00000000000000000000000000000000 0011111111111111111110000000000000 0000
CSI request field (Note 4)		'10'
PDSCH transmission mode		TM4
DL Burst transmission pattern for LAA SCell		As specified in B.8
The number of subframes set ( $S_i$ ) in a burst		{1,3,5,8}
Occupied OFDM symbols set in the last subframe		{6,9,12,14}
Random variable $p$ defined in B.8		0.5
timing error relative of LAA SCell to PCell	$\mu$ s	0
Frequency offset of th $i$ -th LAA SCell relative to PCell	Hz	200
Note 1: $P_B = 1$ . Note 2: If the UE reports in an available uplink reporting instance at subframe SF#n based on PMI estimation at a downlink SF not later than SF#(n-4), this reported PMI cannot be applied at the eNB downlink before SF#(n+4). Note 3: For Uplink - downlink configuration 1 the reporting interval will alternate between 1ms and 4ms. Note 4: Multiple CC-s under test are configured as the 1 <sup>st</sup> set of serving cells by higher layers. Note 5: ACK/NACK bits are transmitted using PUSCH with PUCCH format 3. Note 6: The same PDSCH transmission mode is applied to each component carrier.		

**Table 8.2.4.1.2-4: Single carrier performance for PCell for multiple CA configurations**

Bandwidth	Reference channel	OCNG pattern	Propagation condition	Correlation matrix and antenna config.	Reference value	
					Fraction of maximum throughput (%)	SNR (dB)
1.4MHz	R.43-1 TDD	OP.1 TDD	EVA5	4x2 Low	70	11.0
3MHz	R.43-2 TDD	OP.1 TDD	EVA5	4x2 Low	70	9.8
5MHz	R.43-3 TDD	OP.1 TDD	EVA5	4x2 Low	70	10.0
10MHz	R.43-4 TDD	OP.1 TDD	EVA5	4x2 Low	70	10.5
15MHz	R.43-5 TDD	OP.1 TDD	EVA5	4x2 Low	70	10.6
20MHz	R.43 TDD	OP.1 TDD	EVA5	4x2 Low	70	10.7

Table 8.2.4.1.2-5: Single carrier performance for LAA SCell for multiple CA configurations

Bandwidth	Sub-test (Note 2)	Reference channel	OCNG pattern	Propagation condition	Correlation matrix and antenna config.	Reference value	
						Fraction of maximum throughput (%) (Note 1)	SNR (dB)
20MHz	1	R.1 FS3	OP.1 FS3	EVA5	4x2 Low	70	18.7
	2	R.1 FS3	OP.1 FS3	EVA5	4x2 Low	70	18.6
	3	R.1 FS3	OP.1 FS3	EVA5	4x2 Low	70	18.9
	4	R.1 FS3	OP.1 FS3	EVA5	4x2 Low	70	19
Note 1: Fraction of nominal maximum throughput is calculated based on random transmission occasions of PDSCH.							
Note 2: An UE is required to fulfill only one test of Sub-test 1-4 depending on UE capabilities of endingDwPTS and secondSlotStartingPosition. For an UE not supporting both endingDwPTS and secondSlotStartingPosition, it is required to fulfill Sub-test 1; For an UE not supporting endingDwPTS but supporting secondSlotStartingPosition, it is required to fulfill Sub-test 2; For an UE supporting endingDwPTS but not supporting secondSlotStartingPosition, it is required to fulfill Sub-test 3; and For an UE supporting both endingDwPTS and secondSlotStartingPosition, it is required to fulfill Sub-test 4.							

Table 8.2.4.1.2-6: Minimum performance (FRC) based on single carrier performance for CA with one LAA SCell

Test number	Aggregated Bandwidth (MHz)			Minimum performance requirement (Note 2)	UE Category
	Total	PCell	LAA SCell		
1	2x20	20	20	As defined in Table 8.2.4.1.2-4 and Table 8.2.4.1.2-5	≥5
Note 1: The applicability of requirements for different CA configurations and bandwidth combination sets is defined in 8.1.2.3D.					
Note 2: Apply a per-CC requirement defined in 8.2.4.1.2-4 for PCell and apply a per-CC requirement defined in 8.2.4.1.2-5 for LAA SCell.					

Table 8.2.4.1.2-7: Minimum performance (FRC) based on single carrier performance for CA with two LAA SCells

Test number	Aggregated Bandwidth (MHz)			Minimum performance requirement (Note 2)	UE Category
	Total	PCell	LAA SCell		
1	3x20	20	2x20	As defined in Table 8.2.4.1.2-4 and Table 8.2.4.1.2-5	≥5
Note 1: The applicability of requirements for different CA configurations and bandwidth combination sets is defined in 8.1.2.3D.					
Note 2: Apply a per-CC requirement defined in 8.2.4.1.2-4 for PCell and apply a per-CC requirement defined in 8.2.4.1.2-5 for LAA SCell.					

Table 8.2.4.1.2-8: Minimum performance (FRC) based on single carrier performance for CA with three LAA SCells

Test number	Aggregated Bandwidth (MHz)			Minimum performance requirement (Note 2)	UE Category
	Total	PCell	LAA SCell		
1	4x20	20	3x20	As defined in Table 8.2.4.1.2-4 and Table 8.2.4.1.2-5	≥5
Note 1: The applicability of requirements for different CA configurations and bandwidth combination sets is defined in 8.1.2.3D.					
Note 2: Apply a per-CC requirement defined in 8.2.4.1.2-4 for PCell and apply a per-CC requirement defined in 8.2.4.1.2-5 for LAA SCell.					

**Table 8.2.4.1.2-9: Minimum performance (FRC) based on single carrier performance for CA with four LAA SCells**

Test number	Aggregated Bandwidth (MHz)			Minimum performance requirement (Note 2)	UE Category
	Total	PCell	LAA SCell		
1	5x20	20	4x20	As defined in Table 8.2.4.1.2-4 and Table 8.2.4.1.2-5	≥5
Note 1:	The applicability of requirements for different CA configurations and bandwidth combination sets is defined in 8.1.2.3D.				
Note 2:	Apply a per-CC requirement defined in 8.2.4.1.2-4 for PCell and apply a per-CC requirement defined in 8.2.4.1.2-5 for LAA SCell.				

**Table 8.2.4.1.2-10: Minimum performance (FRC) based on single carrier performance for CA with five LAA SCells**

Test number	Aggregated Bandwidth (MHz)			Minimum performance requirement (Note 2)	UE Category
	Total	PCell	LAA SCell		
1	6x20	20	5x20	As defined in Table 8.2.4.1.2-4 and Table 8.2.4.1.2-5	≥5
Note 1:	The applicability of requirements for different CA configurations and bandwidth combination sets is defined in 8.1.2.3D.				
Note 2:	Apply a per-CC requirement defined in 8.2.4.1.2-4 for PCell and apply a per-CC requirement defined in 8.2.4.1.2-5 for LAA SCell.				

**Table 8.2.4.1.2-11: Minimum performance (FRC) based on single carrier performance for CA with six LAA SCells**

Test number	Aggregated Bandwidth (MHz)			Minimum performance requirement (Note 2)	UE Category
	Total	PCell	LAA SCell		
1	7x20	20	6x20	As defined in Table 8.2.4.1.2-4 and Table 8.2.4.1.2-5	≥5
Note 1:	The applicability of requirements for different CA configurations and bandwidth combination sets is defined in 8.1.2.3D.				
Note 2:	Apply a per-CC requirement defined in 8.2.4.1.2-4 for PCell and apply a per-CC requirement defined in 8.2.4.1.2-5 for LAA SCell.				

## 8.3 Demodulation of PDSCH (User-Specific Reference Symbols)

### 8.3.1 FDD

The parameters specified in Table 8.3.1-1 are valid for FDD unless otherwise stated.

**Table 8.3.1-1: Common Test Parameters for User-specific Reference Symbols**

Parameter	Unit	Value
Cyclic prefix		Normal
Cell ID		0
Inter-TTI Distance		1
Number of HARQ processes	Processes	8
Maximum number of HARQ transmission		4
Redundancy version coding sequence		{0,1,2,3} for QPSK and 16QAM {0,0,1,2} for 64QAM, 256QAM and 1024QAM
Number of OFDM symbols for PDCCH	OFDM symbols	2
Precoder update granularity		Frequency domain: 1 PRG for Transmission modes 9 and 10 Time domain: 1 ms
Note 1:	Void.	
Note 2:	Void.	

### 8.3.1.1 Single-layer Spatial Multiplexing

For single-layer transmission on antenna ports 7 or 8 upon detection of a PDCCH with DCI format 2C, the requirements are specified in Table 8.3.1.1-1 and 8.3.1.1-2, with the addition of the parameters in Table 8.3.1.1-3 and the downlink physical channel setup according to Annex C.3.2. The purpose of these tests is to verify rank-1 performance on one of the antenna ports 7 or 8 with and without a simultaneous transmission on the other antenna port, and to verify rate matching with multiple CSI reference symbol configurations with non-zero and zero transmission power.

**Table 8.3.1.1-1: Test Parameters for Testing CDM-multiplexed DM RS (single layer) with multiple CSI-RS configurations**

parameter	Unit	Test 1, Test 1a	Test 2	Test 3	Test 4, Test 4a	Test 5
Downlink power allocation	$\rho_A$	dB	0	0	0	0
	$\rho_B$	dB	0 (Note 1)	0 (Note 1)	0 (Note 1)	0 (Note 1)
	$\sigma$	dB	-3	-3	-3	-3
Beamforming model		Annex B.4.1	Annex B.4.1	Annex B.4.1	Annex B.4.1	Annex B.4.1
Cell-specific reference signals		Antenna ports 0,1				
CSI reference signals		Antenna ports 15,...,18	Antenna ports 15,...,18	Antenna ports 15, ..., 18	Antenna ports 15,...,18	Antenna ports 15, ..., 18
CSI-RS periodicity and subframe offset $T_{\text{CSI-RS}} / \Delta_{\text{CSI-RS}}$	Subframes	5 / 2	5 / 2	5 / 2	5 / 2	5 / 2
CSI reference signal configuration		0	3	0	0	0
csi-RS-ConfigZP-APList		N/A	N/A	N/A	{0,1}	N/A
Zero-power CSI-RS configuration $k_{\text{CSI-RS}} / \text{ZeroPowerCSI-RS}$ bitmap	Subframes / bitmap	3 / 0001000000000000	3 / 0001000000000000	3 / 0001000000000000	0100000000000000 or 0001000000000000 (Note 7)	N/A
$N_{\text{oc}}$ at antenna port	dBm/15kHz	-98	-98	-98	-98	-98
Symbols for unused PRBs		OCNG (Note 4)	OCNG (Note 4)	OCNG (Note 4)	OCNG (Note 4)	OCNG (Note 4)
Number of allocated resource blocks (Note 2)	PRB	50	50	50	50	50
Simultaneous transmission		No	Yes (Note 3, 5)	No	No	No
PDSCH transmission mode		9	9	9	9	9
Number of MBSFN subframes	Subframes	6 (Note 6)	NA	NA	6 (Note 6)	NA
<p>Note 1: <math>P_B = 1</math>.</p> <p>Note 2: The modulation symbols of the signal under test are mapped onto antenna port 7 or 8.</p> <p>Note 3: Modulation symbols of an interference signal is mapped onto the antenna port (7 or 8) not used for the input signal under test.</p> <p>Note 4: These physical resource blocks are assigned to an arbitrary number of virtual UEs with one PDSCH per virtual UE; the data transmitted over the OCNG PDSCHs shall be uncorrelated pseudo random data, which is QPSK modulated.</p> <p>Note 5: The two UEs' scrambling identities <math>N_{\text{SCID}}</math> are set to 0 for CDM-multiplexed DM RS with interfering simultaneous transmission test cases.</p> <p>Note 6: For FDD mode, 6 subframes (#1/2/3/6/7/8) are allocated as MBSFN subframes.</p> <p>Note 7: Through DCI signalling, indicating aperiodic ZP-CSI-RS in sub-frames #3 and #8 per frame, the indicated aperiodic ZP-CSI-RS is random selected from RRC-configured AP ZP CSIRS list.</p>						

**Table 8.3.1.1-2: Minimum performance for CDM-multiplexed DM RS without simultaneous transmission (FRC) with multiple CSI-RS configurations**

Test number	Bandwidth and MCS	Reference Channel	OCNG Pattern	Propagation Condition	Correlation Matrix and Antenna Configuration	Reference value		UE Category	UE DL Category
						Fraction of Maximum Throughput (%)	SNR (dB)		
1	10 MHz QPSK 1/3	R.43-1 FDD	OP.1 FDD	EVA5	2x2 Low	70	-1.2	≥1	≥6
1a	10 MHz QPSK 1/3	R.43-2 FDD	OP.1 FDD	EVA5	2x2 Low	70	[-1.3]	≥1	≥6
3	10MHz 256QAM	R. 66 FDD	OP.1 FDD	EPA5	2x2 Low	70	24.3	11-12	≥11
4	10 MHz QPSK 1/3	R.43-1 FDD	OP.1 FDD	EVA5	2x2 Low	70	[-1.2]	≥1	≥6
4a	10 MHz QPSK 1/3	R.43-2 FDD	OP.1 FDD	EVA5	2x2 Low	[70]	TBD	≥1	≥6
5	10MHz 1024QAM	R.101 FDD	OP.1 FDD	EPA5	4x2 Low	70	30.1	TBD	20, ≥ 22

Note 1: For UE that does not support aperiodic ZP-CSI-RS, test 1a will be run and test 1 will be skipped if the UE indicates support of *pdsch-CollisionHandling-r13*. Otherwise, test 1 will be run and test 1a will be skipped. For UE that does not support aperiodic ZP-CSI-RS, test 4 and test 4a will be skipped.

Note 2: For UE that supports AP ZP CSIRS, test 4a will be run and test 4 will be skipped if the UE indicates support of *pdsch-CollisionHandling-r13*. Otherwise, test 4 will be run and test 4a will be skipped. For UE that supports AP ZP CSIRS, test 1 and test 1a will be skipped.

**Table 8.3.1.1-3: Minimum performance for CDM-multiplexed DM RS with interfering simultaneous transmission (FRC) with multiple CSI-RS configurations**

Test number	Bandwidth and MCS	Reference Channel	OCNG Pattern	Propagation Condition	Correlation Matrix and Antenna Configuration	Reference value		UE Category
						Fraction of Maximum Throughput (%)	SNR (dB)	
2	10 MHz 64QAM 1/2	R.50 FDD	OP.1 FDD	EPA5	2x2 Low	70	21.9	≥2

Note 1: The reference channel applies to both the input signal under test and the interfering signal.

### 8.3.1.1A Enhanced Performance Requirement Type A – Single-layer Spatial Multiplexing with TM9 interference model

The requirements are specified in Table 8.3.1.1A-2, with the addition of the parameters in Table 8.3.1.1A-1 and the downlink physical channel setup according to Annex C.3.2. The purpose of these tests is to verify closed loop rank one performance on one of the antenna ports 7 or 8 without a simultaneous transmission on the other antenna port in the serving cell when the PDSCH transmission in the serving cell is interfered by PDSCH of one dominant interfering cell applying transmission mode 9 interference model defined in clause B.5.4. In 8.3.1.1A-1, Cell 1 is the serving cell, and Cell 2 is the interfering cell. The downlink physical channel setup is according to Annex C.3.2 for each of Cell 1 and Cell 2, respectively.



**Table 8.3.1.1A-1: Test Parameters for Testing CDM-multiplexed DM RS (single layer) with TM9 interference model**

parameter		Unit	Cell 1	Cell 2
Downlink power allocation	$\rho_A$	dB	0	0
	$\rho_B$	dB	0 (Note 1)	0
	$\sigma$	dB	-3	-3
Cell-specific reference signals			Antenna ports 0,1	Antenna ports 0,1
CSI reference signals			Antenna ports 15,...,18	N/A
CSI-RS periodicity and subframe offset $T_{\text{CSI-RS}} / \Delta_{\text{CSI-RS}}$		Subframes	5 / 2	N/A
CSI reference signal configuration			0	N/A
$N_{oc}$ at antenna port		dBm/15kHz	-98	N/A
DIP (Note 2)		dB	N/A	-1.73
$BW_{\text{Channel}}$		MHz	10	10
Cyclic Prefix			Normal	Normal
Cell Id			0	126
Number of control OFDM symbols			2	2
PDSCH transmission mode			9	N/A
Beamforming model			As specified in clause B.4.3 (Note 4, 5)	N/A
Interference model			N/A	As specified in clause B.5.4
Probability of occurrence of transmission rank in interfering cells	Rank 1		N/A	70
	Rank 2		N/A	30
Precoder update granularity		PRB	50	6
PMI delay (Note 5)		Ms	8	N/A
Reporting interval		Ms	5	N/A
Reporting mode			PUCCH 1-1	N/A
CodeBookSubsetRestriction bitmap			0000000000000000 0000000000000000 0000000000000000 1111111111111111	N/A
Symbols for unused PRBs			OCNG (Note 6)	N/A
Simultaneous transmission			No simultaneous transmission on the other antenna port in (7 or 8) not used for the input signal under test	N/A
Physical channel for CQI reporting			PUSCH(Note 8)	N/A
cqi-pmi-ConfigurationIndex			5	N/A

Note 1:	$P_B = 1$
Note 2:	The respective received power spectral density of each interfering cell relative to $N_{oc}$ is defined by its associated DIP value as specified in clause B.5.1.
Note 3:	The modulation symbols of the signal under test in Cell 1 are mapped onto antenna port 7 or 8.
Note 4:	The precoder in clause B.4.3 follows UE recommended PMI.
Note 5:	If the UE reports in an available uplink reporting instance at subframe SF#n based on PMI estimation at a downlink SF not later than SF#(n-4), this reported PMI cannot be applied at the eNB downlink before SF#(n+4).
Note 6:	These physical resource blocks are assigned to an arbitrary number of virtual UEs with one PDSCH per virtual UE; the data transmitted over the OCNG PDSCHs shall be uncorrelated pseudo random data, which is QPSK modulated.
Note 7:	All cells are time-synchronous.
Note 8:	To avoid collisions between CQI reports and HARQ-ACK it is necessary to report both on PUSCH instead of PUCCH. PDCCH DCI format 0 shall be transmitted in downlink SF#4 and #9 to allow periodic CQI to multiplex with the HARQ-ACK on PUSCH in uplink subframe SF#8 and #3.

**Table 8.3.1.1A-2: Enhanced Performance Requirement Type A, CDM-multiplexed DM RS with TM9 interference model**

Test Number	Reference Channel	OCNG Pattern		Propagation Conditions		Correlation Matrix and Antenna Configuration (Note 3)	Reference Value		UE Category
		Cell 1	Cell 2	Cell 1	Cell 2		Fraction of Maximum Throughput (%)	SINR (dB) (Note 2)	
1	R.48 FDD	OP.1 FDD	N/A	EVA5	EVA5	4x2 Low	70	-1.1	≥1
Note 1: The propagation conditions for Cell 1 and Cell 2 are statistically independent.									
Note 2: SINR corresponds to $E_s/N_{oc}$ of Cell 1 as defined in clause 8.1.1.									
Note 3: Correlation matrix and antenna configuration parameters apply for each of Cell 1 and Cell 2.									

### 8.3.1.1B Single-layer Spatial Multiplexing (demodulation subframe overlaps with aggressor cell ABS and CRS assistance information are configured)

The requirements are specified in Table 8.3.1.1B-2, with the addition of parameters in Table 8.3.1.1B-1. The purpose is to verify the performance of the antenna ports 7 or 8 without a simultaneous transmission on the other antenna port in the serving cell if the PDSCH transmission in the serving cell takes place in subframes that overlap with ABS [9] of the aggressor cell with CRS assistance information. In Table 8.3.1.1B-1, Cell 1 is the serving cell, and Cell 2 and Cell 3 are the aggressor cells. The downlink physical channel setup for Cell 1 is according to Annex C.3.2 and for Cell 2 and Cell 3 is according to Annex C.3.3, respectively. The CRS assistance information [7] includes Cell 2 and Cell 3.

**Table 8.3.1.1B-1: Test parameters of TM9-Single-Layer (2 CSI-RS ports) – Non-MBSFN ABS**

Parameter	Unit	Cell 1	Cell 2	Cell 3	
Downlink power allocation	$\rho_A$	dB	0	-3	-3
	$\rho_B$	dB	0 (Note 1)	-3 (Note 1)	-3 (Note 1)
	$\sigma$	dB	-3	N/A	N/A
$N_{oc}$ at antenna port	$N_{oc1}$	dBm/15kHz	-98 (Note 2)	N/A	N/A
	$N_{oc2}$	dBm/15kHz	-98 (Note 3)	N/A	N/A
	$N_{oc3}$	dBm/15kHz	-93 (Note 4)	N/A	N/A
$\hat{E}_s / N_{oc2}$	dB	Reference Value in Table 8.3.1.1B-2	12	10	
$BW_{channel}$	MHz	10	10	10	
Subframe Configuration		Non-MBSFN	Non-MBSFN	Non-MBSFN	
Time Offset between Cells	$\mu$ s	N/A	3	-1	
Frequency shift between Cells	Hz	N/A	300	-100	
Cell Id		0	1	126	
Cell-specific reference signals		Antenna ports 0,1			
CSI reference signals		Antenna ports 15,16	N/A	N/A	
CSI-RS periodicity and subframe offset $T_{CSI-RS} / \Delta_{CSI-RS}$	Subframes	5 / 2	N/A	N/A	
CSI reference signal configuration		8	N/A	N/A	
Zero-power CSI-RS configuration $I_{CSI-RS} / \text{ZeroPowerCSI-RS bitmap}$	Subframes / bitmap	3 / 0010000000000000	N/A	N/A	
ABS pattern (Note 5)		N/A	11000000 11000000 11000000 11000000 11000000	11000000 11000000 11000000 11000000 11000000	
RLM/RRM Measurement Subframe Pattern (Note 6)		10000000 10000000 10000000 10000000 10000000	N/A	N/A	
CSI Subframe Sets (Note7)	$C_{CSI,0}$	11000000 11000000 11000000 11000000 11000000	N/A	N/A	
	$C_{CSI,1}$	00111111 00111111 00111111 00111111 00111111	N/A	N/A	
Number of control OFDM symbols		2	Note 8	Note 8	
PDSCH transmission mode		TM9-1layer	Note 9	Note 9	
Precoding granularity		Frequency domain: 1 PRG Time domain: 1 ms	N/A	N/A	
Beamforming model Cyclic prefix		Annex B.4.1 Normal	N/A Normal	N/A Normal	

- Note 1:  $P_p = 1$ .
- Note 2: This noise is applied in OFDM symbols #1, #2, #3, #5, #6, #8, #9, #10, #12, #13 of a subframe overlapping with the aggressor ABS.
- Note 3: This noise is applied in OFDM symbols #0, #4, #7, #11 of a subframe overlapping with the aggressor ABS.
- Note 4: This noise is applied in all OFDM symbols of a subframe overlapping with aggressor non-ABS.
- Note 5: ABS pattern as defined in [9]. PDSCH other than SIB1/paging and its associated PDCCH/PCFICH are transmitted in the serving cell subframe when the subframe is overlapped with the ABS subframe of aggressor cell and the subframe is available in the definition of the reference channel.
- Note 6: Time-domain measurement resource restriction pattern for PCell measurements as defined in [7].
- Note 7: As configured according to the time-domain measurement resource restriction pattern for CSI measurements defined in [7].
- Note 8: The number of control OFDM symbols is not available for ABS and is 2 for the subframe indicated by "0" of ABS pattern.
- Note 9: Downlink physical channel setup in Cell 2 and Cell 3 in accordance with Annex C.3.3 applying OCNG pattern as defined in Annex A.5.
- Note 10: If the UE reports in an available uplink reporting instance at subframe SF#n based on PMI estimation at a downlink SF not later than SF#(n-4), this reported PMI cannot be applied at the eNB downlink before SF#(n+4).
- Note 11: The number of the CRS ports in Cell 1, Cell 2 and Cell 3 is the same.
- Note 12: SIB-1 will not be transmitted in Cell 2 and Cell 3 in this test.
- Note 13: The modulation symbols of the signal under test are mapped onto antenna port 7 or 8.

**Table 8.3.1.1B-2: Minimum Performance of TM9-Single-Layer (2 CSI-RS ports) – Non-MBSFN ABS**

Test Number	Reference Channel	OCNG Pattern			Propagation Conditions (Note1)			Correlation Matrix and Antenna Configuration (Note 2)	Reference Value		UE Category
		Cell 1	Cell 2	Cell 3	Cell 1	Cell 2	Cell 3		Fraction of Maximum Throughput (%)	SNR (dB) (Note 3)	
1	R.51 FDD	OP.1 FDD	OP.1 FDD	OP.1 FDD	EVA5			2x2 Low	70	7.8	≥2
<p>Note 1: The propagation conditions for Cell 1, Cell 2 and Cell 3 are statistically independent.</p> <p>Note 2: The correlation matrix and antenna configuration apply for Cell 1, Cell 2 and Cell 3.</p> <p>Note 3: SNR corresponds to <math>\bar{E}_s/N_{oc,2}</math> of cell 1.</p>											

### 8.3.1.1C Enhanced Performance Requirement Type B – Single-layer Spatial Multiplexing with TM9 interference model

The requirements are specified in Table 8.3.1.1C-2, with the addition of the parameters in Table 8.3.1.1C-1 and the downlink physical channel setup according to Annex C.3.2. The purpose of these tests is to verify closed loop rank one performance on one of the antenna ports 7, 8 without a simultaneous transmission on the other antenna port in the serving cell when the PDSCH transmission in the serving cell is interfered by PDSCH of two interfering cells applying transmission mode 9 interference model defined in clause B.6.4. In 8.3.1.1C-1, Cell 1 is the serving cell, and Cell 2, 3 are interfering cells. The downlink physical channel setup is according to Annex C.3.2 for each of Cell 1, Cell 2 and Cell 3, respectively.

**Table 8.3.1.1C-1: Test Parameters for Testing CDM-multiplexed DM RS (Single-layer) with TM9 interference model**

Parameter		Unit	Cell 1	Cell 2	Cell 3
Downlink power allocation	$\rho_A$	dB	0	0	0
	$\rho_B$	dB	0 (Note 1)	0	0
	$\sigma$	dB	-3	-3	-3
Cell-specific reference signals			Antenna ports 0,1	Antenna ports 0,1	Antenna ports 0,1
$N_{oc}$ at antenna port		dBm/15kHz	-98		
$\bar{E}_s/N_{oc}$		dB	N/A	13.91	3.34
BW <sub>channel</sub>		MHz	10	10	10
Cyclic Prefix			Normal	Normal	Normal
Cell Id			0	1	6
Number of control OFDM symbols			3	3	3
CFI indicated in PCFICH			3	3	3
PDSCH transmission mode			9	9	9
Interference model			N/A	As specified in clause B.6.4	As specified in clause B.6.4
Precoding			Random wideband precoding per TTI	As specified in clause B.6.4	As specified in clause B.6.4
CSI reference signals			Antenna ports 15, 16, 17, 18	Antenna ports 15, 16	Antenna ports 15, 16
CSI-RS periodicity and subframe offset $T_{CSI-RS} / \Delta_{CSI-RS}$		Subframes	10 / 1	10 / 1	10 / 1
CSI reference signal configuration			5	6	7
Zero-power CSI-RS configuration $l_{CSI-RS} / \text{ZeroPowerCSI-RS}$ bitmap		Subframes / bitmap	6 / 10000000000 00000	6 / 01000000000 0000	6 / 00100000000 00000
Time offset to cell 1		us	N/A	2	3
Frequency offset to cell 1		Hz	N/A	200	300
MBSFN			Not configured	Not configured	Not configured
NeighCellsInfo-r12 (Note 4)	p-aList-r12		N/A	{dB-6, dB-3, dB0}	{dB-6, dB-3, dB0}
	transmissionModelList-r12		N/A	{2,3,4,8,9}	{2,3,4,8,9}
Note 1: $P_B = 1$					
Note 2: Cell 1 is the serving cell. Cell 2, 3 are the interfering cells.					
Note 3: CSI-RS configurations are according to [4] subclause 6.10.5.2.					
Note 4: NeighCellsInfo-r12 is described in subclause 6.3.2 of [7].					

**Table 8.3.1.1C-2: Minimum Performance for Enhanced Performance Requirement Type B, CDM-multiplexed DM RS with TM9 interference model**

Test Number	Reference Channel	OCNG Pattern			Propagation Conditions			Correlation Matrix and Antenna Configuration			Reference Value		UE Category
		Cell 1	Cell 2	Cell 3	Cell 1	Cell 2	Cell 3	Cell 1	Cell 2	Cell 3	Fraction of Maximum Throughput (%)	SNR (dB) (Note 2)	
1	R.69 FDD	OP. 1 FD D	N/A	N/A	EP A5	EP A5	EP A5	4x2 Low	2x2 Low	2x2 Low	85	18.5	≥1
Note 1: The propagation conditions for Cell 1, Cell 2 and Cell 3 are statistically independent.													
Note 2: SNR corresponds to $\bar{E}_s/N_{oc}$ of Cell 1 as defined in clause 8.1.1.													

### 8.3.1.1D Enhanced Performance Requirement Type B – Single-layer Spatial Multiplexing with CRS interference model

The requirements are specified in Table 8.3.1.1D-2, with the addition of the parameters in Table 8.3.1.1D-1 and the downlink physical channel setup according to Annex C.3.2. The purpose of these tests is to verify closed loop rank one performance on one of the antenna ports 7 or 8 without a simultaneous transmission on the other antenna port in the serving cell when the PDSCH transmission in the serving cell is interfered by the CRS of the interfering cell, applying the CRS interference model defined in clause B.6.5. In 8.3.1.1D-1, Cell 1 is the serving cell, and Cell 2, 3 are interfering cells. The downlink physical channel setup is according to Annex C.3.2 for each of Cell 1, Cell 2 and Cell 3, respectively.

**Table 8.3.1.1D-1: Test Parameters for Testing CDM-multiplexed DM RS (Single-layer) with CRS interference model**

Parameter		Unit	Cell 1	Cell 2	Cell 3
Downlink power allocation	$\rho_A$	dB	0	0	0
	$\rho_B$	dB	0 (Note 1)	0	0
	$\sigma$	dB	-3	-3	-3
Cell-specific reference signals			Antenna ports 0,1	Antenna ports 0,1	Antenna ports 0,1
$N_{oc}$ at antenna port		dBm/15kHz	-98		
$\bar{E}_s/N_{oc}$		dB	N/A	13.91	3.34
$BW_{channel}$		MHz	10	10	10
Cyclic Prefix			Normal	Normal	Normal
Cell Id			0	1	6
Number of control OFDM symbols			3	3	3
CFI indicated in PCFICH			3	3	3
PDSCH transmission mode			8	N/A	N/A
Interference model			N/A	As specified in clause B.6.5	As specified in clause B.6.5
Precoding			Random wideband precoding per TTI	N/A	N/A
Time offset to cell 1		us	N/A	2	3
Frequency offset to cell 1		Hz	N/A	200	300
MBSFN			Not configured	Not configured	Not configured
NeighCellsInfo-r12 (Note 3)	p-aList-r12		N/A	{dB-6, dB-3, dB0}	{dB-6, dB-3, dB0}
	transmissionModelList-r12		N/A	{2,3,4,8,9}	{2,3,4,8,9}
Note 1: $P_B = 1$					
Note 2: Cell 1 is the serving cell. Cell 2, 3 are the interfering cells.					
Note 3: NeighCellsInfo-r12 is described in subclause 6.3.2 of [7].					



**Table 8.3.1.1D-2: Minimum Performance for Enhanced Performance Requirement Type B, CDM-multiplexed DM RS with CRS interference model**

Test Number	Reference Channel	OCNG Pattern			Propagation Conditions			Correlation Matrix and Antenna Configuration (Note 3)	Reference Value		UE Category
		Cell 1	Cell 2	Cell 3	Cell 1	Cell 2	Cell 3		Fraction of Maximum Throughput (%)	SNR (dB) (Note 2)	
1	R.71 FDD	OP. 1 FDD	N/A	N/A	EP A5	EP A5	EP A5	2x2 Low	85	14.3	≥2
Note 1: The propagation conditions for Cell 1, Cell 2 and Cell 3 are statistically independent. Note 2: SNR corresponds to $E_s/N_{oc}$ of Cell 1 as defined in clause 8.1.1. Note 3: Correlation matrix and antenna configuration parameters apply for each of Cell 1, Cell 2 and Cell 3.											

### 8.3.1.1E Enhanced Performance Requirement Type B – Single-layer Spatial Multiplexing with TM3 interference model

The requirements are specified in Table 8.3.1.1E-2, with the addition of the parameters in Table 8.3.1.1E-1 and the downlink physical channel setup according to Annex C.3.2. The purpose of these tests is to verify closed loop rank one performance on one of the antenna ports 7 or 8 without a simultaneous transmission on the other antenna port in the serving cell when the PDSCH transmission in the serving cell is interfered by PDSCH of two interfering cells applying transmission mode 3 interference model defined in clause B.6.2. In 8.3.1.1E-1, Cell 1 is the serving cell, and Cell 2, 3 are interfering cells. The downlink physical channel setup is according to Annex C.3.2 for each of Cell 1, Cell 2 and Cell 3, respectively.

**Table 8.3.1.1E-1: Test Parameters for Testing CDM-multiplexed DM RS (Single-layer) with TM3 interference model**

Parameter		Unit	Cell 1	Cell 2	Cell 3
Downlink power allocation	$\rho_A$	dB	0	-3	-3
	$\rho_B$	dB	0 (Note 1)	-3	-3
	$\sigma$	dB	-3	0	0
Cell-specific reference signals			Antenna ports 0,1	Antenna ports 0,1	Antenna ports 0,1
$N_{oc}$ at antenna port		dBm/15kHz	-98		
$\hat{E}_s/N_{oc}$		dB	N/A	3.28	0.74
BW <sub>channel</sub>		MHz	10	10	10
Cyclic Prefix			Normal	Normal	Normal
Cell Id			0	1	6
Number of control OFDM symbols			3	3	3
CFI indicated in PCFICH			3	Random from {1,2,3}	Random from {1,2,3}
PDSCH transmission mode			8	3	3
Interference model			N/A	As specified in clause B.6.2	As specified in clause B.6.2
Precoding			Random wideband precoding per TTI	As specified in clause B.6.2	As specified in clause B.6.2
Time offset to cell 1		us	N/A	2	3
Frequency offset to cell 1		Hz	N/A	200	300
MBSFN			Not configured	Not configured	Not configured
NeighCellsInfo-r12 (Note 4)	p-aList-r12		N/A	{dB-6, dB-3, dB0}	{dB-6, dB-3, dB0}
	transmissionModelList-r12		N/A	{2,3,4,8,9}	{2,3,4,8,9}
Note 1: $P_B = 1$					
Note 2: Cell 1 is the serving cell. Cell 2, 3 are the interfering cells.					
Note 3: CSI-RS configurations are according to [4] subclause 6.10.5.2.					
Note 4: NeighCellsInfo-r12 is described in subclause 6.3.2 of [7].					

**Table 8.3.1.1E-2: Minimum Performance for Enhanced Performance Requirement Type B, CDM-multiplexed DM RS with TM3 interference model**

Test Number	Reference Channel	OCNG Pattern			Propagation Conditions			Correlation Matrix and Antenna Configuration (Note 3)	Reference Value		UE Category
		Cell 1	Cell 2	Cell 3	Cell 1	Cell 2	Cell 3		Fraction of Maximum Throughput (%)	SNR (dB) (Note 2)	
1	R.70 FDD	OP. 1 FDD	N/A	N/A	EP A5	EP A5	EP A5	2x2 Low	85	11.5	≥1
Note 1: The propagation conditions for Cell 1, Cell 2 and Cell 3 are statistically independent.											
Note 2: SNR corresponds to $E_s/N_{oc}$ of Cell 1 as defined in clause 8.1.1.											
Note 3: Correlation matrix and antenna configuration parameters apply for each of Cell 1, Cell 2 and Cell 3.											

### 8.3.1.1F Enhanced Performance Requirement Type B – Single-layer Spatial Multiplexing with TM10 serving cell configuration and TM9 interference model

The requirements are specified in Table 8.3.1.1F-2, with the addition of the parameters in Table 8.3.1.1F-1 and the downlink physical channel setup according to Annex C.3.2. The purpose of these tests is to verify closed loop rank one

performance on one of the antenna ports 7 or 8 without a simultaneous transmission on the other antenna port in the serving cell when the PDSCH transmission configured with TM10 in the serving cell is interfered by PDSCH of one dominant interfering cell applying transmission mode 9 interference model defined in clause B.6.3. The NAICS network assistance is provided when the serving cell TM10 is configured with QCL-type A and PCID based DM-RS scrambling. The neighbouring cell has transmission mode TM9 and NeighCellsInfo-r12 for interfering cell indicates presence of TM9. In 8.3.1.1F-1, Cell 1 is the serving cell, and Cell 2, 3 are interfering cells. The downlink physical channel setup is according to Annex C.3.2 for each of Cell 1, Cell 2 and Cell 3, respectively.

**Table 8.3.1.1F-1: Test Parameters for Testing CDM-multiplexed DM RS (single layer) with TM10 serving cell configuration and TM9 interference model**

Parameter		Unit	Cell 1	Cell 2	Cell 3
Downlink power allocation	$\rho_A$	dB	0	0	0
	$\rho_B$	dB	0 (Note 1)	0	0
	$\sigma$	dB	-3	-3	-3
Cell-specific reference signals			Antenna ports 0,1	Antenna ports 0,1	Antenna ports 0,1
$N_{oc}$ at antenna port		dBm/15kHz	-98		
$E_s/N_{oc}$		dB	N/A	13.91	3.34
BW <sub>channel</sub>		MHz	10	10	10
Cyclic Prefix			Normal	Normal	Normal
Cell Id			0	1	6
Number of control OFDM symbols			3	3	3
CFI indicated in PCFICH			3	3	3
PDSCH transmission mode			10	9	9
Interference model			N/A	As specified in clause B.6.4	As specified in clause B.6.4
Precoding			Random wideband precoding per TTI	As specified in clause B.6.4	As specified in clause B.6.4
CSI reference signals			Antenna ports 15, 16, 17, 18	Antenna ports 15, 16	Antenna ports 15, 16
CSI-RS periodicity and subframe offset $T_{CSI-RS} / \Delta_{CSI-RS}$		Subframes	10 / 1	10 / 1	10 / 1
CSI reference signal configuration			5	6	7
Zero-power CSI-RS configuration $l_{CSI-RS} / \text{ZeroPowerCSI-RS}$ bitmap		Subframes / bitmap	6 / 10000000000 00000	6 / 010000000000 0000	6 / 00100000000 00000
Time offset to cell 1		us	N/A	2	3
Frequency offset to cell 1		Hz	N/A	200	300
MBSFN			Not configured	Not configured	Not configured
NeighCellsInfo-r12 (Note 4)	p-aList-r12		N/A	{dB-6, dB-3, dB0}	{dB-6, dB-3, dB0}
	transmissionModelList-r12		N/A	{2,3,4,8,9}	{2,3,4,8,9}
Note 1: $P_B = 1$					
Note 2: Cell 1 is the serving cell. Cell 2, 3 are the interfering cells.					
Note 3: CSI-RS configurations are according to [4] subclause 6.10.5.2.					
Note 4: NeighCellsInfo-r12 is described in subclause 6.3.2 of [7].					

**Table 8.3.1.1F-2: Minimum Performance for Enhanced Performance Requirement Type B, CDM-multiplexed DM RS with TM10 serving cell configuration and TM9 interference model**

Test Number	Reference Channel	OCNG Pattern			Propagation Conditions			Correlation Matrix and Antenna Configuration			Reference Value		UE Category
		Cell 1	Cell 2	Cell 3	Cell 1	Cell 2	Cell 3	Cell 1	Cell 2	Cell 3	Fraction of Maximum Throughput (%)	SNR (dB) (Note 2)	
1	R.69 FDD	OP. 1 FDD	N/A	N/A	EP A5	EP A5	EP A5	4x2 Low	2x2 Low	2x2 Low	85	18.2	≥1

Note 1: The propagation conditions for Cell 1, Cell 2 and Cell 3 are statistically independent.

Note 2: SINR corresponds to  $E_s/N_{oc}$  of Cell 1 as defined in clause 8.1.1.

### 8.3.1.1G Single-layer Spatial Multiplexing (CRS assistance information is configured)

The requirements are specified in Table 8.3.1.1G-2, with the addition of parameters in Table 8.3.1.1G-1. The purpose is to verify the performance of the antenna ports 7 or 8 without a simultaneous transmission on the other antenna port in the serving cell with CRS assistance information. In Table 8.3.1.1G-1, Cell 1 is the serving cell, and Cell 2 and Cell 3 are the aggressor cells. The downlink physical channel setup for Cell 1, Cell 2 and Cell 3 is according to Annex C.3.2. The CRS assistance information [7] includes Cell 2 and Cell 3.

Table 8.3.1.1G-1: Test parameters of TM9-Single-Layer (2 CSI-RS ports)

Parameter		Unit	Cell 1	Cell 2	Cell 3
Downlink power allocation	$\rho_A$	dB	0	0	0
	$\rho_B$	dB	0 (Note 1)	0 (Note 1)	0 (Note 1)
	$\sigma$	dB	-3	-3	-3
$N_{oc}$ at antenna port		dBm/15kHz	-98	N/A	N/A
$\bar{E}_s/N_{oc}$		dB	Reference Value in Table 8.3.1.1G-2	10.45	4.6
$BW_{Channel}$		MHz	10	10	10
Subframe Configuration			Non-MBSFN	Non-MBSFN	Non-MBSFN
Time Offset to Cell 1		$\mu$ s	N/A	3	-1
Frequency shift to Cell 1		Hz	N/A	300	-100
Cell Id			0	1	128
Cell-specific reference signals			Antenna ports 0,1		
CSI reference signals			Antenna ports 15,16	N/A	N/A
CSI-RS periodicity and subframe offset $T_{CSI-RS} / \Delta_{CSI-RS}$		Subframes	5 / 2	N/A	N/A
CSI reference signal configuration			8	N/A	N/A
Zero-power CSI-RS configuration $I_{CSI-RS} / ZeroPowerCSI-RS$ bitmap		Subframes / bitmap	3 / 001000000000000	N/A	N/A
Number of control OFDM symbols			2	2	2
PDSCH transmission mode			TM9-1layer	N/A	N/A
Precoding granularity			Frequency domain: 1 PRG Time domain: 1 ms	N/A	N/A
Beamforming model			Annex B.4.1	N/A	N/A
Interference model			N/A	As specified in clause B.5.4	As specified in clause B.5.4
Probability of occurrence of transmission in interference cells		%	N/A	20	20
Probability of occurrence of transmission rank in interfering cells	Rank 1	%	N/A	80	80
	Rank 2	%	N/A	20	20
Cyclic prefix			Normal	Normal	Normal
<p>Note 1: <math>P_{\rho} = 1</math>.</p> <p>Note 2: If the UE reports in an available uplink reporting instance at subframe SF#n based on PMI estimation at a downlink SF not later than SF#(n-4), this reported PMI cannot be applied at the eNB downlink before SF#(n+4).</p> <p>Note 3: The number of the CRS ports in Cell 1, Cell 2 and Cell 3 is the same.</p> <p>Note 4: SIB-1 will not be transmitted in Cell 2 and Cell 3 in this test.</p> <p>Note 5: The modulation symbols of the signal under test are mapped onto antenna port 7 or 8.</p>					

Table 8.3.1.1G-2: Minimum Performance of TM9-Single-Layer (2 CSI-RS ports)

Test Number	Reference Channel	OCNG Pattern			Propagation Conditions (Note1)			Correlation Matrix and Antenna Configuration (Note 2)	Reference Value		UE Category
		Cell 1	Cell 2	Cell 3	Cell 1	Cell 2	Cell 3		Fraction of Maximum Throughput (%)	SNR (dB) (Note 3)	
1	R.51-1 FDD	OP.1 FDD	N/A	N/A	EVA5			2x2 Low	70	11.6	≥2

Note 1: The propagation conditions for Cell 1, Cell 2 and Cell 3 are statistically independent.  
Note 2: The correlation matrix and antenna configuration apply for Cell 1, Cell 2 and Cell 3.  
Note 3: SNR corresponds to  $\hat{E}_s/N_{oc}$  of cell 1.

### 8.3.1.1H Single-layer Spatial Multiplexing (With Enhanced DMRS table configured)

For single-layer transmission on antenna port 7, 8, 11 or 13 upon detection of a PDCCH with DCI format 2C, the requirement is specified in Table 8.3.1.1H-2, with the addition of the parameters in Table 8.3.1.1H-1 and the downlink physical channel setup according to Annex C.3.2. The purpose of the test is to verify rank-1 performance on antenna port 11 with a simultaneous transmission on the antenna port 7, 8 or 13 with DMRS enhancement table and 4 orthogonal DMRS ports (dmrs-Enhancements-r13 UE-EUTRA-Capability [7]).

**Table 8.3.1.1H-1: Test Parameters for Testing CDM-multiplexed DM RS (single layer) with interfering simultaneous transmission (FRC) with multiple CSI-RS configurations with Enhanced DMRS table**

parameter	Unit	Test 1	
Downlink power allocation	$\rho_A$	dB	0
	$\rho_B$	dB	0 (Note 1)
	$\sigma$	dB	-3
Beamforming model		Annex B.4.1A	
Cell-specific reference signals		Antenna ports 0,1	
CSI reference signals		Antenna ports 15,...,18	
CSI-RS periodicity and subframe offset $T_{\text{CSI-RS}} / \Delta_{\text{CSI-RS}}$	Subframes	5 / 2	
CSI reference signal configuration		3	
Zero-power CSI-RS configuration $I_{\text{CSI-RS}} / \text{ZeroPowerCSI-RS bitmap}$	Subframes / bitmap	3 / 0001000000000000	
$N_{oc}$ at antenna port	dBm/15kHz	-98	
Symbols for unused PRBs		OCNG (Note 4)	
Number of allocated resource blocks (Note 2)	PRB	50	
Simultaneous transmission		Yes (Note 3, 5)	
dmsr-Enhancements-r13		Enable	
PDSCH transmission mode		9	
Note 1: $P_B = 1$ . Note 2: The modulation symbols of the signal under test are mapped onto antenna port 11. Note 3: Modulation symbols of an interference signal are random mapped onto one antenna port among antenna port 7, 8 and 13. The update granularity for randomized mapping antenna port is 1 PRG in frequency domain and 1ms in time domain. Note 4: These physical resource blocks are assigned to an arbitrary number of virtual UEs with one PDSCH per virtual UE; the data transmitted over the OCNG PDSCHs shall be uncorrelated pseudo random data, which is QPSK modulated. Note 5: The two UEs' scrambling identities $n_{\text{SCID}}$ are set to 0 with OCC =4.			

**Table 8.3.1.1H-2: Minimum performance for CDM-multiplexed DM RS with interfering simultaneous transmission (FRC) with multiple CSI-RS configurations with Enhanced DMRS table**

Test number	Bandwidth and MCS	Reference Channel	OCNG Pattern	Propagation Condition	Correlation Matrix and Antenna Configuration	Reference value		UE Category
						Fraction of Maximum Throughput (%)	SNR (dB)	
1	10 MHz 64QAM 1/2	R.50 FDD	OP.1 FDD	EPA5	2x2 Low	70	21.9	≥2
Note 1: The reference channel applies to both the input signal under test and the interfering signal.								

### 8.3.1.1I Single-layer Spatial Multiplexing (with assistance information for simultaneous transmission interfering PDSCH)

For single-layer transmission on a DMRS antenna port upon detection of a PDCCH with DCI format 2C, the requirements are specified in Table 8.3.1.1I-1, with the addition of the parameters in Table 8.3.1.1I-2 and the downlink

physical channel setup according to Annex C.3.2. The purpose of these tests is to verify rank-1 performance on one DMRS antenna port with a simultaneous transmission on one of the other DMRS antenna port with or without DMRS enhancement table and 4 orthogonal DMRS ports (dmrs-Enhancements-r13 UE-EUTRA-Capability [7]).

**Table 8.3.1.1I-1: Test Parameters for Minimum Performance Requirement - Single-layer Spatial Multiplexing with assistance information for simultaneous transmission interfering PDSCH (FRC)**

parameter	Unit	Test 1	Test 2	Test 3
Downlink power allocation	$\rho_A$	dB		
	$\rho_B$	dB		
	$\sigma$	dB		
Beamforming model		Annex B.4.1		
Cell-specific reference signals		Antenna ports 0,1		
CSI reference signals		Antenna ports 15,...,18		
CSI-RS periodicity and subframe offset $T_{\text{CSI-RS}} / \Delta_{\text{CSI-RS}}$	Subframes	5 / 2		
CSI reference signal configuration		3		
Zero-power CSI-RS configuration $l_{\text{CSI-RS}} /$ <i>ZeroPowerCSI-RS</i> bitmap	Subframes / bitmap	3 / 0001000000000000		
$N_{oc}$ at antenna port	dBm/15kHz	-98		
Symbols for unused PRBs		OCNG (Note 2)		
Number of allocated resource blocks	PRB	50		
Simultaneous transmission		Yes		
PDSCH transmission mode		9		
Number of MBSFN subframes	Subframes	NA		
dmrs-Enhancements-r13		Disabled	Enable	Enable
k-max-r14 (Note 5)		1	1	3
Note 1: $P_B = 1$ .				
Note 2: These physical resource blocks are assigned to an arbitrary number of virtual UEs with one PDSCH per virtual UE; the data transmitted over the OCNG PDSCHs shall be uncorrelated pseudo random data, which is QPSK modulated.				
Note 3: In Test 1, the modulation symbols of the signal under test are mapped randomly onto antenna port 7 or 8. Modulation symbols of an interference signal are mapped randomly onto one of the remaining DMRS antenna port. The two UEs' scrambling identities $n_{\text{SCID}}$ are set to 0 with OCC =2.				
Note 4: In Test 2 and Test 3, the modulation symbols of the signal under test are mapped randomly onto antenna port 7, 8, 11 or 13. Modulation symbols of an interference signal are mapped randomly onto one of the remaining DMRS antenna port. The two UEs' scrambling identities $n_{\text{SCID}}$ are set to 0 with OCC =4.				
Note 5: k-max-r14 is described in subclause 6.3.2 of [7].				
Note 6: The update granularity for randomized mapping antenna port is 50 PRGs in frequency domain and 1ms in time domain.				

**Table 8.3.1.1I-2: Minimum performance for Minimum Performance Requirement - Single-layer Spatial Multiplexing with assistance information for simultaneous transmission interfering PDSCH (FRC)**

Test number	Bandwidth	Reference Channel	OCNG Pattern	Propagation Condition	Correlation Matrix and Antenna Configuration	Reference value		UE Category
						Fraction of Maximum Throughput (%)	SNR (dB)	
1	10 MHz	R.cc FDD	OP.1 FDD	EPA5	4x2 Low	70	15.2	$\geq 2$
2								
3								



### 8.3.1.2 Dual-Layer Spatial Multiplexing

For dual-layer transmission on antenna ports 7 and 8 upon detection of a PDCCH with DCI format 2C, the requirements are specified in Table 8.3.1.2-2, with the addition of the parameters in Table 8.3.1.2-1 where Cell 1 is the serving cell and Cell 2 is the interfering cell. The downlink physical channel setup is set according to Annex C.3.2. The purpose of these tests is to verify the rank-2 performance for full RB allocation, to verify rate matching with multiple CSI reference symbol configurations with non-zero and zero transmission power, and to verify that the UE correctly estimate SNR.

**Table 8.3.1.2-1: Test Parameters for Testing CDM-multiplexed DM RS (dual layer) with multiple CSI-RS configurations**

Parameter	Unit	Test 1		
		Cell 1	Cell 2	
Downlink power allocation	$\rho_A$	dB	0	0
	$\rho_B$	dB	0 (Note 1)	0
	$\sigma$	dB	-3	-3
	PDSCH_RA	dB	4	NA
	PDSCH_RB	dB	4	NA
Cell-specific reference signals		Antenna ports 0 and 1	Antenna ports 0 and 1	
Cell ID		0	126	
CSI reference signals		Antenna ports 15,16	NA	
Beamforming model		Annex B.4.2	NA	
CSI-RS periodicity and subframe offset $T_{\text{CSI-RS}} / \Delta_{\text{CSI-RS}}$	Subframes	5 / 2	NA	
CSI reference signal configuration		8	NA	
Zero-power CSI-RS configuration $l_{\text{CSI-RS}} / \text{ZeroPowerCSI-RS}$ bitmap	Subframes / bitmap	3 / 0010000000000000	NA	
$N_{oc}$ at antenna port	dBm/15kHz	-98	-98	
$E_s / N_{oc}$		Reference Value in Table 8.3.1.2-2	7.25dB	
Symbols for unused PRBs		OCNG (Note 2)	NA	
Number of allocated resource blocks (Note 2)	PRB	50	NA	
Simultaneous transmission		No	NA	
PDSCH transmission mode		9	Blanked	
Note 1: $P_B = 1$				
Note 2: These physical resource blocks are assigned to an arbitrary number of virtual UEs with one PDSCH per virtual UE; the data transmitted over the OCNG PDSCHs shall be uncorrelated pseudo random data, which is QPSK modulated.				

**Table 8.3.1.2-2: Minimum performance for CDM-multiplexed DM RS (FRC) with multiple CSI-RS configurations**

Test number	Bandwidth and MCS	Reference Channel	OCNG Pattern		Propagation Condition		Correlation Matrix and Antenna Configuration	Reference value		UE Category
			Cell 1	Cell 2	Cell 1	Cell 2		Fraction of Maximum Throughput (%)	SNR (dB)	
1	10 MHz 16QAM 1/2	R.51 FDD	OP.1 FDD	N/A	ETU5	ETU5	2x2 Low	70	14.2	$\geq 2$

Note 1: The propagation conditions for Cell 1 and Cell 2 are statistically independent.  
Note 2: Correlation matrix and antenna configuration parameters apply for each of Cell 1 and Cell 2.  
Note 3: SNR corresponds to  $\bar{E}_s/N_{oc}$  of Cell 1.

### 8.3.1.2A Enhanced Performance Requirement Type C - Dual-Layer Spatial Multiplexing

The requirements are specified in Table 8.3.1.2A-2, with the addition of the parameters in Table 8.3.1.2A-1 and the downlink physical channel setup according to Annex C.3.2. The purpose of this test is to verify rank two performance for full RB allocation upon antenna ports 7 and 8.

**Table 8.3.1.2A-1: Test Parameters for Testing CDM-multiplexed DM RS (dual layer) with multiple CSI-RS configurations**

parameter	Unit	Test 1	
Downlink power allocation	$\rho_A$	dB	0
	$\rho_B$	dB	0 (Note 1)
	$\sigma$	dB	-3
Cell-specific reference signals		Antenna ports 0 and 1	
CSI reference signals		Antenna ports 15,16	
Beamforming model		Annex B.4.2	
CSI-RS periodicity and subframe offset $T_{\text{CSI-RS}} / \Delta_{\text{CSI-RS}}$	Subframes	5 / 2	
CSI reference signal configuration		8	
Zero-power CSI-RS configuration $l_{\text{CSI-RS}} / \text{ZeroPowerCSI-RS bitmap}$	Subframes / bitmap	3 / 0010000000000000	
$N_{oc}$ at antenna port	dBm/15kHz	-98	
Symbols for unused PRBs		OCNG (Note 2)	
Number of allocated resource blocks (Note 2)	PRB	50	
Simultaneous transmission		No	
PDSCH transmission mode		9	
Note 1: $P_b = 1$			
Note 2: These physical resource blocks are assigned to an arbitrary number of virtual UEs with one PDSCH per virtual UE; the data transmitted over the OCNG PDSCHs shall be uncorrelated pseudo random data, which is QPSK modulated.			

**Table 8.3.1.2A-2: Enhanced Performance Requirement Type C for CDM-multiplexed DM RS (FRC) with multiple CSI-RS configurations**

Test number	Bandwidth and MCS	Reference Channel	OCNG Pattern	Propagation Condition	Correlation Matrix and Antenna Configuration	Reference value		UE Category
						Fraction of Maximum Throughput (%)	SNR (dB)	
1	10 MHz 16QAM 1/2	R.51 FDD	OP.1 FDD	EPA5	2x2 Medium	70	17.4	≥2

### 8.3.1.3 Performance requirements for DCI format 2D and non Quasi Co-located Antenna Ports

#### 8.3.1.3.1 Minimum requirement with Same Cell ID (with single NZP CSI-RS resource)

The requirements are specified in Table 8.3.1.3.1-3, with the additional parameters in Table 8.3.1.3.1-1 and Table 8.3.1.3.1-2. The purpose of this test is to verify the UE capability of supporting non quasi-co-located antenna ports when the UE receives DCI format 2D in a scenario where the two transmission point share the same Cell ID. In particular the test verifies that the UE, configured with quasi co-location type B, performs correct tracking and compensation of the timing difference between two transmission points, channel parameters estimation and rate matching according to the 'PDSCH RE Mapping and Quasi-Co-Location Indicator' (PQI) signalling defined in [6], configured according to Table 8.3.1.3.1-2. In Tables 8.3.1.3.1-1 and 8.3.1.3.1-2, transmission point 1 (TP 1) is the serving cell and transmission point 2 (TP 2) transmits PDSCH. The downlink physical channel setup for TP 1 is according to Table C.3.4-1 and for TP 2 according to Table C.3.4-2.

**Table 8.3.1.3.1-1: Test Parameters for quasi co-location type B: same Cell ID**

Parameter	Unit	TP 1	TP 2
Downlink power allocation	$\rho_A$	dB	0
	$\rho_B$	dB	0 (Note 1)
	$\sigma$	dB	-3
Cell-specific reference signals		Antenna ports 0,1	(Note 2)
CSI-RS 0 antenna ports		NA	Port {15,16}
<i>qcl-CSI-RS-ConfigNZPId-r11</i> , CSI-RS 0 periodicity and subframe offset $T_{\text{CSI-RS}} / \Delta_{\text{CSI-RS}}$	Subframes	NA	5/2
<i>qcl-CSI-RS-ConfigNZPId-r11</i> , CSI-RS 0 configuration		NA	8
<i>csi-RS-ConfigZPId-r11</i> , Zero-power CSI-RS 0 configuration $I_{\text{CSI-RS}} / \text{ZeroPower CSI-RS bitmap}$		NA	2/ 0000010000000000
$N_{oc}$ at antenna port	dBm/15kHz	-98	-98
$E_s / N_{oc}$	dB	Reference point in Table 8.3.1.3.1-3	Reference point in Table 8.3.1.3.1-3
$BW_{\text{Channel}}$	MHz	10	10
Cyclic Prefix		Normal	Normal
Cell Id		0	0
Number of control OFDM symbols		2	2
PDSCH transmission mode		Blanked	10
Number of allocated PRB	PRB	NA	50
<i>qcl-Operation</i> , 'PDSCH RE Mapping and Quasi-Co-Location Indicator'		Type B, '00'	
Time offset between TPs	$\mu\text{s}$	NA	Reference point in Table 8.3.1.3.1-3
Frequency error between TPs	Hz	NA	0
Beamforming model		NA	Port 7 as specified in clause B.4.1
Symbols for unused PRBs		NA	OCNG (Note 3)
Note 1: $P_B = 1$ Note 2: REs for antenna ports 0 and 1 have zero transmission power. Note 3: These physical resource blocks are assigned to an arbitrary number of virtual UEs with one PDSCH per virtual UE; the data transmitted over the OCNG PDSCHs shall be uncorrelated pseudo random data, which is QPSK modulated.			

**Table 8.3.1.3.1-2: Configurations of PQI and DL transmission hypothesis for each PQI set**

PQI set index	Parameters in each PQI set		DL transmission hypothesis for each PQI Set	
	NZP CSI-RS Index (For quasi co-location)	ZP CSI-RS configuration	TP 1	TP 2
PQI set 0	CSI-RS 0	ZP CSI-RS 0	Blanked	PDSCH

Table 8.3.1.3.1-3: Minimum performance for quasi co-location type B: same Cell ID

Test Number	Reference Channel	OGCN pattern		Time offset between TPs ( $\mu$ s)	Propagation Conditions (Note 1)		Correlation Matrix and Antenna Configuration (Note 2)	Reference Value		UE Category
		TP 1	TP 2		TP 1	TP 2		Fraction of Maximum Throughput (%)	SNR (dB) (Note 3)	
1	R.52 FDD	NA	OP.1 FDD	2	EPA5	EPA5	2x2 Low	70	12.1	$\geq 2$
2	R.52 FDD	NA	OP.1 FDD	-0.5	EPA5	EPA5	2x2 Low	70	12.6	$\geq 2$

Note 1: The propagation conditions for TP 1 and TP 2 are statistically independent.  
Note 2: The correlation matrix and antenna configuration apply for TP 1 and TP 2.  
Note 3: SNR corresponds to  $\hat{E}_s / N_{oc}$  of TP 2 as defined in clause 8.1.1.

### 8.3.1.3.2 Minimum requirements with Same Cell ID (with multiple NZP CSI-RS resources)

The requirements are specified in Table 8.3.1.3.2-3, with the additional parameters in Tables 8.3.1.3.2-1 and 8.3.1.3.2-2. The purpose of this test is to verify the UE capability of supporting non quasi-co-located antenna ports when the UE receives DCI format 2D in a scenario where the two transmission point share the same Cell ID. In particular the test verifies that the UE, configured with quasi co-location type B, performs correct tracking and compensation of the timing difference between two transmission points, channel parameters estimation and rate matching according to the 'PDSCH RE Mapping and Quasi-Co-Location Indicator' (PQI) signalling defined in [6]. In Tables 8.3.1.3.2-1 and 8.3.1.3.2-2, transmission point 1 (TP 1) is the serving cell transmitting PDCCH, synchronization signals and PBCH, and transmission point 2 (TP 2) has same Cell ID as TP 1. Multiple NZP CSI-RS resources and ZP CSI-RS resources are configured. In each sub-frame, DL PDSCH transmission is dynamically switched between 2 TPs with multiple PDSCH RE Mapping and Quasi-Co-Location Indicator configuration (PQI). Configurations of PDSCH RE Mapping and Quasi-Co-Location Indicator and downlink transmission hypothesis are defined in Table 8.3.1.3.2-2. The downlink physical channel setup for TP 1 is according to Table C.3.4-1 and for TP 2 according to Table C.3.4-2.

Table 8.3.1.3.2-1: Test Parameters for timing offset compensation with DPS transmission

parameter		Unit	TP 1	TP 2
Downlink power allocation	$\rho_A$	dB	0	0
	$\rho_B$	dB	0 (Note 1)	0
	$\sigma$	dB	-3	-3

Beamforming model		As specified in clause B.4.1	As specified in clause B.4.1
Cell-specific reference signals		Antenna ports 0,1	(Note 2)
CSI reference signals 0		Antenna ports {15,16}	N/A
CSI-RS 0 periodicity and subframe offset $T_{\text{CSI-RS}} / \Delta_{\text{CSI-RS}}$	Subframes	5 / 2	N/A
CSI reference signal 0 configuration		0	N/A
CSI reference signals 1		N/A	Antenna ports {15,16}
CSI-RS 1 periodicity and subframe offset $T_{\text{CSI-RS}} / \Delta_{\text{CSI-RS}}$	Subframes	N/A	5 / 2
CSI reference signal 1 configuration		N/A	8
Zero-power CSI-RS 0 configuration $l_{\text{CSI-RS}} / \text{ZeroPower CSI-RS bitmap}$	Subframes /bitmap	2/ 0010000000000000	N/A
Zero-power CSI-RS1 configuration $l_{\text{CSI-RS}} / \text{ZeroPower CSI-RS bitmaps}$	Subframes /bitmap	N/A	2/ 0000010000000000
$E_s / N_{oc}$	dB	Reference Value in Table 8.3.1.3.2-3	Reference Value in Table 8.3.1.3.2-3
$N_{oc}$ at antenna port	dBm/15kHz	-98	-98
$BW_{\text{Channel}}$	MHz	10	10
Cyclic Prefix		Normal	Normal
Cell Id		0	0
Number of control OFDM symbols		2	2
Timing offset between TPs		N/A	Reference Value in Table 8.3.1.3.2-3
Frequency offset between TPs	Hz	N/A	0
Number of allocated resource blocks	PRB	50	50
PDSCH transmission mode		10	10
Probability of occurrence of PDSCH transmission(Note 3)	%	30	70
Symbols for unused PRBs		OCNG (Note 4)	OCNG (Note 4)
<p>Note 1: <math>P_B = 1</math></p> <p>Note 2: REs for antenna ports 0 and 1 have zero transmission power.</p> <p>Note 3: PDSCH transmission from TPs shall be randomly determined independently for each subframe. Probabilities of occurrence of PDSCH transmission from TPs are specified.</p> <p>Note 4: These physical resource blocks are assigned to an arbitrary number of virtual UEs with one PDSCH per virtual UE; the data transmitted over the OCNG PDSCHs shall be uncorrelated pseudo random data, which is QPSK modulated.</p>			

Table 8.3.1.3.2-2: Configurations of PQI and DL transmission hypothesis for each PQI set

PQI set index	Parameters in each PQI set		DL transmission hypothesis for each PQI Set	
	NZP CSI-RS Index (For quasi co-location)	ZP CSI-RS configuration	TP 1	TP 2
PQI set 0	CSI-RS 0	ZP CSI-RS 0	PDSCH	Blanked
PQI set 3	CSI-RS 1	ZP CSI-RS 1	Blanked	PDSCH

Table 8.3.1.3.2-3: Performance Requirements for timing offset compensation with DPS transmission

Test Number	Timing offset(us)	Reference Channel	OCNG Pattern		Propagation Conditions		Correlation Matrix and Antenna Configuration (Note 2)	Reference Value		UE Category
			TP 1	TP 2	TP 1	TP 2		Fraction of Maximum Throughput (%)	SNR (dB) (Note 3)	
1	2	R.53 FDD	OP.1 FDD	OP.1 FDD	EPA5	EPA5	2x2 Low	70	12.2	≥2
2	-0.5	R.53 FDD	OP.1 FDD	OP.1 FDD	EPA5	EPA5	2x2 Low	70	12.5	≥2

Note 1: The propagation conditions for TP 1 and TP 2 are statistically independent.  
Note 2: Correlation matrix and antenna configuration parameters apply for each of TP 1 and TP 2.  
Note 3: SNR corresponds to  $E_s/N_{oc}$  of both TP 1 and TP 2 as defined in clause 8.1.1.

### 8.3.1.3.3 Minimum requirement with Different Cell ID and Colliding CRS (with single NZP CSI-RS resource)

The requirements are specified in Table 8.3.1.3.3-2, with the additional parameters in Table 8.3.1.3.3-1. The purpose of this test is to verify the UE capability of supporting non quasi-co-located antenna ports when the UE receives DCI format 2D in a scenario where the two transmission points have different Cell ID and colliding CRS. In particular the test verifies that the UE, configured with quasi co-location type B, performs correct tracking and compensation of the frequency difference between two transmission points, channel parameters estimation and rate matching behaviour according to the 'PDSCH RE Mapping and Quasi-Co-Location Indicator' signalling defined in [6]. In Table 8.3.1.3.3-1, transmission point 1 (TP 1) is serving cell transmitting PDCCH, synchronization signals and PBCH, and transmission point 2 (TP 2) transmits PDSCH with different Cell ID. The downlink physical channel setup for TP 1 is according to Table C.3.4-1 and for TP 2 according to Table C.3.4-2.

Table 8.3.1.3.3-1: Test Parameters for quasi co-location type B with different Cell ID and Colliding CRS

parameter	Unit	TP 1	TP 2
Downlink power allocation	$\rho_A$	dB	0
	$\rho_B$	dB	0 (Note 1)
	$\sigma$	dB	-3

Beamforming model		N/A	As specified in clause B.4.2
Cell-specific reference signals		Antenna ports 0,1	Antenna ports 0,1
CSI reference signals 0		N/A	Antenna ports {15,16}
CSI-RS 0 periodicity and subframe offset $T_{CSI-RS} / \Delta_{CSI-RS}$	Subframes	N/A	5 / 2
CSI reference signal 0 configuration		N/A	0
Zero-power CSI-RS 0 configuration $I_{CSI-RS} / ZeroPower\ CSI-RS\ bitmap$	Subframes /bitmap	N/A	2/ 0010000000000000
$E_s / N_{oc}$	dB	Reference point in Table 8.3.1.3.3-2 + 4dB	Reference Value in Table 8.3.1.3.3-2
$N_{oc}$ at antenna port	dBm/15kHz	-98	-98
$BW_{channel}$	MHz	10	10
Cyclic Prefix		Normal	Normal
Cell Id		0	126
Number of control OFDM symbols		1	2
Timing offset between TPs	us	N/A	0
Frequency offset between TPs	Hz	N/A	200
<i>qcl-Operation</i> , 'PDSCH RE Mapping and Quasi-Co-Location Indicator'		Type B, '00'	
PDSCH transmission mode		Blank	10
Number of allocated resource block		N/A	50
Symbols for unused PRBs		N/A	OCNG(Note2)
Note 1: $P_B = 1$			
Note 2: These physical resource blocks are assigned to an arbitrary number of virtual UEs with one PDSCH per virtual UE; the data transmitted over the OCNG PDSCHs shall be uncorrelated pseudo random data, which is QPSK modulated.			

**Table 8.3.1.3.3-2: Performance Requirements for quasi co-location type B with different Cell ID and Colliding CRS**

Test Number	Reference Channel	OCNG Pattern		Propagation Conditions (Note1)		Correlation Matrix and Antenna Configuration (Note 2)	Reference Value		UE Category
		TP 1	TP 2	TP 1	TP 2		Fraction of Maximum Throughput (%)	SNR (dB) (Note 3)	
1	R.54 FDD	N/A	OP.1 FDD	EPA5	ETU5	2x2 Low	70	14.4	≥2
Note 1: The propagation conditions for TP.1 and TP.2 are statistically independent.									
Note 2: Correlation matrix and antenna configuration parameters apply for each of TP.1 and TP.2.									
Note 3: SNR corresponds to $E_s / N_{oc}$ of TP.2 as defined in clause 8.1.1.									



#### 8.3.1.3.4 Minimum requirement with Different Cell ID and non-colliding CRS (with single NZP CSI-RS resource and CRS assistance information is configured)

The requirements are specified in Table 8.3.1.3.4-3, with the additional parameters in Table 8.3.1.3.4-1 and Table 8.3.1.3.4-2. The purpose of this test is to verify the UE capability of supporting non quasi-co-located antenna ports when the UE receives DCI format 2D in a scenario where three transmission points have different Cell ID and non-colliding CRS. In particular the test verifies that the UE, configured with quasi co-location type B, performs correct tracking and compensation of the frequency difference and time difference between two transmission points, channel parameters estimation and rate matching behaviour according to the 'PDSCH RE Mapping and Quasi-Co-Location Indicator' signalling defined in [6]. Further, the test verifies that the UE, configured with the CRS assistance information [7], can mitigate interference from CRS for demodulation. The CRS assistance information [7] includes TP 3. In Table 8.3.1.3.4-1, transmission point 1 (TP 1) is serving cell transmitting PDCCH, synchronization signals and PBCH, transmission point 2 (TP 2) transmits PDSCH with different Cell ID, and Transmission point 3 (TP 3) is the aggressor transmission point. The downlink physical channel setup for TP 1 is according to Table C.3.4-1, for TP 2 is according to Table C.3.4-2, and for TP 3 is according to Annex C.3.2.

**Table 8.3.1.3.4-1: Test Parameters for quasi co-location type B with different Cell ID and non-Colliding CRS when CRS assistance information is configured**

parameter	Unit	TP 1	TP 2	TP 3
Downlink power allocation	$\rho_A$	dB	0	0
	$\rho_B$	dB	0 (Note 1)	0
	$\sigma$	dB	-3	-3
Beamforming model		N/A	Port 7 as specified in clause B.4.1	N/A
Cell-specific reference signals		Antenna ports 0,1	Antenna ports 0,1	Antenna ports 0,1
CSI reference signals 0		N/A	Antenna ports {15,16}	N/A
CSI-RS 0 periodicity and subframe offset $T_{CSI-RS} / \Delta_{CSI-RS}$	Subframes	N/A	5 / 2	N/A
CSI reference signal 0 configuration		N/A	0	N/A
Zero-power CSI-RS 0 configuration $l_{CSI-RS} / \text{ZeroPower CSI-RS bitmap}$	Subframes /bitmap	N/A	2/ 0010000000000000	N/A
$E_s / N_{oc}$	dB	10.45	Reference Value in Table 8.3.1.3.4-3	8.45
$N_{oc}$ at antenna port	dBm/15kHz	-98	-98	N/A
$BW_{channel}$	MHz	10	10	10
Cyclic Prefix		Normal	Normal	Normal
Cell Id		0	1	128
Number of control OFDM symbols		1	2	2
Timing offset to TP 1	us	N/A	-0.5	3
Frequency offset to TP 1	Hz	N/A	200	-100
<i>qcl-Operation</i> , 'PDSCH RE Mapping and Quasi-Co-Location Indicator'		Type B, '00'		N/A
PDSCH transmission mode		Blank	10	9
Number of allocated resource block		N/A	50	N/A
Symbols for unused PRBs		N/A	OCNG(Note2)	N/A
Interference model		N/A	N/A	As specified in clause B.5.4
Probability of occurrence of transmission in interference cells	%	N/A	N/A	20
Probability of occurrence of transmission rank in interfering cells	Rank 1	%	N/A	80
	Rank 2	%	N/A	20
Note 1: $P_B = 1$ Note 2: These physical resource blocks are assigned to an arbitrary number of virtual UEs with one PDSCH per virtual UE; the data transmitted over the OCNG PDSCHs shall be uncorrelated pseudo random data, which is QPSK modulated.				

Table 8.3.1.3.4-2: Configurations of PQI and DL transmission hypothesis for each PQI set

PQI set index	Parameters in each PQI set		DL transmission hypothesis for each PQI Set	
	NZP CSI-RS Index (For quasi co-location)	ZP CSI-RS configuration	TP 1	TP 2
PQI set 0	CSI-RS 0	ZP CSI-RS 0	Blanked	PDSCH

Table 8.3.1.3.4-3: Performance Requirements for quasi co-location type B with different Cell ID and non-Colliding CRS when CRS assistance information is configured

Test Number	Reference Channel	OCNG Pattern			Propagation Conditions (Note1)			Correlation Matrix and Antenna Configuration (Note 2)	Reference Value		UE Category
		TP 1	TP 2	TP3	TP 1	TP 2	TP3		Fraction of Maximum Throughput (%)	SNR (dB) (Note 3)	
1	R.52-1 FDD	N/A	OP.1 FDD	N/A	EVA5	EVA5	EVA5	2x2 Low	70	10.8	≥2

Note 1: The propagation conditions for TP.1, TP.2 and TP.3 are statistically independent.

Note 2: Correlation matrix and antenna configuration parameters apply for each of TP.1, TP.2 and TP.3.

Note 3: SNR corresponds to  $E_s/N_{oc}$  of TP.2 as defined in clause 8.1.1.

### 8.3.1.3.5 Minimum requirements with different Cell ID and non-colliding CRS (with multiple NZP CSI-RS resources and CRS assistance information is configured)

The requirements are specified in Table 8.3.1.3.5-3, with the additional parameters in Tables 8.3.1.3.5-1 and 8.3.1.3.5-2. The purpose of this test is to verify the UE capability of supporting non quasi-co-located antenna ports when the UE receives DCI format 2D in a scenario where three transmission points have different Cell ID and non-colliding CRS. In particular the test verifies that the UE, configured with quasi co-location type B, performs correct tracking and compensation of the frequency difference and timing difference between two transmission points, channel parameters estimation and rate matching according to the 'PDSCH RE Mapping and Quasi-Co-Location Indicator' (PQI) signalling defined in [6]. Further, the test verifies that the UE, configured with the CRS assistance information [7], can mitigate interference from CRS for demodulation. The CRS assistance information [7] includes TP 3. In Tables 8.3.1.3.5-1 and 8.3.1.3.5-2, transmission point 1 (TP 1) is the serving cell transmitting PDCCH, synchronization signals and PBCH, Transmission point 2 (TP 2) has different Cell ID as TP 1, and Transmission point 3 (TP 3) is the aggressor transmission point. Multiple NZP CSI-RS resources and ZP CSI-RS resources are configured. In each sub-frame, DL PDSCH transmission is dynamically switched between TP 1 and TP 2 with multiple PDSCH RE Mapping and Quasi-Co-Location Indicator configuration (PQI). Configurations of PDSCH RE Mapping and Quasi-Co-Location Indicator and downlink transmission hypothesis are defined in Table 8.3.1.3.5-2. The downlink physical channel setup for TP 1 is according to Table C.3.4-1, for TP 2 is according to Table C.3.4-2, and for TP 3 is according to Annex C.3.2.

**Table 8.3.1.3.5-1: Test Parameters DPS transmission with CRS assistance information**

parameter		Unit	TP 1	TP 2	TP 3
Downlink power allocation	$\rho_A$	dB	0	0	0
	$\rho_B$	dB	0 (Note 1)	0	0
	$\sigma$	dB	-3	-3	-3
Beamforming model			As specified in clause B.4.1	As specified in clause B.4.1	N/A
Cell-specific reference signals			Antenna ports 0,1	Antenna ports 0,1	Antenna ports 0,1
CSI reference signals 0			Antenna ports {15,16}	N/A	N/A
CSI-RS 0 periodicity and subframe offset $T_{\text{CSI-RS}} / \Delta_{\text{CSI-RS}}$		Subframes	5 / 2	N/A	N/A
CSI reference signal 0 configuration			0	N/A	N/A
CSI reference signals 1			N/A	Antenna ports {15,16}	N/A
CSI-RS 1 periodicity and subframe offset $T_{\text{CSI-RS}} / \Delta_{\text{CSI-RS}}$		Subframes	N/A	5 / 2	N/A
CSI reference signal 1 configuration			N/A	8	N/A
Zero-power CSI-RS 0 configuration $l_{\text{CSI-RS}} / \text{ZeroPower CSI-RS bitmap}$		Subframes /bitmap	2/ 0010000000000000	N/A	N/A
Zero-power CSI-RS1 configuration $l_{\text{CSI-RS}} / \text{ZeroPower CSI-RS bitmaps}$		Subframes /bitmap	N/A	2/ 0000010000000000	N/A
$E_s / N_{oc}$ (Note 2)		dB	Reference Value in Table 8.3.1.3.5-3	Reference Value in Table 8.3.1.3.5-3	8.45
$N_{oc}$ at antenna port		dBm/15kHz	-98	-98	N/A
$BW_{\text{Channel}}$		MHz	10	10	10
Cyclic Prefix			Normal	Normal	Normal
Cell Id			0	1	128
Number of control OFDM symbols			2	2	2
Timing offset to TP 1			N/A	-0.5	3
Frequency offset to TP 1		Hz	N/A	200	-100
Number of allocated resource blocks		PRB	50	50	N/A
PDSCH transmission mode			10	10	9
Probability of occurrence of PDSCH transmission(Note 3)		%	30	70	N/A
Symbols for unused PRBs			OCNG (Note 4)	OCNG (Note 4)	N/A
Interference model			N/A	N/A	As specified in clause B.5.4
Probability of occurrence of transmission in interference cells		%	N/A	N/A	20
Probability of occurrence of transmission rank in interfering cells	Rank 1	%	N/A	N/A	80
	Rank 2	%	N/A	N/A	20

Note 1:	$P_b = 1$
Note 2:	$E_s/N_{oc}$ of TP1 is set the same as that of TP2.
Note 3:	PDSCH transmission from TP 1 and TP 2 shall be randomly determined independently for each subframe. Probabilities of occurrence of PDSCH transmission from TPs are specified.
Note 4:	These physical resource blocks are assigned to an arbitrary number of virtual UEs with one PDSCH per virtual UE; the data transmitted over the OCNB PDSCHs shall be uncorrelated pseudo random data, which is QPSK modulated.

Table 8.3.1.3.5-2: Configurations of PQI and DL transmission hypothesis for each PQI set

PQI set index	Parameters in each PQI set		DL transmission hypothesis for each PQI Set	
	NZP CSI-RS Index (For quasi co-location)	ZP CSI-RS configuration	TP 1	TP 2
PQI set 0	CSI-RS 0	ZP CSI-RS 0	PDSCH	Blanked
PQI set 1	CSI-RS 1	ZP CSI-RS 1	Blanked	PDSCH

Table 8.3.1.3.5-3: Performance Requirements DPS transmission with CRS assistance information

Test Number	Reference Channel	OCNB Pattern			Propagation Conditions (Note1)			Correlation Matrix and Antenna Configuration (Note 2)	Reference Value		UE Category
		TP 1	TP 2	TP3	TP 1	TP 2	TP3		Fraction of Maximum Throughput (%)	SNR (dB) (Note 3)	
1	R.52-1 FDD	OP.1 FDD	OP.1 FDD	N/A	EVA5	EVA5	EVA5	2x2 Low	70	10.7	≥2

Note 1: The propagation conditions for TP.1, TP.2 and TP.3 are statistically independent.

Note 2: Correlation matrix and antenna configuration parameters apply for each of TP.1, TP.2 and TP.3.

Note 3: SNR corresponds to  $E_s/N_{oc}$  of both TP.1 and TP.2 as defined in clause 8.1.1.

### 8.3.1.3.6 Minimum requirements for QCL Type C and 2 Layers Spatial Multiplexing

The requirements are specified in Table 8.3.1.3.6-3, with the additional parameters in Table 8.3.1.3.6-1 and Table 8.3.1.3.6-2. The purpose of this test is to verify the UE capability of supporting non quasi-co-located antenna ports when the UE receives DCI format 2D in a scenario with non-coherent joint transmission from two transmission points. The test verifies that the UE configured with quasi co-location type C performs correct tracking and compensation of the frequency and time difference between two transmission points, channel parameters estimation, channel estimation and rate matching behaviour according to the 'PDSCH RE Mapping and Quasi-Co-Location Indicator' signalling defined in [6]. In Table 8.3.1.3.6-1, transmission point 1 (TP 1) is the serving cell transmitting PDCCH, synchronization signals, PBCH and PDSCH, and transmission point 2 (TP 2) has different Cell ID and transmits PDSCH. In the test the PDSCH is transmitted from TP1 and TP2. The downlink physical channel setup for TP 1 is according to Annex C.3.2 and for TP 2 according to Annex C.3.2.

Table 8.3.1.3.6-1: Test Parameters

Parameter	Unit	TP 1	TP 2
Downlink power allocation	$\rho_A$	dB	0
	$\rho_B$	dB	0 (Note 1)
	$\sigma$	dB	-3
Beamforming model		Random beamforming (rank 1)	Random beamforming (rank 1)
Cell-specific reference signals		Antenna ports 0,1	Antenna ports 0,1
CSI reference signals 0		Antenna ports {15,16}	N/A
CSI-RS 0 periodicity and subframe offset $T_{\text{CSI-RS}} / \Delta_{\text{CSI-RS}}$	Subframes	5 / 2	
CSI reference signal 0 configuration		0	
CSI reference signals 1		N/A	Antenna ports {15,16}
CSI-RS 1 periodicity and subframe offset $T_{\text{CSI-RS}} / \Delta_{\text{CSI-RS}}$	Subframes		5 / 2
CSI reference signal 1 configuration			8
Zero-power CSI-RS 0 configuration $I_{\text{CSI-RS}} / \text{ZeroPower CSI-RS}$ bitmap	Subframes/bitmap	2/ 0010000000000000	N/A
Zero-power CSI-RS1 configuration $I_{\text{CSI-RS}} / \text{ZeroPower CSI-RS}$ bitmap	Subframes/bitmap	N/A	2/ 0010000000000000
$E_s / N_{oc}$	dB	SNR1	SNR2 = SNR1
$N_{oc}$ at antenna port	dBm/15kHz	-98	-98
$BW_{\text{Channel}}$	MHz	10	10
Cyclic Prefix		Normal	Normal
Cell ID		0	126
Number of control OFDM symbols / PDSCH start		2	2
Timing offset relative to TP 1	us	N/A	2
Frequency offset relative to TP 1	Hz	N/A	200
<i>qcl-Operation</i> , 'PDSCH RE Mapping and Quasi-Co-Location Indicator'		Type C, '00'	
PDSCH transmission mode (Note 2)		10	10
Number of allocated resource block		50	50
Note 1: $P_B = 1$			
Note 2: PDSCH transmission is done from both TPs (CW1 is transmitted from TP 1 and CW2 is transmitted from TP 2)			

Table 8.3.1.3.6-2: Configurations of PQI and DL transmission hypothesis for each PQI set

PQI set index	Parameters in each PQI set		DL transmission hypothesis for each PQI Set	
	NZP CSI-RS Index (For quasi co-location)	ZP CSI-RS configuration	TP 1	TP 2
PQI set 0	CSI-RS 0 for CW1 CSI-RS 1 for CW2	ZP CSI-RS 0	PDSCH	PDSCH

Table 8.3.1.3.6-3: Performance Requirements

Test Number	Reference Channel		OCNG Pattern		Propagation Conditions (Note1)		Correlation Matrix and Antenna Configuration (Note 2)	Reference Value		UE Category
	TP 1	TP 2	TP 1	TP 2	TP 1	TP 2		Fraction of Maximum Throughput (%)	SNR1 (dB) (Note 3)	
1	R.97 FDD	R.97 FDD	OP.1F DD	OP.1F DD	EPA5	EPA5	2x2 Low	70	11.1	≥2
Note 1: The propagation conditions for TP 1 and TP 2 are statistically independent. Note 2: Correlation matrix and antenna configuration parameters apply for each of TP 1 and TP 2. Note 3: SNR corresponds to $E_s/N_{oc}$ of TP 1 and TP 2 as defined in clause 8.1.1.										

#### 8.3.1.4 Performance Requirements for semiOpenLoop transmission

The requirements are specified in Table 8.3.1.4-2, with the addition of the parameters in Table 8.3.1.4-1 and the downlink physical channel setup according to Annex C.3.2. The purpose of these tests is to verify rank one and rank two performances for full RB allocation upon antenna ports 7 and 8 with higher layer parameter *semiOpenLoop* is configured.



**Table 8.3.1.4-1: Test Parameters for Testing CDM-multiplexed DM RS (dual layer) when high layer parameter *semiOpenLoop* is configured**

parameter	Unit	Test 1	Test 2
Downlink power allocation	$\rho_A$	dB	0
	$\rho_B$	dB	0 (Note 1)
	$\sigma$	dB	-3
Cell-specific reference signals		Antenna ports 0 and 1	Antenna ports 0 and 1
CSI reference signals		Antenna ports 15,16	Antenna ports 15,16,17,18
Beamforming model		B.4.3 (Note 3)	B.4.3 (Note 3)
CSI-RS periodicity and subframe offset $T_{\text{CSI-RS}} / \Delta_{\text{CSI-RS}}$	Subframes	5 / 2	5 / 2
CSI reference signal configuration		0	0
Zero-power CSI-RS configuration $k_{\text{CSI-RS}} / \text{ZeroPowerCSI-RS bitmap}$	Subframes / bitmap	3 / 0010000000000000	3 / 0010000000000000
$N_{oc}$ at antenna port	dBm/15kHz	-98	-98
Symbols for unused PRBs		OCNG (Note 2)	OCNG (Note 2)
Number of allocated resource blocks (Note 2)	PRB	50	50
Simultaneous transmission		No	No
PDSCH transmission mode		9	9
Rank Number of PDSCH		1	2
<i>semiOpenLoop</i>		True	True
<p>Note 1: <math>P_B = 1</math></p> <p>Note 2: These physical resource blocks are assigned to an arbitrary number of virtual UEs with one PDSCH per virtual UE; the data transmitted over the OCNG PDSCHs shall be uncorrelated pseudo random data, which is QPSK modulated.</p> <p>Note 3: For 2 antenna ports {15, 16}, the precoding matrix corresponding to codebook index 0 from Table 6.3.4.2.3-1 in [4] with <math>U =</math> ;  For 4 antenna ports { 15,16,17,18 }, the precoding matrix random selected from Table 6.3.4.2.3-2 in [4] with <math>U = 2</math>.</p>			

**Table 8.3.1.4-2: Minimum Performance Requirements for CDM-multiplexed DM RS (FRC) when high layer parameter *semiOpenLoop* is configured**

Test number	Bandwidth and MCS	Reference Channel	OCNG Pattern	Propagation Condition	Correlation Matrix and Antenna Configuration	Reference value		UE Category
						Fraction of Maximum Throughput (%)	SNR (dB)	
1	10 MHz QPSK 1/3	R.86A FDD	OP.1 FDD	EVA 70Hz	2x2 Medium	70	[0.6]	$\geq 1$
2	10 MHz 16QAM 1/2	R.45A-1 FDD	OP.1 FDD	EVA 70Hz	4x2 Low	70	[14.9]	$\geq 2$

## 8.3.2 TDD

The parameters specified in Table 8.3.2-1 are valid for TDD unless otherwise stated.

**Table 8.3.2-1: Common Test Parameters for User-specific Reference Symbols**

Parameter	Unit	Value
Uplink downlink configuration (Note 1)		1
Special subframe configuration (Note 2)		4
Cyclic prefix		Normal
Cell ID		0
Inter-TTI Distance		1
Number of HARQ processes	Processes	7
Maximum number of HARQ transmission		4
Redundancy version coding sequence		{0,1,2,3} for QPSK and 16QAM {0,0,1,2} for 64QAM, 256QAM and 1024QAM
Number of OFDM symbols for PDCCH	OFDM symbols	2
Precoder update granularity		Frequency domain: 1 PRB for Transmission mode 8, 1 PRG for Transmission modes 9 and 10 Time domain: 1 ms
ACK/NACK feedback mode		Multiplexing
Note 1: as specified in Table 4.2-2 in TS 36.211 [4]		
Note 2: as specified in Table 4.2-1 in TS 36.211 [4]		

### 8.3.2.1 Single-layer Spatial Multiplexing

For single-layer transmission on antenna port 5, the requirements are specified in Table 8.3.2.1-2, with the addition of the parameters in Table 8.3.2.1-1 and the downlink physical channel setup according to Annex C.3.2. The purpose is to verify the demodulation performance using user-specific reference signals with full RB or single RB allocation.

**Table 8.3.2.1-1: Test Parameters for Testing DRS**

Parameter	Unit	Test 1	Test 2	Test 3	Test 4	
Downlink power allocation	$\rho_A$	dB	0	0	0	0
	$\rho_B$	dB	0 (Note 1)	0 (Note 1)	0 (Note 1)	0 (Note 1)
	$\sigma$	dB	0	0	0	0
Cell-specific reference signals		Antenna port 0				
Beamforming model		Annex B.4.1				
$N_{oc}$ at antenna port	dB/15kHz	-98	-98	-98	-98	
Symbols for unused PRBs		OCNG (Note 2)	OCNG (Note 2)	OCNG (Note 2)	OCNG (Note 2)	
PDSCH transmission mode		7	7	7	7	
Note 1: $P_B = 0$ .						
Note 2: These physical resource blocks are assigned to an arbitrary number of virtual UEs with one PDSCH per virtual UE; the data transmitted over the OCNG PDSCHs shall be uncorrelated pseudo random data, which is QPSK modulated.						

Table 8.3.2.1-2: Minimum performance DRS (FRC)

Test number	Bandwidth and MCS	Reference Channel	OCNG Pattern	Propagation Condition	Correlation Matrix and Antenna Configuration	Reference value		UE Category
						Fraction of Maximum Throughput (%)	SNR (dB)	
1	10 MHz QPSK 1/3	R.25 TDD	OP.1 TDD	EPA5	2x2 Low	70	-0.8	$\geq 1$
2	10 MHz 16QAM 1/2	R.26 TDD	OP.1 TDD	EPA5	2x2 Low	70	7.0	$\geq 2$
	5MHz 16QAM 1/2	R.26-1 TDD	OP.1 TDD	EPA5	2x2 Low	70	7.0	1
3	10 MHz 64QAM 3/4	R.27 TDD	OP.1 TDD	EPA5	2x2 Low	70	17.0	$\geq 2$
	10 MHz 64QAM 3/4	R.27-1 TDD	OP.1 TDD	EPA5	2x2 Low	70	17.0	1
4	10 MHz 16QAM 1/2	R.28 TDD	OP.1 TDD	EPA5	2x2 Low	30	1.7	$\geq 1$

For single-layer transmission on antenna ports 7 or 8 upon detection of a PDCCH with DCI format 2B, the requirements are specified in Table 8.3.2.1-4 and 8.3.2.1-5, with the addition of the parameters in Table 8.3.2.1-3 and the downlink physical channel setup according to Annex C.3.2. The purpose of these tests is to verify rank-1 performance on one of the antenna ports 7 or 8 with and without a simultaneous transmission on the other antenna port.

Table 8.3.2.1-3: Test Parameters for Testing CDM-multiplexed DM RS (single layer)

Parameter	Unit	Test 1	Test 2	Test 3	Test 4	Test 5	
Downlink power allocation	$\rho_A$	dB	0	0	0	0	0
	$\rho_B$	dB	0 (Note 1)	0 (Note 1)	0 (Note 1)	0 (Note 1)	0 (Note 1)
	$\sigma$	dB	-3	-3	-3	-3	-3
Cell-specific reference signals		Antenna port 0 and antenna port 1					
Beamforming model		Annex B.4.1					
$N_{oc}$ at antenna port	dBm/15kHz	-98	-98	-98	-98	-98	
Symbols for unused PRBs		OCNG (Note 4)	OCNG (Note 4)	OCNG (Note 4)	OCNG (Note 4)	OCNG (Note 4)	
Simultaneous transmission		No	No	No	Yes (Note 3, 5)	Yes (Note 3, 5)	
PDSCH transmission mode		8	8	8	8	8	
Note 1: $P_B = 1$ . Note 2: The modulation symbols of the signal under test is mapped onto antenna port 7 or 8. Note 3: Modulation symbols of an interference signal is mapped onto the antenna port (7 or 8) not used for the input signal under test. Note 4: These physical resource blocks are assigned to an arbitrary number of virtual UEs with one PDSCH per virtual UE; the data transmitted over the OCNG PDSCHs shall be uncorrelated pseudo random data, which is QPSK modulated. Note 5: The two UEs' scrambling identities $n_{SCID}$ are set to 0 for CDM-multiplexed DM RS with interfering simultaneous transmission test cases.							

**Table 8.3.2.1-4: Minimum performance for CDM-multiplexed DM RS without simultaneous transmission (FRC)**

Test number	Bandwidth and MCS	Reference Channel	OCNG Pattern	Propagation Condition	Correlation Matrix and Antenna Configuration	Reference value		UE Category
						Fraction of Maximum Throughput (%)	SNR (dB)	
1	10 MHz QPSK 1/3	R.31 TDD	OP.1 TDD	EVA5	2x2 Low	70	-1.0	≥1
2	10 MHz 16QAM 1/2	R.32 TDD	OP.1 TDD	EPA5	2x2 Medium	70	7.7	≥2
	5MHz 16QAM 1/2	R.32-1 TDD	OP.1 TDD	EPA5	2x2 Medium	70	7.7	1
3	10 MHz 64QAM 3/4	R.33 TDD	OP.1 TDD	EPA5	2x2 Low	70	17.7	≥2
	10 MHz 64QAM 3/4	R.33-1 TDD	OP.1 TDD	EPA5	2x2 Low	70	17.7	1

**Table 8.3.2.1-5: Minimum performance for CDM-multiplexed DM RS with interfering simultaneous transmission (FRC)**

Test number	Bandwidth and MCS	Reference Channel	OCNG Pattern	Propagation Condition	Correlation Matrix and Antenna Configuration	Reference value		UE Category
						Fraction of Maximum Throughput (%)	SNR (dB)	
4	10 MHz 16QAM 1/2	R.32 TDD (Note 1)	OP.1 TDD	EPA5	2x2 Medium	70	21.9	≥2
5	10 MHz 64QAM 1/2	R.34 TDD (Note 1)	OP.1 TDD	EPA5	2x2 Low	70	22.0	≥2

Note 1: The reference channel applies to both the input signal under test and the interfering signal.

### 8.3.2.1A Single-layer Spatial Multiplexing (with multiple CSI-RS configurations)

For single-layer transmission on antenna ports 7 or 8 upon detection of a PDCCH with DCI format 2C, the requirements are specified in Table 8.3.2.1A-2 and 8.3.2.1A-3, with the addition of the parameters in Table 8.3.2.1A-1 and the downlink physical channel setup according to Annex C.3.2. The purpose of these tests is to verify rank-1 performance on one of the antenna ports 7 or 8 with and without a simultaneous transmission on the other antenna port, and to verify rate matching with multiple CSI reference symbol configurations with non-zero and zero transmission power.

**Table 8.3.2.1A-1: Test Parameters for Testing CDM-multiplexed DM RS (single layer) with multiple CSI-RS configurations**

Parameter	Unit	Test 1, Test 1a	Test 2	Test 3	Test 4, Test 4a	Test 5
Downlink power allocation	$\rho_A$	dB	0	0	0	0
	$\rho_B$	dB	0 (Note 1)	0 (Note 1)	0 (Note 1)	0 (Note 1)
	$\sigma$	dB	-3	-3	-3	-3
Cell-specific reference signals		Antenna ports 0,1				
CSI reference signals		Antenna ports 15,...,22	Antenna ports 15,...,18	Antenna ports 15,...,18	Antenna ports 15,...,22	Antenna ports 15,...,18
Beamforming model		Annex B.4.1	Annex B.4.1	Annex B.4.1	Annex B.4.1	Annex B.4.1
CSI-RS periodicity and subframe offset $T_{\text{CSI-RS}} / \Delta_{\text{CSI-RS}}$	Subframes	5 / 4	5 / 4	5 / 4	5 / 4	5 / 4
CSI reference signal configuration		1	3	3	1	3
csi-RS-ConfigZP-APList		N/A	NA	NA	{0,1}	NA
Zero-power CSI-RS configuration $k_{\text{CSI-RS}} / \text{ZeroPowerCSI-RS}$ bitmap	Subframes / bitmap	4 / 0010000100000000	4 / 0010000000000000	4 / 0010000000000000	0010000100000000 or 0001000100000000 (Note 7)	N/A
$N_{oc}$ at antenna port	dBm/15kHz	-98	-98	-98	-98	-98
Symbols for unused PRBs		OCNG (Note 4)	OCNG (Note 4)	OCNG (Note 4)	OCNG (Note 4)	OCNG (Note 4)
Number of allocated resource blocks (Note 2)	PRB	50	50	100	50	50
Simultaneous transmission		No	Yes (Note 3, 5)	No	No	No
PDSCH transmission mode		9	9	9	9	9
Number of MBSFN subframes	Subframes	2 (Note 6)	NA	NA	2 (Note 7)	NA

Note 1:  $P_B = 1$ .

Note 2: The modulation symbols of the signal under test are mapped onto antenna port 7 or 8.

Note 3: Modulation symbols of an interference signal is mapped onto the antenna port (7 or 8) not used for the input signal under test.

Note 4: These physical resource blocks are assigned to an arbitrary number of virtual UEs with one PDSCH per virtual UE; the data transmitted over the OCNG PDSCHs shall be uncorrelated pseudo random data, which is QPSK modulated.

Note 5: The two UEs' scrambling identities  $n_{\text{SCID}}$  are set to 0 for CDM-multiplexed DM RS with interfering simultaneous transmission test cases.

Note 6: For TDD mode, 2 subframes (#4/9) are allocated as MBSFN subframes.

Note 7: Through DCI signalling, indicating aperiodic ZP-CSI-RS in sub-frames #4 and #9 per frame, the indicated aperiodic ZP-CSI-RS is random selected from RRC-configured AP ZP CSIRS list.

**Table 8.3.2.1A-2: Minimum performance for CDM-multiplexed DM RS without simultaneous transmission (FRC) with multiple CSI-RS configurations**

Test number	Bandwidth and MCS	Reference Channel	OCNG Pattern	Propagation Condition	Correlation Matrix and Antenna Configuration	Reference value		UE Category	UE DL Category
						Fraction of Maximum Throughput (%)	SNR (dB)		
1	10 MHz QPSK 1/3	R.50-1 TDD	OP.1 TDD	EVA5	2x2 Low	70	-0.73	≥1	≥6
1a	10 MHz QPSK 1/3	R.50-2 TDD	OP.1 TDD	EVA5	2x2 Low	70	[-0.6]	≥1	≥6
3	20MHz 256QAM	R. 66 TDD	OP.1 TDD	EPA5	2x2 Low	70	24.3	11-12	≥11
4	10 MHz QPSK 1/3	R.50-1 TDD	OP.1 TDD	EVA5	2x2 Low	70	[-0.73]	≥1	≥6
4a	10 MHz QPSK 1/3	R.50-2 TDD	OP.1 TDD	EVA5	2x2 Low	[70]	TBD	≥1	≥6
5	10MHz 1024QAM	R.101 TDD	OP.1 TDD	EPA5	4x2 Low	70	29.0	TBD	20, ≥ 22

Note 1: For UE that does not support aperiodic ZP-CSI-RS, test 1a will be run and test 1 will be skipped if the UE indicates support of *pdsch-CollisionHandling-r13*. Otherwise, test 1 will be run and test 1a will be skipped. For UE that does not support aperiodic ZP-CSI-RS, test 4 and test 4a will be skipped.

Note 2: For UE that supports AP ZP CSIRS, test 4a will be run and test 4 will be skipped if the UE indicates support of *pdsch-CollisionHandling-r13*. Otherwise, test 4 will be run and test 4a will be skipped. For UE that supports AP ZP CSIRS, test 1 and test 1a will be skipped.

**Table 8.3.2.1A-3: Minimum performance for CDM-multiplexed DM RS with interfering simultaneous transmission (FRC) with multiple CSI-RS configurations**

Test number	Bandwidth and MCS	Reference Channel	OCNG Pattern	Propagation Condition	Correlation Matrix and Antenna Configuration	Reference value		UE Category
						Fraction of Maximum Throughput (%)	SNR (dB)	
2	10 MHz 64QAM 1/2	R.44 TDD	OP.1 TDD	EPA5	2x2 Low	70	22.1	≥2

Note 1: The reference channel applies to both the input signal under test and the interfering signal.

### 8.3.2.1B Enhanced Performance Requirement Type A – Single-layer Spatial Multiplexing with TM9 interference model

The requirements are specified in Table 8.3.2.1B-2, with the addition of the parameters in Table 8.3.2.1B-1 and the downlink physical channel setup according to Annex C.3.2. The purpose of these tests is to verify closed-loop rank one performance on one of the antenna ports 7 or 8 without a simultaneous transmission on the other antenna port in the serving cell when the PDSCH transmission in the serving cell is interfered by PDSCH of one dominant interfering cell applying transmission mode 9 interference model defined in clause B.5.4. In 8.3.2.1B-1, Cell 1 is the serving cell, and Cell 2 is the interfering cell. The downlink physical channel setup is according to Annex C.3.2 for each of Cell 1 and Cell 2, respectively.

**Table 8.3.2.1B-1: Test Parameters for Testing CDM-multiplexed DM RS (single layer) with TM9 interference model**

parameter		Unit	Cell 1	Cell 2
Downlink power allocation	$\rho_A$	dB	0	0
	$\rho_B$	dB	0 (Note 1)	0
	$\sigma$	dB	-3	-3
Cell-specific reference signals			Antenna ports 0,1	Antenna ports 0,1
CSI reference signals			Antenna ports 15,...,18	N/A
CSI-RS periodicity and subframe offset $T_{\text{CSI-RS}} / \Delta_{\text{CSI-RS}}$		Subframes	5 / 4	N/A
CSI reference signal configuration			0	N/A
$N_{\text{oc}}$ at antenna port $z$		dBm/15kHz	-98	N/A
DIP (Note 2)		dB	N/A	-1.73
BW <sub>Channel</sub>		MHz	10	10
Cyclic Prefix			Normal	Normal
Cell Id			0	126
Number of control OFDM symbols			2	2
PDSCH transmission mode			9	N/A
Beamforming model			As specified in clause B.4.3 (Note 4, 5)	N/A
Interference model			N/A	As specified in clause B.5.4
Probability of occurrence of transmission rank in interfering cells	Rank 1		N/A	70
	Rank 2		N/A	30
Precoder update granularity		PRB	50	6
PMI delay (Note 5)		ms	10 or 11	N/A
Reporting interval		ms	5	N/A
Reporting mode			PUCCH 1-1	N/A
CodeBookSubsetRestriction bitmap			0000000000000000 0000000000000000 0000000000000000 1111111111111111	N/A
Symbols for unused PRBs			OCNG (Note 6)	N/A
Simultaneous transmission			No simultaneous transmission on the other antenna port in (7 or 8) not used for the input signal under test	N/A
Physical channel for CQI reporting			PUSCH(Note 8)	N/A
cqi-pmi-ConfigurationIndex			4	N/A



Note 1:	$P_B = 1$
Note 2:	The respective received power spectral density of each interfering cell relative to $N_{oc}$ is defined by its associated DIP value as specified in clause B.5.1.
Note 3:	The modulation symbols of the signal under test in Cell 1 are mapped onto antenna port 7 or 8.
Note 4:	The precoder in clause B.4.3 follows UE recommended PMI.
Note 5:	If the UE reports in an available uplink reporting instance at subframe SF#n based on PMI estimation at a downlink SF not later than SF#(n-4), this reported PMI cannot be applied at the eNB downlink before SF#(n+4).
Note 6:	These physical resource blocks are assigned to an arbitrary number of virtual UEs with one PDSCH per virtual UE; the data transmitted over the OCNB PDSCHs shall be uncorrelated pseudo random data, which is QPSK modulated.
Note 7:	All cells are time-synchronous.
Note 8:	To avoid collisions between CQI reports and HARQ-ACK it is necessary to report both on PUSCH instead of PUCCH. PDCCH DCI format 0 shall be transmitted in downlink SF#4 and #9 to allow periodic CQI to multiplex with the HARQ-ACK on PUSCH in uplink subframe SF#8 and #3.

**Table 8.3.2.1B-2: Enhanced Performance Requirement Type A, CDM-multiplexed DM RS with TM9 interference model**

Test Number	Reference Channel	OCNG Pattern		Propagation Conditions		Correlation Matrix and Antenna Configuration (Note 3)	Reference Value		UE Category
		Cell 1	Cell 2	Cell 1	Cell 2		Fraction of Maximum Throughput (%)	SINR (dB) (Note 2)	
1	R.48 TDD	OP.1 TDD	N/A	EVA5	EVA5	4x2 Low	70	-1.0	≥1
Note 1: The propagation conditions for Cell 1 and Cell 2 are statistically independent.									
Note 2: SINR corresponds to $E_s/N_{oc}$ of Cell 1 as defined in clause 8.1.1.									
Note 3: Correlation matrix and antenna configuration parameters apply for each of Cell 1 and Cell 2.									

### 8.3.2.1C Single-layer Spatial Multiplexing (demodulation subframe overlaps with aggressor cell ABS and CRS assistance information are configured)

The requirements are specified in Table 8.3.2.1C-2, with the addition of parameters in Table 8.3.2.1C-1. The purpose is to verify the performance of the antenna ports 7 or 8 without a simultaneous transmission on the other antenna port in the serving cell if the PDSCH transmission in the serving cell takes place in subframes that overlap with ABS [9] of the aggressor cell with CRS assistance information. In Table 8.3.2.1C-1, Cell 1 is the serving cell, and Cell 2 and Cell 3 are the aggressor cells. The downlink physical channel setup for Cell 1 is according to Annex C.3.2 and for Cell 2 and Cell 3 is according to Annex C.3.3, respectively. The CRS assistance information [7] includes Cell 2 and Cell 3.

**Table 8.3.2.1C-1: Test parameters of TM9-Single-Layer (2 CSI-RS ports) – Non-MBSFN ABS**

Parameter	Unit	Cell 1	Cell 2	Cell 3	
Uplink downlink Configuration		1	1	1	
Special subframe configuration		4	4	4	
Downlink power allocation	$\rho_A$	dB	0	-3	-3
	$\rho_B$	dB	0 (Note 1)	-3 (Note 1)	-3 (Note 1)
	$\sigma$	dB	-3	N/A	N/A
$N_{oc}$ at antenna port	$N_{oc1}$	dBm/15kHz	-98 (Note 2)	N/A	N/A
	$N_{oc2}$	dBm/15kHz	-98 (Note 3)	N/A	N/A
	$N_{oc3}$	dBm/15kHz	-93 (Note 4)	N/A	N/A
$\bar{E}_s/N_{oc2}$	dB	Reference Value in Table 8.3.2.1C-2	12	10	
$BW_{Channel}$	MHz	10	10	10	
Subframe Configuration		Non-MBSFN	Non-MBSFN	Non-MBSFN	
Time Offset between Cells	$\mu s$	N/A	3	-1	
Frequency shift between Cells	Hz	N/A	300	-100	
Cell Id		0	1	126	
Cell-specific reference signals		Antenna ports 0,1			
CSI reference signals		Antenna ports 15,16	N/A	N/A	
CSI-RS periodicity and subframe offset $T_{CSI-RS} / \Delta_{CSI-RS}$	Subframes	5 / 4	N/A	N/A	
CSI reference signal configuration		8	N/A	N/A	
Zero-power CSI-RS configuration $I_{CSI-RS} / ZeroPowerCSI-RS$ bitmap	Subframes / bitmap	4 / 00100000000000	N/A	N/A	
ABS pattern (Note 5)		N/A	0000000001 0000000001	0000000001 0000000001	
RLM/RRM Measurement Subframe Pattern (Note 6)		0000000001 0000000001	N/A	N/A	
CSI Subframe Sets (Note7)	$C_{CSI,0}$	0000000001 0000000001	N/A	N/A	
	$C_{CSI,1}$	1100111000 1100111000	N/A	N/A	
Number of control OFDM symbols		2	Note 8	Note 8	
PDSCH transmission mode		TM9-1layer	Note 9	Note 9	
Precoding granularity		Frequency domain: 1 PRG Time domain: 1 ms	N/A	N/A	
Beamforming model		Annex B.4.1	N/A	N/A	
Cyclic prefix		Normal	Normal	Normal	

- Note 1:  $P_B = 1$ .
- Note 2: This noise is applied in OFDM symbols #1, #2, #3, #5, #6, #8, #9, #10, #12, #13 of a subframe overlapping with the aggressor ABS.
- Note 3: This noise is applied in OFDM symbols #0, #4, #7, #11 of a subframe overlapping with the aggressor ABS.
- Note 4: This noise is applied in all OFDM symbols of a subframe overlapping with aggressor non-ABS.
- Note 5: ABS pattern as defined in [9]. PDSCH other than SIB1/paging and its associated PDCCH/PCFICH are transmitted in the serving cell subframe when the subframe is overlapped with the ABS subframe of aggressor cell and the subframe is available in the definition of the reference channel.
- Note 6: Time-domain measurement resource restriction pattern for PCell measurements as defined in [7].
- Note 7: As configured according to the time-domain measurement resource restriction pattern for CSI measurements defined in [7].
- Note 8: The number of control OFDM symbols is not available for ABS and is 2 for the subframe indicated by "0" of ABS pattern.
- Note 9: Downlink physical channel setup in Cell 2 and Cell 3 in accordance with Annex C.3.3 applying OCNB pattern as defined in Annex A.5.
- Note 10: If the UE reports in an available uplink reporting instance at subframe SF#n based on PMI estimation at a downlink SF not later than SF#(n-4), this reported PMI cannot be applied at the eNB downlink before SF#(n+4).
- Note 11: For Uplink - downlink configuration 1 the reporting interval will alternate between 1ms and 4ms.
- Note 12: The number of the CRS ports in Cell 1, Cell 2 and Cell 3 is the same.
- Note 13: SIB-1 will not be transmitted in Cell 2 and Cell 3 in this test.
- Note 14: The modulation symbols of the signal under test are mapped onto antenna port 7 or 8.

Table 8.3.2.1C-2: Minimum Performance of TM9-Single-Layer (2 CSI-RS ports) – Non-MBSFN ABS

Test Number	Reference Channel	OCNB Pattern			Propagation Conditions (Note1)			Correlation Matrix and Antenna Configuration (Note 2)	Reference Value		UE Category
		Cell 1	Cell 2	Cell 3	Cell 1	Cell 2	Cell 3		Fraction of Maximum Throughput (%)	SNR (dB) (Note 3)	
1	R.51 TDD	OP.1 TDD	OP.1 TDD	OP.1 TDD	EVA5			2x2 Low	70	8.5	≥2
Note 1:	The propagation conditions for Cell 1, Cell 2 and Cell 3 are statistically independent.										
Note 2:	The correlation matrix and antenna configuration apply for Cell 1, Cell 2 and Cell 3.										
Note 3:	SNR corresponds to $\hat{E}_s/N_{oc2}$ of cell 1.										

### 8.3.2.1D Enhanced Performance Requirement Type B – Single-layer Spatial Multiplexing with TM9 interference

The requirements are specified in Table 8.3.2.1D-2, with the addition of the parameters in Table 8.3.2.1D-1 and the downlink physical channel setup according to Annex C.3.2. The purpose of these tests is to verify closed loop rank one performance on one of the antenna ports 7 or 8 without a simultaneous transmission on the other antenna port in the serving cell when the PDSCH transmission in the serving cell is interfered by PDSCH of two interfering cells applying transmission mode 9 interference model defined in clause B.6.4. In 8.3.2.1D-1, Cell 1 is the serving cell, and Cell 2, 3 are interfering cells. The downlink physical channel setup is according to Annex C.3.2 for each of Cell 1, Cell 2 and Cell 3, respectively.

**Table 8.3.2.1D-1: Test Parameters for Testing CDM-multiplexed DM RS (Single-layer) with TM9 interference model**

Parameter		Unit	Cell 1	Cell 2	Cell 3
Uplink downlink Configuration			1	1	1
Special subframe configuration			4	4	4
Downlink power allocation	$\rho_A$	dB	0	0	0
	$\rho_B$	dB	0 (Note 1)	0	0
	$\sigma$	dB	-3	-3	-3
Cell-specific reference signals			Antenna ports 0,1	Antenna ports 0,1	Antenna ports 0,1
$N_{oc}$ at antenna port		dBm/15kHz	-98		
$\bar{E}_s/N_{oc}$		dB	N/A	13.91	3.34
BW <sub>Channel</sub>		MHz	10	10	10
Cyclic Prefix			Normal	Normal	Normal
Cell Id			0	1	6
Number of control OFDM symbols in normal subframes			3	3	3
CFI indicated in PCFICH in normal subframes			3	3	3
Number of control OFDM symbols in special subframes			2	2	2
CFI indicated in PCFICH in special subframes			2	2	2
PDSCH transmission mode			9	9	9
Interference model			N/A	As specified in clause B.6.4	As specified in clause B.6.4
Precoding			Random wideband precoding per TTI	As specified in clause B.6.4	As specified in clause B.6.4
CSI reference signals			Antenna ports 15, 16, 17, 18	Antenna ports 15, 16	Antenna ports 15, 16
CSI-RS periodicity and subframe offset $T_{CSI-RS} / \Delta_{CSI-RS}$		Subframes	10 / 4	10 / 4	10 / 4
CSI reference signal configuration			5	6	7
Zero-power CSI-RS configuration $I_{CSI-RS} / \text{ZeroPowerCSI-RS}$ bitmap		Subframes / bitmap	9 / 1000000000 00000	9 / 0100000000 0000	9 / 0010000000 00000
Time offset to cell 1		us	N/A	2	3
Frequency offset to cell 1		Hz	N/A	200	300
MBSFN			Not configured	Not configured	Not configured
NeighCellsInfo-r12 (Note 4)	p-aList-r12		N/A	{dB-6, dB-3, dB0}	{dB-6, dB-3, dB0}
	transmissionModeList-r12		N/A	{2,3,4,8,9}	{2,3,4,8,9}
Note 1: $P_B = 1$					
Note 2: Cell 1 is the serving cell. Cell 2, 3 are the interfering cells.					
Note 3: CSI-RS configurations are according to [4] subclause 6.10.5.2.					
Note 4: NeighCellsInfo-r12 is described in subclause 6.3.2 of [7].					

**Table 8.3.2.1D-2: Minimum Performance for Enhanced Performance Requirement Type B, CDM-multiplexed DM RS with TM9 interference model**

Test Number	Reference Channel	OCNG Pattern			Propagation Conditions			Correlation Matrix and Antenna Configuration			Reference Value		UE Category
		Cell 1	Cell 2	Cell 3	Cell 1	Cell 2	Cell 3	Cell 1	Cell 2	Cell 3	Fraction of Maximum Throughput (%)	SNR (dB) (Note 2)	
1	R.69 TDD	OP. 1 TD D	N/A	N/A	EP A5	EP A5	EP A5	4x2 Low	2x2 Low	2x2 Low	85	18.0	≥1
Note 1: The propagation conditions for Cell 1, Cell 2 and Cell 3 are statistically independent. Note 2: SNR corresponds to $E_s/N_{oc}$ of Cell 1 as defined in clause 8.1.1.													

### 8.3.2.1E Enhanced Performance Requirement Type B – Single-layer Spatial Multiplexing with CRS interference model

The requirements are specified in Table 8.3.2.1E-2, with the addition of the parameters in Table 8.3.2.1E-1 and the downlink physical channel setup according to Annex C.3.2. The purpose of these tests is to verify closed loop rank one performance on one of the antenna ports 7 or 8 without a simultaneous transmission on the other antenna port in the serving cell when the PDSCH transmission in the serving cell is interfered by the CRS of the interfering cell, applying the CRS interference model defined in clause B.6.5. In 8.3.2.1E-1, Cell 1 is the serving cell, and Cell 2, 3 are interfering cells. The downlink physical channel setup is according to Annex C.3.2 for each of Cell 1, Cell 2 and Cell 3, respectively.

**Table 8.3.2.1E-1: Test Parameters for Testing CDM-multiplexed DM RS (Single-layer) with CRS interference model**

Parameter		Unit	Cell 1	Cell 2	Cell 3
Uplink downlink Configuration			1	1	1
Special subframe configuration			4	4	4
Downlink power allocation	$\rho_A$	dB	0	0	0
	$\rho_B$	dB	0 (Note 1)	0	0
	$\sigma$	dB	-3	-3	-3
Cell-specific reference signals			Antenna ports 0,1	Antenna ports 0,1	Antenna ports 0,1
$N_{oc}$ at antenna port		dBm/15kHz	-98		
$\bar{E}_s/N_{oc}$		dB	N/A	13.91	3.34
BW <sub>Channel</sub>		MHz	10	10	10
Cyclic Prefix			Normal	Normal	Normal
Cell Id			0	1	6
Number of control OFDM symbols in normal subframes			3	3	3
CFI indicated in PCFICH in normal subframes			3	3	3
Number of control OFDM symbols in special subframes			2	2	2
CFI indicated in PCFICH in special subframes			2	2	2
PDSCH transmission mode			8	N/A	N/A
Interference model			N/A	As specified in clause B.6.5	As specified in clause B.6.5
Precoding			Random wideband precoding per TTI	N/A	N/A
Time offset to cell 1		us	N/A	2	3
Frequency offset to cell 1		Hz	N/A	200	300
MBSFN			Not configured	Not configured	Not configured
NeighCellsInfo-r12 (Note 3)	p-aList-r12		N/A	{dB-6, dB-3, dB0}	{dB-6, dB-3, dB0}
	transmissionModeList-r12		N/A	{2,3,4,8,9}	{2,3,4,8,9}
Note 1: $P_B = 1$					
Note 2: Cell 1 is the serving cell. Cell 2, 3 are the interfering cells.					
Note 3: NeighCellsInfo-r12 is described in subclause 6.3.2 of [7].					

**Table 8.3.2.1E-2: Minimum Performance for Enhanced Performance Requirement Type B, CDM-multiplexed DM RS with CRS interference model**

Test Number	Reference Channel	OCNG Pattern			Propagation Conditions			Correlation Matrix and Antenna Configuration (Note 3)	Reference Value		UE Category
		Cell 1	Cell 2	Cell 3	Cell 1	Cell 2	Cell 3		Fraction of Maximum Throughput (%)	SNR (dB) (Note 2)	
1	R.71 TDD	OP. 1 TD D	N/A	N/A	EP A5	EP A5	EP A5	2x2 Low	85	14.0	≥2
Note 1: The propagation conditions for Cell 1, Cell 2 and Cell 3 are statistically independent.											
Note 2: SNR corresponds to $\bar{E}_s/N_{oc}$ of Cell 1 as defined in clause 8.1.1.											
Note 3: Correlation matrix and antenna configuration parameters apply for each of Cell 1, Cell 2 and Cell 3.											

### 8.3.2.1F Enhanced Performance Requirement Type B – Single-layer Spatial Multiplexing with TM3 interference

The requirements are specified in Table 8.3.2.1F-2, with the addition of the parameters in Table 8.3.2.1F-1 and the downlink physical channel setup according to Annex C.3.2. The purpose of these tests is to verify closed loop rank one performance on one of the antenna ports 7 or 8 without a simultaneous transmission on the other antenna port in the serving cell when the PDSCH transmission in the serving cell is interfered by PDSCH of two interfering cells applying transmission mode 3 interference model defined in clause B.6.2. In 8.3.2.1F-1, Cell 1 is the serving cell, and Cell 2, 3 are interfering cells. The downlink physical channel setup is according to Annex C.3.2 for each of Cell 1, Cell 2 and Cell 3, respectively.

**Table 8.3.2.1F-1: Test Parameters for Testing CDM-multiplexed DM RS (Single-layer) with TM3 interference model**

Parameter		Unit	Cell 1	Cell 2	Cell 3
Uplink downlink Configuration			1	1	1
Special subframe configuration			4	4	4
Downlink power allocation	$\rho_A$	dB	0	-3	-3
	$\rho_B$	dB	0 (Note 1)	-3	-3
	$\sigma$	dB	-3	0	0
Cell-specific reference signals			Antenna ports 0,1	Antenna ports 0,1	Antenna ports 0,1
$N_{oc}$ at antenna port		dBm/15kHz	-98		
$\bar{E}_s/N_{oc}$		dB	N/A	3.28	0.74
BW <sub>channel</sub>		MHz	10	10	10
Cyclic Prefix			Normal	Normal	Normal
Cell Id			0	1	6
Number of control OFDM symbols in normal subframes			3	3	3
CFI indicated in PCFICH in normal subframes			3	Random from set {1,2,3}	Random from set {1,2,3}
Number of control OFDM symbols in special subframes			2	2	2
CFI indicated in PCFICH in special subframes			2	Random from set {1,2}	Random from set {1,2}
PDSCH transmission mode			8	3	3
Interference model			N/A	As specified in clause B.6.2	As specified in clause B.6.2
Precoding			Random wideband precoding per TTI	As specified in clause B.6.2	As specified in clause B.6.2
Time offset to cell 1		us	N/A	2	3
Frequency offset to cell 1		Hz	N/A	200	300
MBSFN			Not configured	Not configured	Not configured
NeighCellsInfo-r12 (Note 4)	p-aList-r12		N/A	{dB-6, dB-3, dB0}	{dB-6, dB-3, dB0}
	transmissionModeList-r12		N/A	{2,3,4,8,9}	{2,3,4,8,9}
Note 1: $P_B = 1$ Note 2: Cell 1 is the serving cell. Cell 2, 3 are the interfering cells. Note 3: CSI-RS configurations are according to [4] subclause 6.10.5.2. Note 4: NeighCellsInfo-r12 is described in subclause 6.3.2 of [7].					



**Table 8.3.2.1F-2: Minimum Performance for Enhanced Performance Requirement Type B, CDM-multiplexed DM RS with TM3 interference model**

Test Number	Reference Channel	OCNG Pattern			Propagation Conditions			Correlation Matrix and Antenna Configuration (Note 3)	Reference Value		UE Category
		Cell 1	Cell 2	Cell 3	Cell 1	Cell 2	Cell 3		Fraction of Maximum Throughput (%)	SNR (dB) (Note 2)	
1	R.70 TDD	OP. 1 TD D	N/A	N/A	EP A5	EP A5	EP A5	2x2 Low	85	11.3	≥1
Note 1: The propagation conditions for Cell 1, Cell 2 and Cell 3 are statistically independent. Note 2: SNR corresponds to $E_s/N_{oc}$ of Cell 1 as defined in clause 8.1.1. Note 3: Correlation matrix and antenna configuration parameters apply for each of Cell 1, Cell 2 and Cell 3.											

### 8.3.2.1G Enhanced Performance Requirement Type B – Single-layer Spatial Multiplexing with TM10 serving cell configuration and TM9 interference model

The requirements are specified in Table 8.3.2.1G-2, with the addition of the parameters in Table 8.3.2.1G-1 and the downlink physical channel setup according to Annex C.3.2. The purpose of these tests is to verify closed loop rank one performance on one of the antenna ports 7 or 8 without a simultaneous transmission on the other antenna port in the serving cell when the PDSCH transmission configured with TM10 in the serving cell is interfered by PDSCH of one dominant interfering cell applying transmission mode 9 interference model defined in clause B.6.3. The NAICS network assistance is provided when the serving cell TM10 is configured with QCL-type A and PCID based DM-RS scrambling. The neighbouring cell has transmission mode TM9 and NeighCellsInfo-r12 for interfering cell indicates presence of TM9. In 8.3.2.1G-1, Cell 1 is the serving cell, and Cell 2, 3 are interfering cells. The downlink physical channel setup is according to Annex C.3.2 for each of Cell 1, Cell 2 and Cell 3, respectively.

**Table 8.3.2.1G-1: Test Parameters for Testing CDM-multiplexed DM RS (single layer) Multiplexing with TM10 serving cell configuration and TM9 interference model**

Parameter		Unit	Cell 1	Cell 2	Cell 3
Uplink downlink Configuration			1	1	1
Special subframe configuration			4	4	4
Downlink power allocation	$\rho_A$	dB	0	0	0
	$\rho_B$	dB	0 (Note 1)	0	0
	$\sigma$	dB	-3	-3	-3
Cell-specific reference signals			Antenna ports 0,1	Antenna ports 0,1	Antenna ports 0,1
$N_{oc}$ at antenna port		dBm/15kHz	-98		
$E_s/N_{oc}$		dB	N/A	13.91	3.34
BW <sub>Channel</sub>		MHz	10	10	10
Cyclic Prefix			Normal	Normal	Normal
Cell Id			0	1	6
Number of control OFDM symbols in normal subframes			3	3	3
CFI indicated in PCFICH in normal subframes			3	3	3
Number of control OFDM symbols in special subframes			2	2	2
CFI indicated in PCFICH in special subframes			2	2	2
PDSCH transmission mode			10	9	9
Interference model			N/A	As specified in clause B.6.4	As specified in clause B.6.4
Precoding			Random wideband precoding per TTI	As specified in clause B.6.4	As specified in clause B.6.4
CSI reference signals			Antenna ports 15, 16, 17, 18	Antenna ports 15, 16	Antenna ports 15, 16
CSI-RS periodicity and subframe offset $T_{CSI-RS} / \Delta_{CSI-RS}$		Subframes	10 / 4	10 / 4	10 / 4
CSI reference signal configuration			5	6	7
Zero-power CSI-RS configuration $l_{CSI-RS} / ZeroPowerCSI-RS$ bitmap		Subframes / bitmap	9 / 10000000000 00000	9 / 01000000000 0000	9 / 00100000000 00000
Time offset to cell 1		us	N/A	2	3
Frequency offset to cell 1		Hz	N/A	200	300
MBSFN			Not configured	Not configured	Not configured
NeighCellsInfo-r12 (Note 4)	p-aList-r12		N/A	{dB-6, dB-3, dB0}	{dB-6, dB-3, dB0}
	transmissionModeList-r12		N/A	{2,3,4,8,9}	{2,3,4,8,9}
Note 1: $P_B = 1$					
Note 2: Cell 1 is the serving cell. Cell 2, 3 are the interfering cells.					
Note 3: CSI-RS configurations are according to [4] subclause 6.10.5.2.					
Note 4: NeighCellsInfo-r12 is described in subclause 6.3.2 of [7].					

**Table 8.3.2.1G-2: Minimum Performance for Enhanced Performance Requirement Type B, CDM-multiplexed DM RS Multiplexing with TM10 serving cell configuration and TM9 interference model**

Test Number	Reference Channel	OCNG Pattern			Propagation Conditions			Correlation Matrix and Antenna Configuration			Reference Value		UE Category
		Cell 1	Cell 2	Cell 3	Cell 1	Cell 2	Cell 3	Cell 1	Cell 2	Cell 3	Fraction of Maximum Throughput (%)	SNR (dB) (Note 2)	
1	R.69 TDD	OP. 1 TDD	N/A	N/A	EP A5	EP A5	EP A5	4x 2 Low	2x 2 Low	2x 2 Low	85	18.0	≥1
Note 1: The propagation conditions for Cell 1, Cell 2 and Cell 3 are statistically independent. Note 2: SINR corresponds to $E_s/N_{oc}$ of Cell 1 as defined in clause 8.1.1.													

### 8.3.2.1H Single-layer Spatial Multiplexing (CRS assistance information is configured)

The requirements are specified in Table 8.3.2.1H-2, with the addition of parameters in Table 8.3.2.1H-1. The purpose is to verify the performance of the antenna ports 7 or 8 without a simultaneous transmission on the other antenna port in the serving cell with CRS assistance information. In Table 8.3.2.1H-1, Cell 1 is the serving cell, and Cell 2 and Cell 3 are the aggressor cells. The downlink physical channel setup for Cell 1, Cell 2 and Cell 3 is according to Annex C.3.2. The CRS assistance information [7] includes Cell 2 and Cell 3.

Table 8.3.2.1H-1: Test parameters of TM9-Single-Layer (2 CSI-RS ports)

Parameter	Unit	Cell 1	Cell 2	Cell 3	
Uplink downlink Configuration		1	1	1	
Special subframe configuration		4	4	4	
Downlink power allocation	$\rho_A$	dB	0	0	0
	$\rho_B$	dB	0 (Note 1)	0 (Note 1)	0 (Note 1)
	$\sigma$	dB	-3	-3	-3
$N_{oc}$ at antenna port	dBm/15kHz	-98	N/A	N/A	
$\bar{E}_s/N_{oc}$	dB	Reference Value in Table 8.3.2.1H-2	10.45	4.6	
$BW_{Channel}$	MHz	10	10	10	
Subframe Configuration		Non-MBSFN	Non-MBSFN	Non-MBSFN	
Time Offset to Cell 1	$\mu s$	N/A	3	-1	
Frequency shift to Cell 1	Hz	N/A	300	-100	
Cell Id		0	1	126	
Cell-specific reference signals		Antenna ports 0,1			
CSI reference signals		Antenna ports 15,16	N/A	N/A	
CSI-RS periodicity and subframe offset $T_{CSI-RS} / \Delta_{CSI-RS}$	Subframes	5 / 4	N/A	N/A	
CSI reference signal configuration		8	N/A	N/A	
Zero-power CSI-RS configuration $I_{CSI-RS} / \text{ZeroPowerCSI-RS}$ bitmap	Subframes / bitmap	4 / 001000000000000	N/A	N/A	
Number of control OFDM symbols		2	2	2	
PD SCH transmission mode		TM9-1layer	N/A	N/A	
Interference model		N/A	As specified in clause B.5.4	As specified in clause B.5.4	
Probability of occurrence of transmission in interference cells	%	N/A	20	20	
Probability of occurrence of transmission rank in interfering cells	Rank 1	%	N/A	80	80
	Rank 2	%	N/A	20	20
Precoding granularity		Frequency domain: 1 PRG Time domain: 1 ms	N/A	N/A	
Beamforming model		Annex B.4.1	N/A	N/A	
Cyclic prefix		Normal	Normal	Normal	
<p>Note 1: <math>P_B = 1</math>.</p> <p>Note 2: If the UE reports in an available uplink reporting instance at subframe SF#n based on PMI estimation at a downlink SF not later than SF#(n-4), this reported PMI cannot be applied at the eNB downlink before SF#(n+4).</p> <p>Note 3: For Uplink - downlink configuration 1 the reporting interval will alternate between 1ms and 4ms.</p> <p>Note 4: The number of the CRS ports in Cell 1, Cell 2 and Cell 3 is the same.</p> <p>Note 5: SIB-1 will not be transmitted in Cell 2 and Cell 3 in this test.</p> <p>Note 6: The modulation symbols of the signal under test are mapped onto antenna port 7 or 8.</p>					

Table 8.3.2.1H-2: Minimum Performance of TM9-Single-Layer (2 CSI-RS ports)

Test Number	Reference Channel	OCNG Pattern			Propagation Conditions (Note1)			Correlation Matrix and Antenna Configuration (Note 2)	Reference Value		UE Category
		Cell 1	Cell 2	Cell 3	Cell 1	Cell 2	Cell 3		Fraction of Maximum Throughput (%)	SNR (dB) (Note 3)	
1	R.51-1 TDD	OP.1 TDD	N/A	N/A	EVA5			2x2 Low	70	11.9	≥2
Note 1: The propagation conditions for Cell 1, Cell 2 and Cell 3 are statistically independent. Note 2: The correlation matrix and antenna configuration apply for Cell 1, Cell 2 and Cell 3. Note 3: SNR corresponds to $\hat{E}_s/N_{0c}$ of cell 1.											

### 8.3.2.11 Single-layer Spatial Multiplexing (With Enhanced DMRS table configured)

For single-layer transmission on antenna port 7, 8, 11 or 13 upon detection of a PDCCH with DCI format 2C, the requirement is specified in Table 8.3.2.1H-2, with the addition of the parameters in Table 8.3.2.1H-1 and the downlink physical channel setup according to Annex C.3.2. The purpose of the test is to verify rank-1 performance on antenna port 11 with a simultaneous transmission on the antenna port 7, 8 or 13 with DMRS enhancement table and 4 orthogonal DMRS ports (dmrs-Enhancements-r13 UE-EUTRA-Capability [7]).

**Table 8.3.2.1I-1: Test Parameters for Testing CDM-multiplexed DM RS (single layer) with interfering simultaneous transmission (FRC) with multiple CSI-RS configurations with Enhanced DMRS table**

parameter	Unit	Test 1	
Downlink power allocation	$\rho_A$	dB	0
	$\rho_B$	dB	0 (Note 1)
	$\sigma$	dB	-3
Beamforming model		Annex B.4.1A	
Cell-specific reference signals		Antenna ports 0,1	
CSI reference signals		Antenna ports 15,...,18	
CSI-RS periodicity and subframe offset $T_{\text{CSI-RS}} / \Delta_{\text{CSI-RS}}$	Subframes	5 / 4	
CSI reference signal configuration		3	
Zero-power CSI-RS configuration $I_{\text{CSI-RS}} / \text{ZeroPowerCSI-RS bitmap}$	Subframes / bitmap	4 / 0010000000000000	
$N_{oc}$ at antenna port	dBm/15kHz	-98	
Symbols for unused PRBs		OCNG (Note 4)	
Number of allocated resource blocks (Note 2)	PRB	50	
Simultaneous transmission		Yes (Note 3, 5)	
dmsr-Enhancements-r13		Enable	
PDSCH transmission mode		9	
Note 1: $P_B = 1$ . Note 2: The modulation symbols of the signal under test are mapped onto antenna port 11. Note 3: Modulation symbols of an interference signal are random mapped onto one antenna port among antenna port 7, 8 and 13. The update granularity for randomized mapping antenna port is 1 PRG in frequency domain and 1ms in time domain. Note 4: These physical resource blocks are assigned to an arbitrary number of virtual UEs with one PDSCH per virtual UE; the data transmitted over the OCNG PDSCHs shall be uncorrelated pseudo random data, which is QPSK modulated. Note 5: The two UEs' scrambling identities $n_{\text{SCID}}$ are set to 0 with OCC =4.			

**Table 8.3.2.1I-2: Minimum performance for CDM-multiplexed DM RS with interfering simultaneous transmission (FRC) with multiple CSI-RS configurations with Enhanced DMRS table**

Test number	Bandwidth and MCS	Reference Channel	OCNG Pattern	Propagation Condition	Correlation Matrix and Antenna Configuration	Reference value		UE Category
						Fraction of Maximum Throughput (%)	SNR (dB)	
1	10 MHz 64QAM 1/2	R.44 TDD	OP.1 TDD	EPA5	2x2 Low	70	22.1	≥2

Note 1: The reference channel applies to both the input signal under test and the interfering signal.

### 8.3.2.1J Single-layer Spatial Multiplexing (with assistance information for simultaneous transmission interfering PDSCH)

For single-layer transmission on a DMRS antenna port upon detection of a PDCCH with DCI format 2C, the requirements are specified in Table 8.3.2.1J-1, with the addition of the parameters in Table 8.3.2.1J-2 and the downlink physical channel setup according to Annex C.3.2. The purpose of these tests is to verify rank-1 performance on one

DMRS antenna port with a simultaneous transmission on one of the other DMRS antenna port with or without DMRS enhancement table and 4 orthogonal DMRS ports (dmrs-Enhancements-r13 UE-EUTRA-Capability [7]).

**Table 8.3.2.1J-1: Test Parameters for Minimum Performance Requirement - Single-layer Spatial Multiplexing with assistance information for simultaneous transmission interfering PDSCH (FRC)**

parameter		Unit	Test 1	Test 2	Test 3
Downlink power allocation	$\rho_A$	dB	0		
	$\rho_B$	dB	0 (Note 1)		
	$\sigma$	dB	-3		
Beamforming model			Annex B.4.1		
Cell-specific reference signals			Antenna ports 0,1		
CSI reference signals			Antenna ports 15,...,18		
CSI-RS periodicity and subframe offset $T_{\text{CSI-RS}} / \Delta_{\text{CSI-RS}}$		Subframes	5 / 4		
CSI reference signal configuration			3		
Zero-power CSI-RS configuration $l_{\text{CSI-RS}} /$ ZeroPowerCSI-RS bitmap		Subframes / bitmap	4 / 0010000000000000		
$N_{oc}$ at antenna port		dBm/15kHz	-98		
Symbols for unused PRBs			OCNG (Note 2)		
Number of allocated resource blocks		PRB	50		
Simultaneous transmission			Yes		
PDSCH transmission mode			9		
Number of MBSFN subframes		Subframes	NA		
dmrs-Enhancements-r13			Disabled	Enable	Enable
k-max-r14 (Note 5)			1	1	3
<p>Note 1: <math>P_B = 1</math>.</p> <p>Note 2: These physical resource blocks are assigned to an arbitrary number of virtual UEs with one PDSCH per virtual UE; the data transmitted over the OCNG PDSCHs shall be uncorrelated pseudo random data, which is QPSK modulated.</p> <p>Note 3: In Test 1, the modulation symbols of the signal under test are mapped randomly onto antenna port 7 or 8. Modulation symbols of an interference signal are mapped randomly onto one of the remaining DMRS antenna port. The two UEs' scrambling identities <math>n_{\text{SCID}}</math> are set to 0 with OCC =2.</p> <p>Note 4: In Test 2 and Test 3, the modulation symbols of the signal under test are mapped randomly onto antenna port 7, 8, 11 or 13. Modulation symbols of an interference signal are mapped randomly onto one of the remaining DMRS antenna port. The two UEs' scrambling identities <math>n_{\text{SCID}}</math> are set to 0 with OCC =4.</p> <p>Note 5: k-max-r14 is described in subclause 6.3.2 of [7].</p> <p>Note 6: The update granularity for randomized mapping antenna port is 50 PRGs in frequency domain and 1ms in time domain.</p>					

**Table 8.3.2.1J-2: Minimum performance for Minimum Performance Requirement - Single-layer Spatial Multiplexing with assistance information for simultaneous transmission interfering PDSCH (FRC)**

Test number	Bandwidth	Reference Channel	OCNG Pattern	Propagation Condition	Correlation Matrix and Antenna Configuration	Reference value		UE Category
						Fraction of Maximum Throughput (%)	SNR (dB)	
1	10 MHz	R.cc TDD	OP.1 TDD	EPA5	4x2 Low	70	15.2	$\geq 2$
2								
3								

### 8.3.2.2 Dual-Layer Spatial Multiplexing

For dual-layer transmission on antenna ports 7 and 8 upon detection of a PDCCH with DCI format 2B, the requirements are specified in Table 8.3.2.2-2, with the addition of the parameters in Table 8.3.2.2-1 and the downlink physical channel setup according to Annex C.3.2. The purpose of these tests is to verify the rank-2 performance for full RB allocation.

**Table 8.3.2.2-1: Test Parameters for Testing CDM-multiplexed DM RS (dual layer)**

Parameter	Unit	Test 1	Test 2
Downlink power allocation	$\rho_A$	dB	0
	$\rho_B$	dB	0 (Note 1)
	$\sigma$	dB	-3
Cell-specific reference symbols		Antenna port 0 and antenna port 1	
Beamforming model		Annex B.4.2	
$N_{oc}$ at antenna port	dBm/15kHz	-98	-98
Symbols for unused PRBs		OCNG (Note 2)	OCNG (Note 2)
Number of allocated resource blocks	PRB	50	50
PDSCH transmission mode		8	8
Note 1: $P_B = 1$ .			
Note 2: These physical resource blocks are assigned to an arbitrary number of virtual UEs with one PDSCH per virtual UE; the data transmitted over the OCNG PDSCHs shall be uncorrelated pseudo random data, which is QPSK modulated.			

**Table 8.3.2.2-2: Minimum performance for CDM-multiplexed DM RS (FRC)**

Test number	Bandwidth and MCS	Reference Channel	OCNG Pattern	Propagation Condition	Correlation Matrix and Antenna Configuration	Reference value		UE Category
						Fraction of Maximum Throughput (%)	SNR (dB)	
1	10 MHz QPSK 1/3	R.31 TDD	OP.1 TDD	EVA5	2x2 Low	70	4.5	$\geq 2$
2	10 MHz 16QAM 1/2	R.32 TDD	OP.1 TDD	EPA5	2x2 Medium	70	21.7	$\geq 2$

#### 8.3.2.2A Enhanced Performance Requirement Type C - Dual-Layer Spatial Multiplexing

The requirements are specified in Table 8.3.2.2A-2, with the addition of the parameters in Table 8.3.2.2A-1 and the downlink physical channel setup according to Annex C.3.2. The purpose of these tests is to verify the rank-2 performance for full RB allocation upon antenna ports 7 and 8.



Table 8.3.2.2A-1: Test Parameters for Testing CDM-multiplexed DM RS (dual layer)

Parameter	Unit	Test 1	
Downlink power allocation	$\rho_A$	dB	0
	$\rho_B$	dB	0 (Note 1)
	$\sigma$	dB	-3
Cell-specific reference symbols		Antenna port 0 and antenna port 1	
Beamforming model		Annex B.4.2	
$N_{oc}$ at antenna port	dBm/15kHz	-98	
Symbols for unused PRBs		OCNG (Note 2)	
Number of allocated resource blocks	PRB	50	
PDSCH transmission mode		8	
Note 1: $P_B = 1$ .			
Note 2: These physical resource blocks are assigned to an arbitrary number of virtual UEs with one PDSCH per virtual UE; the data transmitted over the OCNG PDSCHs shall be uncorrelated pseudo random data, which is QPSK modulated.			

Table 8.3.2.2A-2: Enhanced Performance Requirement Type C for CDM-multiplexed DM RS (FRC)

Test number	Bandwidth and MCS	Reference Channel	OCNG Pattern	Propagation Condition	Correlation Matrix and Antenna Configuration	Reference value		UE Category
						Fraction of Maximum Throughput (%)	SNR (dB)	
1	10 MHz 16QAM 1/2	R.32 TDD	OP.1 TDD	EPA5	2x2 Medium	70	17.0	$\geq 2$

### 8.3.2.3 Dual-Layer Spatial Multiplexing (with multiple CSI-RS configurations)

For dual-layer transmission on antenna ports 7 and 8 upon detection of a PDCCH with DCI format 2C, the requirements are specified in Table 8.3.2.3-2, with the addition of the parameters in Table 8.3.2.3-1 where Cell 1 is the serving cell and Cell 2 is the interfering cell. The downlink physical channel setup is set according to Annex C.3.2. The purpose of these tests is to verify the rank-2 performance for full RB allocation, to verify rate matching with multiple CSI reference symbol configurations with non-zero and zero transmission power, and to verify that the UE correctly estimate SNR.

Table 8.3.2.3-1: Test Parameters for Testing CDM-multiplexed DM RS (dual layer) with multiple CSI-RS configurations

Parameter	Unit	Test 1		
		Cell 1	Cell 2	
Downlink power allocation	$\rho_A$	dB	0	0
	$\rho_B$	dB	0 (Note 1)	0
	$\sigma$	dB	-3	-3
	PDSCH_RA	dB	4	NA
	PDSCH_RB	dB	4	NA

Cell-specific reference signals		Antenna ports 0 and 1	Antenna ports 0 and 1
Cell ID		0	126
CSI reference signals		Antenna ports 15,16	NA
Beamforming model		Annex B.4.2	NA
CSI-RS periodicity and subframe offset $T_{\text{CSI-RS}} / \Delta_{\text{CSI-RS}}$	Subframes	5 / 4	NA
CSI reference signal configuration		8	NA
Zero-power CSI-RS configuration $I_{\text{CSI-RS}} / \text{ZeroPowerCSI-RS}$ bitmap	Subframes / bitmap	4 / 0010000000000000	NA
$N_{oc}$ at antenna port	dBm/15kHz	-98	-98
$E_s / N_{oc}$		Reference Value in Table 8.3.2.3-2	Test specific, 7.25dB
Symbols for unused PRBs		OCNG (Note 2)	NA
Number of allocated resource blocks (Note 2)	PRB	50	NA
Simultaneous transmission		No	NA
PDSCH transmission mode		9	Blanked
Note 1: $P_b = 1$ Note 2: These physical resource blocks are assigned to an arbitrary number of virtual UEs with one PDSCH per virtual UE; the data transmitted over the OCNG PDSCHs shall be uncorrelated pseudo random data, which is QPSK modulated.			

**Table 8.3.2.3-2: Minimum performance for CDM-multiplexed DM RS (FRC) with multiple CSI-RS configurations**

Test number	Bandwidth and MCS	Reference Channel	OCNG Pattern		Propagation Condition		Correlation Matrix and Antenna Configuration	Reference value		UE Category
			Cell 1	Cell 2	Cell 1	Cell 2		Fraction of Maximum Throughput (%)	SNR (dB)	
1	10 MHz 16QAM 1/2	R.51 TDD	OP.1 TDD	N/A	ETU5	ETU5	2x2 Low	70	14.8	$\geq 2$
Note 1: The propagation conditions for Cell 1 and Cell 2 are statistically independent. Note 2: Correlation matrix and antenna configuration parameters apply for each of Cell 1 and Cell 2. Note 3: SNR corresponds to $E_s / N_{oc}$ of Cell 1.										

### 8.3.2.4 Performance requirements for DCI format 2D and non Quasi Co-located Antenna Ports

#### 8.3.2.4.1 Minimum requirement with Same Cell ID (with single NZP CSI-RS resource)

The requirements are specified in Table 8.3.2.4.1-3, with the additional parameters in Table 8.3.2.4.1-1 and Table 8.3.2.4.1-2. The purpose of this test is to verify the UE capability of supporting non quasi-co-located antenna ports when the UE receives DCI format 2D in a scenario where the two transmission point share the same Cell ID. In particular the test verifies that the UE, configured with quasi co-location type B, performs correct tracking and compensation of the

timing difference between two transmission points, channel parameters estimation and rate matching according to the 'PDSCH RE Mapping and Quasi-Co-Location Indicator' (PQI) signalling defined in [6], configured according to Table 8.3.2.4.1-2. In Tables 8.3.2.4.1-1 and 8.3.2.4.1-2, transmission point 1 (TP 1) is the serving cell and transmission point 2 (TP 2) transmits PDSCH. The downlink physical channel setup for TP 1 is according to Table C.3.4-1 and for TP 2 according to Table C.3.4-2.

**Table 8.3.2.4.1-1: Test Parameters for quasi co-location type B: same Cell ID**

Parameter	Unit	TP 1	TP 2
Downlink power allocation	$\rho_A$	0	0
	$\rho_B$	0 (Note 1)	0
	$\sigma$	-3	-3
Cell-specific reference signals		Antenna ports 0,1	(Note 2)
CSI-RS 0 antenna ports		NA	Port {15,16}
<i>qcl-CSI-RS-ConfigNZPId-r11</i> , CSI-RS 0 periodicity and subframe offset $T_{CSI-RS} / \Delta_{CSI-RS}$	Subframes	NA	5/4
<i>qcl-CSI-RS-ConfigNZPId-r11</i> , CSI-RS 0 configuration		NA	8
<i>csi-RS-ConfigZPId-r11</i> , Zero-power CSI-RS 0 configuration $I_{CSI-RS} / ZeroPower\ CSI-RS\ bitmap$		NA	4/ 0000010000000000
$N_{oc}$ at antenna port	dBm/15kHz	-98	-98
$E_s / N_{oc}$	dB	Reference point in Table 8.3.2.4.1-3	Reference point in Table 8.3.2.4.1-3
$BW_{channel}$	MHz	10	10
Cyclic Prefix		Normal	Normal
Cell Id		0	0
Number of control OFDM symbols		2	2
PDSCH transmission mode		Blanked	10
Number of allocated PRB	PRB	NA	50
<i>qcl-Operation</i> , 'PDSCH RE Mapping and Quasi-Co-Location Indicator'		Type B, '00'	
Time offset between TPs	$\mu s$	NA	Reference point in Table 8.3.2.4.1-3
Frequency error between TPs	Hz	NA	0
Beamforming model		NA	Port 7 as specified in clause B.4.1
Symbols for unused PRBs		NA	OCNG (Note 3)
Note 1: $P_B = 1$ Note 2: REs for antenna ports 0 and 1 have zero transmission power. Note 3: These physical resource blocks are assigned to an arbitrary number of virtual UEs with one PDSCH per virtual UE; the data transmitted over the OCNG PDSCHs shall be uncorrelated pseudo random data, which is QPSK modulated.			

**Table 8.3.2.4.1-2: Configurations of PQI and DL transmission hypothesis for each PQI set**

PQI set index	Parameters in each PQI set	DL transmission hypothesis for each PQI Set

	NZP CSI-RS Index (For quasi co-location)	ZP CSI-RS configuration	TP 1	TP 2
PQI set 0	CSI-RS 0	ZP CSI-RS 0	Blanked	PDSCH

Table 8.3.2.4.1-3: Minimum performance for quasi co-location type B: same Cell ID

Test Number	Reference Channel	OGCN pattern		Time offset between TPs ( $\mu$ s)	Propagation Conditions (Note1)		Correlation Matrix and Antenna Configuration (Note 2)	Reference Value		UE Category
		TP 1	TP 2		TP 1	TP 2		Fraction of Maximum Throughput (%)	SNR (dB) (Note 3)	
1	R.52 TDD	NA	OP.1 TDD	2	EPA5	EPA5	2x2 Low	70	12	$\geq 2$
2	R.52 TDD	NA	OP.1 TDD	-0.5	EPA5	EPA5	2x2 Low	70	12.4	$\geq 2$

Note 1: The propagation conditions for TP 1 and TP 2 are statistically independent.  
Note 2: The correlation matrix and antenna configuration apply for TP 1 and TP 2.  
Note 3: SNR corresponds to  $\hat{E}_s / N_{oc}$  of TP 2 as defined in clause 8.1.1.

#### 8.3.2.4.2 Minimum requirements with Same Cell ID (with multiple NZP CSI-RS resources)

The requirements are specified in Table 8.3.2.4.2-3, with the additional parameters in Tables 8.3.2.4.2-1 and 8.3.2.4.2-2. The purpose of this test is to verify the UE capability of supporting non quasi-co-located antenna ports when the UE receives DCI format 2D in a scenario where the two transmission point share the same Cell ID. In particular the test verifies that the UE, configured with quasi co-location type B, performs correct tracking and compensation of the timing difference between two transmission points, channel parameters estimation and rate matching according to the 'PDSCH RE Mapping and Quasi-Co-Location Indicator' (PQI) signalling defined in [6]. In Tables 8.3.2.4.2-1 and 8.3.2.4.2-2, transmission point 1 (TP 1) is the serving cell transmitting PDCCH, synchronization signals and PBCH, and transmission point 2 (TP 2) has same Cell ID as TP 1. Multiple NZP CSI-RS resources and ZP CSI-RS resources are configured. In each sub-frame, DL PDSCH transmission is dynamically switched between 2 TPs with multiple PDSCH RE Mapping and Quasi-Co-Location Indicator configuration (PQI). Configurations of PDSCH RE Mapping and Quasi-Co-Location Indicator and downlink transmission hypothesis are defined in Table 8.3.2.4.2-2. The downlink physical channel setup for TP 1 is according to Table C.3.4-1 and for TP 2 according to Table C.3.4-2.

Table 8.3.2.4.2-1: Test Parameters for timing offset compensation with DPS transmission

parameter	Unit	TP 1	TP 2
Downlink power allocation	$\rho_A$	dB	0
	$\rho_B$	dB	0 (Note 1)
	$\sigma$	dB	-3

Beamforming model		As specified in clause B.4.1	As specified in clause B.4.1
Cell-specific reference signals		Antenna ports 0,1	(Note 2)
CSI reference signals 0		Antenna ports {15,16}	N/A
CSI-RS 0 periodicity and subframe offset $T_{\text{CSI-RS}} / \Delta_{\text{CSI-RS}}$	Subframes	5 / 4	N/A
CSI reference signal 0 configuration		0	N/A
CSI reference signals 1		N/A	Antenna ports {15,16}
CSI-RS 1 periodicity and subframe offset $T_{\text{CSI-RS}} / \Delta_{\text{CSI-RS}}$	Subframes	N/A	5 / 4
CSI reference signal 1 configuration		N/A	8
Zero-power CSI-RS 0 configuration $I_{\text{CSI-RS}} /$ <i>ZeroPower CSI-RS</i> bitmap	Subframes /bitmap	4/ 0010000000000000	N/A
Zero-power CSI-RS1 configuration $I_{\text{CSI-RS}} /$ <i>ZeroPower CSI-RS</i> bitmaps	Subframes /bitmap	N/A	4/ 0000010000000000
$E_s / N_{oc}$	dB	Reference Value in Table 8.3.2.4.2-3	Reference Value in Table 8.3.2.4.2-3
$N_{oc}$ at antenna port	dBm/15kHz	-98	-98
$BW_{\text{Channel}}$	MHz	10	10
Cyclic Prefix		Normal	Normal
Cell Id		0	0
Number of control OFDM symbols		2	2
Timing offset between TPs		N/A	Reference Value in Table 8.3.2.4.2-3
Frequency offset between TPs	Hz	N/A	0
Number of allocated resource blocks	PRB	50	50
PDSCH transmission mode		10	10
Probability of occurrence of PDSCH transmission (Note 3)	%	30	70
Symbols for unused PRBs		OCNG (Note 4)	OCNG (Note 4)
<p>Note 1: <math>P_B = 1</math></p> <p>Note 2: REs for antenna ports 0 and 1 have zero transmission power.</p> <p>Note 3: PDSCH transmission from TPs shall be randomly determined independently for each subframe. Probabilities of occurrence of PDSCH transmission from TPs are specified.</p> <p>Note 4: These physical resource blocks are assigned to an arbitrary number of virtual UEs with one PDSCH per virtual UE; the data transmitted over the OCNG PDSCHs shall be uncorrelated pseudo random data, which is QPSK modulated.</p>			

Table 8.3.2.4.2-2: Configurations of PQI and DL transmission hypothesis for each PQI set

PQI set index	Parameters in each PQI set		DL transmission hypothesis for each PQI Set	
	NZP CSI-RS Index (For quasi co-location)	ZP CSI-RS configuration	TP 1	TP 2
PQI set 0	CSI-RS 0	ZP CSI-RS 0	PDSCH	Blanked
PQI set 1	CSI-RS 1	ZP CSI-RS 1	Blanked	PDSCH

Table 8.3.2.4.2-3: Performance Requirements for timing offset compensation with DPS transmission

Test Number	Timing offset(us)	Reference Channel	OCNG Pattern		Propagation Conditions		Correlation Matrix and Antenna Configuration (Note 2)	Reference Value		UE Category
			TP 1	TP 2	TP 1	TP 2		Fraction of Maximum Throughput (%)	SNR (dB) (Note 3)	
1	2	R.53 TDD	OP.1 TDD	OP.1 TDD	EPA5	EPA5	2x2 Low	70	12.3	≥2
2	-0.5	R.53 TDD	OP.1 TDD	OP.1 TDD	EPA5	EPA5	2x2 Low	70	12.5	≥2

Note 1: The propagation conditions for TP 1 and TP 2 are statistically independent.  
Note 2: Correlation matrix and antenna configuration parameters apply for each of TP 1 and TP 2.  
Note 3: SNR corresponds to  $E_s/N_{oc}$  of both TP 1 and TP 2 as defined in clause 8.1.1.

### 8.3.2.4.3 Minimum requirement with Different Cell ID and Colliding CRS (with single NZP CSI-RS resource)

The requirements are specified in Table 8.3.2.4.3-2, with the additional parameters in Table 8.3.2.4.3-1. The purpose of this test is to verify the UE capability of supporting non quasi-co-located antenna ports when the UE receives DCI format 2D in a scenario where the two transmission points have different Cell ID and colliding CRS. In particular the test verifies that the UE, configured with quasi co-location type B, performs correct tracking and compensation of the frequency difference between two transmission points, channel parameters estimation and rate matching behaviour according to the 'PDSCH RE Mapping and Quasi-Co-Location Indicator' signalling defined in [6]. In Table 8.3.2.4.3-1, transmission point 1 (TP 1) is serving cell transmitting PDCCH, synchronization signals and PBCH, and transmission point 2 (TP 2) transmits PDSCH with different Cell ID. The downlink physical channel setup for TP 1 is according to Table C.3.4-1 and for TP 2 according to Table C.3.4-2.

Table 8.3.2.4.3-1: Test Parameters for quasi co-location type B with different Cell ID and Colliding CRS

parameter	Unit	TP 1	TP 2
Downlink power allocation	$\rho_A$	dB	0
	$\rho_B$	dB	0 (Note 1)
	$\sigma$	dB	-3

Beamforming model		N/A	As specified in clause B.4.2
Cell-specific reference signals		Antenna ports 0,1	Antenna ports 0,1
CSI reference signals 0		N/A	Antenna ports {15,16}
CSI-RS 0 periodicity and subframe offset $T_{CSI-RS} / \Delta_{CSI-RS}$	Subframes	N/A	5 / 4
CSI reference signal 0 configuration		N/A	0
Zero-power CSI-RS 0 configuration $I_{CSI-RS} / ZeroPower\ CSI-RS\ bitmap$	Subframes /bitmap	N/A	4/ 0010000000000000
$E_s / N_{oc}$	dB	Reference point in Table 8.3.2.4.3-2 + 4dB	Reference Value in Table 8.3.2.4.3-2
$N_{oc}$ at antenna port	dBm/15kHz	-98	-98
$BW_{channel}$	MHz	10	10
Cyclic Prefix		Normal	Normal
Cell Id		0	126
Number of control OFDM symbols		1	2
Timing offset between TPs	us	N/A	0
Frequency offset between TPs	Hz	N/A	200
<i>qcl-Operation</i> , 'PDSCH RE Mapping and Quasi-Co-Location Indicator'		Type B, '00'	
PDSCH transmission mode		Blank	10
Number of allocated resource block		N/A	50
Symbols for unused PRBs		N/A	OCNG(Note2)
Note 1: $P_B = 1$			
Note 2: These physical resource blocks are assigned to an arbitrary number of virtual UEs with one PDSCH per virtual UE; the data transmitted over the OCNG PDSCHs shall be uncorrelated pseudo random data, which is QPSK modulated.			

**Table 8.3.2.4.3-2: Performance Requirements for quasi co-location type B with different Cell ID and Colliding CRS**

Test Number	Reference Channel	OCNG Pattern		Propagation Conditions (Note1)		Correlation Matrix and Antenna Configuration (Note 2)	Reference Value		UE Category
		TP 1	TP 2	TP 1	TP 2		Fraction of Maximum Throughput (%)	SNR (dB) (Note 3)	
1	R.54 TDD	N/A	OP.1 TDD	EPA5	ETU5	2x2 Low	70	14.7	≥2
Note 1: The propagation conditions for TP 1 and TP 2 are statistically independent.									
Note 2: Correlation matrix and antenna configuration parameters apply for each of TP 1 and TP 2.									
Note 3: SNR corresponds to $E_s / N_{oc}$ of TP 2 as defined in clause 8.1.1.									

#### 8.3.2.4.4 Minimum requirement with Different Cell ID and non-Colliding CRS (with single NRP CSI-RS resource and CRS assistance information is configured)

The requirements are specified in Table 8.3.2.4.4-3, with the additional parameters in Table 8.3.2.4.4-1 and Table 8.3.2.4.4-2. The purpose of this test is to verify the UE capability of supporting non quasi-co-located antenna ports when the UE receives DCI format 2D in a scenario where three transmission points have different Cell ID and non-colliding CRS. In particular the test verifies that the UE, configured with quasi co-location type B, performs correct tracking and compensation of the frequency difference and time difference between two transmission points, channel parameters estimation and rate matching behaviour according to the 'PDSCH RE Mapping and Quasi-Co-Location Indicator' signalling defined in [6]. Further, the test verifies that the UE, configured with the CRS assistance information [7], can mitigate interference from CRS for demodulation. The CRS assistance information [7] includes TP 3. In Table 8.3.2.4.4-1, transmission point 1 (TP 1) is serving cell transmitting PDCCH, synchronization signals and PBCH, transmission point 2 (TP 2) transmits PDSCH with different Cell ID, and Transmission point 3 (TP 3) is the aggressor transmission point. The downlink physical channel setup for TP 1 is according to Table C.3.4-1, for TP 2 is according to Table C.3.4-2, and for TP 3 is according to Annex C.3.2.



**Table 8.3.2.4.4-1: Test Parameters for quasi co-location type B with different Cell ID and non-colliding CRS when CRS assistance information is configured**

parameter	Unit	TP 1	TP 2	TP 3
Downlink power allocation	$\rho_A$	dB	0	0
	$\rho_B$	dB	0 (Note 1)	0
	$\sigma$	dB	-3	-3
Beamforming model		N/A	Port 7 as specified in clause B.4.1	N/A
Cell-specific reference signals		Antenna ports 0,1	Antenna ports 0,1	Antenna ports 0,1
CSI reference signals 0		N/A	Antenna ports {15,16}	N/A
CSI-RS 0 periodicity and subframe offset $T_{CSI-RS} / \Delta_{CSI-RS}$	Subframes	N/A	5 / 4	N/A
CSI reference signal 0 configuration		N/A	0	N/A
Zero-power CSI-RS 0 configuration $l_{CSI-RS} / \text{ZeroPower CSI-RS bitmap}$	Subframes /bitmap	N/A	4/ 0010000000000000	N/A
$E_s / N_{oc}$	dB	10.45	Reference Value in Table 8.3.2.4.4-3	8.45
$N_{oc}$ at antenna port	dBm/15kHz	-98	-98	N/A
$BW_{\text{Channel}}$	MHz	10	10	10
Cyclic Prefix		Normal	Normal	Normal
Cell Id		0	1	128
Number of control OFDM symbols		1	2	2
Timing offset to TP 1	us	N/A	-0.5	3
Frequency offset to TP 1	Hz	N/A	200	-100
<i>qcl-Operation</i> , 'PDSCH RE Mapping and Quasi-Co-Location Indicator'		Type B, '00'		N/A
PDSCH transmission mode		Blank	10	9
Number of allocated resource block		N/A	50	N/A
Symbols for unused PRBs		N/A	OCNG(Note2)	N/A
Interference model		N/A	N/A	As specified in clause B.5.4
Probability of occurrence of transmission in interference cells	%	N/A	N/A	20
Probability of occurrence of transmission rank in interfering cells	Rank 1	%	N/A	80
	Rank 2	%	N/A	20
Note 1: $P_B = 1$				
Note 2: These physical resource blocks are assigned to an arbitrary number of virtual UEs with one PDSCH per virtual UE; the data transmitted over the OCNG PDSCHs shall be uncorrelated pseudo random data, which is QPSK modulated.				

Table 8.3.2.4.4-2: Configurations of PQI and DL transmission hypothesis for each PQI set

PQI set index	Parameters in each PQI set		DL transmission hypothesis for each PQI Set	
	NZP CSI-RS Index (For quasi co-location)	ZP CSI-RS configuration	TP 1	TP 2
PQI set 0	CSI-RS 0	ZP CSI-RS 0	Blanked	PDSCH

Table 8.3.2.4.4-3: Performance Requirements for quasi co-location type B with different Cell ID and non-Colliding CRS when CRS assistance information is configured

Test Number	Reference Channel	OCNG Pattern			Propagation Conditions (Note1)			Correlation Matrix and Antenna Configuration (Note 2)	Reference Value		UE Category
		TP 1	TP 2	TP3	TP 1	TP 2	TP3		Fraction of Maximum Throughput (%)	SNR (dB) (Note 3)	
1	R.52-1 TDD	N/A	OP.1 TDD	N/A	EVA5	EVA5	EVA5	2x2 Low	70	11.1	≥2

Note 1: The propagation conditions for TP.1, TP.2 and TP.3 are statistically independent.

Note 2: Correlation matrix and antenna configuration parameters apply for each of TP.1, TP.2 and TP.3.

Note 3: SNR corresponds to  $E_s/N_{oc}$  of TP.2 as defined in clause 8.1.1.

#### 8.3.2.4.5 Minimum requirements with different Cell ID and non-colliding CRS (with multiple NZP CSI-RS resources and CRS assistance information is configured)

The requirements are specified in Table 8.3.2.4.5-3, with the additional parameters in Tables 8.3.2.4.5-1 and 8.3.2.4.5-2. The purpose of this test is to verify the UE capability of supporting non quasi-colocated antenna ports when the UE receives DCI format 2D in a scenario where three transmission points have the different Cell ID and non-colliding CRS. In particular the test verifies that the UE, configured with quasi co-location type B, performs correct tracking and compensation of the frequency difference and timing difference between two transmission points, channel parameters estimation and rate matching according to the 'PDSCH RE Mapping and Quasi-Co-Location Indicator' (PQI) signalling defined in [6]. Further, the test verifies that the UE, configured with the CRS assistance information [7], can mitigate interference from CRS for demodulation. The CRS assistance information [7] includes TP 3. In Tables 8.3.2.4.5-1 and 8.3.2.4.5-2, transmission point 1 (TP 1) is the serving cell transmitting PDCCH, synchronization signals and PBCH, Transmission point 2 (TP 2) has different Cell ID as TP 1, and Transmission point 3 (TP3) is the aggressor transmission point. Multiple NZP CSI-RS resources and ZP CSI-RS resources are configured. In each sub-frame, DL PDSCH transmission is dynamically switched between TP 1 and TP 2 with multiple PDSCH RE Mapping and Quasi-Co-Location Indicator configuration (PQI). Configurations of PDSCH RE Mapping and Quasi-Co-Location Indicator and downlink transmission hypothesis are defined in Table 8.3.2.4.5-2. The downlink physical channel setup for TP 1 is according to Table C.3.4-1, for TP 2 is according to Table C.3.4-2, and for TP 3 is according to Annex C.3.2

**Table 8.3.2.4.5-1: Test Parameters for DPS transmission with CRS assistance information**

parameter	Unit	TP 1	TP 2	TP 3	
Downlink power allocation	$\rho_A$	dB	0	0	
	$\rho_B$	dB	0 (Note 1)	0	
	$\sigma$	dB	-3	-3	
Beamforming model		As specified in clause B.4.1	As specified in clause B.4.1	N/A	
Cell-specific reference signals		Antenna ports 0,1	Antenna ports 0,1	Antenna ports 0,1	
CSI reference signals 0		Antenna ports {15,16}	N/A	N/A	
CSI-RS 0 periodicity and subframe offset $T_{CSI-RS} / \Delta_{CSI-RS}$	Subframes	5 / 4	N/A	N/A	
CSI reference signal 0 configuration		0	N/A	N/A	
CSI reference signals 1		N/A	Antenna ports {15,16}	N/A	
CSI-RS 1 periodicity and subframe offset $T_{CSI-RS} / \Delta_{CSI-RS}$	Subframes	N/A	5 / 4	N/A	
CSI reference signal 1 configuration		N/A	8	N/A	
Zero-power CSI-RS 0 configuration $l_{CSI-RS} / \text{ZeroPower CSI-RS bitmap}$	Subframes /bitmap	4/ 0010000000000000	N/A	N/A	
Zero-power CSI-RS1 configuration $l_{CSI-RS} / \text{ZeroPower CSI-RS bitmaps}$	Subframes /bitmap	N/A	4/ 0000010000000000	N/A	
$E_s / N_{oc}$ (Note 2)	dB	Reference Value in Table 8.3.2.4.5-3	Reference Value in Table 8.3.2.4.5-3	8.45	
$N_{oc}$ at antenna port	dBm/15kHz	-98	-98	N/A	
$BW_{\text{Channel}}$	MHz	10	10	10	
Cyclic Prefix		Normal	Normal	Normal	
Cell Id		0	1	128	
Number of control OFDM symbols		2	2	2	
Timing offset to TP 1		N/A	-0.5	3	
Frequency offset to TP 1	Hz	N/A	200	-100	
Number of allocated resource blocks	PRB	50	50	N/A	
PDSCH transmission mode		10	10	9	
Probability of occurrence of PDSCH transmission(Note 3)	%	30	70	N/A	
Symbols for unused PRBs		OCNG (Note 4)	OCNG (Note 4)	N/A	
Interference model		N/A	N/A	As specified in clause B.5.4	
Probability of occurrence of transmission in interference cells	%	N/A	N/A	20	
Probability of occurrence of transmission rank in interfering cells	Rank 1	%	N/A	N/A	80
	Rank 2	%	N/A	N/A	20

Note 1:	$P_b = 1$
Note 2:	$E_s/N_{oc}$ of TP 1 is set the same as that of TP 2.
Note 3:	PDSCH transmission from TP 1 and TP 2 shall be randomly determined independently for each subframe. Probabilities of occurrence of PDSCH transmission from TPs are specified.
Note 4:	These physical resource blocks are assigned to an arbitrary number of virtual UEs with one PDSCH per virtual UE; the data transmitted over the OCNG PDSCHs shall be uncorrelated pseudo random data, which is QPSK modulated.

Table 8.3.2.4.5-2: Configurations of PQI and DL transmission hypothesis for each PQI set

PQI set index	Parameters in each PQI set		DL transmission hypothesis for each PQI Set	
	NZP CSI-RS Index (For quasi co-location)	ZP CSI-RS configuration	TP 1	TP 2
PQI set 0	CSI-RS 0	ZP CSI-RS 0	PDSCH	Blanked
PQI set 1	CSI-RS 1	ZP CSI-RS 1	Blanked	PDSCH

Table 8.3.2.4.5-3: Performance Requirements for DPS transmission with CRS assistance information

Test Number	Reference Channel	OCNG Pattern			Propagation Conditions (Note1)			Correlation Matrix and Antenna Configuration (Note 2)	Reference Value		UE Category
		TP 1	TP 2	TP3	TP 1	TP 2	TP3		Fraction of Maximum Throughput (%)	SNR (dB) (Note 3)	
1	R.52-1 TDD	OP.1 TDD	OP.1 TDD	N/A	EVA5	EVA5	EVA5	2x2 Low	70	11.2	≥2
Note 1: The propagation conditions for TP.1, TP.2 and TP.3 are statistically independent.											
Note 2: Correlation matrix and antenna configuration parameters apply for each of TP.1, TP.2 and TP.3.											
Note 3: SNR corresponds to $E_s/N_{oc}$ of both TP.1 and TP.2 as defined in clause 8.1.1.											

### 8.3.2.4.6 Minimum requirements for QCL Type C and 2 Layers Spatial Multiplexing

The requirements are specified in Table 8.3.2.4.6-3, with the additional parameters in Table 8.3.2.4.6-1 and Table 8.3.2.4.6-2. The purpose of this test is to verify the UE capability of supporting non quasi-co-located antenna ports when the UE receives DCI format 2D in a scenario with non-coherent joint transmission from two transmission points. The test verifies that the UE configured with quasi co-location type C performs correct tracking and compensation of the frequency and time difference between two transmission points, channel parameters estimation, channel estimation and rate matching behaviour according to the 'PDSCH RE Mapping and Quasi-Co-Location Indicator' signalling defined in [6]. In Table 8.3.2.4.6-1, transmission point 1 (TP 1) is the serving cell transmitting PDCCH, synchronization signals, PBCH and PDSCH, and transmission point 2 (TP 2) has different Cell ID and transmits PDSCH. In the test the PDSCH is transmitted from TP 1 and TP 2. The downlink physical channel setup for TP 1 is according to Annex C.3.2 and for TP 2 according to Annex C.3.2.

Table 8.3.2.4.6-1: Test Parameters

Parameter	Unit	TP 1	TP 2
Uplink downlink configuration		1	1
Special subframe configuration		4	4
Downlink power allocation	$\rho_A$	dB	0
	$\rho_B$	dB	0 (Note 1)
	$\sigma$	dB	-3
Beamforming model		Random beamforming (rank 1)	Random beamforming (rank 1)
Cell-specific reference signals		Antenna ports 0,1	Antenna ports 0,1
CSI reference signals 0		Antenna ports {15,16}	N/A
CSI-RS 0 periodicity and subframe offset $T_{\text{CSI-RS}} / \Delta_{\text{CSI-RS}}$	Subframes	5 / 4	
CSI reference signal 0 configuration		0	
CSI reference signals 1		N/A	Antenna ports {15,16}
CSI-RS 1 periodicity and subframe offset $T_{\text{CSI-RS}} / \Delta_{\text{CSI-RS}}$	Subframes		5 / 4
CSI reference signal 1 configuration			8
Zero-power CSI-RS 0 configuration $I_{\text{CSI-RS}} / \text{ZeroPower CSI-RS}$ bitmap	Subframes/bitmap	4/ 0010000000000000	N/A
Zero-power CSI-RS1 configuration $I_{\text{CSI-RS}} / \text{ZeroPower CSI-RS}$ bitmap	Subframes/bitmap	N/A	4/ 0010000000000000
$E_s / N_{oc}$	dB	SNR1	SNR2 = SNR1
$N_{oc}$ at antenna port	dBm/15kHz	-98	-98
$BW_{\text{Channel}}$	MHz	10	10
Cyclic Prefix		Normal	Normal
Cell ID		0	126
Number of control OFDM symbols / PDSCH start		2	2
Timing offset relative to TP 1	us	N/A	2
Frequency offset relative to TP 1	Hz	N/A	200
<i>qcl-Operation</i> , 'PDSCH RE Mapping and Quasi-Co-Location Indicator'		Type C, '00'	
PDSCH transmission mode (Note 2)		10	10
Number of allocated resource block		50	50
Note 1: $P_B = 1$ Note 2: PDSCH transmission is done from both TPs (CW1 is transmitted from TP 1 and CW2 is transmitted from TP 2)			

Table 8.3.2.4.6-2: Configurations of PQI and DL transmission hypothesis for each PQI set

PQI set index	Parameters in each PQI set		DL transmission hypothesis for each PQI Set	
	NZP CSI-RS Index (For quasi co-location)	ZP CSI-RS configuration	TP 1	TP 2
PQI set 0	CSI-RS 0 for CW1 CSI-RS 1 for CW2	ZP CSI-RS 0	PDSCH	PDSCH

Table 8.3.2.4.6-3: Performance Requirements

Test Number	Reference Channel		OCNG Pattern		Propagation Conditions (Note1)		Correlation Matrix and Antenna Configuration (Note 2)	Reference Value		UE Category
	TP 1	TP 2	TP 1	TP 2	TP 1	TP 2		Fraction of Maximum Throughput (%)	SNR1 (dB) (Note 3)	
1	R.97 TDD	[R.97 TDD	OP.1T DD	OP.1T DD	EPA5	EPA5	2x2 Low	70	10.7	≥2

Note 1: The propagation conditions for TP 1 and TP 2 are statistically independent.

Note 2: Correlation matrix and antenna configuration parameters apply for each of TP 1 and TP 2.

Note 3: SNR corresponds to  $E_s/N_{oc}$  of TP 1 and TP 2 as defined in clause 8.1.1.

### 8.3.2.5 Performance Requirements for semiOpenLoop transmission

The requirements are specified in Table 8.3.2.5-2, with the addition of the parameters in Table 8.3.2.5-1 and the downlink physical channel setup according to Annex C.3.2. The purpose of these tests is to verify rank one and rank two performances for full RB allocation upon antenna ports 7 and 8 with higher layer parameter *semiOpenLoop* is configured.

**Table 8.3.2.5-1: Test Parameters for Testing CDM-multiplexed DM RS (dual layer) when high layer parameter *semiOpenLoop* is configured**

parameter	Unit	Test 1	Test 2
Downlink power allocation	$\rho_A$	dB	0
	$\rho_B$	dB	0 (Note 1)
	$\sigma$	dB	-3
Cell-specific reference signals		Antenna ports 0 and 1	Antenna ports 0 and 1
CSI reference signals		Antenna ports 15,16	Antenna ports 15,16,17,18
Beamforming model		B.4.3 (Note 3)	B.4.3 (Note 3)
CSI-RS periodicity and subframe offset $T_{\text{CSI-RS}} / \Delta_{\text{CSI-RS}}$	Subframes	5 / 4	5 / 4
CSI reference signal configuration		0	0
Zero-power CSI-RS configuration $k_{\text{CSI-RS}} / \text{ZeroPowerCSI-RS bitmap}$	Subframes / bitmap	4/ 0010000000000000	4/ 0010000000000000
$N_{oc}$ at antenna port	dBm/15kHz	-98	-98
Symbols for unused PRBs		OCNG (Note 2)	OCNG (Note 2)
Number of allocated resource blocks (Note 2)	PRB	50	50
Simultaneous transmission		No	No
PDSCH transmission mode		9	9
Rank Number of PDSCH		1	2
<i>semiOpenLoop</i>		True	True
<p>Note 1: <math>P_B = 1</math></p> <p>Note 2: These physical resource blocks are assigned to an arbitrary number of virtual UEs with one PDSCH per virtual UE; the data transmitted over the OCNG PDSCHs shall be uncorrelated pseudo random data, which is QPSK modulated.</p> <p>Note 3: For 2 antenna ports {15, 16}, the precoding matrix corresponding to codebook index 0 from Table 6.3.4.2.3-1 in [4] with <math>\nu = 1</math> ;  For 4 antenna ports { 15,16,17,18 }, the precoding matrix random selected from Table 6.3.4.2.3-2 in [4] with <math>\nu = 2</math></p>			

**Table 8.3.2.5-2: Minimum Performance Requirements for CDM-multiplexed DM RS (FRC) when high layer parameter *semiOpenLoop* is configured**

Test number	Bandwidth and MCS	Reference Channel	OCNG Pattern	Propagation Condition	Correlation Matrix and Antenna Configuration	Reference value		UE Category
						Fraction of Maximum Throughput (%)	SNR (dB)	
1	10 MHz QPSK 1/3	R.76A TDD	OP.1 TDD	EVA 70Hz	2x2 Medium	70	[0.9]	$\geq 1$
2	10 MHz 16QAM 1/2	R.61A TDD	OP.1 TDD	EVA 70Hz	4x2 Low	70	[15.6]	$\geq 2$



### 8.3.3 LAA

#### 8.3.3.1 Dual-Layer Spatial Multiplexing with DM-RS

##### 8.3.3.1.1 FDD PCell (FDD single carrier)

The parameters specified in Table 8.3.3.1.1-1 are valid for FDD CC and LAA SCell(s) unless otherwise stated. And the additional parameters specified in Table 8.3.3.1.1-2 are valid for LAA SCell(s).

**Table 8.3.3.1.1-1: Common Test Parameters**

Parameter	Unit	Value
Cyclic prefix		Normal
Cell ID		0
Inter-TTI Distance		1
Number of HARQ processes	Processes	8
Maximum number of HARQ transmission (Note 1)		4
Redundancy version coding sequence		{0,1,2,3} for QPSK and 16QAM {0,0,1,2} for 64QAM and 256QAM
Precoder update granularity		Frequency domain: 1 PRG Time domain: 1 ms
Note 1:	For retransmission in partial subframes, the TB size should be kept the same as the initial transmission regardless of the initial transmission is performed in full subframes or partial subframes.	
Note 2:	Void.	

**Table 8.3.3.1.1-2: Additional Test Parameters for LAA SCell(s)**

Parameter	Unit	Value
DMTC Periodicity	ms	80
dmtc-PeriodOffset-r12 ms80-r12		0
Discovery signal occasion duration	subframe	1
Power allocation of discovery signal		Same as power allocation of CRS within a transmission burst in the test

For CA with LAA SCell(s), the requirements for dual-layer transmission on antenna ports 7 and 8 upon detection of a PDCCH with DCI format 2C are specified in Table 8.3.3.1.1-7, with the addition of the parameters in Table 8.3.3.1.1-3, Table 8.3.3.1.1-4 and Table 8.3.3.1.1-5. The downlink physical channel setup is set according to Annex C.3.2. The purpose of these tests is to verify the rank-2 performance for full RB allocation for CA with LAA SCell(s).

Table 8.3.3.1.1-3: Test Parameters for Large Delay CDD (FRC) for PCell

Parameter	Unit	Value	
Downlink power allocation	$\rho_A$	dB	-3
	$\rho_B$	dB	-3 (NOTE 1)
	$\sigma$	dB	0
$N_{oc}$ at antenna port	dBm/15kHz	-98	
PDSCH transmission mode		TM3	
Subframe configuration		Non-MBSFN	
NOTE 1: $P_B = 1$ .			
NOTE 2: PUCCH format 3 is used to feedback ACK/NACK.			
NOTE 3: Void.			

Table 8.3.3.1.1-4: Test Parameters for CDM-multiplexed DM RS (dual layer) for CA with LAA SCell(s)

Parameter	Unit	Test 1	
Downlink power allocation	$\rho_A$	dB	0
	$\rho_B$	dB	0 (Note 1)
	$\sigma$	dB	-3
Cell-specific reference signals		Antenna ports 0 and 1	
CSI reference signals		Antenna ports 15,16	
DMRS ports (dual layer transmission)		port 7 and port 8	
Beamforming model		Annex B.4.2	
CSI-RS periodicity and subframe offset $T_{\text{CSI-RS}} / \Delta_{\text{CSI-RS}}$	Subframes	5/2	
CSI reference signal configuration		8	
Zero-power CSI-RS configuration $I_{\text{CSI-RS}} / \text{ZeroPowerCSI-RS}$ bitmap	Subframes / bitmap	3 / 0010000000000000	
$N_{oc}$ at antenna port	dBm/15kHz	-98	
Symbols for unused PRBs		OCNG (Note 2)	
PDSCH transmission mode		9	
DL Burst transmission pattern for LAA SCell		As specified in B.8	
The number of subframes set ( $S_r$ ) in a burst		{1,3,5,8}	
Occupied OFDM symbols set in the last subframe		{6,9,12,14}	
Random variable $p$ defined in B.8		0.5	
timing error relative of LAA SCell to PCell	$\mu\text{s}$	0	
Frequency offset of the $i$ -th LAA SCell relative to PCell	Hz	200	
Note 1: $P_B = 1$			
Note 2: These physical resource blocks are assigned only within burst transmissions to a LAA UE; the data transmitted over the OCNG PDSCHs shall be uncorrelated pseudo random data, which is QPSK modulated.			

**Table 8.3.3.1.1-5: Single carrier performance Large Delay CDD (FRC) for PCell for multiple CA configurations**

Bandwidth	Reference channel	OCNG pattern	Propagation condition	Correlation matrix and antenna config.	Reference value	
					Fraction of Nominal maximum throughput (%)	SNR (dB)
1.4MHz	R.11-5 FDD	OP.1 FDD	EVA70	2x2 Low	70	13.6
3MHz	R.11-6 FDD	OP.1 FDD	EVA70	2x2 Low	70	12.3
5MHz	R.11-2 FDD	OP.1 FDD	EVA70	2x2 Low	70	12.3
10MHz	R.11 FDD	OP.1 FDD	EVA70	2x2 Low	70	12.9
15MHz	R.11-7 FDD	OP.1 FDD	EVA70	2x2 Low	70	12.8
20MHz	R.30 FDD	OP.1 FDD	EVA70	2x2 Low	70	12.9

**Table 8.3.3.1.1-6: Single carrier performance for CDM-multiplexed DM RS (dual layer) for LAA SCell for multiple CA configurations**

Bandwidth	Sub-test (Note 2)	Reference channel	OCNG pattern	Propagation condition	Correlation matrix and antenna config.	Reference value	
						Fraction of maximum throughput (%) (Note 1)	SNR (dB)
20MHz	1	R.2 FS3	OP.1 FS3	EVA5	2x2 Low	70	14.1
	2	R.2 FS3	OP.1 FS3	EVA5	2x2 Low	70	14
	3	R.2 FS3	OP.1 FS3	EVA5	2x2 Low	70	14.2
	4	R.2 FS3	OP.1 FS3	EVA5	2x2 Low	70	14.2
Note 1: Fraction of nominal maximum throughput is calculated based on random occasions of LAA PDSCCH transmission.							
Note 2: An UE is required to fulfill only one test of Sub-test 1-4 depending on UE capabilities of endingDwPTS and secondSlotStartingPosition. For an UE not supporting both endingDwPTS and secondSlotStartingPosition, it is required to fulfill Sub-test 1; For an UE not supporting endingDwPTS but supporting secondSlotStartingPosition, it is required to fulfill Sub-test 2; For an UE supporting endingDwPTS but not supporting secondSlotStartingPosition, it is required to fulfill Sub-test 3; and For an UE supporting both endingDwPTS and secondSlotStartingPosition, it is required to fulfill Sub-test 4.							

**Table 8.3.3.1.1-7: Minimum performance (FRC) based on single carrier performance for CA with one LAA SCell**

Test number	Aggregated Bandwidth (MHz)			Minimum performance requirement (Note 2)	UE Category
	Total	PCell	LAA SCell		
1	2x20	20	20	As defined in Table 8.3.3.1.1-5 and Table 8.3.3.1.1-6	≥5
2	15+20	15	20	As defined in Table 8.3.3.1.1-5 and Table 8.3.3.1.1-6	≥5
3	10+20	10	20	As defined in Table 8.3.3.1.1-5 and Table 8.3.3.1.1-6	≥5
Note 1: The applicability of requirements for different CA configurations and bandwidth combination sets is defined in 8.1.2.3D.					
Note 2: Apply a per-CC requirement defined in Table 8.3.3.1.1-5 for PCell and apply a per-CC requirement defined in Table 8.3.3.1.1-6 for LAA SCell.					

**Table 8.3.3.1.1-8: Minimum performance (FRC) based on single carrier performance for CA with two LAA SCells**

Test number	Aggregated Bandwidth (MHz)			Minimum performance requirement (Note 2)	UE Category
	Total	PCell	LAA SCell		
1	3x20	20	2x20	As defined in Table 8.3.3.1.1-5 and Table 8.3.3.1.1-6	≥5
2	15+2x20	15	2x20	As defined in Table 8.3.3.1.1-5 and Table 8.3.3.1.1-6	≥5
3	10+2x20	10	2x20	As defined in Table 8.3.3.1.1-5 and Table 8.3.3.1.1-6	≥5
Note 1:	The applicability of requirements for different CA configurations and bandwidth combination sets is defined in 8.1.2.3D.				
Note 2:	Apply a per-CC requirement defined in Table 8.3.3.1.1-5 for PCell and apply a per-CC requirement defined in Table 8.3.3.1.1-6 for LAA SCell.				

**Table 8.3.3.1.1-9: Minimum performance (FRC) based on single carrier performance for CA with three LAA SCells**

Test number	Aggregated Bandwidth (MHz)			Minimum performance requirement (Note 2)	UE Category
	Total	PCell	LAA SCell		
1	4x20	20	3x20	As defined in Table 8.3.3.1.1-5 and Table 8.3.3.1.1-6	≥5
2	15+3x20	15	3x20	As defined in Table 8.3.3.1.1-5 and Table 8.3.3.1.1-6	≥5
3	10+3x20	10	3x20	As defined in Table 8.3.3.1.1-5 and Table 8.3.3.1.1-6	≥5
Note 1:	The applicability of requirements for different CA configurations and bandwidth combination sets is defined in 8.1.2.3D.				
Note 2:	Apply a per-CC requirement defined in Table 8.3.3.1.1-5 for PCell and apply a per-CC requirement defined in Table 8.3.3.1.1-6 for LAA SCell.				

**Table 8.3.3.1.1-10: Minimum performance (FRC) based on single carrier performance for CA with four LAA SCells**

Test number	Aggregated Bandwidth (MHz)			Minimum performance requirement (Note 2)	UE Category
	Total	PCell	LAA SCell		
1	5x20	20	4x20	As defined in Table 8.3.3.1.1-5 and Table 8.3.3.1.1-6	≥5
2	15+4x20	15	4x20	As defined in Table 8.3.3.1.1-5 and Table 8.3.3.1.1-6	≥5
3	10+4x20	10	4x20	As defined in Table 8.3.3.1.1-5 and Table 8.3.3.1.1-6	≥5
Note 1:	The applicability of requirements for different CA configurations and bandwidth combination sets is defined in 8.1.2.3D.				
Note 2:	Apply a per-CC requirement defined in Table 8.3.3.1.1-5 for PCell and apply a per-CC requirement defined in Table 8.3.3.1.1-6 for LAA SCell.				

**Table 8.3.3.1.1-11: Minimum performance (FRC) based on single carrier performance for CA with five LAA SCells**

Test number	Aggregated Bandwidth (MHz)			Minimum performance requirement (Note 2)	UE Category
	Total	PCell	LAA SCell		
1	6x20	20	5x20	As defined in Table 8.3.3.1.1-5 and Table 8.3.3.1.1-6	≥5
2	15+5x20	15	5x20	As defined in Table 8.3.3.1.1-5 and Table 8.3.3.1.1-6	≥5
3	10+5x20	10	5x20	As defined in Table 8.3.3.1.1-5 and Table 8.3.3.1.1-6	≥5
Note 1:	The applicability of requirements for different CA configurations and bandwidth combination sets is defined in 8.1.2.3D.				
Note 2:	Apply a per-CC requirement defined in Table 8.3.3.1.1-5 for PCell and apply a per-CC requirement defined in Table 8.3.3.1.1-6 for LAA SCell.				

**Table 8.3.3.1.1-12: Minimum performance (FRC) based on single carrier performance for CA with six LAA SCells**

Test number	Aggregated Bandwidth (MHz)			Minimum performance requirement (Note 2)	UE Category
	Total	PCell	LAA SCell		
1	7x20	20	6x20	As defined in Table 8.3.3.1.1-5 and Table 8.3.3.1.1-6	≥5
2	15+6x20	15	6x20	As defined in Table 8.3.3.1.1-5 and Table 8.3.3.1.1-6	≥5
3	10+6x20	10	6x20	As defined in Table 8.3.3.1.1-5 and Table 8.3.3.1.1-6	≥5
Note 1:	The applicability of requirements for different CA configurations and bandwidth combination sets is defined in 8.1.2.3D.				
Note 2:	Apply a per-CC requirement defined in Table 8.3.3.1.1-5 for PCell and apply a per-CC requirement defined in Table 8.3.3.1.1-6 for LAA SCell.				

**8.3.3.1.2 TDD Pcell (TDD single carrier)**

The parameters specified in Table 8.3.3.1.2-1 are valid for TDD CC and LAA SCell(s) unless otherwise stated. And the additional parameters specified in Table 8.3.3.1.2-2 are valid for LAA SCell(s).

**Table 8.3.3.1.2-1: Common Test Parameters**

Parameter	Unit	Value
Uplink downlink configuration (Note 1)		1
Special subframe configuration (Note 2)		4
Cyclic prefix		Normal
Cell ID		0
Inter-TTI Distance		1
Number of HARQ processes	Processes	7
Maximum number of HARQ transmission (Note 3)		4
Redundancy version coding sequence		{0,1,2,3} for QPSK and 16QAM {0,0,1,2} for 64QAM and 256QAM
Precoder update granularity		Frequency domain: 1 PRG for Transmission modes 9 Time domain: 1 ms
ACK/NACK feedback mode		Multiplexing
Note 1:	As specified in Table 4.2-2 in TS 36.211 [4]	
Note 2:	As specified in Table 4.2-1 in TS 36.211 [4]	
Note 3:	For retransmission in partial subframes, the TB size should be kept the same as the initial transmission regardless of the initial transmission is performed in full subframes or partial subframes.	

**Table 8.3.3.1.2-2: Additional Test Parameters for LAA SCell(s)**

Parameter	Unit	Value
DMTC Periodicity	ms	80
dmtc-PeriodOffset-r12 ms80-r12		0
Discovery signal occasion duration	subframe	1
Power allocation of discovery signal		Same as power allocation of CRS within a transmission burst in the test

For CA with LAA SCell(s), the requirements for dual-layer transmission on antenna ports 7 and 8 upon detection of a PDCCH with DCI format 2C are specified in Table 8.3.3.1.2-7, with the addition of the parameters in Table 8.3.3.1.2-3, Table 8.3.3.1.2-4 and Table 8.3.3.1.2-5. The downlink physical channel setup is set according to Annex C.3.2. The purpose of these tests is to verify the rank-2 performance for full RB allocation for CA with LAA SCell(s).

**Table 8.3.3.1.2-3: Test Parameters for Large Delay CDD (FRC) for PCell**

Parameter	Unit	Value
Downlink power allocation	$\rho_A$	-3
	$\rho_B$	-3 (NOTE 1)
	$\sigma$	0
$N_{oc}$ at antenna port	dBm/15kHz	-98
PDSCH transmission mode		TM3
Subframe configuration		Non-MBSFN
NOTE 1: $P_B = 1$ .		
NOTE 2: PUCCH format 3 is used to feedback ACK/NACK.		
NOTE 3: Void.		

Table 8.3.3.1.2-4: Test Parameters for CDM-multiplexed DM RS (dual layer) for LAA SCell(s)

Parameter		Unit	Test 1
Downlink power allocation	$\rho_A$	dB	0
	$\rho_B$	dB	0 (Note 1)
	$\sigma$	dB	-3
Cell-specific reference signals			Antenna ports 0 and 1
CSI reference signals			Antenna ports 15,16
DMRS ports (dual layer transmission)			port 7 and port 8
Beamforming model			Annex B.4.2
CSI-RS periodicity and subframe offset $T_{\text{CSI-RS}} / \Delta_{\text{CSI-RS}}$	Subframes		5/4
CSI reference signal configuration			8
Zero-power CSI-RS configuration $I_{\text{CSI-RS}} / \text{ZeroPowerCSI-RS}$ bitmap	Subframes / bitmap		4/ 0010000000000000
$N_{oc}$ at antenna port	dBm/15kHz		-98
Symbols for unused PRBs			OCNG (Note 2)
PDSCH transmission mode			9
DL Burst transmission pattern for LAA SCell			As specified in B.8
The number of subframes set ( $S_i$ ) in a burst			{1,3,5,8}
Occupied OFDM symbols set in the last subframe			{6,9,12,14}
Random variable $p$ defined in B.8			0.5
Timing error relative of LAA SCell to PCell		$\mu\text{s}$	0
Frequency offset of th $i$ -th LAA SCell relative to PCell		Hz	200
Note 1: $P_B = 1$			
Note 2: These physical resource blocks are assigned only within burst transmissions to a LAA UE; the data transmitted over the OCNG PDSCHs shall be uncorrelated pseudo random data, which is QPSK modulated.			



**Table 8.3.3.1.2-5: Single carrier performance Large Delay CDD (FRC) for PCell for multiple CA configurations**

Bandwidth	Reference channel	OCNG pattern	Propagation condition	Correlation matrix and antenna config.	Reference value	
					Fraction of maximum throughput (%)	SNR (dB)
1.4MHz	R.11-5 TDD	OP.1 TDD	EVA70	2x2 Low	70	13.2
3MHz	R.11-6 TDD	OP.1 TDD	EVA70	2x2 Low	70	12.8
5MHz	R.11-7 TDD	OP.1 TDD	EVA70	2x2 Low	70	12.6
10MHz	R.11-8 TDD	OP.1 TDD	EVA70	2x2 Low	70	12.8
15MHz	R.11-9 TDD	OP.1 TDD	EVA70	2x2 Low	70	12.9
20MHz	R.30-1 TDD	OP.1 TDD	EVA70	2x2 Low	70	13.0

**Table 8.3.3.1.2-6: Single carrier performance for CDM-multiplexed DM RS (dual layer) for LAA SCell(s) for multiple CA configurations**

Bandwidth	Sub-test (Note2)	Reference channel	OCNG pattern	Propagation condition	Correlation matrix and antenna config.	Reference value	
						Fraction of Nominal maximum throughput (%) (Note 1)	SNR (dB)
20MHz	1	R.2 FS3	OP.1 FS3	EVA5	2x2 Low	70	14.1
	2	R.2 FS3	OP.1 FS3	EVA5	2x2 Low	70	14
	3	R.2 FS3	OP.1 FS3	EVA5	2x2 Low	70	14.2
	4	R.2 FS3	OP.1 FS3	EVA5	2x2 Low	70	14.2

Note 1: Fraction of nominal maximum throughput is calculated based on random occasions of LAA PDSCCH transmission.

Note 2: An UE is required to fulfill only one test of Sub-test 1-4 depending on UE capabilities of endingDwPTS and secondSlotStartingPosition. For an UE not supporting both endingDwPTS and secondSlotStartingPosition, it is required to fulfill Sub-test 1; For an UE not supporting endingDwPTS but supporting secondSlotStartingPosition, it is required to fulfill Sub-test 2; For an UE supporting endingDwPTS but not supporting secondSlotStartingPosition, it is required to fulfill Sub-test 3; and For an UE supporting both endingDwPTS and secondSlotStartingPosition, it is required to fulfill Sub-test 4.

**Table 8.3.3.1.2-7: Minimum performance (FRC) based on single carrier performance for CA with one LAA SCell**

Test number	Aggregated Bandwidth (MHz)			Minimum performance requirement (Note 2)	UE Category
	Total	PCell	LAA SCell		
1	2x20	20	20	As defined in Table 8.3.3.1.2-5 and Table 8.3.3.1.2-6	≥5

Note 1: The applicability of requirements for different CA configurations and bandwidth combination sets is defined in 8.1.2.3D.

Note 2: Apply a per-CC requirement defined in Table 8.3.3.1.2-5 for PCell and apply a per-CC requirement defined in Table 8.3.3.1.2-6 for LAA SCell.

**Table 8.3.3.1.2-8: Minimum performance (FRC) based on single carrier performance for CA with two LAA SCells**

Test number	Aggregated Bandwidth (MHz)			Minimum performance requirement (Note 2)	UE Category
	Total	PCell	LAA SCell		
1	3x20	20	2x20	As defined in Table 8.3.3.1.2-5 and Table 8.3.3.1.2-6	≥5

Note 1: The applicability of requirements for different CA configurations and bandwidth combination sets is defined in 8.1.2.3D.

Note 2: Apply a per-CC requirement defined in Table 8.3.3.1.2-5 for PCell and apply a per-CC requirement defined in Table 8.3.3.1.2-6 for LAA SCell.

**Table 8.3.3.1.2-9: Minimum performance (FRC) based on single carrier performance for CA with three LAA SCells**

Test number	Aggregated Bandwidth (MHz)			Minimum performance requirement (Note 2)	UE Category
	Total	PCell	LAA SCell		
1	4x20	20	3x20	As defined in Table 8.3.3.1.2-5 and Table 8.3.3.1.2-6	≥5
Note 1:	The applicability of requirements for different CA configurations and bandwidth combination sets is defined in 8.1.2.3D.				
Note 2:	Apply a per-CC requirement defined in Table 8.3.3.1.2-5 for PCell and apply a per-CC requirement defined in Table 8.3.3.1.2-6 for LAA SCell.				

**Table 8.3.3.1.2-10: Minimum performance (FRC) based on single carrier performance for CA with four LAA SCells**

Test number	Aggregated Bandwidth (MHz)			Minimum performance requirement (Note 2)	UE Category
	Total	PCell	LAA SCell		
1	5x20	20	4x20	As defined in Table 8.3.3.1.2-5 and Table 8.3.3.1.2-6	≥5
Note 1:	The applicability of requirements for different CA configurations and bandwidth combination sets is defined in 8.1.2.3D.				
Note 2:	Apply a per-CC requirement defined in Table 8.3.3.1.2-5 for PCell and apply a per-CC requirement defined in Table 8.3.3.1.2-6 for LAA SCell.				

**Table 8.3.3.1.2-11: Minimum performance (FRC) based on single carrier performance for CA with five LAA SCells**

Test number	Aggregated Bandwidth (MHz)			Minimum performance requirement (Note 2)	UE Category
	Total	PCell	LAA SCell		
1	6x20	20	5x20	As defined in Table 8.3.3.1.2-5 and Table 8.3.3.1.2-6	≥5
Note 1:	The applicability of requirements for different CA configurations and bandwidth combination sets is defined in 8.1.2.3D.				
Note 2:	Apply a per-CC requirement defined in Table 8.3.3.1.2-5 for PCell and apply a per-CC requirement defined in Table 8.3.3.1.2-6 for LAA SCell.				

**Table 8.3.3.1.2-12: Minimum performance (FRC) based on single carrier performance for CA with six LAA SCells**

Test number	Aggregated Bandwidth (MHz)			Minimum performance requirement (Note 2)	UE Category
	Total	PCell	LAA SCell		
1	7x20	20	6x20	As defined in Table 8.3.3.1.2-5 and Table 8.3.3.1.2-6	≥5
Note 1:	The applicability of requirements for different CA configurations and bandwidth combination sets is defined in 8.1.2.3D.				
Note 2:	Apply a per-CC requirement defined in Table 8.3.3.1.2-5 for PCell and apply a per-CC requirement defined in Table 8.3.3.1.2-6 for LAA SCell.				

## 8.4 Demodulation of PDCCH/PCFICH

The receiver characteristics of the PDCCH/PCFICH are determined by the probability of miss-detection of the Downlink Scheduling Grant (Pm-dsg). PDCCH and PCFICH are tested jointly, i.e. a miss detection of PCFICH implies a miss detection of PDCCH.

### 8.4.1 FDD

The parameters specified in Table 8.4.1-1 are valid for all FDD tests unless otherwise stated.

**Table 8.4.1-1: Test Parameters for PDCCH/PCFICH**

Parameter		Unit	Single antenna port	Transmit diversity
Number of PDCCH symbols		symbols	2	2
PHICH Ng (Note 1)			1	1
PHICH duration			Normal	Normal
Unused RE-s and PRB-s			OCNG	OCNG
Cell ID			0	0
Downlink power allocation	PDCCH_RA PHICH_RA OCNG_RA	dB	0	-3
	PCFICH_RB PDCCH_RB PHICH_RB OCNG_RB	dB	0	-3
$N_{oc}$ at antenna port		dBm/15kHz	-98	-98
Cyclic prefix			Normal	Normal
Note 1: According to Clause 6.9 in TS 36.211 [4]				

#### 8.4.1.1 Single-antenna port performance

For the parameters specified in Table 8.4.1-1 the average probability of a missed downlink scheduling grant (Pm-dsg) shall be below the specified value in Table 8.4.1.1-1. The downlink physical setup is in accordance with Annex C.3.2.

**Table 8.4.1.1-1: Minimum performance PDCCH/PCFICH**

Test number	Bandwidth	Aggregation level	Reference Channel	OCNG Pattern	Propagation Condition	Antenna configuration and correlation Matrix	Reference value	
							Pm-dsg (%)	SNR (dB)
1	10 MHz	8 CCE	R.15 FDD	OP.1 FDD	ETU70	1x2 Low	1	-1.7

#### 8.4.1.2 Transmit diversity performance

##### 8.4.1.2.1 Minimum Requirement 2 Tx Antenna Port

For the parameters specified in Table 8.4.1-1 the average probability of a missed downlink scheduling grant (Pm-dsg) shall be below the specified value in Table 8.4.1.2.1-1. The downlink physical setup is in accordance with Annex C.3.2.

**Table 8.4.1.2.1-1: Minimum performance PDCCH/PCFICH**

Test number	Bandwidth	Aggregation level	Reference Channel	OCNG Pattern	Propagation Condition	Antenna configuration and correlation Matrix	Reference value	
							Pm-dsg (%)	SNR (dB)
1	10 MHz	4 CCE	R.16 FDD	OP.1 FDD	EVA70	2 x 2 Low	1	-0.6

##### 8.4.1.2.2 Minimum Requirement 4 Tx Antenna Port

For the parameters specified in Table 8.4.1-1 the average probability of a missed downlink scheduling grant (Pm-dsg) shall be below the specified value in Table 8.4.1.2.2-1. The downlink physical setup is in accordance with Annex C.3.2.

**Table 8.4.1.2.2-1: Minimum performance PDCCH/PCFICH**

Test number	Bandwidth	Aggregation level	Reference Channel	OCNG Pattern	Propagation Condition	Antenna configuration and correlation Matrix	Reference value	
							Pm-dsg (%)	SNR (dB)
1	5 MHz	2 CCE	R.17 FDD	OP.1 FDD	EPA5	4 x 2 Medium	1	6.3

#### 8.4.1.2.3 Minimum Requirement 2 Tx Antenna Port (demodulation subframe overlaps with aggressor cell ABS)

For the parameters for non-MBSFN ABS specified in Table 8.4.1-1 and Table 8.4.1.2.3-1, the average probability of a missed downlink scheduling grant (Pm-dsg) shall be below the specified value in Table 8.4.1.2.3-2. The downlink physical setup is in accordance with Annex C.3.2 and Annex C.3.3. In Table 8.4.1.2.3-1, Cell 1 is the serving cell, and Cell 2 is the aggressor cell. The downlink physical channel setup for Cell 1 is according to Annex C.3.2 and for Cell 2 is according to Annex C.3.3, respectively.

For the parameters for MBSFN ABS specified in Table 8.4.1-1 and Table 8.4.1.2.3-3, the average probability of a missed downlink scheduling grant (Pm-dsg) shall be below the specified value in Table 8.4.1.2.3-4. The downlink physical channel setup for Cell 1 is according to Annex C.3.2 and for Cell 2 is according to Annex C.3.3, respectively.

Table 8.4.1.2.3-1: Test Parameters for PDCCH/PCFICH – Non-MBSFN ABS

Parameter		Unit	Cell 1	Cell 2
Downlink power allocation	PDCCH_RA PHICH_RA OCNG_RA	dB	-3	-3
	PCFICH_RB PDCCH_RB PHICH_RB OCNG_RB	dB	-3	-3
$N_{oc}$ at antenna port	$N_{oc1}$	dBm/15kHz	-100.5 (Note 1)	N/A
	$N_{oc2}$	dBm/15kHz	-98 (Note 2)	N/A
	$N_{oc3}$	dBm/15kHz	-95.3 (Note 3)	N/A
$E_s/N_{oc2}$		dB	Reference Value in Table 8.4.1.2.3-2	1.5
BW <sub>Channel</sub>		MHz	10	10
Subframe Configuration			Non-MBSFN	Non-MBSFN
Time Offset between Cells		μs	2.5 (synchronous cells)	
Cell Id			0	1
ABS pattern (Note 4)			N/A	00000100 00000100 00000100 01000100 00000100
RLM/RRM Measurement Subframe Pattern (Note 5)			00000100 00000100 00000100 00000100 00000100	N/A
CSI Subframe Sets (Note 6)	$C_{CSI,0}$		00000100 00000100 00000100 01000100 00000100	N/A
	$C_{CSI,1}$		11111011 11111011 11111011 10111011 11111011	N/A
Number of control OFDM symbols			3	3
PHICH Ng (Note 9)			1	N/A
PHICH duration			Extended	N/A
Unused RE-s and PRB-s			OCNG	OCNG
Cyclic prefix			Normal	Normal
<p>Note 1: This noise is applied in OFDM symbols #1, #2, #3, #5, #6, #8, #9, #10, #12, #13 of a subframe overlapping with the aggressor ABS.</p> <p>Note 2: This noise is applied in OFDM symbols #0, #4, #7, #11 of a subframe overlapping with the aggressor ABS.</p> <p>Note 3: This noise is applied in all OFDM symbols of a subframe overlapping with aggressor non-ABS</p> <p>Note 4: ABS pattern as defined in [9]. PDCCH/PCFICH other than that associated with SIB1/Paging are transmitted in the serving cell subframe when the subframe is overlapped with the ABS subframe of aggressor cell.</p> <p>Note 5: Time-domain measurement resource restriction pattern for PCell measurements as defined in [7];</p> <p>Note 6: As configured according to the time-domain measurement resource restriction pattern for CSI measurements defined in [7];</p> <p>Note 7: Cell 1 is the serving cell. Cell 2 is the aggressor cell. The number of the CRS ports in Cell1 and Cell2 is the same.</p> <p>Note 8: SIB-1 will not be transmitted in Cell2 in the test.</p> <p>Note 9: According to Clause 6.9 in TS 36.211 [4]</p>				

Table 8.4.1.2.3-2: Minimum performance PDCCH/PCFICH – Non-MBSFN ABS

Test Number	Aggregation Level	Reference Channel	OCNG Pattern		Propagation Conditions (Note 1)		Correlation Matrix and Antenna Configuration	Reference Value	
			Cell 1	Cell 2	Cell 1	Cell 2		Pm-dsg (%)	SNR (dB) (Note 2)
1	8 CCE	R15-1 FDD	OP.1 FDD	OP.1 FDD	EVA5	EVA5	2x2 Low	1	-3.9
<p>Note 1: The propagation conditions for Cell 1 and Cell 2 are statistically independent.</p> <p>Note 2: SNR corresponds to <math>E_s/N_{oc2}</math> of cell 1.</p> <p>Note 3: The correlation matrix and antenna configuration apply for Cell 1 and Cell 2.</p>									

**Table 8.4.1.2.3-3: Test Parameters for PDCCH/PCFICH – MBSFN ABS**

Parameter		Unit	Cell 1	Cell 2
Downlink power allocation	PDCCH_RA PHICH_RA OCNG_RA	dB	-3	-3
	PCFICH_RB PDCCH_RB PHICH_RB OCNG_RB	dB	-3	-3
$N_{oc}$ at antenna port	$N_{oc1}$	dBm/15kHz	-100.5 (Note 1)	N/A
	$N_{oc2}$	dBm/15kHz	-98 (Note 2)	N/A
	$N_{oc3}$	dBm/15kHz	-95.3 (Note 3)	N/A
$E_s/N_{oc2}$		dB	Reference Value in Table 8.4.1.2.3-4	1.5
$BW_{Channel}$		MHz	10	10
Subframe Configuration			Non-MBSFN	MBSFN
Time Offset between Cells		$\mu$ s	2.5 (synchronous cells)	
Cell Id			0	126
ABS pattern (Note 4)			N/A	0001000000 0100000010 0000001000 0000000000
RLM/RRM Measurement Subframe Pattern (Note 5)			0001000000 0100000010 0000001000 0000000000	N/A
CSI Subframe Sets (Note 6)	$C_{csi,0}$		0001000000 0100000010 0000001000 0000000000	N/A
	$C_{csi,1}$		1110111111 1011111101 1111110111 1111111111	N/A
MBSFN Subframe Allocation (Note 9)			N/A	001000 100001 000100 000000
Number of control OFDM symbols			3	3
PHICH Ng (Note 11)			1	N/A
PHICH duration			extended	N/A
Unused RE-s and PRB-s			OCNG	OCNG
Cyclic prefix			Normal	Normal



Note 1:	This noise is applied in OFDM symbols #1, #2, #3, #4, #5, #6, #7, #8, #9, #10, #11, #12, #13 of a subframe overlapping with the aggressor ABS.
Note 2:	This noise is applied in OFDM symbols #0 of a subframe overlapping with the aggressor ABS.
Note 3:	This noise is applied in all OFDM symbols of a subframe overlapping with aggressor non-ABS
Note 4:	ABS pattern as defined in [9]. The 4 <sup>th</sup> , 12 <sup>th</sup> , 19 <sup>th</sup> and 27 <sup>th</sup> subframes indicated by ABS pattern are MBSFN ABS subframes. PDSCH other than SIB1/paging and its associated PDCCH/PCFICH are transmitted in the serving cell subframe when the subframe is overlapped with the MBSFN ABS subframe of aggressor cell and the subframe is available in the definition of the reference channel.
Note 5:	Time-domain measurement resource restriction pattern for PCell measurements as defined in [7].
Note 6:	As configured according to the time-domain measurement resource restriction pattern for CSI measurements defined in [7].
Note 7:	Cell 1 is the serving cell. Cell 2 is the aggressor cell. The number of the CRS ports in Cell1 and Cell2 is the same.
Note 8:	SIB-1 will not be transmitted in Cell2 in this test.
Note 9:	MBSFN Subframe Allocation as defined in [7], four frames with 24 bits is chosen for MBSFN subframe allocation.
Note 10:	The maximum number of uplink HARQ transmission is $\leq 2$ so that each PHICH channel transmission is in a subframe protected by MBSFN ABS in this test.
Note 11:	According to Clause 6.9 in TS 36.211 [4]

Table 8.4.1.2.3-4: Minimum performance PDCCH/PCHICH – MBSFN ABS

Test Number	Aggregation Level	Reference Channel	OCNG Pattern		Propagation Conditions (Note 1)		Correlation Matrix and Antenna Configuration	Reference Value	
			Cell 1	Cell 2	Cell 1	Cell 2		Pm-dsg (%)	SNR (dB) (Note 2)
1	8 CCE	R15-1 FDD	OP.1 FDD	OP.1 FDD	EVA5	EVA5	2x2 Low	1	-4.2
Note 1: The propagation conditions for Cell 1 and Cell2 are statistically independent.									
Note 2: SNR corresponds to $E_s/N_{oc2}$ of cell 1.									
Note 3: The correlation matrix and antenna configuration apply for Cell 1 and Cell 2.									

#### 8.4.1.2.4 Minimum Requirement 2 Tx Antenna Port (demodulation subframe overlaps with aggressor cell ABS and CRS assistance information are configured)

For the parameters for non-MBSFN ABS specified in Table 8.4.1-1 and Table 8.4.1.2.4-1, the average probability of a missed downlink scheduling grant (Pm-dsg) shall be below the specified value in Table 8.4.1.2.4-2.

For the parameters for MBSFN ABS specified in Table 8.4.1-1 and Table 8.4.1.2.4-3, the average probability of a missed downlink scheduling grant (Pm-dsg) shall be below the specified value in Table 8.4.1.2.4-4.

In Tables 8.4.1.2.4-1 and 8.4.1.2.4-3, Cell 1 is the serving cell, and Cell 2 and Cell3 are the aggressor cells. The downlink physical channel setup for Cell 1 is according to Annex C.3.2 and for Cell 2 and Cell 3 is according to Annex C.3.3, respectively. The CRS assistance information [7] including Cell 2 and Cell 3 is provided.

**Table 8.4.1.2.4-1: Test Parameters for PDCCH/PCFICH – Non-MBSFN ABS**

Parameter		Unit	Cell 1	Cell 2	Cell 3
Downlink power allocation	PDCCH_RA PHICH_RA OCNG_RA	dB	-3	-3	-3
	PCFICH_RB PDCCH_RB PHICH_RB OCNG_RB	dB	-3	-3	-3
$N_{oc}$ at antenna port	$N_{oc1}$	dBm/15kHz	-98(Note 1)	N/A	N/A
	$N_{oc2}$	dBm/15kHz	-98 (Note 2)	N/A	N/A
	$N_{oc3}$	dBm/15kHz	-93 (Note 3)	N/A	N/A
$\bar{E}_s/N_{oc2}$		dB	Reference Value in Table 8.4.1.2.4-2	5	3
BW <sub>Channel</sub>		MHz	10	10	10
Subframe Configuration			Non-MBSFN	Non-MBSFN	Non-MBSFN
Time Offset between Cells		μs	N/A	3	-1
Frequency shift between Cells		Hz	N/A	300	-100
Cell Id			0	126	1
ABS pattern (Note 4)			N/A	00000100 00000100 00000100 00000100 00000100	00000100 00000100 00000100 00000100 00000100
RLM/RRM Measurement Subframe Pattern (Note 5)			00000100 00000100 00000100 00000100 00000100	N/A	N/A
CSI Subframe Sets (Note 6)	$C_{CSI,0}$		00000100 00000100 00000100 00000100 00000100	N/A	N/A
	$C_{CSI,1}$		11111011 11111011 11111011 11111011 11111011	N/A	N/A
Number of control OFDM symbols			2	Note 7	Note 7
PHICH Ng (Note 10)			1	N/A	N/A
PHICH duration			Normal	N/A	N/A
Unused RE-s and PRB-s			OCNG	OCNG	OCNG
Cyclic prefix			Normal	Normal	Normal
<p>Note 1: This noise is applied in OFDM symbols #1, #2, #3, #5, #6, #8, #9, #10, #12, #13 of a subframe overlapping with the aggressor ABS.</p> <p>Note 2: This noise is applied in OFDM symbols #0, #4, #7, #11 of a subframe overlapping with the aggressor ABS.</p> <p>Note 3: This noise is applied in all OFDM symbols of a subframe overlapping with aggressor non-ABS.</p> <p>Note 4: ABS pattern as defined in [9]. PDCCH/PCFICH other than that associated with SIB1/Paging are transmitted in the serving cell subframe when the subframe is overlapped with the ABS subframe of aggressor cell.</p> <p>Note 5: Time-domain measurement resource restriction pattern for PCell measurements as defined in [7].</p> <p>Note 6: As configured according to the time-domain measurement resource restriction pattern for CSI measurements defined in [7].</p> <p>Note 7: The number of control OFDM symbols is not available for ABS and is 2 for the subframe indicated by "0" of ABS pattern.</p> <p>Note 8: The number of the CRS ports in Cell1, Cell2 and Cell 3is the same.</p> <p>Note 9: SIB-1 will not be transmitted in Cell2 and Cell 3 in the test.</p> <p>Note 10: According to Clause 6.9 in TS 36.211 [4]</p>					

Table 8.4.1.2.4-2: Minimum performance PDCCH/PCFICH – Non-MBSFN ABS

Test Number	Aggregation Level	Reference Channel	OCNG Pattern			Propagation Conditions (Note 1)			Correlation Matrix and Antenna Configuration (Note 2)	Reference Value	
			Cell 1	Cell 2	Cell 3	Cell 1	Cell 2	Cell3		Pm-dsg (%)	SNR (dB) (Note 3)
1	8 CCE	R.15-2 FDD	OP.1 FDD	OP.1 FDD	OP.1 FDD	EVA5	EVA5	EVA5	2x2 Low	1	-2.2
<p>Note 1: The propagation conditions for Cell 1, Cell 2 and Cell 3 are statistically independent.</p> <p>Note 2: The correlation matrix and antenna configuration apply for Cell 1, Cell 2 and Cell 3.</p> <p>Note 3: SNR corresponds to <math>\hat{E}_s / N_{oc2}</math> of cell 1.</p>											

**Table 8.4.1.2.4-3: Test Parameters for PDCCH/PCFICH – MBSFN ABS**

Parameter		Unit	Cell 1	Cell 2	Cell 3
Downlink power allocation	PDCCH_RA PHICH_RA OCNG_RA	dB	-3	-3	-3
	PCFICH_RB PDCCH_RB PHICH_RB OCNG_RB	dB	-3	-3	-3
$N_{oc}$ at antenna port	$N_{oc1}$	dBm/15kHz	-98(Note 1)	N/A	N/A
	$N_{oc2}$	dBm/15kHz	-98 (Note 2)	N/A	N/A
	$N_{oc3}$	dBm/15kHz	-93 (Note 3)	N/A	N/A
$\bar{E}_s/N_{oc2}$		dB	Reference Value in Table 8.4.1.2.4-4	5	3
$BW_{channel}$		MHz	10	10	10
Subframe Configuration			Non-MBSFN	MBSFN	MBSFN
Time Offset between Cells		$\mu$ s	N/A	3	-1
Frequency shift between Cells		Hz	N/A	300	-100
Cell Id			0	126	1
ABS pattern (Note 4)			N/A	0001000000 0100000010 0000001000 0000000000	0001000000 0100000010 0000001000 0000000000
RLM/RRM Measurement Subframe Pattern (Note 5)			0001000000 0100000010 0000001000 0000000000	N/A	N/A
CSI Subframe Sets (Note 6)	$C_{CSI,0}$		0001000000 0100000010 0000001000 0000000000	N/A	N/A
	$C_{CSI,1}$		1110111111 1011111101 1111110111 1111111111	N/A	N/A
MBSFN Subframe Allocation (Note 7)			N/A	001000 100001 000100 000000	001000 100001 000100 000000
Number of control OFDM symbols			2	Note 8	Note 8
PHICH Ng (Note 12)			1	N/A	N/A
PHICH duration			Normal	N/A	N/A
Unused RE-s and PRB-s			OCNG	OCNG	OCNG
Cyclic prefix			Normal	Normal	Normal

Note 1:	This noise is applied in OFDM symbols #1, #2, #3, #4, #5, #6, #7, #8, #9, #10, #11, #12, #13 of a subframe overlapping with the aggressor ABS.
Note 2:	This noise is applied in OFDM symbols #0 of a subframe overlapping with the aggressor ABS.
Note 3:	This noise is applied in all OFDM symbols of a subframe overlapping with aggressor non-ABS
Note 4:	ABS pattern as defined in [9]. The 4 <sup>th</sup> , 12 <sup>th</sup> , 19 <sup>th</sup> and 27 <sup>th</sup> subframes indicated by ABS pattern are MBSFN ABS subframes. PDSCH other than SIB1/paging and its associated PDCCH/PCFICH are transmitted in the serving cell subframe when the subframe is overlapped with the MBSFN ABS subframe of aggressor cell and the subframe is available in the definition of the reference channel.
Note 5:	Time-domain measurement resource restriction pattern for PCell measurements as defined in [7].
Note 6:	As configured according to the time-domain measurement resource restriction pattern for CSI measurements defined in [7].
Note 7:	MBSFN Subframe Allocation as defined in [7], four frames with 24 bits are chosen for MBSFN subframe allocation.
Note 8:	The number of control OFDM symbols is not available for ABS and is 2 for the subframe indicated by "0" of ABS pattern.
Note 9:	The maximum number of uplink HARQ transmission is $\leq 2$ so that each PHICH channel transmission is in a subframe protected by MBSFN ABS in this test.
Note 10:	The number of the CRS ports in Cell 1, Cell 2 and Cell 3 is the same.
Note 11:	SIB-1 will not be transmitted in Cell 2 and Cell 3 in this test.
Note 12:	According to Clause 6.9 in TS 36.211 [4]

Table 8.4.1.2.4-4: Minimum performance PDCCH/PCFICH – MBSFN ABS

Test Number	Aggregation Level	Reference Channel	OCNG Pattern			Propagation Conditions (Note 1)			Correlation Matrix and Antenna Configuration (Note 2)	Reference Value	
			Cell 1	Cell 2	Cell 3	Cell 1	Cell 2	Cell 3		Pm-dsg (%)	SNR (dB) (Note 3)
1	8 CCE	R.15-2 FDD	OP.1 FDD	OP.1 FDD	OP.1 FDD	EVA5	EVA5	EVA5	2x2 Low	1	-2.0
Note 1: The propagation conditions for Cell 1, Cell 2 and Cell 3 are statistically independent.											
Note 2: The correlation matrix and antenna configuration apply for Cell 1, Cell 2 and Cell 3.											
Note 3: SNR corresponds to $\hat{E}_s / N_{oc2}$ of cell 1.											

#### 8.4.1.2.5 Enhanced Downlink Control Channel Performance Requirement Type A - 2 Tx Antenna Port under Asynchronous Network

The test purpose is to verify the Enhanced Downlink Control Channel Performance Requirement Type A for PDCCH/PCFICH with 2 transmit antennas for the case of dominant interferer with interference model defined in clause B.5.2. For the parameters specified in Table 8.4.1-1 and Table 8.4.1.2.5-1, the average probability of a missed downlink scheduling grant (Pm-dsg) shall be below the specified value in Table 8.4.1.2.5-2 for the Enhanced Downlink Control Channel Performance Requirement Type A. In Table 8.4.1.2.5-1, Cell 1 is the serving cell, and Cell 2 and Cell 3 are the aggressor cells. The downlink physical channel setup is according to Annex C.3.2 for each of Cell 1, Cell 2 and Cell 3, respectively. The CRS assistance information [7] is not provided.

Table 8.4.1.2.5-1: Test Parameters for PDCCH/PCFICH

Parameter		Unit	Cell 1	Cell 2	Cell 3
Downlink power allocation	PDCCH_RA PHICH_RA PDSCH_RA OCNG_RA	dB	-3	-3	-3
	PCFICH_RB PDCCH_RB PHICH_RB PDSCH_RB OCNG_RB	dB	-3	-3	-3
Cell-specific reference signals			Antenna ports 0,1	Antenna ports 0,1	Antenna ports 0,1
$N_{oc}$ at antenna port		dBm/15kHz	-98		
$\bar{E}_s/N_{oc}$		dB	N/A	13.91	3.34
BW <sub>Channel</sub>		MHz	10	10	10
Cyclic Prefix			Normal	Normal	Normal
Cell Id			0	1	6
Subframe Configuration			Non-MBSFN	Non-MBSFN	Non-MBSFN
Number of DL control region OFDM symbols			3	3	3
PHICH Ng (Note 1)			1	N/A	N/A
PHICH duration			Normal	N/A	N/A
PDSCH TM			4	3	3
Interference model			N/A	As specified in clause B.5.2	As specified in clause B.5.2
Probability of occurrence of PDSCH transmission rank in interfering cells	Rank 1	%	N/A	80	80
	Rank 2	%	N/A	20	20
Unused RE-s and PRB-s			OCNG	OCNG	OCNG
Time offset relative to Cell 1		ms	N/A	0.33	0.67
Frequency shift relative to Cell 1		Hz	N/A	0	0
Note 1: According to Clause 6.9 in TS 36.211 [4].					

Table 8.4.1.2.5-2: Minimum Performance for PDCCH/PCFICH for Enhanced Downlink Control Channel Performance Requirement Type A

Test Number	Aggregation level	Reference Channel	OCNG Pattern (Note 1)	Propagation Conditions (Note 2)			Antenna Configuration and Correlation Matrix (Note 3)	Reference Value	
				Cell 1	Cell 2	Cell 3		Pm-dsg (%)	SNR (dB) (Note 4)
1	2 CCE	R.16-1 FDD	OP.1 FDD	EVA70	EVA70	EVA70	2x2 Low	1	16.5
Note 1: The OCNG pattern applies for Cell 1, Cell 2 and Cell 3.									
Note 2: The propagation conditions for Cell 1, Cell 2 and Cell 3 are statistically independent.									
Note 3: The correlation matrix and antenna configuration apply for Cell 1, Cell 2 and Cell 3.									
Note 4: SNR corresponds to $\bar{E}_s/N_{oc}$ of Cell 1 as defined in clause 8.1.1.									

#### 8.4.1.2.6 Enhanced Downlink Control Channel Performance Requirement Type A - 2 Tx Antenna Port with Non-Colliding CRS Dominant Interferer

The purpose of this test is to verify the Enhanced Downlink Control Channel Performance Requirement Type A for PDCCH/PCFICH with 2 transmit antennas for the case of dominant interferer with the non-colliding CRS pattern and applying interference model defined in clause B.7.1. For the parameters specified in Table 8.4.1.1 and Table 8.4.1.2.6-1, the average probability of a missed downlink scheduling grant (Pm-dsg) shall be below the specified value in Table 8.4.1.2.6-2. In Table 8.4.1.2.6-1, Cell 1 is the serving cell, and Cell 2 and Cell 3 are the aggressor cells. The downlink



physical channel setup is according to Annex C.3.2 for each of Cell 1, Cell 2 and Cell 3, respectively. The CRS assistance information [7] is provided and includes Cell 2 and Cell 3.

**Table 8.4.1.2.6-1: Test Parameters for PDCCH/PCFICH**

Parameter		Unit	Cell 1	Cell 2	Cell 3
Downlink power allocation	PDCCH_RA OCNG_RA	dB	-3	-3	-3
	PHICH_RA	dB	-3	N/A	N/A
	PCFICH_RB PDCCH_RB OCNG_RB	dB	-3	-3	-3
	PHICH_RB	dB	-3	N/A	N/A
	Cell-specific reference signals		Antenna ports 0,1	Antenna ports 0,1	Antenna ports 0,1
$N_{oc}$ at antenna port	dBm/15kHz	-98			
$\bar{E}_s/N_{oc}$	dB	N/A	13.91	3.34	
BW <sub>Channel</sub>	MHz	10	10	10	
Cyclic Prefix		Normal	Normal	Normal	
Cell Id		0	1	6	
Subframe Configuration		Non-MBSFN	Non-MBSFN	Non-MBSFN	
Number of DL control region OFDM symbols		3	3	3	
CFI indicated in PCFICH		3	3	3	
PHICH Ng (Note 1)		1/6	N/A	N/A	
PHICH duration		Normal	N/A	N/A	
PDSCH TM		4	N/A	N/A	
Interference model		NA	As specified in clause B.7.1	As specified in clause B.7.1	
Unused RE-s and PRB-s (Note 2)		OCNG	OCNG	OCNG	
Time Offset relative to Cell 1	$\mu$ s	N/A	2	3	
Frequency shift relative to Cell 1	Hz	N/A	200	300	
Note 1: According to Clause 6.9 in TS 36.211 [4].					
Note 2: For Cell 2 and Cell 3 unused RE-s and PRB-s do not include control region REs.					

**Table 8.4.1.2.6-2: Minimum Performance for PDCCH/PCFICH for Enhanced Downlink Control Channel Performance Requirement Type A**

Test Number	Aggregation level	Reference Channel	OCNG Pattern (Note 1)	Propagation Conditions (Note 2)			Antenna Configuration and Correlation Matrix (Note 3)	Reference Value	
				Cell 1	Cell 2	Cell 3		Pm-dsg (%)	SNR (dB) (Note 4)
1	4 CCE	R.16-2 FDD	OP.1 FDD	EPA5	EPA5	EPA5	2x2 Low	1	12.8
Note 1: The OCNG pattern applies for Cell 1, Cell 2 and Cell 3.									
Note 2: The propagation conditions for Cell 1, Cell 2 and Cell 3 are statistically independent.									
Note 3: The correlation matrix and antenna configuration apply for Cell 1, Cell 2 and Cell 3.									
Note 4: SNR corresponds to $\bar{E}_s/N_{oc}$ of Cell 1 as defined in clause 8.1.1.									

#### 8.4.1.2.7 Enhanced Downlink Control Channel Performance Requirement Type B - 2 Tx Antenna Port with Colliding CRS Dominant Interferer

The purpose of this test is to verify the Enhanced Downlink Control Channel Performance Requirement Type B for PDCCH/PCFICH with 2 transmit antennas for the case of dominant interferer with the colliding CRS pattern and applying interference model defined in clause B.7.1. For the parameters specified in Table 8.4.1-1 and Table 8.4.1.2.7-1, the average probability of a missed downlink scheduling grant (Pm-dsg) shall be below the specified value in Table 8.4.1.2.7-2. In Table 8.4.1.2.7-1, Cell 1 is the serving cell, and Cell 2 and Cell 3 are the aggressor cells. The downlink physical channel setup is according to Annex C.3.2 for each of Cell 1, Cell 2 and Cell 3, respectively. The CRS assistance information [7] is provided and includes Cell 2 and Cell 3.

Table 8.4.1.2.7-1: Test Parameters for PDCCH/PCFICH

Parameter	Unit	Cell 1	Cell 2	Cell 3	
Downlink power allocation	PDCCH_RA OCNG_RA	dB	-3	-3	-3
	PHICH_RA	dB	-3	N/A	N/A
	PCFICH_RB PDCCH_RB OCNG_RB	dB	-3	-3	-3
	PHICH_RB	dB	-3	N/A	N/A
	Cell-specific reference signals		Antenna ports 0,1	Antenna ports 0,1	Antenna ports 0,1
$N_{oc}$ at antenna port	dBm/15kHz	-98			
$E_s/N_{oc}$	dB	N/A	13.91	3.34	
$BW_{channel}$	MHz	10	10	10	
Cyclic Prefix		Normal	Normal	Normal	
Cell Id		0	6	1	
Subframe Configuration		Non-MBSFN	Non-MBSFN	Non-MBSFN	
Number of DL control region OFDM symbols		1	1	1	
CFI indicated in PCFICH		1	1	1	
PHICH Ng (Note 1)		1/6	N/A	N/A	
PHICH duration		Normal	N/A	N/A	
PDSCH TM		4	N/A	N/A	
Interference model		NA	As specified in clause B.7.1	As specified in clause B.7.1	
Unused RE-s and PRB-s (Note 2)		OCNG	OCNG	OCNG	
Time Offset relative to Cell 1	$\mu$ s	N/A	2	3	
Frequency shift relative to Cell 1	Hz	N/A	200	300	
Note 1: According to Clause 6.9 in TS 36.211 [4].					
Note 2: For Cell 2 and Cell 3 unused RE-s and PRB-s do not include control region REs.					

Table 8.4.1.2.7-2: Minimum Performance for PDCCH/PCFICH for Enhanced Downlink Control Channel Performance Requirement Type B

Test Number	Aggregation level	Reference Channel	OCNG Pattern (Note 1)	Propagation Conditions (Note 2)			Antenna Configuration and Correlation Matrix (Note 3)	Reference Value	
				Cell 1	Cell 2	Cell 3		Pm-dsg (%)	SNR (dB) (Note 4)
1	2 CCE	R.16-3 FDD	OP.1 FDD	EPA5	EPA5	EPA5	2x2 Low	1	12.7
Note 1: The OCNG pattern applies for Cell 1, Cell 2 and Cell 3.									
Note 2: The propagation conditions for Cell 1, Cell 2 and Cell 3 are statistically independent.									
Note 3: The correlation matrix and antenna configuration apply for Cell 1, Cell 2 and Cell 3.									
Note 4: SNR corresponds to $E_s/N_{oc}$ of Cell 1 as defined in clause 8.1.1.									

#### 8.4.1.2.8 Enhanced Downlink Control Channel Performance Requirement Type B - 2 Tx Antenna Port with Non-Colliding CRS Dominant Interferer

The purpose of this test is to verify the Enhanced Downlink Control Channel Performance Requirement Type B for PDCCH/PCFICH with 2 transmit antennas for the case of dominant interferer with the non-colliding CRS pattern and applying interference model defined in clause B.7.1. For the parameters specified in Table 8.4.1-1 and Table 8.4.1.2.8-1, the average probability of a missed downlink scheduling grant (Pm-dsg) shall be below the specified value in Table 8.4.1.2.8-2. In Table 8.4.1.2.8-1, Cell 1 is the serving cell, and Cell 2 and Cell 3 are the aggressor cells. The downlink physical channel setup is according to Annex C.3.2 for each of Cell 1, Cell 2 and Cell 3, respectively. The CRS assistance information [7] is provided and includes Cell 2 and Cell 3.

Table 8.4.1.2.8-1: Test Parameters for PDCCH/PCFICH

Parameter	Unit	Cell 1	Cell 2	Cell 3	
Downlink power allocation	PDCCH_RA OCNG_RA	dB	-3	-3	-3
	PHICH_RA	dB	-3	N/A	N/A
	PCFICH_RB PDCCH_RB OCNG_RB	dB	-3	-3	-3
	PHICH_RB	dB	-3	N/A	N/A
	Cell-specific reference signals		Antenna ports 0,1	Antenna ports 0,1	Antenna ports 0,1
$N_{oc}$ at antenna port	dBm/15kHz	-98			
$E_s/N_{oc}$	dB	N/A	13.91	3.34	
$BW_{channel}$	MHz	10	10	10	
Cyclic Prefix		Normal	Normal	Normal	
Cell Id		0	1	6	
Subframe Configuration		Non-MBSFN	Non-MBSFN	Non-MBSFN	
Number of DL control region OFDM symbols		1	1	1	
CFI indicated in PCFICH		1	1	1	
PHICH Ng (Note 1)		1/6	N/A	N/A	
PHICH duration		Normal	N/A	N/A	
PDSCH TM		4	N/A	N/A	
Interference model			As specified in clause B.7.1	As specified in clause B.7.1	
Unused RE-s and PRB-s (Note 2)		OCNG	OCNG	OCNG	
Time Offset relative to Cell 1	$\mu$ s	N/A	2	3	
Frequency shift relative to Cell 1	Hz	N/A	200	300	
Note 1: According to Clause 6.9 in TS 36.211 [4].					
Note 2: For Cell 2 and Cell 3 unused RE-s and PRB-s do not include control region REs.					

Table 8.4.1.2.8-2: Minimum Performance for PDCCH/PCFICH for Enhanced Downlink Control Channel Performance Requirement Type B

Test Number	Aggregation level	Reference Channel	OCNG Pattern (Note 1)	Propagation Conditions (Note 2)			Antenna Configuration and Correlation Matrix (Note 3)	Reference Value	
				Cell 1	Cell 2	Cell 3		Pm-dsg (%)	SNR (dB) (Note 4)
1	4 CCE	R.16-4 FDD	OP.1 FDD	EPA5	EPA5	EPA5	2x2 Low	1	10.3
Note 1: The OCNG pattern applies for Cell 1, Cell 2 and Cell 3.									
Note 2: The propagation conditions for Cell 1, Cell 2 and Cell 3 are statistically independent.									
Note 3: The correlation matrix and antenna configuration apply for Cell 1, Cell 2 and Cell 3.									
Note 4: SNR corresponds to $E_s/N_{oc}$ of Cell 1 as defined in clause 8.1.1.									

#### 8.4.1.2.9 Enhanced Downlink Control Channel Performance Requirement Type A - 4 Tx Antenna Port with Non-Colliding CRS Dominant Interferer

The purpose of this test is to verify the Enhanced Downlink Control Channel Performance Requirement Type A for PDCCH/PCFICH with 4 transmit antennas for the case of dominant interferer with the non-colliding CRS pattern and applying interference model defined in clause B.7.1.

For the parameters specified in Table 8.4.1-1 and Table 8.4.1.2.9-1, the average probability of a missed downlink scheduling grant (Pm-dsg) shall be below the specified value in Table 8.4.1.2.9-2. In Table 8.4.1.2.9-1, Cell 1 is the serving cell, and Cell 2 and Cell 3 are the aggressor cells. The downlink physical channel setup is according to Annex C.3.2 for each of Cell 1, Cell 2 and Cell 3, respectively. The CRS assistance information [7] is provided and includes information on Cell 2 and Cell 3.

Table 8.4.1.2.8-1: Test Parameters for PDCCH/PCFICH

Parameter		Unit	Cell 1	Cell 2	Cell 3
Downlink power allocation	PDCCH_RA	dB	-3	-3	-3
	OCNG_RA				
	PHICH_RA	dB	-3	N/A	N/A
	PCFICH_RB				
	PDCCH_RB OCNG_RB	dB	-3	-3	-3
	PHICH_RB	dB	-3	N/A	N/A
Cell-specific reference signals			Antenna ports 0,1,2,3		
$N_{oc}$ at antenna port		dBm/15kHz	-98		
$\bar{E}_s/N_{oc}$		dB	As defined in Table 8.4.1.2.9-2	13.91	3.34
BW <sub>Channel</sub>		MHz	10	10	10
Cyclic Prefix			Normal	Normal	Normal
Cell ID			0	1	6
Subframe Configuration			Non-MBSFN	Non-MBSFN	Non-MBSFN
Number of DL control region OFDM symbols			2	2	2
CFI indicated in PCFICH			2	2	2
PHICH Ng (Note 1)			1/6	N/A	N/A
PHICH duration			Normal	N/A	N/A
PDSCH TM			4	N/A	N/A
Interference model			NA	As specified in clause B.7.1	As specified in clause B.7.1
Unused RE-s and PRB-s (Note 2)			OCNG	OCNG	OCNG
Time Offset relative to Cell 1		$\mu$ s	N/A	2	3
Frequency shift relative to Cell 1		Hz	N/A	200	300
Note 1: According to Clause 6.9 in TS 36.211 [4].					
Note 2: For Cell 2 and Cell 3 unused RE-s and PRB-s do not include control region REs.					

Table 8.4.1.2.9-2: Minimum Performance for PDCCH/PCFICH for Enhanced Downlink Control Channel Performance Requirement Type A

Test Number	Aggregation level	Reference Channel	OCNG Pattern (Note 1)	Propagation Conditions (Note 2)			Antenna Configuration and Correlation Matrix (Note 3)	Reference Value	
				Cell 1	Cell 2	Cell 3		Pm-dsg (%)	SNR (dB) (Note 4)
1	2 CCE	R.17-1 FDD	OP.1 FDD	EPA5	EPA5	EPA5	4x2 Low	1	14.1
Note 1: The OCNG pattern applies for Cell 1, Cell 2 and Cell 3.									
Note 2: The propagation conditions for Cell 1, Cell 2 and Cell 3 are statistically independent.									
Note 3: The correlation matrix and antenna configuration apply for Cell 1, Cell 2 and Cell 3.									
Note 4: SNR corresponds to $E_s/N_{oc}$ of Cell 1 as defined in clause 8.1.1.									

## 8.4.2 TDD

The parameters specified in Table 8.4.2-1 are valid for all TDD tests unless otherwise stated.

**Table 8.4.2-1: Test Parameters for PDCCH/PCFICH**

Parameter		Unit	Single antenna port	Transmit diversity
Uplink downlink configuration (Note 1)			0	0
Special subframe configuration (Note 2)			4	4
Number of PDCCH symbols		symbols	2	2
PHICH Ng (Note 3)			1	1
PHICH duration			Normal	Normal
Unused RE-s and PRB-s			OCNG	OCNG
Cell ID			0	0
Downlink power allocation	PDCCH_RA PHICH_RA OCNG_RA	dB	0	-3
	PCFICH_RB PDCCH_RB PHICH_RB OCNG_RB	dB	0	-3
$N_{oc}$ at antenna port		dBm/15kHz	-98	-98
Cyclic prefix			Normal	Normal
ACK/NACK feedback mode			Multiplexing	Multiplexing
Note 1: as specified in Table 4.2-2 in TS 36.211 [4].				
Note 2: as specified in Table 4.2-1 in TS 36.211 [4].				
Note 3: According to Clause 6.9 in TS 36.211 [4].				

### 8.4.2.1 Single-antenna port performance

For the parameters specified in Table 8.4.2-1 the average probability of a missed downlink scheduling grant (Pm-dsg) shall be below the specified value in Table 8.4.2.1-1. The downlink physical setup is in accordance with Annex C.3.2.

**Table 8.4.2.1-1: Minimum performance PDCCH/PCFICH**

Test number	Bandwidth	Aggregation level	Reference Channel	OCNG Pattern	Propagation Condition	Antenna configuration and correlation Matrix	Reference value	
							Pm-dsg (%)	SNR (dB)
1	10 MHz	8 CCE	R.15 TDD	OP.1 TDD	ETU70	1x2 Low	1	-1.6

### 8.4.2.2 Transmit diversity performance

#### 8.4.2.2.1 Minimum Requirement 2 Tx Antenna Port

For the parameters specified in Table 8.4.2-1 the average probability of a missed downlink scheduling grant (Pm-dsg) shall be below the specified value in Table 8.4.2.2.1-1. The downlink physical setup is in accordance with Annex C.3.2.

**Table 8.4.2.2.1-1: Minimum performance PDCCH/PCFICH**

Test number	Bandwidth	Aggregation level	Reference Channel	OCNG Pattern	Propagation Condition	Antenna configuration and correlation Matrix	Reference value	
							Pm-dsg (%)	SNR (dB)
1	10 MHz	4 CCE	R.16 TDD	OP.1 TDD	EVA70	2 x 2 Low	1	0.1

#### 8.4.2.2.2 Minimum Requirement 4 Tx Antenna Port

For the parameters specified in Table 8.4.2-1 the average probability of a missed downlink scheduling grant (Pm-dsg) shall be below the specified value in Table 8.4.2.2-1. The downlink physical setup is in accordance with Annex C.3.2.

**Table 8.4.2.2-1: Minimum performance PDCCH/PCFICH**

Test number	Bandwidth	Aggregation level	Reference Channel	OCNG Pattern	Propagation Condition	Antenna configuration and correlation Matrix	Reference value	
							Pm-dsg (%)	SNR (dB)
1	5 MHz	2 CCE	R.17 TDD	OP.1 TDD	EPA5	4 x 2 Medium	1	6.5

#### 8.4.2.2.3 Minimum Requirement 2 Tx Antenna Port (demodulation subframe overlaps with aggressor cell ABS)

For the parameters for non-MBSFN ABS specified in Table 8.4.2-1 and Table 8.4.2.2.3-1, the average probability of a missed downlink scheduling grant (Pm-dsg) shall be below the specified value in Table 8.4.2.2.3-2. The downlink physical setup is in accordance with Annex C.3.2 and Annex C.3.3.. In Table 8.4.2.2.3-1, Cell 1 is the serving cell, and Cell 2 is the aggressor cell. The downlink physical channel setup for Cell 1 is according to Annex C.3.2 and for Cell 2 is according to Annex C.3.3, respectively.

For the parameters for MBSFN ABS specified in Table 8.4.2-1 and Table 8.4.2.2.3-3, the average probability of a missed downlink scheduling grant (Pm-dsg) shall be below the specified value in Table 8.4.2.2.3-4. The downlink physical channel setup for Cell 1 is according to Annex C.3.2 and for Cell 2 is according to Annex C.3.3, respectively.

Table 8.4.2.2.3-1: Test Parameters for PDCCH/PCFICH – Non-MBSFN ABS

Parameter		Unit	Cell 1	Cell 2
Uplink downlink configuration			1	1
Special subframe configuration			4	4
Downlink power allocation	PDCCH_RA PHICH_RA OCNG_RA	dB	-3	-3
	PCFICH_RB PDCCH_RB PHICH_RB OCNG_RB	dB	-3	-3
$N_{oc}$ at antenna port	$N_{oc1}$	dBm/15kHz	-100.5 (Note 1)	N/A
	$N_{oc2}$	dBm/15kHz	-98 (Note 2)	N/A
	$N_{oc3}$	dBm/15kHz	-95.3 (Note 3)	N/A
$E_s/N_{oc2}$		dB	Reference Value in Table 8.4.2.2.3-2	1.5
BW <sub>Channel</sub>		MHz	10	10
Subframe Configuration			Non-MBSFN	Non-MBSFN
Time Offset between Cells		μs	2.5 (synchronous cells)	
Cell Id			0	1
ABS pattern (Note 4)			N/A	0000010001 0000000001
RLM/RRM Measurement Subframe Pattern (Note 5)			0000000001 0000000001	N/A
CSI Subframe Sets (Note 6)	C <sub>CSI,0</sub>		0000010001 0000000001	N/A
	C <sub>CSI,1</sub>		1100101000 1100111000	N/A
Number of control OFDM symbols			3	3
ACK/NACK feedback mode			Multiplexing	N/A
PHICH Ng (Note 9)			1	N/A
PHICH duration			extended	N/A
Unused RE-s and PRB-s			OCNG	OCNG
Cyclic prefix			Normal	Normal
<p>Note 1: This noise is applied in OFDM symbols #1, #2, #3, #5, #6, #8, #9, #10, #12, #13 of a subframe overlapping with the aggressor ABS.</p> <p>Note 2: This noise is applied in OFDM symbols #0, #4, #7, #11 of a subframe overlapping with the aggressor ABS.</p> <p>Note 3: This noise is applied in OFDM symbols of a subframe overlapping with aggressor non-ABS</p> <p>Note 4: ABS pattern as defined in [9]. PDCCH/PCFICH other than that associated with SIB1/Paging are transmitted in the serving cell subframe when the subframe is overlapped with the ABS subframe of aggressor cell.</p> <p>Note 5: Time-domain measurement resource restriction pattern for PCell measurements as defined in [7].</p> <p>Note 6: As configured according to the time-domain measurement resource restriction pattern for CSI measurements defined in [7].</p> <p>Note 7: Cell 1 is the serving cell. Cell 2 is the aggressor cell. The number of the CRS ports in Cell1 and Cell2 is the same.</p> <p>Note 8: SIB-1 will not be transmitted in Cell2 in the test.</p> <p>Note 9: According to Clause 6.9 in TS 36.211 [4]</p>				

Table 8.4.2.2.3-2: Minimum performance PDCCH/PCFICH – Non-MBSFN ABS

Test Number	Aggregation Level	Reference Channel	OCNG Pattern		Propagation Conditions (Note 1)		Correlation Matrix and Antenna Configuration	Reference Value	
			Cell 1	Cell 2	Cell 1	Cell 2		Pm-dsg (%)	SNR (dB) (Note 2)
1	8 CCE	R15-1 TDD	OP.1 TDD	OP.1 TDD	EVA5	EVA5	2x2 Low	1	-3.9
<p>Note 1: The propagation conditions for Cell 1 and Cell 2 are statistically independent.</p> <p>Note 2: SNR corresponds to <math>E_s/N_{oc2}</math> of cell 1.</p> <p>Note 3: The correlation matrix and antenna configuration apply for Cell 1 and Cell 2.</p>									



Table 8.4.2.2.3-3: Test Parameters for PDCCH/PCFICH – MBSFN ABS

Parameter	Unit	Cell 1	Cell 2	
Uplink downlink configuration		1	1	
Special subframe configuration		4	4	
Downlink power allocation	PDCCH_RA PHICH_RA OCNG_RA	dB	-3	-3
	PCFICH_RB PDCCH_RB PHICH_RB OCNG_RB	dB	-3	-3
$N_{oc}$ at antenna port	$N_{oc1}$	dBm/15kHz	-100.5 (Note 1)	N/A
	$N_{oc2}$	dBm/15kHz	-98 (Note 2)	N/A
	$N_{oc3}$	dBm/15kHz	-95.3 (Note 3)	N/A
$E_s/N_{oc2}$	dB	Reference Value in Table 8.4.2.2.3-4	1.5	
$BW_{Channel}$	MHz	10	10	
Subframe Configuration		Non-MBSFN	MBSFN	
Time Offset between Cells	$\mu$ s	2.5 (synchronous cells)		
Cell Id		0	126	
ABS pattern (Note 4)		N/A	000000001 000000001	
RLM/RRM Measurement Subframe Pattern(Note 5)		000000001 000000001	N/A	
CSI Subframe Sets(Note 6)	$C_{CSI,0}$	000000001 000000001	N/A	
	$C_{CSI,1}$	1100111000 1100111000	N/A	
MBSFN Subframe Allocation (Note 9)		N/A	000010	
Number of control OFDM symbols		3	3	
ACK/NACK feedback mode		Multiplexing	N/A	
PHICH Ng (Note 10)		1	N/A	
PHICH duration		extended	N/A	
Unused RE-s and PRB-s		OCNG	OCNG	
Cyclic prefix		Normal	Normal	
Note 1:	This noise is applied in OFDM symbols #1, #2, #3, #4, #5, #6, #7, #8, #9, #10, #11, #12, #13 of a subframe overlapping with the aggressor ABS.			
Note 2:	This noise is applied in OFDM symbols #0 of a subframe overlapping with the aggressor ABS.			
Note 3:	This noise is applied in OFDM symbols of a subframe overlapping with aggressor non-ABS			
Note 4:	ABS pattern as defined in [9]. The 10 <sup>th</sup> and 20 <sup>th</sup> subframes indicated by ABS pattern are MBSFN ABS subframes. PDSCH other than SIB1/paging and its associated PDCCH/PCFICH are transmitted in the serving cell subframe when the subframe is overlapped with the MBSFN ABS subframe of aggressor cell and the subframe is available in the definition of the reference channel.			
Note 5:	Time-domain measurement resource restriction pattern for PCell measurements as defined in [7].			
Note 6:	As configured according to the time-domain measurement resource restriction pattern for CSI measurements defined in [7].			
Note 7:	Cell 1 is the serving cell. Cell 2 is the aggressor cell. The number of the CRS ports in Cell1 and Cell2 is the same.			
Note 8:	SIB-1 will not be transmitted in Cell2 in this test.			
Note 9:	MBSFN Subframe Allocation as defined in [7], one frame with 6 bits is chosen for MBSFN subframe allocation.			
Note 10:	According to Clause 6.9 in TS 36.211 [4]			

Table 8.4.2.2.3-4: Minimum performance PDCCH/PCFICH – MBSFN ABS

Test Number	Aggregation Level	Reference Channel	OCNG Pattern		Propagation Conditions(Note 1)		Correlation Matrix and Antenna Configuration	Reference Value	
			Cell 1	Cell 2	Cell 1	Cell 2		Pm-dsg (%)	SNR (dB) (Note 2)
1	8 CCE	R15-1 TDD	OP.1 TDD	OP.1 TDD	EVA5	EVA5	2x2 Low	1	-4.1

Note 1: The propagation conditions for Cell 1 and Cell2 are statistically independent.

Note 2: SNR corresponds to  $E_s/N_{oc2}$  of cell 1.

Note 3: The correlation matrix and antenna configuration apply for Cell 1 and Cell 2.

#### 8.4.2.2.4 Minimum Requirement 2 Tx Antenna Port (demodulation subframe overlaps with aggressor cell ABS and CRS assistance information are configured)

For the parameters for non-MBSFN ABS specified in Table 8.4.2-1 and Table 8.4.2.2.4-1, the average probability of a missed downlink scheduling grant (Pm-dsg) shall be below the specified value in Table 8.4.2.2.4-2.

For the parameters for MBSFN ABS specified in Table 8.4.2-1 and Table 8.4.2.2.4-3, the average probability of a missed downlink scheduling grant (Pm-dsg) shall be below the specified value in Table 8.4.2.2.4-4.

In Tables 8.4.2.2.4-1 and 8.4.2.2.4-3, Cell 1 is the serving cell, and Cell 2 and Cell 3 are the aggressor cells. The downlink physical channel setup for Cell 1 is according to Annex C.3.2 and for Cell 2 and Cell 3 is according to Annex C.3.3, respectively. The CRS assistance information [7] including Cell 2 and Cell 3 is provided.

Table 8.4.2.2.4-1: Test Parameters for PDCCH/PCFICH – Non-MBSFN ABS

Parameter	Unit	Cell 1	Cell 2	Cell 3	
Uplink downlink configuration		1	1	1	
Special subframe configuration		4	4	4	
Downlink power allocation	PDCCH_RA PHICH_RA OCNG_RA	dB	-3	-3	-3
	PCFICH_RB PDCCH_RB PHICH_RB OCNG_RB	dB	-3	-3	-3
$N_{oc}$ at antenna port	$N_{oc1}$	dBm/15kHz	-98(Note 1)	N/A	N/A
	$N_{oc2}$	dBm/15kHz	-98 (Note 2)	N/A	N/A
	$N_{oc3}$	dBm/15kHz	-93 (Note 3)	N/A	N/A
$\hat{E}_s/N_{oc2}$	dB	Reference Value in Table 8.4.2.2.4-2	5	3	
BW <sub>Channel</sub>	MHz	10	10	10	
Subframe Configuration		Non-MBSFN	Non-MBSFN	Non-MBSFN	
Time Offset between Cells	μs	N/A	3	-1	
Frequency shift between Cells	Hz	N/A	300	-100	
Cell Id		0	126	1	
ABS pattern (Note 4)		N/A	0000000001 0000000001	0000000001 0000000001	
RLM/RRM Measurement Subframe Pattern (Note 5)		0000000001 0000000001	N/A	N/A	
CSI Subframe Sets (Note 6)	C <sub>CSI,0</sub>	0000000001 0000000001	N/A	N/A	
	C <sub>CSI,1</sub>	1100111000 1100111000	N/A	N/A	
Number of control OFDM symbols		2	Note 7	Note 7	
ACK/NACK feedback mode		Multiplexing	N/A	N/A	
PHICH Ng (Note 10)		1	N/A	N/A	
PHICH duration		Normal	N/A	N/A	
Unused RE-s and PRB-s		OCNG	OCNG	OCNG	
Cyclic prefix		Normal	Normal	Normal	
Note 1:	This noise is applied in OFDM symbols #1, #2, #3, #5, #6, #8, #9, #10, #12, #13 of a subframe overlapping with the aggressor ABS.				
Note 2:	This noise is applied in OFDM symbols #0, #4, #7, #11 of a subframe overlapping with the aggressor ABS.				
Note 3:	This noise is applied in all OFDM symbols of a subframe overlapping with aggressor non-ABS				
Note 4:	ABS pattern as defined in [9]. PDCCH/PCFICH other than that associated with SIB1/Paging are transmitted in the serving cell subframe when the subframe is overlapped with the ABS subframe of aggressor cell.				
Note 5:	Time-domain measurement resource restriction pattern for PCell measurements as defined in [7];				
Note 6:	As configured according to the time-domain measurement resource restriction pattern for CSI measurements defined in [7];				
Note 7:	The number of control OFDM symbols is not available for ABS and is 2 for the subframe indicated by "0" of ABS pattern.				
Note 8:	The number of the CRS ports in Cell1, Cell2 and Cell 3is the same.				
Note 9:	SIB-1 will not be transmitted in Cell2 and Cell 3 in the test.				
Note 10:	According to Clause 6.9 in TS 36.211 [4]				

Table 8.4.2.2.4-2: Minimum performance PDCCH/PCFICH – Non-MBSFN ABS

Test Number	Aggregation Level	Reference Channel	OCNG Pattern			Propagation Conditions (Note 1)			Correlation Matrix and Antenna Configuration (Note 2)	Reference Value	
			Cell 1	Cell 2	Cell 3	Cell 1	Cell 2	Cell3		Pm-dsg (%)	SNR (dB) (Note 3)
1	8 CCE	R.15-2 TDD	OP.1 TDD	OP.1 TDD	OP.1 TDD	EVA5	EVA5	EVA5	2x2 Low	1	-2.0
<p>Note 1: The propagation conditions for Cell 1, Cell 2 and Cell 3 are statistically independent.</p> <p>Note 2: The correlation matrix and antenna configuration apply for Cell 1, Cell 2 and Cell 3.</p> <p>Note 3: SNR corresponds to <math>\hat{E}_s / N_{oc2}</math> of cell 1.</p>											

Table 8.4.2.2.4-3: Test Parameters for PDCCH/PCFICH – MBSFN ABS

Parameter	Unit	Cell 1	Cell 2	Cell 3	
Uplink downlink configuration		1	1	1	
Special subframe configuration		4	4	4	
Downlink power allocation	PDCCH_RA PHICH_RA OCNG_RA	dB	-3	-3	-3
	PCFICH_RB PDCCH_RB PHICH_RB OCNG_RB	dB	-3	-3	-3
$N_{oc}$ at antenna port	$N_{oc1}$	dBm/15kHz	-98 (Note 1)	N/A	N/A
	$N_{oc2}$	dBm/15kHz	-98 (Note 2)	N/A	N/A
	$N_{oc3}$	dBm/15kHz	-93 (Note 3)	N/A	N/A
$\hat{E}_s/N_{oc2}$	dB	Reference Value in Table 8.4.2.2.4-4	5	3	
$BW_{channel}$	MHz	10	10	10	
Subframe Configuration		Non-MBSFN	MBSFN	MBSFN	
Time Offset between Cells	$\mu$ s	N/A	3	-1	
Frequency shift between Cells	Hz	N/A	300	-100	
Cell Id		0	126	1	
ABS pattern (Note 4)		N/A	000000001 000000001	000000001 000000001	
RLM/RRM Measurement Subframe Pattern (Note 5)		000000001 000000001	N/A	N/A	
CSI Subframe Sets (Note 6)	$C_{CSI,0}$	000000001 000000001	N/A	N/A	
	$C_{CSI,1}$	1100111000 1100111000	N/A	N/A	
MBSFN Subframe Allocation (Note 7)		N/A	000010	000010	
Number of control OFDM symbols		2	Note 8	Note 8	
ACK/NACK feedback mode		Multiplexing	N/A	N/A	
PHICH Ng (Note 11)		1	N/A	N/A	
PHICH duration		Normal	N/A	N/A	
Unused RE-s and PRB-s		OCNG	OCNG	OCNG	
Cyclic prefix		Normal	Normal	Normal	
Note 1:	This noise is applied in OFDM symbols #1, #2, #3, #4, #5, #6, #7, #8, #9, #10, #11, #12, #13 of a subframe overlapping with the aggressor ABS.				
Note 2:	This noise is applied in OFDM symbols #0 of a subframe overlapping with the aggressor ABS.				
Note 3:	This noise is applied in OFDM symbols of a subframe overlapping with aggressor non-ABS				
Note 4:	ABS pattern as defined in [9]. The 10 <sup>th</sup> and 20 <sup>th</sup> subframes indicated by ABS pattern are MBSFN ABS subframes. PDSCH other than SIB1/paging and its associated PDCCH/PCFICH are transmitted in the serving cell subframe when the subframe is overlapped with the MBSFN ABS subframe of aggressor cell and the subframe is available in the definition of the reference channel.				
Note 5:	Time-domain measurement resource restriction pattern for PCell measurements as defined in [7].				
Note 6:	As configured according to the time-domain measurement resource restriction pattern for CSI measurements defined in [7].				
Note 7:	MBSFN Subframe Allocation as defined in [7], one frame with 6 bits is chosen for MBSFN subframe allocation.				
Note 8:	The number of control OFDM symbols is not available for ABS and is 2 for the subframe indicated by "0" of ABS pattern.				
Note 9:	Cell 1 is the serving cell. Cell 2 is the aggressor cell. The number of the CRS ports in Cell1 and Cell2 is the same.				
Note 10:	SIB-1 will not be transmitted in Cell2 in this test.				
Note 11:	According to Clause 6.9 in TS 36.211 [4]				

Table 8.4.2.2.4-4: Minimum performance PDCCH/PCFICH – MBSFN ABS

Test Number	Aggregation Level	Reference Channel	OCNG Pattern			Propagation Conditions (Note 1)			Correlation Matrix and Antenna Configuration (Note 2)	Reference Value	
			Cell 1	Cell 2	Cell 3	Cell 1	Cell 2	Cell 3		Pm-dsg (%)	SNR (dB) (Note 3)
1	8 CCE	R.15-2 TDD	OP.1 TDD	OP.1 TDD	OP.1 TDD	EVA5	EVA5	EVA5	2x2 Low	1	-1.8
Note 1: The propagation conditions for Cell 1, Cell 2 and Cell 3 are statistically independent. Note 2: The correlation matrix and antenna configuration apply for Cell 1, Cell 2 and Cell 3. Note 3: SNR corresponds to $\bar{E}_s/N_{oc2}$ of cell 1.											

#### 8.4.2.2.5 Enhanced Downlink Control Channel Performance Requirement Type A - 2 Tx Antenna Port with Colliding CRS Dominant Interferer

The purpose of this test is to verify the Enhanced Downlink Control Channel Performance Requirement Type A for PDCCH/PCFICH with 2 transmit antennas for the case of dominant interferer with the colliding CRS pattern and applying interference model defined in clause B.7.1. For the parameters specified in Table 8.4.2-1 and Table 8.4.2.2.5-1, the average probability of a missed downlink scheduling grant (Pm-dsg) shall be below the specified value in Table 8.4.2.2.5-2. In Table 8.4.2.2.5-1, Cell 1 is the serving cell, and Cell 2 and Cell 3 are the aggressor cells. The downlink physical channel setup is according to Annex C.3.2 for each of Cell 1, Cell 2 and Cell 3, respectively. The CRS assistance information [7] is provided and includes Cell 2 and Cell 3.

Table 8.4.2.2.5-1: Test Parameters for PDCCH/PCFICH

Parameter	Unit	Cell 1	Cell 2	Cell 3	
Downlink power allocation	PDCCH_RA	-3	-3	-3	
	OCNG_RA	-3	-3	-3	
	PHICH_RA	-3	N/A	N/A	
	PCFICH_RB	-3	-3	-3	
	PDCCH_RB	-3	-3	-3	
Cell-specific reference signals	OCNG_RB	-3	-3	-3	
	PHICH_RB	-3	N/A	N/A	
	Antenna ports	0,1	0,1	0,1	
	$N_{oc}$ at antenna port	dBm/15kHz	-98	-98	-98
	$\bar{E}_s/N_{oc}$	dB	N/A	13.91	3.34
BW <sub>Channel</sub>	MHz	10	10	10	
Cyclic Prefix		Normal	Normal	Normal	
Cell Id		0	6	1	
UL/DL Configuration		0	0	0	
Special Subframe Configuration		4	4	4	
Subframe Configuration		Non-MBSFN	Non-MBSFN	Non-MBSFN	
Number of DL control region OFDM symbols			3 for subframes 0 and 5 2 for subframes 1 and 6		
CFI indicated in PCFICH			3 for subframes 0 and 5 2 for subframes 1 and 6		
PHICH Ng (Note 1)		1/6	N/A	N/A	
PHICH duration		Normal	N/A	N/A	
PDSCH TM		4	N/A	N/A	
Interference model			As specified in clause B.7.1	As specified in clause B.7.1	
Unused RE-s and PRB-s (Note 2)		OCNG	OCNG	OCNG	
Time Offset relative to Cell 1	μs	N/A	2	3	
Frequency shift relative to Cell 1	Hz	N/A	200	300	
Note 1: According to Clause 6.9 in TS 36.211 [4].					
Note 2: For Cell 2 and Cell 3 unused RE-s and PRB-s do not include control region REs.					

**Table 8.4.2.2.5-2: Minimum Performance for PDCCH/PCFICH for Enhanced Downlink Control Channel Performance Requirement Type A**

Test Number	Aggregation level	Reference Channel	OCNG Pattern (Note 1)	Propagation Conditions (Note 2)			Antenna Configuration and Correlation Matrix (Note 3)	Reference Value	
				Cell 1	Cell 2	Cell 3		Pm-dsg (%)	SNR (dB) (Note 4)
1	2 CCE	R.16-1 TDD	OP.1 TDD	EPA5	EPA5	EPA5	2x2 Low	1	16.1
Note 1: The OCNG pattern applies for Cell 1, Cell 2 and Cell 3. Note 2: The propagation conditions for Cell 1, Cell 2 and Cell 3 are statistically independent. Note 3: The correlation matrix and antenna configuration apply for Cell 1, Cell 2 and Cell 3. Note 4: SNR corresponds to $E_s/N_{oc}$ of Cell 1 as defined in clause 8.1.1.									

#### 8.4.2.2.6 Enhanced Downlink Control Channel Performance Requirement Type A - 2 Tx Antenna Port with Non-Colliding CRS Dominant Interferer

The purpose of this test is to verify the Enhanced Downlink Control Channel Performance Requirement Type A for PDCCH/PCFICH with 2 transmit antennas for the case of dominant interferer with the non-colliding CRS pattern and applying interference model defined in clause B.7.1. For the parameters specified in Table 8.4.2-1 and Table 8.4.2.2.6-1, the average probability of a missed downlink scheduling grant (Pm-dsg) shall be below the specified value in Table 8.4.2.2.6-2. In Table 8.4.2.2.6-1, Cell 1 is the serving cell, and Cell 2 and Cell 3 are the aggressor cells. The downlink physical channel setup is according to Annex C.3.2 for each of Cell 1, Cell 2 and Cell 3, respectively. The CRS assistance information [7] is provided and includes Cell 2 and Cell 3.

**Table 8.4.2.2.6-1: Test Parameters for PDCCH/PCFICH**

Parameter	Unit	Cell 1	Cell 2	Cell 3
Downlink power allocation	PDCCH_RA	-3	-3	-3
	OCNG_RA	-3	-3	-3
	PHICH_RA	-3	N/A	N/A
	PCFICH_RB	-3	-3	-3
Cell-specific reference signals	PDCCH_RB	-3	-3	-3
	OCNG_RB	-3	-3	-3
	PHICH_RB	-3	N/A	N/A
	PHICH_RB	-3	N/A	N/A
$N_{oc}$ at antenna port	dBm/15kHz	Antenna ports 0,1	Antenna ports 0,1	Antenna ports 0,1
$\tilde{E}_s/N_{oc}$	dB	N/A	13.91	3.34
$BW_{channel}$	MHz	10	10	10
Cyclic Prefix		Normal	Normal	Normal
Cell Id		0	1	6
UL/DL Configuration		0	0	0
Special Subframe Configuration		4	4	4
Subframe Configuration		Non-MBSFN	Non-MBSFN	Non-MBSFN
Number of DL control region OFDM symbols			3 for subframes 0 and 5 2 for subframes 1 and 6	
CFI indicated in PCFICH			3 for subframes 0 and 5 2 for subframes 1 and 6	
PHICH Ng (Note 1)		1/6	N/A	N/A
PHICH duration		Normal	N/A	N/A
PDSCH TM		4	N/A	N/A
Interference model			As specified in clause B.7.1	As specified in clause B.7.1
Unused RE-s and PRB-s (Note 2)		OCNG	OCNG	OCNG
Time Offset relative to Cell 1	$\mu$ s	N/A	2	3
Frequency shift relative to Cell 1	Hz	N/A	200	300
Note 1: According to Clause 6.9 in TS 36.211 [4]. Note 2: For Cell 2 and Cell 3 unused RE-s and PRB-s do not include control region REs.				

**Table 8.4.2.2.6-2: Minimum Performance for PDCCH/PCFICH for Enhanced Downlink Control Channel Performance Requirement Type A**

Test Number	Aggregation level	Reference Channel	OCNG Pattern (Note 1)	Propagation Conditions (Note 2)			Antenna Configuration and Correlation Matrix (Note 3)	Reference Value	
				Cell 1	Cell 2	Cell 3		Pm-dsg (%)	SNR (dB) (Note 4)
1	4 CCE	R.16-2 TDD	OP.1 TDD	EPA5	EPA5	EPA5	2x2 Low	1	13.3
Note 1: The OCNG pattern applies for Cell 1, Cell 2 and Cell 3. Note 2: The propagation conditions for Cell 1, Cell 2 and Cell 3 are statistically independent. Note 3: The correlation matrix and antenna configuration apply for Cell 1, Cell 2 and Cell 3. Note 4: SNR corresponds to $E_s/N_{oc}$ of Cell 1 as defined in clause 8.1.1.									

#### 8.4.2.2.7 Enhanced Downlink Control Channel Performance Requirement Type B - 2 Tx Antenna Port with Colliding CRS Dominant Interferer

The purpose of this test is to verify the Enhanced Downlink Control Channel Performance Requirement Type B for PDCCH/PCFICH with 2 transmit antennas for the case of dominant interferer with the colliding CRS pattern and applying interference model defined in clause B.7.1. For the parameters specified in Table 8.4.2-1 and Table 8.4.2.2.7-1, the average probability of a missed downlink scheduling grant (Pm-dsg) shall be below the specified value in Table 8.4.2.2.7-2. In Table 8.4.2.2.7-1, Cell 1 is the serving cell, and Cell 2 and Cell 3 are the aggressor cells. The downlink physical channel setup is according to Annex C.3.2 for each of Cell 1, Cell 2 and Cell 3, respectively. The CRS assistance information [7] is provided and includes Cell 2 and Cell 3.

**Table 8.4.2.2.7-1: Test Parameters for PDCCH/PCFICH**

Parameter		Unit	Cell 1	Cell 2	Cell 3
Downlink power allocation	PDCCH_RA OCNG_RA	dB	-3	-3	-3
	PHICH_RA	dB	-3	N/A	N/A
	PCFICH_RB PDCCH_RB OCNG_RB	dB	-3	-3	-3
	PHICH_RB	dB	-3	N/A	N/A
Cell-specific reference signals			Antenna ports 0,1	Antenna ports 0,1	Antenna ports 0,1
$N_{oc}$ at antenna port		dBm/15kHz	-98		
$\bar{E}_s/N_{oc}$		dB	N/A	13.91	3.34
$BW_{channel}$		MHz	10	10	10
Cyclic Prefix			Normal	Normal	Normal
Cell Id			0	6	1
UL/DL Configuration			0	0	0
Special Subframe Configuration			4	4	4
Subframe Configuration			Non-MBSFN	Non-MBSFN	Non-MBSFN
Number of DL control region OFDM symbols			1	1	1
CFI indicated in PCFICH			1	1	1
PHICH Ng (Note 1)			1/6	N/A	N/A
PHICH duration			Normal	N/A	N/A
PDSCH TM			4	N/A	N/A
Interference model				As specified in clause B.7.1	As specified in clause B.7.1
Unused RE-s and PRB-s (Note 2)			OCNG	OCNG	OCNG
Time Offset relative to Cell 1		$\mu$ s	N/A	2	3
Frequency shift relative to Cell 1		Hz	N/A	200	300
Note 1: According to Clause 6.9 in TS 36.211 [4]. Note 2: For Cell 2 and Cell 3 unused RE-s and PRB-s do not include control region REs.					



**Table 8.4.2.2.7-2: Minimum Performance for PDCCH/PCFICH for Enhanced Downlink Control Channel Performance Requirement Type B**

Test Number	Aggregation level	Reference Channel	OCNG Pattern (Note 1)	Propagation Conditions (Note 2)			Antenna Configuration and Correlation Matrix (Note 3)	Reference Value	
				Cell 1	Cell 2	Cell 3		Pm-dsg (%)	SNR (dB) (Note 4)
1	2 CCE	R.16-3 TDD	OP.1 TDD	EPA5	EPA5	EPA5	2x2 Low	1	13.7
Note 1: The OCNG pattern applies for Cell 1, Cell 2 and Cell 3. Note 2: The propagation conditions for Cell 1, Cell 2 and Cell 3 are statistically independent. Note 3: The correlation matrix and antenna configuration apply for Cell 1, Cell 2 and Cell 3. Note 4: SNR corresponds to $E_s/N_{oc}$ of Cell 1 as defined in clause 8.1.1.									

#### 8.4.2.2.8 Enhanced Downlink Control Channel Performance Requirement Type B - 2 Tx Antenna Port with Non-Colliding CRS Dominant Interferer

The purpose of this test is to verify the Enhanced Downlink Control Channel Performance Requirement Type A for PDCCH/PCFICH with 2 transmit antennas for the case of dominant interferer with the non-colliding CRS pattern and applying interference model defined in clause B.7.1. For the parameters specified in Table 8.4.2-1 and Table 8.4.2.2.8-1, the average probability of a missed downlink scheduling grant (Pm-dsg) shall be below the specified value in Table 8.4.2.2.8-2. In Table 8.4.2.2.8-1, Cell 1 is the serving cell, and Cell 2 and Cell 3 are the aggressor cells. The downlink physical channel setup is according to Annex C.3.2 for each of Cell 1, Cell 2 and Cell 3, respectively. The CRS assistance information [7] is provided and includes Cell 2 and Cell 3.

**Table 8.4.2.2.8-1: Test Parameters for PDCCH/PCFICH**

Parameter		Unit	Cell 1	Cell 2	Cell 3
Downlink power allocation	PDCCH_RA OCNG_RA	dB	-3	-3	-3
	PHICH_RA	dB	-3	N/A	N/A
	PCFICH_RB PDCCH_RB OCNG_RB	dB	-3	-3	-3
	PHICH_RB	dB	-3	N/A	N/A
Cell-specific reference signals			Antenna ports 0,1	Antenna ports 0,1	Antenna ports 0,1
$N_{oc}$ at antenna port		dBm/15kHz	-98		
$\bar{E}_s/N_{oc}$		dB	N/A	13.91	3.34
$BW_{channel}$		MHz	10	10	10
Cyclic Prefix			Normal	Normal	Normal
Cell Id			0	1	6
UL/DL Configuration			0	0	0
Special Subframe Configuration			4	4	4
Subframe Configuration			Non-MBSFN	Non-MBSFN	Non-MBSFN
Number of DL control region OFDM symbols			1	1	1
CFI indicated in PCFICH			1	1	1
PHICH Ng (Note 1)			1/6	N/A	N/A
PHICH duration			Normal	N/A	N/A
PDSCH TM			4	N/A	N/A
Interference model				As specified in clause B.7.1	As specified in clause B.7.1
Unused RE-s and PRB-s (Note 2)			OCNG	OCNG	OCNG
Time Offset relative to Cell 1		$\mu$ s	N/A	2	3
Frequency shift relative to Cell 1		Hz	N/A	200	300
Note 1: According to Clause 6.9 in TS 36.211 [4]. Note 2: For Cell 2 and Cell 3 unused RE-s and PRB-s do not include control region REs.					

**Table 8.4.2.2.8-2: Minimum Performance for PDCCH/PCFICH for Enhanced Downlink Control Channel Performance Requirement Type B**

Test Number	Aggregation level	Reference Channel	OCNG Pattern (Note 1)	Propagation Conditions (Note 2)			Antenna Configuration and Correlation Matrix (Note 3)	Reference Value	
				Cell 1	Cell 2	Cell 3		Pm-dsg (%)	SNR (dB) (Note 4)
1	4 CCE	R.16-4 TDD	OP.1 TDD	EPA5	EPA5	EPA5	2x2 Low	1	11.2
Note 1: The OCNG pattern applies for Cell 1, Cell 2 and Cell 3. Note 2: The propagation conditions for Cell 1, Cell 2 and Cell 3 are statistically independent. Note 3: The correlation matrix and antenna configuration apply for Cell 1, Cell 2 and Cell 3. Note 4: SNR corresponds to $E_s/N_{oc}$ of Cell 1 as defined in clause 8.1.1.									

#### 8.4.2.2.9 Enhanced Downlink Control Channel Performance Requirement Type A - 4 Tx Antenna Port with Non-Colliding CRS Dominant Interferer

The purpose of this test is to verify the Enhanced Downlink Control Channel Performance Requirement Type A for PDCCH/PCFICH with 4 transmit antennas for the case of dominant interferer with the non-colliding CRS pattern and applying interference model defined in clause B.7.1.

For the parameters specified in Table 8.4.1-1 and Table 8.4.2.2.9-1, the average probability of a missed downlink scheduling grant (Pm-dsg) shall be below the specified value in Table 8.4.2.2.9-2. In Table 8.4.2.2.9-1, Cell 1 is the serving cell, and Cell 2 and Cell 3 are the aggressor cells. The downlink physical channel setup is according to Annex C.3.2 for each of Cell 1, Cell 2 and Cell 3, respectively. The CRS assistance information [7] is provided and includes information on Cell 2 and Cell 3.

**Table 8.4.2.2.9-1: Test Parameters for PDCCH/PCFICH**

Parameter		Unit	Cell 1	Cell 2	Cell 3
Downlink power allocation	PDCCH_RA	dB	-3	-3	-3
	OCNG_RA	dB	-3	-3	-3
	PHICH_RA	dB	-3	N/A	N/A
	PCFICH_RB	dB	-3	-3	-3
	PDCCH_RB OCNG_RB	dB	-3	-3	-3
PHICH_RB	dB	-3	N/A	N/A	
Cell-specific reference signals			Antenna ports 0,1,2,3		
$N_{oc}$ at antenna port		dBm/15kHz	-98		
$\bar{E}_s/N_{oc}$		dB	As defined in Table 8.4.1.2.9-2	13.91	3.34
BW <sub>Channel</sub>		MHz	10	10	10
Cyclic Prefix			Normal	Normal	Normal
Cell ID			0	1	6
UL/DL Configuration			0	0	0
Special Subframe Configuration			4	4	4
Subframe Configuration			Non-MBSFN	Non-MBSFN	Non-MBSFN
Number of DL control region OFDM symbols			2		
CFI indicated in PCFICH			2		
PHICH Ng (Note 1)			1/6	N/A	N/A
PHICH duration			Normal	N/A	N/A
PDSCH TM			4	N/A	N/A
Interference model			N/A	As specified in clause B.7.1	As specified in clause B.7.1
Unused RE-s and PRB-s (Note 2)			OCNG	OCNG	OCNG
Time Offset relative to Cell 1		$\mu$ s	N/A	2	3
Frequency shift relative to Cell 1		Hz	N/A	200	300
Note 1: According to Clause 6.9 in TS 36.211 [4]. Note 2: For Cell 2 and Cell 3 unused RE-s and PRB-s do not include control region REs.					

**Table 8.4.2.2.9-2: Minimum Performance for PDCCH/PCFICH for Enhanced Downlink Control Channel Performance Requirement Type A**

Test Number	Aggregation level	Reference Channel	OCNG Pattern (Note 1)	Propagation Conditions (Note 2)			Antenna Configuration and Correlation Matrix (Note 3)	Reference Value	
				Cell 1	Cell 2	Cell 3		Pm-dsg (%)	SNR (dB) (Note 4)
1	2 CCE	R.17-1 TDD	OP.1 TDD	EPA5	EPA5	EPA5	4x2 Low	1	14.4
Note 1: The OCNG pattern applies for Cell 1, Cell 2 and Cell 3. Note 2: The propagation conditions for Cell 1, Cell 2 and Cell 3 are statistically independent. Note 3: The correlation matrix and antenna configuration apply for Cell 1, Cell 2 and Cell 3. Note 4: SNR corresponds to $E_s/N_{oc}$ of Cell 1 as defined in clause 8.1.1.									

### 8.4.3 LAA

The parameters specified in Table 8.4.3-1 are valid for all LAA PDCCH tests unless otherwise stated.

**Table 8.4.3-1: Common test Parameters for PDCCH**

Parameter		Unit	Transmit diversity
Downlink power allocation (Note 1)	PDCCH_RA PHICH_RA OCNG_RA	dB	-3
	PCFICH_RB PDCCH_RB PHICH_RB OCNG_RB	dB	-3
$N_{oc}$ at antenna port		dBm/15kHz	-98
PHICH Ng (Note 1)			1
PHICH duration			Normal
Unused RE-s and PRB-s (Note 2)			OCNG
Cell ID			0
Cyclic prefix			Normal
ACK/NACK feedback mode			Multiplexing
Note 1: In LAA Scell(s), PCFICH_RB, PHICH_RA, and PHICH_RB are not available. Note 2: OCNG is applied only within LAA burst.			

#### 8.4.3.1 Transmit diversity performance

##### 8.4.3.1.1 FDD Pcell (FDD single carrier)

###### 8.4.3.1.1.1 Minimum Requirement 2 Tx Antenna Port

The average probability of a missed downlink scheduling grant (Pm-dsg) shall be below the specified value in Table 8.4.3.1.1.1-2 for Pcell and in Table 8.4.3.1.1.1-3 for LAA Scell(s), with the addition of the parameters in Table 8.4.3-1, and Table 8.4.3.1.1.1-1. The downlink physical setup is in accordance with Annex C.3.2.

Table 8.4.3.1.1.1-1: Test Parameters for LAA Scell(s)

Parameter	Unit	Value
DMTC Periodicity	ms	80
dmtc-PeriodOffset-r12 ms80-r12		0
Downlink Burst transmission pattern for LAA SCell		As specified in B.8
The number of subframes set ( $S_i$ ) in a burst		{1,3, 5, 8}
Uniform random number ( $\rho$ ) in the burst model		0.5
Occupied OFDM symbols set in the last subframe		{6, 9, 12,14}
timing error relative of LAA SCell to PCell	$\mu$ s	15
Frequency offset of th $i$ -th LAA SCell relative to PCell	Hz	200
Note 1: The same PDSCH transmission mode is applied to each component carrier. Note 2: The OCNNG shall be applied for the non-scheduled OFDM symbols within the burst, and which OFDM symbols are scheduled within the burst is according to UE capability.		

Table 8.4.3.1.1.1-2: Single carrier performance for CCs which are not LAA Scells for multiple CA configurations

Test number	Bandwidth	Aggregation level	Reference Channel	OCNG Pattern	Propagation Condition	Antenna configuration and correlation Matrix	Reference value	
							Pm-dsg (%)	SNR (dB)
1	10 MHz	4 CCE	R.16 FDD	OP.1 FDD	EVA5	2 x 2 Low	1	-0.6

Table 8.4.3.1.1.1-3: Single carrier performance for LAA Scell(s) for multiple CA configurations

Test number	Bandwidth	Aggregation level	Reference Channel	OCNG Pattern	Propagation Condition	Antenna configuration and correlation Matrix	Reference value	
							Pm-dsg (%)	SNR (dB)
1	20 MHz	4 CCE	R.3 FS3	OP.1 FS3	EVA5	2 x 2 Low	1	0.2
2	20 MHz	4 CCE	R.3 FS3	OP.1 FS3	EVA5	2 x 2 Low	1	0.2
3	20 MHz	4 CCE	R.3 FS3	OP.1 FS3	EVA5	2 x 2 Low	1	0.3
4	20 MHz	4 CCE	R.3 FS3	OP.1 FS3	EVA5	2 x 2 Low	1	0.1
Note1 : UE is required to fulfill only one test among test 1-4 depending on it's capability for endingDwPTS and secondSlotStartingPosition. For UE don't support endingDwPTS and secondSlotStartingPosition, it is required to fulfill test 1; For UE don't support endingDwPTS and support secondSlotStartingPosition, it is required to fulfill test 2; For UE support endingDwPTS and don't support secondSlotStartingPosition, it is required to fulfill test 3; and For UE support both endingDwPTS and secondSlotStartingPosition, it is required to fulfill test 4.								

### 8.4.3.1.2 TDD Pcell (TDD single carrier)

#### 8.4.3.1.2.1 Minimum Requirement 2 Tx Antenna Port

The average probability of a missed downlink scheduling grant (Pm-dsg) shall be below the specified value in Table 8.4.3.1.2.1-2 for Pcell and in Table 8.4.3.1.2.1-3 for LAA Scell(s), with the additional of the parameters in Table 8.4.3-1, and Table 8.4.3.1.2.1-1. The downlink physical setup is in accordance with Annex C.3.2.

Table 8.4.3.1.2.1-1: Test Parameters for LAA Scell(s)

Parameter	Unit	Value
DMTC Periodicity	ms	80
dmtc-PeriodOffset-r12 ms80-r12		0
Downlink Burst transmission pattern for LAA SCell		As specified in B.8
The number of subframes set ( $S_i$ ) in a burst		{1,3, 5, 8}
Uniform random number ( $\rho$ ) in the burst model		0.5
subframeStartPosition		's07'
Occupied OFDM symbols set in the last subframe		{6, 9, 12,14}
timing error relative of LAA SCell to PCell	$\mu$ s	15
Frequency offset of th $i$ -th LAA SCell relative to PCell	Hz	200
Note 1: The same PDSCH transmission mode is applied to each component carrier. Note 2: The OCNNG shall be applied for the non-scheduled OFDM symbols within the burst, and which OFDM symbols are scheduled within the burst is according to UE capability.		

Table 8.4.3.1.2.1-2: Single carrier performance for CCs which are not LAA Scells for multiple CA configurations

Test number	Bandwidth	Aggregation level	Reference Channel	OCNG Pattern	Propagation Condition	Antenna configuration and correlation Matrix	Reference value	
							Pm-dsg (%)	SNR (dB)
1	10 MHz	4 CCE	R.16 TDD	OP.1 TDD	EVA5	2 x 2 Low	1	-0.6

Table 8.4.3.1.2.1-3: Single carrier performance for LAA Scell(s) for multiple CA configurations

Test number	Bandwidth	Aggregation level	Reference Channel	OCNG Pattern	Propagation Condition	Antenna configuration and correlation Matrix	Reference value	
							Pm-dsg (%)	SNR (dB)
1	20 MHz	4 CCE	R.4 FS3	OP.1 FS3	EVA5	2 x 2 Low	1	0.2
2	20 MHz	4 CCE	R.4 FS3	OP.1 FS3	EVA5	2 x 2 Low	1	0.2
3	20 MHz	4 CCE	R.4 FS3	OP.1 FS3	EVA5	2 x 2 Low	1	0.3
4	20 MHz	4 CCE	R.4 FS3	OP.1 FS3	EVA5	2 x 2 Low	1	0.1
Note1 : UE is required to fulfill only one test among test 1-4 depending on it's capability for endingDwPTS and secondSlotStartingPosition. For UE don't support endingDwPTS and secondSlotStartingPosition, it is required to fulfill test 1; For UE don't support endingDwPTS and support secondSlotStartingPosition, it is required to fulfill test 2; For UE support endingDwPTS and don't support secondSlotStartingPosition, it is required to fulfill test 3; and For UE support both endingDwPTS and secondSlotStartingPosition, it is required to fulfill test 4.								

## 8.5 Demodulation of PHICH

The receiver characteristics of the PHICH are determined by the probability of miss-detecting an ACK for a NACK ( $P_{m-an}$ ). It is assumed that there is no bias applied to the detection of ACK and NACK (zero-threshold detection).

### 8.5.1 FDD

The parameters specified in Table 8.5.1-1 are valid for all FDD tests unless otherwise stated.

**Table 8.5.1-1: Test Parameters for PHICH**

Parameter		Unit	Single antenna port	Transmit diversity
Downlink power allocation	PDCCH_RA PHICH_RA OCNG_RA	dB	0	-3
	PCFICH_RB PDCCH_RB PHICH_RB OCNG_RB	dB	0	-3
PHICH duration			Normal	Normal
PHICH Ng (Note 1)			Ng = 1	Ng = 1
PDCCH Content			UL Grant should be included with the proper information aligned with A.3.6.	
Unused RE-s and PRB-s			OCNG	OCNG
Cell ID			0	0
$N_{oc}$ at antenna port		dBm/15kHz	-98	-98
Cyclic prefix			Normal	Normal
Note 1: according to Clause 6.9 in TS 36.211 [4]				

#### 8.5.1.1 Single-antenna port performance

For the parameters specified in Table 8.5.1-1 the average probability of a miss-detecting ACK for NACK ( $P_{m-an}$ ) shall be below the specified value in Table 8.5.1.1-1. The downlink physical setup is in accordance with Annex C.3.2.

**Table 8.5.1.1-1: Minimum performance PHICH**

Test number	Bandwidth	Reference Channel	OCNG Pattern	Propagation Condition	Antenna configuration and correlation Matrix	Reference value	
						$P_{m-an}$ (%)	SNR (dB)
1	10 MHz	R.18	OP.1 FDD	ETU70	1 x 2 Low	0.1	5.5
2	10 MHz	R.24	OP.1 FDD	ETU70	1 x 2 Low	0.1	0.6

#### 8.5.1.2 Transmit diversity performance

##### 8.5.1.2.1 Minimum Requirement 2 Tx Antenna Port

For the parameters specified in Table 8.5.1-1 the average probability of a miss-detecting ACK for NACK ( $P_{m-an}$ ) shall be below the specified value in Table 8.5.1.2-1. The downlink physical setup is in accordance with Annex C.3.2.

**Table 8.5.1.2.1-1: Minimum performance PHICH**

Test number	Bandwidth	Reference Channel	OCNG Pattern	Propagation Condition	Antenna configuration and correlation Matrix	Reference value	
						Pm-an (%)	SNR (dB)
1	10 MHz	R.19	OP.1 FDD	EVA70	2 x 2 Low	0.1	4.4
1A	5MHz (Note 1)	R.19-1	OP.1 FDD	EVA 70	2x2 Low	0.1	4

Note 1: Test case applicability is defined in 8.1.2.1.

**8.5.1.2.2 Minimum Requirement 4 Tx Antenna Port**

For the parameters specified in Table 8.5.1-1 the average probability of a miss-detecting ACK for NACK (Pm-an) shall be below the specified value in Table 8.5.1.2.2-1. The downlink physical setup is in accordance with Annex C.3.2.

**Table 8.5.1.2.2-1: Minimum performance PHICH**

Test number	Bandwidth	Reference Channel	OCNG Pattern	Propagation Condition	Antenna configuration and correlation Matrix	Reference value	
						Pm-an (%)	SNR (dB)
1	5 MHz	R.20	OP.1 FDD	EPA5	4 x 2 Medium	0.1	6.1

**8.5.1.2.3 Minimum Requirement 2 Tx Antenna Port (demodulation subframe overlaps with aggressor cell ABS)**

For the parameters specified in Table 8.5.1-1 and Table 8.5.1.2.3-1, the average probability of a miss-detecting ACK for NACK (Pm-an) shall be below the specified value in Table 8.5.1.2.3-2. The downlink physical setup is in accordance with Annex C.3.2 and Annex C.3.3. In Table 8.5.1.2.3-1, Cell 1 is the serving cell, and Cell 2 is the aggressor cell. The downlink physical channel setup for Cell 1 is according to Annex C.3.2 and for Cell 2 is according to Annex C.3.3, respectively.

Table 8.5.1.2.3-1: Test Parameters for PHICH

Parameter		Unit	Cell 1	Cell 2
Downlink power allocation	PDCCH_RA PHICH_RA OCNG_RA	dB	-3	-3
	PCFICH_RB PDCCH_RB PHICH_RB OCNG_RB	dB	-3	-3
$N_{oc}$ at antenna port	$N_{oc1}$	dBm/15kHz	-100.5 (Note 1)	N/A
	$N_{oc2}$	dBm/15kHz	-98 (Note 2)	N/A
	$N_{oc3}$	dBm/15kHz	-95.3 (Note 3)	N/A
$E_s/N_{oc2}$		dB	Reference Value in Table 8.5.1.2.3- 2	1.5
BW <sub>Channel</sub>		MHz	10	10
Subframe Configuration			Non-MBSFN	Non-MBSFN
Time Offset between Cells		μs	2.5 (synchronous cells)	
Cell Id			0	1
ABS pattern (Note 4)			N/A	00000100 00000100 00000100 01000100 00000100
RLM/RRM Measurement Subframe Pattern (Note 5)			00000100 00000100 00000100 00000100 00000100	N/A
CSI Subframe Sets (Note 6)	$C_{CSI,0}$		00000100 00000100 00000100 01000100 00000100	N/A
	$C_{CSI,1}$		11111011 11111011 11111011 10111011 11111011	N/A
Number of control OFDM symbols			3	3
PHICH Ng (Note 9)			1	N/A
PHICH duration			extended	N/A
Unused RE-s and PRB-s			OCNG	OCNG
Cyclic prefix			Normal	Normal
<p>Note 1: This noise is applied in OFDM symbols #1, #2, #3, #5, #6, #8, #9, #10, #12, #13 of a subframe overlapping with the aggressor ABS</p> <p>Note 2: This noise is applied in OFDM symbols #0, #4, #7, #11 of a subframe overlapping with the aggressor ABS</p> <p>Note 3: This noise is applied in OFDM symbols of a subframe overlapping with aggressor non-ABS</p> <p>Note 4: ABS pattern as defined in [9]. PHICH is transmitted in the serving cell subframe when the subframe is overlapped with the ABS subframe of aggressor cell but not in the 26<sup>th</sup> subframe indicated by the ABS pattern.</p> <p>Note 5: Time-domain measurement resource restriction pattern for PCell measurements as defined in [7]</p> <p>Note 6: As configured according to the time-domain measurement resource restriction pattern for CSI measurements defined in [7]</p> <p>Note 7: Cell 1 is the serving cell. Cell 2 is the aggressor cell. The number of the CRS ports in Cell1 and Cell2 is the same.</p> <p>Note 8: SIB-1 will not be transmitted in Cell2 in the test.</p> <p>Note 9: According to Clause 6.9 in TS 36.211 [4]</p>				



Table 8.5.1.2.3-2: Minimum performance PHICH

Test Number	Reference Channel	OCNG Pattern		Propagation Conditions (Note 1)		Antenna Configuration and Correlation Matrix	Reference Value	
		Cell 1	Cell 2	Cell 1	Cell 2		Pm-an (%)	SNR (dB) (Note 2)
1	R.19	OP.1 FDD	OP.1 FDD	EPA5	EPA5	2x2 Low	0.1	4.6
Note 1: The propagation conditions for Cell 1 and Cell 2 are statistically independent.								
Note 2: SNR corresponds to $E_s/N_{oc2}$ of cell 1.								
Note 3: The correlation matrix and antenna configuration apply for Cell 1 and Cell 2.								

#### 8.5.1.2.4 Minimum Requirement 2 Tx Antenna Port (demodulation subframe overlaps with aggressor cell ABS and CRS assistance information are configured)

For the parameters specified in Table 8.5.1-1 and Table 8.5.1.2.4-1, the average probability of a miss-detecting ACK for NACK (Pm-an) shall be below the specified value in Table 8.5.1.2.4-2. In Table 8.5.1.2.4-1, Cell 1 is the serving cell, and Cell 2 and Cell 3 are the aggressor cells. The downlink physical channel setup for Cell 1 is according to Annex C.3.2 and for Cell 2 and Cell 3 is according to Annex C.3.3, respectively. The CRS assistance information [7] including Cell 2 and Cell 3 is provided.

**Table 8.5.1.2.4-1: Test Parameters for PHICH**

Parameter		Unit	Cell 1	Cell 2	Cell 3
Downlink power allocation	PDCCH_RA PHICH_RA OCNG_RA	dB	-3	-3	-3
	PCFICH_RB PDCCH_RB PHICH_RB OCNG_RB	dB	-3	-3	-3
$N_{oc}$ at antenna port	$N_{oc1}$	dBm/15kHz	-98 (Note 1)	N/A	N/A
	$N_{oc2}$	dBm/15kHz	-98 (Note 2)	N/A	N/A
	$N_{oc3}$	dBm/15kHz	-93 (Note 3)	N/A	N/A
$\hat{E}_s/N_{oc2}$		dB	Reference Value in Table 8.5.1.2.4-2	5	3
BW <sub>Channel</sub>		MHz	10	10	10
Subframe Configuration			Non-MBSFN	Non-MBSFN	Non-MBSFN
Time Offset between Cells		μs	N/A	3	-1
Frequency shift between Cells		Hz	N/A	300	-100
Cell Id			0	126	1
PDCCH Content			UL Grant should be included with the proper information aligned with A.3.6.	N/A	N/A
ABS pattern (Note 4)			N/A	00000100 00000100 00000100 00000100 00000100	00000100 00000100 00000100 00000100 00000100
RLM/RRM Measurement Subframe Pattern (Note 5)			00000100 00000100 00000100 00000100 00000100	N/A	N/A
CSI Subframe Sets (Note 6)	C <sub>CSI,0</sub>		00000100 00000100 00000100 00000100 00000100	N/A	N/A
	C <sub>CSI,1</sub>		11111011 11111011 11111011 11111011 11111011	N/A	N/A
Number of control OFDM symbols			2	Note 7	Note 7
PHICH Ng (Note 10)			1	N/A	N/A
PHICH duration			Normal	N/A	N/A
Unused RE-s and PRB-s			OCNG	OCNG	OCNG
Cyclic prefix			Normal	Normal	Normal

Note 1:	This noise is applied in OFDM symbols #1, #2, #3, #5, #6, #8, #9, #10, #12, #13 of a subframe overlapping with the aggressor ABS
Note 2:	This noise is applied in OFDM symbols #0, #4, #7, #11 of a subframe overlapping with the aggressor ABS
Note 3:	This noise is applied in OFDM symbols of a subframe overlapping with aggressor non-ABS
Note 4:	ABS pattern as defined in [9]. PHICH is transmitted in the serving cell subframe when the subframe is overlapped with the ABS subframe of aggressor cell but not in the 26 <sup>th</sup> subframe indicated by the ABS pattern.
Note 5:	Time-domain measurement resource restriction pattern for PCell measurements as defined in [7]
Note 6:	As configured according to the time-domain measurement resource restriction pattern for CSI measurements defined in [7]
Note 7:	The number of control OFDM symbols is not available for ABS and is 2 for the subframe indicated by "0" of ABS pattern.
Note 8:	The number of the CRS ports in Cell 1, Cell 2 and Cell 3 is the same.
Note 9:	SIB-1 will not be transmitted in Cell 2 and Cell 3 in the test
Note 10:	According to Clause 6.9 in TS 36.211 [4].

Table 8.5.1.2.4-2: Minimum performance PHICH

Test Number	Reference Channel	OCNG Pattern			Propagation Conditions (Note 1)			Antenna Configuration and Correlation Matrix (Note 2)	Reference Value	
		Cell 1	Cell 2	Cell 3	Cell 1	Cell 2	Cell 3		Pm-an (%)	SNR (dB) (Note 3)
1	R.19	OP.1 FDD	OP.1 FDD	OP.1 FDD	EPA5	EVA5	EVA5	2x2 Low	0.1	5.0
Note 1:	The propagation conditions for Cell 1, Cell 2 and Cell 3 are statistically independent.									
Note 2:	The correlation matrix and antenna configuration apply for Cell 1, Cell 2 and Cell 3.									
Note 3:	SNR corresponds to $\hat{E}_s/N_{oc2}$ of Cell 1.									

#### 8.5.1.2.5 Enhanced Downlink Control Channel Performance Requirement Type A - 2 Tx Antenna Ports under Asynchronous Network

For the parameters specified in Table 8.5.1-1 and Table 8.5.1.2.5-1, the average probability of a miss-detecting ACK for NACK (Pm-an) shall be below the specified value in Table 8.5.1.2.5-2. The purpose of this test is to verify the PHICH performance with 2 transmit antennas when the serving cell PHICH transmission is interfered by two interfering cells and applying interference model defined in clause B.5.2. In Table 8.5.1.2.5-1, Cell 1 is the serving cell, and Cell 2 and Cell 3 are the aggressor cells. The downlink physical channel setup is according to Annex C.3.2 for each of Cell 1, Cell 2 and Cell 3, respectively. The CRS assistance information [7] is not provided.

Table 8.5.1.2.5-1: Test Parameters for PHICH

Parameter		Unit	Cell 1	Cell 2	Cell 3
Downlink power allocation	PDCCH_RA PHICH_RA PDSCH_RA OCNG_RA	dB	-3	-3	-3
	PCFICH_RB PHICH_RB PDCCH_RB PDSCH_RB OCNG_RB	dB	-3	-3	-3
Cell-specific reference signals			Antenna ports 0,1	Antenna ports 0,1	Antenna ports 0,1
$N_{oc}$ at antenna port		dBm/15kHz	-98		
$\bar{E}_s/N_{oc}$		dB	N/A	13.91	3.34
$BW_{channel}$		MHz	10	10	10
Cyclic Prefix			Normal	Normal	Normal
Cell ID			0	1	6
Subframe Configuration			Non-MBSFN	Non-MBSFN	Non-MBSFN
Number of control OFDM symbols			1	1	1
PHICH Ng (Note 1)			1	N/A	N/A
PHICH duration			Normal	N/A	N/A
Interference model			N/A	As specified in clause B.5.2	As specified in clause B.5.2
Probability of occurrence of PDSCH transmission rank in interfering cells	Rank 1	%	N/A	80	80
	Rank 2	%	N/A	20	20
Unused RE-s and PRB-s			OCNG	OCNG	OCNG
Time offset relative to Cell 1		ms	N/A	0.33	0.67
Frequency offset relative to Cell 1		Hz	N/A	0	0

Note 1: According to Clause 6.9 in TS 36.211 [4].

Table 8.5.1.2.5-2: Minimum performance PHICH for Enhanced Downlink Control Channel Performance Requirement Type A

Test Number	Reference Channel	OCNG Pattern			Propagation Conditions (Note 1)			Antenna Configuration and Correlation Matrix (Note 2)	Reference Value	
		Cell 1	Cell 2	Cell 3	Cell 1	Cell 2	Cell 3		Pm-an (%)	SNR (dB) (Note 3)
1	R.19	OP.1 FDD	OP.1 FDD	OP.1 FDD	EVA7 0	EVA7 0	EVA7 0	2x2 Low	0.1	17.9

Note 1: The propagation conditions for Cell 1, Cell 2 and Cell 3 are statistically independent.  
Note 2: The correlation matrix and antenna configuration apply for Cell 1, Cell 2 and Cell 3.  
Note 3: SNR corresponds to  $\bar{E}_s/N_{oc2}$  of Cell 1 as defined in clause 8.1.1.

### 8.5.1.2.6 Enhanced Downlink Control Channel Performance Requirement Type A - 2 Tx Antenna Ports with Non-Colliding CRS Dominant Interferer

For the parameters specified in Table 8.5.1-1 and Table 8.5.1.2.6-1, the average probability of a miss-detecting ACK for NACK (Pm-an) shall be below the specified value in Table 8.5.1.2.6-2. The purpose of this test is to verify the PHICH performance with 2 transmit antennas when the serving cell PHICH transmission is interfered by two interfering cells with the dominant interferer having the non-colliding CRS pattern and applying interference model defined in clause B.7.1. In Table 8.5.1.2.6-1, Cell 1 is the serving cell, and Cell 2 and Cell 3 are the aggressor cells. The downlink physical channel setup is according to Annex C.3.2 for each of Cell 1, Cell 2 and Cell 3, respectively. The CRS assistance information [7] is provided and includes Cell 2 and Cell 3.

Table 8.5.1.2.6-1: Test Parameters for PHICH

Parameter	Unit	Cell 1	Cell 2	Cell 3	
Downlink power allocation	PDCCH_RA OCNG_RA	dB	-3	-3	-3
	PHICH_RA	dB	-3	N/A	N/A
	PCFICH_RB PDCCH_RB OCNG_RB	dB	-3	-3	-3
	PHICH_RB	dB	-3	N/A	N/A
	Cell-specific reference signals		Antenna ports 0,1	Antenna ports 0,1	Antenna ports 0,1
$N_{oc}$ at antenna port	dBm/15kHz	-98			
$\hat{E}_s/N_{oc}$	dB	N/A	13.91	3.34	
$BW_{channel}$	MHz	10	10	10	
Cyclic Prefix		Normal	Normal	Normal	
Cell ID		0	1	6	
Subframe Configuration		Non-MBSFN	Non-MBSFN	Non-MBSFN	
Number of control OFDM symbols		1	1	1	
PHICH Ng (Note 1)		1	N/A	N/A	
PHICH duration		Normal	N/A	N/A	
Interference model		N/A	As specified in clause B.7.1	As specified in clause B.7.1	
Unused RE-s and PRB-s (Note 2)		OCNG	OCNG	OCNG	
Time offset to cell 1	us	N/A	2	3	
Frequency offset to cell 1	Hz	N/A	200	300	
Note 1: According to Clause 6.9 in TS 36.211 [4].					
Note 2: For Cell 2 and Cell 3 unused RE-s and PRB-s do not include control region REs.					

Table 8.5.1.2.6-2: Minimum performance PHICH for Enhanced Downlink Control Channel Performance Requirement Type A

Test Number	Reference Channel	OCNG Pattern			Propagation Conditions (Note 1)			Antenna Configuration and Correlation Matrix (Note 2)	Reference Value	
		Cell 1	Cell 2	Cell 3	Cell 1	Cell 2	Cell 3		Pm-an (%)	SNR (dB) (Note 3)
1	R.19	OP.1 FDD	OP.1 FDD	OP.1 FDD	EPA5	EPA5	EPA5	2x2 Low	0.1	15.8
Note 1: The propagation conditions for Cell 1, Cell 2 and Cell 3 are statistically independent.										
Note 2: The correlation matrix and antenna configuration apply for Cell 1, Cell 2 and Cell 3.										
Note 3: SNR corresponds to $\hat{E}_s/N_{oc2}$ of Cell 1 as defined in clause 8.1.1.										

### 8.5.1.2.7 Enhanced Downlink Control Channel Performance Requirement Type B - 2 Tx Antenna Ports with Colliding CRS Dominant Interferer

For the parameters specified in Table 8.5.1-1 and Table 8.5.1.2.7-1, the average probability of a miss-detecting ACK for NACK (Pm-an) shall be below the specified value in Table 8.5.1.2.7-2. The purpose of this test is to verify the PHICH performance with 2 transmit antennas when the serving cell PHICH transmission is interfered by two interfering cells with the dominant interferer having the colliding CRS pattern and applying interference model defined in clause B.7.1. In Table 8.5.1.2.7-1, Cell 1 is the serving cell, and Cell 2 and Cell 3 are the aggressor cells. The downlink physical channel setup is according to Annex C.3.2 for each of Cell 1, Cell 2 and Cell 3, respectively. The CRS assistance information [7] is provided and includes Cell 2 and Cell 3.

Table 8.5.1.2.7-1: Test Parameters for PHICH

Parameter	Unit	Cell 1	Cell 2	Cell 3	
Downlink power allocation	PDCCH_RA OCNG_RA	dB	-3	-3	-3
	PHICH_RA	dB	-3	N/A	N/A
	PCFICH_RB PDCCH_RB OCNG_RB	dB	-3	-3	-3
	PHICH_RB	dB	-3	N/A	N/A
	Cell-specific reference signals		Antenna ports 0,1	Antenna ports 0,1	Antenna ports 0,1
$N_{oc}$ at antenna port	dBm/15kHz	-98			
$\hat{E}_s/N_{oc}$	dB	N/A	13.91	3.34	
$BW_{channel}$	MHz	10	10	10	
Cyclic Prefix		Normal	Normal	Normal	
Cell ID		0	6	1	
Subframe Configuration		Non-MBSFN	Non-MBSFN	Non-MBSFN	
Number of control OFDM symbols		1	1	1	
PHICH Ng (Note 1)		1	N/A	N/A	
PHICH duration		Normal	N/A	N/A	
Interference model		N/A	As specified in clause B.7.1	As specified in clause B.7.1	
Unused RE-s and PRB-s (Note 2)		OCNG	OCNG	OCNG	
Time offset to cell 1	us	N/A	2	3	
Frequency offset to cell 1	Hz	N/A	200	300	
Note 1: According to Clause 6.9 in TS 36.211 [4].					
Note 2: For Cell 2 and Cell 3 unused RE-s and PRB-s do not include control region REs.					

Table 8.5.1.2.7-2: Minimum performance PHICH for Enhanced Downlink Control Channel Performance Requirement Type B

Test Number	Reference Channel	OCNG Pattern			Propagation Conditions (Note 1)			Antenna Configuration and Correlation Matrix (Note 2)	Reference Value	
		Cell 1	Cell 2	Cell 3	Cell 1	Cell 2	Cell 3		Pm-an (%)	SNR (dB) (Note 3)
1	R.19	OP.1 FDD	OP.1 FDD	OP.1 FDD	EPA5	EPA5	EPA5	2x2 Low	0.1	13.4
Note 1: The propagation conditions for Cell 1, Cell 2 and Cell 3 are statistically independent.										
Note 2: The correlation matrix and antenna configuration apply for Cell 1, Cell 2 and Cell 3.										
Note 3: SNR corresponds to $\hat{E}_s/N_{oc2}$ of Cell 1 as defined in clause 8.1.1.										

### 8.5.1.2.8 Enhanced Downlink Control Channel Performance Requirement Type B - 2 Tx Antenna Ports with Non-Colliding CRS Dominant Interferer

For the parameters specified in Table 8.5.1-1 and Table 8.5.1.2.8-1, the average probability of a miss-detecting ACK for NACK (Pm-an) shall be below the specified value in Table 8.5.1.2.8-2. The purpose of this test is to verify the PHICH performance with 2 transmit antennas when the serving cell PHICH transmission is interfered by two interfering cells with the dominant interferer having the non-colliding CRS pattern and applying interference model defined in clause B.7.1. In Table 8.5.1.2.8-1, Cell 1 is the serving cell, and Cell 2 and Cell 3 are the aggressor cells. The downlink physical channel setup is according to Annex C.3.2 for each of Cell 1, Cell 2 and Cell 3, respectively. The CRS assistance information [7] is provided and includes Cell 2 and Cell 3.

Table 8.5.1.2.8-1: Test Parameters for PHICH

Parameter	Unit	Cell 1	Cell 2	Cell 3	
Downlink power allocation	PDCCH_RA OCNG_RA	dB	-3	-3	-3
	PHICH_RA	dB	-3	N/A	N/A
	PCFICH_RB PDCCH_RB OCNG_RB	dB	-3	-3	-3
	PHICH_RB	dB	-3	N/A	N/A
	Cell-specific reference signals		Antenna ports 0,1	Antenna ports 0,1	Antenna ports 0,1
$N_{oc}$ at antenna port	dBm/15kHz	-98			
$\hat{E}_s/N_{oc}$	dB	N/A	13.91	3.34	
$BW_{channel}$	MHz	10	10	10	
Cyclic Prefix		Normal	Normal	Normal	
Cell ID		0	1	6	
Subframe Configuration		Non-MBSFN	Non-MBSFN	Non-MBSFN	
Number of control OFDM symbols		1	1	1	
PHICH Ng (Note 1)		1	N/A	N/A	
PHICH duration		Normal	N/A	N/A	
Interference model		N/A	As specified in clause B.7.1	As specified in clause B.7.1	
Unused RE-s and PRB-s (Note 2)		OCNG	OCNG	OCNG	
Time offset to cell 1	us	N/A	2	3	
Frequency offset to cell 1	Hz	N/A	200	300	
Note 1: According to Clause 6.9 in TS 36.211 [4].					
Note 2: For Cell 2 and Cell 3 unused RE-s and PRB-s do not include control region REs.					

Table 8.5.1.2.8-2: Minimum performance PHICH for Enhanced Downlink Control Channel Performance Requirement Type B

Test Number	Reference Channel	OCNG Pattern			Propagation Conditions (Note 1)			Antenna Configuration and Correlation Matrix (Note 2)	Reference Value	
		Cell 1	Cell 2	Cell 3	Cell 1	Cell 2	Cell 3		Pm-an (%)	SNR (dB) (Note 3)
1	R.19	OP.1 FDD	OP.1 FDD	OP.1 FDD	EPA5	EPA5	EPA5	2x2 Low	0.1	15.0
Note 1: The propagation conditions for Cell 1, Cell 2 and Cell 3 are statistically independent.										
Note 2: The correlation matrix and antenna configuration apply for Cell 1, Cell 2 and Cell 3.										
Note 3: SNR corresponds to $\hat{E}_s/N_{oc2}$ of Cell 1 as defined in clause 8.1.1.										

## 8.5.2 TDD

The parameters specified in Table 8.5.2-1 are valid for all TDD tests unless otherwise stated.



Table 8.5.2-1: Test Parameters for PHICH

Parameter		Unit	Single antenna port	Transmit diversity
Uplink downlink configuration (Note 1)			1	1
Special subframe configuration (Note 2)			4	4
Downlink power allocation	PDCCH_RA PHICH_RA OCNG_RA	dB	0	-3
	PCFICH_RB PDCCH_RB PHICH_RB OCNG_RB	dB	0	-3
PHICH duration			Normal	Normal
PHICH Ng (Note 3)			Ng = 1	Ng = 1
PDCCH Content			UL Grant should be included with the proper information aligned with A.3.6.	
Unused RE-s and PRB-s			OCNG	OCNG
Cell ID			0	0
$N_{oc}$ at antenna port		dBm/15kHz	-98	-98
Cyclic prefix			Normal	Normal
ACK/NACK feedback mode			Multiplexing	Multiplexing
Note 1: as specified in Table 4.2-2 in TS 36.211 [4]				
Note 2: as specified in Table 4.2-1 in TS 36.211 [4]				
Note 3: according to Clause 6.9 in TS 36.211 [4]				

### 8.5.2.1 Single-antenna port performance

For the parameters specified in Table 8.5.2-1 the average probability of a miss-detecting ACK for NACK ( $P_{m-an}$ ) shall be below the specified value in Table 8.5.2.1-1. The downlink physical setup is in accordance with Annex C.3.2.

Table 8.5.2.1-1: Minimum performance PHICH

Test number	Bandwidth	Reference Channel	OCNG Pattern	Propagation Condition	Antenna configuration and correlation Matrix	Reference value	
						$P_{m-an}$ (%)	SNR (dB)
1	10 MHz	R.18	OP.1 TDD	ETU70	1 x 2 Low	0.1	5.8
2	10 MHz	R.24	OP.1 TDD	ETU70	1 x 2 Low	0.1	1.3

### 8.5.2.2 Transmit diversity performance

#### 8.5.2.2.1 Minimum Requirement 2 Tx Antenna Port

For the parameters specified in Table 8.5.2-1 the average probability of a miss-detecting ACK for NACK ( $P_{m-an}$ ) shall be below the specified value in Table 8.5.2.2.1-1. The downlink physical setup is in accordance with Annex C.3.2.

Table 8.5.2.2.1-1: Minimum performance PHICH

Test number	Bandwidth	Reference Channel	OCNG Pattern	Propagation Condition	Antenna configuration and correlation Matrix	Reference value	
						Pm-an (%)	SNR (dB)
1	10 MHz	R.19	OP.1 TDD	EVA70	2 x 2 Low	0.1	4.2

## 8.5.2.2.2 Minimum Requirement 4 Tx Antenna Port

For the parameters specified in Table 8.5.2-1 the average probability of a miss-detecting ACK for NACK (Pm-an) shall be below the specified value in Table 8.5.2.2.1. The downlink physical setup is in accordance with Annex C.3.2.

Table 8.5.2.2.2-1: Minimum performance PHICH

Test number	Bandwidth	Reference Channel	OCNG Pattern	Propagation Condition	Antenna configuration and correlation Matrix	Reference value	
						Pm-an (%)	SNR (dB)
1	5 MHz	R.20	OP.1 TDD	EPA5	4 x 2 Medium	0.1	6.2

## 8.5.2.2.3 Minimum Requirement 2 Tx Antenna Port (demodulation subframe overlaps with aggressor cell ABS)

For the parameters specified in Table 8.5.2-1 and Table 8.5.2.2.3-1, the average probability of a miss-detecting ACK for NACK (Pm-an) shall be below the specified value in Table 8.5.2.2.3-2. The downlink physical setup is in accordance with Annex C.3.2 and Annex C.3.3. In Table 8.5.2.2.3-1, Cell 1 is the serving cell, and Cell 2 is the aggressor cell. The downlink physical channel setup for Cell 1 is according to Annex C.3.2 and for Cell 2 is according to Annex C.3.3, respectively.

Table 8.5.2.2.3-1: Test Parameters for PHICH

Parameter		Unit	Cell 1	Cell 2
Uplink downlink configuration			1	1
Special subframe configuration			4	4
Downlink power allocation	PDCCH_RA PHICH_RA OCNG_RA	dB	-3	-3
	PCFICH_RB PDCCH_RB PHICH_RB OCNG_RB	dB	-3	-3
$N_{oc}$ at antenna port	$N_{oc1}$	dBm/15kHz	-100.5 (Note 1)	N/A
	$N_{oc2}$	dBm/15kHz	-98 (Note 2)	N/A
	$N_{oc3}$	dBm/15kHz	-95.3 (Note 3)	N/A
$E_s/N_{oc2}$		dB	Reference Value in Table 8.5.2.2.3-2	1.5
BW <sub>Channel</sub>		MHz	10	10
Subframe Configuration			Non-MBSFN	Non-MBSFN
Time Offset between Cells		μs	2.5 (synchronous cells)	
Cell Id			0	1
ABS pattern (Note 4)			N/A	0000010001 0000000001
RLM/RRM Measurement Subframe Pattern (Note 5)			0000000001 0000000001	N/A
CSI Subframe Sets (Note 6)	C <sub>CSI,0</sub>		0000010001 0000000001	N/A
	C <sub>CSI,1</sub>		1100101000 1100111000	N/A
Number of control OFDM symbols			3	3
ACK/NACK feedback mode			Multiplexing	N/A
PHICH Ng (Note 9)			1	N/A
PHICH duration			extended	N/A
Unused RE-s and PRB-s			OCNG	OCNG
Cyclic prefix			Normal	Normal
<p>Note 1: This noise is applied in OFDM symbols #1, #2, #3, #5, #6, #8, #9, #10, #12, #13 of a subframe overlapping with the aggressor ABS</p> <p>Note 2: This noise is applied in OFDM symbols #0, #4, #7, #11 of a subframe overlapping with the aggressor ABS</p> <p>Note 3: This noise is applied in OFDM symbols of a subframe overlapping with aggressor non-ABS</p> <p>Note 4: ABS pattern as defined in [9]. PHICH is transmitted in the serving cell subframe when the subframe is overlapped with the ABS subframe of aggressor cell but not in subframe 5</p> <p>Note 5: Time-domain measurement resource restriction pattern for PCell measurements as defined in [7]</p> <p>Note 6: As configured according to the time-domain measurement resource restriction pattern for CSI measurements defined in [7]</p> <p>Note 7: Cell 1 is the serving cell. Cell 2 is the aggressor cell. The number of the CRS ports in Cell1 and Cell2 is the same.</p> <p>Note 8: SIB-1 will not be transmitted in Cell2 in the test.</p> <p>Note 9: According to Clause 6.9 in TS 36.211 [4]</p>				

Table 8.5.2.2.3-2: Minimum performance PHICH

Test Number	Reference Channel	OCNG Pattern		Propagation Conditions (Note 1)		Antenna Configuration and Correlation Matrix	Reference Value	
		Cell 1	Cell 2	Cell 1	Cell 2		Pm-an (%)	SNR (dB) (Note 2)
1	R.19	OP.1 TDD	OP.1 TDD	EPA5	EPA5	2x2 Low	0.1	4.6
Note 1: The propagation conditions for Cell 1 and Cell 2 are statistically independent.								
Note 2: SNR corresponds to $E_s/N_{oc2}$ of cell 1.								
Note 3: The correlation matrix and antenna configuration apply for Cell 1 and Cell 2.								

#### 8.5.2.2.4 Minimum Requirement 2 Tx Antenna Port (demodulation subframe overlaps with aggressor cell ABS and CRS assistance information are configured)

For the parameters specified in Table 8.5.2-1 and Table 8.5.2.2.4-1, the average probability of a miss-detecting ACK for NACK (Pm-an) shall be below the specified value in Table 8.5.2.2.4-2. In Table 8.5.2.2.4-1, Cell 1 is the serving cell, and Cell 2 and Cell 3 are the aggressor cells. The downlink physical channel setup for Cell 1 is according to Annex C.3.2 and for Cell 2 and Cell 3 is according to Annex C.3.3, respectively. The CRS assistance information [7] including Cell 2 and Cell 3 is provided.

Table 8.5.2.2.4-1: Test Parameters for PHICH

Parameter		Unit	Cell 1	Cell 2	Cell 3
Uplink downlink configuration			1	1	1
Special subframe configuration			4	4	4
Downlink power allocation	PDCCH_RA PHICH_RA OCNG_RA	dB	-3	-3	-3
	PCFICH_RB PDCCH_RB PHICH_RB OCNG_RB	dB	-3	-3	-3
$N_{oc}$ at antenna port	$N_{oc1}$	dBm/15kHz	-98 (Note 1)	N/A	N/A
	$N_{oc2}$	dBm/15kHz	-98 (Note 2)	N/A	N/A
	$N_{oc3}$	dBm/15kHz	-93 (Note 3)	N/A	N/A
$\hat{E}_s/N_{oc2}$		dB	Reference Value in Table 8.5.2.2.4-2	5	3
BW <sub>Channel</sub>		MHz	10	10	10
Subframe Configuration			Non-MBSFN	Non-MBSFN	Non-MBSFN
Time Offset between Cells		μs	N/A	3	-1
Frequency shift between Cells		Hz	N/A	300	-100
Cell Id			0	126	1
PDCCH Content			UL Grant should be included with the proper information aligned with A.3.6.	N/A	N/A
ABS pattern (Note 4)			N/A	000000001 000000001	000000001 000000001
RLM/RRM Measurement Subframe Pattern (Note 5)			000000001 000000001	N/A	N/A
CSI Subframe Sets (Note 6)	$C_{CSI,0}$		000000001 000000001	N/A	N/A
	$C_{CSI,1}$		1100111000 1100111000	N/A	N/A
Number of control OFDM symbols			2	Note 7	Note 7
ACK/NACK feedback mode			Multiplexing	N/A	N/A
PHICH Ng (Note 10)			1	N/A	N/A
PHICH duration			Normal	N/A	N/A
Unused RE-s and PRB-s			OCNG	OCNG	OCNG
Cyclic prefix			Normal	Normal	Normal
Note 1: This noise is applied in OFDM symbols #1, #2, #3, #5, #6, #8, #9, #10, #12, #13 of a subframe overlapping with the aggressor ABS					
Note 2: This noise is applied in OFDM symbols #0, #4, #7, #11 of a subframe overlapping with the aggressor ABS					
Note 3: This noise is applied in OFDM symbols of a subframe overlapping with aggressor non-ABS					
Note 4: ABS pattern as defined in [9]. PHICH is transmitted in the serving cell subframe when the subframe is overlapped with the ABS subframe of aggressor cell but not in subframe 5					
Note 5: Time-domain measurement resource restriction pattern for PCell measurements as defined in [7]					
Note 6: As configured according to the time-domain measurement resource restriction pattern for CSI measurements defined in [7]					
Note 7: The number of control OFDM symbols is not available for ABS and is 2 for the subframe indicated by "0" of ABS pattern.					
Note 8: The number of the CRS ports in Cell 1, Cell 2 and Cell 3 is the same.					
Note 9: SIB-1 will not be transmitted in Cell 2 and Cell 3 in the test.					
Note 10: According to Clause 6.9 in TS 36.211 [4]					

Table 8.5.2.2.4-2: Minimum performance PHICH

Test Number	Reference Channel	OCNG Pattern			Propagation Conditions (Note 1)			Antenna Configuration and Correlation Matrix (Note 2)	Reference Value	
		Cell 1	Cell 2	Cell 3	Cell 1	Cell 2	Cell 3		Pm-an (%)	SNR (dB) (Note 3)
1	R.19	OP.1 TDD	OP.1 TDD	OP.1 TDD	EPA5	EVA5	EVA5	2x2 Low	0.1	5.7
Note 1: The propagation conditions for Cell 1, Cell 2 and Cell 3 are statistically independent.										
Note 2: The correlation matrix and antenna configuration apply for Cell 1, Cell 2 and Cell 3.										
Note 3: SNR corresponds to $\bar{E}_s/N_{oc2}$ of Cell 1.										

### 8.5.2.2.5 Enhanced Downlink Control Channel Performance Requirement Type A - 2 Tx Antenna Ports with Colliding CRS Dominant Interferer

For the parameters specified in Table 8.5.2-1 and Table 8.5.2.2.5-1, the average probability of a miss-detecting ACK for NACK (Pm-an) shall be below the specified value in Table 8.5.2.2.5-2. The purpose of this test is to verify the PHICH performance with 2 transmit antennas when the serving cell PHICH transmission is interfered by two interfering cells with the dominant interferer having the colliding CRS pattern and applying interference model defined in clause B.7.1. In Table 8.5.2.2.5-1, Cell 1 is the serving cell, and Cell 2 and Cell 3 are the aggressor cells. The downlink physical channel setup is according to Annex C.3.2 for each of Cell 1, Cell 2 and Cell 3, respectively. The CRS assistance information [7] is provided and includes Cell 2 and Cell 3.

Table 8.5.2.2.5-1: Test Parameters for PHICH

Parameter	Unit	Cell 1	Cell 2	Cell 3	
Uplink downlink configuration		1	1	1	
Special subframe configuration		4	4	4	
Downlink power allocation	PDCCH_RA	dB	-3	-3	-3
	OCNG_RA	dB	-3	N/A	N/A
	PCFICH_RB	dB	-3	-3	-3
	PDCCH_RB	dB	-3	-3	-3
	OCNG_RB	dB	-3	N/A	N/A
	PHICH_RB	dB	-3	N/A	N/A
Cell-specific reference signals		Antenna ports 0,1	Antenna ports 0,1	Antenna ports 0,1	
$N_{oc}$ at antenna port	dBm/15kHz	-98			
$\bar{E}_s/N_{oc}$	dB	N/A	13.91	3.34	
$BW_{channel}$	MHz	10	10	10	
Cyclic Prefix		Normal	Normal	Normal	
Cell ID		0	6	1	
Subframe Configuration		Non-MBSFN	Non-MBSFN	Non-MBSFN	
Number of control OFDM symbols		1	1	1	
PHICH Ng (Note 1)		1	N/A	N/A	
PHICH duration		Normal	N/A	N/A	
Interference model		N/A	As specified in clause B.7.1	As specified in clause B.7.1	
Unused RE-s and PRB-s (Note 2)		OCNG	OCNG	OCNG	
Time offset to cell 1	us	N/A	2	3	
Frequency offset to cell 1	Hz	N/A	200	300	
Note 1: According to Clause 6.9 in TS 36.211 [4].					
Note 2: For Cell 2 and Cell 3 unused RE-s and PRB-s do not include control region REs.					

**Table 8.5.2.2.5-2: Minimum performance PHICH for Enhanced Downlink Control Channel Performance Requirement Type A**

Test Number	Reference Channel	OCNG Pattern			Propagation Conditions (Note 1)			Antenna Configuration and Correlation Matrix (Note 2)	Reference Value	
		Cell 1	Cell 2	Cell 3	Cell 1	Cell 2	Cell 3		Pm-an (%)	SNR (dB) (Note 3)
1	R.19	OP.1 TDD	OP.1 TDD	OP.1 TDD	EPA5	EPA5	EPA5	2x2 Low	0.1	16.2

Note 1: The propagation conditions for Cell 1, Cell 2 and Cell 3 are statistically independent.  
Note 2: The correlation matrix and antenna configuration apply for Cell 1, Cell 2 and Cell 3.  
Note 3: SNR corresponds to  $\hat{E}_s/N_{oc2}$  of Cell 1 as defined in clause 8.1.1.

### 8.5.2.2.6 Enhanced Downlink Control Channel Performance Requirement Type A - 2 Tx Antenna Ports with Non-Colliding CRS Dominant Interferer

For the parameters specified in Table 8.5.2-1 and Table 8.5.2.2.6-1, the average probability of a miss-detecting ACK for NACK (Pm-an) shall be below the specified value in Table 8.5.2.2.6-2. The purpose of this test is to verify the PHICH performance with 2 transmit antennas when the serving cell PHICH transmission is interfered by two interfering cells with the dominant interferer having the non-colliding CRS pattern and applying interference model defined in clause B.7.1. In Table 8.5.2.2.6-1, Cell 1 is the serving cell, and Cell 2 and Cell 3 are the aggressor cells. The downlink physical channel setup is according to Annex C.3.2 for each of Cell 1, Cell 2 and Cell 3, respectively. The CRS assistance information [7] is provided and includes Cell 2 and Cell 3.

**Table 8.5.2.2.6-1: Test Parameters for PHICH**

Parameter	Unit	Cell 1	Cell 2	Cell 3	
Uplink downlink configuration		1	1	1	
Special subframe configuration		4	4	4	
Downlink power allocation	PDCCH_RA	dB	-3	-3	-3
	OCNG_RA	dB	-3	N/A	N/A
	PHICH_RA	dB	-3	N/A	N/A
	PCFICH_RB	dB	-3	-3	-3
	PDCCH_RB	dB	-3	-3	-3
Cell-specific reference signals		Antenna ports 0,1	Antenna ports 0,1	Antenna ports 0,1	
	$N_{oc}$ at antenna port	dBm/15kHz	-98	-98	-98
$\hat{E}_s/N_{oc}$	dB	N/A	13.91	3.34	
BW <sub>channel</sub>	MHz	10	10	10	
Cyclic Prefix		Normal	Normal	Normal	
Cell ID		0	1	6	
Subframe Configuration		Non-MBSFN	Non-MBSFN	Non-MBSFN	
Number of control OFDM symbols		1	1	1	
PHICH Ng (Note 1)		1	N/A	N/A	
PHICH duration		Normal	N/A	N/A	
Interference model		N/A	As specified in clause B.7.1	As specified in clause B.7.1	
Unused RE-s and PRB-s (Note 2)		OCNG	OCNG	OCNG	
Time offset to cell 1	us	N/A	2	3	
Frequency offset to cell 1	Hz	N/A	200	300	

Note 1: According to Clause 6.9 in TS 36.211 [4].  
Note 2: For Cell 2 and Cell 3 unused RE-s and PRB-s do not include control region REs.

**Table 8.5.2.2.6-2: Minimum performance PHICH for Enhanced Downlink Control Channel Performance Requirement Type A**

Test Number	Reference Channel	OCNG Pattern			Propagation Conditions (Note 1)			Antenna Configuration and Correlation Matrix (Note 2)	Reference Value	
		Cell 1	Cell 2	Cell 3	Cell 1	Cell 2	Cell 3		Pm-an (%)	SNR (dB) (Note 3)
1	R.19	OP.1 TDD	OP.1 TDD	OP.1 TDD	EPA5	EPA5	EPA5	2x2 Low	0.1	16.1

Note 1: The propagation conditions for Cell 1, Cell 2 and Cell 3 are statistically independent.  
Note 2: The correlation matrix and antenna configuration apply for Cell 1, Cell 2 and Cell 3.  
Note 3: SNR corresponds to  $\hat{E}_s/N_{oc2}$  of Cell 1 as defined in clause 8.1.1.

### 8.5.2.2.7 Enhanced Downlink Control Channel Performance Requirement Type B - 2 Tx Antenna Ports with Colliding CRS Dominant Interferer

For the parameters specified in Table 8.5.2-1 and Table 8.5.2.2.7-1, the average probability of a miss-detecting ACK for NACK (Pm-an) shall be below the specified value in Table 8.5.2.2.7-2. The purpose of this test is to verify the PHICH performance with 2 transmit antennas when the serving cell PHICH transmission is interfered by two interfering cells with the dominant interferer having the colliding CRS pattern and applying interference model defined in clause B.7.1. In Table 8.5.2.2.7-1, Cell 1 is the serving cell, and Cell 2 and Cell 3 are the aggressor cells. The downlink physical channel setup is according to Annex C.3.2 for each of Cell 1, Cell 2 and Cell 3, respectively. The CRS assistance information [7] is provided and includes Cell 2 and Cell 3.

**Table 8.5.2.2.7-1: Test Parameters for PHICH**

Parameter	Unit	Cell 1	Cell 2	Cell 3	
Uplink downlink configuration		1	1	1	
Special subframe configuration		4	4	4	
Downlink power allocation	PDCCH_RA	dB	-3	-3	-3
	OCNG_RA	dB	-3	N/A	N/A
	PHICH_RA	dB	-3	N/A	N/A
	PCFICH_RB	dB	-3	-3	-3
	PDCCH_RB	dB	-3	-3	-3
Cell-specific reference signals		Antenna ports 0,1	Antenna ports 0,1	Antenna ports 0,1	
	$N_{oc}$ at antenna port	dBm/15kHz	-98	-98	-98
$\hat{E}_s/N_{oc}$	dB	N/A	13.91	3.34	
$BW_{channel}$	MHz	10	10	10	
Cyclic Prefix		Normal	Normal	Normal	
Cell ID		0	6	1	
Subframe Configuration		Non-MBSFN	Non-MBSFN	Non-MBSFN	
Number of control OFDM symbols		1	1	1	
PHICH Ng (Note 1)		1	N/A	N/A	
PHICH duration		Normal	N/A	N/A	
Interference model		N/A	As specified in clause B.7.1	As specified in clause B.7.1	
Unused RE-s and PRB-s (Note 2)		OCNG	OCNG	OCNG	
Time offset to cell 1	us	N/A	2	3	
Frequency offset to cell 1	Hz	N/A	200	300	

Note 1: According to Clause 6.9 in TS 36.211 [4].  
Note 2: For Cell 2 and Cell 3 unused RE-s and PRB-s do not include control region REs.



**Table 8.5.2.2.7-2: Minimum performance PHICH for Enhanced Downlink Control Channel Performance Requirement Type B**

Test Number	Reference Channel	OCNG Pattern			Propagation Conditions (Note 1)			Antenna Configuration and Correlation Matrix (Note 2)	Reference Value	
		Cell 1	Cell 2	Cell 3	Cell 1	Cell 2	Cell 3		Pm-an (%)	SNR (dB) (Note 3)
1	R.19	OP.1 TDD	OP.1 TDD	OP.1 TDD	EPA5	EPA5	EPA5	2x2 Low	0.1	14.0

Note 1: The propagation conditions for Cell 1, Cell 2 and Cell 3 are statistically independent.  
Note 2: The correlation matrix and antenna configuration apply for Cell 1, Cell 2 and Cell 3.  
Note 3: SNR corresponds to  $\hat{E}_s/N_{oc2}$  of Cell 1 as defined in clause 8.1.1.

### 8.5.2.2.8 Enhanced Downlink Control Channel Performance Requirement Type B - 2 Tx Antenna Ports with Non-Colliding CRS Dominant Interferer

For the parameters specified in Table 8.5.2-1 and Table 8.5.2.2.8-1, the average probability of a miss-detecting ACK for NACK (Pm-an) shall be below the specified value in Table 8.5.2.2.8-2. The purpose of this test is to verify the PHICH performance with 2 transmit antennas when the serving cell PHICH transmission is interfered by two interfering cells with the dominant interferer having the non-colliding CRS pattern and applying interference model defined in clause B.7.1. In Table 8.5.2.2.8-1, Cell 1 is the serving cell, and Cell 2 and Cell 3 are the aggressor cells. The downlink physical channel setup is according to Annex C.3.2 for each of Cell 1, Cell 2 and Cell 3, respectively. The CRS assistance information [7] is provided and includes Cell 2 and Cell 3.

**Table 8.5.2.2.8-1: Test Parameters for PHICH**

Parameter	Unit	Cell 1	Cell 2	Cell 3	
Uplink downlink configuration		1	1	1	
Special subframe configuration		4	4	4	
Downlink power allocation	PDCCH_RA	dB	-3	-3	-3
	OCNG_RA	dB	-3	N/A	N/A
	PHICH_RA	dB	-3	N/A	N/A
	PCFICH_RB	dB	-3	-3	-3
	PDCCH_RB	dB	-3	-3	-3
	dB	-3	N/A	N/A	
Cell-specific reference signals		Antenna ports 0,1	Antenna ports 0,1	Antenna ports 0,1	
$N_{oc}$ at antenna port	dBm/15kHz		-98		
$\hat{E}_s/N_{oc}$	dB	N/A	13.91	3.34	
$BW_{channel}$	MHz	10	10	10	
Cyclic Prefix		Normal	Normal	Normal	
Cell ID		0	1	6	
Subframe Configuration		Non-MBSFN	Non-MBSFN	Non-MBSFN	
Number of control OFDM symbols		1	1	1	
PHICH Ng (Note 1)		1	N/A	N/A	
PHICH duration		Normal	N/A	N/A	
Interference model		N/A	As specified in clause B.7.1	As specified in clause B.7.1	
Unused RE-s and PRB-s (Note 2)		OCNG	OCNG	OCNG	
Time offset to cell 1	us	N/A	2	3	
Frequency offset to cell 1	Hz	N/A	200	300	

Note 1: According to Clause 6.9 in TS 36.211 [4].  
Note 2: For Cell 2 and Cell 3 unused RE-s and PRB-s do not include control region REs.

**Table 8.5.2.2.8-2: Minimum performance PHICH for Enhanced Downlink Control Channel Performance Requirement Type B**

Test Number	Reference Channel	OCNG Pattern			Propagation Conditions (Note 1)			Antenna Configuration and Correlation Matrix (Note 2)	Reference Value	
		Cell 1	Cell 2	Cell 3	Cell 1	Cell 2	Cell 3		Pm-an (%)	SNR (dB) (Note 3)
1	R.19	OP.1 TDD	OP.1 TDD	OP.1 TDD	EPA5	EPA5	EPA5	2x2 Low	0.1	15.5

Note 1: The propagation conditions for Cell 1, Cell 2 and Cell 3 are statistically independent.  
Note 2: The correlation matrix and antenna configuration apply for Cell 1, Cell 2 and Cell 3.  
Note 3: SNR corresponds to  $\bar{E}_s/N_{oc2}$  of Cell 1 as defined in clause 8.1.1.

## 8.6 Demodulation of PBCH

The receiver characteristics of the PBCH are determined by the probability of miss-detection of the PBCH (Pm-bch), which is defined as

$$P_{m-bch} = 1 - \frac{A}{B}$$

Where A is the number of correctly decoded MIB PDUs and B is the Number of transmitted MIB PDUs (Redundancy versions for the same MIB are not counted separately).

### 8.6.1 FDD

**Table 8.6.1-1: Test Parameters for PBCH**

Parameter		Unit	Single antenna port	Transmit diversity
Downlink power allocation	PBCH_RA	dB	0	-3
	PBCH_RB	dB	0	-3
$N_{oc}$ at antenna port		dBm/15kHz	-98	-98
Cyclic prefix			Normal	Normal
Cell ID			0	0

Note 1: as specified in Table 4.2-2 in TS 36.211 [4]  
Note 2: as specified in Table 4.2-1 in TS 36.211 [4]

#### 8.6.1.1 Single-antenna port performance

For the parameters specified in Table 8.6.1-1 the average probability of a miss-detecting PBCH (Pm-bch) shall be below the specified value in Table 8.6.1.1-1. The downlink physical setup is in accordance with Annex C.3.2.

**Table 8.6.1.1-1: Minimum performance PBCH**

Test number	Bandwidth	Reference Channel	Propagation Condition	Antenna configuration and correlation Matrix	Reference value	
					Pm-bch (%)	SNR (dB)
1	1.4 MHz	R.21	ETU70	1 x 2 Low	1	-6.1

## 8.6.1.2 Transmit diversity performance

### 8.6.1.2.1 Minimum Requirement 2 Tx Antenna Port

For the parameters specified in Table 8.6.1-1 the average probability of a miss-detected PBCH (Pm-bch) shall be below the specified value in Table 8.6.1.2.1-1. The downlink physical setup is in accordance with Annex C.3.2.

**Table 8.6.1.2.1-1: Minimum performance PBCH**

Test number	Bandwidth	Reference Channel	Propagation Condition	Antenna configuration and correlation Matrix	Reference value	
					Pm-bch (%)	SNR (dB)
1	1.4 MHz	R.22	EPA5	2 x 2 Low	1	-4.8

### 8.6.1.2.2 Minimum Requirement 4 Tx Antenna Port

For the parameters specified in Table 8.6.1-1 the average probability of a miss-detected PBCH (Pm-bch) shall be below the specified value in Table 8.6.1.2.2-1. The downlink physical setup is in accordance with Annex C.3.2.

**Table 8.6.1.2.2-1: Minimum performance PBCH**

Test number	Bandwidth	Reference Channel	Propagation Condition	Antenna configuration and correlation Matrix	Reference value	
					Pm-bch (%)	SNR (dB)
1	1.4 MHz	R.23	EVA5	4 x 2 Medium	1	-3.5

### 8.6.1.2.3 Minimum Requirement 2 Tx Antenna Port under Time Domain Measurement Resource Restriction with CRS Assistance Information

For the parameters specified in Table 8.6.1.2.3-1 and Table 8.6.1.2.3-2, the averaged probability of a miss-detected PBCH (Pm-bch) shall be below the specified value in Table 8.6.1.2.3-2. Cell 1 is the serving cell, and Cell 2 and Cell 3 are the aggressor cells. The downlink physical channel setup for Cell 1 is according to Annex C.3.2 and for Cell 2 and Cell 3 is according to Annex C.3.3, respectively. The CRS assistance information [7] including Cell 2 and Cell 3 is provided.

Table 8.6.1.2.3-1: Test Parameters for PBCH

Parameter		Unit	Cell 1	Cell 2	Cell 3
Downlink power allocation	PBCH_RA OCNG_RA	dB	-3	-3	-3
	PBCH_RB OCNG_RB	dB	-3	-3	-3
$N_{oc}$ at antenna port		dBm/15kHz	-98	N/A	N/A
$\hat{E}_s/N_{oc}$		dB	Reference Value in Table 8.6.1.2.3-2	4	2
BW <sub>Channel</sub>		MHz	1.4	1.4	1.4
Time Offset between Cells		μs	N/A	3	-1
Frequency shift between Cells		Hz	N/A	300	-100
Cell Id			0	126	1
ABS Pattern (Note 4)			N/A	01000000 01000000 01000000 01000000 01000000	01000000 01000000 01000000 01000000 01000000
Unused RE-s and PRB-s			OCNG	OCNG	OCNG
Cyclic prefix			Normal	Normal	Normal
<p>Note 1: The number of the CRS ports in Cell1, Cell2 and Cell 3 is the same.</p> <p>Note 2: SIB-1 will not be transmitted in Cell2 and Cell 3 in the test.</p> <p>Note 3: The PBCH transmission from Cell 1, Cell 2 and Cell 3 overlap. The same PBCH transmission redundancy version is used for Cell 1, Cell 2 and Cell 3.</p> <p>Note 4: ABS pattern as defined in [9]. PDSCH other than SIB1/paging and its associated PDCCH/PCFICH are transmitted in the serving cell subframe when the subframe is overlapped with the ABS subframe of aggressor cell and the subframe is available in the definition of the reference channel.</p>					

Table 8.6.1.2.3-2: Minimum performance PBCH

Test Number	Reference Channel	Propagation Conditions (Note 1)			Antenna Configuration and Correlation Matrix (Note 2)	Reference Value	
		Cell 1	Cell 2	Cell 3		Pm-bch (%)	SNR (dB) (Note 3)
1	R.22	ETU30	ETU30	ETU30	2x2 Low	1	-3.0
<p>Note 1: The propagation conditions for Cell 1, Cell 2 and Cell 3 are statistically independent.</p> <p>Note 2: The correlation matrix and antenna configuration apply for Cell 1, Cell 2 and Cell 3.</p> <p>Note 3: SNR corresponds to <math>\hat{E}_s/N_{oc}</math> of cell 1.</p>							

## 8.6.2 TDD

Table 8.6.2-1: Test Parameters for PBCH

Parameter		Unit	Single antenna port	Transmit diversity
Uplink downlink configuration (Note 1)			1	1
Special subframe configuration (Note 2)			4	4
Downlink power allocation	PBCH_RA	dB	0	-3
	PBCH_RB	dB	0	-3
$N_{oc}$ at antenna port		dBm/15kHz	-98	-98
Cyclic prefix			Normal	Normal
Cell ID			0	0
Note 1: as specified in Table 4.2-2 in TS 36.211 [4].				
Note 2: as specified in Table 4.2-1 in TS 36.211 [4].				

## 8.6.2.1 Single-antenna port performance

For the parameters specified in Table 8.6.2-1 the average probability of a miss-detected PBCH ( $P_{m-bch}$ ) shall be below the specified value in Table 8.6.2.1-1. The downlink physical setup is in accordance with Annex C.3.2.

Table 8.6.2.1-1: Minimum performance PBCH

Test number	Bandwidth	Reference Channel	Propagation Condition	Antenna configuration and correlation Matrix	Reference value	
					$P_{m-bch}$ (%)	SNR (dB)
1	1.4 MHz	R.21	ETU70	1 x 2 Low	1	-6.4

## 8.6.2.2 Transmit diversity performance

## 8.6.2.2.1 Minimum Requirement 2 Tx Antenna Port

For the parameters specified in Table 8.6.2-1 the average probability of a miss-detected PBCH ( $P_{m-bch}$ ) shall be below the specified value in Table 8.6.2.2.1-1. The downlink physical setup is in accordance with Annex C.3.2.

Table 8.6.2.2.1-1: Minimum performance PBCH

Test number	Bandwidth	Reference Channel	Propagation Condition	Antenna configuration and correlation Matrix	Reference value	
					$P_{m-bch}$ (%)	SNR (dB)
1	1.4 MHz	R.22	EPA5	2 x 2 Low	1	-4.8

## 8.6.2.2.2 Minimum Requirement 4 Tx Antenna Port

For the parameters specified in Table 8.6.2-1 the average probability of a miss-detected PBCH ( $P_{m-bch}$ ) shall be below the specified value in Table 8.6.2.2.2-1. The downlink physical setup is in accordance with Annex C.3.2.

Table 8.6.2.2.2-1: Minimum performance PBCH

Test number	Bandwidth	Reference Channel	Propagation Condition	Antenna configuration and correlation Matrix	Reference value	
					Pm-bch (%)	SNR (dB)
1	1.4 MHz	R.23	EVA5	4 x 2 Medium	1	-4.1

### 8.6.2.2.3 Minimum Requirement 2 Tx Antenna Port under Time Domain Measurement Resource Restriction with CRS Assistance Information

For the parameters specified in Table 8.6.2.2.3-1 and Table 8.6.2.2.3-2, the averaged probability of a miss-detected PBCH (Pm-bch) shall be below the specified value in Table 8.6.2.2.3-2. Cell 1 is the serving cell, and Cell 2 and Cell 3 are the aggressor cells. The downlink physical channel setup for Cell 1 is according to Annex C.3.2 and for Cell 2 and Cell 3 is according to Annex C3.3, respectively. The CRS assistance information [7] including Cell 2 and Cell 3 is provided.

Table 8.6.2.2.3-1: Test Parameters for PBCH

Parameter		Unit	Cell 1	Cell 2	Cell 3
Downlink power allocation	PBCH_RA OCNG_RA	dB	-3	-3	-3
	PBCH_RB OCNG_RB	dB	-3	-3	-3
$N_{oc}$ at antenna port		dBm/15kHz	-98	N/A	N/A
$\hat{E}_s/N_{oc}$		dB	Reference Value in Table 8.6.2.2.3-2	4	2
BW <sub>Channel</sub>		MHz	1.4	1.4	1.4
Time Offset between Cells		μs	N/A	3	-1
Frequency shift between Cells		Hz	N/A	300	-100
Cell Id			0	126	1
ABS Pattern (Note 4)			N/A	000000001 000000001	000000001 000000001
Unused RE-s and PRB-s			OCNG	OCNG	OCNG
Cyclic prefix			Normal	Normal	Normal
Note 1: The number of the CRS ports in Cell1, Cell2 and Cell 3 is the same.					
Note 2: SIB-1 will not be transmitted in Cell2 and Cell 3 in the test.					
Note 3: The PBCH transmission from Cell 1, Cell 2 and Cell 3 overlap. The same PBCH transmission redundancy version is used for Cell 1, Cell 2 and Cell 3.					
Note 4: ABS pattern as defined in [9]. PDSCH other than SIB1/paging and its associated PDCCH/PCFICH are transmitted in the serving cell subframe when the subframe is overlapped with the ABS subframe of aggressor cell and the subframe is available in the definition of the reference channel.					

Table 8.6.2.2.3-2: Minimum performance PBCH

Test Number	Reference Channel	Propagation Conditions (Note 1)			Antenna Configuration and Correlation Matrix (Note 2)	Reference Value	
		Cell 1	Cell 2	Cell 3		Pm-bch (%)	SNR (dB) (Note 3)
1	R.22	ETU30	ETU30	ETU30	2x2 Low	1	-3.0
Note 1: The propagation conditions for Cell 1, Cell 2 and Cell 3 are statistically independent.							
Note 2: The correlation matrix and antenna configuration apply for Cell 1, Cell 2 and Cell 3.							
Note 3: SNR corresponds to $\hat{E}_s/N_{oc}$ of cell 1.							

## 8.7 Sustained downlink data rate provided by lower layers

The purpose of the test is to verify that the Layer 1 and Layer 2 correctly process in a sustained manner the received packets corresponding to the maximum number of DL-SCH transport block bits received within a TTI for the UE category indicated. The sustained downlink data rate shall be verified in terms of the success rate of delivered PDCP SDU(s) by Layer 2. The test case below specifies the RF conditions and the required success rate of delivered TB by Layer 1 to meet the sustained data rate requirement. The size of the TB per TTI corresponds to the largest possible DL-SCH transport block for each UE category using the maximum number of layers for spatial multiplexing. Transmission modes 1 and 3 are used with radio conditions resembling a scenario where sustained maximum data rates are available.

Test case is selected according to table 8.7-1 depending on UE capability for CA and EPDCCH.

**Table 8.7-1: SDR test applicability**

	Single carrier UE not supporting EPDCCH	CA UE not supporting EPDCCH	Single carrier UE supporting EPDCCH	CA UE supporting EPDCCH
<b>FDD</b>	<b>8.7.1</b>	<b>8.7.1</b>	<b>8.7.3</b>	<b>8.7.1, 8.7.3</b>
<b>TDD</b>	<b>8.7.2</b>	<b>8.7.2</b>	<b>8.7.4</b>	<b>8.7.2, 8.7.4</b>

### 8.7.1 FDD (single carrier and CA)

The parameters specified in Table 8.7.1-1 are valid for all FDD tests unless otherwise stated.

**Table 8.7.1-1: Common Test Parameters (FDD)**

Parameter	Unit	Value
Cyclic prefix		Normal
Cell ID		0
Inter-TTI Distance		1
Number of HARQ processes per component carrier	Processes	8
Maximum number of HARQ transmission		4
Redundancy version coding sequence		{0,0,1,2} for 64QAM and 256QAM
Number of OFDM symbols for PDCCH per component carrier	OFDM symbols	1
Cross carrier scheduling		Not configured
Propagation condition		Static propagation condition No external noise sources are applied

For UE not supporting 256QAM, the requirements are specified in Table 8.7.1-3, with the addition of the parameters in Table 8.7.1-2 and the downlink physical channel setup according to Annex C.3.2. The test points are applied to UE category and bandwidth combination with maximum aggregated bandwidth as specified in Table 8.7.1-4. The TB success rate shall be sustained during at least 300 frames.

For UE supporting 256QAM, the requirements are specified in Table 8.7.1-6, with the addition of the parameters in Table 8.7.1-5 and the downlink physical channel setup according to Annex C.3.2. The test points are applied to UE category and bandwidth combination with maximum aggregated bandwidth as specified in Table 8.7.1-7, the TB success rate shall be sustained during at least 300 frames. For UE supporting 256QAM, the requirement in Table 8.7.1-3 is not applicable.

For UE supporting 256QAM and category 9/10 and category 13, the requirements are specified in both Table 8.7.1-3 and Table 8.7.1-6, with the addition of the parameters in Table 8.7.1-2 and in Table 8.7.1-5 respectively. The downlink physical channel setup according to Annex C.3.2. The test points are applied to UE category and bandwidth combination with maximum aggregated bandwidth as specified in Table 8.7.1-4 and in Table 8.7.1-7 for the category 9/10 and category 13, the TB success rate shall be sustained during at least 300 frames.

The test coverage for different number of component carriers is defined in 8.1.2.4.



**Table 8.7.1-2: test parameters for sustained downlink data rate (FDD 64QAM)**

Test	Bandwidth (MHz)	Transmission mode	Antenna configuration	Codebook subset restriction	Downlink power allocation (dB)			$\hat{E}_s$ at antenna port (dBm/15kHz)	Symbols for unused PRBs
					$\rho_A$	$\rho_B$	$\sigma$		
1	10	1	1 x 2	N/A	0	0	0	-85	OP.6 FDD
1A	10	1	1x1	N/A	0	0	0	-85	OP.6 FDD
1B	20	1	1x1	N/A	0	0	0	-85	OP.6 FDD
2	10	3	2 x 2	10	-3	-3	0	-85	OP.1 FDD
3,4,6	20	3	2 x 2	10	-3	-3	0	-85	OP.1 FDD
3A	10	3	2 x 2	10	-3	-3	0	-85	OP.1 FDD
3B, 4A	2x10	3	2 x 2	10	-3	-3	0	-85	OP.1 FDD
3C, 4B	15	3	2 x 2	10	-3	-3	0	-85	OP.1 FDD
6A	2x20	3	2 x 2	10	-3	-3	0	-85	OP.1 FDD
6B	10+15	3	2 x 2	10	-3	-3	0	-85	OP.1 FDD
6C	10+20	3	2 x 2	10	-3	-3	0	-85	OP.1 FDD
6D	15+20	3	2 x 2	10	-3	-3	0	-85	OP.1 FDD
6E	2x15	3	2 x 2	10	-3	-3	0	-85	OP.1 FDD
6F	15+5	3	2 x 2	10	-3	-3	0	-85	OP.1 FDD
6G	20+5	3	2 x 2	10	-3	-3	0	-85	OP.1 FDD
7	3x20	3	2 x 2	10	-3	-3	0	-85	OP.1 FDD
7A	15+20+20	3	2 x 2	10	-3	-3	0	-85	OP.1 FDD
7B	10+20+20	3	2 x 2	10	-3	-3	0	-85	OP.1 FDD
7C	15+15+20	3	2 x 2	10	-3	-3	0	-85	OP.1 FDD
7D	10+15+20	3	2 x 2	10	-3	-3	0	-85	OP.1 FDD
7E	10+10+20	3	2 x 2	10	-3	-3	0	-85	OP.1 FDD
7F	10+15+15	3	2 x 2	10	-3	-3	0	-85	OP.1 FDD
7G	5+10+20	3	2 x 2	10	-3	-3	0	-85	OP.1 FDD
7H	5+15+20	3	2 x 2	10	-3	-3	0	-85	OP.1 FDD
7I	5+10+10	3	2 x 2	10	-3	-3	0	-85	OP.1 FDD
7J	5+5+20	3	2 x 2	10	-3	-3	0	-85	OP.1 FDD
7K	3x10	3	2 x 2	10	-3	-3	0	-85	OP.1 FDD
7L	5+5+10	3	2 x 2	10	-3	-3	0	-85	OP.1 FDD
8	4x20	3	2 x 2	10	-3	-3	0	-85	OP.1 FDD
8A	20+20+20+10	3	2 x 2	10	-3	-3	0	-85	OP.1 FDD
8B	20+20+10+10	3	2 x 2	10	-3	-3	0	-85	OP.1 FDD

8C	20+20+10+5	3	2 x 2	10	-3	-3	0	-85	OP.1 FDD
8D	20+10+10+5	3	2 x 2	10	-3	-3	0	-85	OP.1 FDD
8E	15+3x20	3	2 x 2	10	-3	-3	0	-85	OP.1 FDD
8F	2x15+2x20	3	2 x 2	10	-3	-3	0	-85	OP.1 FDD
8G	10+15+2x20	3	2 x 2	10	-3	-3	0	-85	OP.1 FDD
8H	3x10+20	3	2 x 2	10	-3	-3	0	-85	OP.1 FDD
8I	2x5+2x20	3	2 x 2	10	-3	-3	0	-85	OP.1 FDD
8J	2x5+10+20	3	2 x 2	10	-3	-3	0	-85	OP.1 FDD
8K	4x10	3	2 x 2	10	-3	-3	0	-85	OP.1 FDD
9	5x20	3	2 x 2	10	-3	-3	0	-85	OP.1 FDD
9A	15+4x20	3	2 x 2	10	-3	-3	0	-85	OP.1 FDD
9B	10+4x20	3	2 x 2	10	-3	-3	0	-85	OP.1 FDD
9C	2x10+3x20	3	2 x 2	10	-3	-3	0	-85	OP.1 FDD
9D	5+10+3x20	3	2 x 2	10	-3	-3	0	-85	OP.1 FDD
9E	3x10+2x20	3	2 x 2	10	-3	-3	0	-85	OP.1 FDD
9F	4x10+20	3	2 x 2	10	-3	-3	0	-85	OP.1 FDD
10	6x20	3	2 x 2	10	-3	-3	0	-85	OP.1 FDD
11	7x20	3	2 x 2	10	-3	-3	0	-85	OP.1 FDD
NOTE 1: For CA test cases, PUCCH format 1b with channel selection is used to feedback ACK/NACK for Test 1-6E, and PUCCH format 3 is used to feedback ACK/NACK for Test 7-7G.									

**Table 8.7.1-3: Minimum requirement (FDD 64QAM)**

Test	Number of bits of a DL-SCH transport block received within a TTI	Measurement channel	Reference value
			TB success rate [%]
1	10296	R.31-1 FDD	95
1A	10296	R.31-1 FDD	95
1B	10296	R.31-1A FDD	95
2	25456	R.31-2 FDD	95
3	51024	R.31-3 FDD	95
3A	36696 (Note 2)	R.31-3A FDD	85
3B	25456	R.31-2 FDD	95
3C	51024	R.31-3C FDD	85
4	75376 (Note 3)	R.31-4 FDD	85
4A	36696 (Note 2)	R.31-3A FDD	85
4B	55056 (Note 5)	R.31-4B FDD	85
6	75376 (Note 3)	R.31-4 FDD	85
6A	75376 (Note 3)	R.31-4 FDD	85
6B	36696 (Note 2) for 10MHz CC 55056 for 15MHz CC	R.31-3A FDD for 10MHz CC R.31-5 FDD for 15MHz CC	85
6C	36696 (Note 2) for 10MHz CC 75376 (Note 3) for 20MHz CC	R.31-3A FDD for 10MHz CC R.31-4 FDD for 20MHz CC	85
6D	55056 for 15MHz CC 75376 (Note 3) for 20MHz CC	R.31-5 FDD for 15MHz CC R.31-4 FDD for 20MHz CC	85
6E	55056 (Note 5) for two 15MHz CCs	R.31-4B FDD for two 15MHz CCs	85
6F	55056 (Note 5) for 15MHz CC 18336 (Note 6) for 5MHz CC	R.31-5 FDD for 15MHz CC R.31-6 FDD for 5MHz CC	85
6G	75376 (Note 3) for 20MHz CC 18336 (Note 6) for 5MHz CC	R.31-4 FDD for 20MHz CC R.31-6 FDD for 5MHz CC	85
7	75376 (Note 3)	R.31-4 FDD	85
7A	55056 (Note 5) for 15MHz CC 75376 (Note 3) for 20MHz CC	R.31-5 FDD for 15MHz CC R.31-4 FDD for 20MHz CC	85
7B	36696 (Note 2) for 10MHz CC 75376 (Note 3) for 20MHz CC	R.31-3A FDD for 10MHz CC R.31-4 FDD for 20MHz CC	85
7C	55056 (Note 5) for 15MHz CC 75376 (Note 3) for 20MHz CC	R.31-5 FDD for 15MHz CC R.31-4 FDD for 20MHz CC	85
7D	36696 (Note 2) for 10MHz CC 55056 (Note 5) for 15MHz CC 75376 (Note 3) for 20MHz CC	R.31-3A FDD for 10MHz CC R.31-5 FDD for 15MHz CC R.31-4 FDD for 20MHz CC	85
7E	36696 (Note 2) for 10MHz CC 75376 (Note 3) for 20MHz CC	R.31-3A FDD for 10MHz CC R.31-4 FDD for 20MHz CC	85
7F	36696 (Note 2) for 10MHz CC 55056 (Note 5) for 15MHz CC	R.31-3A FDD for 10MHz CC R.31-5 FDD for 15MHz CC	85
7G	18336 (Note 6) for 5MHz CC 36696 (Note 2) for 10MHz CC 75376 (Note 3) for 20MHz CC	R.31-6 FDD for 5MHz CC R.31-3A FDD for 10MHz CC R.31-4 FDD for 20MHz CC	85
7H	18336 (Note 6) for 5MHz CC 55056 (Note 5) for 15MHz CC 75376 (Note 3) for 20MHz CC	R.31-6 FDD for 5MHz CC R.31-5 FDD for 15MHz CC R.31-4 FDD for 20MHz CC	85
7I	18336 (Note 6) for 5MHz CC 36696 (Note 2) for 10MHz CC	R.31-6 FDD for 5MHz CC R.31-3A FDD for 10MHz CC	85
7J	18336 (Note 6) for 5MHz CC 75376 (Note 3) for 20MHz CC	R.31-6 FDD for 5MHz CC R.31-4 FDD for 20MHz CC	85
7K	36696 (Note 2) for 10MHz CC	R.31-3A FDD for 10MHz CC	85
7L	18336 (Note 6) for 5MHz CC 36696 (Note 2) for 10MHz CC	R.31-6 FDD for 5MHz CC R.31-3A FDD for 10MHz CC	85
8E	55056 (Note 5) for 15MHz CC 75376 (Note 3) for 20MHz CC	R.31-5 FDD for 15MHz CC R.31-4 FDD for 20MHz CC	85
8F	55056 (Note 5) for 15MHz CC 75376 (Note 3) for 20MHz CC	R.31-5 FDD for 15MHz CC R.31-4 FDD for 20MHz CC	85
8G	36696 (Note 2) for 10MHz CC 55056 (Note 5) for 15MHz CC 75376 (Note 3) for 20MHz CC	R.31-3A FDD for 10MHz CC R.31-5 FDD for 15MHz CC R.31-4 FDD for 20MHz CC	85
8H	36696 (Note 2) for 10MHz CC 75376 (Note 3) for 20MHz CC	R.31-3A FDD for 10MHz CC R.31-4 FDD for 20MHz CC	85
8I	18336 (Note 6) for 5MHz CC 75376 (Note 3) for 20MHz CC	R.31-6 FDD for 5MHz CC R.31-4 FDD for 20MHz CC	85
8J	18336 (Note 6) for 5MHz CC 36696 (Note 2) for 10MHz CC 75376 (Note 3) for 20MHz CC	R.31-6 FDD for 5MHz CC R.31-3A FDD for 10MHz CC R.31-4 FDD for 20MHz CC	85

8K	36696 (Note 2) for 10MHz CC	R.31-3A FDD for 10MHz CC	85
8	75376 (Note 3)	R.31-4 FDD	85
8A	36696 (Note 2) for 10MHz CC 75376 (Note 3) for 20MHz CC	R.31-3A FDD for 10MHz CC R.31-4 FDD for 20MHz CC	85
8B	36696 (Note 2) for 10MHz CC 75376 (Note 3) for 20MHz CC	R.31-3A FDD for 10MHz CC R.31-4 FDD for 20MHz CC	85
8C	18336 (Note 6) for 5MHz CC 36696 (Note 2) for 10MHz CC 75376 (Note 3) for 20MHz CC	R.31-6 FDD for 5MHz CC R.31-3A FDD for 10MHz CC R.31-4 FDD for 20MHz CC	85
8D	18336 (Note 6) for 5MHz CC 36696 (Note 2) for 10MHz CC 75376 (Note 3) for 20MHz CC	R.31-6 FDD for 5MHz CC R.31-3A FDD for 10MHz CC R.31-4 FDD for 20MHz CC	85
9	75376 (Note 3)	R.31-4 FDD	85
9A	55056 (Note 5) for 15MHz CC 75376 (Note 3) for 20MHz CC	R.31-5 FDD for 15MHz CC R.31-4 FDD for 20MHz CC	85
9B	36696 (Note 2) for 10MHz CC 75376 (Note 3) for 20MHz CC	R.31-3A FDD for 10MHz CC R.31-4 FDD for 20MHz CC	85
9C	36696 (Note 2) for 10MHz CC 75376 (Note 3) for 20MHz CC	R.31-3A FDD for 10MHz CC R.31-4 FDD for 20MHz CC	85
9D	18336 (Note 6) for 5MHz CC 36696 (Note 2) for 10MHz CC 75376 (Note 3) for 20MHz CC	R.31-6 FDD for 5MHz CC R.31-3A FDD for 10MHz CC R.31-4 FDD for 20MHz CC	85
9E	36696 (Note 2) for 10MHz CC 75376 (Note 3) for 20MHz CC	R.31-3A FDD for 10MHz CC R.31-4 FDD for 20MHz CC	85
9F	36696 (Note 2) for 10MHz CC 75376 (Note 3) for 20MHz CC	R.31-3A FDD for 10MHz CC R.31-4 FDD for 20MHz CC	85
10	75376 (Note 3)	R.31-4 FDD	85
11	75376 (Note 3)	R.31-4 FDD	85
Note 1:	For 2 layer transmissions, 2 transport blocks are received within a TTI.		
Note 2:	35160 bits for sub-frame 5.		
Note 3:	71112 bits for sub-frame 5.		
Note 4:	The TB success rate is defined as $TB\ success\ rate = 100\% \cdot N_{DL\_correct\_rx} / (N_{DL\_newtx} + N_{DL\_retx})$ , where $N_{DL\_newtx}$ is the number of newly transmitted DL transport blocks, $N_{DL\_retx}$ is the number of retransmitted DL transport blocks, and $N_{DL\_correct\_rx}$ is the number of correctly received DL transport blocks.		
Note 5:	52752bits for sub-frame 5.		
Note 6:	15840bits for sub-frame 0.		

**Table 8.7.1-4: Test points for sustained data rate (FRC 64QAM)**

CA config	Maximum supported Bandwidth/ Bandwidth combination (MHz)	Cat. 1	Cat. 1bis	Cat. 2	Cat. 3	Cat. 4	Cat. 6,7	Cat. 9,10	Cat 11, 12	DL Cat. 15
									DL Cat. 11,12	
Single carrier	10	1	1A	2	3A	3A	-	-	-	-
	15	-	-	-	3C	4B	-	-	-	-
	20	-	1B	-	3	4	6	-	-	-
CA with 2CCs	10+10	-	-	-	3B	4A	4A	4A	-	-
	10+15	-	-	-	3B	4A	6B	6B	-	-
	10+20	-	-	-	3B	4A	6C	6C	-	-
	15+15	-	-	-	3B	4A	6E	6E	-	-
	15+5	-	-	-	3B	4A	6F	6F	-	-
	20+5	-	-	-	3	4	6G	6G	-	-
	15+20	-	-	-	3B	4A	6D	6D	-	-
20+20	-	-	-	3B or 3 (Note 4)	4A or 4 (Note 4)	6A	6A	-	-	
CA with 3CCs	3x20	-	-	-	-	-	6A	7	7	-
	15+20+20	-	-	-	-	-	6A	7A	7A	-
	10+20+20	-	-	-	-	-	6A	7B	7B	-
	15+15+20	-	-	-	-	-	6D	7C	7C	-
	10+15+20	-	-	-	-	-	6D	7D	7D	-
	10+10+20	-	-	-	-	-	7E	7E	7E	-
	10+15+15	-	-	-	-	-	7F	7F	7F	-
	5+10+20	-	-	-	-	-	7G	7G	7G	-
	5+15+20	-	-	-	-	-	7H	7H	7H	-
	5+10+10	-	-	-	-	-	7I	7I	7I	-
	5+5+20	-	-	-	-	-	7J	7J	7J	-
3x10	-	-	-	-	-	7K	7K	7K	-	
5+5+10	-	-	-	-	-	7L	7L	7L	-	
CA with 4CCs	4x20	-	-	-	-	-	-	7	8	8
	20+20+20+10	-	-	-	-	-	-	7	8A	8A
	20+20+10+10	-	-	-	-	-	-	8B	8B	8B
	20+20+10+5	-	-	-	-	-	-	8C	8C	8C
	20+10+10+5	-	-	-	-	-	-	8D	8D	8D
	15+3x20	-	-	-	-	-	-	8E	8E	8E
	2x15+2x20	-	-	-	-	-	-	8F	8F	8F
	10+15+2x20	-	-	-	-	-	-	8G	8G	8G
	3x10+20	-	-	-	-	-	-	8H	8H	8H
	2x5+2x20	-	-	-	-	-	-	8I	8I	8I
	2x5+10+20	-	-	-	-	-	-	8J	8J	8J
4x10	-	-	-	-	-	-	8K	8K	8K	
CA with 5CCs	5x20	-	-	-	-	-	-	-	8	9
	15+4x20	-	-	-	-	-	-	-	-	10
	10+4x20	-	-	-	-	-	-	-	-	11
	2x10+3x20	-	-	-	-	-	-	-	-	12
	5+10+3x20	-	-	-	-	-	-	-	-	13
3x10+2x20	-	-	-	-	-	-	-	-	14	
CA with 6CCs	6x20	-	-	-	-	-	-	-	10	10
CA with 7CCs	7x20	-	-	-	-	-	-	-	11	11
Note 1:	Void.									
Note 2:	For non-CA UE, test is selected for maximum supported bandwidth.									
Note 3:	Void.									
Note 4:	If the intra-band contiguous CA is the only CA configuration supported by category 3 or 4 UE, the single carrier test is selected, i.e., Test 3 for UE category 3 and Test 4 for UE category 4. Otherwise, Test 3B applies for category 3 UE and Test 4A applies for category 4 UE.									
Note 5:	The applicability of requirements for different CA configurations and bandwidth combination sets is defined in 8.1.2.3.									
Note 6:	If DL category is signalled by the UE under test, then select the test point according to UE DL Category. Otherwise, select the test point according to the UE category signalled.									





**Table 8.7.1-5: test parameters for sustained downlink data rate (FDD 256QAM)**

Test	Bandwidth (MHz)	Transmission mode	Antenna configuration	Codebook subset restriction	Downlink power allocation (dB)			$\hat{E}_s$ at antenna port (dBm/15kHz)	Symbols for unused PRBs
					$\rho_A$	$\rho_B$	$\sigma$		
1	20	3	2 x 2	10	-3	-3	0	-85	OP.1 FDD
2	2x15	3	2 x 2	10	-3	-3	0	-85	OP.1 FDD
2A	15+5	3	2 x 2	10	-3	-3	0	-85	OP.1 FDD
3	10+15	3	2 x 2	10	-3	-3	0	-85	OP.1 FDD
3A	20+5	3	2 x 2	10	-3	-3	0	-85	OP.1 FDD
4	10+20	3	2 x 2	10	-3	-3	0	-85	OP.1 FDD
6	15+20	3	2 x 2	10	-3	-3	0	-85	OP.1 FDD
7	2x20	3	2 x 2	10	-3	-3	0	-85	OP.1 FDD
8	3x20	3	2 x 2	10	-3	-3	0	-85	OP.1 FDD
9	15+20+20	3	2 x 2	10	-3	-3	0	-85	OP.1 FDD
10	10+20+20	3	2 x 2	10	-3	-3	0	-85	OP.1 FDD
11	15+15+20	3	2 x 2	10	-3	-3	0	-85	OP.1 FDD
12	10+15+20	3	2 x 2	10	-3	-3	0	-85	OP.1 FDD
13	10+10+20	3	2 x 2	10	-3	-3	0	-85	OP.1 FDD
14	10+15+15	3	2 x 2	10	-3	-3	0	-85	OP.1 FDD
15	5+10+20	3	2 x 2	10	-3	-3	0	-85	OP.1 FDD
15A	5+15+20	3	2 x 2	10	-3	-3	0	-85	OP.1 FDD
15B	5+10+10	3	2 x 2	10	-3	-3	0	-85	OP.1 FDD
15C	5+5+20	3	2 x 2	10	-3	-3	0	-85	OP.1 FDD
15D	3x10	3	2 x 2	10	-3	-3	0	-85	OP.1 FDD
15E	5+5+10	3	2 x 2	10	-3	-3	0	-85	OP.1 FDD
16	4x20	3	2 x 2	10	-3	-3	0	-85	OP.1 FDD
17	20+20+20+10	3	2 x 2	10	-3	-3	0	-85	OP.1 FDD
18	20+20+10+10	3	2 x 2	10	-3	-3	0	-85	OP.1 FDD
18A	20+20+10+5	3	2 x 2	10	-3	-3	0	-85	OP.1 FDD
18B	20+10+10+5	3	2 x 2	10	-3	-3	0	-85	OP.1 FDD
18C	15+3x20	3	2 x 2	10	-3	-3	0	-85	OP.1 FDD
18D	2x15+2x20	3	2 x 2	10	-3	-3	0	-85	OP.1 FDD
18E	10+15+2x20	3	2 x 2	10	-3	-3	0	-85	OP.1 FDD
18F	3x10+20	3	2 x 2	10	-3	-3	0	-85	OP.1 FDD
18G	2x5+2x20	3	2 x 2	10	-3	-3	0	-85	OP.1 FDD

18H	2x5+10+20	3	2 x 2	10	-3	-3	0	-85	OP.1 FDD
18I	4x10	3	2 x 2	10	-3	-3	0	-85	OP.1 FDD
19	5x20	3	2 x 2	10	-3	-3	0	-85	OP.1 FDD
19A	15+4x20	3	2 x 2	10	-3	-3	0	-85	OP.1 FDD
19B	10+4x20	3	2 x 2	10	-3	-3	0	-85	OP.1 FDD
19C	2x10+3x20	3	2 x 2	10	-3	-3	0	-85	OP.1 FDD
19D	5+10+3x20	3	2 x 2	10	-3	-3	0	-85	OP.1 FDD
19E	3x10+2x20	3	2 x 2	10	-3	-3	0	-85	OP.1 FDD
19F	4x10+20	3	2 x 2	10	-3	-3	0	-85	OP.1 FDD
20	6x20	3	2 x 2	10	-3	-3	0	-85	OP.1 FDD
21	7x20	3	2 x 2	10	-3	-3	0	-85	OP.1 FDD
Note 1: For CA test cases, PUCCH format 3 is used to feedback ACK/NACK.									

**Table 8.7.1-6: Minimum requirement (FDD 256QAM)**

Test	Measurement channel	Reference value
		TB success rate [%]
1	R.68 FDD	85
2	R.68-1 FDD	85
2A	R.68-1 FDD for 15MHz CC R.68-3 FDD for 5MHz CC	85
3	R.68-2 FDD for 10MHz CC R.68-1 FDD for 15MHz CC	85
3A	R.68 FDD for 20MHz CC R.68-3 FDD for 5MHz CC	85
4	R.68-2 FDD for 10MHz CC R.68 FDD for 20MHz CC	85
6	R.68-1 FDD for 15MHz CC R.68 FDD for 20MHz CC	85
7	R.68 FDD	85
8	R.68 FDD	85
9	R.68-1 FDD for 15MHz CC R.68 FDD for 20MHz CC	85
10	R.68-2 FDD for 10MHz CC R.68 FDD for 20MHz CC	85
11	R.68-1 FDD for 15MHz CC R.68 FDD for 20MHz CC	85
12	R.68-2 FDD for 10MHz CC R.68-1 FDD for 15MHz CC R.68 FDD for 20MHz CC	85
13	R.68-2 FDD for 10MHz CC R.68 FDD for 20MHz CC	85
14	R.68-2 FDD for 10MHz CC R.68-1 FDD for 15MHz CC	85
15	R.68-3 FDD for 5MHz CC R.68-2 FDD for 10MHz CC R.68 FDD for 20MHz CC	85
15A	R.68-3 FDD for 5MHz CC R.68-1 FDD for 15MHz CC R.68 FDD for 20MHz CC	85
15B	R.68-3 FDD for 5MHz CC R.68-2 FDD for 10MHz CC	85
15C	R.68-3 FDD for 5MHz CC R.68 FDD for 20MHz CC	85
15D	R.68-2 FDD for 10MHz CC	85
15E	R.68-3 FDD for 5MHz CC R.68-2 FDD for 10MHz CC	85
16	R.68 FDD	85
17	R.68-2 FDD for 10MHz CC R.68 FDD for 20MHz CC	85
18	R.68-2 FDD for 10MHz CC R.68 FDD for 20MHz CC	85
18A	R.68-3 FDD for 5MHz CC R.68-2 FDD for 10MHz CC R.68 FDD for 20MHz CC	85
18B	R.68-3 FDD for 5MHz CC R.68-2 FDD for 10MHz CC R.68 FDD for 20MHz CC	85
18C	R.68-1 FDD for 15MHz CC R.68 FDD for 20MHz CC	85
18D	R.68-1 FDD for 15MHz CC R.68 FDD for 20MHz CC	85
18E	R.68-2 FDD for 10MHz CC R.68-1 FDD for 15MHz CC R.68 FDD for 20MHz CC	85
18F	R.68-2 FDD for 10MHz CC R.68 FDD for 20MHz CC	85
18G	R.68-3 FDD for 5MHz CC R.68 FDD for 20MHz CC	85
18H	R.68-3 FDD for 5MHz CC R.68-2 FDD for 10MHz CC R.68 FDD for 20MHz CC	85

18I	R.68-2 FDD for 10MHz CC	85
19	R.68 FDD	85
19A	R.68-1 FDD for 15MHz CC R.68 FDD for 20MHz CC	85
19B	R.68-2 FDD for 10MHz CC R.68 FDD for 20MHz CC	85
19C	R.68-2 FDD for 10MHz CC R.68 FDD for 20MHz CC	85
19D	R.68-3 FDD for 5MHz CC R.68-2 FDD for 10MHz CC R.68 FDD for 20MHz CC	85
19E	R.68-2 FDD for 10MHz CC R.68 FDD for 20MHz CC	85
19F	R.68-2 FDD for 10MHz CC R.68 FDD for 20MHz CC	85
20	R.68 FDD	85
21	R.68 FDD	85
Note 1:	For 2 layer transmissions, 2 transport blocks are received within a TTI.	
Note 2:	The TB success rate is defined as TB success rate = $100\% \cdot N_{DL\_correct\_rx} / (N_{DL\_newtx} + N_{DL\_retx})$ , where $N_{DL\_newtx}$ is the number of newly transmitted DL transport blocks, $N_{DL\_retx}$ is the number of retransmitted DL transport blocks, and $N_{DL\_correct\_rx}$ is the number of correctly received DL transport blocks.	

Table 8.7.1-7: Test points for sustained data rate (FRC 256QAM)

CA config	Maximum supported Bandwidth/ Bandwidth combination (MHz)	Cat. 11, 12	DL Cat. 13	DL Cat. 15	DL Cat. 16		
		DL Cat. 11, 12					
Single carrier	20	-	1	-	-		
CA with 2CCs	2x15	2	2	-	-		
	15+5	2A	2A	-	-		
	10+15	3	3	-	-		
	20+5	3A	3A	-	-		
	10+20	4	4	-	-		
	15+20	6	6	-	-		
CA with 3CCs	20+20	7	7	-	-		
	3x20	8	7	8	-		
	15+20+20	9	7	9	-		
	10+20+20	10	7	10	-		
	15+15+20	11	6	11	-		
	10+15+20	12	6	12	-		
	10+10+20	13	13	13	-		
	10+15+15	14	14	14	-		
	5+10+20	15	15	15	-		
	5+15+20	15A	15A	15A	-		
	5+10+10	15B	15B	15B	-		
	5+5+20	15C	15C	15C	-		
CA with 4CCs	3x10	15D	15D	15D	-		
	5+5+10	15E	15E	15E	-		
	4x20	8	-	16	16		
	20+20+20+10	8	-	17	17		
	20+20+10+10	18	-	18	18		
	20+20+10+5	18A	-	18A	18A		
	20+10+10+5	18B	-	18B	18B		
	15+3x20	18C	-	18C	18C		
	2x15+2x20	18D	-	18D	18D		
	10+15+2x20	18E	-	18E	18E		
	3x10+20	18F	-	18F	18F		
CA with 5CCs	2x5+2x20	18G	-	18G	18G		
	2x5+10+20	18H	-	18H	18H		
	4x10	18I	-	18I	18I		
	5x20	-	-	16	19		
	15+4x20				20		
	10+4x20				21		
	2x10+3x20				22		
5+10+3x20				23			
3x10+2x20				24			
4x10+20				25			
CA with 6CCs	6x20	-	-	-	20		
CA with 7CCs	7x20	-	-	-	21		

NOTE 1: If DL category is signalled by the UE under test, then select the test point according to UE DL Category. Otherwise, select the test point according to the UE category signalled.

## 8.7.2 TDD (single carrier and CA)

The parameters specified in Table 8.7.2-1 are valid for all TDD tests unless otherwise stated.



**Table 8.7.2-1: Common Test Parameters (TDD)**

Parameter	Unit	Value
Special subframe configuration (Note 1)		4
Cyclic prefix		Normal
Cell ID		0
Inter-TTI Distance		1
Maximum number of HARQ transmission		4
Redundancy version coding sequence		{0,0,1,2} for 64QAM and 256QAM
Number of OFDM symbols for PDCCH per component carrier	OFDM symbols	1
Cross carrier scheduling		Not configured
Propagation condition		Static propagation condition No external noise sources are applied
Note 1: as specified in Table 4.2-1 in TS 36.211 [4].		

For UE not supporting 256QAM, the requirements are specified in Table 8.7.2-3, with the addition of the parameters in Table 8.7.2-2 and the downlink physical channel setup according to Annex C.3.2. The test points are applied to UE category and bandwidth combination with maximum aggregated bandwidth as specified in Table 8.7.2-4. The TB success rate shall be sustained during at least 300 frames.

For UE supporting 256QAM, the requirements are specified in Table 8.7.2-6, with the addition of the parameters in Table 8.7.2-5 and the downlink physical channel setup according to Annex C.3.2. The test points are applied to UE category and bandwidth combination with maximum aggregated bandwidth as specified in Table 8.7.2-7. The TB success rate shall be sustained during at least 300 frames. For UE supporting 256QAM, the requirement in Table 8.7.2-3 is not applicable.

For UE supporting 256QAM and category 9/10 and category 13, the requirements are specified in both Table 8.7.2-3 and Table 8.7.2-6, with the addition of the parameters in Table 8.7.2-2 and in Table 8.7.2-5 respectively. The downlink physical channel setup according to Annex C.3.2. The test points are applied to UE category and bandwidth combination with maximum aggregated bandwidth as specified in Table 8.7.2-4 and in Table 8.7.2-7 for the category 9/10 and category 13, the TB success rate shall be sustained during at least 300 frames.

The test coverage for different number of component carriers is defined in 8.1.2.4.

Table 8.7.2-2: test parameters for sustained downlink data rate (TDD 64QAM)

Test	Bandwidth h (MHz)	Transmission mode	Antenna configuration	Codebook subset restriction	Downlink power allocation (dB)			$\hat{E}_s$ at antenna port (dBm/15 kHz)	ACK/NACK feedback mode	Symbols for unused PRBs
					$\rho_A$	$\rho_B$	$\sigma$			
1	10	1	1 x 2	N/A	0	0	0	-85	Bundling	OP.6 TDD
1A	10	1	1x1	N/A	0	0	0	-85	Bundling	OP.6 TDD
1B	20	1	1x1	N/A	0	0	0	-85	Bundling	OP.6 TDD
2	10	3	2 x 2	10	-3	-3	0	-85	Bundling	OP.1 TDD
3	20	3	2 x 2	10	-3	-3	0	-85	Bundling	OP.1 TDD
3A	15	3	2 x 2	10	-3	-3	0	-85	Multiplexing	OP.2 TDD
4,6	20	3	2 x 2	10	-3	-3	0	-85	Multiplexing	OP.1 TDD
6A	2x20	3	2 x 2	10	-3	-3	0	-85	(Note 1)	OP.1 TDD
6B	20+15	3	2 x 2	10	-3	-3	0	-85	(Note 1)	OP.1 TDD
7	3x20	3	2 x 2	10	-3	-3	0	-85	(Note 2)	OP.1 TDD
7A	15+20+20	3	2 x 2	10	-3	-3	0	-85	(Note 2)	OP.1 TDD
8	4x20	3	2 x 2	10	-3	-3	0	-85	(Note 2)	OP.1 TDD
9	15+3x20	3	2 x 2	10	-3	-3	0	-85	(Note 2)	OP.1 TDD
10	5x20	3	2 x 2	10	-3	-3	0	-85	(Note 2)	OP.1 TDD
11	15+4x20	3	2 x 2	10	-3	-3	0	-85	(Note 2)	OP.1 TDD
12	6x20	3	2 x 2	10	-3	-3	0	-85	(Note 2)	OP.1 TDD
13	7x20	3	2 x 2	10	-3	-3	0	-85	(Note 2)	OP.1 TDD

Note 1: PUCCH format 1b with channel selection is used to feedback ACK/NACK.  
Note 2: PUCCH format 3 is used to feedback ACK/NACK.

Table 8.7.2-3: Minimum requirement (TDD 64QAM)

Test	Number of bits of a DL-SCH transport block received within a TTI for normal/special sub-frame	Measurement channel	Reference value
			TB success rate [%]
1	10296/0	R.31-1 TDD	95
1A	10296/0	R.31-1 TDD	95
1B	10296/0	R.31-1A TDD	95
2	25456/0	R.31-2 TDD	95
3	51024/0	R.31-3 TDD	95
3A	51024/0	R.31-3A TDD	85
4	75376/0 (Note 2)	R.31-4 TDD	85
6	75376/0 (Note 2)	R.31-4 TDD	85
6A	75376/0 (Note 2)	R.31-4 TDD	85
6B	55056/0 for 15MHz CC 75376/0 for 20MHz CC (Note 2)	R.31-5 TDD for 15MHz CC R.31-4 TDD for 20MHz CC	85
7	75376/0 (Note 2)	R.31-4 TDD	85
7A	55056/0 for 15MHz CC 75376/0 for 20MHz CC (Note 2)	R.31-5 TDD for 15MHz CC R.31-4 TDD for 20MHz CC	85
8	75376/0 (Note 2)	R.31-4 TDD	85
9	55056/0 for 15MHz CC 75376/0 for 20MHz CC (Note 2)	R.31-5 TDD for 15MHz CC R.31-4 TDD for 20MHz CC	85
10	75376/0 (Note 2)	R.31-4 TDD	85
11	55056/0 for 15MHz CC 75376/0 for 20MHz CC (Note 2)	R.31-5 TDD for 15MHz CC R.31-4 TDD for 20MHz CC	85
12	75376/0 (Note 2)	R.31-4 TDD	85
13	75376/0 (Note 2)	R.31-4 TDD	85

Note 1: For 2 layer transmissions, 2 transport blocks are received within a TTI.  
Note 2: 71112 bits for sub-frame 5.  
Note 3: The TB success rate is defined as TB success rate =  $100 \cdot N_{DL\_correct\_rx} / (N_{DL\_newtx} + N_{DL\_retr})$ , where  $N_{DL\_newtx}$  is the number of newly transmitted DL transport blocks,  $N_{DL\_retr}$  is the number of retransmitted DL transport blocks, and  $N_{DL\_correct\_rx}$  is the number of correctly received DL transport blocks.

Table 8.7.2-4: Test points for sustained data rate (FRC 64QAM)

CA config	Bandwidth/ Bandwidth combination (MHz)	Cat. 1	Cat. 1bis	Cat. 2	Cat. 3	Cat. 4	Cat. 6,7	Cat. 9, 10	Cat. 11, 12	DL Cat. 15
									DL Cat. 11, 12	
Single carrier	10	1	1A	2	-	-	-	-	-	-
	15	-	-	-	3A	3A	-	-	-	-
	20	-	1B	-	3	4	6	-	-	-
CA with 2CCs	20+20	-	-	--	3(Note 4)	4 (Note 4)	6A	6A	-	-
	15+20	-	-	-	3(Note 4)	4 (Note 4)	6B	6B	-	-
CA with 3 CCs	3x20	-	-	-	-	-	6A	7	7	-
	15+20+20	-	-	-	-	-	6A	7A	7A	-
CA with 4 CCs	4x20	-	-	-	-	-	-	7	8	8
	15+3x20	-	-	-	-	-	-	7	9	9
CA with 5 CCs	5x20									
	15+4x20									
CA with 6 CCs	6x20								12	12
CA with 7 CCs	7x20								13	13
<p>Note 1: If DL category is signalled by the UE under test, then select the test point according to UE DL Category. Otherwise, select the test point according to the UE category signalled.</p> <p>Note 2: For non-CA UE, test is selected for maximum supported bandwidth.</p> <p>Note 3: Void.</p> <p>Note 4: If the intra-band contiguous CA is the only CA configuration supported by category 3 or 4 UE, single carrier test is selected.</p> <p>Note 5: The applicability of requirements for different CA configurations and bandwidth combination sets is defined in 8.1.2.3.</p>										

Table 8.7.2-5: test parameters for sustained downlink data rate (TDD 256QAM)

Test	Bandwidth (MHz)	Transmission mode	Antenna configuration	Codebook subset restriction	Downlink power allocation (dB)			$\hat{E}_s$ at antenna port (dBm/15 kHz)	ACK/NACK feedback mode	Symbols for unused PRBs
					$\rho_A$	$\rho_B$	$\sigma$			
1	20	3	2 x 2	10	-3	-3	0	-85	Bundling	OP.1 TDD
2	15+20	3	2 x 2	10	-3	-3	0	-85	(Note 1)	OP.1 TDD
3	2x20	3	2 x 2	10	-3	-3	0	-85	(Note 1)	OP.1 TDD
4	3x20	3	2 x 2	10	-3	-3	0	-85	(Note 1)	OP.1 TDD
5	15+20+20	3	2 x 2	10	-3	-3	0	-85	(Note 1)	OP.1 TDD
6	4x20	3	2 x 2	10	-3	-3	0	-85	(Note 1)	OP.1 TDD
7	15+3x20	3	2 x 2	10	-3	-3	0	-85	(Note 1)	OP.1 TDD
8	5x20	3	2 x 2	10	-3	-3	0	-85	(Note 1)	OP.1 TDD
9	15+4x20	3	2 x 2	10	-3	-3	0	-85	(Note 1)	OP.1 TDD
10	6x20	3	2 x 2	10	-3	-3	0	-85	(Note 1)	OP.1 TDD
11	7x20	3	2 x 2	10	-3	-3	0	-85	(Note 1)	OP.1 TDD
Note 1: For CA test cases, PUCCH format 3 is used to feedback ACK/NACK.										

Table 8.7.2-6: Minimum requirement (TDD 256QAM)

Test	Measurement channel	Reference value
		TB success rate [%]
1	R.68 TDD	85
2	R.68-1 TDD for 15MHz CC R.68 TDD for 20MHz CC	85
3	R.68 TDD	85
4	R.68 TDD	85
5	R.68-1 TDD for 15MHz CC R.68 TDD for 20MHz CC	85
6	R.68 TDD	85
7	R.68-1 TDD for 15MHz CC R.68 TDD for 20MHz CC	85
8	R.68 TDD	85
9	R.68-1 TDD for 15MHz CC R.68 TDD for 20MHz CC	85
10	R.68 TDD	85
11	R.68 TDD	85

Note 1: For 2 layer transmissions, 2 transport blocks are received within a TTI.

Note 2: The TB success rate is defined as TB success rate =  $100\% \cdot N_{DL\_correct\_rx} / (N_{DL\_newtx} + N_{DL\_retr})$ , where  $N_{DL\_newtx}$  is the number of newly transmitted DL transport blocks,  $N_{DL\_retr}$  is the number of retransmitted DL transport blocks, and  $N_{DL\_correct\_rx}$  is the number of correctly received DL transport blocks.

Table 8.7.2-7: Test points for sustained data rate (FRC 256QAM)

CA config	Bandwidth/ Bandwidth combination (MHz)	Cat. 11, 12	DL Cat. 13	DL Cat. 15	DL Cat. 16		
		DL Cat. 11, 12					
Single carrier	20	-	1	-	-		
CA with 2CCs	15+20	2	2	-	-		
	2x20	3	3	-	-		
CA with 3 CCs	3x20	4	3	4	-		
	15+20+20	5	3	5	-		
CA with 4 CCs	4x20	4	-	6	6		
	15+3x20	5	-	7	7		
CA with 5 CCs	5x20				8		
	15+4x20				9		
CA with 6 CCs	6x20				10		
CA with 7 CCs	7x20				11		

### 8.7.3 FDD (EPDCCH scheduling)

The parameters specified in Table 8.7.3-1 are valid for all FDD tests unless otherwise stated.

Table 8.7.3-1: Common test parameters (FDD)

Parameter	Unit	Value
Cyclic prefix		Normal
Cell ID		0
Inter-TTI Distance		1
Number of HARQ processes per component carrier	Processes	8
Maximum number of HARQ transmission		4
Redundancy version coding sequence		{0,0,1,2} for 64QAM
Number of OFDM symbols for PDCCH per component carrier	OFDM symbols	1
Cross carrier scheduling		Not configured
Number of EPDCCH sets		1
EPDCCH transmission type		Localized
Number of PRB per EPDCCH set and EPDCCH PRB pair allocation		2 PRB pairs 10MHz BW: Resource blocks $n_{PRB} = 48, 49$ 15MHz BW: Resource blocks $n_{PRB} = 70, 71$ 20MHz BW: Resource blocks $n_{PRB} = 98, 99$
EPDCCH Starting Symbol		Derived from CFI (i.e. default behaviour)
ECCE Aggregation Level		2 ECCEs
Number of EREGs per ECCE		4
EPDCCH scheduling		EPDCCH candidate is randomly assigned in each subframe
EPDCCH precoder (Note 1)		Fixed PMI 0
EPDCCH monitoring SF pattern		1111111111 0000000000 1111111111 0000000000
Timing advance	$\mu$ s	100
Propagation condition		Static propagation condition No external noise sources are applied
Note 1: EPDCCH precoder parameters are defined for tests with 2 x 2 antenna configuration		

The requirements are specified in Table 8.7.3-3, with the addition of the parameters in Table 8.7.3-2 and the downlink physical channel setup according to Annex C.3.2. The test points are applied to UE category, CA capability and bandwidth combination with maximum aggregated bandwidth as specified in Table 8.7.3-4. The TB success rate shall be sustained during at least 300 frames.

Table 8.7.3-2: Test parameters for SDR test for PDSCH scheduled by EPDCCH (FDD)

Test	Bandwidth (MHz)	Transmission mode	Antenna configuration	Codebook subset restriction	Downlink power allocation (dB)				$\hat{E}_s$ at antenna port (dBm/15kHz)	Symbols for unused PRBs
					$\rho_A$	$\rho_B$	$\sigma$	$\delta$		
1	10	1	1 x 2	N/A	0	0	0	0	-85	OP.6 FDD
2	10	3	2 x 2	10	-3	-3	0	3	-85	OP.1 FDD
3,4,6	20	3	2 x 2	10	-3	-3	0	3	-85	OP.1 FDD
3A	10	3	2 x 2	10	-3	-3	0	3	-85	OP.1 FDD
3C, 4B	15	3	2 x 2	10	-3	-3	0	3	-85	OP.1 FDD

**Table 8.7.3-3: Minimum requirement (FDD)**

Test	Number of bits of a DL-SCH transport block received within a TTI	Measurement channel	Reference value
			TB success rate [%]
1	10296	R.31E-1 FDD	95
2	25456	R.31E-2 FDD	95
3	51024	R.31E-3 FDD	95
3A	36696 (Note 2)	R.31E-3A FDD	85
3C	51024	R.31E-3C FDD	85
4	75376 (Note 3)	R.31E-4 FDD	85
4B	55056 (Note 5)	R.31E-4B FDD	85
6	75376 (Note 3)	R.31E-4 FDD	85

Note 1: For 2 layer transmissions, 2 transport blocks are received within a TTI.  
Note 2: 35160 bits for sub-frame 5.  
Note 3: 71112 bits for sub-frame 5.  
Note 4: The TB success rate is defined as  $TB\ success\ rate = 100\% \cdot N_{DL\_correct\_rx} / (N_{DL\_newtx} + N_{DL\_retr})$ , where  $N_{DL\_newtx}$  is the number of newly transmitted DL transport blocks,  $N_{DL\_retr}$  is the number of retransmitted DL transport blocks, and  $N_{DL\_correct\_rx}$  is the number of correctly received DL transport blocks.  
Note 5: 52752 bits for sub-frame 5.

**Table 8.7.3-4: Test points for sustained data rate (FRC)**

CA config	Bandwidth (MHz)	Category 1	Category 2	Category 3	Category 4	Category 6	Category 7
Single carrier	10	1	2	3A	3A	-	-
	15	-	-	3C	4B	-	-
	20	-	-	3	4	6	6

Note 1: The test is selected for maximum supported bandwidth.

## 8.7.4 TDD (EPDCCH scheduling)

The parameters specified in Table 8.7.4-1 are valid for all TDD tests unless otherwise stated.

Table 8.7.4-1: Common test parameters (TDD)

Parameter	Unit	Value
Special subframe configuration (Note 1)		4
Cyclic prefix		Normal
Cell ID		0
Inter-TTI Distance		1
Maximum number of HARQ transmission		4
Redundancy version coding sequence		{0,0,1,2} for 64QAM
Number of OFDM symbols for PDCCH per component carrier	OFDM symbols	1
Cross carrier scheduling		Not configured
Number of EPDCCH sets		1
EPDCCH transmission type		Localized
Number of PRB per EPDCCH set and EPDCCH PRB pair allocation		2 PRB pairs 10MHz BW: Resource blocks $n_{PRB} = 48, 49$ 15MHz BW: Resource blocks $n_{PRB} = 70, 71$ 20MHz BW: Resource blocks $n_{PRB} = 98, 99$
EPDCCH Starting Symbol		Derived from CFI (i.e. default behaviour)
ECCE Aggregation Level		2 ECCEs
Number of EREGs per ECCE		4 for normal subframe and for special subframe
EPDCCH scheduling		EPDCCH candidate is randomly assigned in each subframe
EPDCCH precoder (Note 2)		Fixed PMI 0
EPDCCH monitoring SF pattern		UL-DL configuration 1: 1101111111 0000000000 UL-DL configuration 5: 1100111001 0000000000
Timing advance	$\mu\text{s}$	100
Propagation condition		Static propagation condition No external noise sources are applied
Note 1:	As specified in Table 4.2-1 in TS 36.211 [4].	
Note 2:	EPDCCH precoder parameters are defined for tests with 2 x 2 antenna configuration	

The requirements are specified in Table 8.7.4-3, with the addition of the parameters in Table 8.7.4-2 and the downlink physical channel setup according to Annex C.3.2. The test points are applied to UE category, CA capability and bandwidth combination with maximum aggregated bandwidth as specified in Table 8.7.4-4. The TB success rate shall be sustained during at least 300 frames.

Table 8.7.4-2: Test parameters for SDR test for PDSCH scheduled by EPDCCH (TDD)

Test	Bandwidth (MHz)	Transmission mode	Antenna configuration	Codebook subset restriction	Downlink power allocation (dB)				$\hat{E}_s$ at antenna port (dBm/15kHz)	Symbols for unused PRBs	ACK/NACK feedback mode
					$\rho_A$	$\rho_B$	$\sigma$	$\delta$			
1	10	1	1 x 2	N/A	0	0	0	0	-85	OP.6 TDD	Bundling
2	10	3	2 x 2	10	-3	-3	0	3	-85	OP.1 TDD	Bundling
3	20	3	2 x 2	10	-3	-3	0	3	-85	OP.1 TDD	Bundling
3A	15	3	2 x 2	10	-3	-3	0	3	-85	OP.2 TDD	Multiplexing
4,6	20	3	2 x 2	10	-3	-3	0	3	-85	OP.1 TDD	Multiplexing

Table 8.7.4-3: Minimum requirement (TDD)

Test	Number of bits of a DL-SCH transport block received within a TTI for normal/special sub-frame	Measurement channel	Reference value
			TB success rate [%]
1	10296/0	R.31E-1 TDD	95
2	25456/0	R.31E-2 TDD	95
3	51024/0	R.31E-3 TDD	95
3A	51024/0	R.31E-3A TDD	85
4	75376/0 (Note 2)	R.31E-4 TDD	85
6	75376/0 (Note 2)	R.31E-4 TDD	85

Note 1: For 2 layer transmissions, 2 transport blocks are received within a TTI.  
Note 2: 71112 bits for sub-frame 5.  
Note 3: The TB success rate is defined as TB success rate = 100% \*  $N_{DL\_correct\_rx} / (N_{DL\_newtx} + N_{DL\_retr})$ , where  $N_{DL\_newtx}$  is the number of newly transmitted DL transport blocks,  $N_{DL\_retr}$  is the number of retransmitted DL transport blocks, and  $N_{DL\_correct\_rx}$  is the number of correctly received DL transport blocks.

Table 8.7.4-4: Test points for sustained data rate (FRC)

CA config	Bandwidth/Bandwidth combination (MHz)	Category 1	Category 2	Category 3	Category 4	Category 6	Category 7
Single carrier	10	1	2	-	-	-	-
	15	-	-	3A	3A	-	-
	20	-	-	3	4	6	6

Note 1: The test is selected for maximum supported bandwidth.

## 8.7.5 TDD FDD CA

The parameters specified in Table 8.7.5-1 are valid for all TDD FDD CA tests unless otherwise stated.



Table 8.7.5-1: Common Test Parameters (TDD FDD CA)

Parameter	Unit	Value	
Uplink downlink configuration (Note 1) for TDD CC		1	
Special subframe configuration (Note 2) for TDD CC		4	
Downlink power allocation	$\rho_A$	dB	-3
	$\rho_B$	dB	-3
	$\sigma$	dB	0
Cyclic prefix		Normal	
Cell ID		0	
Inter-TTI Distance		1	
Maximum number of HARQ processes per component carrier	FDD PCell	Processes	8 for FDD and TDD CCs
	TDD PCell	Processes	11 for FDD CC; 7 for TDD CC
Maximum number of HARQ transmission		4	
Redundancy version coding sequence		{0,0,1,2} for 64QAM, 256QAM	
Number of OFDM symbols for PDCCH per component carrier	OFDM symbols	1	
Cross carrier scheduling		Not configured	
Propagation condition		Static propagation condition No external noise sources are applied	
Transmission mode		TM3	
Codebook subset restriction		10	
Antenna configuration		2 x 2	
$\hat{E}_s$ at antenna port (dBm/15kHz)		-85	
Symbols for unused PRBs		OP.1 FDD for FDD CC, OP.1 TDD for TDD CC	
ACK/NACK feedback mode		PUCCH format 3	
Downlink HARQ-ACK timing	FDD PCell		As specified in Clause 7.3.3 in TS36.213 [6]
	TDD PCell		As specified in Clause 7.3.4 in TS36.213 [6]
Note 1:	as specified in Table 4.2-2 in TS 36.211 [4].		
Note 2:	as specified in Table 4.2-1 in TS 36.211 [4].		

### 8.7.5.1 Minimum Requirement FDD PCell

For UE not supporting 256QAM, the requirements for TDD FDD CA with FDD PCell are specified in Table 8.7.5.1-1 with the additional parameters specified in Table 8.7.5-1, and the downlink physical channel setup according to Annex C.3.2. The test points are applied to UE category and bandwidth combination with maximum aggregated bandwidth as specified in Table 8.7.5.1-2. The TB success rate shall be sustained during at least 300 frames.

For UE supporting 256QAM, the requirements for TDD FDD CA with FDD PCell are specified in Table 8.7.5.1-3 with the additional parameters specified in Table 8.7.5-1, and the downlink physical channel setup according to Annex C.3.2. The test points are applied to UE category or UE DL category, and bandwidth combination with the maximum aggregated bandwidth as specified in Table 8.7.5.1-4. The TB success rate shall be sustained during at least 300 frames. For UE supporting 256QAM, the requirement in Table 8.7.5.1-1 is not applicable.

The applicability of the requirements are specified in Clause 8.1.2.3B. The test coverage for different number of component carriers is defined in 8.1.2.4.

**Table 8.7.5.1-1: test parameters for sustained downlink data rate (TDD FDD CA 64QAM)**

Test number	Bandwidth (MHz)			Number of bits of a DL-SCH transport block received within a TTI (for normal/special subframe for TDD, except for subframe #5)		Measurement channel		Reference value
	Total	FDD CC	TDD CC	FDD CC	TDD CC	FDD CC	TDD CC	TB success rate [%]
1	2x20	20	20	75376	75376/0	R.31-4 FDD	R.31-4 TDD	85
2	10+20	10	20	36696	75376/0	R.31-3A FDD	R.31-4 TDD	85
2A	15+20	15	20	55056	75376/0	R.31-5 FDD	R.31-4 TDD	85
3	10+10	10	10	36696	36696/0	R.31-3A FDD	R.31-6 TDD	85
4	3x20	20	2x20	75376	75376/0	R.31-4 FDD	R.31-4 TDD	85
5	15+20+20	15	2x20	55056	75376/0	R.31-5 FDD	R.31-4 TDD	85
6	10+20+20	10	2x20	36696	75376/0	R.31-3A FDD	R.31-4 TDD	85
7	3x20	2x20	20	75376	75376/0	R.31-4 FDD	R.31-4 TDD	85
8	20+20+15	20+15	20	75376 for 20MHz CC 55056 for 15MHz CC	75376/0	R.31-4 FDD for 20MHz CC, R.31-5 FDD for 15MHz CC	R.31-4 TDD	85
9	20+20+10	20+10	20	75376 for 20MHz CC 36696 for 10MHz CC	75376/0	R.31-4 FDD for 20MHz CC, R.31-3A FDD for 10MHz CC	R.31-4 TDD	85
9A	20+10+10	2x10	20	36696	75376/0	R.31-3A	R.31-4 TDD	85
9B	10+15+20	10	15+20	36696	75376/0 for 20MHz CC 55056/0 for 15MHz CC	R.31-3A FDD	R.31-5 TDD for 15MHz CC R.31-4 TDD for 20MHz CC	85
9C	10+15+20	10+15	20	36696 for 10MHz CC 55056 for 15MHz CC	75376/0	R.31-3A FDD for 10MHz CC R.31-5 FDD for 15MHz CC	R.31-4 TDD	85
10	4x20	20	3x20	75376	75376/0	R.31-4 FDD	R.31-4 TDD	85
11	4x20	2x20	2x20	75376	75376/0	R.31-4 FDD	R.31-4 TDD	85
12	3x20+15	20+15	2x20	75376 for 20MHz CC 55056 for 15MHz CC	75376/0	R.31-4 FDD for 20MHz CC, R.31-5 FDD for 15MHz CC	R.31-4 TDD	85
13	2x15+2x20	2x15	2x20	55056	75376/0	R.31-5 FDD	R.31-4 TDD	85
14	3x20+15	2x20+15	20	75376 for 20MHz CC 55056 for 15MHz CC	75376/0	R.31-4 FDD for 20MHz CC, R.31-5 FDD for 15MHz CC	R.31-4 TDD	85
15	2x15+2x20	2x15+20	20	75376 for 20MHz CC 55056 for 15MHz CC	75376/0	R.31-4 FDD for 20MHz CC, R.31-5 FDD for 15MHz CC	R.31-4 TDD	85
15A	3x20+10	2x20+10	20	75376 for 20MHz CC 36696 for 10MHz CC	75376/0	R.31-4 FDD for 20MHz CC, R.31-3A FDD for 10MHz CC	R.31-4 TDD	85
15B	4x20	3x20	20	75376	75376/0	R.31-4 FDD	R.31-4 TDD	85
15C	10+3x20	10	3x20	36696	75376/0	R.31-3A FDD	R.31-4 TDD	85
15D	2x10+2x20	2x10	2x20	36696	75376/0	R.31-3A FDD	R.31-4 TDD	85
15E	2x10+20+15	2x10	20+15	36696	75376/0 for 20MHz CC 55056/0 for 15MHz CC	R.31-3A FDD	R.31-5 TDD for 15MHz CC R.31-4 TDD for 20MHz CC	85

15F	10+3x20	10+20	2x20	75376 for 20MHz CC 36696 for 10MHz CC	75376/0	R.31-4 FDD for 20MHz CC, R.31-3A FDD for 10MHz CC	R.31-4 TDD	85
15G	10+15+2x20	10+15	2x20	36696 for 10MHz CC 55056 for 15MHz CC	75376/0	R.31-3A FDD for 10MHz CC R.31-5 FDD for 15MHz CC	R.31-4 TDD	85
15H	10+15+2x20	10+15+20	20	36696 for 10MHz CC 55056 for 15MHz CC 75376 for 20MHz CC	75376/0	R.31-3A FDD for 10MHz CC R.31-5 FDD for 15MHz CC R.31-4 FDD for 20MHz CC	R.31-4 TDD	85
16	4x20+15	2x20+15	2x20	75376 for 20MHz CC 55056 for 15MHz CC	75376/0	R.31-4 FDD for 20MHz CC, R.31-5 FDD for 15MHz CC	R.31-4 TDD	85
17	2x15+3x20	2x15+20	2x20	75376 for 20MHz CC 55056 for 15MHz CC	75376/0	R.31-4 FDD for 20MHz CC, R.31-5 FDD for 15MHz CC	R.31-4 TDD	85
18	4x20+20	4x20	20	75376	75376/0	R.31-4 FDD	R.31-4 TDD	85
19	3x20+2x20	3x20	2x20	75376	75376/0	R.31-4 FDD	R.31-4 TDD	85
20	2x20+3x20	2x20	3x20	75376	75376/0	R.31-4 FDD	R.31-4 TDD	85
21	20+4x20	20	4x20	75376	75376/0	R.31-4 FDD	R.31-4 TDD	85
22	10+4x20	10	4x20	36696 for 10MHz CC	75376/0	R.31-3A FDD for 10MHz CC	R.31-4 TDD	85
23	10+20+3x20	10+20	3x20	36696 for 10MHz CC 75376 for 20MHz CC	75376/0	R.31-3A FDD for 10MHz CC, R.31-4 FDD for 20MHz CC	R.31-4 TDD	85
24	2x10+3x20	2x10	3x20	36696 for 10MHz CC	75376/0	R.31-3A FDD for 10MHz CC	R.31-4 TDD	85
25	10+2x20+2x20	10+2x20	2x20	36696 for 10MHz CC 75376 for 20MHz CC	75376/0	R.31-3A FDD for 10MHz CC, R.31-4 FDD for 20MHz CC	R.31-4 TDD	85
26	10+15+20+2x20	10+15+20	2x20	36696 for 10MHz CC 55056 for 15MHz CC 75376 for 20MHz CC	75376/0	R.31-3A FDD for 10MHz CC R.31-5 FDD for 15MHz CC R.31-4 FDD for 20MHz CC	R.31-4 TDD	85
27	20+5x20	20	5x20	75376	75376/0	R.31-4 FDD	R.31-4 TDD	85
28	2x20+4x20	2x20	4x20	75376	75376/0	R.31-4 FDD	R.31-4 TDD	85
29	20+6x20	20	6x20	75376	75376/0	R.31-4 FDD	R.31-4 TDD	85
30	2x20+5x20	2x20	5x20	75376	75376/0	R.31-4 FDD	R.31-4 TDD	85

Table 8.7.5.1-2: Test points for sustained data rate (FRC 64QAM)

CA config	Maximum supported Bandwidth/ Bandwidth combination (MHz)			Cat. 1	Cat. 2	Cat. 3	Cat. 4	Cat. 6, 7	Cat. 9,10	Cat 11, 12	DL Cat. 15
	Total	FDD CC	TDD CC					DL Cat. 6, 7	DL Cat. 9, 10	DL Cat. 11, 12	
CA with 2CCs	2x20	20	20	-	-	3	3	1	1	-	-
	10+20	10	20	-	-	3	3	2	2	-	-
	15+20	15	20	-	-	3	3	2A	2A	-	-
	10+10	10	10	-	-	3	3	3	3	-	-
CA with 3CCs	3x20	20	2x20	-	-	-	-	1	4	4	-
	15+20+20	15	2x20	-	-	-	-	2A	5	5	-
	10+20+20	10	2x20	-	-	-	-	2	6	6	-
	3x20	2x20	20	-	-	-	-	1	7	7	-
	20+20+15	20+15	20	-	-	-	-	1	8	8	-
	20+20+10	20+10	20	-	-	-	-	1	9	9	-
	20+10+10	2x10	20	-	-	-	-	2	9A	9A	-
	10+15+20	10	15+20	-	-	-	-	2	9B	9B	-
10+15+20	10+15	20	-	-	-	-	2A	9C	9C	-	
CA with 4CCs	4x20	20	3x20	-	-	-	-	-	4	10	10
	4x20	2x20	2x20	-	-	-	-	-	4 or 7	11	11
	3x20+15	20+15	2x20	-	-	-	-	-	4	12	12
	2x15+2x20	2x15	2x20	-	-	-	-	-	5	13	13
	3x20+15	2x20+15	20	-	-	-	-	-	7	14	14
	2x15+2x20	2x15+20	20	-	-	-	-	-	8	15	15
	3x20+10	2x20+10	20	-	-	-	-	-	7	15A	15A
	4x20	2x15+20	20	-	-	-	-	-	8	15B	15B
	10+3x20	10	3x20	-	-	-	-	-	6	15C	15C
	2x10+2x20	2x10	2x20	-	-	-	-	-	6	15D	15D
	2x10+20+15	2x10	20+15	-	-	-	-	-	9A	15E	15E
	10+3x20	10+20	2x20	-	-	-	-	-	4	15F	15F
	10+15+2x20	10+15	2x20	-	-	-	-	-	5	15G	15G
10+15+2x20	10+15+20	20	-	-	-	-	-	8	15H	15H	
CA with 5 CCs	4x20+15	2x20+15	2x20	-	-	-	-	-	-	11	16
	2x15+3x20	2x15+20	2x20	-	-	-	-	-	-	12	17
	4x20+20	4x20	20	-	-	-	-	-	-	-	18
	3x20+2x20	3x20	2x20	-	-	-	-	-	-	-	19
	2x20+3x20	2x20	3x20	-	-	-	-	-	-	-	20
	20+4x20	20	4x20	-	-	-	-	-	-	-	21
	10+4x20	10	4x20	-	-	-	-	-	-	-	22
	10+20+3x20	10+20	3x20	-	-	-	-	-	-	-	23
	2x10+3x20	2x10	3x20	-	-	-	-	-	-	-	24
10+2x20+2x20	10+2x20	2x20	-	-	-	-	-	-	-	25	
10+15+20+2x20	10+15+20	2x20	-	-	-	-	-	-	-	26	
CA with 6 CCs	20+5x20	20	5x20	-	-	-	-	-	-	27	27
2x20+4x20	2x20	4x20	-	-	-	-	-	-	-	28	28
CA with 7 CCs	20+6x20	20	6x20	-	-	-	-	-	-	29	29
2x20+5x20	2x20	5x20	-	-	-	-	-	-	-	30	30

Note 1: Void.  
Note 2: Void.  
Note 3: If DL category is signalled by the UE under test, then select the test point according to UE DL Category. Otherwise, select the test point according to the UE category signalled.

**Table 8.7.5.1-3: Minimum requirement (TDD FDD CA 256QAM)**

Test number	Bandwidth (MHz)			Measurement channel		Reference value TB success rate [%]
	Total	FDD CC	TDD CC	FDD CC	TDD CC	
1	2x20	20	20	R.68 FDD	R.68 TDD	85
2	10+20	10	20	R.68-2 FDD	R.68 TDD	85
3	15+20	15	20	R.68-1 FDD	R.68 TDD	85
4	3x20	20	2x20	R.68 FDD	R.68 TDD	85
5	15+20+20	15	2x20	R.68-1 FDD	R.68 TDD	85
6	10+20+20	10	2x20	R.68-2 FDD	R.68TDD	85
7	3x20	2x20	20	R.68 FDD	R.68 TDD	85
8	20+20+15	20+15	20	R.68 FDD for 20MHz CC, R.68-1 FDD for 15MHz CC	R.68 TDD	85
9	20+20+10	20+10	20	R.68 FDD for 20MHz CC, R.68-2 FDD for 10MHz CC	R.68 TDD	85
9A	20+10+10	2x10	20	R.68-2 FDD	R.68 TDD	85
9B	10+15+20	10	15+20	R.68-2 FDD	R.68-1 TDD for 15MHz CC R.68 TDD for 20MHz CC	85
9C	10+15+20	10+15	20	R.68-2 FDD for 10MHz CC, R.68-1 FDD for 15MHz CC	R.68 TDD	85
10	4x20	20	3x20	R.68-2 FDD	R.68TDD	85
11	4x20	2x20	2x20	R.68 FDD	R.68 TDD	85
12	3x20+15	20+15	2x20	R.68 FDD for 20MHz CC, R.68-1 FDD for 15MHz CC	R.68 TDD	85
13	2x15+2x20	2x15	2x20	R.68-1 FDD	R.68 TDD	85
14	3x20+15	2x20+15	20	R.68 FDD for 20MHz CC, R.68-1 FDD for 15MHz CC	R.68 TDD	85
15	2x15+2x20	2x15+20	20	R.68 FDD for 20MHz CC, R.68-1 FDD for 15MHz CC	R.68 TDD	85
15A	3x20+10	2x20+10	20	R.68 FDD for 20MHz CC, R.68-2 FDD for 10MHz CC	R.68 TDD	85
15B	4x20	3x20	20	R.68 FDD	R.68TDD	85
15C	10+3x20	10	3x20	R.68-2 FDD	R.68TDD	85
15D	2x10+2x20	2x10	2x20	R.68-2 FDD	R.68TDD	85
15E	2x10+20+15	2x10	20+15	R.68-2 FDD	R.68-1 TDD for 15MHz CC R.68 TDD for 20MHz CC	85
15F	10+3x20	10+20	2x20	R.68 FDD for 20MHz CC, R.68-2 FDD for 10MHz CC	R.68 TDD	85

15G	10+15+2x 20	10+15	2x20	R.68-2 FDD for 10MHz CC, R.68-1 FDD for 15MHz CC	R.68 TDD	85
15H	10+15+2x 20	10+15+2 0	20	R.68-2 FDD for 10MHz CC, R.68-1 FDD for 15MHz CC, R.68 FDD for 20MHz CC	R.68 TDD	85
16	4x20+15	2x20+15	2x20	R.68 FDD for 20MHz CC, R.68-1 FDD for 15MHz CC	R.68 TDD	85
17	2x15+3x2 0	2x15+20	2x20	R.68 FDD for 20MHz CC, R.68-1 FDD for 15MHz CC	R.68 TDD	85
18	4x20+20	4x20	20	R.68 FDD	R.68TDD	85
19	3x20+2x2 0	3x20	2x20	R.68 FDD	R.68 TDD	85
20	2x20+3x2 0	2x20	3x20	R.68 FDD	R.68TDD	85
21	20+4x20	20	4x20	R.68 FDD	R.68 TDD	85
22	10+4x20	10	4x20	R.68-2 FDD	R.68 TDD	85
23	10+20+3x 20	10+20	3x20	R.68 FDD for 20MHz CC, R.68-2 FDD for 10MHz CC	R.68 TDD	85
24	2x10+3x2 0	2x10	3x20	R.68-2 FDD	R.68 TDD	85
25	10+2x20+ 2x20	10+2x20	2x20	R.68 FDD for 20MHz CC, R.68-2 FDD for 10MHz CC	R.68 TDD	85
26	10+15+20 +2x20	10+15+2 0	2x20	R.68-2 FDD for 10MHz CC, R.68-1 FDD for 15MHz CC, R.68 FDD for 20MHz CC	R.68 TDD	85
27	20+5x20	20	5x20	R.68-2 FDD	R.68 TDD	85
28	2x20+4x2 0	2x20	4x20	R.68-2 FDD	R.68 TDD	85
29	20+6x20	20	6x20	R.68-2 FDD	R.68 TDD	85
30	2x20+5x2 0	2x20	5x20	R.68-2 FDD	R.68 TDD	85



Table 8.7.5.1-4: Test points for sustained data rate (FRC 256QAM)

CA config	Maximum supported Bandwidth/ Bandwidth combination (MHz)			Cat. 11, 12	DL Cat. 13	DL Cat. 15	DL Cat. 16		
	Total	FDD CC	TDD CC	DL Cat. 11, 12					
CA with 2CCs	2x20	20	20	1	1	-	-		
	10+20	10	20	2	2				
	15+20	15	20	3	3	-	-		
CA with 3CCs	3x20	20	2x20	4	1	4	-		
	15+20+20	15	2x20	5	3	5	-		
	10+20+20	10	2x20	6	2	6	-		
	3x20	2x20	20	7	1	7	-		
	20+20+15	20+15	20	8	1	8	-		
	20+20+10	20+10	20	9	1	9	-		
	20+10+10	2x10	20	9A	2	9A			
	10+15+20	10	15+20	9B	2	9B			
	10+15+20	10+15	20	9C	3	9C			
CA with 4CCs	4x20	20	3x20	4	-	10	10		
	4x20	2x20	2x20	4 or 7	-	11	11		
	3x20+15	20+15	2x20	8	-	12	12		
	2x15+2x20	2x15	2x20	5	-	13	13		
	3x20+15	2x20+15	20	7	-	14	14		
	2x15+2x20	2x15+20	20	8	-	15	15		
	3x20+10	2x20+10	20	7	-	15A	15A		
	4x20	2x15+20	20	8	-	15B	15B		
	10+3x20	10	3x20	6		15C	15C		
	2x10+2x20	2x10	2x20	6		15D	15D		
	2x10+20+15	2x10	20+15	9A		15E	15E		
	10+3x20	10+20	2x20	4		15F	15F		
	10+15+2x20	10+15	2x20	5		15G	15G		
10+15+2x20	10+15+20	20	8		15H	15H			
CA with 5CCs	4x20+15	2x20+15	2x20	-	-	14 or 12	16		
	2x15+3x20	2x15+20	2x20	-	-	15 or 12	17		
	4x20+20	4x20	20				18		
	3x20+2x20	3x20	2x20				19		
	2x20+3x20	2x20	3x20				20		
	20+4x20	20	4x20				21		
	10+4x20	10	4x20				22		
	10+20+3x20	10+20	3x20				23		
	2x10+3x20	2x10	3x20				24		
	10+2x20+2x20	10+2x20	2x20				25		
10+15+20+2x20	10+15+20	2x20				26			
CA with 6CCs	20+5x20	20	5x20				27		
	2x20+4x20	2x20	4x20				28		
CA with 7CCs	20+6x20	20	6x20				29		
	2x20+5x20	2x20	5x20				30		

Note 1: If DL category is signalled by the UE under test, then select the test point according to UE DL Category. Otherwise, select the test point according to the UE category signalled.

### 8.7.5.2 Minimum Requirement TDD PCell

For UE not supporting 256QAM, the requirements for TDD FDD CA with TDD PCell are specified in Table 8.7.5.2-1 with the additional parameters specified in Table 8.7.5-1, and the downlink physical channel setup according to Annex C.3.2. The test points are applied to UE category and bandwidth combination with maximum aggregated bandwidth as specified in Table 8.7.5.2-2. The TB success rate shall be sustained during at least 300 frames.

For UE supporting 256QAM, the requirements for TDD FDD CA with FDD PCell are specified in Table 8.7.5.2-3 with the additional parameters specified in Table 8.7.5-1, and the downlink physical channel setup according to Annex C.3.2.

The test points are applied to UE category or UE DL category, and bandwidth combination with maximum aggregated bandwidth as specified in Table 8.7.5.2-4. The TB success rate shall be sustained during at least 300 frames. For UE supporting 256QAM, the requirements in Table 8.7.5.2-1 is not applicable.

The applicability of their requirements are specified in Clause 8.1.2.3B. The test coverage for different number of component carriers is defined in 8.1.2.4.

**Table 8.7.5.2-1: test parameters for sustained downlink data rate (TDD FDD CA 64QAM)**

Test number	Bandwidth (MHz)			Number of bits of a DL-SCH transport block received within a TTI (for normal/special subframe for TDD, except for subframe #5)		Measurement channel		Reference value
	Total	FDD CC	TDD CC	FDD CC	TDD CC	FDD CC	TDD CC	TB success rate [%]
1	2x20	20	20	75376	75376/0	R.31-4 FDD	R.31-4 TDD	85
2	10+20	10	20	36696	75376/0	R.31-3A FDD	R.31-4 TDD	85
2A	15+20	15	20	55056	75376/0	R.31-5 FDD	R.31-4 TDD	85
3	10+10	10	10	36696	36696/0	R.31-3A FDD	R.31-6 TDD	85
4	3x20	20	2x20	75376	75376/0	R.31-4 FDD	R.31-4 TDD	85
5	15+20+20	15	2x20	55056	75376/0	R.31-5 FDD	R.31-4 TDD	85
6	10+20+20	10	2x20	36696	75376/0	R.31-3A FDD	R.31-4 TDD	85
7	3x20	2x20	20	75376	75376/0	R.31-4 FDD	R.31-4 TDD	85
8	20+20+15	20+15	20	75376 for 20MHz CC 55056 for 15MHz CC	75376/0	R.31-4 FDD for 20MHz CC, R.31-5 FDD for 15MHz CC	R.31-4 TDD	85
9	20+20+10	20+10	20	75376 for 20MHz CC 36696 for 10MHz CC	75376/0	R.31-4 FDD for 20MHz CC, R.31-3A FDD for 10MHz CC	R.31-4 TDD	85
9A	20+10+10	2x10	20	36696	75376/0	R.31-3A	R.31-4 TDD	85
9B	10+15+20	10	15+20	36696	75376/0 for 20MHz CC 55056/0 for 15MHz CC	R.31-3A FDD	R.31-5 TDD for 15MHz CC R.31-4 TDD for 20MHz CC	85
9C	10+15+20	10+15	20	36696 for 10MHz CC 55056 for 15MHz CC	75376/0	R.31-3A FDD for 10MHz CC R.31-5 FDD for 15MHz CC	R.31-4 TDD	85
10	4x20	20	3x20	75376	75376/0	R.31-4 FDD	R.31-4 TDD	85
11	4x20	2x20	2x20	75376	75376/0	R.31-4 FDD	R.31-4 TDD	85
12	3x20+15	20+15	2x20	75376 for 20MHz CC 55056 for 15MHz CC	75376/0	R.31-4 FDD for 20MHz CC, R.31-5 FDD for 15MHz CC	R.31-4 TDD	85
13	2x15+2x20	2x15	2x20	55056	75376/0	R.31-5 FDD	R.31-4 TDD	85
14	3x20+15	2x20+15	20	75376 for 20MHz CC 55056 for 15MHz CC	75376/0	R.31-4 FDD for 20MHz CC, R.31-5 FDD for 15MHz CC	R.31-4 TDD	85
15	2x15+2x20	2x15+20	20	75376 for 20MHz CC 55056 for 15MHz CC	75376/0	R.31-4 FDD for 20MHz CC, R.31-5 FDD for 15MHz CC	R.31-4 TDD	85
15A	3x20+10	2x20+10	20	75376 for 20MHz CC 36696 for 10MHz CC	75376/0	R.31-4 FDD for 20MHz CC, R.31-3A FDD for 10MHz CC	R.31-4 TDD	85
15B	4x20	3x20	20	75376	75376/0	R.31-4 FDD	R.31-4 TDD	85
15C	10+3x20	10	3x20	36696	75376/0	R.31-3A FDD	R.31-4 TDD	85
15D	2x10+2x20	2x10	2x20	36696	75376/0	R.31-3A FDD	R.31-4 TDD	85

15E	2x10+20+15	2x10	20+15	36696	75376/0 for 20MHz CC 55056/0 for 15MHz CC	R.31-3A FDD	R.31-5 TDD for 15MHz CC R.31-4 TDD for 20MHz CC	85
15F	10+3x20	10+20	2x20	75376 for 20MHz CC 36696 for 10MHz CC	75376/0	R.31-4 FDD for 20MHz CC, R.31-3A FDD for 10MHz CC	R.31-4 TDD	85
15G	10+15+2x20	10+15	2x20	36696 for 10MHz CC 55056 for 15MHz CC	75376/0	R.31-3A FDD for 10MHz CC R.31-5 FDD for 15MHz CC	R.31-4 TDD	85
15H	10+15+2x20	10+15+20	20	36696 for 10MHz CC 55056 for 15MHz CC 75376 for 20MHz CC	75376/0	R.31-3A FDD for 10MHz CC R.31-5 FDD for 15MHz CC R.31-4 FDD for 20MHz CC	R.31-4 TDD	85
16	4x20+15	2x20+15	2x20	75376 for 20MHz CC 55056 for 15MHz CC	75376/0	R.31-4 FDD for 20MHz CC, R.31-5 FDD for 15MHz CC	R.31-4 TDD	85
17	2x15+3x20	2x15+20	2x20	75376 for 20MHz CC 55056 for 15MHz CC	75376/0	R.31-4 FDD for 20MHz CC, R.31-5 FDD for 15MHz CC	R.31-4 TDD	85
18	4x20+20	4x20	20	75376	75376/0	R.31-4 FDD	R.31-4 TDD	85
19	3x20+2x20	3x20	2x20	75376	75376/0	R.31-4 FDD	R.31-4 TDD	85
20	2x20+3x20	2x20	3x20	75376	75376/0	R.31-4 FDD	R.31-4 TDD	85
21	20+4x20	20	4x20	75376	75376/0	R.31-4 FDD	R.31-4 TDD	85
22	10+4x20	10	4x20	36696	75376/0	R.31-3A FDD	R.31-4 TDD	85
23	10+20+3x20	10+20	3x20	75376 for 20MHz CC 36696 for 10MHz CC	75376/0	R.31-4 FDD for 20MHz CC, R.31-3A FDD for 10MHz CC	R.31-4 TDD	85
24	2x10+3x20	2x10	3x20	36696	75376/0	R.31-3A FDD	R.31-4 TDD	85
25	10+2x20+2x20	10+2x20	2x20	75376 for 20MHz CC 36696 for 10MHz CC	75376/0	R.31-4 FDD for 20MHz CC, R.31-3A FDD for 10MHz CC	R.31-4 TDD	85
26	10+15+20+2x20	10+15+20	2x20	75376 for 20MHz CC 55056 for 15MHz CC 36696 for 10MHz CC	75376/0	R.31-4 FDD for 20MHz CC, R.31-5 FDD for 15MHz CC, R.31-3A FDD for 10MHz CC	R.31-4 TDD	85
27	20+5x20	20	5x20	75376	75376/0	R.31-4 FDD	R.31-4 TDD	85
28	2x20+4x20	2x20	4x20	75376	75376/0	R.31-4 FDD	R.31-4 TDD	85
29	20+6x20	20	6x20	75376	75376/0	R.31-4 FDD	R.31-4 TDD	85
30	2x20+5x20	2x20	5x20	75376	75376/0	R.31-4 FDD	R.31-4 TDD	85

Table 8.7.5.2-2: Test points for sustained data rate (FRC 64QAM)

CA config	Maximum supported Bandwidth/ Bandwidth combination (MHz)			Cat. 1	Cat. 2	Cat. 3	Cat. 4	Cat. 6, 7	Cat. 9,10	Cat 11, 12	DL Cat. 15
	Total	FDD CC	TDD CC					DL Cat. 6, 7	DL Cat. 9, 10	DL Cat. 11, 12	
CA with 2CCs	2x20	20	20	-	-	3	3	1	1	-	-
	10+20	10	20	-	-	3	3	2	2	-	-
	15+20	15	20	-	-	3	3	2A	2A	-	-
	10+10	10	10	-	-	3	3	3	3	-	-
CA with 3CCs	3x20	20	2x20	-	-	-	-	1	4	4	-
	15+20+20	15	2x20	-	-	-	-	2A	5	5	-
	10+20+20	10	2x20	-	-	-	-	2	6	6	-
	3x20	2x20	20	-	-	-	-	1	7	7	-
	20+20+15	20+15	20	-	-	-	-	1	8	8	-
	20+20+10	20+10	20	-	-	-	-	1	9	9	-
	20+10+10	2x10	20	-	-	-	-	2	9A	9A	-
	10+15+20	10	15+20	-	-	-	-	2	9B	9B	-
10+15+20	10+15	20	-	-	-	-	2A	9C	9C	-	
CA with 4CCs	4x20	20	3x20	-	-	-	-	-	4	10	10
	4x20	2x20	2x20	-	-	-	-	-	4 or 7	11	11
	3x20+15	20+15	2x20	-	-	-	-	-	4	12	12
	2x15+2x20	2x15	2x20	-	-	-	-	-	5	13	13
	3x20+15	2x20+15	20	-	-	-	-	-	7	14	14
	2x15+2x20	2x15+20	20	-	-	-	-	-	8	15	15
	3x20+10	2x20+10	20	-	-	-	-	-	7	15A	15A
	4x20	2x15+20	20	-	-	-	-	-	8	15B	15B
	10+3x20	10	3x20	-	-	-	-	-	6	15C	15C
	2x10+2x20	2x10	2x20	-	-	-	-	-	6	15D	15D
	2x10+20+15	2x10	20+15	-	-	-	-	-	9A	15E	15E
	10+3x20	10+20	2x20	-	-	-	-	-	4	15F	15F
	10+15+2x20	10+15	2x20	-	-	-	-	-	5	15G	15G
10+15+2x20	10+15+20	20	-	-	-	-	-	8	15H	15H	
CA with 5 CCs	4x20+15	2x20+15	2x20	-	-	-	-	-	-	11	16
	2x15+3x20	2x15+20	2x20	-	-	-	-	-	-	12	17
	4x20+20	4x20	20	-	-	-	-	-	-	-	18
	3x20+2x20	3x20	2x20	-	-	-	-	-	-	-	19
	2x20+3x20	2x20	3x20	-	-	-	-	-	-	-	20
	20+4x20	20	4x20	-	-	-	-	-	-	-	21
	10+4x20	10	4x20	-	-	-	-	-	-	-	22
	10+20+3x20	10+20	3x20	-	-	-	-	-	-	-	23
	2x10+3x20	2x10	3x20	-	-	-	-	-	-	-	24
10+2x20+2x20	10+2x20	2x20	-	-	-	-	-	-	-	25	
10+15+20+2x20	10+15+20	2x20	-	-	-	-	-	-	-	26	
CA with 6 CCs	20+5x20	20	5x20	-	-	-	-	-	-	27	27
2x20+4x20	2x20	4x20	-	-	-	-	-	-	-	28	28
CA with 7 CCs	20+6x20	20	6x20	-	-	-	-	-	-	29	29
2x20+5x20	2x20	5x20	-	-	-	-	-	-	-	30	30

Note 1: Void.  
Note 2: Void.  
Note 3: If DL category is signalled by the UE under test, then select the test point according to UE DL Category. Otherwise, select the test point according to the UE category signalled.

**Table 8.7.5.2-3: Minimum requirement (TDD FDD CA 256QAM)**

Test number	Bandwidth (MHz)			Measurement channel		Reference value
	Total	FDD CC	TDD CC	FDD CC	TDD CC	TB success rate [%]
1	2x20	20	20	R.68 FDD	R.68 TDD	85
2	10+20	10	20	R.68-2 FDD	R.68 TDD	85
3	15+20	15	20	R.68-1 FDD	R.68 TDD	85
4	3x20	20	2x20	R.68 FDD	R.68 TDD	85
5	15+20+20	15	2x20	R.68-1 FDD	R.68 TDD	85
6	10+20+20	10	2x20	R.68-2 FDD	R.68TDD	85
7	3x20	2x20	20	R.68 FDD	R.68 TDD	85
8	20+20+15	20+15	20	R.68 FDD for 20MHz CC, R.68-1 FDD for 15MHz CC	R.68 TDD	85
9	20+20+10	20+10	20	R.68 FDD for 20MHz CC, R.68-2 FDD for 10MHz CC	R.68 TDD	85
9A	20+10+10	2x10	20	R.68-2 FDD	R.68 TDD	85
9B	10+15+20	10	15+20	R.68-2 FDD	R.68-1 TDD for 15MHz CC R.68 TDD for 20MHz CC	85
9C	10+15+20	10+15	20	R.68-2 FDD for 10MHz CC, R.68-1 FDD for 15MHz CC	R.68 TDD	85
10	4x20	20	3x20	R.68-2 FDD	R.68TDD	85
11	4x20	2x20	2x20	R.68 FDD	R.68 TDD	85
12	3x20+15	20+15	2x20	R.68 FDD for 20MHz CC, R.68-1 FDD for 15MHz CC	R.68 TDD	85
13	2x15+2x20	2x15	2x20	R.68-1 FDD	R.68 TDD	85
14	3x20+15	2x20+15	20	R.68 FDD for 20MHz CC, R.68-1 FDD for 15MHz CC	R.68 TDD	85
15	2x15+2x20	2x15+20	20	R.68 FDD for 20MHz CC, R.68-1 FDD for 15MHz CC	R.68 TDD	85
15A	3x20+10	2x20+10	20	R.68 FDD for 20MHz CC, R.68-2 FDD for 10MHz CC	R.68 TDD	85
15B	4x20	3x20	20	R.68 FDD	R.68TDD	85
15C	10+3x20	10	3x20	R.68-2 FDD	R.68TDD	85
15D	2x10+2x20	2x10	2x20	R.68-2 FDD	R.68TDD	85
15E	2x10+20+15	2x10	20+15	R.68-2 FDD	R.68-1 TDD for 15MHz CC R.68 TDD for 20MHz CC	85
15F	10+3x20	10+20	2x20	R.68 FDD for 20MHz CC, R.68-2 FDD for 10MHz CC	R.68 TDD	85
15G	10+15+2x20	10+15	2x20	R.68-2 FDD for 10MHz CC, R.68-1 FDD for 15MHz CC	R.68 TDD	85



15H	10+15+2x20	10+15+20	20	R.68-2 FDD for 10MHz CC, R.68-1 FDD for 15MHz CC, R.68 FDD for 20MHz CC	R.68 TDD	85
16	4x20+15	2x20+15	2x20	R.68 FDD for 20MHz CC, R.68-1 FDD for 15MHz CC	R.68 TDD	85
17	2x15+3x20	2x15+20	2x20	R.68 FDD for 20MHz CC, R.68-1 FDD for 15MHz CC	R.68 TDD	85
18	4x20+20	4x20	20	R.68 FDD	R.68 TDD	85
19	3x20+2x20	3x20	2x20	R.68 FDD	R.68 TDD	85
20	2x20+3x20	2x20	3x20	R.68 FDD	R.68 TDD	85
21	20+4x20	20	4x20	R.68 FDD	R.68 TDD	85
22	10+4x20	10	4x20	R.68-2 FDD	R.68 TDD	85
23	10+20+3x20	10+20	3x20	R.68-2 FDD for 10MHz CC, R.68 FDD for 20MHz CC	R.68 TDD	85
24	2x10+3x20	2x10	3x20	R.68-2 FDD	R.68 TDD	85
25	10+2x20+2x20	10+2x20	2x20	R.68-2 FDD for 10MHz CC, R.68 FDD for 20MHz CC	R.68 TDD	85
26	10+15+20+2x20	10+15+20	2x20	R.68-2 FDD for 10MHz CC, R.68-1 FDD for 15MHz CC, R.68 FDD for 20MHz CC	R.68 TDD	85
27	20+5x20	20	5x20	R.68-2 FDD	R.68 TDD	85
28	2x20+4x20	2x20	4x20	R.68-2 FDD	R.68 TDD	85
29	20+6x20	20	6x20	R.68-2 FDD	R.68 TDD	85
30	2x20+5x20	2x20	5x20	R.68-2 FDD	R.68 TDD	85

Table 8.7.5.2-4: Test points for sustained data rate (FRC 256QAM)

CA config	Maximum supported Bandwidth/ Bandwidth combination (MHz)			Cat. 11, 12	DL Cat. 13	DL Cat. 15	DL Cat. 16		
	Total	FDD CC	TDD CC	DL Cat. 11, 12					
CA with 2CCs	2x20	20	20	1	1	-	-		
	10+20	10	20	2	2	-	-		
	15+20	15	20	3	3	-	-		
CA with 3CCs	3x20	20	2x20	4	1	4	-		
	15+20+20	15	2x20	5	3	5	-		
	10+20+20	10	2x20	6	2	6	-		
	3x20	2x20	20	7	1	7	-		
	20+20+15	20+15	20	8	1	8	-		
	20+20+10	20+10	20	9	1	9	-		
	20+10+10	2x10	20	9A	2	9A			
	10+15+20	10	15+20	9B	2	9B			
	10+15+20	10+15	20	9C	3	9C			
CA with 4CCs	4x20	20	3x20	4	-	10	10		
	4x20	2x20	2x20	4 or 7	-	11	11		
	3x20+15	20+15	2x20	8	-	12	12		
	2x15+2x20	2x15	2x20	5	-	13	13		
	3x20+15	2x20+15	20	7	-	14	14		
	2x15+2x20	2x15+20	20	8	-	15	15		
	3x20+10	2x20+10	20	7	-	15A	15A		
	4x20	2x15+20	20	8	-	15B	15B		
	10+3x20	10	3x20	6		15C	15C		
	2x10+2x20	2x10	2x20	6		15D	15D		
	2x10+20+15	2x10	20+15	9A		15E	15E		
	10+3x20	10+20	2x20	4		15F	15F		
	10+15+2x20	10+15	2x20	5		15G	15G		
	10+15+2x20	10+15+20	20	8		15H	15H		
CA with 5CCs	4x20+15	2x20+15	2x20	-	-	14 or 12	16		
	2x15+3x20	2x15+20	2x20	-	-	15 or 12	17		
	4x20+20	4x20	20				18		
	3x20+2x20	3x20	2x20				19		
	2x20+3x20	2x20	3x20				20		
	20+4x20	20	4x20				21		
	10+4x20	10	4x20				22		
	10+20+3x20	10+20	3x20				23		
	2x10+3x20	2x10	3x20				24		
	10+2x20+2x20	10+2x20	2x20				25		
CA with 6CCs	20+5x20	20	5x20				27		
	2x20+4x20	2x20	4x20				28		
CA with 7CCs	20+6x20	20	6x20				29		
	2x20+5x20	2x20	5x20				30		

Note 1: If DL category is signalled by the UE under test, then select the test point according to UE DL Category. Otherwise, select the test point according to the UE category signalled.

## 8.7.6 FDD (DC)

The parameters specified in Table 8.7.6-1 are valid for all FDD DC tests unless otherwise stated.

Table 8.7.6-1: Common Test Parameters (FDD)

Parameter	Unit	Value	
Cyclic prefix		Normal	
Cell ID		0	
Inter-TTI Distance		1	
Number of HARQ processes per component carrier	Processes	8	
Maximum number of HARQ transmission		4	
Redundancy version coding sequence		{0,0,1,2} for 64QAM and 256QAM	
Number of OFDM symbols for PDCCH per component carrier	OFDM symbols	1	
Cross carrier scheduling		Not configured	
Propagation condition		Static propagation condition No external noise sources are applied	
Transmission mode		TM3	
Codebook subset restriction		10	
Antenna configuration		2x2	
$\hat{E}_s$ at antenna port (dBm/15kHz)		-85	
Symbols for unused PRBs		OP.1 FDD	
ACK/NACK feedback mode		Separate ACK/NACK feedbacks with PUCCH format 3 on the MCG and SCG	
Time offset between MCG CC and SCG CC	$\mu$ s	0 for UE under test supporting synchronous dual connectivity; 500 for UE under test supporting both asynchronous and synchronous dual connectivity (Note 1)	
Downlink power allocation	$\rho_A$	dB	-3
	$\rho_B$	dB	-3
	$\sigma$	dB	0
Note 1: Asynchronous and synchronous dual connectivity are defined in TS36.300 [11].			
Note 2: If the UE supports both SCG bearer and Split bearer, the Split bearer is configured.			

For UE not supporting 256QAM, the requirements are specified in Table 8.7.6-2, with the addition of the parameters in Table 8.7.6-1 and the downlink physical channel setup according to Annex C.3.2. The test points are applied to UE category and bandwidth combination with maximum aggregated bandwidth as specified in Table 8.7.6-3. The TB success rate across CGs shall be sustained during at least 300 frames.

For UE supporting 256QAM, the requirements are specified in Table 8.7.6-4, with the addition of the parameters in Table 8.7.6-1 and the downlink physical channel setup according to Annex C.3.2. The test points are applied to UE category and bandwidth combination with maximum aggregated bandwidth as specified in Table 8.7.6-5. The TB success rate across CGs shall be sustained during at least 300 frames. For UE supporting 256QAM, the requirements in Table 8.7.6-2 are not applicable.

The applicability of their requirements are specified in Clause 8.1.2.3A.

**Table 8.7.6-2: Minimum requirement (DC 64QAM)**

Test number	Bandwidth combination (MHz)	Number of bits of a DL-SCH transport block received within a TTI	Measurement channel	Reference value TB success rate(%)		
				DRB type of Split bearer (Note 2)	DRB type of SCG bearer (Note 3)	
					MCG	SCG
1	2x10	25456	R.31-2 FDD	95	95	95
2	2x10	36696 (Note 4)	R.31-3A FDD	85	85	85
3	10+20	36696 (Note 4) for 10MHz CC 75376 (Note 5) for 20MHz CC	R.31-3A FDD for 10MHz CC R.31-4 FDD for 20MHz CC	85	85	85
4	2x15	55056 (Note 6)	R.31-4B FDD	85	85	85
5	15+20	55056 for 15MHz CC 75376 (Note 5) for 20MHz CC	R.31-5 FDD for 15MHz CC R.31-4 FDD for 20MHz CC	85	85	85
6	2x20	75376 (Note 5)	R.31-4 FDD	85	85	85
6A	10+15	36696 (Note 4) for 10MHz CC 55056 (Note 6) for 15MHz CC	R.31-2 FDD for 10MHz CC R.31-5 FDD for 15MHz CC	85	85	85
7	15+5	55056 for 15MHz CC 18336 for 5MHz CC	R.31-5 FDD for 15MHz CC R.31-6 FDD for 5MHz CC	85	85	85
8	15+20+20	55056 for 15MHz CC 75376 (Note 5) for 20MHz CC	R.31-5 FDD for 15MHz CC R.31-4 FDD for 20MHz CC	85	85	85
9	15+15+20	55056 for 15MHz CC 75376 (Note 5) for 20MHz CC	R.31-5 FDD for 15MHz CC R.31-4 FDD for 20MHz CC	85	85	85
10	10+10+20	36696 (Note 4) for 10MHz CC 75376 (Note 5) for 20MHz CC	R.31-2 FDD for 10MHz CC R.31-4 FDD for 20MHz CC	85	85	85
11	10+15+15	36696 (Note 4) for 10MHz CC 55056 (Note 6) for 15MHz CC	R.31-2 FDD for 10MHz CC R.31-5 FDD for 15MHz CC	85	85	85
12	10+15+20	36696 (Note 4) for 10MHz CC 55056 (Note 6) for 15MHz CC 75376 (Note 5) for 20MHz CC	R.31-2 FDD for 10MHz CC R.31-5 FDD for 15MHz CC R.31-4 FDD for 20MHz CC	85	85	85
13	10+20+20	36696 (Note 4) for 10MHz CC 75376 (Note 5) for 20MHz CC	R.31-2 FDD for 10MHz CC R.31-4 FDD for 20MHz CC	85	85	85
14	3x20	75376 (Note 5)	R.31-4 FDD	85	85	85

Note 1:	For 2 layer transmissions, 2 transport blocks are received within a TTI.
Note 2:	For the configuration of DRB type of Split bearer, the TB success rate across CGs is defined as TB success rate = $100\% \cdot N_{DL\_correct\_rx} / (N_{DL\_newtx} + N_{DL\_retr})$ , where $N_{DL\_newtx}$ is the number of newly transmitted DL transport blocks, $N_{DL\_retr}$ is the number of retransmitted DL transport blocks, and $N_{DL\_correct\_rx}$ is the number of correctly received DL transport blocks. All the above numbers of transmitted, retransmitted or correctly received DL transport blocks are calculated as the sum of the numbers of DL transport blocks across all the CGs used for DC transmission or reception.
Note 3:	For the configuration of DRB type of SCG bearer, the TB success rate across CGs is defined as TB success rate = $100\% \cdot N_{DL\_correct\_rx} / (N_{DL\_newtx} + N_{DL\_retr})$ , where $N_{DL\_newtx}$ is the number of newly transmitted DL transport blocks, $N_{DL\_retr}$ is the number of retransmitted DL transport blocks, and $N_{DL\_correct\_rx}$ is the number of correctly received DL transport blocks. All the above numbers of transmitted, retransmitted or correctly received DL transport blocks are calculated as the sum of the numbers of DL transport blocks per CG used for DC transmission or reception, separately.
Note 4:	35160 bits for sub-frame 5.
Note 5:	71112 bits for sub-frame 5.
Note 6:	52752 bits for sub-frame 5.

Table 8.7.6-3: Test points for sustained data rate (FRC DC 64QAM)

DC config	Maximum supported Bandwidth combination (MHz)	Cat. 3	Cat. 4	Cat. 6, 7	Cat. 9, 10	Cat. 11, 12	
						DL Cat. 11,12	
DC with 2CCs	2x10	1	2	2	2	-	
	10+20	1	2	3	3	-	
	2x15	1	2	4	4	-	
	15+20	1	2	5	5	-	
	2x20	1	2	6	6	-	
	10+15	1	2	6A	6A	-	
	15+5	7	7	7	7	-	
DC with 3 CCs	15+20+20	-	-	8	8	8	
	15+15+20	-	-	9	9	9	
	10+10+20	-	-	10	10	10	
	10+15+15	-	-	11	11	11	
	10+15+20	-	-	12	12	12	
	10+20+20	-	-	13	13	13	
	20+20+20	-	-	14	14	14	

**Table 8.7.6-4: Minimum requirement (DC 256QAM)**

Test number	Bandwidth combination (MHz)	Measurement channel	Reference value TB success rate (%)		
			DRB type of Split bearer (Note 2)	DRB type of SCG bearer (Note 3)	
				MCG	SCG
1	2x10	R.68-2 FDD	85	85	85
2	10+20	R.68-2 FDD for 10MHz CC R.68 FDD for 20MHz CC	85	85	85
3	2x15	R.68-1 FDD	85	85	85
4	15+20	R.68-1 FDD for 15MHz CC R.68 FDD for 20MHz CC	85	85	85
5	2x20	R.68 FDD	85	85	85
6	15+5	R.68-1 FDD for 15MHz CC R.68-3 FDD for 5MHz CC	85	85	85
6A	10+15	R.68-2 FDD for 10MHz CC R.68-1 FDD for 15MHz CC	85	85	85
7	15+20+20	R.68-1 FDD for 15MHz CC R.68 FDD for 20MHz CC	85	85	85
8	15+15+20	R.68-1 FDD for 15MHz CC R.68 FDD for 20MHz CC	85	85	85
9	10+10+20	R.68-2 FDD for 10MHz CC R.68 FDD for 20MHz CC	85	85	85
10	10+15+15	R.68-2 FDD for 10MHz CC R.68-1 FDD for 15MHz CC	85	85	85
11	10+15+20	R.68-2 FDD for 10MHz CC R.68-1 FDD for 15MHz CC R.68 FDD for 20MHz CC	85	85	85
12	10+20+20	R.68-2 FDD for 10MHz CC R.68 FDD for 20MHz CC	85	85	85
13	20+20+20	R.68 FDD	85	85	85
Note 1:	For 2 layer transmissions, 2 transport blocks are received within a TTI.				
Note 2:	For the configuration of DRB type of Split bearer, the TB success rate across CGs is defined as TB success rate = $100\% \cdot N_{DL\_correct\_rx} / (N_{DL\_newtx} + N_{DL\_retr})$ , where $N_{DL\_newtx}$ is the number of newly transmitted DL transport blocks, $N_{DL\_retr}$ is the number of retransmitted DL transport blocks, and $N_{DL\_correct\_rx}$ is the number of correctly received DL transport blocks. All the above numbers of transmitted, retransmitted or correctly received DL transport blocks are calculated as the sum of the numbers of DL transport blocks across all the CGs used for DC transmission or reception.				
Note 3:	For the configuration of DRB type of SCG bearer, the TB success rate across CGs is defined as TB success rate = $100\% \cdot N_{DL\_correct\_rx} / (N_{DL\_newtx} + N_{DL\_retr})$ , where $N_{DL\_newtx}$ is the number of newly transmitted DL transport blocks, $N_{DL\_retr}$ is the number of retransmitted DL transport blocks, and $N_{DL\_correct\_rx}$ is the number of correctly received DL transport blocks. All the above numbers of transmitted, retransmitted or correctly received DL transport blocks are calculated as the sum of the numbers of DL transport blocks per CG used for DC transmission or reception, separately.				



Table 8.7.6-5: Test points for sustained data rate (FRC DC 256QAM)

DC config	Maximum supported Bandwidth combination (MHz)	Cat. 11, 12	DL Cat. 13	DL Cat.15			
		DL Cat. 11,12					
DC with 2CCs	2x10	1	1				
	10+20	2	2				
	2x15	3	3				
	15+20	4	4				
	2x20	5	5				
	10+15	6A	6A	-			
	15+5	6	6				
DC with 3CCs	15+20+20	7	5				
	15+15+20	8	4	8			
	10+10+20	9	2	9			
	10+15+15	10	3	10			
	10+15+20	11	4	11			
	10+20+20	12	5	12			
	20+20+20	13	5	13			

### 8.7.7 TDD (DC)

The parameters specified in Table 8.7.7-1 are valid for all TDD DC tests unless otherwise stated.

Table 8.7.7-1: Common Test Parameters (TDD)

Parameter	Unit	Value	
Uplink downlink configuration		2 (Note 2)	
Special subframe configuration		4	
Cyclic prefix		Normal	
Cell ID		0	
Inter-TTI Distance		1	
Number of HARQ processes per component carrier	Processes	7	
Maximum number of HARQ transmission		4	
Redundancy version coding sequence		{0,0,1,2} for 64QAM and 256QAM	
Number of OFDM symbols for PDCCCH per component carrier	OFDM symbols	1	
Cross carrier scheduling		Not configured	
Propagation condition		Static propagation condition No external noise sources are applied	
Transmission mode		TM3	
Codebook subset restriction		10	
Antenna configuration		2x2	
$\hat{E}_s$ at antenna port (dBm/15kHz)		-85	
Symbols for unused PRBs		OP.1 TDD	
ACK/NACK feedback mode		Separate ACK/NACK feedbacks with PUCCH format 3 on the MCG and SCG	
Time offset between MCG CC and SCG CC	$\mu$ s	0 for UE under test supporting synchronous dual connectivity; 500 for UE under test supporting both asynchronous and synchronous dual connectivity (Note 1)	
Downlink power allocation	$\rho_A$	dB	-3
	$\rho_B$	dB	-3
	$\sigma$	dB	0
Note 1: Asynchronous and synchronous dual connectivity are defined in TS36.300 [11].			
Note 2: If the UE supports both SCG bearer and Split bearer, the Split bearer is configured.			

For UE not supporting 256QAM, the requirements are specified in Table 8.7.7-2, with the addition of the parameters in Table 8.7.7-1 and the downlink physical channel setup according to Annex C.3.2. The test points are applied to UE category and bandwidth combination with maximum aggregated bandwidth as specified in Table 8.7.7-3. The TB success rate shall be sustained during at least 300 frames.

For UE supporting 256QAM, the requirements are specified in Table 8.7.7-4, with the addition of the parameters in Table 8.7.7-1 and the downlink physical channel setup according to Annex C.3.2. The test points are applied to UE category and bandwidth combination with maximum aggregated bandwidth as specified in Table 8.7.7-5. The TB success rate shall be sustained during at least 300 frames. For UE supporting 256QAM, the requirements in Table 8.7.7-2 are not applicable.

The applicability of the requirements are specified in Clause 8.1.2.3A.

Table 8.7.7-2: Minimum requirement (DC 64QAM)

Test number	Bandwidth combination (MHz)	Number of bits of a DL-SCH transport block received within a TTI	Measurement channel	Reference value TB success rate across CGs(%)		
				DRB type of Split bearer (Note 2)	DRB type of SCG bearer (Note 3)	
					MCG	SCG
1	2x20	75376/0 (Note 4)	R.31-4A TDD	85	85	85
2	3x20	75376/0 (Note 4)	R.31-4A TDD	85	85	85
3	4x20	75376/0 (Note 4)	R.31-4A TDD	85	85	85
4	15+3x20	55056/0 for 15MHz CC 75376/0 for 20MHz CC (Note 4)	R.31-5 TDD for 15MHz CC R.31-4 TDD for 20MHz CC	85	85	85
Note 1:	For 2 layer transmissions, 2 transport blocks are received within a TTI.					
Note 2:	For the configuration of DRB type of Split bearer, the TB success rate across CGs is defined as TB success rate = $100\% \cdot N_{DL\_correct\_rx} / (N_{DL\_newtx} + N_{DL\_retx})$ , where $N_{DL\_newtx}$ is the number of newly transmitted DL transport blocks, $N_{DL\_retx}$ is the number of retransmitted DL transport blocks, and $N_{DL\_correct\_rx}$ is the number of correctly received DL transport blocks. All the above numbers of transmitted, retransmitted or correctly received DL transport blocks are calculated as the sum of the numbers of DL transport blocks across all the CGs used for DC transmission or reception.					
Note 3:	For the configuration of DRB type of SCG bearer, the TB success rate across CGs is defined as TB success rate = $100\% \cdot N_{DL\_correct\_rx} / (N_{DL\_newtx} + N_{DL\_retx})$ , where $N_{DL\_newtx}$ is the number of newly transmitted DL transport blocks, $N_{DL\_retx}$ is the number of retransmitted DL transport blocks, and $N_{DL\_correct\_rx}$ is the number of correctly received DL transport blocks. All the above numbers of transmitted, retransmitted or correctly received DL transport blocks are calculated as the sum of the numbers of DL transport blocks per CG used for DC transmission or reception, separately.					
Note 4:	71112 bits for sub-frame 5.					

Table 8.7.7-3: Test points for sustained data rate (FRC DC 64QAM)

DC config	Maximum supported Bandwidth combination (MHz)	Cat. 3	Cat. 4	Cat. 6, 7	Cat. 9, 10	Cat. 11, 12	DL Cat.15
						DL Cat. 11, 12	
DC with 2CCs	2x20	-	-	1	1	-	-
DC with 3CCs	3x20	-	-	1	2	2	-
DC with 4CCs	4x20	-	-	-	2	3	3
	15+3x20	-	-	-	2	4	4

Table 8.7.7-4: Minimum requirement (DC 256QAM)

Test number	Bandwidth combination (MHz)	Measurement channel	Reference value TB success rate (%)		
			DRB type of Split bearer (Note 2)	DRB type of SCG bearer (Note 3)	
				MCG	SCG
1	2x20	R.68-3 TDD	85	85	85
Note 1:	For 2 layer transmissions, 2 transport blocks are received within a TTI.				
Note 2:	For the configuration of DRB type of Split bearer, the TB success rate across CGs is defined as TB success rate = $100\% \cdot N_{DL\_correct\_rx} / (N_{DL\_newtx} + N_{DL\_retx})$ , where $N_{DL\_newtx}$ is the number of newly transmitted DL transport blocks, $N_{DL\_retx}$ is the number of retransmitted DL transport blocks, and $N_{DL\_correct\_rx}$ is the number of correctly received DL transport blocks. All the above numbers of transmitted, retransmitted or correctly received DL transport blocks are calculated as the sum of the numbers of DL transport blocks across all the CGs used for DC transmission or reception.				
Note 3:	For the configuration of DRB type of SCG bearer, the TB success rate across CGs is defined as TB success rate = $100\% \cdot N_{DL\_correct\_rx} / (N_{DL\_newtx} + N_{DL\_retx})$ , where $N_{DL\_newtx}$ is the number of newly transmitted DL transport blocks, $N_{DL\_retx}$ is the number of retransmitted DL transport blocks, and $N_{DL\_correct\_rx}$ is the number of correctly received DL transport blocks. All the above numbers of transmitted, retransmitted or correctly received DL transport blocks are calculated as the sum of the numbers of DL transport blocks per CG used for DC transmission or reception, separately.				

Table 8.7.7-5: Test points for sustained data rate (FRC DC 256QAM)

DC config	Maximum supported Bandwidth combination (MHz)	Cat. 11, 12	DL Cat. 13	DL Cat. 15	DL Cat. 16		
		DL Cat. 11, 12					
DC with 2CCs	2x20	1	1	-	-		
DC with 3CCs	3x20	2	1	2	-		
DC with 4CCs	4x20	2	-	3	3		
	15+3x20	2	-	4	4		

### 8.7.8 TDD FDD (DC)

The parameters specified in Table 8.7.8-1 are valid for all TDD FDD DC tests unless otherwise stated.

Table 8.7.8-1: Common Test Parameters (TDD FDD DC)

Parameter	Unit	Value	
Uplink downlink configuration for TDD CC			2 (Note 2)
Special subframe configuration for TDD CC			4
Cyclic prefix			Normal
Cell ID			0
Inter-TTI Distance			1
Number of HARQ processes per component carrier	Processes		8 for FDD CC; 7 for TDD CC
Maximum number of HARQ transmission			4
Redundancy version coding sequence			{0,0,1,2} for 64QAM and 256QAM
Number of OFDM symbols for PDCCH per component carrier	OFDM symbols		1
Cross carrier scheduling			Not configured
Propagation condition			Static propagation condition No external noise sources are applied
Transmission mode			TM3
Codebook subset restriction			10
Antenna configuration			2x2
$\hat{E}_s$ at antenna port (dBm/15kHz)			-85
Symbols for unused PRBs			OP.1 TDD for TDD CC; OP.1 FDD for FDD CC
ACK/NACK feedback mode			Separate ACK/NACK feedbacks with PUCCH format 3 on the MCG and SCG
Time offset between MCG CC and SCG CC	$\mu$ s		0 for UE under test supporting synchronous dual connectivity; 500 for UE under test supporting both asynchronous and synchronous dual connectivity (Note 1)
Downlink power allocation	$\rho_A$	dB	-3
	$\rho_B$	dB	-3
	$\sigma$	dB	0
Note 1: Asynchronous and synchronous dual connectivity are defined in TS36.300 [11].			
Note 2: If the UE supports both SCG bearer and Split bearer, the Split bearer is configured.			

For UE not supporting 256QAM, the requirements are specified in Table 8.7.8-2, with the addition of the parameters in Table 8.7.8-1 and the downlink physical channel setup according to Annex C.3.2. The test points are applied to UE category and bandwidth combination with maximum aggregated bandwidth as specified in Table 8.7.8-3. The TB success rate shall be sustained during at least 300 frames.

For UE supporting 256QAM, the requirements are specified in Table 8.7.8-4, with the addition of the parameters in Table 8.7.7-1 and the downlink physical channel setup according to Annex C.3.2. The test points are applied to UE category and bandwidth combination with maximum aggregated bandwidth as specified in Table 8.7.8-5. The TB success rate shall be sustained during at least 300 frames. For UE supporting 256QAM, the requirements in Table 8.7.8-2 are not applicable.

The applicability of their requirements are specified in Clause 8.1.2.3A.

Table 8.7.8-2: Minimum requirement (TDD FDD DC 64QAM)

Test number	Bandwidth (MHz)			Number of bits of a DL-SCH transport block received within a TTI (for normal/special subframe for TDD, except for subframe #5)		Measurement channel		Reference value TB success rate across CGs(%)		
								DRB type of Split bearer (Note 2)	DRB type of SCG bearer (Note 3)	
	Total	FDD CC	TDD CC	FDD CC	TDD CC	FDD CC	TDD CC		MCG	SCG
1	2x20	20	20	75376 (Note 4)	75376/0 (Note 4)	R.31-4 FDD	R.31-4A TDD	85	85	85
Note 1:	For 2 layer transmissions, 2 transport blocks are received within a TTI.									
Note 2:	For the configuration of DRB type of Split bearer, the TB success rate across CGs is defined as TB success rate = $100\% \cdot N_{DL\_correct\_rx} / (N_{DL\_newtx} + N_{DL\_retx})$ , where $N_{DL\_newtx}$ is the number of newly transmitted DL transport blocks, $N_{DL\_retx}$ is the number of retransmitted DL transport blocks, and $N_{DL\_correct\_rx}$ is the number of correctly received DL transport blocks. All the above numbers of transmitted, retransmitted or correctly received DL transport blocks are calculated as the sum of the numbers of DL transport blocks across all the CGs used for DC transmission or reception.									
Note 3:	For the configuration of DRB type of SCG bearer, the TB success rate across CGs is defined as TB success rate = $100\% \cdot N_{DL\_correct\_rx} / (N_{DL\_newtx} + N_{DL\_retx})$ , where $N_{DL\_newtx}$ is the number of newly transmitted DL transport blocks, $N_{DL\_retx}$ is the number of retransmitted DL transport blocks, and $N_{DL\_correct\_rx}$ is the number of correctly received DL transport blocks. All the above numbers of transmitted, retransmitted or correctly received DL transport blocks are calculated as the sum of the numbers of DL transport blocks per CG used for DC transmission or reception, separately.									
Note 4:	71112 bits for sub-frame 5.									

Table 8.7.8-3: Test points for sustained data rate (FRC TDD FDD DC 64QAM)

CA config	Maximum supported Bandwidth/ Bandwidth combination (MHz)			Cat. 6, 7	Cat. 9,10	
	Total	FDD CC	TDD CC			
DC with 2CCs	2x20	20	20	1	1	

Table 8.7.8-4: Minimum requirement (TDD FDD DC 256QAM)

Test number	Bandwidth (MHz)			Measurement channel		Reference value TB success rate across CGs(%)		
						DRB type of Split bearer (Note 2)	DRB type of SCG bearer (Note 3)	
	Total	FDD CC	TDD CC	FDD CC	TDD CC		MCG	SCG

1	2x20	20	20	R.68 FDD	R.68-3 TDD	85	85	85
<p>Note 1: For 2 layer transmissions, 2 transport blocks are received within a TTI.</p> <p>Note 2: For the configuration of DRB type of Split bearer, the TB success rate across CGs is defined as TB success rate = <math>100\% \cdot N_{DL\_correct\_rx} / (N_{DL\_newtx} + N_{DL\_retr})</math>, where <math>N_{DL\_newtx}</math> is the number of newly transmitted DL transport blocks, <math>N_{DL\_retr}</math> is the number of retransmitted DL transport blocks, and <math>N_{DL\_correct\_rx}</math> is the number of correctly received DL transport blocks. All the above numbers of transmitted, retransmitted or correctly received DL transport blocks are calculated as the sum of the numbers of DL transport blocks across all the CGs used for DC transmission or reception.</p> <p>Note 3: For the configuration of DRB type of SCG bearer, the TB success rate across CGs is defined as TB success rate = <math>100\% \cdot N_{DL\_correct\_rx} / (N_{DL\_newtx} + N_{DL\_retr})</math>, where <math>N_{DL\_newtx}</math> is the number of newly transmitted DL transport blocks, <math>N_{DL\_retr}</math> is the number of retransmitted DL transport blocks, and <math>N_{DL\_correct\_rx}</math> is the number of correctly received DL transport blocks. All the above numbers of transmitted, retransmitted or correctly received DL transport blocks are calculated as the sum of the numbers of DL transport blocks per CG used for DC transmission or reception, separately.</p>								

Table 8.7.8-5: Test points for sustained data rate (FRC TDD FDD DC 256QAM)

CA config	Maximum supported Bandwidth/ Bandwidth combination (MHz)			Cat. 11, 12	DL Cat. 13				
	Total	FDD CC	TDD CC	DL Cat. 11, 12					
DC with 2CCs	2x20	20	20	1	1				
<p>Note 1: If DL category is signalled by the UE under test, then select the test point according to UE DL Category. Otherwise, select the test point according to the UE category signalled.</p>									

### 8.7.9 FDD (4 Rx)

The parameters specified in Table 8.7.9-1 are valid for all FDD tests for 4Rx capable UEs unless otherwise stated.

**Table 8.7.9-1: Common Test Parameters (FDD)**

Parameter	Unit	Value
Transmission mode		3
Cyclic prefix		Normal
Cell ID		0
Inter-TTI Distance		1
Number of HARQ processes per component carrier	Processes	8
Maximum number of HARQ transmission		4
Redundancy version coding sequence		{0,0,1,2} for 64QAM and 256QAM
Number of OFDM symbols for PDCCH per component carrier	OFDM symbols	1
Cross carrier scheduling		Not configured
Propagation condition		Static propagation condition No external noise sources are applied
$\hat{E}_s$ at antenna port	dBm/15kHz	-85
Antenna configuration	2 layer CC	2x2 or 2x4
	4 layer CC	4x4
Codebook subset restriction	2 layer CC	10
	4 layer CC	1000
Downlin power allocation	2 layer CC	$\rho_A = -3\text{dB}$ , $\rho_B = -3\text{dB}$ , $\sigma = 0\text{dB}$
	4 layer CC	$\rho_A = -6\text{dB}$ , $\rho_B = -6\text{dB}$ , $\sigma = 3\text{dB}$
Symbols for unused PRBs		OP.1 FDD

For UE not supporting 256QAM, the TB success rate shall be higher than 85% when PDSCH are scheduled with FRC in Table 8.7.9-2 with the downlink physical channel setup according to Annex C.3.2.

For UE supporting 256QAM, the TB success rate shall be higher than 85% when PDSCH are scheduled with FRC in Table 8.7.9-3 with the downlink physical channel setup according to Annex C.3.2. For UE supporting 256QAM, the requirement with 64QAM is not applicable.

The TB success rate is defined as  $100\% \cdot N_{\text{DL\_correct\_rx}} / (N_{\text{DL\_newtx}} + N_{\text{DL\_retx}})$ , where  $N_{\text{DL\_newtx}}$  is the number of newly transmitted DL transport blocks,  $N_{\text{DL\_retx}}$  is the number of retransmitted DL transport blocks, and  $N_{\text{DL\_correct\_rx}}$  is the number of correctly received DL transport blocks. The TB success rate shall be sustained during at least 300 frames.

**Table 8.7.9-2: Per-CC FRC for SDR test (FDD 64QAM)**

MIMO layer	Bandwidth	Reference channel
2 layer	5	R.31-6 FDD
	10	R.31-3A FDD
	15	R.31-5 FDD
	20	R.31-4 FDD
4 layer	5	R.31-10 FDD
	10	R.31-7 FDD
	15	R.31-8 FDD
	20	R.31-9 FDD



**Table 8.7.9-3: Per-CC FRC for SDR test (FDD 256QAM)**

MIMO layer	Bandwidth	Reference channel
2 layer	5	R.68-3 FDD
	10	R.68-2 FDD
	15	R.68-1 FDD
	20	R.68 FDD
4 layer	5	R.68-7 FDD
	10	R.68-4 FDD
	15	R.68-5 FDD
	20	R.68-6 FDD

CA configuration, bandwidth combination and MIMO layer on each CC is determined by following procedure.

- Select one CA bandwidth combination among all supported CA configurations with bandwidth combination and MIMO layer on each CC that leads to largest equivalent aggregated bandwidth among all CA bandwidth combinations supported by UE. Equivalent aggregated bandwidth is defined as

$$B_{agg} = \prod_{i=0}^{N-1} R_i B_i$$

where  $N$  is number of CCs,  $R_i \in \{2,4\}$  and  $B_i \in \{5,10,15,20\}$  is MIMO layer and bandwidth of CC  $i$ .

- When there are multiple sets of {CA configuration, bandwidth combination, MIMO layer} with same largest aggregated bandwidth, select one among sets with largest number of 4 layer CCs.
- The procedure applies also for single carrier using operating band instead of CA configuration, and bandwidth instead of bandwidth combination.

**Table 8.7.9-4: Void**

**Table 8.7.9-5: Void**

## 8.7.10 TDD (4 Rx)

The parameters specified in Table 8.7.10-1 are valid for all TDD tests for 4Rx capable UEs unless otherwise stated.

Table 8.7.10-1: Common Test Parameters (TDD)

Parameter	Unit	Value
Transmission mode		3
Special subframe configuration (Note 1)		4
Cyclic prefix		Normal
Cell ID		0
Inter-TTI Distance		1
Number of HARQ processes per component carrier	Processes	8
Maximum number of HARQ transmission		4
Redundancy version coding sequence		{0,0,1,2} for 64QAM and 256QAM
Number of OFDM symbols for PDCCH per component carrier	OFDM symbols	1
Cross carrier scheduling		Not configured
Propagation condition		Static propagation condition No external noise sources are applied
$\hat{E}_s$ at antenna port	dBm/15kHz	-85
Symbols for unused PRBs		OP.1 TDD
Antenna configuration	2 layer CC	2x2 or 2x4
	4 layer CC	4x4
Codebook subset restriction	2 layer CC	10
	4 layer CC	1000
Downlink power allocation	2 layer CC	$\rho_A = -3\text{dB}$ , $\rho_B = -3\text{dB}$ , $\sigma = 0\text{dB}$
	4 layer CC	$\rho_A = -6\text{dB}$ , $\rho_B = -6\text{dB}$ , $\sigma = 3\text{dB}$
Symbols for unused PRBs		OP.1 TDD

For UE not supporting 256QAM, the TB success rate shall be higher than 85% when PDSCH are scheduled with FRC in Table 8.7.10-2 with the downlink physical channel setup according to Annex C.3.2.

For UE supporting 256QAM, the TB success rate shall be higher than 85% when PDSCH are scheduled with FRC in Table 8.7.10-3 with the downlink physical channel setup according to Annex C.3.2. For UE supporting 256QAM, the requirement with 64QAM is not applicable.

The TB success rate is defined as  $100\% \cdot N_{\text{DL\_correct\_rx}} / (N_{\text{DL\_newtx}} + N_{\text{DL\_retx}})$ , where  $N_{\text{DL\_newtx}}$  is the number of newly transmitted DL transport blocks,  $N_{\text{DL\_retx}}$  is the number of retransmitted DL transport blocks, and  $N_{\text{DL\_correct\_rx}}$  is the number of correctly received DL transport blocks. The TB success rate shall be sustained during at least 300 frames.

Table 8.7.10-2: Per-CC FRC for SDR test(TDD 64QAM)

MIMO layer	Bandwidth	Reference channel
2 layer	10	R.31-6 TDD
	15	R.31-5 TDD
	20	R.31-4 TDD
4 layer	10	R.31-7 TDD
	15	R.31-8 TDD
	20	R.31-9 TDD

**Table 8.7.10-3: Per-CC FRC for SDR test (TDD 256QAM)**

MIMO layer	Bandwidth	Reference channel
2 layer	10	R.68-2 TDD
	15	R.68-1 TDD
	20	R.68 TDD
4 layer	10	R.68-5 TDD
	15	R.68-6 TDD
	20	R.68-7 TDD

CA configuration, bandwidth combination and MIMO layer on each CC is determined by following procedure.

- Select one CA bandwidth combination among all supported CA configurations with bandwidth combination and MIMO layer on each CC that leads to largest equivalent aggregated bandwidth among all CA bandwidth combinations supported by UE. Equivalent aggregated bandwidth is defined as

$$B_{agg} = \prod_{i=0}^{N-1} R_i B_i$$

where  $N$  is number of CCs,  $R_i \in \{2,4\}$  and  $B_i \in \{5,10,15,20\}$  is MIMO layer and bandwidth of CC  $i$ .

- When there are multiple sets of {CA configuration, bandwidth combination, MIMO layer} with same largest aggregated bandwidth, select one among sets with largest number of 4 layer CCs.
- The procedure applies also for single carrier using operating band instead of CA configuration, and bandwidth instead of bandwidth combination.

**Table 8.7.10-4: Void**

**Table 8.7.10-5: Void**

### 8.7.11 TDD FDD CA (4 Rx)

The parameters specified in Table 8.7.11-1 are valid for all TDD FDD CA tests for 4Rx capable UEs unless otherwise stated.

Table 8.7.11-1: Common Test Parameters (TDD FDD CA)

Parameter	Unit	FDD CC	TDD CC
Transmission mode		3	3
Uplink downlink configuration (Note 1)		N/A	1
Special subframe configuration (Note 2)		N/A	4
Cyclic prefix		Normal	Normal
Cell ID		0	0
Inter-TTI Distance		1	1
Number of HARQ processes per component carrier	Processes	8	8
Maximum number of HARQ transmission		4	4
Redundancy version coding sequence		{0,0,1,2} for 64QAM and 256QAM	{0,0,1,2} for 64QAM and 256QAM
Number of OFDM symbols for PDCCH per component carrier	OFDM symbols	1	1
Cross carrier scheduling		Not configured	Not configured
Propagation condition		Static propagation condition No external noise sources are applied	Static propagation condition No external noise sources are applied
$\hat{E}_s$ at antenna port	dBm/15kHz	-85	-85
Antenna configuration	2 layer CC	2x2 or 2x4	2x2 or 2x4
	4 layer CC	4x4	4x4
Codebook subset restriction	2 layer CC	10	10
	4 layer CC	1000	1000
Downlink power allocation	2 layer CC	$\rho_A = -3\text{dB}, \rho_B = -3\text{dB}, \sigma = 0\text{dB}$	$\rho_A = -3\text{dB}, \rho_B = -3\text{dB}, \sigma = 0\text{dB}$
	4 layer CC	$\rho_A = -6\text{dB}, \rho_B = -6\text{dB}, \sigma = 3\text{dB}$	$\rho_A = -6\text{dB}, \rho_B = -6\text{dB}, \sigma = 3\text{dB}$
Symbols for unused PRBs		OP.1 FDD	OP.1 TDD
Note 1: as specified in Table 4.2-2 in TS 36.211 [4].			
Note 2: as specified in Table 4.2-1 in TS 36.211 [4].			

For UE not supporting 256QAM, the TB success rate shall be higher than 85% when PDSCH are scheduled with FRC in Table 8.7.11-2 with the downlink physical channel setup according to Annex C.3.2.

For UE supporting 256QAM, the TB success rate shall be higher than 85% when PDSCH are scheduled with FRC in Table 8.7.11-3 with the downlink physical channel setup according to Annex C.3.2. For UE supporting 256QAM, the requirement with 64QAM is not applicable.

The TB success rate is defined as  $100\% \cdot N_{\text{DL\_correct\_rx}} / (N_{\text{DL\_newtx}} + N_{\text{DL\_retx}})$ , where  $N_{\text{DL\_newtx}}$  is the number of newly transmitted DL transport blocks,  $N_{\text{DL\_retx}}$  is the number of retransmitted DL transport blocks, and  $N_{\text{DL\_correct\_rx}}$  is the number of correctly received DL transport blocks. The TB success rate shall be sustained during at least 300 frames.

**Table 8.7.11-2: Per-CC FRC for SDR test (TDD-FDD 64QAM)**

MIMO layer	Bandwidth	FDD Reference channel	TDD Reference channel
2 layer	5	R.31-6 FDD	N/A
	10	R.31-3A FDD	R.31-6 TDD
	15	R.31-5 FDD	R.31-5 TDD
	20	R.31-4 FDD	R.31-4 TDD
4 layer	5	R.31-10 FDD	N/A
	10	R.31-7 FDD	R.31-7 TDD
	15	R.31-8 FDD	R.31-8 TDD
	20	R.31-9 FDD	R.31-9 TDD

**Table 8.7.11-3: Per-CC FRC for SDR test (TDD-FDD 256QAM)**

MIMO layer	Bandwidth	FDD Reference channel	TDD Reference channel
2 layer	5	R.68-3 FDD	N/A
	10	R.68-2 FDD	R.68-2 TDD
	15	R.68-1 FDD	R.68-1 TDD
	20	R.68 FDD	R.68 TDD
4 layer	5	R.68-7 FDD	N/A
	10	R.68-4 FDD	R.68-5 TDD
	15	R.68-5 FDD	R.68-6 TDD
	20	R.68-6 FDD	R.68-7 TDD

CA configuration, bandwidth combination and MIMO layer on each CC is determined by following procedure.

- Select one CA bandwidth combination among all supported CA configurations with bandwidth combination and MIMO layer on each CC that leads to largest equivalent aggregated bandwidth among all CA bandwidth combinations supported by UE. Equivalent aggregated bandwidth is defined as

$$B_{agg} = \prod_{i=0}^{N-1} R_i B_i$$

where  $N$  is number of CCs,  $R_i \in \{2,4\}$  and  $B_i \in \{5,10,15,20\}$  is MIMO layer and bandwidth of CC  $i$ .

- When there are multiple sets of {CA configuration, bandwidth combination, MIMO layer} with same largest aggregated bandwidth, select one among sets with largest number of 4 layer CCs.

### 8.7.11.1 Void

**Table 8.7.11.1-1: Void**

**Table 8.7.11.1-2: Void**

**Table 8.7.11.1-3: Void**

**Table 8.7.11.1-4: Void**

## 8.7.12 LAA

### 8.7.12.1 FDD CA in licensed bands

The parameters specified in Table 8.7.12.1-1 are valid for all LAA CA SDR tests unless otherwise stated.

Table 8.7.12.1-1: Common Test Parameters

Parameter	Unit	FDD CC	LAA CC
Transmission mode		3	
Cyclic prefix		Normal	
Cell ID		0	0
Inter-TTI Distance		1	
Number of HARQ processes per component carrier	Processes	8	
Maximum number of HARQ transmission		4	
Redundancy version coding sequence		{0,0,1,2} for 64QAM and 256QAM	
Number of OFDM symbols for PDCCH per component carrier	OFDM symbols	1	
Cross carrier scheduling		Not configured	
Propagation condition		Static propagation condition (B.1) No external noise sources are applied	
$\hat{E}_s$ at antenna port	dBm/15kHz	-85	
Antenna configuration	2 layer CC	2x2 or 2x4	
	4 layer CC	4x4	
Codebook subset restriction	2 layer CC	10	
	4 layer CC	1000	
Downlink power allocation	2 layer CC	$\rho_A = -3\text{dB}$ , $\rho_B = -3\text{dB}$ , $\sigma = 0\text{dB}$	
	4 layer CC	$\rho_A = -6\text{dB}$ , $\rho_B = -6\text{dB}$ , $\sigma = 3\text{dB}$	
Symbols for unused PRBs		OP.1 FDD	OP.1 FS3

For UE not supporting 256QAM, the TB success rate shall be higher than 85% when PDSCH are scheduled with FRC in Table 8.7.12.1-2 with the downlink physical channel setup according to Annex C.3.2.

For UE supporting 256QAM, the TB success rate shall be higher than 85% when PDSCH are scheduled with FRC in Table 8.7.12.1-3 with the downlink physical channel setup according to Annex C.3.2. For UE supporting 256QAM, the requirement with 64QAM is not applicable.

For LAA SCell, per-CC separate FRCs are defined for different UE capability for endingDwPTS and secondSlotStartingPosition.

The TB success rate is defined as  $100\% * N_{\text{DL\_correct\_rx}} / (N_{\text{DL\_newtx}} + N_{\text{DL\_retx}})$ , where  $N_{\text{DL\_newtx}}$  is the number of newly transmitted DL transport blocks,  $N_{\text{DL\_retx}}$  is the number of retransmitted DL transport blocks, and  $N_{\text{DL\_correct\_rx}}$  is the number of correctly received DL transport blocks. The TB success rate shall be sustained during at least 300 frames.

Table 8.7.12.1-2: Per-CC FRC for SDR test (64QAM)

MIMO layer	Bandwidth (MHz)	FDD	LAA supporting end partial SF	LAA supporting initial partial SF but not supporting end partial SF	LAA not supporting both initial and end partial SF
2 layer	5	R.31-6 FDD	N/A	N/A	N/A
	10	R.31-3A FDD	N/A	N/A	N/A
	15	R.31-5 FDD	N/A	NA	NA
	20	R.31-4 FDD	R.6 FS3	R.7 FS3	R.5 FS3
4 layer	5	R.31-10 FDD	N/A	N/A	N/A
	10	R.31-7 FDD	N/A	N/A	N/A
	15	R.31-8 FDD	N/A	N/A	N/A
	20	R.31-9 FDD	R.9 FS3	R.10 FS3	R.8 FS3

Table 8.7.12.1-3: Per-CC FRC for SDR test (256QAM)

MIMO layer	Bandwidth (MHz)	FDD	LAA supporting end partial SF	LAA supporting initial partial SF but not supporting end partial SF	LAA not supporting both initial and end partial SF
2 layer	5	R.68-3 FDD	N/A	N/A	N/A
	10	R.68-2 FDD	N/A	N/A	N/A
	15	R.68-1 FDD	N/A	NA	NA
	20	R.68 FDD	R.12 FS3	R.13 FS3	R.11 FS3
4 layer	5	R.68-7 FDD	N/A	N/A	N/A
	10	R.68-4 FDD	N/A	N/A	N/A
	15	R.68-5 FDD	N/A	N/A	N/A
	20	R.68-6 FDD	R.15 FS3	R.16 FS3	R.14 FS3

CA configuration, bandwidth combination and MIMO layer on each CC is determined by following procedure.

- Select one CA bandwidth combination among all supported CA configurations with bandwidth combination and MIMO layer on each CC following the equation that leads to largest equivalent aggregated bandwidth among all CA bandwidth combinations supported by UE. Equivalent aggregated bandwidth is defined as

$$B_{agg} = \prod_{i=0}^{N-1} R_i B_i$$

where  $N$  is number of CCs,  $R_i \in \{2,4\}$  and  $B_i \in \{5,10,15,20\}$  is MIMO layer and bandwidth of CC  $i$ .

- When there are multiple sets of {CA configuration, bandwidth combination, MIMO layer} with same largest aggregated bandwidth, select one among sets with largest number of 4 layer CCs.

### 8.7.12.2 TDD CA in licensed bands

The parameters specified in Table 8.7.12.2-1 are valid for all LAA CA SDR tests unless otherwise stated.

Table 8.7.12.2-1: Common Test Parameters

Parameter	Unit	TDD CC	LAA CC
Transmission mode		3	
Uplink downlink configuration (Note 1)		1	N/A
Special subframe configuration (Note 2)		4	N/A
Cyclic prefix		Normal	
Cell ID		0	0
Inter-TTI Distance		1	
Number of HARQ processes per component carrier	Processes	8	
Maximum number of HARQ transmission		4	
Redundancy version coding sequence		{0,0,1,2} for 64QAM and 256QAM	
Number of OFDM symbols for PDCCH per component carrier	OFDM symbols	1	
Cross carrier scheduling		Not configured	
Propagation condition		Static propagation condition (B.1) No external noise sources are applied	
$\hat{E}_s$ at antenna port	dBm/15kHz	-85	
Antenna configuration	2 layer CC	2x2 or 2x4	
	4 layer CC	4x4	
Codebook subset restriction	2 layer CC	10	
	4 layer CC	1000	
Downlink power allocation	2 layer CC	$\rho_A = -3\text{dB}$ , $\rho_B = -3\text{dB}$ , $\sigma = 0\text{dB}$	
	4 layer CC	$\rho_A = -6\text{dB}$ , $\rho_B = -6\text{dB}$ , $\sigma = 3\text{dB}$	
Symbols for unused PRBs		OP.1 TDD	OP.1 FS3
Note 1:	as specified in Table 4.2-2 in TS 36.211 [4].		
Note 2:	as specified in Table 4.2-1 in TS 36.211 [4].		

For UE not supporting 256QAM, the TB success rate shall be higher than 85% when PDSCH are scheduled with FRC in Table 8.7.12.2-2 with the downlink physical channel setup according to Annex C.3.2.

For UE supporting 256QAM, the TB success rate shall be higher than 85% when PDSCH are scheduled with FRC in Table 8.7.12.2-3 with the downlink physical channel setup according to Annex C.3.2. For UE supporting 256QAM, the requirement with 64QAM is not applicable.

For LAA SCell, per-CC separate FRCs are defined for different UE capability for endingDwPTS and secondSlotStartingPosition.

The TB success rate is defined as  $100\% \cdot N_{\text{DL\_correct\_rx}} / (N_{\text{DL\_newtx}} + N_{\text{DL\_retx}})$ , where  $N_{\text{DL\_newtx}}$  is the number of newly transmitted DL transport blocks,  $N_{\text{DL\_retx}}$  is the number of retransmitted DL transport blocks, and  $N_{\text{DL\_correct\_rx}}$  is the number of correctly received DL transport blocks. The TB success rate shall be sustained during at least 300 frames.



Table 8.7.12.2-2: Per-CC FRC for SDR test (64QAM)

MIMO layer	Bandwidth (MHz)	FDD	LAA supporting end partial SF	LAA supporting initial partial SF but not supporting end partial SF	LAA not supporting both initial and end partial SF
2 layer	5	N/A	N/A	N/A	N/A
	10	R.31-6 TDD	N/A	N/A	N/A
	15	R.31-5 TDD	N/A	NA	NA
	20	R.31-4 TDD	R.6 FS3	R.7 FS3	R.5 FS3
4 layer	5	N/A	N/A	N/A	N/A
	10	R.31-7 TDD	N/A	N/A	N/A
	15	R.31-8 TDD	N/A	N/A	N/A
	20	R.31-9 TDD	R.9 FS3	R.10 FS3	R.8 FS3

Table 8.7.12.2-3: Per-CC FRC for SDR test (256QAM)

MIMO layer	Bandwidth (MHz)	FDD	LAA supporting end partial SF	LAA supporting initial partial SF but not supporting end partial SF	LAA not supporting both initial and end partial SF
2 layer	5	N/A	N/A	N/A	N/A
	10	R.68-2 TDD	N/A	N/A	N/A
	15	R.68-1 TDD	N/A	NA	NA
	20	R.68 TDD	R.12 FS3	R.13 FS3	R.11 FS3
4 layer	5	N/A	N/A	N/A	N/A
	10	R.68-4 TDD	N/A	N/A	N/A
	15	R.68-5 TDD	N/A	N/A	N/A
	20	R.68-6 TDD	R.15 FS3	R.16 FS3	R.14 FS3

CA configuration, bandwidth combination and MIMO layer on each CC is determined by following procedure.

- Select one CA bandwidth combination among all supported CA configurations with bandwidth combination and MIMO layer on each CC following the equation that leads to largest equivalent aggregated bandwidth among all CA bandwidth combinations supported by UE. Equivalent aggregated bandwidth is defined as

$$B_{agg} = \prod_{i=0}^{N-1} R_i B_i$$

where  $N$  is number of CCs,  $R_i \in \{2,4\}$  and  $B_i \in \{5,10,15,20\}$  is MIMO layer and bandwidth of CC  $i$ .

- When there are multiple sets of {CA configuration, bandwidth combination, MIMO layer} with same largest aggregated bandwidth, select one among sets with largest number of 4 layer CCs.

### 8.7.12.3 TDD-FDD CA in licensed bands

The parameters specified in Table 8.7.12.3-1 are valid for all LAA CA SDR tests unless otherwise stated.

Table 8.7.12.3-1: Common Test Parameters

Parameter	Unit	FDD CC	TDD CC	LAA CC
Transmission mode		3		
Uplink downlink configuration (Note 1)		N/A	1	N/A
Special subframe configuration (Note 2)		N/A	4	N/A
Cyclic prefix		Normal		
Cell ID		0	0	0
Inter-TTI Distance		1		
Number of HARQ processes per component carrier	Processes	8		
Maximum number of HARQ transmission		4		
Redundancy version coding sequence		{0,0,1,2} for 64QAM and 256QAM		
Number of OFDM symbols for PDCCH per component carrier	OFDM symbols	1		
Cross carrier scheduling		Not configured		
Propagation condition		Static propagation condition (B.1) No external noise sources are applied		
$\hat{E}_s$ at antenna port	dBm/15kHz	-85		
Antenna configuration	2 layer CC	2x2 or 2x4		
	4 layer CC	4x4		
Codebook subset restriction	2 layer CC	10		
	4 layer CC	1000		
Downlink power allocation	2 layer CC	$\rho_A = -3\text{dB}$ , $\rho_B = -3\text{dB}$ , $\sigma = 0\text{dB}$		
	4 layer CC	$\rho_A = -6\text{dB}$ , $\rho_B = -6\text{dB}$ , $\sigma = 3\text{dB}$		
Symbols for unused PRBs		OP.1 FDD	OP.1 TDD	OP.1 FS3
Note 1:	as specified in Table 4.2-2 in TS 36.211 [4].			
Note 2:	as specified in Table 4.2-1 in TS 36.211 [4].			

For UE not supporting 256QAM, the TB success rate shall be higher than 85% when PDSCH are scheduled with FRC in Table 8.7.12.3-2 with the downlink physical channel setup according to Annex C.3.2.

For UE supporting 256QAM, the TB success rate shall be higher than 85% when PDSCH are scheduled with FRC in Table 8.7.12.3-3 with the downlink physical channel setup according to Annex C.3.2. For UE supporting 256QAM, the requirement with 64QAM is not applicable.

For LAA SCell, per-CC separate FRCs are defined for different UE capability for endingDwPTS and secondSlotStartingPosition.

The TB success rate is defined as  $100\% * N_{\text{DL\_correct\_rx}} / (N_{\text{DL\_newtx}} + N_{\text{DL\_retr}})$ , where  $N_{\text{DL\_newtx}}$  is the number of newly transmitted DL transport blocks,  $N_{\text{DL\_retr}}$  is the number of retransmitted DL transport blocks, and  $N_{\text{DL\_correct\_rx}}$  is the number of correctly received DL transport blocks. The TB success rate shall be sustained during at least 300 frames.

Table 8.7.12.3-2: Per-CC FRC for SDR test (64QAM)

MIMO layer	Bandwidth (MHz)	FDD	TDD	LAA supporting end partial SF	LAA supporting initial partial SF but not supporting end partial SF	LAA not supporting both initial and end partial SF
2 layer	5	R.31-6 FDD	N/A	N/A	N/A	N/A
	10	R.31-3A FDD	R.31-6 TDD	N/A	N/A	N/A
	15	R.31-5 FDD	R.31-5 TDD	N/A	NA	NA
	20	R.31-4 FDD	R.31-4 TDD	R.6 FS3	R.7 FS3	R.5 FS3
4 layer	5	R.31-10 FDD	N/A	N/A	N/A	N/A
	10	R.31-7 FDD	R.31-7 TDD	N/A	N/A	N/A
	15	R.31-8 FDD	R.31-8 TDD	N/A	N/A	N/A
	20	R.31-9 FDD	R.31-9 TDD	R.9 FS3	R.10 FS3	R.8 FS3

Table 8.7.12.3-3: Per-CC FRC for SDR test (256QAM)

MIMO layer	Bandwidth (MHz)	FDD	TDD	LAA supporting end partial SF	LAA supporting initial partial SF but not supporting end partial SF	LAA not supporting both initial and end partial SF
2 layer	5	R.68-3 FDD	N/A	N/A	N/A	N/A
	10	R.68-2 FDD	R.68-2 TDD	N/A	N/A	N/A
	15	R.68-1 FDD	R.68-1 TDD	N/A	NA	NA
	20	R.68 FDD	R.68 TDD	R.12 FS3	R.13 FS3	R.11 FS3
4 layer	5	R.68-7 FDD	N/A	N/A	N/A	N/A
	10	R.68-4 FDD	R.68-4 TDD	N/A	N/A	N/A
	15	R.68-5 FDD	R.68-5 TDD	N/A	N/A	N/A
	20	R.68-6 FDD	R.68-6 TDD	R.15 FS3	R.16 FS3	R.14 FS3

CA configuration, bandwidth combination and MIMO layer on each CC is determined by following procedure.

- Select one CA bandwidth combination among all supported CA configurations with bandwidth combination and MIMO layer on each CC following the equation that leads to largest equivalent aggregated bandwidth among all CA bandwidth combinations supported by UE. Equivalent aggregated bandwidth is defined as

$$B_{agg} = \prod_{i=0}^{N-1} R_i B_i$$

where  $N$  is number of CCs,  $R_i \in \{2,4\}$  and  $B_i \in \{5,10,15,20\}$  is MIMO layer and bandwidth of CC  $i$ .

- When there are multiple sets of {CA configuration, bandwidth combination, MIMO layer} with same largest aggregated bandwidth, select one among sets with largest number of 4 layer CCs.

## 8.7.13 FDD DC (4 Rx)

The parameters specified in Table 8.7.13-1 are valid for all FDD tests for 4Rx capable UEs unless otherwise stated.

**Table 8.7.13-1: Common Test Parameters (FDD)**

Parameter	Unit	Value
Transmission mode		3
Cyclic prefix		Normal
Cell ID		0
Inter-TTI Distance		1
Number of HARQ processes per component carrier	Processes	8
Maximum number of HARQ transmission		4
Redundancy version coding sequence		{0,0,1,2} for 64QAM and 256QAM
Number of OFDM symbols for PDCCH per component carrier	OFDM symbols	1
Cross carrier scheduling		Not configured
Propagation condition		Static propagation condition No external noise sources are applied
$\hat{E}_s$ at antenna port	dBm/15kHz	-85
Antenna configuration	2 layer CC	2x2 or 2x4
	4 layer CC	4x4
Codebook subset restriction	2 layer CC	10
	4 layer CC	1000
Downlink power allocation	2 layer CC	$\rho_A = -3\text{dB}$ , $\rho_B = -3\text{dB}$ , $\sigma = 0\text{dB}$
	4 layer CC	$\rho_A = -6\text{dB}$ , $\rho_B = -6\text{dB}$ , $\sigma = 3\text{dB}$
Symbols for unused PRBs		OP.1 FDD
ACK/NACK feedback mode		Separate ACK/NACK feedbacks with PUCCH format 3 on the MCG and SCG
Time offset between MCG CC and SCG CC	$\mu\text{s}$	0 for UE under test supporting synchronous dual connectivity; 500 for UE under test supporting both asynchronous and synchronous dual connectivity (Note 1)
Note 1: Asynchronous and synchronous dual connectivity are defined in TS36.300 [11]. Note 2: If the UE supports both SCG bearer and Split bearer, the Split bearer is configured.		

For UE not supporting 256QAM, the TB success rate shall be higher than 85% when PDSCH are scheduled with FRC in Table 8.7.13-2 with the downlink physical channel setup according to Annex C.3.2.

For UE supporting 256QAM, the TB success rate shall be higher than 85% when PDSCH are scheduled with FRC in Table 8.7.13-3 with the downlink physical channel setup according to Annex C.3.2. For UE supporting 256QAM, the requirement with 64QAM is not applicable.

The TB success rate is defined as  $100\% \cdot N_{\text{DL\_correct\_rx}} / (N_{\text{DL\_newtx}} + N_{\text{DL\_retx}})$ , where  $N_{\text{DL\_newtx}}$  is the number of newly transmitted DL transport blocks,  $N_{\text{DL\_retx}}$  is the number of retransmitted DL transport blocks, and  $N_{\text{DL\_correct\_rx}}$  is the number of correctly received DL transport blocks. The TB success rate across CGs shall be sustained during at least 300 frames.

Table 8.7.13-2: Per-CC FRC for SDR test (FDD 64QAM)

MIMO layer	Bandwidth	Reference channel
2 layer	5	R.31-6 FDD
	10	R.31-3A FDD
	15	R.31-5 FDD
	20	R.31-4 FDD
4 layer	5	R.31-10 FDD
	10	R.31-7 FDD
	15	R.31-8 FDD
	20	R.31-9 FDD

Table 8.7.13-3: Per-CC FRC for SDR test (FDD 256QAM)

MIMO layer	Bandwidth	Reference channel
2 layer	5	R.68-3 FDD
	10	R.68-2 FDD
	15	R.68-1 FDD
	20	R.68 FDD
4 layer	5	R.68-7 FDD
	10	R.68-4 FDD
	15	R.68-5 FDD
	20	R.68-6 FDD

DC configuration, bandwidth combination and MIMO layer on each CC is determined by following procedure.

- Select one DC bandwidth combination among all supported DC configurations with bandwidth combination and MIMO layer on each CC that leads to largest equivalent aggregated bandwidth among all DC bandwidth combinations supported by UE. Equivalent aggregated bandwidth is defined as

$$B_{agg} = \prod_{i=0}^{N-1} R_i B_i$$

where  $N$  is number of CCs,  $R_i \in \{2,4\}$  and  $B_i \in \{5,10,15,20\}$  is MIMO layer and bandwidth of CC  $i$ .

- When there are multiple sets of {DC configuration, bandwidth combination, MIMO layer} with same largest aggregated bandwidth, select one among sets with largest number of 4 layer CCs.

### 8.7.14 TDD DC (4 Rx)

The parameters specified in Table 8.7.14-1 are valid for all TDD tests for 4Rx capable UEs unless otherwise stated.

Table 8.7.14-1: Common Test Parameters (TDD)

Parameter	Unit	Value
Transmission mode		3
Special subframe configuration		4
Cyclic prefix		Normal
Cell ID		0
Inter-TTI Distance		1
Number of HARQ processes per component carrier	Processes	8
Maximum number of HARQ transmission		4
Redundancy version coding sequence		{0,0,1,2} for 64QAM and 256QAM
Number of OFDM symbols for PDCCH per component carrier	OFDM symbols	1
Cross carrier scheduling		Not configured
Propagation condition		Static propagation condition No external noise sources are applied
$\hat{E}_s$ at antenna port	dBm/15kHz	-85
Antenna configuration	2 layer CC	2x2 or 2x4
	4 layer CC	4x4
Codebook subset restriction	2 layer CC	10
	4 layer CC	1000
Downlink power allocation	2 layer CC	$\rho_A = -3\text{dB}$ , $\rho_B = -3\text{dB}$ , $\sigma = 0\text{dB}$
	4 layer CC	$\rho_A = -6\text{dB}$ , $\rho_B = -6\text{dB}$ , $\sigma = 3\text{dB}$
Symbols for unused PRBs		OP.1 TDD
ACK/NACK feedback mode		Separate ACK/NACK feedbacks with PUCCH format 3 on the MCG and SCG
Time offset between MCG CC and SCG CC	$\mu\text{s}$	0 for UE under test supporting synchronous dual connectivity; 500 for UE under test supporting both asynchronous and synchronous dual connectivity (Note 1)
Note 1: Asynchronous and synchronous dual connectivity are defined in TS36.300 [11].		
Note 2: If the UE supports both SCG bearer and Split bearer, the Split bearer is configured.		

For UE not supporting 256QAM, the TB success rate shall be higher than 85% when PDSCH are scheduled with FRC in Table 8.7.14-2 with the downlink physical channel setup according to Annex C.3.2.

For UE supporting 256QAM, the TB success rate shall be higher than 85% when PDSCH are scheduled with FRC in Table 8.7.14-3 with the downlink physical channel setup according to Annex C.3.2. For UE supporting 256QAM, the requirement with 64QAM is not applicable.

The TB success rate is defined as  $100\% \cdot N_{\text{DL\_correct\_rx}} / (N_{\text{DL\_newtx}} + N_{\text{DL\_retx}})$ , where  $N_{\text{DL\_newtx}}$  is the number of newly transmitted DL transport blocks,  $N_{\text{DL\_retx}}$  is the number of retransmitted DL transport blocks, and  $N_{\text{DL\_correct\_rx}}$  is the number of correctly received DL transport blocks. The TB success rate across CGs shall be sustained during at least 300 frames.

Table 8.7.14-2: Per-CC FRC for SDR test (TDD 64QAM)

MIMO layer	Bandwidth	Reference channel
2 layer	10	R.31-6 TDD
	15	R.31-5 TDD
	20	R.31-4 TDD
4 layer	10	R.31-7 TDD
	15	R.31-8 TDD
	20	R.31-9 TDD

Table 8.7.14-3: Per-CC FRC for SDR test (TDD 256QAM)

MIMO layer	Bandwidth	Reference channel
2 layer	10	R.68-2 TDD
	15	R.68-1 TDD
	20	R.68 TDD
4 layer	10	R.68-5 TDD
	15	R.68-6 TDD
	20	R.68-7 TDD

DC configuration, bandwidth combination and MIMO layer on each CC is determined by following procedure.

- Select one DC bandwidth combination among all supported DC configurations with bandwidth combination and MIMO layer on each CC that leads to largest equivalent aggregated bandwidth among all DC bandwidth combinations supported by UE. Equivalent aggregated bandwidth is defined as

$$B_{agg} = \prod_{i=0}^{N-1} R_i B_i$$

where  $N$  is number of CCs,  $R_i \in \{2,4\}$  and  $B_i \in \{5,10,15,20\}$  is MIMO layer and bandwidth of CC  $i$ .

- When there are multiple sets of {DC configuration, bandwidth combination, MIMO layer} with same largest aggregated bandwidth, select one among sets with largest number of 4 layer CCs.

### 8.7.15 TDD FDD DC (4 Rx)

The parameters specified in Table 8.7.15-1 are valid for all TDD FDD tests for 4Rx capable UEs unless otherwise stated.

Table 8.7.15-1: Common Test Parameters (TDD FDD)

Parameter	Unit	FDD CC	TDD CC
Transmission mode		3	3
Uplink downlink configuration (Note 1)		N/A	1
Special subframe configuration (Note 2)		N/A	4
Cyclic prefix		Normal	Normal
Cell ID		0	0
Inter-TTI Distance		1	1
Number of HARQ processes per component carrier	Processes	8	8
Maximum number of HARQ transmission		4	4
Redundancy version coding sequence		{0,0,1,2} for 64QAM and 256QAM	{0,0,1,2} for 64QAM and 256QAM
Number of OFDM symbols for PDCCH per component carrier	OFDM symbols	1	1
Cross carrier scheduling		Not configured	Not configured
Propagation condition		Static propagation condition No external noise sources are applied	Static propagation condition No external noise sources are applied
$\hat{E}_s$ at antenna port	dBm/15kHz	-85	-85
Antenna configuration	2 layer CC	2x2 or 2x4	2x2 or 2x4
	4 layer CC	4x4	4x4
Codebook subset restriction	2 layer CC	10	10
	4 layer CC	1000	1000
Downlink power allocation	2 layer CC	$\rho_A = -3\text{dB}$ , $\rho_B = -3\text{dB}$ , $\sigma = 0\text{dB}$	$\rho_A = -3\text{dB}$ , $\rho_B = -3\text{dB}$ , $\sigma = 0\text{dB}$
	4 layer CC	$\rho_A = -6\text{dB}$ , $\rho_B = -6\text{dB}$ , $\sigma = 3\text{dB}$	$\rho_A = -6\text{dB}$ , $\rho_B = -6\text{dB}$ , $\sigma = 3\text{dB}$
Symbols for unused PRBs		OP.1 FDD	OP.1 TDD
ACK/NACK feedback mode		Separate ACK/NACK feedbacks with PUCCH format 3 on the MCG and SCG	
Time offset between MCG CC and SCG CC	$\mu\text{s}$	0 for UE under test supporting synchronous dual connectivity; 500 for UE under test supporting both asynchronous and synchronous dual connectivity (Note 1)	
Note 1:	as specified in Table 4.2-2 in TS 36.211 [4].		
Note 2:	as specified in Table 4.2-1 in TS 36.211 [4].		
Note 3:	Asynchronous and synchronous dual connectivity are defined in TS36.300 [11].		
Note 4:	If the UE supports both SCG bearer and Split bearer, the Split bearer is configured.		

For UE not supporting 256QAM, the TB success rate shall be higher than 85% when PDSCH are scheduled with FRC in Table 8.7.15-2 with the downlink physical channel setup according to Annex C.3.2.

For UE supporting 256QAM, the TB success rate shall be higher than 85% when PDSCH are scheduled with FRC in Table 8.7.15-3 with the downlink physical channel setup according to Annex C.3.2. For UE supporting 256QAM, the requirement with 64QAM is not applicable.

The TB success rate is defined as  $100\% \cdot N_{\text{DL\_correct\_rx}} / (N_{\text{DL\_newtx}} + N_{\text{DL\_retx}})$ , where  $N_{\text{DL\_newtx}}$  is the number of newly transmitted DL transport blocks,  $N_{\text{DL\_retx}}$  is the number of retransmitted DL transport blocks, and  $N_{\text{DL\_correct\_rx}}$  is the



number of correctly received DL transport blocks. The TB success rate across CGs shall be sustained during at least 300 frames.

**Table 8.7.15-2: Per-CC FRC for SDR test (TDD-FDD 64QAM)**

MIMO layer	Bandwidth	FDD Reference channel	TDD Reference channel
2 layer	5	R.31-6 FDD	N/A
	10	R.31-3A FDD	R.31-6 TDD
	15	R.31-5 FDD	R.31-5 TDD
	20	R.31-4 FDD	R.31-4 TDD
4 layer	5	R.31-10 FDD	N/A
	10	R.31-7 FDD	R.31-7 TDD
	15	R.31-8 FDD	R.31-8 TDD
	20	R.31-9 FDD	R.31-9 TDD

**Table 8.7.15-3: Per-CC FRC for SDR test (TDD-FDD 256QAM)**

MIMO layer	Bandwidth	FDD Reference channel	TDD Reference channel
2 layer	5	R.68-3 FDD	N/A
	10	R.68-2 FDD	R.68-2 TDD
	15	R.68-1 FDD	R.68-1 TDD
	20	R.68 FDD	R.68 TDD
4 layer	5	R.68-7 FDD	N/A
	10	R.68-4 FDD	R.68-5 TDD
	15	R.68-5 FDD	R.68-6 TDD
	20	R.68-6 FDD	R.68-7 TDD

DC configuration, bandwidth combination and MIMO layer on each CC is determined by following procedure.

- Select one DC bandwidth combination among all supported DC configurations with bandwidth combination and MIMO layer on each CC that leads to largest equivalent aggregated bandwidth among all DC bandwidth combinations supported by UE. Equivalent aggregated bandwidth is defined as

$$B_{agg} = \sum_{i=0}^{N-1} R_i B_i$$

where  $N$  is number of CCs,  $R_i \in \{2,4\}$  and  $B_i \in \{5,10,15,20\}$  is MIMO layer and bandwidth of CC  $i$ .

- When there are multiple sets of {DC configuration, bandwidth combination, MIMO layer} with same largest aggregated bandwidth, select one among sets with largest number of 4 layer CCs.

## 8.7.16 FDD (1024QAM and up to 4Rx supported)

The common parameters are specified in Table 8.7.16-1 for UE which is capable of supporting 1024QAM.

Table 8.7.16-1: Common Test Parameters (FDD)

Parameter	Unit	Value
-----------	------	-------

Transmission mode		3
Cyclic prefix		Normal
Cell ID		0
Inter-TTI Distance		1
Number of HARQ processes per component carrier	Processes	8
Maximum number of HARQ transmission		4
Redundancy version coding sequence		{0,0,1,2} for 64QAM, 256QAM and 1024QAM
Number of OFDM symbols for PDCCH per component carrier	OFDM symbols	1
Cross carrier scheduling		Not configured
Propagation condition		Static propagation condition No external noise sources are applied
$\hat{E}_s$ at antenna port	dBm/15kHz	-85
Antenna configuration	2 layer CC	2x2 or 2x4
	4 layer CC	4x4
Codebook subset restriction	2 layer CC	10
	4 layer CC	1000
Downlin power allocation	2 layer CC	$\rho_A = -3\text{dB}$ , $\rho_B = -3\text{dB}$ , $\sigma = 0\text{dB}$
	4 layer CC	$\rho_A = -6\text{dB}$ , $\rho_B = -6\text{dB}$ , $\sigma = 3\text{dB}$
Symbols for unused PRBs		OP.1 FDD

The UE capability for 1024QAM is signalled per band or per band combination, hence the SDR tests with the mixed modulation orders and the mixed receiver antenna numbers across CC-s are specified.

For UE not supporting CA and supporting 1024QAM, the TB success rate shall be higher than 85% when PDSCH is scheduled with FRC in Table 8.7.16-4 according the UE capability. The maximum supported channel bandwidth and MIMO layer are configured during the test.

For UE supporting CA and supporting 1024QAM at least on one CC for a supported CA configuration, the SDR requirements are specified as follows:

- If UE is capable of supporting 256QAM, the TB success rate shall be higher than 85% on each CC when PDSCH-s are scheduled with FRC-s in Table 8.7.16-3 for the transmission with 256QAM and Table 8.7.16-4 for the transmission with 1024QAM according to the reported capability of supported modulation order for the determined CA configuration.
- If UE is not capable of supporting 256QAM, the TB success rate shall be higher than 85% on each CC when PDSCH-s are scheduled with FRC-s in Table 8.7.16-2 for the transmission with 64QAM and Table 8.7.16-4 for the transmission with 1024QAM according to the reported capability of supported modulation order for the determined CA configuration.

For UE supporting 1024 QAM, the SDR requirement with 64QAM and 256QAM only is not applicable.

The CA configuration or band for single carrier, bandwidth combination or bandwidth for single carrier, modulation order on each CC and MIMO layer on each CC are determined by the following procedure.

- Among all the supported CA configurations which support 1024QAM at least on one CC, select one set of {CA configuration or a band, bandwidth combination or bandwidth, modulation order on each CC, MIMO layer on each CC}, which leads to the largest equivalent aggregated bandwidth. The equivalent aggregated bandwidth is defined as

$$B_{agg} = \prod_{i=0}^{N-1} M_i R_i B_i$$

Where  $N$  is the number of CCs,  $R_i \in \{2,4\}$  represents the MIMO layer,  $B_i \in \{5,10,15,20\}$  represents the bandwidths on each CC,  $[M_i \in \{0.75,1,1.25\}]$  is the scaling factor according to the supported modulation order on each CC, where  $M_i = 0.75$  is used if the maximum modulation order of CC  $i$  is 64QAM,  $M_i = 1$  is used if the maximum modulation order of CC  $i$  is 256QAM, and  $M_i = 1.25$  is used if the maximum modulation order of CC  $i$  is 1024QAM.]

- When there are multiple sets of {CA configuration or a band, bandwidth combination or bandwidth, modulation order on each CC, MIMO layer on each CC} which can reach the same equivalent aggregated bandwidth, select one among the sets with the largest number of CCs supporting 1024QAM.
- When there are multiple sets of {CA configuration or a band, bandwidth combination or bandwidth, modulation order on each CC, MIMO layer on each CC} which can reach the same equivalent aggregated bandwidth with the same number of CCs supporting 1024QAM, select one among the sets with the largest number of CCs supporting 4 layer.
- The procedure applies also for the single carrier operating band instead of CA configuration, and bandwidth instead of bandwidth combination.

The TB success rate for single carrier or on each CC for CA is defined as  $100\% * N_{DL\_correct\_rx} / (N_{DL\_newtx} + N_{DL\_retr})$ , where  $N_{DL\_newtx}$  is the number of newly transmitted DL transport blocks,  $N_{DL\_retr}$  is the number of retransmitted DL transport blocks, and  $N_{DL\_correct\_rx}$  is the number of correctly received DL transport blocks. The TB success rate shall be sustained during at least 300 frames.

**Table 8.7.16-2: Per-CC FRC for SDR test (FDD 64QAM)**

MIMO layer	Bandwidth	Reference channel
2 layer	5	R.31-6 FDD
	10	R.31-3A FDD
	15	R.31-5 FDD
	20	R.31-4 FDD
4 layer	5	R.31-10 FDD
	10	R.31-7 FDD
	15	R.31-8 FDD
	20	R.31-9 FDD

**Table 8.7.16-3: Per-CC FRC for SDR test (FDD 256QAM)**

MIMO layer	Bandwidth	Reference channel
2 layer	5	R.68-3 FDD
	10	R.68-2 FDD
	15	R.68-1 FDD
	20	R.68 FDD
4 layer	5	R.68-7 FDD
	10	R.68-4 FDD
	15	R.68-5 FDD
	20	R.68-6 FDD

**Table 8.7.16-4: Per-CC FRC for SDR test (FDD 1024QAM)**

MIMO layer	Bandwidth	Reference channel
2 layer	5	R.105-3 FDD
	10	R.105-2 FDD
	15	R.105-1 FDD
	20	R.105 FDD
4 layer	5	R.105-7 FDD
	10	R.105-6 FDD
	15	R.105-5 FDD
	20	R.105-4 FDD

## 8.7.17 TDD (1024QAM and up to 4 Rx supported)

The common parameters are specified in Table 8.7.17-1 for UE which is capable of supporting 1024QAM.

**Table 8.7.17-1: Common Test Parameters (TDD)**

Parameter	Unit	Value
Transmission mode		3
Uplink downlink configuration		1
Special subframe configuration (Note 1)		4
Cyclic prefix		Normal
Cell ID		0
Inter-TTI Distance		1
Number of HARQ processes per component carrier	Processes	7
Maximum number of HARQ transmission		4
Redundancy version coding sequence		{0,0,1,2} for 64QAM, 256QAM, and 1024QAM
Number of OFDM symbols for PDCCH per component carrier	OFDM symbols	1
Cross carrier scheduling		Not configured
Propagation condition		Static propagation condition No external noise sources are applied
$\hat{E}_s$ at antenna port	dBm/15kHz	-85
Symbols for unused PRBs		OP.1 TDD
Antenna configuration	2 layer CC	2x2 or 2x4
	4 layer CC	4x4
Codebook subset restriction	2 layer CC	10
	4 layer CC	1000
Downlink power allocation	2 layer CC	$\rho_A = -3\text{dB}$ , $\rho_B = -3\text{dB}$ , $\sigma = 0\text{dB}$
	4 layer CC	$\rho_A = -6\text{dB}$ , $\rho_B = -6\text{dB}$ , $\sigma = 3\text{dB}$
Symbols for unused PRBs		OP.1 TDD

The UE capability for 1024QAM is signalled per band or per band combination, hence the SDR tests with the mixed modulation orders and the mixed receiver antenna numbers across CC-s are specified.

For UE not supporting CA and supporting 1024QAM, the TB success rate shall be higher than 85% when PDSCH is scheduled with FRC in Table 8.7.17-4 according the UE capability. The maximum supported channel bandwidth and MIMO layer are configured during the test.

For UE supporting CA and supporting 1024QAM at least on one CC for a supported CA configuration, the SDR requirements are specified as follows:

- If UE is capable of supporting 256QAM, the TB success rate shall be higher than 85% on each CC when PDSCH-s are scheduled with FRC-s in Table 8.7.17-3 for the transmission with 256QAM and Table 8.7.17-4 for the transmission with 1024QAM according to the reported capability of supported modulation order for the determined CA configuration.
- If UE is not capable of supporting 256QAM, the TB success rate shall be higher than 85% on each CC when PDSCH-s are scheduled with FRC-s in Table 8.7.17-2 for the transmission with 64QAM and Table 8.7.17-4 for the transmission with 1024QAM according to the reported capability of supported modulation order for the determined CA configuration.

For UE supporting 1024 QAM, the SDR requirement with 64QAM and 256QAM only is not applicable.

The CA configuration or band for single carrier, bandwidth combination or bandwidth for single carrier, modulation order on each CC and MIMO layer on each CC are determined by the following procedure.

- Among all the supported CA configurations which support 1024QAM at least on one CC, select one set of {CA configuration or a band, bandwidth combination or bandwidth, modulation order on each CC, MIMO layer on each CC}, which leads to the largest equivalent aggregated bandwidth. The equivalent aggregated bandwidth is defined as

$$B_{agg} = \prod_{i=0}^{N-1} M_i R_i B_i$$

Where  $N$  is the number of CCs,  $R_i \in \{2,4\}$  represents the MIMO layer,  $B_i \in \{10,15,20\}$  represents the bandwidths on each CC,  $[M_i \in \{0.75,1,1.25\}]$  is the scaling factor according to the supported modulation order on each CC, where  $M_i = 0.75$  is used if the maximum modulation order of CC  $i$  is 64QAM,  $M_i = 1$  is used if the maximum modulation order of CC  $i$  is 256QAM, and  $M_i = 1.25$  is used if the maximum modulation order of CC  $i$  is 1024QAM.]

- When there are multiple sets of {CA configuration or a band, bandwidth combination or bandwidth, modulation order on each CC, MIMO layer on each CC} which can reach the same equivalent aggregated bandwidth, select one among the sets with the largest number of CCs supporting 1024QAM.
- When there are multiple sets of {CA configuration or a band, bandwidth combination or bandwidth, modulation order on each CC, MIMO layer on each CC} which can reach the same equivalent aggregated bandwidth with the same number of CCs supporting 1024QAM, select one among the sets with the largest number of CCs supporting 4 layer.
- The procedure applies also for the single carrier operating band instead of CA configuration, and bandwidth instead of bandwidth combination.

The TB success rate for single carrier or on each CC for CA is defined as  $100\% * N_{DL\_correct\_rx} / (N_{DL\_newtx} + N_{DL\_retr})$ , where  $N_{DL\_newtx}$  is the number of newly transmitted DL transport blocks,  $N_{DL\_retr}$  is the number of retransmitted DL transport blocks, and  $N_{DL\_correct\_rx}$  is the number of correctly received DL transport blocks. The TB success rate shall be sustained during at least 300 frames.

**Table 8.7.17-2: Per-CC FRC for SDR test(TDD 64QAM)**

MIMO layer	Bandwidth	Reference channel
2 layer	10	R.31-6 TDD
	15	R.31-5 TDD
	20	R.31-4 TDD
4 layer	10	R.31-7 TDD
	15	R.31-8 TDD
	20	R.31-9 TDD

**Table 8.7.17-3: Per-CC FRC for SDR test (TDD 256QAM)**

MIMO layer	Bandwidth	Reference channel
2 layer	10	R.68-2 TDD
	15	R.68-1 TDD
	20	R.68 TDD
4 layer	10	R.68-5 TDD
	15	R.68-6 TDD
	20	R.68-7 TDD

Table 8.7.17-4: Per-CC FRC for SDR test (TDD 1024QAM)

MIMO layer	Bandwidth	Reference channel
2 layer	10	R.105-2 TDD
	15	R.105-1 TDD
	20	R.105 TDD
4 layer	10	R.105-5 TDD
	15	R.105-4 TDD
	20	R.105-3 TDD

### 8.7.18 TDD FDD CA (1024QAM and up to 4 Rx supported)

The common parameters are specified in Table 8.7.18-1 for UE which is capable of supporting 1024QAM.

Table 8.7.18-1: Common Test Parameters (TDD FDD CA)

Parameter	Unit	FDD CC	TDD CC
Transmission mode		3	3
Uplink downlink configuration (Note 1)		N/A	1
Special subframe configuration (Note 2)		N/A	4
Cyclic prefix		Normal	Normal
Cell ID		0	0
Inter-TTI Distance		1	1
Number of HARQ processes per component carrier	Processes	8	7
Maximum number of HARQ transmission		4	4
Redundancy version coding sequence		{0,0,1,2} for 64QAM, 256QAM and 1024QAM	{0,0,1,2} for 64QAM, 256QAM, and 1024QAM
Number of OFDM symbols for PDCCH per component carrier	OFDM symbols	1	1
Cross carrier scheduling		Not configured	Not configured
Propagation condition		Static propagation condition No external noise sources are applied	Static propagation condition No external noise sources are applied
$\hat{E}_s$ at antenna port	dBm/15kHz	-85	-85
Antenna configuration	2 layer CC	2x2 or 2x4	2x2 or 2x4
	4 layer CC	4x4	4x4
Codebook subset restriction	2 layer CC	10	10
	4 layer CC	1000	1000
Downlink power allocation	2 layer CC	$\rho_A = -3\text{dB}$ , $\rho_B = -3\text{dB}$ , $\sigma = 0\text{dB}$	$\rho_A = -3\text{dB}$ , $\rho_B = -3\text{dB}$ , $\sigma = 0\text{dB}$
	4 layer CC	$\rho_A = -6\text{dB}$ , $\rho_B = -6\text{dB}$ , $\sigma = 3\text{dB}$	$\rho_A = -6\text{dB}$ , $\rho_B = -6\text{dB}$ , $\sigma = 3\text{dB}$
Symbols for unused PRBs		OP.1 FDD	OP.1 TDD
Note 1:	as specified in Table 4.2-2 in TS 36.211 [4].		
Note 2:	as specified in Table 4.2-1 in TS 36.211 [4].		

The UE capability for 1024QAM is signalled per band or per band combination, hence the SDR tests with the mixed modulation orders and the mixed receiver antenna numbers across CC-s are specified.

For UE not supporting CA and supporting 1024QAM, the TB success rate shall be higher than 85% when PDSCH is scheduled with FRC in Table 8.7.18-4 according to the UE capability. The maximum supported channel bandwidth and MIMO layer are configured during the test.

For UE supporting CA and supporting 1024QAM at least on one CC for a supported CA configuration, the SDR requirements are specified as follows:

- If UE is capable of supporting 256QAM, the TB success rate shall be higher than 85% on each CC when PDSCH-s are scheduled with FRC-s in Table 8.7.18-3 for the transmission with 256QAM and Table 8.7.18-4 for the transmission with 1024QAM according to the reported capability of supported modulation order for the determined CA configuration.
- If UE is not capable of supporting 256QAM, the TB success rate shall be higher than 85% on each CC when PDSCH-s are scheduled with FRC-s in Table 8.7.18-2 for the transmission with 64QAM and Table 8.7.18-4 for the transmission with 1024QAM according to the reported capability of supported modulation order for the determined CA configuration.

For UE supporting 1024 QAM, the SDR requirement with 64QAM and 256QAM only is not applicable.

The CA configuration or band for single carrier, bandwidth combination or bandwidth for single carrier, modulation order on each CC and MIMO layer on each CC are determined by the following procedure.

- Among all the supported CA configurations which support 1024QAM at least on one CC, select one set of {CA configuration or a band, bandwidth combination or bandwidth, modulation order on each CC, MIMO layer on each CC}, which leads to the largest equivalent aggregated bandwidth. The equivalent aggregated bandwidth is defined as

$$B_{agg} = \prod_{i=0}^{N-1} M_i R_i B_i$$

Where  $N$  is the number of CCs,  $R_i \in \{2,4\}$  represents the MIMO layer,  $B_i \in \{5,10,15,20\}$  represents the bandwidths on each FDD CC and  $B_i \in \{10,15,20\}$  represents the bandwidths on each FDD CC,

[  $M_i \in \{0.75,1,1.25\}$  is the scaling factor according to the supported modulation order on each CC, where  $M_i = 0.75$  is used if the maximum modulation order of CC  $i$  is 64QAM,  $M_i = 1$  is used if the maximum modulation order of CC  $i$  is 256QAM, and  $M_i = 1.25$  is used if the maximum modulation order of CC  $i$  is 1024QAM.]

- When there are multiple sets of {CA configuration or a band, bandwidth combination or bandwidth, modulation order on each CC, MIMO layer on each CC} which can reach the same equivalent aggregated bandwidth, select one among the sets with the largest number of CCs supporting 1024QAM.
- When there are multiple sets of {CA configuration or a band, bandwidth combination or bandwidth, modulation order on each CC, MIMO layer on each CC} which can reach the same equivalent aggregated bandwidth with the same number of CCs supporting 1024QAM, select one among the sets with the largest number of CCs supporting 4 layer.
- The procedure applies also for the single carrier operating band instead of CA configuration, and bandwidth instead of bandwidth combination.

The TB success rate for single carrier or on each CC for CA is defined as  $100\% * N_{DL\_correct\_rx} / (N_{DL\_newtx} + N_{DL\_retr})$ , where  $N_{DL\_newtx}$  is the number of newly transmitted DL transport blocks,  $N_{DL\_retr}$  is the number of retransmitted DL transport blocks, and  $N_{DL\_correct\_rx}$  is the number of correctly received DL transport blocks. The TB success rate shall be sustained during at least 300 frames.

**Table 8.7.18-2: Per-CC FRC for SDR test (TDD-FDD 64QAM)**

MIMO layer	Bandwidth	FDD Reference channel	TDD Reference channel
2 layer	5	R.31-6 FDD	N/A
	10	R.31-3A FDD	R.31-6 TDD
	15	R.31-5 FDD	R.31-5 TDD
	20	R.31-4 FDD	R.31-4 TDD
4 layer	5	R.31-10 FDD	N/A
	10	R.31-7 FDD	R.31-7 TDD
	15	R.31-8 FDD	R.31-8 TDD
	20	R.31-9 FDD	R.31-9 TDD

**Table 8.7.18-3: Per-CC FRC for SDR test (TDD-FDD 256QAM)**

MIMO layer	Bandwidth	FDD Reference channel	TDD Reference channel
2 layer	5	R.68-3 FDD	N/A
	10	R.68-2 FDD	R.68-2 TDD
	15	R.68-1 FDD	R.68-1 TDD
	20	R.68 FDD	R.68 TDD
4 layer	5	R.68-7 FDD	N/A
	10	R.68-4 FDD	R.68-5 TDD
	15	R.68-5 FDD	R.68-6 TDD
	20	R.68-6 FDD	R.68-7 TDD

**Table 8.7.18-4: Per-CC FRC for SDR test (TDD-FDD 1024QAM)**

MIMO layer	Bandwidth	FDD Reference channel	TDD Reference channel
2 layer	5	R.105-3 FDD	N/A
	10	R.105-2 FDD	R.105-2 TDD
	15	R.105-1 FDD	R.105-1 TDD
	20	R.105 FDD	R.105 TDD
4 layer	5	R.105-7 FDD	N/A
	10	R.105-6 FDD	R.105-5 TDD
	15	R.105-5 FDD	R.105-4 TDD
	20	R.105-4 FDD	R.105-3 TDD

### 8.7.19 TDD (8 Rx)

The parameters specified in Table 8.7.19-1 are valid for all TDD tests for 8Rx capable UEs unless otherwise stated. For 2/4 layer carrier configurations, please refer to Table 8.7.10-1. 8 layer carrier configuration is specified in Table 8.7.19-1.



Table 8.7.19-1: Common Test Parameters for 8 Layer (TDD)

Parameter	Unit	Test 1	
Downlink power allocation	$\rho_A$	dB	0
	$\rho_B$	dB	0 (Note 1)
	$\sigma$	dB	-3
Uplink downlink configuration		1	
Special subframe configuration		4	
Cell-specific reference signals		Antenna ports 0,1	
CSI reference signals		Antenna ports 15,...,22	
Beamforming model		Annex B.4.3(Note 3, 4)	
CSI-RS periodicity and subframe offset $T_{\text{CSI-RS}} / \Delta_{\text{CSI-RS}}$	Subframes	5 / 4	
CSI reference signal configuration		3	
Zero-power CSI-RS configuration $l_{\text{CSI-RS}} / \text{ZeroPowerCSI-RS}$ bitmap	Subframes / bitmap	4 / 0010000000000000	
$N_{oc}$ at antenna port	dBm/15kHz	-98	
Symbols for unused PRBs		OP.1 TDD	
Cyclic prefix		Normal	
Cell ID		0	
Inter-TTI Distance		1	
Number of HARQ processes per component carrier	Processes	7	
Maximum number of HARQ transmission		4	
Redundancy version coding sequence		{0,0,1,2} for 64QAM and 256QAM	
Number of allocated resource blocks (Note 2)	PRB	50	
Number of OFDM symbols for PDCCH per component carrier	OFDM symbols	1	
Propagation condition		Static propagation condition No external noise sources are applied	
Simultaneous transmission		No	
PDSCH transmission mode		9	
Precoding granularity		50	
PMI delay		10 or 11	
Reporting interval		1 or 4	
Reporting mode		PUSCH 3-1	
alternativeCodeBookEnabledFor4TX-r12		False	
CodeBookSubsetRestriction bitmap		0x0000 0000 0000 0010 0000 0000 0000	
Note 1: $P_B = 1$ . Note 2: 50 resource blocks are allocated in sub-frames 4,9 and 41 resource blocks (RB0–RB20 and RB30–RB49) are allocated in sub-frame 0 and the DwPTS portion of sub-frames 1,6. Note 3: The precoder in clause B.4.3 follows UE recommended PMI. Note 4: If the UE reports in an available uplink reporting instance at subframe SF#n based on PMI estimation at a downlink SF not later than SF#(n-4), this reported PMI cannot be applied at the eNB downlink before SF#(n+4).			

For UE not supporting 256QAM, the TB success rate shall be higher than 85% when PDSCH are scheduled with FRC in Table 8.7.19-2 with the downlink physical channel setup according to Annex C.3.2.

For UE supporting 256QAM, the TB success rate shall be higher than 85% when PDSCH are scheduled with FRC in Table 8.7.19-3 with the downlink physical channel setup according to Annex C.3.2. For UE supporting 256QAM, the requirement with 64QAM is not applicable.

The TB success rate is defined as  $100\% \cdot N_{\text{DL\_correct\_rx}} / (N_{\text{DL\_newtx}} + N_{\text{DL\_retr}})$ , where  $N_{\text{DL\_newtx}}$  is the number of newly transmitted DL transport blocks,  $N_{\text{DL\_retr}}$  is the number of retransmitted DL transport blocks, and  $N_{\text{DL\_correct\_rx}}$  is the number of correctly received DL transport blocks. The TB success rate shall be sustained during at least 300 frames.

Table 8.7.19-2: Per-CC FRC for SDR test (TDD 64QAM)

MIMO layer	Bandwidth	Reference channel
2 layer	10	R.31-6 TDD
	15	R.31-5 TDD
	20	R.31-4 TDD
4 layer	10	R.31-7 TDD
	15	R.31-8 TDD
	20	R.31-9 TDD
8 layer	10	R.31-10 TDD
	15	R.31-11 TDD
	20	R.31-12 TDD

Table 8.7.19-3: Per-CC FRC for SDR test (TDD 256QAM)

MIMO layer	Bandwidth	Reference channel
2 layer	10	R.68-2 TDD
	15	R.68-1 TDD
	20	R.68 TDD
4 layer	10	R.68-5 TDD
	15	R.68-6 TDD
	20	R.68-7 TDD
8 layer	10	R.68-8 TDD
	15	R.68-9 TDD
	20	R.68-10 TDD

CA configuration, bandwidth combination and MIMO layer on each CC is determined by following procedure.

- Select the set(s) of {CA configuration, bandwidth combination, MIMO layer} among all the supported CA configurations that leads to the largest equivalent aggregated bandwidth which does not cause the transport block bits within a TTI to exceed the capability of the category of UE under test when the defined reference channel applies on each CC. The equivalent aggregated bandwidth is defined as

$$B_{agg} = \prod_{i=0}^{N-1} a(R_i) R_i B_i$$

Where  $N$  is the number of CCs,  $R_i \in \{2, 4, 8\}$  and  $B_i \in \{5, 10, 15, 20\}$  are MIMO layer and bandwidth of CC  $i$ . And  $a(R_i) = 1$  for  $R_i = 2, 4$  and  $a(R_i) = 0.75$  for  $R_i = 8$

- The procedure applies also for single carrier using operating band instead of CA configuration, and bandwidth instead of bandwidth combination.

## 8.8 Demodulation of EPDCCH

The receiver characteristics of the EPDCCH are determined by the probability of miss-detection of the Downlink Scheduling Grant (Pm-dsg). For the distributed transmission tests in 8.8.1, EPDCCH and PCFICH are tested jointly, i.e. a miss detection of PCFICH implies a miss detection of EPDCCH. For other tests, EPDCCH and PCFICH are not tested jointly.

### 8.8.1 Distributed Transmission

#### 8.8.1.1 FDD

The parameters specified in Table 8.8.1.1-1 are valid for all FDD distributed EPDCCH tests unless otherwise stated.

**Table 8.8.1.1-1: Test Parameters for Distributed EPDCCH**

Parameter		Unit	Value
Number of PDCCH symbols		symbols	2 (Note 1)
PHICH duration			Normal
Unused RE-s and PRB-s			OCNG
Cell ID			0
Downlink power allocation	$\rho_A$	dB	-3
	$\rho_B$	dB	-3
	$\sigma$	dB	0
	$\delta$	dB	3
$N_{oc}$ at antenna port		dBm/15 kHz	-98
Cyclic prefix			Normal
Subframe Configuration			Non-MBSFN
Precoder Update Granularity	PRB		1
	ms		1
Beamforming Pre-Coder			Annex B. 4.4
Cell Specific Reference Signal			Port 0 and 1
Number of EPDCCH Sets Configured			2 (Note 2)
Number of PRB per EPDCCH Set			4 (1 <sup>st</sup> Set)
			8 (2 <sup>nd</sup> Set)
EPDCCH Subframe Monitoring			NA
PDSCH TM			TM3
DCI Format			2A
Note 1: The starting symbol for EPDCCH is derived from the PCFICH. RRC signalling <i>epdcch-StartSymbol-r11</i> is not configured.			
Note 2: The two sets are distributed EPDCCH sets and non-overlapping with PRB = {3, 17, 31, 45} for the first set and PRB = {0, 7, 14, 21, 28, 35, 42, 49} for the second set. EPDCCH is scheduled in the first set for Test 1 and second set for Test 2, respectively. Both sets are always configured.			

For the parameters specified in Table 8.8.1.1-1 the average probability of a missed downlink scheduling grant (Pm-dsg) shall be below the specified value in Table 8.8.1.1-2. The downlink physical setup is in accordance with Annex C.3.2.

**Table 8.8.1.1-2: Minimum performance Distributed EPDCCH**

Test number	Bandwidth	Aggregation level	Reference Channel	OCNG Pattern	Propagation Condition	Antenna configuration and correlation Matrix	Reference value	
							Pm-dsg (%)	SNR (dB)
1	10 MHz	4 ECCE	R.55 FDD	OP.7 FDD	EVA5	2 x 2 Low	1	2.60
2	10 MHz	16 ECCE	R.56 FDD	OP.7 FDD	EVA70	2 x 2 Low	1	-3.20

8.8.1.1.1 Void

**Table 8.8.1.1.1-1: Void**

8.8.1.2 TDD

The parameters specified in Table 8.8.1.2-1 are valid for all TDD distributed EPDCCH tests unless otherwise stated.

**Table 8.8.1.2-1: Test Parameters for Distributed EPDCCH**

Parameter		Unit	Value
Number of PDCCH symbols		symbols	2 (Note 1)
PHICH duration			Normal
Unused RE-s and PRB-s			OCNG
Cell ID			0
Downlink power allocation	$\rho_A$	dB	-3
	$\rho_B$	dB	-3
	$\sigma$	dB	0
	$\delta$	dB	3
$N_{oc}$ at antenna port		dBm/15 kHz	-98
Cyclic prefix			Normal
Subframe Configuration			Non-MBSFN
Precoder Update Granularity	PRB		1
	ms		1
Beamforming Pre-Coder			Annex B. 4.4
Cell Specific Reference Signal			Port 0 and 1
Number of EPDCCH Sets Configured			2 (Note 2)
Number of PRB per EPDCCH Set			4 (1 <sup>st</sup> Set)
			8 (2 <sup>nd</sup> Set)
EPDCCH Subframe Monitoring			NA
PDSCH TM			TM3
DCI Format			2A
TDD UL/DL Configuration			0
TDD Special Subframe			1 (Note 3)
<p>Note 1: The starting symbol for EPDCCH is derived from the PCFICH. RRC signalling <i>epdcch-StartSymbol-r11</i> is not configured.</p> <p>Note 2: The two sets are distributed EPDCCH sets and non-overlapping with PRB = {3, 17, 31, 45} for the first set and PRB = {0, 7, 14, 21, 28, 35, 42, 49} for the second set. EPDCCH is scheduled in the first set for Test 1 and second set for Test 2, respectively. Both sets are always configured.</p> <p>Note 3: Demodulation performance is averaged over normal and special subframe.</p>			

For the parameters specified in Table 8.8.1.2-1 the average probability of a missed downlink scheduling grant ( $P_m$ -dsg) shall be below the specified value in Table 8.8.1.2-2. The downlink physical setup is in accordance with Annex C.3.2.

**Table 8.8.1.2-2: Minimum performance Distributed EPDCCH**

Test number	Bandwidth	Aggregation level	Reference Channel	OCNG Pattern	Propagation Condition	Antenna configuration and correlation Matrix	Reference value	
							$P_m$ -dsg (%)	SNR (dB)
1	10 MHz	4 ECCE	R.55 TDD	OP.7 TDD	EVA5	2 x 2 Low	1	2.80
2	10 MHz	16 ECCE	R.56 TDD	OP.7 TDD	EVA70	2 x 2 Low	1	-3.10

8.8.1.2.1 Void

**Table 8.8.1.2.1-1: Void**

## 8.8.2 Localized Transmission with TM9

### 8.8.2.1 FDD

The parameters specified in Table 8.8.2.1-1 are valid for all FDD TM9 localized ePDCCH tests unless otherwise stated.

Table 8.8.2.1-1: Test Parameters for Localized EPDCCH with TM9

Parameter		Unit	Value
Number of PDCCH symbols		symbols	1 (Note 1)
EPDCCH starting symbol		symbols	2 (Note 1)
PHICH duration			Normal
Unused RE-s and PRB-s			OCNG
Cell ID			0
Downlink power allocation	$\rho_A$	dB	0
	$\rho_B$	dB	0
	$\sigma$	dB	-3
	$\delta$	dB	0
$N_{oc}$ at antenna port		dBm/15 kHz	-98
Cyclic prefix			Normal
Subframe Configuration			Non-MBSFN
Precoder Update Granularity	PRB		1
	ms		1
Beamforming Pre-Coder			Annex B.4.5
Cell Specific Reference Signal			Port 0 and 1
CSI-RS Reference Signal			Port 15 and 16
CSI-RS reference signal resource configuration			0
CSI reference signal subframe configuration $l_{CSI-RS}$			2
ZP-CSI-RS configuration bitmap			0000010000000000
ZP-CSI-RS subframe configuration $l_{ZP-CSI-RS}$			2
Number of EPDCCH Sets			2 (Note 2)
EPDCCH Subframe Monitoring pattern $subframePatternConfig-r11$			1111111110 1111111101 1111111011 1111110111 (Note 3)
PDSCH TM			TM9
Note 1: The starting symbol for EPDCCH is signalled with $epdcch-StartSymbol-r11$ . However, CFI is set to 1.			
Note 2: The first set is distributed transmission with PRB = {0, 49} and the second set is localized transmission with PRB = {0, 7, 14, 21, 28, 35, 42, 49}. ePDCCH is scheduled in the second set for all tests.			
Note 3: EPDCCH is scheduled in every SF. UE is required to monitor ePDCCH for UE-specific search space only in SFs configured by $subframePatternConfig-r11$ . Legacy PDCCH is not scheduled.			

For the parameters specified in Table 8.8.2.1-1 the average probability of a missed downlink scheduling grant ( $P_{m-dsg}$ ) shall be below the specified value in Table 8.8.2.1-2. EPDCCH subframe monitoring is configured and the subframe monitoring requirement in EPDCCH restricted subframes is statDTX of 99.9%.

The downlink physical setup is in accordance with Annex C.3.2.

Table 8.8.2.1-2: Minimum performance Localized EPDCCH with TM9

Test number	Bandwidth	Aggregation level	Reference Channel	OCNG Pattern	Propagation Condition	Antenna configuration and correlation Matrix	Reference value	
							$P_{m-dsg}$ (%)	SNR (dB)
1	10 MHz	2 ECCE	R.57 FDD	OP.7 FDD	EVA5	2 x 2 Low	1	12.2
2	10 MHz	8 ECCE	R.58 FDD	OP.7 FDD	EVA5	2 x 2 Low	1	2.5

8.8.2.1.1 Void

**Table 8.8.2.1.1-1: Void**

8.8.2.1.2 Void

**Table 8.8.2.1.2-1: Void****Table 8.8.2.1.2-2: Void****Table 8.8.2.1.2-3: Void**

8.8.2.2 TDD

The parameters specified in Table 8.8.2.2-1 are valid for all TDD TM9 localized ePDCCH tests unless otherwise stated.

**Table 8.8.2.2-1: Test Parameters for Localized EPDCCH with TM9**

Parameter	Unit	Value	
Number of PDCCH symbols	symbols	1 (Note 1)	
EPDCCH starting symbol	symbols	2 (Note 1)	
PHICH duration		Normal	
Unused RE-s and PRB-s		OCNG	
Cell ID		0	
Downlink power allocation	$\rho_A$	dB	0
	$\rho_B$	dB	0
	$\sigma$	dB	-3
	$\delta$	dB	0
$N_{oc}$ at antenna port	dBm/15 kHz	-98	
Cyclic prefix		Normal	
Subframe Configuration		Non-MBSFN	
Precoder Update Granularity	PRB	1	
	ms	1	
Beamforming Pre-Coder		Annex B.4.5	
Cell Specific Reference Signal		Port 0 and 1	
CSI-RS Reference Signal		Port 15 and 16	
CSI-RS reference signal resource configuration		0	
CSI reference signal subframe configuration $l_{CSI-RS}$		0	
ZP-CSI-RS configuration bitmap		0000010000000000	
ZP-CSI-RS subframe configuration $l_{ZP-CSI-RS}$		0	
Number of EPDCCH Sets		2 (Note 2)	
EPDCCH Subframe Monitoring pattern <i>subframePatternConfig-r11</i>		1100011000 1100010000 1100011000 1100001000 1100011000 1000011000 1100011000 (Note 3)	
PDSCH TM		TM9	
TDD UL/DL Configuration		0	
TDD Special Subframe		1 (Note 4)	
Note 1:	The starting symbol for EPDCCH is signalled with <i>epdch-StartSymbol-r11</i> . However, CFI is set to 1.		
Note 2:	The first set is distributed transmission with PRB = {0, 49} and the second set is localized transmission with PRB = {0, 7, 14, 21, 28, 35, 42, 49}. ePDCCH is scheduled in the second set for all tests.		

Note 3:	EPDCCH is scheduled in every SF. UE is required to monitor ePDCCH for UE-specific search space only in SFs configured by <i>subframePatternConfig-r11</i> . Legacy PDCCH is not scheduled.
Note 4:	Demodulation performance is averaged over normal and special subframe.

For the parameters specified in Table 8.8.2.2-1 the average probability of a missed downlink scheduling grant (Pm-dsg) shall be below the specified value in Table 8.2.2.2-2. EPDCCH subframe monitoring is configured and the subframe monitoring requirement in EPDCCH restricted subframes is statDTX of 99.9%.

The downlink physical setup is in accordance with Annex C.3.2.

**Table 8.8.2.2-2: Minimum performance Localized EPDCCH with TM9**

Test number	Bandwidth	Aggregation level	Reference Channel	OCNG Pattern	Propagation Condition	Antenna configuration and correlation Matrix	Reference value	
							Pm-dsg (%)	SNR (dB)
1	10 MHz	2 ECCE	R.57 TDD	OP.7 TDD	EVA5	2 x 2 Low	1	12.8
2	10 MHz	8 ECCE	R.58 TDD	OP.7 TDD	EVA5	2 x 2 Low	1	2.0

8.8.2.2.1 Void

**Table 8.8.2.2.1-1: Void**

8.8.2.2.2 Void

**Table 8.8.2.2.2-1: Void**

**Table 8.8.2.2.2-2: Void**

**Table 8.8.2.2.2-3: Void**

## 8.8.3 Localized transmission with TM10 Type B quasi co-location type

8.8.3.1 FDD

For the parameters specified in Table 8.8.3.1-1 the average probability of a missed downlink scheduling grant (Pm-dsg) shall be below the specified values in Table 8.8.3.1-2. In Table 8.8.3.1-1, transmission point 1 (TP 1) is the serving cell. The downlink physical setup is in accordance with Annex C.3.2.

**Table 8.8.3.1-1: Test Parameters for Localized Transmission TM10 Type B quasi co-location type**



Parameter		Unit	Test 1		Test 2	
			TP 1	TP 2	TP 1	TP 2
PHICH duration			Normal			
Downlink power allocation	$\rho_A$	dB	0			
	$\rho_B$	dB	0			
	$\sigma$	dB	-3			
	$\delta$	dB	0			
$\hat{E}_s/N_{oc}$		dB	0dB power imbalance is considered between TP 1 and TP 2,	Reference value in Table 8.8.3.1-2	Reference value in Table 8.8.3.1-2	Reference value in Table 8.8.3.1-2
$N_{oc}$ at antenna port		dBm/15kHz	-98			
Bandwidth		MHz	10	10	10	10
Number of configured EPDCCH Sets			2 (Note 1)		2 (Note1)	
EPDCCH-PRB-Set ID (setConfigId)			0	1	0	1
Transmission type of EPDCCH-PRB-set			Localized	Localized	Localized	Localized
Number of PRB pair per EPDCCH-PRB-set		PRB	8	8	8	8
EPDCCH beamforming model			Annex B.4.5	Annex B.4.5	Annex B.4.5	Annex B.4.5
PDSCH transmission mode			TM10	TM10	TM10	TM10
PDSCH transmission scheduling			Blanked in all the subframes	Transmit in all the subframes	Probability of occurrence of PDSCH transmission is 30% (Note 3)	Probability of occurrence of PDSCH transmission is 70% (Note 3)
Non-zero power CSI reference signal (NZPId=1)	CSI reference signal configuration		N/A	0	N/A	0
	CSI reference signal subframe configuration $l_{CSI-RS}$		N/A	2	N/A	2
Non-zero power CSI reference signal (NZPId=2)	CSI reference signal configuration		N/A	N/A	10	N/A
	CSI reference signal subframe configuration $l_{CSI-RS}$		N/A	N/A	2	N/A
Zero power CSI reference signal (ZPId=1)	CSI-RS Configuration list (ZeroPowerCSI-RS bitmap)	Bitmap	N/A	000001000000000	N/A	100001000000000
	CSI-RS subframe configuration $l_{CSI-RS}$		N/A	2	N/A	2
Zero power CSI reference signal (ZPId=2)	CSI-RS Configuration list (ZeroPowerCSI-RS bitmap)	Bitmap	N/A	N/A	100001000000000	N/A
	CSI-RS subframe configuration $l_{CSI-RS}$		N/A	N/A	2	N/A
PQI set 0 (Note 4)	Non-Zero power CSI RS Identity (NZPId)		N/A	1	N/A	1

	Zero power CSI RS Identity (ZPId)		N/A	1	N/A	1
PQI set 1 (Note 4)	Non-Zero power CSI RS Identity (NZPId)		N/A	N/A	2	N/A
	Zero power CSI RS Identity (ZPId)		N/A	N/A	2	N/A
Number of PDCCH symbols	Symbols	1 (Note 2)				
EPDCCH starting position		pdsch-Start-r11=2 (Note 2)	pdsch-Start-r11=2 (Note 2)	pdsch-Start-r11=2 (Note 2)	pdsch-Start-r11=2 (Note 2)	
Subframe configuration		Non-MBSFN	Non-MBSFN	Non-MBSFN	Non-MBSFN	
Time offset between TPs	$\mu$ s	N/A	2	N/A	2	
Frequency shift between TPs	Hz	N/A	200	N/A	200	
Cell ID		0	126	0	126	
Note 1:	Resource blocks $n_{PRB} = 0, 7, 14, 21, 28, 35, 42, 49$ are allocated for both the first set and the second set.					
Note 2:	The starting OFDM symbol for EPDCCH is determined from the higher layer signalling pdsch-Start-r11. And CFI is set to 1.					
Note 3:	The TP from which PDSCH is transmitted shall be randomly determined independently for each subframe. Probabilities of occurrence of PDSCH transmission from TP 1 and TP 2 are specified.					
Note 4:	For PQI set 0, PDSCH and EPDCCH are transmitted from TP 2. For PQI set 1, PDSCH and EPDCCH are transmitted from TP1. EPDCCH and PDSCH are transmitted from same TP.					

Table 8.8.3.1-2: Minimum Performance

Test number	Aggregation level	Reference Channel	OCNG Pattern	Propagation Condition	Antenna configuration and correlation Matrix	Reference value	
						Pm-dsg (%)	SNR (dB)
1	2 ECCE	R.59 FDD	OP.7 FDD	EVA5	2 x 2 Low	1	13.4
2	2 ECCE	R.59 FDD	OP.7 FDD	EVA5	2 x 2 Low	1	13.4

### 8.8.3.2 TDD

For the parameters specified in Table 8.8.3.2-1 the average probability of a missed downlink scheduling grant (Pm-dsg) shall be below the specified values in Table 8.8.3.2-2. In Table 8.8.3.2-1, transmission point 1 (TP1) is the serving cell. The downlink physical setup is in accordance with Annex C.3.2.

**Table 8.8.3.2-1: Test Parameters for Localized Transmission TM10 Type B quasi co-location type**

Parameter	Unit	Test 1		Test 2	
		TP 1	TP 2	TP 1	TP 2
PHICH duration		Normal			
Downlink power allocation	$\rho_A$	0			
	$\rho_B$	0			
	$\sigma$	-3			
	$\delta$	0			
$\hat{E}_s/N_{oc}$	dB	0dB power imbalance is considered between TP 1 and TP 2,	Reference value in Table 8.8.3.2-2	Reference value in Table 8.8.3.2-2	Reference value in Table 8.8.3.2-2
$N_{oc}$ at antenna port	dBm/15kHz	-98			
Bandwidth	MHz	10	10	10	10
Number of EPDCCH Sets		2 (Note 1)		2 (Note1)	
EPDCCH-PRB-Set ID (setConfigId)		0	1	0	1
Transmission type of EPDCCH-PRB-set		Localized	Localized	Localized	Localized
Number of PRB pair per EPDCCH-PRB-set	PRB	8	8	8	8
EPDCCH beamforming model		Annex B.4.5	Annex B.4.5	Annex B.4.5	Annex B.4.5
PDSCH transmission mode		TM10	TM10	TM10	TM10
PDSCH transmission scheduling		Blanked in all the subframes	Transmit in all the subframes	Probability of occurrence of PDSCH transmission is 30% (Note 3)	Probability of occurrence of PDSCH transmission is 70% (Note 3)
CSI reference signal configurations		Antenna ports 15,16	Antenna ports 15,16	Antenna ports 15,16	Antenna ports 15,16
Non-zero power CSI reference signal (NZPId=1)	CSI reference signal configuration	N/A	0	N/A	0
	CSI reference signal subframe configuration $l_{CSI-RS}$	N/A	0	N/A	0
Non-zero power CSI reference signal (NZPId=2)	CSI reference signal configuration	N/A	N/A	10	N/A
	CSI reference signal subframe configuration $l_{CSI-RS}$	N/A	N/A	0	N/A
Zero power CSI reference signal (ZPId=1)	CSI-RS Configuration list (ZeroPowerCSI-RS bitmap)	Bitmap	N/A	000001000000000	100001000000000
	CSI-RS subframe configuration $l_{CSI-RS}$		N/A	0	0
Zero power CSI reference signal (ZPId=2)	CSI-RS Configuration list (ZeroPowerCSI-RS bitmap)	Bitmap	N/A	N/A	100001000000000
	CSI-RS subframe configuration $l_{CSI-RS}$		N/A	N/A	0
PQI set 0 (Note 4)	Non-Zero power CSI RS Identity (NZPId)		N/A	1	N/A
					1

	Zero power CSI RS Identity (ZPId)		N/A	1	N/A	1
PQI set 1 (Note 4)	Non-Zero power CSI RS Identity (NZPId)		N/A	N/A	2	N/A
	Zero power CSI RS Identity (ZPId)		N/A	N/A	2	N/A
Number of PDCCH symbols	Symbols	1 (Note 2)				
EPDCCH starting position		pdsch-Start-r11=2 (Note 2)	pdsch-Start-r11=2 (Note 2)	pdsch-Start-r11=2 (Note 2)	pdsch-Start-r11=2 (Note 2)	
Subframe configuration		Non-MBSFN	Non-MBSFN	Non-MBSFN	Non-MBSFN	
Time offset between TPs	$\mu$ s	N/A	2	N/A	2	
Frequency shift between TPs	Hz	N/A	200	N/A	200	
Cell ID		0	126	0	126	
TDD UL/DL configuration		0				
TDD special subframe		1				
Note 1:	Resource blocks $n_{PRB} = 0, 7, 14, 21, 28, 35, 42, 49$ are allocated for both the first set and the second set.					
Note 2:	The starting OFDM symbol for EPDCCH is determined from the higher layer signalling pdsch-Start-r11. And CFI is set to 1.					
Note 3:	The TP from which PDSCH is transmitted shall be randomly determined independently for each subframe. Probabilities of occurrence of PDSCH transmission from TP 1 and TP 2 are specified.					
Note 4:	For PQI set 0, PDSCH and EPDCCH are transmitted from TP 2. For PQI set 1, PDSCH and EPDCCH are transmitted from TP1. EPDCCH and PDSCH are transmitted from same TP.					

Table 8.8.3.2-2: Minimum Performance

Test number	Aggregation level	Reference Channel	OCNG Pattern	Propagation Condition	Antenna configuration and correlation Matrix	Reference value	
						Pm-dsg (%)	SNR (dB)
1	2 ECCE	R.59 TDD	OP.7 TDD	EVA5	2 x 2 Low	1	13.6
2	2 ECCE	R.59 TDD	OP.7 TDD	EVA5	2 x 2 Low	1	13.6

## 8.8.4 Enhanced Downlink Control Channel Performance Requirements Type A - Localized Transmission with CRS Interference Model

### 8.8.4.1 FDD

For the parameters specified in Table 8.8.4.1-1 the average probability of a missed downlink scheduling grant (Pm-dsg) shall be below the specified value in Table 8.8.4.1-2. The purpose of this test is to verify the localized EPDCCH performance, when the EPDCCH transmission in the serving cell is interfered by the CRS of the interfering cells, applying the CRS interference model defined in clause B.6.5. In Table 8.8.4.1-1, Cell 1 is the serving cell, and Cell 2 and Cell 3 are the aggressor cells. The downlink physical setup is in accordance with Annex C.3.2 for each of Cell 1, Cell 2 and Cell 3, respectively. The CRS assistance information [7] is provided and includes Cell 2 and Cell 3.

Table 8.8.4.1-1: Test Parameters for EPDCCH

Parameter		Unit	Cell 1	Cell 2	Cell 3
Number of PDCCH symbols		symbols	1 (Note 1)	2	2
EPDCCH starting symbol		symbols	2 (Note 1)	N/A	N/A
PHICH duration			Normal	Normal	Normal
Unused RE-s and PRB-s			OCNG	N/A	N/A
Cell ID			0	1	6
Downlink power allocation	$\rho_A$	dB	0	-3	-3
	$\rho_B$	dB	0	-3	-3
	$\sigma$	dB	-3	0	0
	$\delta$	dB	0	0	0
Cell-specific reference signals			Antenna ports 0,1	Antenna ports 0,1	Antenna ports 0,1
$N_{oc}$ at antenna port		dBm/15kHz	-98		
$\bar{E}_s/N_{oc}$		dB	N/A	13.91	3.34
$BW_{channel}$		MHz	10	10	10
Cyclic Prefix			Normal	Normal	Normal
Subframe Configuration			Non-MBSFN	Non-MBSFN	Non-MBSFN
EPDCCH Precoder Update Granularity	PRB		1	N/A	N/A
	ms		1	N/A	N/A
EPDCCH Beamforming Pre-Coder			Annex B. 4.5	N/A	N/A
CSI-RS Reference Signal			Port 15 and 16	N/A	N/A
CSI-RS reference signal resource configuration			0	N/A	N/A
CSI reference signal subframe configuration $l_{CSI-RS}$			2	N/A	N/A
ZP-CSI-RS configuration bitmap			00001000000 0000	N/A	N/A
ZP-CSI-RS subframe configuration $l_{ZP-CSI-RS}$			2	N/A	N/A
Number of EPDCCH Sets			1	N/A	N/A
EPDCCH Set type			Localized	N/A	N/A
Number of PRB per EPDCCH Set			8	N/A	N/A
EPDCCH Set PRBs			0, 7, 14, 21, 28, 35, 42, 49	N/A	N/A
PDSCH TM			TM9	N/A	N/A
Interference model			N/A	As specified in clause B.6.5	As specified in clause B.6.5
Time offset to cell 1		$\mu$ s	N/A	2	3
Frequency offset to cell 1		Hz	N/A	200	300
Note 1: The starting symbol for EPDCCH is signalled with <i>epdcch-StartSymbol-r11</i> . CFI is set to 1.					
Note 2: EPDCCH is scheduled in every subframe. EPDCCH Subframe Monitoring pattern is not configured.					

Table 8.8.4.1-2: Minimum performance for EPDCCH for enhanced downlink control channel performance requirements Type A

Test number	Bandwidth	Aggregation level	Reference Channel	OCNG Pattern	Propagation Condition	Antenna configuration and correlation Matrix	Reference value	
							Pm-dsg (%)	SNR (dB)
1	10 MHz	2 ECCE	R.57 FDD	OP.7 FDD	EPA5	2 x 2 Low	1	13.4

## 8.8.4.2 TDD

For the parameters specified in Table 8.8.4.1-1 the average probability of a missed downlink scheduling grant (Pm-dsg) shall be below the specified value in Table 8.8.4.2-2. The purpose of this test is to verify the localized EPDCCH performance, when the EPDCCH transmission in the serving cell is interfered by the CRS of the interfering cells, applying the CRS interference model defined in clause B.6.5. In Table 8.8.4.1-1, Cell 1 is the serving cell, and Cell 2 and Cell 3 are the aggressor cells. The downlink physical setup is in accordance with Annex C.3.2 for each of Cell 1, Cell 2 and Cell 3, respectively. The CRS assistance information [7] is provided and includes Cell 2 and Cell 3.

Table 8.8.4.2-1: Test Parameters for EPDCCH

Parameter		Unit	Cell 1	Cell 2	Cell 3
Number of PDCCH symbols		symbols	1 (Note 1)	2	2
EPDCCH starting symbol		symbols	2 (Note 1)	N/A	N/A
PHICH duration			Normal	Normal	Normal
Unused RE-s and PRB-s			OCNG	N/A	N/A
Cell ID			0	1	6
Downlink power allocation	$\rho_A$	dB	0	-3	-3
	$\rho_B$	dB	0	-3	-3
	$\sigma$	dB	-3	0	0
	$\delta$	dB	0	0	0
Cell-specific reference signals			Antenna ports 0,1	Antenna ports 0,1	Antenna ports 0,1
$N_{oc}$ at antenna port		dBm/15kHz	-98		
$\bar{E}_s/N_{oc}$		dB	N/A	13.91	3.34
$BW_{channel}$		MHz	10	10	10
Cyclic Prefix			Normal	Normal	Normal
Subframe Configuration			Non-MBSFN	Non-MBSFN	Non-MBSFN
EPDCCH Precoder Update Granularity	PRB		1	N/A	N/A
	ms		1	N/A	N/A
EPDCCH Beamforming Pre-Coder			Annex B. 4.5	N/A	N/A
CSI-RS Reference Signal			Port 15 and 16	N/A	N/A
CSI-RS reference signal resource configuration			0	N/A	N/A
CSI reference signal subframe configuration $l_{CSI-RS}$			2	N/A	N/A
ZP-CSI-RS configuration bitmap			000001000000 0000	N/A	N/A
ZP-CSI-RS subframe configuration $l_{ZP-CSI-RS}$			2	N/A	N/A
Number of EPDCCH Sets			1	N/A	N/A
EPDCCH Set type			Localized	N/A	N/A
Number of PRB per EPDCCH Set			8	N/A	N/A
EPDCCH Set PRBs			0, 7, 14, 21, 28, 35, 42, 49	N/A	N/A
PDSCH TM			TM9	N/A	N/A
Interference model			N/A	As specified in clause B.6.5	As specified in clause B.6.5
Time offset to cell 1		$\mu$ s	N/A	2	3
Frequency offset to cell 1		Hz	N/A	200	300
TDD UL/DL Configuration			0	0	0
TDD Special Subframe			1 (Note 4)	1	1
Note 1: The starting symbol for EPDCCH is signalled with <i>epdcch-StartSymbol-r11</i> . CFI is set to 1.					
Note 2: EPDCCH is scheduled in every subframe. EPDCCH Subframe Monitoring pattern is not configured.					
Note 3: Demodulation performance is averaged over normal and special subframes.					

Table 8.8.4.2-2: Minimum performance for EPDCCH for enhanced downlink control channel performance requirements Type A

Test number	Bandwidth	Aggregation level	Reference Channel	OCNG Pattern	Propagation Condition	Antenna configuration and correlation Matrix	Reference value	
							Pm-dsg (%)	SNR (dB)
1	10 MHz	2 ECCE	R.57 TDD	OP.7 TDD	EPA5	2 x 2 Low	1	14.2

## 8.8.5 Enhanced Downlink Control Channel Performance Requirements Type A - Distributed Transmission with TM9 Interference Model

### 8.8.5.1 TDD

For the parameters specified in Table 8.8.5.1-1 the average probability of a missed downlink scheduling grant ( $P_{m-dsg}$ ) shall be below the specified value in Table 8.8.5.1-2. The purpose of this test is to verify the distributed EPDCCH performance when the EPDCCH transmission in the serving cell is interfered by two interfering cells and applying TM9 interference model. In Table 8.8.5.1-1, Cell 1 is the serving cell, and Cell 2 and Cell 3 are the aggressor cells. The downlink physical setup is in accordance with Annex C.3.2 for each of Cell 1, Cell 2 and Cell 3, respectively. The CRS assistance information [7] is provided and includes Cell 2 and Cell 3.

**Table 8.8.5.1-1: Test Parameters for EPDCCH**

Parameter		Unit	Cell 1	Cell 2	Cell 3
Number of PDCCH symbols		symbols	2 (Note 1)	2	2
PHICH duration			Normal	Normal	Normal
Cell ID			0	6	1
Downlink power allocation	$\rho_A$	dB	-3	-3	-3
	$\rho_B$	dB	-3	-3	-3
	$\sigma$	dB	0	0	0
	$\delta$	dB	3	3	3
Cell-specific reference signals			Antenna ports 0,1	Antenna ports 0,1	Antenna ports 0,1
$N_{oc}$ at antenna port		dBm/15kHz	-98		
$\bar{E}_c/N_{oc}$		dB	N/A	13.91	3.34
BW <sub>Channel</sub>		MHz	10	10	10
Cyclic Prefix			Normal	Normal	Normal
Subframe Configuration			Non-MBSFN	Non-MBSFN	Non-MBSFN
EPDCCH precoder Update Granularity	PRB		1	N/A	N/A
	ms		1	N/A	N/A
Beamforming Pre-Coder			Annex B. 4.4	N/A	N/A
Number of EPDCCH Sets Configured			1	N/A	N/A
EPDCCH Set type			Distributed	N/A	N/A
Number of PRB per EPDCCH Set			4	N/A	N/A
EPDCCH Set PRBs			3, 17, 31, 45	N/A	N/A
PDSCH TM			TM9	N/A	N/A
Interference model			N/A	As specified in clause B.5.4	As specified in clause B.5.4
Probability of occurrence of PDSCH transmission rank in interfering cells	Rank 1	%	N/A	70	70
	Rank 2	%	N/A	30	30
PDSCH precoder update granularity		PRB	N/A	50	50
Time offset to cell 1		$\mu$ s	N/A	2	3
Frequency offset to cell 1		Hz	N/A	200	300
TDD UL/DL Configuration			0	0	0
TDD Special Subframe			1 (Note 3)	1	1
Note 1: The starting symbol for EPDCCH is derived from the PCFICH. RRC signalling <i>epdcch-StartSymbol-r11</i> is not configured.					
Note 2: EPDCCH is scheduled in every subframe. EPDCCH Subframe Monitoring pattern is not configured.					
Note 3: Demodulation performance is averaged over normal and special subframes.					



**Table 8.8.5.1-2: Minimum performance for EPDCCH for enhanced downlink control channel performance requirements Type A**

Test number	Bandwidth	Aggregation level	Reference Channel	OCNG Pattern	Propagation Condition	Antenna configuration and correlation Matrix	Reference value	
							Pm-dsg (%)	SNR (dB)
1	10 MHz	4 ECCE	R.55-1 TDD	OP.7 TDD	EPA5	2 x 2 Low	1	14.8

## 8.8.6 Enhanced Downlink Control Channel Performance Requirements Type A - Distributed Transmission with TM3 Interference Model

### 8.8.6.1 FDD

For the parameters specified in Table 8.8.6.1-1 the average probability of a missed downlink scheduling grant (Pm-dsg) shall be below the specified value in Table 8.8.6.1-2. The purpose of this test is to verify the distributed EPDCCH performance when the serving cell EPDCCH transmission is interfered by two interfering cells applying asynchronous TM3 interference model. In Table 8.8.6.1-1, Cell 1 is the serving cell, and Cell 2 and Cell 3 are the aggressor cells. The downlink physical setup is in accordance with Annex C.3.2 for each of Cell 1, Cell 2 and Cell 3, respectively. The CRS assistance information [7] is not provided.

**Table 8.8.6.1-1: Test Parameters for EPDCCH**

Parameter		Unit	Cell 1	Cell 2	Cell 3
Number of PDCCH symbols		symbols	2 (Note 1)	2	2
PHICH duration			Normal	Normal	Normal
Cell ID			0	1	6
Downlink power allocation	$\rho_A$	dB	-3	-3	-3
	$\rho_B$	dB	-3	-3	-3
	$\sigma$	dB	0	0	0
	$\delta$	dB	3	0	0
Cell-specific reference signals			Antenna ports 0,1	Antenna ports 0,1	Antenna ports 0,1
$N_{oc}$ at antenna port		dBm/15kHz		-98	
$\bar{E}_s/N_{oc}$		dB	N/A	13.91	3.34
$BW_{channel}$		MHz	10	10	10
Cyclic Prefix			Normal	Normal	Normal
Subframe Configuration			Non-MBSFN	Non-MBSFN	Non-MBSFN
EPDCCH Precoder Update Granularity	PRB		1	N/A	N/A
	ms		1	N/A	N/A
EPDCCH Beamforming Pre-Coder			Annex B.4.4	N/A	N/A
Number of EPDCCH Sets Configured			1	N/A	N/A
EPDCCH Set type			Distributed	N/A	N/A
Number of PRB per EPDCCH Set			4	N/A	N/A
EPDCCH Set PRBs			3, 17, 31, 45	N/A	N/A
PDSCH TM			TM9	N/A	N/A
Interference model			N/A	As specified in clause B.5.2	As specified in clause B.5.2
Probability of occurrence of PDSCH transmission rank in interfering cells	Rank 1	%	N/A	70	70
	Rank 2	%	N/A	30	30
Time offset to cell 1		$\mu$ s	N/A	330	667
Frequency offset to cell 1		Hz	N/A	0	0
Note 1: The starting symbol for EPDCCH is derived from the PCFICH. RRC signalling <i>epdcch-StartSymbol-r11</i> is not configured.					
Note 2: EPDCCH is scheduled in every subframe. EPDCCH Subframe Monitoring pattern is not configured.					

**Table 8.8.6.1-2: Minimum performance for EPDCCH for enhanced downlink control channel performance requirements Type A**

Test number	Bandwidth	Aggregation level	Reference Channel	OCNG Pattern	Propagation Condition	Antenna configuration and correlation Matrix	Reference value	
							Pm-dsg (%)	SNR (dB)
1	10 MHz	4 ECCE	R.55-1 FDD	OP.7 FDD	EVA70	2 x 2 Low	1	15.9

## 8.9 Demodulation (single receiver antenna)

The SNR definition is given in Clause 8.1.1 where the number of receiver antennas  $N_{RX}$  assumed for the minimum performance requirement in this clause is 1.

### 8.9.1 PDSCH

#### 8.9.1.1 FDD and half-duplex FDD (Fixed Reference Channel)

The parameters specified in Table 8.9.1.1-1 are valid for FDD and half-duplex FDD tests unless otherwise stated.

**Table 8.9.1.1-1: Common Test Parameters (FDD and half-duplex FDD)**

Parameter	Unit	Value
Inter-TTI Distance		1
Number of HARQ processes per component carrier	Processes	8
Maximum number of HARQ transmission		4
Redundancy version coding sequence		{0,1,2,3} for QPSK and 16QAM {0,0,1,2} for 64QAM
Number of OFDM symbols for PDCCH per component carrier	OFDM symbols	4 for 1.4 MHz bandwidth, 3 for 3 MHz and 5 MHz bandwidths, 2 for 10 MHz, 15 MHz and 20 MHz bandwidths
Cyclic Prefix		Normal
Precoder update granularity		Frequency domain: 1 PRG Time domain: 1 ms for Transmission mode 9

#### 8.9.1.1.1 Transmit diversity performance (Cell-Specific Reference Symbols)

##### 8.9.1.1.1.1 Minimum Requirement 2 Tx Antenna Port

The requirements are specified in Table 8.9.1.1.1-2, with the addition of the parameters in Table 8.9.1.1.1-1 and the downlink physical channel setup according to Annex C.3.2. The purpose is to verify the performance of transmit diversity (SFBC) with 2 transmitter antennas.

**Table 8.9.1.1.1.1-1: Test Parameters for Transmit diversity Performance (FRC)**

Parameter		Unit	Test 1-2
Downlink power allocation	$\rho_A$	dB	-3
	$\rho_B$	dB	-3 (Note 1)
	$\sigma$	dB	0
$N_{oc}$ at antenna port		dBm/15kHz	-98
PDSCH transmission mode			2
Note 1: $\rho_B = 1$ .			

**Table 8.9.1.1.1.1-2: Minimum performance Transmit Diversity (FRC)**

Test number	Bandwidth and MCS	Reference Channel	OCNG Pattern	Propagation Condition	Correlation Matrix and Antenna Configuration	Reference value		UE DL category
						Fraction of Maximum Throughput (%)	SNR (dB)	
1	10 MHz 16QAM 1/2	R.62 FDD	OP.1 FDD	EPA5	2x1 Low	70	9.0	0
2	10 MHz 16QAM 1/2	R.84 FDD	OP.1 FDD	EPA5	2x1 Low	70	9.3	1bis

### 8.9.1.1.2 Closed-loop spatial multiplexing performance (Cell-Specific Reference Symbols)

#### 8.9.1.1.2.1 Minimum Requirement Single-Layer Spatial Multiplexing 2 Tx Antenna Port

The requirements are specified in Table 8.9.1.1.2.1-2, with the addition of the parameters in Table 8.9.1.1.2.1-1 and the downlink physical channel setup according to Annex C.3.2. The purpose of these tests is to verify the closed loop rank-one performance with frequency selective precoding.

**Table 8.9.1.1.2.1-1: Test Parameters for Single-Layer Spatial Multiplexing (FRC)**

Parameter	Unit	Test 1
Downlink power allocation	$\rho_A$	dB
	$\rho_B$	dB
	$\sigma$	dB
$N_{oc}$ at antenna port	dBm/15kHz	-98
Precoding granularity	PRB	6
PMI delay (Note 2)	ms	8
Reporting interval	ms	8
Reporting mode		PUSCH 1-2
CodeBookSubsetRestriction bitmap		001111
PDSCH transmission mode		4
Note 1: $\rho_B = 1$ .		
Note 2: If the UE reports in an available uplink reporting instance at subframe SF#n based on PMI estimation at a downlink SF not later than SF#(n-4), this reported PMI cannot be applied at the eNB downlink before SF#(n+4).		

**Table 8.9.1.1.2.1-2: Minimum performance Single-Layer Spatial Multiplexing (FRC)**

Test number	Bandwidth and MCS	Reference Channel	OCNG Pattern	Propagation Condition	Correlation Matrix and Antenna Configuration	Reference value		UE DL category
						Fraction of Maximum Throughput (%)	SNR (dB)	
1	10 MHz 64QAM 1/2	R.63 FDD	OP.1 FDD	EPA5	2x1 Low	70	13.2	0

**8.9.1.1.2.2 Minimum Requirement Single-Layer Spatial Multiplexing 4 Tx Antenna Port**

The requirements are specified in Table 8.9.1.1.2.2-2, with the addition of the parameters in Table 8.9.1.1.2.2-1 and the downlink physical channel setup according to Annex C.3.2. The purpose of these tests is to verify the closed loop rank-one performance with frequency selective precoding.

**Table 8.9.1.1.2.2-1: Test Parameters for Single-Layer Spatial Multiplexing (FRC)**

Parameter	Unit	Test 1
Downlink power allocation	$\rho_A$	-6
	$\rho_B$	-6 (Note 1)
	$\sigma$	0
$N_{oc}$ at antenna port	dBm/15kHz	-98
Precoding granularity	PRB	6
PMI delay (Note 2)	ms	8
Reporting interval	ms	8
Reporting mode		PUSCH 1-2
CodeBookSubsetRestriction bitmap		000000000000FFFF
PDSCH transmission mode		4
Note 1: $P_B = 1$ .		
Note 2: If the UE reports in an available uplink reporting instance at subframe SF#n based on PMI estimation at a downlink SF not later than SF#(n-4), this reported PMI cannot be applied at the eNB downlink before SF#(n+4).		

**Table 8.9.1.1.2.2-2: Minimum performance Single-Layer Spatial Multiplexing (FRC)**

Test number	Bandwidth and MCS	Reference Channel	OCNG Pattern	Propagation Condition	Correlation Matrix and Antenna Configuration	Reference value		UE DL category
						Fraction of Maximum Throughput (%)	SNR (dB)	
1	10 MHz 64QAM 1/2	R.85 FDD	OP.1 FDD	EPA5	4x1 Low	70	11.3	1bis

**8.9.1.1.2.3 Minimum Requirement Single-Layer Spatial Multiplexing 4 Tx Antenna Ports with CRS assistance information**

The requirements are specified in Table 8.9.1.1.2.3-2, with the addition of parameters in Table 8.9.1.1.2.3-1. In Table 8.9.1.1.2.3-1, Cell 1 is the serving cell, and Cell 2 and Cell 3 are the aggressor cells. The downlink physical channel setup is according to Annex C.3.2 for each of Cell 1, Cell 2 and Cell 3, respectively. The CRS assistance information [7] is provided to the UE and includes information on Cell 2 and Cell 3.

The purpose of the test is to verify the closed loop single layer TM4 performance under assumption that UE applies CRS interference mitigation in the scenario with 4 CRS antenna ports in the serving and aggressor cells.

Table 8.9.1.1.2.3-1: Test Parameters

Parameter		Unit	Cell 1	Cell 2	Cell 3
Downlink power allocation	$\rho_A$	dB	-6	-6	-6
	$\rho_B$	dB	-6 (Note 1)	-6 (Note 1)	-6 (Note 1)
	$\sigma$	dB	3	3	3
$N_{oc}$ at antenna port		dBm/15kHz	-98	N/A	N/A
$\bar{E}_s/N_{oc}$		dB	N/A	10.45	4.6
BW <sub>channel</sub>		MHz	10	10	10
Cyclic prefix			Normal	Normal	Normal
Subframe Configuration			Non-MBSFN	Non-MBSFN	Non-MBSFN
Cell ID			0	1	6
Cell-specific reference signals			Antenna ports 0,1,2,3		
Number of control OFDM symbols (CFI)			2	2	2
PDSCH transmission mode			4	N/A	N/A
Precoding granularity		PRB	50	N/A	N/A
PMI delay (Note 2)		ms	8	N/A	N/A
Reporting interval		ms	1	N/A	N/A
Reporting mode			PUSCH 3-1	N/A	N/A
CodeBookSubsetRestriction bitmap			000000000000 FFFF	N/A	N/A
Time offset relative to Cell 1		$\mu$ s	N/A	3	-1
Frequency shift relative to Cell 1		Hz	N/A	300	-100
Interference model			N/A	As specified in clause B.5.3	As specified in clause B.5.3
Probability of occurrence of transmission in interference cells		%	N/A	20	20
Probability of occurrence of transmission rank in interfering cells	Rank 1	%	N/A	80	80
	Rank 2	%	N/A	20	20
Note 1: $P_B = 1$ .					
Note 2: If the UE reports in an available uplink reporting instance at subframe SF #n based on PMI estimation at a downlink SF not later than SF #(n-4), this reported PMI cannot be applied at the eNB downlink before SF #(n+4).					
Note 3: SIB-1 will not be transmitted in Cell 2 and Cell 3 in this test.					

Table 8.9.1.1.2.3-2: Minimum performance for PDSCH

Test Number	Reference Channel	OCNG Pattern			Propagation Conditions (Note1)			Correlation Matrix and Antenna Configuration (Note 2)	Reference Value		UE Category
		Cell 1	Cell 2	Cell 3	Cell 1	Cell 2	Cell 3		Fraction of Maximum Throughput (%)	SNR (dB) (Note 3)	
1	R.93 FDD	OP.1 FDD	N/A	N/A	EPA5			4x1 Low	70	16.7	1bis
Note 1: The propagation conditions for Cell 1, Cell 2 and Cell 3 are statistically independent.											
Note 2: The correlation matrix and antenna configuration apply for Cell 1, Cell 2 and Cell 3.											
Note 3: SNR corresponds to $\bar{E}_s/N_{oc}$ of cell 1.											

### 8.9.1.1.3 Closed-loop spatial multiplexing performance (User-Specific Reference Symbols)

#### 8.9.1.1.3.1 Single-layer Spatial Multiplexing

For single-layer transmission on antenna ports 7 or 8 upon detection of a PDCCH with DCI format 2C, the requirements are specified in Table 8.9.1.1.3.1-2 with the addition of the parameters in Table 8.9.1.1.3.1-1 and the downlink physical channel setup according to Annex C.3.2. The purpose of these tests is to verify rank-1 performance on one of the

antenna ports 7 or 8, and to verify rate matching with multiple CSI reference symbol configurations with non-zero and zero transmission power.

**Table 8.9.1.1.3.1-1: Test Parameters for Testing CDM-multiplexed DM RS (single layer) with multiple CSI-RS configurations**

parameter		Unit	Test 1	Test 2
Downlink power allocation	$\rho_A$	dB	0	
	$\rho_B$	dB	0 (Note 1)	
	$\sigma$	dB	-3	
Beamforming model			Annex B.4.1	Annex B.4.3
Cell-specific reference signals			Antenna ports 0,1	Antenna ports 0,1
CSI reference signals			Antenna ports 15,...,18	Antenna ports 15,16
CSI-RS periodicity and subframe offset $T_{\text{CSI-RS}} / \Delta_{\text{CSI-RS}}$		Subframes	5 / 2	5 / 2
CSI reference signal configuration			0	0
Zero-power CSI-RS configuration $l_{\text{CSI-RS}} / \text{ZeroPowerCSI-RS bitmap}$		Subframes / bitmap	3 / 0001000000000000	3 / 0001000000000000
$N_{oc}$ at antenna port		dBm/15kHz	-98	-98
Symbols for unused PRBs			OCNG (Note 4)	OCNG (Note 3)
Reporting mode			N/A	PUSCH 3-1
Reporting interval			N/A	5
PMI delay (Note 4)			N/A	8
CodeBookSubsetRestriction bitmap			N/A	001111
Number of allocated resource blocks (Note 2)		PRB	6	50
PDSCH transmission mode			9	
Note 1: $P_B = 1$ .				
Note 2: The modulation symbols of the signal under test are mapped onto antenna port 7 or 8.				
Note 3: These physical resource blocks are assigned to an arbitrary number of virtual UEs with one PDSCH per virtual UE; the data transmitted over the OCNG PDSCHs shall be uncorrelated pseudo random data, which is QPSK modulated.				
Note 4: If the UE reports in an available uplink reporting instance at subframe SF#n based on PMI estimation at a downlink SF not later than SF#(n-4), this reported PMI cannot be applied at the eNB downlink before SF#(n+4).				

**Table 8.9.1.1.3.1-2: Minimum performance for CDM-multiplexed DM RS (FRC) with multiple CSI-RS configurations**

Test number	Bandwidth and MCS	Reference Channel	OCNG Pattern	Propagation Condition	Correlation Matrix and Antenna Configuration	Reference value		UE DL category
						Fraction of Maximum Throughput (%)	SNR (dB)	
1	10 MHz QPSK 1/3	R.64 FDD	OP.1 FDD	EPA5	2x1 Low	70	4.7	0
2	10 MHz QPSK 1/3	R.86 FDD	OP.1 FDD	EPA5	2x1 Low	70	2.5	1bis

## 8.9.1.1.3.2 Single-layer Spatial Multiplexing with CRS assistance information

The requirements are specified in Table 8.9.1.1.3.2-2, with the addition of parameters in Table 8.9.1.1.3.2-1. In Table 8.9.1.1.3.2-1, Cell 1 is the serving cell, and Cell 2 and Cell 3 are the aggressor cells. The downlink physical channel setup is according to Annex C.3.2 for each of Cell 1, Cell 2 and Cell 3, respectively. The CRS assistance information [7] is provided to the UE and includes information on Cell 2 and Cell 3.

The purpose of the test is to verify the single-layer spatial multiplexing TM9 performance under assumption that UE applies CRS interference mitigation in the scenario with 2 CRS antenna ports in the serving and aggressor cells.

Table 8.9.1.1.3.2-1: Test Parameters

Parameter		Unit	Cell 1	Cell 2	Cell 3
Downlink power allocation	$\rho_A$	dB	0	0	0
	$\rho_B$	dB	0 (Note 1)	0 (Note 1)	0 (Note 1)
	$\sigma$	dB	-3	-3	-3
$N_{oc}$ at antenna port		dBm/15kHz	-98	N/A	N/A
	$\bar{E}_s/N_{oc}$	dB	N/A	11.75	5.69
	$BW_{channel}$	MHz	10	10	10
	Cyclic prefix		Normal	Normal	Normal
	Subframe Configuration		Non-MBSFN	Non-MBSFN	Non-MBSFN
	Cell ID		0	1	6
Cell-specific reference signals			Antenna ports 0,1		
	Number of control OFDM symbols (CFI)		2	2	2
	CSI reference signals		Antenna ports 15,16	N/A	N/A
	CSI-RS periodicity and subframe offset $T_{CSI-RS} / \Delta_{CSI-RS}$	Subframes	5 / 2	N/A	N/A
	CSI reference signal configuration		8	N/A	N/A
	Zero-power CSI-RS configuration $I_{CSI-RS} / ZeroPowerCSI-RS$ bitmap	Subframes / bitmap	3 / 001000000000000	N/A	N/A
	PDSCH transmission mode		TM9	N/A	N/A
	Precoding granularity		Frequency domain: 1 PRG Time domain: 1 ms	N/A	N/A
	Beamforming model		Annex B.4.1	N/A	N/A
	CodeBookSubsetRestriction bitmap		001111	N/A	N/A
	Time offset relative to Cell 1	$\mu s$	N/A	3	-1
	Frequency shift relative to Cell 1	Hz	N/A	300	-100
	Interference model		N/A	As specified in clause B.5.4	As specified in clause B.5.4
	Probability of occurrence of transmission in interference cells	%	N/A	10	10
Probability of occurrence of transmission rank in interfering cells	Rank 1	%	N/A	80	80
	Rank 2	%	N/A	20	20
Note 1: $P_B = 1$ .					
Note 2: If the UE reports in an available uplink reporting instance at subframe SF #n based on PMI estimation at a downlink SF not later than SF#(n-4), this reported PMI cannot be applied at the eNB downlink before SF#(n+4).					
Note 3: SIB-1 will not be transmitted in Cell 2 and Cell 3 in this test.					

Table 8.9.1.1.3.2-2: Minimum Performance

Test Number	Reference Channel	OCNG Pattern			Propagation Conditions (Note1)			Correlation Matrix and Antenna Configuration (Note 2)	Reference Value		UE Category
		Cell 1	Cell 2	Cell 3	Cell 1	Cell 2	Cell 3		Fraction of Maximum Throughput (%)	SNR (dB) (Note 3)	
1	R.94 FDD	OP.1 FDD	N/A	N/A	EPA5			2x1 Low	70	11.9	1bis

Note 1: The propagation conditions for Cell 1, Cell 2 and Cell 3 are statistically independent.  
Note 2: The correlation matrix and antenna configuration apply for Cell 1, Cell 2 and Cell 3.  
Note 3: SNR corresponds to  $\bar{E}_s/N_{oc}$  of cell 1.

## 8.9.1.2 TDD (Fixed Reference Channel)

The parameters specified in Table 8.9.1.2-1 are valid for all TDD tests unless otherwise stated.

Table 8.9.1.2-1: Common Test Parameters (TDD)

Parameter	Unit	Value
Uplink downlink configuration (Note 1)		1
Special subframe configuration (Note 2)		4
Cyclic prefix		Normal
Cell ID		0
Inter-TTI Distance		1
Number of HARQ processes per component carrier	Processes	7
Maximum number of HARQ transmission		4
Redundancy version coding sequence		{0,1,2,3} for QPSK and 16QAM {0,0,1,2} for 64QAM
Number of OFDM symbols for PDCCH per component carrier	OFDM symbols	4 for 1.4 MHz bandwidth, 3 for 3 MHz and 5 MHz bandwidths, 2 for 10 MHz, 15 MHz and 20 MHz bandwidths
Precoder update granularity		Frequency domain: 1 PRG Time domain: 1 ms for Transmission mode 9
ACK/NACK feedback mode		Multiplexing

Note 1: as specified in Table 4.2-2 in TS 36.211 [4].

Note 2: as specified in Table 4.2-1 in TS 36.211 [4].

## 8.9.1.2.1 Transmit diversity performance (Cell-Specific Reference Symbols)

## 8.9.1.2.1.1 Minimum Requirement 2 Tx Antenna Port

The requirements are specified in Table 8.9.1.2.1.1-2, with the addition of the parameters in Table 8.9.1.2.1.1-1 and the downlink physical channel setup according to Annex C.3.2. The purpose is to verify the performance of transmit diversity (SFBC) with 2 transmitter antennas.



**Table 8.9.1.2.1.1-1: Test Parameters for Transmit diversity Performance (FRC)**

Parameter	Unit	Test 1-2
Downlink power allocation	$\rho_A$	dB
	$\rho_B$	dB
	$\sigma$	dB
$N_{oc}$ at antenna port	dBm/15kHz	-98
PDSCH transmission mode		2
Note 1: $P_B = 1$ .		

**Table 8.9.1.2.1.1-2: Minimum performance Transmit Diversity (FRC)**

Test number	Bandwidth	Reference Channel	OCNG Pattern	Propagation Condition	Correlation Matrix and Antenna Configuration	Reference value		UE DL category
						Fraction of Maximum Throughput (%)	SNR (dB)	
1	10 MHz 16QAM 1/2	R.62 TDD	OP.1 TDD	EPA5	2x1 Low	70	8.8	0
2	10 MHz 16QAM 1/2	R.84 TDD	OP.1 TDD	EPA5	2x1 Low	70	9.5	1bis

### 8.9.1.2.2 Closed-loop spatial multiplexing performance (Cell-Specific Reference Symbols)

#### 8.9.1.2.2.1 Minimum Requirement Single-Layer Spatial Multiplexing 2 Tx Antenna Port

The requirements are specified in Table 8.9.1.2.2.1-2, with the addition of the parameters in Table 8.9.1.2.2.1-1 and the downlink physical channel setup according to Annex C.3.2. The purpose of these tests is to verify the closed loop rank-one performance with frequency selective precoding.

**Table 8.9.1.2.2.1-1: Test Parameters for Single-Layer Spatial Multiplexing (FRC)**

Parameter	Unit	Test 1
Downlink power allocation	$\rho_A$	dB
	$\rho_B$	dB
	$\sigma$	dB
$N_{oc}$ at antenna port	dBm/15kHz	-98
Precoding granularity	PRB	6
PMI delay (Note 2)	ms	10 or 11
Reporting interval	ms	1 or 4 (Note 3)
Reporting mode		PUSCH 1-2
CodeBookSubsetRestriction bitmap		001111
ACK/NACK feedback mode		Multiplexing
PDSCH transmission mode		4
Note 1: $P_B = 1$ .		
Note 2: If the UE reports in an available uplink reporting instance at subframe SF#n based on PMI estimation at a downlink SF not later than SF#(n-4), this reported PMI cannot be applied at the eNB downlink before SF#(n+4).		
Note 3: For Uplink - downlink configuration 1 the reporting interval will alternate between 1ms and 4ms.		

Table 8.9.1.2.2.1-2: Minimum performance Single-Layer Spatial Multiplexing (FRC)

Test number	Bandwidth	Reference Channel	OCNG Pattern	Propagation Condition	Correlation Matrix and Antenna Configuration	Reference value		UE DL category
						Fraction of Maximum Throughput (%)	SNR (dB)	
1	10 MHz 64QAM 1/2	R.63 TDD	OP.1 TDD	EPA5	2x1 Low	70	13.1	0

## 8.9.1.2.2.2 Minimum Requirement Single-Layer Spatial Multiplexing 4 Tx Antenna Port

The requirements are specified in Table 8.9.1.2.2.2-2, with the addition of the parameters in Table 8.9.1.2.2.2-1 and the downlink physical channel setup according to Annex C.3.2. The purpose of these tests is to verify the closed loop rank-one performance with frequency selective precoding.

Table 8.9.1.2.2.2-1: Test Parameters for Single-Layer Spatial Multiplexing (FRC)

Parameter	Unit	Test 1
Downlink power allocation	$\rho_A$	-6
	$\rho_B$	-6 (Note 1)
	$\sigma$	0
$N_{oc}$ at antenna port	dBm/15kHz	-98
Precoding granularity	PRB	6
PMI delay (Note 2)	ms	10 or 11
Reporting interval	ms	1 or 4 (Note 3)
Reporting mode		PUSCH 1-2
CodeBookSubsetRestriction bitmap		000000000000FFFF
ACK/NACK feedback mode		Multiplexing
PDSCH transmission mode		4
Note 1: $P_B = 1$ .		
Note 2: If the UE reports in an available uplink reporting instance at subframe SF#n based on PMI estimation at a downlink SF not later than SF#(n-4), this reported PMI cannot be applied at the eNB downlink before SF#(n+4).		
Note 3: For Uplink - downlink configuration 1 the reporting interval will alternate between 1ms and 4ms.		

Table 8.9.1.2.2.2-2: Minimum performance Single-Layer Spatial Multiplexing (FRC)

Test number	Bandwidth	Reference Channel	OCNG Pattern	Propagation Condition	Correlation Matrix and Antenna Configuration	Reference value		UE DL category
						Fraction of Maximum Throughput (%)	SNR (dB)	
1	10 MHz 64QAM 1/2	R.85 TDD	OP.1 TDD	EPA5	4x1 Low	70	11.6	1bis

## 8.9.1.2.2.3 Minimum Requirement Single-Layer Spatial Multiplexing 4 Tx Antenna Ports with CRS assistance information

The requirements are specified in Table 8.9.1.2.2.3-2, with the addition of parameters in Table 8.9.1.2.2.3-1. In Table 8.9.1.2.2.3-1, Cell 1 is the serving cell, and Cell 2 and Cell 3 are the aggressor cells. The downlink physical channel setup is according to Annex C.3.2 for each of Cell 1, Cell 2 and Cell 3, respectively. The CRS assistance information [7] is provided to the UE and includes information on Cell 2 and Cell 3.

The purpose of the test is to verify the closed loop single layer TM4 performance under assumption that UE applies CRS interference mitigation in the scenario with 4 CRS antenna ports in the serving and aggressor cells.

Table 8.9.1.2.2.3-1: Test Parameters

Parameter	Unit	Cell 1	Cell 2	Cell 3	
Uplink downlink Configuration		1	1	1	
Special subframe configuration		4	4	4	
Downlink power allocation	$\rho_A$	dB	-6	-6	-6
	$\rho_B$	dB	-6 (Note 1)	-6 (Note 1)	-6 (Note 1)
	$\sigma$	dB	3	3	3
$N_{oc}$ at antenna port	dBm/15kHz	-98	N/A	N/A	
$\bar{E}_s/N_{oc}$	dB	N/A	10.45	4.6	
$BW_{channel}$	MHz	10	10	10	
Cyclic prefix		Normal	Normal	Normal	
Subframe Configuration		Non-MBSFN	Non-MBSFN	Non-MBSFN	
Cell ID		0	1	6	
Cell-specific reference signals		Antenna ports 0,1,2,3			
Number of control OFDM symbols (CFI)		2	2	2	
PDSCH transmission mode		4	N/A	N/A	
Precoding granularity	PRB	50	N/A	N/A	
PMI delay (Note 2)	ms	8	N/A	N/A	
Reporting interval	ms	1 or 4 (Note 4)	N/A	N/A	
Reporting mode		PUSCH 3-1	N/A	N/A	
CodeBookSubsetRestriction bitmap		000000000000 FFFF	N/A	N/A	
Time offset relative to Cell 1	$\mu$ s	N/A	3	-1	
Frequency shift relative to Cell 1	Hz	N/A	300	-100	
Interference model		N/A	As specified in clause B.5.3	As specified in clause B.5.3	
Probability of occurrence of transmission in interference cells	%	N/A	20	20	
Probability of occurrence of transmission rank in interfering cells	Rank 1	%	N/A	80	80
	Rank 2	%	N/A	20	20
Note 1: $P_B = 1$ .					
Note 2: If the UE reports in an available uplink reporting instance at subframe SF #n based on PMI estimation at a downlink SF not later than SF #(n-4), this reported PMI cannot be applied at the eNB downlink before SF#(n+4).					
Note 3: SIB-1 will not be transmitted in Cell 2 and Cell 3 in this test.					
Note 4: For Uplink - downlink configuration 1 the reporting interval will alternate between 1ms and 4ms.					

Table 8.9.1.2.2.3-2: Minimum performance for PDSCH

Test Number	Reference Channel	OCNG Pattern			Propagation Conditions (Note1)			Correlation Matrix and Antenna Configuration (Note 2)	Reference Value		UE Category
		Cell 1	Cell 2	Cell 3	Cell 1	Cell 2	Cell 3		Fraction of Maximum Throughput (%)	SNR (dB) (Note 3)	
1	R.93 TDD	OP.1 TDD	N/A	N/A	EPA5			4x1 Low	70	16.8	1bis
Note 1: The propagation conditions for Cell 1, Cell 2 and Cell 3 are statistically independent.											
Note 2: The correlation matrix and antenna configuration apply for Cell 1, Cell 2 and Cell 3.											
Note 3: SNR corresponds to $\bar{E}_s/N_{oc}$ of cell 1.											

## 8.9.1.2.3 Closed-loop spatial multiplexing performance (User-Specific Reference Symbols)

## 8.9.1.2.3.1 Single-layer Spatial Multiplexing

For single-layer transmission on antenna ports 7 or 8 upon detection of a PDCCH with DCI format 2C, the requirements are specified in Table 8.9.1.2.3.1-2 with the addition of the parameters in Table 8.9.1.2.3.1-1 and the downlink physical channel setup according to Annex C.3.2. The purpose of these tests is to verify rank-1 performance on one of the antenna ports 7 or 8, and to verify rate matching with multiple CSI reference symbol configurations with non-zero and zero transmission power.

**Table 8.9.1.2.3.1-1: Test Parameters for Testing CDM-multiplexed DM RS (single layer) with multiple CSI-RS configurations**

Parameter	Unit	Test 1	Test 2
Downlink power allocation	$\rho_A$	dB	0
	$\rho_B$	dB	0 (Note 1)
	$\sigma$	dB	-3
Cell-specific reference signals		Antenna ports 0,1	Antenna ports 0,1
CSI reference signals		Antenna ports 15,...,18	Antenna ports 15,16
Beamforming model		Annex B.4.1	Annex B.4.3
CSI-RS periodicity and subframe offset $T_{\text{CSI-RS}} / \Delta_{\text{CSI-RS}}$	Subframes	5 / 4	5 / 4
CSI reference signal configuration		1	1
Zero-power CSI-RS configuration $I_{\text{CSI-RS}} / \text{ZeroPowerCSI-RS bitmap}$	Subframes / bitmap	4 / 0010000100000000	4 / 0000001000000000
$N_{oc}$ at antenna port	dBm/15kHz	-98	-98
Symbols for unused PRBs		OCNG (Note 4)	OCNG (Note 3)
Reporting mode		N/A	PUSCH 3-1
Reporting interval		N/A	5
PMI delay (Note 4)		N/A	10
CodeBookSubsetRestriction bitmap		N/A	001111
Number of allocated resource blocks (Note 2)	PRB	6	
Simultaneous transmission		No	
PDSCH transmission mode		9	
Note 1: $P_B = 1$ . Note 2: The modulation symbols of the signal under test are mapped onto antenna port 7 or 8. Note 3: These physical resource blocks are assigned to an arbitrary number of virtual UEs with one PDSCH per virtual UE; the data transmitted over the OCNG PDSCHs shall be uncorrelated pseudo random data, which is QPSK modulated. Note 4: If the UE reports in an available uplink reporting instance at subframe SF#n based on PMI estimation at a downlink SF not later than SF#(n-4), this reported PMI cannot be applied at the eNB downlink before SF#(n+4).			

**Table 8.9.1.2.3.1-2: Minimum performance for CDM-multiplexed DM RS without simultaneous transmission (FRC) with multiple CSI-RS configurations**

Test number	Bandwidth and MCS	Reference Channel	OCNG Pattern	Propagation Condition	Correlation Matrix and Antenna Configuration	Reference value		UE DL category
						Fraction of Maximum Throughput (%)	SNR (dB)	
1	10 MHz QPSK 1/3	R.64 TDD	OP.1 TDD	EPA5	2x1 Low	70	4.5	0
2	10 MHz QPSK 1/3	R.86 TDD	OP.1 TDD	EPA5	2x1 Low	70	2.9	1bis

## 8.9.1.2.3.2 Single-layer Spatial Multiplexing with CRS assistance information

The requirements are specified in Table 8.9.1.2.3.2-2, with the addition of parameters in Table 8.9.1.2.3.2-1. In Table 8.9.1.2.3.2-1, Cell 1 is the serving cell, and Cell 2 and Cell 3 are the aggressor cells. The downlink physical channel setup is according to Annex C.3.2 for each of Cell 1, Cell 2 and Cell 3, respectively. The CRS assistance information [7] is provided to the UE and includes information on Cell 2 and Cell 3.

The purpose of the test is to verify the single-layer spatial multiplexing TM9 performance under assumption that UE applies CRS interference mitigation in the scenario with 2 CRS antenna ports in the serving and aggressor cells.

**Table 8.9.1.2.3.2-1: Test Parameters**

Parameter	Unit	Cell 1	Cell 2	Cell 3
Uplink downlink Configuration		1	1	1
Special subframe configuration		4	4	4
Downlink power allocation	$\rho_A$	dB	0	0
	$\rho_B$	dB	0 (Note 1)	0 (Note 1)
	$\sigma$	dB	-3	-3
$N_{oc}$ at antenna port	dBm/15kHz	-98	N/A	N/A
$\bar{E}_s/N_{oc}$	dB	N/A	11.75	5.69
$BW_{channel}$	MHz	10	10	10
Cyclic prefix		Normal	Normal	Normal
Subframe Configuration		Non-MBSFN	Non-MBSFN	Non-MBSFN
Cell ID		0	1	128
Cell-specific reference signals		Antenna ports 0,1		
Number of control OFDM symbols (CFI)		2	2	2
CSI reference signals		Antenna ports 15,16	N/A	N/A
CSI-RS periodicity and subframe offset $T_{CSI-RS} / \Delta_{CSI-RS}$	Subframes	5 / 4	N/A	N/A
CSI reference signal configuration		1	N/A	N/A
Zero-power CSI-RS configuration $I_{CSI-RS} / \text{ZeroPowerCSI-RS}$ bitmap	Subframes / bitmap	4 / 00100000000000	N/A	N/A
Number of control OFDM symbols		2	2	2
PDSCH transmission mode		TM9	N/A	N/A
Precoding granularity		Frequency domain: 1 PRG Time domain: 1 ms	N/A	N/A
Beamforming model		Annex B.4.1	N/A	N/A
CodeBookSubsetRestriction bitmap		001111	N/A	N/A
Time offset relative to Cell 1	$\mu\text{s}$	N/A	3	-1
Frequency shift relative to Cell 1	Hz	N/A	300	-100

Interference model			N/A	As specified in clause B.5.4	As specified in clause B.5.4
Probability of occurrence of transmission in interference cells		%	N/A	10	10
Probability of occurrence of transmission rank in interfering cells	Rank 1	%	N/A	80	80
	Rank 2	%	N/A	20	20
Note 1: $P_b = 1$ .					
Note 2: If the UE reports in an available uplink reporting instance at subframe SF #n based on PMI estimation at a downlink SF not later than SF#(n-4), this reported PMI cannot be applied at the eNB downlink before SF#(n+4).					
Note 3: SIB-1 will not be transmitted in Cell 2 and Cell 3 in this test.					

Table 8.9.1.2.3.2-2: Minimum performance for PDSCH

Test Number	Reference Channel	OCNG Pattern			Propagation Conditions (Note1)			Correlation Matrix and Antenna Configuration (Note 2)	Reference Value		UE Category
		Cell 1	Cell 2	Cell 3	Cell 1	Cell 2	Cell 3		Fraction of Maximum Throughput (%)	SNR (dB) (Note 3)	
1	R.94 TDD	OP.1 TDD	N/A	N/A	EPA5			2x1 Low	70	11.3	1bis
Note 1: The propagation conditions for Cell 1, Cell 2 and Cell 3 are statistically independent.											
Note 2: The correlation matrix and antenna configuration apply for Cell 1, Cell 2 and Cell 3.											
Note 3: SNR corresponds to $\hat{E}_s/N_{oc}$ of cell 1.											

## 8.9.2 PHICH

### 8.9.2.1 FDD and half-duplex FDD

#### 8.9.2.1.1 Transmit diversity performance

For the parameters specified in Table 8.5.1-1 the average probability of a miss-detecting ACK for NACK (Pm-an) shall be below the specified value in Table 8.9.2.1.1-1. The downlink physical setup is in accordance with Annex C.3.2.

Table 8.9.2.1.1-1: Minimum performance PHICH

Test number	Bandwidth	Reference Channel	OCNG Pattern	Propagation Condition	Antenna configuration and correlation Matrix	Reference value		UE DL category
						Pm-an (%)	SNR (dB)	
1	10 MHz	R.19	OP.1 FDD	EPA5	2 x 1 Low	0.1	8.6	0, 1bis

### 8.9.2.2 TDD

#### 8.9.2.2.1 Transmit diversity performance

For the parameters specified in Table 8.5.2-1 the average probability of a miss-detecting ACK for NACK (Pm-an) shall be below the specified value in Table 8.9.2.2.1-1. The downlink physical setup is in accordance with Annex C.3.2.

Table 8.9.2.2.1-1: Minimum performance PHICH

Test number	Bandwidth	Reference Channel	OCNG Pattern	Propagation Condition	Antenna configuration and correlation Matrix	Reference value		UE DL category
						Pm-an (%)	SNR (dB)	
1	10 MHz	R.19	OP.1 TDD	EPA5	2 x 1 Low	0.1	8.6	0, 1bis

### 8.9.3 PBCH

#### 8.9.3.1 FDD and half-duplex FDD

##### 8.9.3.1.1 Transmit diversity performance

For the parameters specified in Table 8.6.1-1 the average probability of a miss-detected PBCH (Pm-bch) shall be below the specified value in Table 8.9.3.1.1-1. The downlink physical setup is in accordance with Annex C.3.2.

Table 8.9.3.1.1-1: Minimum performance PBCH

Test number	Bandwidth	Reference Channel	Propagation Condition	Antenna configuration and correlation Matrix	Reference value		UE DL category
					Pm-bch (%)	SNR (dB)	
1	1.4 MHz	R.22	EPA5	2 x 1 Low	1	-1.3	0, 1bis

#### 8.9.3.2 TDD

##### 8.9.3.2.1 Transmit diversity performance

For the parameters specified in Table 8.6.2-1 the average probability of a miss-detected PBCH (Pm-bch) shall be below the specified value in Table 8.9.3.2.1-1. The downlink physical setup is in accordance with Annex C.3.2.

Table 8.9.3.2.1-1: Minimum performance PBCH

Test number	Bandwidth	Reference Channel	Propagation Condition	Antenna configuration and correlation Matrix	Reference value		UE DL category
					Pm-bch (%)	SNR (dB)	
1	1.4 MHz	R.22	EPA5	2 x 1 Low	1	-1.7	0, 1bis

### 8.9.4 PDCCH/PCFICH

#### 8.9.4.1 FDD and half-duplex FDD

##### 8.9.4.1.1 Enhanced Downlink Control Channel Performance Requirement Type A - 2 Tx Antenna Port with Non-Colliding CRS Dominant Interferer

The purpose of this test is to verify the Enhanced Downlink Control Channel Performance Requirement Type A for PDCCH/PCFICH with 2 transmit antennas for the case of dominant interferer with the non-colliding CRS pattern and applying interference model defined in clause B.7.1. For the parameters specified in Table 8.4.1-1 and Table 8.9.4.1.1-1, the average probability of a missed downlink scheduling grant (Pm-dsg) shall be below the specified value in Table 8.9.4.1.1-2. In Table 8.9.4.1.1-1, Cell 1 is the serving cell, and Cell 2 and Cell 3 are the aggressor cells. The downlink

physical channel setup is according to Annex C.3.2 for each of Cell 1, Cell 2 and Cell 3, respectively. The CRS assistance information [7] is provided and includes Cell 2 and Cell 3.

**Table 8.9.4.1.1-1: Test Parameters for PDCCH/PCFICH**

Parameter	Unit	Cell 1	Cell 2	Cell 3	
Downlink power allocation	PDCCH_RA OCNG_RA	dB	-3	-3	-3
	PHICH_RA	dB	-3	N/A	N/A
	PCFICH_RB PDCCH_RB OCNG_RB	dB	-3	-3	-3
	PHICH_RB	dB	-3	N/A	N/A
	Cell-specific reference signals		Antenna ports 0,1	Antenna ports 0,1	Antenna ports 0,1
$N_{oc}$ at antenna port	dBm/15kHz	-98			
$\bar{E}_s/N_{oc}$	dB	As defined in Table 8.9.4.1.1- 2	13.91	3.34	
$BW_{Channel}$	MHz	10	10	10	
Cyclic Prefix		Normal	Normal	Normal	
Cell Id		0	1	6	
Subframe Configuration		Non-MBSFN	Non-MBSFN	Non-MBSFN	
Number of DL control region OFDM symbols		1	1	1	
CFI indicated in PCFICH		1	1	1	
PHICH Ng (Note 1)		1/6	N/A	N/A	
PHICH duration		Normal	N/A	N/A	
PDSCH TM		4	N/A	N/A	
Interference model		NA	As specified in clause B.7.1	As specified in clause B.7.1	
Unused RE-s and PRB-s (Note 2)		OCNG	OCNG	OCNG	
Time Offset relative to Cell 1	$\mu$ s	N/A	2	3	
Frequency shift relative to Cell 1	Hz	N/A	200	300	
Note 1: According to Clause 6.9 in TS 36.211 [4].					
Note 2: For Cell 2 and Cell 3 unused RE-s and PRB-s do not include control region REs.					

**Table 8.9.4.1.1-2: Minimum Performance for PDCCH/PCFICH for Enhanced Downlink Control Channel Performance Requirement Type A**

Test Number	Aggregation level	Reference Channel	OCNG Pattern (Note 1)	Propagation Conditions (Note 2)			Antenna Configuration and Correlation Matrix (Note 3)	Reference Value	
				Cell 1	Cell 2	Cell 3		Pm-dsg (%)	SNR (dB) (Note 4)
1	4 CCE	R.16-4 FDD	OP.1 FDD	EPA5	EPA5	EPA5	2x1 Low	1	16.0
Note 1: The OCNG pattern applies for Cell 1, Cell 2 and Cell 3.									
Note 2: The propagation conditions for Cell 1, Cell 2 and Cell 3 are statistically independent.									
Note 3: The correlation matrix and antenna configuration apply for Cell 1, Cell 2 and Cell 3.									
Note 4: SNR corresponds to $\bar{E}_s/N_{oc}$ of Cell 1 as defined in clause 8.1.1.									

#### 8.9.4.1.2 Enhanced Downlink Control Channel Performance Requirement Type A - 4 Tx Antenna Port with Non-Colliding CRS Dominant Interferer

The purpose of this test is to verify the Enhanced Downlink Control Channel Performance Requirement Type A for PDCCH/PCFICH with 4 transmit antennas for the case of dominant interferer with the non-colliding CRS pattern and applying interference model defined in clause B.7.1.

For the parameters specified in Table 8.4.1-1 and Table 8.9.4.1.2-1, the average probability of a missed downlink scheduling grant (Pm-dsg) shall be below the specified value in Table 8.9.4.1.2-2. In Table 8.9.4.1.2-1, Cell 1 is the serving cell, and Cell 2 and Cell 3 are the aggressor cells. The downlink physical channel setup is according to Annex



C.3.2 for each of Cell 1, Cell 2 and Cell 3, respectively. The CRS assistance information [7] is provided and includes information on Cell 2 and Cell 3.

**Table 8.9.4.1.2-1: Test Parameters for PDCCH/PCFICH**

Parameter		Unit	Cell 1	Cell 2	Cell 3
Downlink power allocation	PDCCH_RA	dB	-3	-3	-3
	OCNG_RA				
	PHICH_RA	dB	-3	N/A	N/A
	PCFICH_RB				
	PDCCH_RB	dB	-3	-3	-3
	OCNG_RB				
	PHICH_RB	dB	-3	N/A	N/A
Cell-specific reference signals		Antenna ports 0,1,2,3			
$N_{oc}$ at antenna port		dBm/15kHz	-98		
$\hat{E}_s/N_{oc}$		dB	As defined in Table 8.9.4.1.2-2	13.91	3.34
BW <sub>Channel</sub>		MHz	10	10	10
Cyclic Prefix			Normal	Normal	Normal
Cell ID			0	1	6
Subframe Configuration			Non-MBSFN	Non-MBSFN	Non-MBSFN
Number of DL control region OFDM symbols			2	2	2
CFI indicated in PCFICH			2	2	2
PHICH Ng (Note 1)			1/6	N/A	N/A
PHICH duration			Normal	N/A	N/A
PDSCH TM			4	N/A	N/A
Interference model			NA	As specified in clause B.7.1	As specified in clause B.7.1
Unused RE-s and PRB-s (Note 2)			OCNG	OCNG	OCNG
Time Offset relative to Cell 1		µs	N/A	2	3
Frequency shift relative to Cell 1		Hz	N/A	200	300
Note 1: According to Clause 6.9 in TS 36.211 [4].					
Note 2: For Cell 2 and Cell 3 unused RE-s and PRB-s do not include control region REs.					

**Table 8.9.4.1.2-2: Minimum Performance for PDCCH/PCFICH for Enhanced Downlink Control Channel Performance Requirement Type A**

Test Number	Aggregation level	Reference Channel	OCNG Pattern (Note 1)	Propagation Conditions (Note 2)			Antenna Configuration and Correlation Matrix (Note 3)	Reference Value	
				Cell 1	Cell 2	Cell 3		Pm-dsg (%)	SNR (dB) (Note 4)
1	4 CCE	R.17-3 FDD	OP.1 FDD	EPA5	EPA5	EPA5	4x1 Low	1	15.4
Note 1: The OCNG pattern applies for Cell 1, Cell 2 and Cell 3.									
Note 2: The propagation conditions for Cell 1, Cell 2 and Cell 3 are statistically independent.									
Note 3: The correlation matrix and antenna configuration apply for Cell 1, Cell 2 and Cell 3.									
Note 4: SNR corresponds to $\hat{E}_s/N_{oc}$ of Cell 1 as defined in clause 8.1.1.									

8.9.4.2 TDD

8.9.4.2.1 Enhanced Downlink Control Channel Performance Requirement Type A - 2 Tx Antenna Port with Non-Colliding CRS Dominant Interferer

The purpose of this test is to verify the Enhanced Downlink Control Channel Performance Requirement Type A for PDCCH/PCFICH with 2 transmit antennas for the case of dominant interferer with the non-colliding CRS pattern and applying interference model defined in clause B.7.1. For the parameters specified in Table 8.4.2-1 and Table 8.9.4.2.1-1, the average probability of a missed downlink scheduling grant (Pm-dsg) shall be below the specified value in Table 8.9.4.2.1-2. In Table 8.9.4.2.1-1, Cell 1 is the serving cell, and Cell 2 and Cell 3 are the aggressor cells. The downlink

physical channel setup is according to Annex C.3.2 for each of Cell 1, Cell 2 and Cell 3, respectively. The CRS assistance information [7] is provided and includes Cell 2 and Cell 3.

**Table 8.9.4.2.1-1: Test Parameters for PDCCH/PCFICH**

Parameter	Unit	Cell 1	Cell 2	Cell 3	
Downlink power allocation	PDCCH_RA OCNG_RA	dB	-3	-3	-3
	PHICH_RA	dB	-3	N/A	N/A
	PCFICH_RB PDCCH_RB OCNG_RB	dB	-3	-3	-3
	PHICH_RB	dB	-3	N/A	N/A
	Cell-specific reference signals		Antenna ports 0,1	Antenna ports 0,1	Antenna ports 0,1
$N_{oc}$ at antenna port	dBm/15kHz	-98			
$\bar{E}_s/N_{oc}$	dB	As defined in Table 8.9.4.2.1- 2	13.91	3.34	
$BW_{Channel}$	MHz	10	10	10	
Cyclic Prefix		Normal	Normal	Normal	
Cell Id		0	1	6	
Subframe Configuration		Non-MBSFN	Non-MBSFN	Non-MBSFN	
Number of DL control region OFDM symbols		1	1	1	
CFI indicated in PCFICH		1	1	1	
PHICH Ng (Note 1)		1/6	N/A	N/A	
PHICH duration		Normal	N/A	N/A	
PDSCH TM		4	N/A	N/A	
Interference model		NA	As specified in clause B.7.1	As specified in clause B.7.1	
Unused RE-s and PRB-s (Note 2)		OCNG	OCNG	OCNG	
Time Offset relative to Cell 1	$\mu$ s	N/A	2	3	
Frequency shift relative to Cell 1	Hz	N/A	200	300	
Note 1: According to Clause 6.9 in TS 36.211 [4].					
Note 2: For Cell 2 and Cell 3 unused RE-s and PRB-s do not include control region REs.					

**Table 8.9.4.2.1-2: Minimum Performance for PDCCH/PCFICH for Enhanced Downlink Control Channel Performance Requirement Type A**

Test Number	Aggregation level	Reference Channel	OCNG Pattern (Note 1)	Propagation Conditions (Note 2)			Antenna Configuration and Correlation Matrix (Note 3)	Reference Value	
				Cell 1	Cell 2	Cell 3		Pm-dsg (%)	SNR (dB) (Note 4)
1	4 CCE	R.16-4 TDD	OP.1 TDD	EPA5	EPA5	EPA5	2x1 Low	1	16.9
Note 1: The OCNG pattern applies for Cell 1, Cell 2 and Cell 3.									
Note 2: The propagation conditions for Cell 1, Cell 2 and Cell 3 are statistically independent.									
Note 3: The correlation matrix and antenna configuration apply for Cell 1, Cell 2 and Cell 3.									
Note 4: SNR corresponds to $\bar{E}_s/N_{oc}$ of Cell 1 as defined in clause 8.1.1.									

#### 8.9.4.2.2 Enhanced Downlink Control Channel Performance Requirement Type A - 4 Tx Antenna Port with Non-Colliding CRS Dominant Interferer

The purpose of this test is to verify the Enhanced Downlink Control Channel Performance Requirement Type A for PDCCH/PCFICH with 4 transmit antennas for the case of dominant interferer with the non-colliding CRS pattern and applying interference model defined in clause B.7.1.

For the parameters specified in Table 8.4.2-1 and Table 8.9.4.2.2-1, the average probability of a missed downlink scheduling grant (Pm-dsg) shall be below the specified value in Table 8.9.4.2.2-2. In Table 8.9.4.2.2-1, Cell 1 is the serving cell, and Cell 2 and Cell 3 are the aggressor cells. The downlink physical channel setup is according to Annex

C.3.2 for each of Cell 1, Cell 2 and Cell 3, respectively. The CRS assistance information [7] is provided and includes information on Cell 2 and Cell 3.

**Table 8.9.4.2.2-1: Test Parameters for PDCCH/PCFICH**

Parameter	Unit	Cell 1	Cell 2	Cell 3	
Downlink power allocation	PDCCH_RA	dB	-3	-3	-3
	OCNG_RA				
	PHICH_RA	dB	-3	N/A	N/A
	PCFICH_RB				
	PDCCH_RB OCNG_RB	dB	-3	-3	-3
	PHICH_RB	dB	-3	N/A	N/A
Cell-specific reference signals		Antenna ports 0,1,2,3			
$N_{oc}$ at antenna port	dBm/15kHz	-98			
$\hat{E}_s/N_{oc}$	dB	As defined in Table 8.9.4.2.2-2	13.91	3.34	
$BW_{Channel}$	MHz	10	10	10	
Cyclic Prefix		Normal	Normal	Normal	
Cell ID		0	1	6	
Subframe Configuration		Non-MBSFN	Non-MBSFN	Non-MBSFN	
Number of DL control region OFDM symbols		2	2	2	
CFI indicated in PCFICH		2	2	2	
PHICH Ng (Note 1)		1/6	N/A	N/A	
PHICH duration		Normal	N/A	N/A	
PDSCH TM		4	N/A	N/A	
Interference model		NA	As specified in clause B.7.1	As specified in clause B.7.1	
Unused RE-s and PRB-s (Note 2)		OCNG	OCNG	OCNG	
Time Offset relative to Cell 1	$\mu$ s	N/A	2	3	
Frequency shift relative to Cell 1	Hz	N/A	200	300	
Note 1: According to Clause 6.9 in TS 36.211 [4].					
Note 2: For Cell 2 and Cell 3 unused RE-s and PRB-s do not include control region REs.					

**Table 8.9.4.2.2-2: Minimum Performance for PDCCH/PCFICH for Enhanced Downlink Control Channel Performance Requirement Type A**

Test Number	Aggregation level	Reference Channel	OCNG Pattern (Note 1)	Propagation Conditions (Note 2)			Antenna Configuration and Correlation Matrix (Note 3)	Reference Value	
				Cell 1	Cell 2	Cell 3		Pm-dsg (%)	SNR (dB) (Note 4)
1	4 CCE	R.17-3 TDD	OP.1 TDD	EPA5	EPA5	EPA5	4x1 Low	1	15.6
Note 1: The OCNG pattern applies for Cell 1, Cell 2 and Cell 3.									
Note 2: The propagation conditions for Cell 1, Cell 2 and Cell 3 are statistically independent.									
Note 3: The correlation matrix and antenna configuration apply for Cell 1, Cell 2 and Cell 3.									
Note 4: SNR corresponds to $\hat{E}_s/N_{oc}$ of Cell 1 as defined in clause 8.1.1.									

## 8.10 Demodulation (4 receiver antenna ports)

The performance requirements specified in this clause are valid for 4Rx capable UEs.

### 8.10.1 PDSCH

#### 8.10.1.1 FDD (Fixed Reference Channel)

The parameters specified in Table 8.10.1.1-1 are valid for all FDD tests unless otherwise stated.

**Table 8.10.1.1-1: Common Test Parameters (FDD)**

Parameter	Unit	Value
Inter-TTI Distance		1
Number of HARQ processes per component carrier	Processes	8
Maximum number of HARQ transmission		4
Redundancy version coding sequence		{0,1,2,3} for QPSK and 16QAM {0,0,1,2} for 64QAM, 256QAM and 1024QAM
Number of OFDM symbols for PDCCH	OFDM symbols	4 for 1.4 MHz bandwidth, 3 for 3 MHz and 5 MHz bandwidths, 2 for 10 MHz, 15 MHz and 20 MHz bandwidths unless otherwise stated
Precoder update granularity		Frequency domain: 1 PRG for Transmission modes 9 and 10 Time domain: 1 ms
Cyclic Prefix		Normal
Cell_ID		0
Cross carrier scheduling		Not configured

#### 8.10.1.1.1 Transmit diversity performance with 2Tx Antenna Ports (Cell-Specific Reference Symbols)

The requirements are specified in Table 8.10.1.1.1-2, with the addition of the parameters in Table 8.10.1.1.1-1 and the downlink physical channel setup according to Annex C.3.2. The purpose is to verify the performance of transmit diversity (SFBC) with 2 transmitter antennas.

**Table 8.10.1.1-1: Test Parameters for Transmit diversity Performance (FRC) with 4 RX Antenna Ports**

Parameter	Unit	Test 1
Downlink power allocation	$\rho_A$	dB -3
	$\rho_B$	dB -3 (NOTE 1)
	$\sigma$	dB 0
$N_{oc}$ at antenna port		dBm/15kHz -98
PDSCH transmission mode		2
NOTE 1: $P_B = 1$ .		

**Table 8.10.1.1-2: Minimum performance Transmit Diversity (FRC) with 4 RX Antenna Ports**

Test number	Bandwidth and MCS	Reference Channel	OCNG Pattern	Propagation Condition	Correlation Matrix and Antenna Configuration	Reference value		UE Category
						Fraction of Maximum Throughput (%)	SNR (dB)	
1	10 MHz 16QAM 1/2	R.11 FDD	OP.1 FDD	EVA5	2x4 Medium correlation A, ULA	70	3.9	$\geq 2$

### 8.10.1.1.1A Transmit diversity performance with Enhanced Performance Requirement Type A - 2 Tx Antenna Ports with TM3 interference model

The requirements are specified in Table 8.10.1.1.1A-2, with the addition of parameters in Table 8.10.1.1.1A-1 and the downlink physical channel setup according to Annex C.3.2. The purpose is to verify the performance of transmit diversity (SFBC) with 2 transmit antennas when the PDSCH transmission in the serving cell is interfered by PDSCH of one dominant interfering cells applying transmission mode 3 interference model defined in clause B.5.2. In Table 8.10.1.1.1A-1, Cell 1 is the serving cell, and Cell 2 is an interfering cell. The downlink physical channel setup is according to Annex C.3.2 for each of Cell 1 and Cell 2, respectively.

**Table 8.10.1.1.1A-1: Test Parameters for Transmit diversity Performance (FRC) with TM3 interference model**

Parameter		Unit	Cell 1	Cell 2
Downlink power allocation	$\rho_A$	dB	-3	-3
	$\rho_B$	dB	-3 (NOTE 1)	-3
	$\sigma$	dB	0	0
Cell-specific reference signals			Antenna ports 0,1	Antenna ports 0,1
$N_{oc}$ at antenna port		dBm/15kHz	-98	N/A
DIP (NOTE 2)		dB	N/A	-2.23
$BW_{Channel}$		MHz	10	10
Cyclic Prefix			Normal	Normal
Cell Id			0	1
Number of control OFDM symbols			2	2
PDSCH transmission mode			2	N/A
Interference model			N/A	As specified in clause B.5.2
Probability of occurrence of transmission rank in interfering cells	Rank 1	%	N/A	80
	Rank 2	%	N/A	20
Reporting interval		ms	5	N/A
Reporting mode			PUCCH 1-0	N/A
Physical channel for CQI reporting			PUSCH(Note 5)	N/A
cqi-pmi-ConfigurationIndex			2	N/A

NOTE 1:  $P_B = 1$

NOTE 2: The respective received power spectral density of each interfering cell relative to  $N_{oc}$  is defined by its associated DIP value as specified in clause B.5.1.

NOTE 3: Cell 1 is the serving cell. Cell 2 is the interfering cell.

NOTE 4: Cell 2 transmission is delayed with respect to Cell 1 by 0.33 ms.

NOTE 5: To avoid collisions between CQI reports and HARQ-ACK it is necessary to report both on PUSCH instead of PUCCH. PDCCH DCI format 0 shall be transmitted in downlink SF#1 and #6 to allow periodic CQI to multiplex with the HARQ-ACK on PUSCH in uplink subframe SF#5 and #0.

**Table 8.10.1.1.1A-2: Enhanced Performance Requirement Type A, Transmit Diversity (FRC) with TM3 interference model**

Test Number	Reference Channel		OCNG Pattern		Propagation Conditions		Correlation Matrix and Antenna Configuration (NOTE 3)	Reference Value		UE Category
			Cell 1	Cell 2	Cell 1	Cell 2		Fraction of Maximum Throughput (%)	SINR (dB) (NOTE 2)	
1	R.46 FDD	OP.1 FDD	N/A	EVA70	EVA70	2x4 Low	70	-4.4	≥1	
NOTE 1: The propagation conditions for Cell 1 and Cell 2 are statistically independent.										
NOTE 2: SINR corresponds to $E_s/N_{oc}$ of Cell 1 as defined in clause 8.1.1.										
NOTE 3: Correlation matrix and antenna configuration parameters apply for each of Cell 1 and Cell 2.										

**8.10.1.1.2 Open-loop spatial multiplexing performance with 2Tx Antenna Ports (Cell-Specific Reference Symbols)**

The requirements are specified in Table 8.10.1.1.2-2, with the addition of the parameters in Table 8.10.1.1.2-1 and the downlink physical channel setup according to Annex C.3.2.

**Table 8.10.1.1.2-1: Test Parameters for Large Delay CDD (FRC) with 4 RX Antenna Ports**

Parameter	Unit	Test 1	
Downlink power allocation	$\rho_A$	dB	-3
	$\rho_B$	dB	-3 (NOTE 1)
	$\sigma$	dB	0
$N_{oc}$ at antenna port	dBm/15kHz	-98	
PDSCH transmission mode		3	
NOTE 1: $P_B = 1$ .			

**Table 8.10.1.1.2-2: Minimum performance Large Delay CDD (FRC) with 4 RX Antenna Ports**

Test num	Bandwidth and MCS	Reference channel	OCNG pattern	Propagation condition	Correlation matrix and antenna config.	Reference value		UE category
						Fraction of maximum Throughput (%)	SNR (dB)	
1	10 MHz 16QAM 1/2	R.11 FDD	OP.1 FDD	EVA70	2x4 Low	70	8.0	≥2

**8.10.1.1.3 Closed-loop spatial multiplexing Enhanced Performance Requirements Type A - Single-Layer Spatial Multiplexing 2 Tx Antenna Port with TM4 interference model (Cell-Specific Reference Symbols)**

The requirements are specified in Table 8.10.1.1.3-2, with the addition of the parameters in Table 8.10.1.1.3-1 and the downlink physical channel setup according to Annex C.3.2. The purpose of these tests is to verify the closed loop rank-one performance with wideband precoding with two transmit antennas when the PDSCH transmission in the serving cell is interfered by PDSCH of one dominant interfering cell applying transmission mode 4 interference model defined in clause B.5.3. In Table 8.10.1.1.3-1, Cell 1 is the serving cell, and Cell 2 is the interfering cell. The downlink physical channel setup is according to Annex C.3.2 for each of Cell 1 and Cell 2, respectively.

**Table 8.10.1.1.3-1: Test Parameters for Single-Layer Spatial Multiplexing (FRC) with TM4 interference model and 4 RX Antenna Ports**

Parameter		Unit	Cell 1	Cell 2
Downlink power allocation	$\rho_A$	dB	-3	-3
	$\rho_B$	dB	-3 (Note 1)	-3
	$\sigma$	dB	0	0
Cell-specific reference signals			Antenna ports 0,1	Antenna ports 0,1
$N_{oc}$ at antenna port		dBm/15kHz	-98	N/A
DIP (Note 2)		dB	N/A	-1.73
$BW_{\text{channel}}$		MHz	10	10
Cell Id			0	1
PDSCH transmission mode			6	4
Interference model			N/A	As specified in clause B.5.3
Probability of occurrence of transmission rank in interfering cells	Rank 1	%	N/A	80
	Rank 2	%	N/A	20
Precoding granularity		PRB	50	6
PMI delay (Note 4)		ms	8	N/A
Reporting interval		ms	5	N/A
Reporting mode			PUCCH 1-1	N/A
CodeBookSubsetRestriction bitmap			1111	N/A

Note 1:  $P_B = 1$

Note 2: The respective received power spectral density of each interfering cell relative to  $N_{oc}$  is defined by its associated DIP value as specified in clause B.5.1.

Note 3: Cell 1 is the serving cell. Cell 2 is the interfering cell.

Note 4: If the UE reports in an available uplink reporting instance at subframe SF#n based on PMI estimation at a downlink SF not later than SF#(n-4), this reported PMI cannot be applied at the eNB downlink before SF#(n+4).

Note 5: All cells are time-synchronous.

**Table 8.10.1.1.3-2: Enhanced Performance Requirement Type A, Single-Layer Spatial Multiplexing (FRC) with TM4 interference model and 4 RX Antenna Ports**

Test Number	Reference Channel and MCS	OCNG Pattern		Propagation Conditions		Correlation Matrix and Antenna Configuration (Note 3)	Reference Value		UE Category
		Cell 1	Cell 2	Cell 1	Cell 2		Fraction of Maximum Throughput (%)	SINR (dB) (Note 2)	
1	R,47 FDD 16QAM	OP.1 FDD	N/A	EVA5	EVA5	2x4 Low	70	-2.3	≥1

Note 1: The propagation conditions for Cell 1 and Cell 2 are statistically independent.

Note 2: SINR corresponds to  $E_s/N_{oc}$  of Cell 1 as defined in clause 8.1.1.

Note 3: Correlation matrix and antenna configuration parameters apply for each of Cell 1 and Cell 2.

#### 8.10.1.1.4 Closed-loop spatial multiplexing performance, Dual-Layer Spatial Multiplexing 4 Tx Antenna Port (Cell-Specific Reference Symbols)

For single carrier, the requirements are specified in Table 8.10.1.1.4-2, with the addition of the parameters in Table 8.10.1.1.4-1 and the downlink physical channel setup according to Annex C.3.2.

**Table 8.10.1.1.4-1: Test Parameters for Dual-Layer Spatial Multiplexing (FRC) with 4 RX Antenna Ports**

Parameter	Unit	Test 1-2	Test 3
Downlink power allocation	$\rho_A$	dB	-6
	$\rho_B$	dB	-6 (Note 1)
	$\sigma$	dB	3
$N_{oc}$ at antenna port	dBm/15kHz	-98	-98
Precoding granularity	PRB	6	50
PMI delay (Note 2)	ms	8	8
Reporting interval	ms	1	1
Reporting mode		PUSCH 1-2	PUSCH 3-1
CodeBookSubsetRestriction bitmap		00000000000000000000000000000000 0000111111111111111111111111111100000000 00000000	00000000000000000000000000000000 0000111111111111111111111111111100000000 00000000
PDSCH transmission mode		4	4
Note 1: $P_B = 1$ .			
Note 2: If the UE reports in an available uplink reporting instance at subframe SF#n based on PMI estimation at a downlink SF not later than SF#(n-4), this reported PMI cannot be applied at the eNB downlink before SF#(n+4).			

**Table 8.10.1.1.4-2: Minimum performance Dual-Layer Spatial Multiplexing (FRC) with 4 RX Antenna Ports**

Test num.	Bandwidth and MCS	Referenc echannel	OCNG pattern	Propa- gation condition	Correlation matrix and antenna config.	Reference value		UE category	DL UE category
						Fraction of maximum throughput (%)	SNR (dB)		
1	10 MHz	R.36 FDD	OP.1 FDD	EPA5	4x4 Low	70	10.1	≥2	≥6
2	10 MHz 256 QAM	R.72 FDD	OP.1 FDD	EPA5	4x4 Low	70	18.0	11-12	≥11
3	10MHz 1024QA M	R.102 FDD	OP.1 FDD	EPA5	4x4 Low	70	27.7	TBD	20, ≥ 22

#### 8.10.1.1.4A Enhanced Performance Requirement Type C - Dual-Layer Spatial Multiplexing with 2Tx Antenna Ports

The requirements are specified in Table 8.10.1.1.4A-2, with the addition of the parameters in Table 8.10.1.1.4A-1 and the downlink physical channel setup according to Annex C.3.2. The purpose of these tests is to verify the closed loop rank-two performance with wideband precoding.



**Table 8.10.1.1.4A-1: Test Parameters for Dual-Layer Spatial Multiplexing (FRC)**

Parameter	Unit	Test 1
Downlink power allocation	$\rho_A$	-3
	$\rho_B$	-3 (Note 1)
	$\sigma$	0
$N_{oc}$ at antenna port	dBm/15kHz	-98
Precoding granularity	PRB	50
PMI delay (Note 2)	ms	8
Reporting interval	ms	1
Reporting mode		PUSCH 3-1
CodeBookSubsetRestriction bitmap		110000
PDSCH transmission mode		4
Note 1: $P_B = 1$ .		
Note 2: If the UE reports in an available uplink reporting instance at subframe SF#n based on PMI estimation at a downlink SF not later than SF#(n-4), this reported PMI cannot be applied at the eNB downlink before SF#(n+4).		

**Table 8.10.1.1.4A-2: Enhanced Performance Requirement Type C for Dual-Layer Spatial Multiplexing with TM4 (FRC)**

Test number	Bandwidth	Reference Channel	OCNG Pattern	Propagation Condition	Correlation Matrix and Antenna Configuration	Reference value		UE Category
						Fraction of Maximum Throughput (%)	SNR (dB)	
1	10 MHz	R.11 FDD	OP.1 FDD	ETU70	2x4 Medium	70	16.8	$\geq 2$

#### 8.10.1.1.5 Enhanced Performance Requirement Type A – Single-layer Spatial Multiplexing with TM9 interference model (User-Specific Reference Symbols)

The requirements are specified in Table 8.10.1.1.5-2, with the addition of the parameters in Table 8.10.1.1.5-1 and the downlink physical channel setup according to Annex C.3.2. The purpose of these tests is to verify closed loop rank one performance on one of the antenna ports 7 or 8 without a simultaneous transmission on the other antenna port in the serving cell when the PDSCH transmission in the serving cell is interfered by PDSCH of one dominant interfering cell applying transmission mode 9 interference model defined in clause B.5.4. In 8.10.1.1.5-1, Cell 1 is the serving cell, and Cell 2 is the interfering cell. The downlink physical channel setup is according to Annex C.3.2 for each of Cell 1 and Cell 2, respectively.

**Table 8.10.1.1.5-1: Test Parameters for Testing CDM-multiplexed DM RS (single layer) with TM9 interference model and 4 RX Antenna Ports**

parameter		Unit	Cell 1	Cell 2
Downlink power allocation	$\rho_A$	dB	0	0
	$\rho_B$	dB	0 (Note 1)	0
	$\sigma$	dB	-3	-3
Cell-specific reference signals			Antenna ports 0,1	Antenna ports 0,1
CSI reference signals			Antenna ports 15,16	N/A
CSI-RS periodicity and subframe offset $T_{\text{CSI-RS}} / \Delta_{\text{CSI-RS}}$		Subframes	5 / 2	N/A
CSI reference signal configuration			0	N/A
$N_{oc}$ at antenna port		dBm/15kHz	-98	N/A
DIP (Note 2)		dB	N/A	-1.73
$BW_{\text{Channel}}$		MHz	10	10
Cell Id			0	126
PDSCH transmission mode			9	9
Beamforming model			As specified in clause B.4.3 (Note 4, 5)	N/A
Interference model			N/A	As specified in clause B.5.4
Probability of occurrence of transmission rank in interfering cells	Rank 1		N/A	70
	Rank 2		N/A	30
Precoder update granularity		PRB	50	6
PMI delay (Note 5)		Ms	8	N/A
Reporting interval		Ms	5	N/A
Reporting mode			PUCCH 1-1	N/A
CodeBookSubsetRestriction bitmap			001111	N/A
Symbols for unused PRBs			OCNG (Note 6)	N/A
Simultaneous transmission			No simultaneous transmission on the other antenna port in (7 or 8) used for the input signal under test	N/A
Physical channel for CQI reporting			PUSCH(Note 8)	N/A
cqi-pmi-ConfigurationIndex			5	N/A

Note 1:	$P_B = 1$
Note 2:	The respective received power spectral density of each interfering cell relative to $N_{oc}'$ is defined by its associated DIP value as specified in clause B.5.1.
Note 3:	The modulation symbols of the signal under test in Cell 1 are mapped onto antenna port 7 or 8.
Note 4:	The precoder in clause B.4.3 follows UE recommended PMI.
Note 5:	If the UE reports in an available uplink reporting instance at subframe SF#n based on PMI estimation at a downlink SF not later than SF#(n-4), this reported PMI cannot be applied at the eNB downlink before SF#(n+4).
Note 6:	These physical resource blocks are assigned to an arbitrary number of virtual UEs with one PDSCH per virtual UE; the data transmitted over the OCNG PDSCHs shall be uncorrelated pseudo random data, which is QPSK modulated.
Note 7:	All cells are time-synchronous.
Note 8:	To avoid collisions between CQI reports and HARQ-ACK it is necessary to report both on PUSCH instead of PUCCH. PDCCH DCI format 0 shall be transmitted in downlink SF#4 and #9 to allow periodic CQI to multiplex with the HARQ-ACK on PUSCH in uplink subframe SF#8 and #3.

**Table 8.10.1.1.5-2: Enhanced Performance Requirement Type A, CDM-multiplexed DM RS with TM9 interference model and 4 RX Antenna Ports**

Test Number	Reference Channel and MCS	OCNG Pattern		Propagation Conditions		Correlation Matrix and Antenna Configuration (Note 3)	Reference Value		UE Category
		Cell 1	Cell 2	Cell 1	Cell 2		Fraction of Maximum Throughput (%)	SINR (dB) (Note 2)	
1	R. 76 FDD QPSK	OP.1 FDD	N/A	EVA5	EVA5	2x4 Low	70	-3.0	≥1
Note 1: The propagation conditions for Cell 1 and Cell 2 are statistically independent.									
Note 2: SINR corresponds to $E_s/N_{oc}'$ of Cell 1 as defined in clause 8.1.1.									
Note 3: Correlation matrix and antenna configuration parameters apply for each of Cell 1 and Cell 2.									

#### 8.10.1.1.5A Single-layer Spatial Multiplexing (User-Specific Reference Symbols)

The requirements are specified in Table 8.10.1.1.5A-2, with the addition of the parameters in Table 8.10.1.1.5A-1 and the downlink physical channel setup according to Annex C.3.2. The purpose of these tests is to verify closed loop rank one performance on one of the antenna ports 7 or 8 with a simultaneous transmission on the other antenna port in the serving cell, and to verify rate matching with multiple CSI reference symbol configurations with non-zero and zero transmission power.

**Table 8.10.1.1.5A-1: Test Parameters for Testing CDM-multiplexed DM RS (single layer) with multiple CSI-RS configurations**

Parameter		Unit	Test 1
Downlink power allocation	$\rho_A$	dB	0
	$\rho_B$	dB	0 (Note 1)
	$\sigma$	dB	-3

Beamforming model		Annex B.4.1
Cell-specific reference signals		Antenna ports 0,1
CSI reference signals		Antenna ports 15,...,18
CSI-RS periodicity and subframe offset $T_{\text{CSI-RS}} / \Delta_{\text{CSI-RS}}$	Subframes	5 / 2
CSI reference signal configuration		3
Zero-power CSI-RS configuration $I_{\text{CSI-RS}} / \text{ZeroPowerCSI-RS bitmap}$	Subframes / bitmap	3 / 0001000000000000
$N_{oc}$ at antenna port	dBm/15kHz	-98
Symbols for unused PRBs		OCNG (Note 4)
Number of allocated resource blocks (Note 2)	PRB	50
Simultaneous transmission		Yes (Note 3, 5)
PDSCH transmission mode		9
Number of MBSFN subframes	Subframes	NA
<p>Note 1: <math>P_B = 1</math>.</p> <p>Note 2: The modulation symbols of the signal under test are mapped onto antenna port 7 or 8.</p> <p>Note 3: Modulation symbols of an interference signal is mapped onto the antenna port (7 or 8) not used for the input signal under test.</p> <p>Note 4: These physical resource blocks are assigned to an arbitrary number of virtual UEs with one PDSCH per virtual UE; the data transmitted over the OCNG PDSCHs shall be uncorrelated pseudo random data, which is QPSK modulated.</p> <p>Note 5: The two UEs' scrambling identities <math>n_{\text{SCID}}</math> are set to 0 for CDM-multiplexed DM RS with interfering simultaneous transmission test cases.</p>		

**Table 8.10.1.1.5A-2: Minimum performance for CDM-multiplexed DM RS with interfering simultaneous transmission (FRC) with multiple CSI-RS configurations**

Test number	Bandwidth and MCS	Reference Channel	OCNG Pattern	Propagation Condition	Correlation Matrix and Antenna Configuration	Reference value		UE Category
						Fraction of Maximum Throughput (%)	SNR (dB)	
1	10 MHz 64QAM 1/2	R.50 FDD	OP.1 FDD	EPA5	2x4 Low	70	15.8	≥2

Note 1: The reference channel applies to both the input signal under test and the interfering signal.

#### 8.10.1.1.5B Single-layer Spatial Multiplexing (With Enhanced DMRS table configured)

For single-layer transmission on antenna port 7, 8, 11 or 13 upon detection of a PDCCH with DCI format 2C, the requirement is specified in Table 8.10.1.1.5B-2, with the addition of the parameters in Table 8.10.1.1.5B-1 and the downlink physical channel setup according to Annex C.3.2. The purpose of the test is to verify rank-1 performance on antenna port 11 with a simultaneous transmission on the antenna port 7, 8 or 13 with DMRS enhancement table and 4 orthogonal DMRS ports (dmrs-Enhancements-r13 UE-EUTRA-Capability [7]).

**Table 8.10.1.1.5B-1: Test Parameters for Testing CDM-multiplexed DM RS (single layer) with interfering simultaneous transmission (FRC) with multiple CSI-RS configurations with Enhanced DMRS table**

Parameter	Unit	Test 1
Downlink power allocation	$\rho_A$	dB
	$\rho_B$	dB
	$\sigma$	dB
Beamforming model		Annex B.4.1A
Cell-specific reference signals		Antenna ports 0,1
CSI reference signals		Antenna ports 15,...,18
CSI-RS periodicity and subframe offset $T_{\text{CSI-RS}} / \Delta_{\text{CSI-RS}}$	Subframes	5 / 2
CSI reference signal configuration		3
Zero-power CSI-RS configuration $I_{\text{CSI-RS}} / \text{ZeroPowerCSI-RS bitmap}$	Subframes / bitmap	3 / 0001000000000000
$N_{oc}$ at antenna port	dBm/15kHz	-98
Symbols for unused PRBs		OCNG (Note 4)
Number of allocated resource blocks (Note 2)	PRB	50
Simultaneous transmission		Yes (Note 3, 5)
dmsr-Enhancements-r13		Enable
PDSCH transmission mode		9
Note 1: $P_B = 1$ . Note 2: The modulation symbols of the signal under test are mapped onto antenna port 11. Note 3: Modulation symbols of an interference signal are random mapped onto one antenna port among antenna port 7, 8 and 13. The update granularity for randomized mapping antenna port is 1 PRG in frequency domain and 1ms in time domain. Note 4: These physical resource blocks are assigned to an arbitrary number of virtual UEs with one PDSCH per virtual UE; the data transmitted over the OCNG PDSCHs shall be uncorrelated pseudo random data, which is QPSK modulated. Note 5: The two UEs' scrambling identities $n_{\text{SCID}}$ are set to 0 with OCC =4.		

**Table 8.10.1.1.5B-2: Minimum performance for CDM-multiplexed DM RS with interfering simultaneous transmission (FRC) with multiple CSI-RS configurations with Enhanced DMRS table**

Test number	Bandwidth and MCS	Reference Channel	OCNG Pattern	Propagation Condition	Correlation Matrix and Antenna Configuration	Reference value		UE Category
						Fraction of Maximum Throughput (%)	SNR (dB)	
1	10 MHz 64QAM 1/2	R.50 FDD	OP.1 FDD	EPA5	2x4 Low	70	15.8	$\geq 2$
Note 1: The reference channel applies to both the input signal under test and the interfering signal.								

#### 8.10.1.1.6 Dual-Layer Spatial Multiplexing (User-Specific Reference Symbols)

For dual-layer transmission on antenna ports 7 and 8 upon detection of a PDCCH with DCI format 2C, the requirements are specified in Table 8.10.1.1.6-2, with the addition of the parameters in Table 8.10.1.1.6-1 where Cell 1 is the serving cell and Cell 2 is the interfering cell. The downlink physical channel setup is set according to Annex C.3.2. The purpose of these tests is to verify the rank-2 performance for full RB allocation, to verify rate matching with multiple CSI reference symbol configurations with non-zero and zero transmission power, and to verify that the UE correctly estimate SNR.

**Table 8.10.1.1.6-1: Test Parameters for Testing CDM-multiplexed DM RS (dual layer) with multiple CSI-RS configurations with 4 RX Antenna Ports**

Parameter		Unit	Test 1	
			Cell 1	Cell 2
Downlink power allocation	$\rho_A$	dB	0	0
	$\rho_B$	dB	0 (Note 1)	0
	$\sigma$	dB	-3	-3
	PDSCH_RA	dB	4	NA
	PDSCH_RB	dB	4	NA
Cell-specific reference signals			Antenna ports 0 and 1	Antenna ports 0 and 1
Cell ID			0	126
CSI reference signals			Antenna ports 15,16	NA
Beamforming model			Annex B.4.2	NA
CSI-RS periodicity and subframe offset $T_{\text{CSI-RS}} / \Delta_{\text{CSI-RS}}$		Subframes	5 / 2	NA
CSI reference signal configuration			8	NA
Zero-power CSI-RS configuration $l_{\text{CSI-RS}} / \text{ZeroPowerCSI-RS}$ bitmap		Subframes / bitmap	3 / 0010000000000000	NA
$N_{oc}$ at antenna port		dBm/15kHz	-98	NA
$E_s / N_{oc}$			Reference Value in Table 8.10.1.1.6-2	7.25dB
Symbols for unused PRBs			OCNG (Note 2)	NA
Number of allocated resource blocks (Note 2)		PRB	50	NA
Simultaneous transmission			No	NA
PDSCH transmission mode			9	Blanked
Note 1: $P_B = 1$				
Note 2: These physical resource blocks are assigned to an arbitrary number of virtual UEs with one PDSCH per virtual UE; the data transmitted over the OCNG PDSCHs shall be uncorrelated pseudo random data, which is QPSK modulated.				

**Table 8.10.1.1.6-2: Minimum performance for CDM-multiplexed DM RS (FRC) with multiple CSI-RS configurations and 4 RX Antenna Ports**

Test number	Bandwidth and MCS	Reference Channel	OCNG Pattern		Propagation Condition		Correlation Matrix and Antenna Configuration	Reference value		UE Category
			Cell1	Cell 2	Cell 1	Cell 2		Fraction of Maximum Throughput (%)	SNR (dB)	
1	10 MHz 16QAM 1/2	R.51 FDD	OP.1 FDD	N/A	ETU5	ETU5	2x4 Low	70	9.2	$\geq 2$
Note 1: The propagation conditions for Cell 1 and Cell 2 are statistically independent.										
Note 2: Correlation matrix and antenna configuration parameters apply for each of Cell 1 and Cell 2.										
Note 3: SNR corresponds to $\bar{E}_s / N_{oc}$ of Cell 1.										

## 8.10.1.1.6A Enhanced Performance Requirement Type C - Dual-Layer Spatial Multiplexing

The requirements are specified in 8.10.1.1.6A-2, with the addition of the parameters in 8.10.1.1.6A-1 and the downlink physical channel setup according to Annex C.3.2. The purpose of this test is to verify rank-two performance for full RB allocation upon antenna ports 7 and 8.

## 8.10.1.1.6A-1: Test Parameters for Testing CDM-multiplexed DM RS (dual layer) with multiple CSI-RS configurations

parameter	Unit	Test 1
Downlink power allocation	$\rho_A$	dB
	$\rho_B$	dB
	$\sigma$	dB
Cell-specific reference signals		Antenna ports 0 and 1
CSI reference signals		Antenna ports 15,16
Beamforming model		Annex B.4.3
CSI-RS periodicity and subframe offset $T_{\text{CSI-RS}} / \Delta_{\text{CSI-RS}}$	Subframes	5 / 2
CSI reference signal configuration		8
Zero-power CSI-RS configuration $I_{\text{CSI-RS}} / \text{ZeroPowerCSI-RS}$ bitmap	Subframes / bitmap	3 / 0010000000000000
$N_{oc}$ at antenna port	dBm/15kHz	-98
Symbols for unused PRBs		OCNG (Note 2)
Number of allocated resource blocks (Note 2)	PRB	50
Simultaneous transmission		No
Reporting mode		PUSCH 3-1
PDSCH transmission mode		9
Note 1: $P_B = 1$		
Note 2: These physical resource blocks are assigned to an arbitrary number of virtual UEs with one PDSCH per virtual UE; the data transmitted over the OCNG PDSCHs shall be uncorrelated pseudo random data, which is QPSK modulated.		

## 8.10.1.1.6A-2: Enhanced Performance Requirement Type C for CDM-multiplexed DM RS (FRC) with multiple CSI-RS configurations

Test number	Bandwidth and MCS	Reference Channel	OCNG Pattern	Propagation Condition	Correlation Matrix and Antenna Configuration	Reference value		UE Category
						Fraction of Maximum Throughput (%)	SNR (dB)	
1	10 MHz 16QAM 1/2	R.51 FDD	OP.1 FDD	EPA5	2x4 Medium	70	16.2	$\geq 2$



### 8.10.1.1.6B Dual-Layer Spatial Multiplexing with altCQI-Table-1024QAM configured (User-Specific Reference Symbols)

The requirements are specified in 8.10.1.1.6B-2, with the addition of the parameters in 8.10.1.1.6B-1 and the downlink physical channel setup according to Annex C.3.2. The purpose of this test is to verify rank-two performance for full RB allocation upon antenna ports 7 and 8.

#### 8.10.1.1.6B-1: Test Parameters for Testing CDM-multiplexed DM RS (dual layer) with multiple CSI-RS configurations

parameter	Unit	Test 1
Downlink power allocation	$\rho_A$	dB
	$\rho_B$	dB
	$\sigma$	dB
Cell-specific reference signals		Antenna ports 0 and 1
CSI reference signals		Antenna ports 15,16, 17, 18
Beamforming model		Annex B.4.3
CSI-RS periodicity and subframe offset $T_{\text{CSI-RS}} / \Delta_{\text{CSI-RS}}$	Subframes	5 / 2
CSI reference signal configuration		3
Zero-power CSI-RS configuration $l_{\text{CSI-RS}} / \text{ZeroPowerCSI-RS}$ bitmap	Subframes / bitmap	N/A
$N_{oc}$ at antenna port	dBm/15kHz	-98
Symbols for unused PRBs		OCNG (Note 2)
Number of allocated resource blocks (Note 2)	PRB	50
Simultaneous transmission		No
Reporting mode		PUSCH 3-1
PDSCH transmission mode		9
Note 1: $P_B = 1$		
Note 2: These physical resource blocks are assigned to an arbitrary number of virtual UEs with one PDSCH per virtual UE; the data transmitted over the OCNG PDSCHs shall be uncorrelated pseudo random data, which is QPSK modulated.		

#### 8.10.1.1.6B-2: Minimum performance Dual-Layer Spatial Multiplexing with altCQI-Table-1024QAM

Test number	Bandwidth and MCS	Reference Channel	OCNG Pattern	Propagation Condition	Correlation Matrix and Antenna Configuration	Reference value		UE DL Category
						Fraction of Maximum Throughput (%)	SNR (dB)	
1	10 MHz 1024QAM	R.102 FDD	OP.1 FDD	EPA5	4x4 Low	70	29.4	20, $\geq 22$

### 8.10.1.1.7 Open-loop spatial multiplexing, 3 Layer Multiplexing with 4 Tx Antenna Ports (Cell-Specific Reference Symbols)

The requirements are specified in Table 8.10.1.1.7-2, with the addition of the parameters in Table 8.10.1.1.7-1 and the downlink physical channel setup according to Annex C.3.2.

**Table 8.10.1.1.7-1: Test parameters for Open Loop spatial multiplexing, 3 Layers with 4 Tx ports and 4 Rx ports**

Parameter		Unit	Test 1
Downlink power allocation	$\rho_A$	dB	-6
	$\rho_B$	dB	-6 (Note 1)
	$\sigma$	dB	0
Cell-specific reference signals			Antenna ports 0,1,2,3
$N_{oc}$ at antenna port		dBm/15k Hz	-98
PDSCH transmission mode			3
PDSCH rank			3
CodeBookSubsetRestriction bitmap			0100
Note 1: $P_B = 1$ .			

**Table 8.10.1.1.7-2: Minimum performance Open Loop spatial multiplexing, 3 Layers with 4 Tx ports and 4 Rx ports**

Test number	Bandwidth and MCS	Reference Channel	OCNG Pattern	Propagation Condition	Correlation Matrix and Antenna Configuration	Reference value		UE Category
						Fraction of Maximum Throughput (%)	SNR (dB)	
1	10 MHz 64QAM	R.73 FDD	OP.1 FDD	EVA70	4x4 Low	70	15.1	≥5

### 8.10.1.1.7A Enhanced Performance Requirement Type C - Open-loop spatial multiplexing, 3 Layer Multiplexing with 4 Tx Antenna Ports (Cell-Specific Reference Symbols)

The requirements are specified in Table 8.10.1.1.7A-2, with the addition of the parameters in Table 8.10.1.1.7A-1 and the downlink physical channel setup according to Annex C.3.2.

**Table 8.10.1.1.7A-1: Test parameters for Open Loop spatial multiplexing, 3 Layers with 4 Tx ports and 4 Rx ports**

Parameter		Unit	Test 1
Downlink power allocation	$\rho_A$	dB	-6
	$\rho_B$	dB	-6 (Note 1)
	$\sigma$	dB	0
Cell-specific reference signals			Antenna ports 1,2,3,4
$N_{oc}$ at antenna port		dBm/15k Hz	-98
PDSCH transmission mode			3
PDSCH rank			3
CodeBookSubsetRestriction bitmap			0100
Note 1: $P_B = 1$ .			

**Table 8.10.1.1.7A-2: Enhanced Performance Requirement Type C for Open Loop spatial multiplexing, 3 Layers with 4 Tx ports**

Test number	Bandwidth and MCS	Reference Channel	OCNG Pattern	Propagation Condition	Correlation Matrix and Antenna Configuration	Reference value		UE Category
						Fraction of Maximum Throughput (%)	SNR (dB)	
1	10 MHz 16QAM	R.73-1 FDD	OP.1 FDD	EVA70	4x4 Medium A	70	22.2	≥5

**8.10.1.1.8 Closed-loop spatial multiplexing performance, 4 Layers spatial multiplexing 4 Tx antennas (Cell-Specific Reference Symbols)**

The requirements are specified in Table 8.10.1.1.8-2, with the addition of the parameters in Table 8.10.1.1.8-1 and the downlink physical channel setup according to Annex C.3.2.

**Table 8.10.1.1.8-1: Test parameters for Closed Loop spatial multiplexing, 4 Layers spatial multiplexing with 4 Tx ports and 4 Rx ports**

Parameter	Unit	Test 1
Downlink power allocation	$\rho_A$	dB
	$\rho_B$	dB
	$\sigma$	dB
$N_{oc}$ at antenna port	dBm/15k Hz	-98
Cell-specific reference signals		Antenna Ports 0,1,2,3
PDSCH transmission mode		4
PDSCH rank		4
Precoding granularity	PRB	50
PMI delay	ms	8
Reporting interval	ms	1
Reporting mode		PUSCH 3-1
CodeBookSubsetRestriction bitmap		0xFFFF000000000000
Note 1: $P_B = 1$ .		

**Table 8.10.1.1.8-2: Minimum performance for Closed Loop spatial multiplexing, 4 Layers spatial multiplexing with 4 Tx ports and 4 Rx ports**

Test number	Bandwidth and MCS	Reference Channel	OCNG Pattern	Propagation Condition	Correlation Matrix and Antenna Configuration	Reference value		UE Category
						Fraction of Maximum Throughput (%)	SNR (dB)	
1	10 MHz 16QAM 1/2	R.74 FDD	OP.1 FDD	EPA5	4x4 Low	70	14.9	≥5

**8.10.1.1.9 4 Layer Spatial Multiplexing (User-Specific Reference Symbols)**

The requirements are specified in Table 8.10.1.1.9-2, with the addition of the parameters in Table 8.10.1.1.9-1 and the downlink physical channel setup according to Annex C.3.2.

**Table 8.10.1.1.9-1: Minimum performance for 4 Layer Spatial Multiplexing (User-Specific Reference Symbols)**

Parameter	Unit	Test 1	Test 1a	
Downlink power allocation	$\rho_A$	dB	0	0
	$\rho_B$	dB	0 (Note 1)	0 (Note 1)
	$\sigma$	dB	-3	-3
Beamforming model		4 layer precoding based on WB PMI feedback	4 layer precoding based on WB PMI feedback	
Cell-specific reference signals		Antenna ports 0,1	Antenna ports 0,1	
CSI reference signals		Antenna ports 15,...,18	Antenna ports 15,...,18	
Beamforming model		Annex B.4.3	Annex B.4.3	
CSI-RS periodicity and subframe offset $T_{CSI-RS} / \Delta_{CSI-RS}$	Subframes	5 / 2	5 / 2	
CSI reference signal configuration		3	3	
Zero-power CSI-RS configuration $I_{CSI-RS} /$ ZeroPowerCSI-RS bitmap	Subframes / bitmap	3 / 0001000000000000	3 / 0001000000000000	
$N_{oc}$ at antenna port	dBm/15kHz	-98	-98	
Symbols for unused PRBs		OCNG (Note 3)	OCNG (Note 3)	
Number of allocated resource blocks (Note 2)	PRB	50	50	
Simultaneous transmission		No	No	
PDSCH transmission mode		9	9	
Precoding granularity		50	50	
PMI delay		8	8	
Reporting interval		1	1	
Reporting mode		PUSCH 3-1	PUSCH 3-1	
alternativeCodeBookEnabledFor4TX-r12		False	False	
CodeBookSubsetRestriction bitmap		0xFFFF000000000000	0xFFFF000000000000	
DMRS OCC length per port		2	4	
<p>Note 1: <math>P_B = 1</math>.</p> <p>Note 2: 50 resource blocks are allocated in sub-frames 1,2,3,4,6,7,8,9 and 41 resource blocks (RB0–RB20 and RB30–RB49) are allocated in sub-frame 0.</p> <p>Note 3: These physical resource blocks are assigned to an arbitrary number of virtual UEs with one PDSCH per virtual UE; the data transmitted over the OCNG PDSCHs shall be uncorrelated pseudo random data, which is QPSK modulated.</p>				

**Table 8.10.1.1.9-2: Minimum performance for 4 Layer Spatial Multiplexing (User-Specific Reference Symbols)**

Test number	Bandwidth and MCS	Reference Channel	OCNG Pattern	Propagation Condition	Correlation Matrix and Antenna Configuration	Reference value		UE Category
						Fraction of Maximum Throughput (%)	SNR (dB)	
1	10 MHz 16QAM	R.75 FDD	OP.1 FDD	EPA5	4x4 Low	70	18.4	≥5
1a	10MHz 16QAM	R.75A FDD	OP.1 FDD	EPA5	4x4 Low	70	[17.4]	≥5
NOTE: For a UE supporting TM9 rank3/4 transmission based on DMRS OCC length 4, Test 1a will be run and Test 1 will be skipped. Otherwise, Test 1a is not applicable and only Test 1 will be run.								

### 8.10.1.1.9A Enhanced Performance Requirement Type C - 4 Layer Spatial Multiplexing (User-Specific Reference Symbols)

The requirements are specified in Table 8.10.1.1.9A-2, with the addition of the parameters in Table 8.10.1.1.9A-1 and the downlink physical channel setup according to Annex C.3.2.

**Table 8.10.1.1.9A-1: Minimum performance for 4 Layer Spatial Multiplexing (User-Specific Reference Symbols)**

Parameter	Unit	Test 1	
Downlink power allocation	$\rho_A$	dB	0
	$\rho_B$	dB	0 (Note 1)
	$\sigma$	dB	-3
Cell-specific reference signals		Antenna ports 0,1	
CSI reference signals		Antenna ports 15,...,18	
Beamforming model		Annex B.4.3(Note 4, 5)	
CSI-RS periodicity and subframe offset $T_{\text{CSI-RS}} / \Delta_{\text{CSI-RS}}$	Subframes	5 / 2	
CSI reference signal configuration		3	
Zero-power CSI-RS configuration $l_{\text{CSI-RS}} /$ ZeroPowerCSI-RS bitmap	Subframes / bitmap	3 / 0001000000000000	
$N_{oc}$ at antenna port	dBm/15kHz	-98	
Symbols for unused PRBs		OCNG (Note 3)	
Number of allocated resource blocks (Note 2)	PRB	50	
Simultaneous transmission		No	
PDSCH transmission mode		9	
Precoding granularity		50	
PMI delay		8	
Reporting interval		1	
Reporting mode		PUSCH 3-1	
alternativeCodeBookEnabledFor4TX-r12		False	
CodeBookSubsetRestriction bitmap		0xFFFF000000000000	
Note 1: $P_B = 1$ . Note 2: 50 resource blocks are allocated in sub-frames 1,2,3,4,6,7,8,9 and 41 resource blocks (RB0–RB20 and RB30–RB49) are allocated in sub-frame 0. Note 3: These physical resource blocks are assigned to an arbitrary number of virtual UEs with one PDSCH per virtual UE; the data transmitted over the OCNG PDSCHs shall be uncorrelated pseudo random data, which is QPSK modulated. Note 4: The precoder in clause B.4.3 follows UE recommended PMI. Note 5: If the UE reports in an available uplink reporting instance at subframe SF#n based on PMI estimation at a downlink SF not later than SF#(n-4), this reported PMI cannot be applied at the eNB downlink before SF#(n+4).			

**Table 8.10.1.1.9A-2: Minimum performance for 4 Layer Spatial Multiplexing (User-Specific Reference Symbols)**

Test number	Bandwidth and MCS	Reference Channel	OCNG Pattern	Propagation Condition	Correlation Matrix and Antenna Configuration	Reference value		UE Category
						Fraction of Maximum Throughput (%)	SNR (dB)	
1	10 MHz 16QAM	R.75 FDD	OP.1 FDD	EPA5	4x4 Medium A Xpol	70	18.2	≥5

### 8.10.1.1.10 Closed loop spatial multiplexing performance - Single-Layer Spatial Multiplexing 2 Tx Antenna Port with CRS assistance information (Cell-Specific Reference Symbols)

The requirements are specified in Table 8.10.1.1.10-2, with the addition of parameters in Table 8.10.1.1.10-1. In Table 8.10.1.1.10-1, Cell 1 is the serving cell, and Cell 2 and Cell 3 are the aggressor cells. The downlink physical channel setup is according to Annex C.3.2 for each of Cell 1, Cell 2 and Cell 3, respectively. The CRS assistance information [7] is provided to the UE and includes information on Cell 2 and Cell 3.

The purpose of the test is to verify the closed loop single layer TM4 performance under assumption that UE applies CRS interference mitigation in the scenario with 2 CRS antenna ports in the serving and aggressor cells.

**Table 8.10.1.1.10-1: Test Parameters**

Parameter		Unit	Cell 1	Cell 2	Cell 3
Downlink power allocation	$\rho_A$	dB	-3	-3	-3
	$\rho_B$	dB	-3 (Note 1)	-3 (Note 1)	-3 (Note 1)
	$\sigma$	dB	0	0	0
$N_{oc}$ at antenna port		dBm/15kHz	-98	N/A	N/A
$\bar{E}_s/N_{oc}$		dB	Reference Value in Table 8.10.1.1.10-2	10.45	4.6
$BW_{channel}$		MHz	10	10	10
Cyclic prefix			Normal	Normal	Normal
Subframe Configuration			Non-MBSFN	Non-MBSFN	Non-MBSFN
Cell ID			0	1	6
Cell-specific reference signals			Antenna ports 0,1		
Number of control OFDM symbols (CFI)			2	2	2
PDSCH transmission mode			4	N/A	N/A
Precoding granularity		PRB	50	N/A	N/A
PMI delay (Note 2)		ms	8	N/A	N/A
Reporting interval		ms	1	N/A	N/A
Reporting mode			PUSCH 3-1	N/A	N/A
CodeBookSubsetRestriction bitmap			001111	N/A	N/A
Time Offset relative to Cell 1		$\mu$ s	N/A	3	-1
Frequency shift relative to Cell 1		Hz	N/A	300	-100
Interference model			N/A	As specified in clause B.5.3	As specified in clause B.5.3
Probability of occurrence of transmission in interference cells		%	N/A	20	20
Probability of occurrence of transmission rank in interfering cells	Rank 1	%	N/A	80	80
	Rank 2	%	N/A	20	20
Note 1: $P_B = 1$ .					
Note 2: If the UE reports in an available uplink reporting instance at subframe SF #n based on PMI estimation at a downlink SF not later than SF #(n-4), this reported PMI cannot be applied at the eNB downlink before SF #(n+4).					

**Table 8.10.1.1.10-2: Minimum Performance for PDSCH**

Test Number	Reference Channel	OCNG Pattern			Propagation Conditions (Note1)			Correlation Matrix and Antenna Configuration (Note 2)	Reference Value		UE Category
		Cell 1	Cell 2	Cell 3	Cell 1	Cell 2	Cell 3		Fraction of Maximum Throughput (%)	SNR (dB) (Note 3)	

1	R.35 FDD	OP.1 FDD	N/A	N/A	EVA5	EVA5	EVA5	2x4 low	70	11.1	≥2
Note 1: The propagation conditions for Cell 1, Cell 2 and Cell 3 are statistically independent. Note 2: The correlation matrix and antenna configuration apply for Cell 1, Cell 2 and Cell 3. Note 3: SNR corresponds to $\bar{E}_s/N_{oc}$ of cell 1.											

#### 8.10.1.1.11 Closed loop spatial multiplexing performance - Single-Layer Spatial Multiplexing 4 Tx Antenna Port with CRS assistance information (Cell-Specific Reference Symbols)

The requirements are specified in Table 8.10.1.1.11-2, with the addition of parameters in Table 8.10.1.1.11-1. In Table 8.10.1.1.11-1, Cell 1 is the serving cell, and Cell 2 is the aggressor cell. The downlink physical channel setup is according to Annex C.3.2 for each of Cell 1 and Cell 2, respectively. The CRS assistance information [7] is provided to the UE and includes information on Cell 2.

The purpose of the test is to verify the closed loop single layer TM4 performance under assumption that UE applies CRS interference mitigation in the scenario with 4 CRS antenna ports in the serving and aggressor cell.

**Table 8.10.1.1.11-1: Test Parameters**

Parameter		Unit	Cell 1	Cell 2
Downlink power allocation	$\rho_A$	dB	-6	-6
	$\rho_B$	dB	-6 (Note 1)	-6 (Note 1)
	$\sigma$	dB	3	3
$N_{oc}$ at antenna port		dBm/15k Hz	-98	N/A
$\bar{E}_s/N_{oc}$		dB	Reference Value in Table 8.10.1.1.11-2	10.45
BW <sub>Channel</sub>		MHz	10	10
Cyclic prefix			Normal	Normal
Subframe Configuration			Non-MBSFN	Non-MBSFN
Cell ID			0	1
Cell-specific reference signals			Antenna ports 0,1,2,3	
Number of control OFDM symbols (CFI)			2	2
PDSCH transmission mode			4	N/A
Precoding granularity		PRB	50	N/A
PMI delay (Note 2)		ms	8	N/A
Reporting interval		ms	1	N/A
Reporting mode			PUSCH 3-1	N/A
CodeBookSubsetRestriction bitmap			000000000000FFFF	N/A
Time Offset relative to Cell 1		μs	N/A	3
Frequency shift relative to Cell 1		Hz	N/A	300
Interference model			N/A	As specified in clause B.5.3
Probability of occurrence of transmission in interference cells		%	N/A	20
Probability of occurrence of transmission rank in interfering cells	Rank 1	%	N/A	80
	Rank 2	%	N/A	20
Note 1: $P_B = 1$ .				
Note 2: If the UE reports in an available uplink reporting instance at subframe SF #n based on PMI estimation at a downlink SF not later than SF #(n-4), this reported PMI cannot be applied at the eNB downlink before SF #(n+4).				

Table 8.10.1.1.11-2: Minimum Performance for PDSCH

Test Number	Reference Channel	OCNG Pattern		Propagation Conditions (Note1)		Correlation Matrix and Antenna Configuration (Note 2)	Reference Value		UE Category
		Cell 1	Cell 2	Cell 1	Cell 2		Fraction of Maximum Throughput (%)	SNR (dB) (Note 3)	
1	R.36-1 FDD	OP.1 FDD	N/A	EVA5	EVA5	4x4 low	70	9.3	≥2

Note 1: The propagation conditions for Cell 1 and Cell 2 are statistically independent.  
Note 2: The correlation matrix and antenna configuration apply for Cell 1 and Cell 2.  
Note 3: SNR corresponds to  $\bar{E}_s/N_{oc}$  of cell 1.

#### 8.10.1.1.12 Closed loop spatial multiplexing performance - Single-Layer Spatial Multiplexing with CRS assistance information (User-Specific Reference Symbols)

The requirements are specified in Table 8.10.1.1.12-2, with the addition of parameters in Table 8.10.1.1.12-1. In Table 8.10.1.1.12-1, Cell 1 is the serving cell, and Cell 2 and Cell 3 are the aggressor cells. The downlink physical channel setup is according to Annex C.3.2 for each of Cell 1, Cell 2 and Cell 3, respectively. The CRS assistance information [7] is provided to the UE and includes information on Cell 2 and Cell 3.

The purpose of the test is to verify the closed loop single layer TM9 performance under assumption that UE applies CRS interference mitigation in the scenario with 2 CRS antenna ports in the serving and aggressor cells.

Table 8.10.1.1.12-1: Test Parameters

Parameter	Unit	Cell 1	Cell 2	Cell 3	
Downlink power allocation	$\rho_A$	dB	0	0	0
	$\rho_B$	dB	0 (Note 1)	0 (Note 1)	0 (Note 1)
	$\sigma$	dB	-3	-3	-3



$N_{oc}$ at antenna port		dBm/15kHz	-98	N/A	N/A
$\bar{E}_s/N_{oc}$		dB	Reference Value in Table 8.10.1.1.12-2	10.45	4.6
$BW_{Channel}$		MHz	10	10	10
Cyclic prefix			Normal	Normal	Normal
Subframe Configuration			Non-MBSFN	Non-MBSFN	Non-MBSFN
Cell ID			0	1	6
Cell-specific reference signals			Antenna ports 0,1		
CSI reference signals			Antenna ports 15,16	N/A	N/A
CSI-RS periodicity and subframe offset $T_{CSI-RS} / \Delta_{CSI-RS}$	Subframes		5 / 2	N/A	N/A
CSI reference signal configuration			8	N/A	N/A
Zero-power CSI-RS configuration $I_{CSI-RS} / ZeroPowerCSI-RS$ bitmap	Subframes / bitmap		3 / 001000000000 0000	N/A	N/A
Number of control OFDM symbols (CFI)			2	2	2
PDSCH transmission mode			9	N/A	N/A
Precoding granularity		PRB	Frequency domain: 50 PRB Time domain: 1 ms	N/A	N/A
Beamforming model			Annex B.4.1		
Time Offset relative to Cell 1		$\mu$ s	N/A	3	-1
Frequency shift relative to Cell 1		Hz	N/A	300	-100
Interference model			N/A	As specified in clause B.5.4	As specified in clause B.5.4
Probability of occurrence of transmission in interference cells		%	N/A	20	20
Probability of occurrence of transmission rank in interfering cells	Rank 1	%	N/A	80	80
	Rank 2	%	N/A	20	20
Note 1: $P_B = 1$ .					

Table 8.10.1.1.12-2: Minimum Performance for PDSCH

Test Number	Reference Channel	OCNG Pattern			Propagation Conditions (Note1)			Correlation Matrix and Antenna Configuration (Note 2)	Reference Value		UE Category
		Cell 1	Cell 2	Cell 3	Cell 1	Cell 2	Cell 3		Fraction of Maximum Throughput (%)	SNR (dB) (Note 3)	
1	R.X FDD	OP.1 FDD	N/A	N/A	EVA5	EVA5	EVA5	2x4 low	70	12.3	$\geq 2$
Note 1: The propagation conditions for Cell 1, Cell 2 and Cell 3 are statistically independent.											
Note 2: The correlation matrix and antenna configuration apply for Cell 1, Cell 2 and Cell 3.											
Note 3: SNR corresponds to $\bar{E}_s/N_{oc}$ of cell 1.											

### 8.10.1.1.13 Performance requirements for DCI format 2D and non Quasi Co-located Antenna Ports

#### 8.10.1.1.13.1 Minimum requirements for QCL Type C and 3 Layers Spatial Multiplexing

The requirements are specified in Table 8.10.1.1.13.1-3, with the additional parameters in Table 8.10.1.1.13.1-1 and Table 8.10.1.1.13.1-2. The purpose of this test is to verify the UE capability of supporting non quasi-colocated antenna

ports when the UE receives DCI format 2D in a scenario with non-coherent joint transmission from two transmission points. The test verifies that the UE configured with quasi co-location type C performs correct tracking and compensation of the frequency and time difference between two transmission points, channel parameters estimation, channel estimation and rate matching behaviour according to the 'PDSCH RE Mapping and Quasi-Co-Location Indicator' signalling defined in [6]. In Table 8.10.1.1.13.1-1, transmission point 1 (TP 1) is the serving cell transmitting PDCCH, synchronization signals, PBCH and PDSCH, and transmission point 2 (TP 2) has different Cell ID and transmits PDSCH. In the test the PDSCH is transmitted from TP 1 and TP 2. The downlink physical channel setup for TP 1 is according to Annex C.3.2 and for TP 2 according to Annex C.3.2.

Table 8.10.1.1.13.1-1: Test Parameters

Parameter	Unit	TP 1	TP 2
Downlink power allocation	$\rho_A$	dB	0
	$\rho_B$	dB	0 (Note 1)
	$\sigma$	dB	-3
Beamforming model		Random beamforming (rank 2)	Random beamforming (rank 1)
Cell-specific reference signals		Antenna ports 0,1	Antenna ports 0,1
CSI reference signals 0		Antenna ports {15,16,17,18}	N/A
CSI-RS 0 periodicity and subframe offset $T_{\text{CSI-RS}} / \Delta_{\text{CSI-RS}}$	Subframes	5 / 2	
CSI reference signal 0 configuration		0	
CSI reference signals 1		N/A	Antenna ports {15,16,17,18}
CSI-RS 1 periodicity and subframe offset $T_{\text{CSI-RS}} / \Delta_{\text{CSI-RS}}$	Subframes		5 / 2
CSI reference signal 1 configuration			8
Zero-power CSI-RS 0 configuration $I_{\text{CSI-RS}} / \text{ZeroPower CSI-RS}$ bitmap	Subframes/bitmap	2/ 0010000000000000	N/A
Zero-power CSI-RS1 configuration $I_{\text{CSI-RS}} / \text{ZeroPower CSI-RS}$ bitmap	Subframes/bitmap	N/A	2/ 0010000000000000
$E_s / N_{oc}$	dB	SNR1	SNR2 = SNR1-3dB
$N_{oc}$ at antenna port	dBm/15kHz	-98	-98
$BW_{\text{Channel}}$	MHz	10	10
Cyclic Prefix		Normal	Normal
Cell ID		0	126
Number of control OFDM symbols / PDSCH start		2	2
Timing offset relative to TP 1	us	N/A	2
Frequency offset relative to TP 1	Hz	N/A	200
<i>qcl-Operation</i> , 'PDSCH RE Mapping and Quasi-Co-Location Indicator'		Type C, '00'	
PDSCH transmission mode (Note 2)		10	10
Number of allocated resource block		50	50
Note 1: $P_B = 1$			
Note 2: PDSCH transmission is done from both TPs (CW2 is transmitted from TP 1 and CW1 is transmitted from TP 2)			

**Table 8.10.1.1.13.1-2: Configurations of PQI and DL transmission hypothesis for each PQI set**

PQI set index	Parameters in each PQI set		DL transmission hypothesis for each PQI Set	
	NZP CSI-RS Index (For quasi co-location)	ZP CSI-RS configuration	TP 1	TP 2
PQI set 0	CSI-RS 0 for CW2 CSI-RS 1 for CW1	ZP CSI-RS 0	PDSCH	PDSCH

**Table 8.10.1.1.13.1-3: Performance Requirements**

Test Number	Reference Channel		OCNG Pattern		Propagation Conditions (Note1)		Correlation Matrix and Antenna Configuration (Note 2)	Reference Value		UE Category
	TP 1	TP 2	TP 1	TP 2	TP 1	TP 2		Fraction of Maximum Throughput (%)	SNR1 (dB) (Note 3)	
1	R.98 FDD	R.99 FDD	OP.1F DD	OP.1F DD	EPA5	EPA5	4x4 Low	70	11.0	≥2
Note 1: The propagation conditions for TP 1 and TP 2 are statistically independent. Note 2: Correlation matrix and antenna configuration parameters apply for each of TP 1 and TP 2. Note 3: SNR corresponds to $E_s/N_{oc}$ of TP 1 and TP 2 as defined in clause 8.1.1.										

#### 8.10.1.1.13.2 Minimum requirements for QCL Type C and 4 Layers Spatial Multiplexing

The requirements are specified in Table 8.10.1.1.13.2-3, with the additional parameters in Table 8.10.1.1.13.2-1 and Table 8.10.1.1.13.2-2. The purpose of this test is to verify the UE capability of supporting non quasi-colocated antenna ports when the UE receives DCI format 2D in a scenario with non-coherent joint transmission from two transmission points. The test verifies that the UE configured with quasi co-location type C performs correct tracking and compensation of the frequency and time difference between two transmission points, channel parameters estimation, channel estimation and rate matching behaviour according to the 'PDSCH RE Mapping and Quasi-Co-Location Indicator' signalling defined in [6]. In Table 8.10.1.1.13.2-1, transmission point 1 (TP 1) is the serving cell transmitting PDCCH, synchronization signals, PBCH and PDSCH, and transmission point 2 (TP 2) has different Cell ID and transmits PDSCH. In the test the PDSCH is transmitted from TP 1 and TP 2. The downlink physical channel setup for TP 1 is according to Annex C.3.2 and for TP 2 according to Annex C.3.2.

Table 8.10.1.1.13.2-1: Test Parameters

Parameter	Unit	TP 1	TP 2
Downlink power allocation	$\rho_A$	dB	0
	$\rho_B$	dB	0 (Note 1)
	$\sigma$	dB	-3
Beamforming model		Random beamforming (rank 2)	Random beamforming (rank 2)
Cell-specific reference signals		Antenna ports 0,1,2,3	Antenna ports 0,1,2,3
CSI reference signals 0		Antenna ports {15,16,17,18}	N/A
CSI-RS 0 periodicity and subframe offset $T_{\text{CSI-RS}} / \Delta_{\text{CSI-RS}}$	Subframes	5 / 2	
CSI reference signal 0 configuration		0	
CSI reference signals 1		N/A	Antenna ports {15,16,17,18}
CSI-RS 1 periodicity and subframe offset $T_{\text{CSI-RS}} / \Delta_{\text{CSI-RS}}$	Subframes		5 / 2
CSI reference signal 1 configuration			8
Zero-power CSI-RS 0 configuration $I_{\text{CSI-RS}} / \text{ZeroPower CSI-RS}$ bitmap	Subframes/bitmap	2/ 0010000000000000	N/A
Zero-power CSI-RS1 configuration $I_{\text{CSI-RS}} / \text{ZeroPower CSI-RS}$ bitmap	Subframes/bitmap	N/A	2/ 0010000000000000
$E_s / N_{oc}$	dB	SNR1	SNR2 = SNR1
$N_{oc}$ at antenna port	dBm/15kHz	-98	-98
$BW_{\text{Channel}}$	MHz	10	10
Cyclic Prefix		Normal	Normal
Cell ID		0	126
Number of control OFDM symbols / PDSCH start		2	2
Timing offset relative to TP 1	us	N/A	2
Frequency offset relative to TP 1	Hz	N/A	200
<i>qcl-Operation</i> , 'PDSCH RE Mapping and Quasi-Co-Location Indicator'		Type C, '00'	
PDSCH transmission mode (Note 2)		10	10
Number of allocated resource block		50	50
Note 1: $P_B = 1$			
Note 2: PDSCH transmission is done from both TPs (CW1 is transmitted from TP 1 and CW2 is transmitted from TP 2)			

Table 8.10.1.1.13.2-2: Configurations of PQI and DL transmission hypothesis for each PQI set

PQI set index	Parameters in each PQI set		DL transmission hypothesis for each PQI Set	
	NZP CSI-RS Index (For quasi co-location)	ZP CSI-RS configuration	TP 1	TP 2
PQI set 0	CSI-RS 0 for CW1 CSI-RS 1 for CW2	ZP CSI-RS 0	PDSCH	PDSCH

Table 8.10.1.1.13.2-3: Performance Requirements

Test Number	Reference Channel		OCNG Pattern		Propagation Conditions (Note1)		Correlation Matrix and Antenna Configuration (Note 2)	Reference Value		UE Category
	TP 1	TP 2	TP 1	TP 2	TP 1	TP 2		Fraction of Maximum Throughput (%)	SNR1 (dB) (Note 3)	
1	R.10 0 FDD	R.10 0 FDD	OP.1F DD	OP.1F DD	EPA5	EPA5	4x4 Low	70	14.8	≥2
Note 1: The propagation conditions for TP 1 and TP 2 are statistically independent. Note 2: Correlation matrix and antenna configuration parameters apply for each of TP 1 and TP 2. Note 3: SNR corresponds to $E_s/N_{oc}$ of TP 1 and TP 2 as defined in clause 8.1.1.										

## 8.10.1.1.14 HST-SFN performance

## 8.10.1.1.14.1 Minimum Requirement for Rel-16 further enhanced HST

The requirements are specified in Table 8.10.1.1.14.1-2, with the addition of the parameters in Table 8.10.1.1.14.1-1 and the downlink physical channel setup according to Annex C.3.2. The purpose of this test is to verify UE performance in the HST-SFN-500 scenario. The test for HST-SFN-500 scenario defined in B.3B is applied when *highSpeedEnhDemodFlag2-r16* [7] is received.

Table 8.10.1.1.14.1-1: Test Parameters for UE performance in HST-SFN-500 scenario (FRC)

Parameter	Unit	Test 1	
Downlink power allocation	$\rho_A$	dB	-3
	$\rho_B$	dB	-3 (NOTE 1)
	$\sigma$	dB	0
$N_{oc}$ at antenna port		dBm/15kHz	-98
PDSCH transmission mode			3
NOTE 1: $P_B = 1$ .			

Table 8.10.1.1.14.1-2: Minimum performance UE in HST-SFN-500 scenario (FRC)

Test number	Bandwidth	Reference Channel	OCNG Pattern	Propagation Condition	Correlation Matrix and Antenna Configuration	Reference value		UE Category
						Fraction of Maximum Throughput (%)	SNR (dB)	
1 <sup>NOTE 2</sup>	10 MHz	R.87-1 FDD	OP.1 FDD	HST-SFN-500	2x4	70	6.8	≥ 1
NOTE 1: Test case applicability is defined in 8.1.2.6. NOTE 2: The requirement defined is based on the normalized channel model, i.e. the power of each tap is normalized to the instantaneous total received power from four taps.								

## 8.10.1.2 TDD (Fixed Reference Channel)

The parameters specified in Table 8.10.1.2-1 are valid for all TDD tests unless otherwise stated.

**Table 8.10.1.2-1: Common Test Parameters (TDD)**

Parameter	Unit	Value
Uplink downlink configuration (Note 1)		1
Special subframe configuration (Note 2)		4
Cyclic prefix		Normal
Cell ID		0
Inter-TTI Distance		1
Number of HARQ processes per component carrier	Processes	7
Maximum number of HARQ transmission		4
Redundancy version coding sequence		{0,1,2,3} for QPSK and 16QAM {0,0,1,2} for 64QAM, 256QAM and 1024QAM
Number of OFDM symbols for PDCCH	OFDM symbols	4 for 1.4 MHz bandwidth, 3 for 3 MHz and 5 MHz bandwidths, 2 for 10 MHz, 15 MHz and 20 MHz bandwidths unless otherwise stated
Cross carrier scheduling		Not configured
Precoder update granularity		Frequency domain: 1 PRG for Transmission modes 9 and 10 Time domain: 1 ms
ACK/NACK feedback mode		Multiplexing
Note 1: as specified in Table 4.2-2 in TS 36.211 [4].		
Note 2: as specified in Table 4.2-1 in TS 36.211 [4].		

#### 8.10.1.2.1 Transmit diversity performance with 2Tx Antenna Ports (Cell-Specific Reference Symbols)

The requirements are specified in Table 8.10.1.2.1-2, with the addition of the parameters in Table 8.10.1.2.1-1 and the downlink physical channel setup according to Annex C.3.2. The purpose is to verify the performance of transmit diversity (SFBC) with 2 transmitter antennas.

**Table 8.10.1.2.1-1: Test Parameters for Transmit diversity Performance (FRC) with 4Rx Antenna Ports**

Parameter	Unit	Test 1	
Downlink power allocation	$\rho_A$	dB	-3
	$\rho_B$	dB	-3 (Note 1)
	$\sigma$	dB	0
$N_{oc}$ at antenna port		dBm/15kHz	-98
PDSCH transmission mode			2
Note 1: $P_B = 1$			

Table 8.10.1.2.1-2: Minimum performance Transmit Diversity (FRC) with 4Rx Antenna Ports

Test number	Bandwidth and MCS	Reference Channel	OCNG Pattern	Propagation Condition	Correlation Matrix and Antenna Configuration	Reference value		UE Category
						Fraction of Maximum Throughput (%)	SNR (dB)	
1	10 MHz 16QAM 1/2	R.11 TDD	OP.1 TDD	EVA5	2x4 Medium correlation A, ULA	70	3.9	≥2

#### 8.10.1.2.1A Transmit diversity performance with Enhanced Performance Requirement Type A – 2 Tx Antenna Ports with TM3 interference model

The requirements are specified in Table 8.10.1.2.1A-2, with the addition of parameters in Table 8.10.1.2.1A-1 and the downlink physical channel setup according to Annex C.3.2. The purpose is to verify the performance of transmit diversity (SFBC) with 2 transmit antennas when the PDSCH transmission in the serving cell is interfered by PDSCH of one dominant interfering cells applying transmission mode 3 interference model defined in clause B.5.2. In Table 8.10.1.2.1A-1, Cell 1 is the serving cell, and Cell 2, 3 are interfering cells. The downlink physical channel setup is according to Annex C.3.2 for each of Cell 1, Cell 2 and Cell 3, respectively.

Table 8.10.1.2.1A-1: Test Parameters for Transmit diversity Performance (FRC) with TM3 interference model

Parameter		Unit	Cell 1	Cell 2
Downlink power allocation	$\rho_A$	dB	-3	-3
	$\rho_B$	dB	-3 (Note 1)	-3
	$\sigma$	dB	0	0
Cell-specific reference signals			Antenna ports 0,1	Antenna ports 0,1
$N_{oc}$ at antenna port		dBm/15kHz	-98	N/A
DIP (Note 2)		dB	N/A	-1.73
BW <sub>Channel</sub>		MHz	10	10
Cyclic Prefix			Normal	Normal
Cell Id			0	1
Number of control OFDM symbols			2	2
PDSCH transmission mode			2	N/A
Interference model			N/A	As specified in clause B.5.2
Probability of occurrence of transmission rank in interfering cells	Rank 1	%	N/A	80
	Rank 2	%	N/A	20
Reporting interval		ms	5	N/A
Reporting mode			PUCCH 1-0	N/A
ACK/NACK feedback mode			Multiplexing	N/A
Physical channel for CQI reporting			PUSCH(Note 5)	N/A
cqi-pmi-ConfigurationIndex			4	N/A
Note 1: $P_B = 1$				
Note 2: The respective received power spectral density of each interfering cell relative to $N_{oc}$ is defined by its associated DIP value as specified in clause B.5.1.				
Note 3: Cell 1 is the serving cell. Cell 2 is the interfering cell.				
Note 4: The cells are time-synchronous.				
Note 5: To avoid collisions between CQI reports and HARQ-ACK it is necessary to report both on PUSCH instead of PUCCH. PDCCH DCI format 0 shall be transmitted in downlink SF#4 and #9 to allow periodic CQI to multiplex with the HARQ-ACK on PUSCH in uplink subframe SF#8 and #3.				

**Table 8.10.1.2.1A-2: Enhanced Performance Requirement Type A, Transmit Diversity (FRC) with TM3 interference model**

Test Number	Reference Channel		OCNG Pattern		Propagation Conditions		Correlation Matrix and Antenna Configuration (Note 3)	Reference Value		UE Category
			Cell 1	Cell 2	Cell 1	Cell 2		Fraction of Maximum Throughput (%)	SINR (dB) (Note 2)	
1	R.46 TDD	OP.1 TDD	N/A	EVA70	EVA70	2x4 Low	70	-4.9	≥1	
Note 1: The propagation conditions for Cell 1 and Cell 2 are statistically independent. Note 2: SINR corresponds to $E_s/N_{oc}$ of Cell 1 as defined in clause 8.1.1. Note 3: Correlation matrix and antenna configuration parameters apply for each of Cell 1 and Cell 2.										

**8.10.1.2.2 Open-loop spatial multiplexing performance with 2Tx Antenna Ports (Cell-Specific Reference Symbols)**

The requirements are specified in Table 8.10.1.2.2-2, with the addition of the parameters in Table 8.10.1.2.2-1 and the downlink physical channel setup according to Annex C.3.2.

**Table 8.10.1.2.2-1: Test Parameters for Large Delay CDD (FRC) with 4Rx Antenna Ports**

Parameter	Unit	Test 1
Downlink power allocation	$\rho_A$	dB
	$\rho_B$	dB
	$\sigma$	dB
$N_{oc}$ at antenna port	dBm/15kHz	-98
ACK/NACK feedback mode		Bundling
PDSCH transmission mode		3

Note 1:  $P_B = 1$

**Table 8.10.1.2.2-2: Minimum performance Large Delay CDD (FRC) with 4Rx Antenna Ports**

Test number	Bandwidth and MCS	Reference Channel	OCNG Pattern	Propagation Condition	Correlation Matrix and Antenna Configuration	Reference value		UE Category
						Fraction of Maximum Throughput (%)	SNR (dB)	
1	10 MHz 16QAM 1/2	R.11-1 TDD	OP.1 TDD	EVA70	2x4 Low	70	7.7	≥2

**8.10.1.2.3 Closed-loop spatial multiplexing Enhanced Performance Requirements Type A - Single-Layer Spatial Multiplexing 2 Tx Antenna Port with TM4 interference model (Cell-Specific Reference Symbols)**

The requirements are specified in Table 8.10.1.2.3-2, with the addition of the parameters in Table 8.10.1.2.3-1 and the downlink physical channel setup according to Annex C.3.2. The purpose of these tests is to verify the closed loop rank-one performance with wideband precoding with two transmit antennas when the PDSCH transmission in the serving cell is interfered by PDSCH of one dominant interfering cell applying transmission mode 4 interference model defined in clause B.5.3. In Table 8.10.1.2.3-1, Cell 1 is the serving cell, and Cell 2 is the interfering cells. The downlink physical channel setup is according to Annex C.3.2 for each of Cell 1 and Cell 2, respectively.



**Table 8.10.1.2.3-1: Test Parameters for Single-Layer Spatial Multiplexing (FRC) with TM4 interference model and 4Rx Antenna Ports**

Parameter		Unit	Cell 1	Cell 2
Downlink power allocation	$\rho_A$	dB	-3	-3
	$\rho_B$	dB	-3 (Note 1)	-3
	$\sigma$	dB	0	0
Cell-specific reference signals			Antenna ports 0,1	Antenna ports 0,1
$N_{oc}$ at antenna port		dBm/15kHz	-98	N/A
DIP (Note 2)		dB	N/A	-1.73
BW <sub>Channel</sub>		MHz	10	10
Cell Id			0	1
PDSCH transmission mode			6	N/A
Interference model			N/A	As specified in clause B.5.3
Probability of occurrence of transmission rank in interfering cells	Rank 1	%	N/A	80
	Rank 2	%	N/A	20
Precoding granularity		PRB	50	6
PMI delay (Note 4)		ms	10 or 11	N/A
Reporting interval		ms	5	N/A
Reporting mode			PUCCH 1-1	N/A
CodeBookSubsetRestriction bitmap			1111	N/A
Note 1: $P_B = 1$				
Note 2: The respective received power spectral density of each interfering cell relative to $N_{oc}$ is defined by its associated DIP value as specified in clause B.5.1.				
Note 3: Cell 1 is the serving cell. Cell 2, 3 are the interfering cells.				
Note 4: If the UE reports in an available uplink reporting instance at subframe SF#n based on PMI estimation at a downlink SF not later than SF#(n-4), this reported PMI cannot be applied at the eNB downlink before SF#(n+4).				
Note 5: All cells are time-synchronous.				

**Table 8.10.1.2.3-2: Enhanced Performance Requirement Type A, Single-Layer Spatial Multiplexing (FRC) with TM4 interference model and 4Rx Antenna Ports**

Test Number	Reference Channel and MCS	OCNG Pattern		Propagation Conditions		Correlation Matrix and Antenna Configuration (Note 3)	Reference Value		UE Category
		Cell 1	Cell 2	Cell 1	Cell 2		Fraction of Maximum Throughput (%)	SINR (dB) (Note 2)	
1	R.47 TDD 16QAM	OP.1 TDD	N/A	EVA5	EVA5	2x4 Low	70	-1.9	≥1
Note 1: The propagation conditions for Cell 1 and Cell 2 are statistically independent.									
Note 2: SINR corresponds to $E_s/N_{oc}$ of Cell 1 as defined in clause 8.1.1.									
Note 3: Correlation matrix and antenna configuration parameters apply for each of Cell 1 and Cell 2.									

#### 8.10.1.2.4 Closed-loop spatial multiplexing performance, Dual-Layer Spatial Multiplexing 4 Tx Antenna Ports (Cell-Specific Reference Symbols)

The requirements are specified in Table 8.10.1.2.4-2, with the addition of the parameters in Table 8.10.1.2.4-1 and the downlink physical channel setup according to Annex C.3.2.

**Table 8.10.1.2.4-1: Test Parameters for Dual-Layer Spatial Multiplexing (FRC) with 4Rx Antenna Ports**

Parameter	Unit	Test 1-2	Test 3
Downlink power allocation	$\rho_A$	dB	-6
	$\rho_B$	dB	-6 (Note 1)
	$\sigma$	dB	3
$N_{oc}$ at antenna port	dBm/15kHz	-98	-98
Precoding granularity	PRB	6	6
PMI delay (Note 2)	ms	10 or 11	10 or 11
Reporting interval	ms	1 or 4 (Note 3)	1 or 4 (Note 3)
Reporting mode		PUSCH 1-2	PUSCH 3-1
ACK/NACK feedback mode		Bundling	Bundling
CodeBookSubsetRestriction bitmap		00000000000000000000000000000000 00001111111111111111111100000000 00000000	00000000000000000000000000000000 00001111111111111111111100000000 00000000
PDSCH transmission mode		4	4
Note 1: $P_B = 1$ .			
Note 2: If the UE reports in an available uplink reporting instance at subframe SF#n based on PMI estimation at a downlink SF not later than SF#(n-4), this reported PMI cannot be applied at the eNB downlink before SF#(n+4)			
Note 3: For Uplink - downlink configuration 1 the reporting interval will alternate between 1ms and 4ms.			

**Table 8.10.1.2.4-2: Minimum performance Dual-Layer Spatial Multiplexing (FRC) with 4Rx Antenna Ports**

	Bandwidth and MCS	Reference Channel	OCNG Pattern	Propagation Condition	Correlation Matrix and Antenna Configuration	Reference value		UE Category	DL UE category
						Fraction of Maximum Throughput (%)	SNR (dB)		
1	10 MHz 64 QAM	R.36 TDD	OP.1 TDD	EPA5	4x4 Low	70	10.4	≥2	≥6
2	10 MHz 256QAM	R.72 TDD	OP.1 TDD	EPA5	4x4 Low	70	17.5	11-12	≥11
3	10MHz 1024QAM	R.102 TDD	OP.1 TDD	EPA5	4x4 Low	70	28.6	TBD	20, ≥ 21

#### 8.10.1.2.4A Enhanced Performance Requirement Type C - Dual-Layer Spatial Multiplexing with 2Tx Antenna Ports

The requirements are specified in Table 8.10.1.2.4A-2, with the addition of the parameters in Table 8.10.1.2.4A-1 and the downlink physical channel setup according to Annex C.3.2. The purpose of these tests is to verify the closed loop rank-two performance with wideband precoding.

**Table 8.10.1.2.4A-1: Test Parameters for Dual-Layer Spatial Multiplexing (FRC)**

Parameter	Unit	Test 1	
Downlink power allocation	$\rho_A$	dB	-3
	$\rho_B$	dB	-3 (Note 1)
	$\sigma$	dB	0
$N_{oc}$ at antenna port	dBm/15kHz	-98	
Precoding granularity	PRB	50	
PMI delay (Note 2)	ms	10 or 11	
Reporting interval	ms	1 or 4 (Note 3)	
Reporting mode		PUSCH 3-1	
ACK/NACK feedback mode		Bundling	
CodeBookSubsetRestriction bitmap		110000	
PDSCH transmission mode		4	

Note 1: $P_B = 1$ .
Note 2: If the UE reports in an available uplink reporting instance at subframe SF#n based on PMI estimation at a downlink SF not later than SF#(n-4), this reported PMI cannot be applied at the eNB downlink before SF#(n+4).
Note 3: For Uplink - downlink configuration 1 the reporting interval will alternate between 1ms and 4ms.

**Table 8.10.1.2.4A-2: Enhanced Performance Requirement Type C for Dual-Layer Spatial Multiplexing (FRC)**

Test number	Bandwidth	Reference Channel	OCNG Pattern	Propagation Condition	Correlation Matrix and Antenna Configuration	Reference value		UE Category
						Fraction of Maximum Throughput (%)	SNR (dB)	
1	10 MHz	R.11-1 TDD	OP.1 TDD	ETU70	2x4 Medium	70	16.9	$\geq 2$

#### 8.10.1.2.5 Enhanced Performance Requirement Type A – Single-layer Spatial Multiplexing with TM9 interference model (User-Specific Reference Symbols)

The requirements are specified in Table 8.10.1.2.5-2, with the addition of the parameters in Table 8.10.1.2.5-1 and the downlink physical channel setup according to Annex C.3.2. The purpose of these tests is to verify closed-loop rank one performance on one of the antenna ports 7 or 8 without a simultaneous transmission on the other antenna port in the serving cell when the PDSCH transmission in the serving cell is interfered by PDSCH of one dominant interfering cell applying transmission mode 9 interference model defined in clause B.5.4. In 8.10.1.2.5-1, Cell 1 is the serving cell, and Cell 2 is the interfering cell. The downlink physical channel setup is according to Annex C.3.2 for each of Cell 1 and Cell 2, respectively.

**Table 8.10.1.2.5-1: Test Parameters for Testing CDM-multiplexed DM RS (single layer) with TM9 interference model and 4Rx Antenna Ports**

parameter		Unit	Cell 1	Cell 2
Downlink power allocation	$\rho_A$	dB	0	0
	$\rho_B$	dB	0 (Note 1)	0
	$\sigma$	dB	-3	-3
Cell-specific reference signals			Antenna ports 0,1	Antenna ports 0,1
CSI reference signals			Antenna ports 15,16	N/A
CSI-RS periodicity and subframe offset $T_{\text{CSI-RS}} / \Delta_{\text{CSI-RS}}$		Subframes	5 / 4	N/A
CSI reference signal configuration			0	N/A
$N_{oc}$ at antenna port		dBm/15kHz	-98	N/A
DIP (Note 2)		dB	N/A	-1.73
$BW_{\text{Channel}}$		MHz	10	10
Cell Id			0	126
PDSCH transmission mode			9	9
Beamforming model			As specified in clause B.4.3 (Note 4, 5)	N/A
Interference model			N/A	As specified in clause B.5.4
Probability of occurrence of transmission rank in interfering cells	Rank 1		N/A	70
	Rank 2		N/A	30
Precoder update granularity		PRB	50	6
PMI delay (Note 5)		ms	10 or 11	N/A
Reporting interval		ms	5	N/A
Reporting mode			PUCCH 1-1	N/A
CodeBookSubsetRestriction bitmap			001111	N/A
Symbols for unused PRBs			OCNG (Note 6)	N/A
Simultaneous transmission			No simultaneous transmission on the other antenna port in (7 or 8) not used for the input signal under test	N/A
Physical channel for CQI reporting			PUSCH(Note 8)	N/A
cqi-pmi-ConfigurationIndex			4	N/A

Note 1:	$P_B = 1$
Note 2:	The respective received power spectral density of each interfering cell relative to $N_{oc}$ is defined by its associated DIP value as specified in clause B.5.1.
Note 3:	The modulation symbols of the signal under test in Cell 1 are mapped onto antenna port 7 or 8.
Note 4:	The precoder in clause B.4.3 follows UE recommended PMI.
Note 5:	If the UE reports in an available uplink reporting instance at subframe SF#n based on PMI estimation at a downlink SF not later than SF#(n-4), this reported PMI cannot be applied at the eNB downlink before SF#(n+4).
Note 6:	These physical resource blocks are assigned to an arbitrary number of virtual UEs with one PDSCH per virtual UE; the data transmitted over the OCNG PDSCHs shall be uncorrelated pseudo random data, which is QPSK modulated.
Note 7:	All cells are time-synchronous.
Note 8:	To avoid collisions between CQI reports and HARQ-ACK it is necessary to report both on PUSCH instead of PUCCH. PDCCH DCI format 0 shall be transmitted in downlink SF#4 and #9 to allow periodic CQI to multiplex with the HARQ-ACK on PUSCH in uplink subframe SF#8 and #3.

**Table 8.10.1.2.5-2: Enhanced Performance Requirement Type A, CDM-multiplexed DM RS with TM9 interference model and 4Rx Antenna Ports**

Test Number	Reference Channel and MCS	OCNG Pattern		Propagation Conditions		Correlation Matrix and Antenna Configuration (Note 3)	Reference Value		UE Category
		Cell 1	Cell 2	Cell 1	Cell 2		Fraction of Maximum Throughput (%)	SINR (dB) (Note 2)	
1	R.76 TDD QPSK	OP.1 TDD	N/A	EVA5	EVA5	2x4 Low	70	-3.3	≥1
Note 1: The propagation conditions for Cell 1 and Cell 2 are statistically independent.									
Note 2: SINR corresponds to $E_s/N_{oc}$ of Cell 1 as defined in clause 8.1.1.									
Note 3: Correlation matrix and antenna configuration parameters apply for each of Cell 1 and Cell 2.									

#### 8.10.1.2.5A Single-layer Spatial Multiplexing (with multiple CSI-RS configurations)

The requirements are specified in Table 8.10.1.2.5A-2, with the addition of the parameters in Table 8.10.1.2.5A-1 and the downlink physical channel setup according to Annex C.3.2. The purpose of these tests is to verify closed loop rank one performance on one of the antenna ports 7 or 8 with a simultaneous transmission on the other antenna port in the serving cell, and to verify rate matching with multiple CSI reference symbol configurations with non-zero and zero transmission power.

**Table 8.10.1.2.5A-1: Test Parameters for Testing CDM-multiplexed DM RS (single layer) with multiple CSI-RS configurations**

Parameter	Unit	Test 1	
Downlink power allocation	$\rho_A$	dB	0
	$\rho_B$	dB	0 (Note 1)
	$\sigma$	dB	-3

Cell-specific reference signals		Antenna ports 0,1
CSI reference signals		Antenna ports 15,...,18
Beamforming model		Annex B.4.1
CSI-RS periodicity and subframe offset $T_{CSI-RS} / \Delta_{CSI-RS}$	Subframes	5 / 4
CSI reference signal configuration		3
Zero-power CSI-RS configuration $I_{CSI-RS} /$ ZeroPowerCSI-RS bitmap	Subframes / bitmap	4 / 0010000000000000
$N_{oc}$ at antenna port	dBm/15kHz	-98
Symbols for unused PRBs		OCNG (Note 4)
Number of allocated resource blocks (Note 2)	PRB	50
Simultaneous transmission		Yes (Note 3, 5)
PDSCH transmission mode		9
Number of MBSFN subframes	Subframes	NA
<p>Note 1: <math>P_B = 1</math>.</p> <p>Note 2: The modulation symbols of the signal under test are mapped onto antenna port 7 or 8.</p> <p>Note 3: Modulation symbols of an interference signal is mapped onto the antenna port (7 or 8) not used for the input signal under test.</p> <p>Note 4: These physical resource blocks are assigned to an arbitrary number of virtual UEs with one PDSCH per virtual UE; the data transmitted over the OCNG PDSCHs shall be uncorrelated pseudo random data, which is QPSK modulated.</p> <p>Note 5: The two UEs' scrambling identities <math>n_{SCID}</math> are set to 0 for CDM-multiplexed DM RS with interfering simultaneous transmission test cases.</p>		

**Table 8.10.1.2.5A-2: Minimum performance for CDM-multiplexed DM RS with interfering simultaneous transmission (FRC) with multiple CSI-RS configurations**

Test number	Bandwidth and MCS	Reference Channel	OCNG Pattern	Propagation Condition	Correlation Matrix and Antenna Configuration	Reference value		UE Category
						Fraction of Maximum Throughput (%)	SNR (dB)	
1	10 MHz 64QAM 1/2	R.44 TDD	OP.1 TDD	EPA5	2x4 Low	70	15.8	$\geq 2$

Note 1: The reference channel applies to both the input signal under test and the interfering signal.

**Table 8.10.1.2.5A-3: Void**

#### 8.10.1.2.5B Single-layer Spatial Multiplexing (With Enhanced DMRS table configured)

For single-layer transmission on antenna port 7, 8, 11 or 13 upon detection of a PDCCH with DCI format 2C, the requirement is specified in Table 8.10.1.2.5B -2, with the addition of the parameters in Table 8.10.1.2.5B -1 and the downlink physical channel setup according to Annex C.3.2. The purpose of the test is to verify rank-1 performance on antenna port 11 with a simultaneous transmission on the antenna port 7, 8 or 13 with DMRS enhancement table and 4 orthogonal DMRS ports (dmrs-Enhancements-r13 UE-EUTRA-Capability [7]).

**Table 8.10.1.2.5B-1: Test Parameters for Testing CDM-multiplexed DM RS (single layer) with interfering simultaneous transmission (FRC) with multiple CSI-RS configurations with Enhanced DMRS table**

Parameter		Unit	Test 1
Downlink power allocation	$\rho_A$	dB	0
	$\rho_B$	dB	0 (Note 1)
	$\sigma$	dB	-3
Beamforming model			Annex B.4.1A
Cell-specific reference signals			Antenna ports 0,1
CSI reference signals			Antenna ports 15,...,18
CSI-RS periodicity and subframe offset $T_{\text{CSI-RS}} / \Delta_{\text{CSI-RS}}$	Subframes		5 / 4
CSI reference signal configuration			3
Zero-power CSI-RS configuration $l_{\text{CSI-RS}} / \text{ZeroPowerCSI-RS}$ bitmap	Subframes / bitmap		4 / 0010000000000000
$N_{oc}$ at antenna port		dBm/15kHz	-98
Symbols for unused PRBs			OCNG (Note 4)
Number of allocated resource blocks (Note 2)		PRB	50
Simultaneous transmission			Yes (Note 3, 5)
dms-Enhancements-r13			Enable
PDSCH transmission mode			9
Note 1: $P_B = 1$ . Note 2: The modulation symbols of the signal under test are mapped onto antenna port 11. Note 3: Modulation symbols of an interference signal are random mapped onto one antenna port among antenna port 7, 8 and 13. The update granularity for randomized mapping antenna port is 1 PRG in frequency domain and 1ms in time domain. Note 4: These physical resource blocks are assigned to an arbitrary number of virtual UEs with one PDSCH per virtual UE; the data transmitted over the OCNG PDSCHs shall be uncorrelated pseudo random data, which is QPSK modulated. Note 5: The two UEs' scrambling identities $n_{\text{SCID}}$ are set to 0 with OCC =4.			

**Table 8.10.1.2.5B-2: Minimum performance for CDM-multiplexed DM RS with interfering simultaneous transmission (FRC) with multiple CSI-RS configurations with Enhanced DMRS table**

Test number	Bandwidth and MCS	Reference Channel	OCNG Pattern	Propagation Condition	Correlation Matrix and Antenna Configuration	Reference value		UE Category
						Fraction of Maximum Throughput (%)	SNR (dB)	
1	10 MHz 64QAM 1/2	R.44 TDD	OP.1 TDD	EPA5	2x4 Low	70	15.8	≥2
Note 1: The reference channel applies to both the input signal under test and the interfering signal.								

#### 8.10.1.2.6 Dual-Layer Spatial Multiplexing (User-Specific Reference Symbols)

For dual-layer transmission on antenna ports 7 and 8 upon detection of a PDCCH with DCI format 2C, the requirements are specified in Table 8.10.1.2.6-2, with the addition of the parameters in Table 8.10.1.2.6-1 where Cell 1 is the serving



cell and Cell 2 is the interfering cell. The downlink physical channel setup is set according to Annex C.3.2. The purpose of these tests is to verify the rank-2 performance for full RB allocation, to verify rate matching with multiple CSI reference symbol configurations with non-zero and zero transmission power, and to verify that the UE correctly estimate SNR.

**Table 8.10.1.2.6-1: Test Parameters for Testing CDM-multiplexed DM RS (dual layer) with multiple CSI-RS configurations and 4Rx Antenna Ports**

Parameter		Unit	Test 1	
			Cell 1	Cell 2
Downlink power allocation	$\rho_A$	dB	0	0
	$\rho_B$	dB	0 (Note 1)	0
	$\sigma$	dB	-3	-3
	PDSCH_RA	dB	4	NA
	PDSCH_RB	dB	4	NA
Cell-specific reference signals			Antenna ports 0 and 1	Antenna ports 0 and 1
Cell ID			0	126
CSI reference signals			Antenna ports 15,16	NA
Beamforming model			Annex B.4.2	NA
CSI-RS periodicity and subframe offset $T_{\text{CSI-RS}} / \Delta_{\text{CSI-RS}}$		Subframes	5 / 4	NA
CSI reference signal configuration			8	NA
Zero-power CSI-RS configuration $I_{\text{CSI-RS}} / \text{ZeroPowerCSI-RS}$ bitmap		Subframes / bitmap	4 / 0010000000000000	NA
$N_{oc}$ at antenna port		dBm/15kHz	-98	NA
$E_s / N_{oc}$			Reference Value in Table 8.10.1.2.6-2	7.25dB
Symbols for unused PRBs			OCNG (Note 2)	NA
Number of allocated resource blocks (Note 2)		PRB	50	NA
Simultaneous transmission			No	NA
PDSCH transmission mode			9	Blanked
Note 1: $P_B = 1$ Note 2: These physical resource blocks are assigned to an arbitrary number of virtual UEs with one PDSCH per virtual UE; the data transmitted over the OCNG PDSCHs shall be uncorrelated pseudo random data, which is QPSK modulated.				

**Table 8.10.1.2.6-2: Minimum performance for CDM-multiplexed DM RS (FRC) with multiple CSI-RS configurations**

Test number	Bandwidth and MCS	Reference Channel	OCNG Pattern		Propagation Condition		Correlation Matrix and Antenna Configuration	Reference value		UE Category
			Cell 1	Cell 2	Cell 1	Cell 2		Fraction of Maximum Throughput (%)	SNR (dB)	
1	10 MHz 16QAM 1/2	R.51 TDD	OP.1 TDD	N/A	ETU5	ETU5	2x4 Low	70	9.5	≥2

Note 1: The propagation conditions for Cell 1 and Cell 2 are statistically independent.  
Note 2: Correlation matrix and antenna configuration parameters apply for each of Cell 1 and Cell 2.  
Note 3: SNR corresponds to  $\bar{E}_s/N_{oc}$  of Cell 1.

**8.10.1.2.6A Enhanced Performance Requirement Type C - Dual-Layer Spatial Multiplexing**

The requirements are specified in Table 8.10.1.2.6A-2, with the addition of the parameters in Table 8.10.1.2.6A-1 and the downlink physical channel setup according to Annex C.3.2. The purpose of these tests is to verify the rank-two performance for full RB allocation upon antenna ports 7 and 8.

**Table 8.10.1.2.6A-1: Test Parameters for Testing CDM-multiplexed DM RS (dual layer)**

Parameter	Unit	Test 1
Downlink power allocation	$\rho_A$	dB
	$\rho_B$	dB
	$\sigma$	dB
Cell-specific reference symbols		Antenna port 0 and antenna port 1
Beamforming model		Annex B.4.3
$N_{oc}$ at antenna port	dBm/15kHz	-98
Symbols for unused PRBs		OCNG (Note 2)
Number of allocated resource blocks	PRB	50
Reporting mode		PUSCH 3-1
PDSCH transmission mode		9
Note 1: $P_B = 1$ .		
Note 2: These physical resource blocks are assigned to an arbitrary number of virtual UEs with one PDSCH per virtual UE; the data transmitted over the OCNG PDSCHs shall be uncorrelated pseudo random data, which is QPSK modulated.		

**Table 8.10.1.2.6A-2: Enhanced Performance Requirement Type C for CDM-multiplexed DM RS (FRC)**

Test number	Bandwidth and MCS	Reference Channel	OCNG Pattern	Propagation Condition	Correlation Matrix and Antenna Configuration	Reference value		UE Category
						Fraction of Maximum Throughput (%)	SNR (dB)	
1	10 MHz 16QAM 1/2	R.32 TDD	OP.1 TDD	EPA5	2x4 Medium	70	15.8	≥2

### 8.10.1.2.6B Dual-Layer Spatial Multiplexing with altCQI-Table-1024QAM configured (User-Specific Reference Symbols)

The requirements are specified in Table 8.10.1.2.6B-2, with the addition of the parameters in Table 8.10.1.2.6B-1 and the downlink physical channel setup according to Annex C.3.2. The purpose of these tests is to verify the rank-two performance for full RB allocation upon antenna ports 7 and 8.

**Table 8.10.1.2.6B-1: Test Parameters for Testing CDM-multiplexed DM RS (dual layer) with multiple CSI-RS configurations**

Parameter	Unit	Test 1	
Downlink power allocation	$\rho_A$	dB	0
	$\rho_B$	dB	0 (Note 1)
	$\sigma$	dB	-3
Cell-specific reference symbols		Antenna port 0 and antenna port 1	
CSI reference signals		Antenna ports 15, 16, 17, 18	
Beamforming model		Annex B.4.3	
CSI-RS periodicity and subframe offset $T_{\text{CSI-RS}} / \Delta_{\text{CSI-RS}}$	Subframes	5 / 4	
CSI reference signal configuration		3	
Zero-power CSI-RS configuration $l_{\text{CSI-RS}} / \text{ZeroPowerCSI-RS}$ bitmap	Subframes / bitmap	N/A	
$N_{oc}$ at antenna port	dBm/15kHz	-98	
Symbols for unused PRBs		OCNG (Note 2)	
Number of allocated resource blocks	PRB	50	
Reporting mode		PUSCH 3-1	
PDSCH transmission mode		9	
Note 1: $P_B = 1$ . Note 2: These physical resource blocks are assigned to an arbitrary number of virtual UEs with one PDSCH per virtual UE; the data transmitted over the OCNG PDSCHs shall be uncorrelated pseudo random data, which is QPSK modulated.			

**Table 8.10.1.2.6B-2: Minimum performance Dual-Layer Spatial Multiplexing with altCQI-Table-1024QAM**

Test number	Bandwidth and MCS	Reference Channel	OCNG Pattern	Propagation Condition	Correlation Matrix and Antenna Configuration	Reference value		UE DL Category
						Fraction of Maximum Throughput (%)	SNR (dB)	
1	10 MHz 1024QAM	R.102 TDD	OP.1 TDD	EPA5	4x4 Low	70	29.0	20, ≥ 22

#### 8.10.1.2.7 Open-loop spatial multiplexing, 3 Layer Multiplexing with 4 Tx Antenna Ports (Cell-Specific Reference Symbols)

The requirements are specified in Table 8.10.1.2.7-2, with the addition of the parameters in Table 8.10.1.2.7-1 and the downlink physical channel setup according to Annex C.3.2.

**Table 8.10.1.2.7-1: Test parameters for Open Loop spatial multiplexing, 3 Layers with 4 Tx ports and 4 Rx ports**

Parameter	Unit	
Downlink power allocation	$\rho_A$	-6
	$\rho_B$	-6 (Note 1)
	$\sigma$	0
$N_{oc}$ at antenna port	dBm/15kHz	-98
Cell-specific reference signals		Antenna Ports 0,1,2,3
PDSCH transmission mode		3
PDSCH rank		3
CodeBookSubsetRestriction bitmap		0100
Note 1: $P_B = 1$ .		

**Table 8.10.1.2.7-2: Minimum performance Open Loop spatial multiplexing, 3 Layers with 4 Tx ports and 4 Rx ports**

Test number	Bandwidth and MCS	Reference Channel	OCNG Pattern	Propagation Condition	Correlation Matrix and Antenna Configuration	Reference value		UE Category
						Fraction of Maximum Throughput (%)	SNR (dB)	
1	10 MHz 64QAM	R.73 TDD	OP.1 TDD	EVA70	4x4 Low	70	14.9	≥5

#### 8.10.1.2.7A Enhanced Performance Requirement Type C - Open-loop spatial multiplexing, 3 Layer Multiplexing with 4 Tx Antenna Ports (Cell-Specific Reference Symbols)

The requirements are specified in Table 8.10.1.2.7A-2, with the addition of the parameters in Table 8.10.1.2.7A-1 and the downlink physical channel setup according to Annex C.3.2.

**Table 8.10.1.2.7A-1: Test parameters for Open Loop spatial multiplexing, 3 Layers with 4 Tx ports and 4 Rx ports**

Parameter	Unit	
Downlink power allocation	$\rho_A$	-6
	$\rho_B$	-6 (Note 1)
	$\sigma$	0
$N_{oc}$ at antenna port	dBm/15kHz	-98
Cell-specific reference signals		Antenna Ports 0,1,2,3
PDSCH transmission mode		3
PDSCH rank		3
CodeBookSubsetRestriction bitmap		0100
Note 1: $P_B = 1$ .		

**Table 8.10.1.2.7A-2: Enhanced Performance Requirement Type C for Open Loop spatial multiplexing, 3 Layers with 4 Tx ports**

Test number	Bandwidth and MCS	Reference Channel	OCNG Pattern	Propagation Condition	Correlation Matrix and Antenna Configuration	Reference value		UE Category
						Fraction of Maximum Throughput (%)	SNR (dB)	
1	10 MHz 16QAM	R.73-1 TDD	OP.1 TDD	EVA70	4x4 medium A	70	22.2	≥5

### 8.10.1.2.8 Closed-loop spatial multiplexing performance, 4 Layers spatial multiplexing 4 Tx antennas

The requirements are specified in Table 8.10.1.2.8-2, with the addition of the parameters in Table 8.10.1.2.8-1 and the downlink physical channel setup according to Annex C.3.2.

**Table 8.10.1.2.8-1: Test parameters for Closed Loop spatial multiplexing, 4 Layers spatial multiplexing with 4 Tx ports and 4 Rx ports**

Parameter	Unit	Test 1
Downlink power allocation	$\rho_A$	-6
	$\rho_B$	-6 (Note 1)
	$\sigma$	0
$N_{oc}$ at antenna port	dBm/15k Hz	-98
Cell-specific reference signals		Antenna ports 0,1,2,3
PDSCH transmission mode		4
PDSCH rank		4
Precoding granularity	PRB	50
PMI delay	ms	10 or 11
Reporting interval	ms	1 or 4
Reporting mode		PUSCH 3-1
CodeBookSubsetRestriction bitmap		0xFFFF000000000000
Uplink-Downlink Configuration		1
Special subframe configuration		4
Note 1: $P_B = 1$ .		

**Table 8.10.1.2.8-2: Minimum performance for Closed Loop spatial multiplexing, 4 Layers spatial multiplexing with 4 Tx ports and 4 Rx ports**

Test number	Bandwidth and MCS	Reference Channel	OCNG Pattern	Propagation Condition	Correlation Matrix and Antenna Configuration	Reference value		UE Category
						Fraction of Maximum Throughput (%)	SNR (dB)	
1	10 MHz 16QAM 1/2	R.74 TDD	OP.1 TDD	EPA5	4x4 Low	70	14.4	≥5

**8.10.1.2.9 4 Layer Spatial Multiplexing (User-Specific Reference Symbols)**

The requirements are specified in Table 8.10.1.2.9-2, with the addition of the parameters in Table 8.10.1.2.9-1 and the downlink physical channel setup according to Annex C.3.2.

**Table 8.10.1.2.9-1: Minimum performance for 4 Layer Spatial Multiplexing (User-Specific Reference Symbols)**

Parameter	Unit	Test 1	Test 1a
Downlink power allocation	$\rho_A$	dB	0
	$\rho_B$	dB	0 (Note 1)
	$\sigma$	dB	-3
Beamforming model		4 layer precoding based on WB PMI feedback	4 layer precoding based on WB PMI feedback
Cell-specific reference signals		Antenna ports 0,1	Antenna ports 0,1
CSI reference signals		Antenna ports 15,...,18	Antenna ports 15,...,18
Beamforming model		Annex B.4.3	Annex B.4.3
CSI-RS periodicity and subframe offset $T_{CSI-RS} / \Delta_{CSI-RS}$	Subframes	5 / 4	5 / 4
CSI reference signal configuration		3	3
Zero-power CSI-RS configuration $l_{CSI-RS} /$ ZeroPowerCSI-RS bitmap	Subframes / bitmap	4 / 0010000000000000	4 / 0010000000000000
$N_{oc}$ at antenna port	dBm/15kHz	-98	-98
Symbols for unused PRBs		OCNG (Note 3)	OCNG (Note 3)
Number of allocated resource blocks (Note 2)	PRB	50	50
Simultaneous transmission		No	No
PDSCH transmission mode		9	9
Precoding granularity		50	50
PMI delay		10 or 11	10 or 11
Reporting interval		1 or 4	1 or 4
Reporting mode		PUSCH 3-1	PUSCH 3-1
alternativeCodeBookEnabledFor4TX-r12		False	False
CodeBookSubsetRestriction bitmap		0xFFFF000000000000	0xFFFF000000000000
DMRS OCC length per port		2	4
Note 1: $P_B = 1$ . Note 2: 50 resource blocks are allocated in sub-frames 4, 9 and 41 resource blocks (RB0–RB20 and RB30–RB49) are allocated in sub-frame 0,1 and 6. Note 3: These physical resource blocks are assigned to an arbitrary number of virtual UEs with one PDSCH per virtual UE; the data transmitted over the OCNG PDSCHs shall be uncorrelated pseudo random data, which is QPSK modulated.			

**Table 8.10.1.2.9-2: Minimum performance for for 4 Layer Spatial Multiplexing (User-Specific Reference Symbols)**

Test number	Bandwidth and MCS	Reference Channel	OCNG Pattern	Propagation Condition	Correlation Matrix and Antenna Configuration	Reference value		UE Category
						Fraction of Maximum Throughput (%)	SNR (dB)	
1	10 MHz 16QAM	R.75 TDD	OP.1 TDD	EPA5	4x4 Low	70	19.0	≥5
1a	10MHz 16QAM	R.75A TDD	OP.1 TDD	EPA5	4x4 Low	70	[18.0]	≥5
NOTE:	For a UE supporting TM9 rank3/4 transmission based on DMRS OCC length 4, Test 1a will be run and Test 1 will be skipped. Otherwise, Test 1a is not applicable and only Test 1 will be run.							

#### 8.10.1.2.9A Enhanced Performance Requirement Type C - 4 Layer Spatial Multiplexing (User-Specific Reference Symbols)

The requirements are specified in Table 8.10.1.2.9A-2, with the addition of the parameters in Table 8.10.1.2.9A-1 and the downlink physical channel setup according to Annex C.3.2.

**Table 8.10.1.2.9A-1: Minimum performance for 4 Layer Spatial Multiplexing (User-Specific Reference Symbols)**

Parameter	Unit	Test 1	
Downlink power allocation	$\rho_A$	dB	0
	$\rho_B$	dB	0 (Note 1)
	$\sigma$	dB	-3
Cell-specific reference signals		Antenna ports 0,1	
CSI reference signals		Antenna ports 15,...,18	
Beamforming model		Annex B.4.3 (Note 4, 5)	
CSI-RS periodicity and subframe offset $T_{\text{CSI-RS}} / \Delta_{\text{CSI-RS}}$	Subframes	5 / 4	
CSI reference signal configuration		3	
Zero-power CSI-RS configuration $l_{\text{CSI-RS}} /$ ZeroPowerCSI-RS bitmap	Subframes / bitmap	4 / 0010000000000000	
$N_{\text{oc}}$ at antenna port	dBm/15kHz	-98	
Symbols for unused PRBs		OCNG (Note 3)	
Number of allocated resource blocks (Note 2)	PRB	50	
Simultaneous transmission		No	
PDSCH transmission mode		9	
Precoding granularity		50	
PMI delay		10 or 11	
Reporting interval		1 or 4	
Reporting mode		PUSCH 3-1	
alternativeCodeBookEnabledFor4TX-r12		False	
CodeBookSubsetRestriction bitmap		0xFFFFF00000000000	
Note 1: $P_B = 1$ .			
Note 2: 50 resource blocks are allocated in sub-frames 4, 9 and 41 resource blocks (RB0–RB20 and RB30–RB49) are allocated in sub-frame 0,1 and 6.			
Note 3: These physical resource blocks are assigned to an arbitrary number of virtual UEs with one PDSCH per virtual UE; the data transmitted over the OCNG PDSCHs shall be uncorrelated pseudo random data, which is QPSK modulated.			
Note 4: The precoder in clause B.4.3 follows UE recommended PMI.			
Note 5: If the UE reports in an available uplink reporting instance at subframe SF#n based on PMI estimation at a downlink SF not later than SF#(n-4), this reported PMI cannot be applied at the eNB downlink before SF#(n+4).			

**Table 8.10.1.2.9A-2: Minimum performance for 4 Layer Spatial Multiplexing (User-Specific Reference Symbols)**

Test number	Bandwidth and MCS	Reference Channel	OCNG Pattern	Propagation Condition	Correlation Matrix and Antenna Configuration	Reference value		UE Category
						Fraction of Maximum Throughput (%)	SNR (dB)	
1	10 MHz 16QAM	R.75 TDD	OP.1 TDD	EPA5	4x4 Medium A Xpol	70	18.1	≥5

#### 8.10.1.2.10 Closed loop spatial multiplexing performance - Single-Layer Spatial Multiplexing 2 Tx Antenna Port with CRS assistance information (Cell-Specific Reference Symbols)

The requirements are specified in Table 8.10.1.2.10-2, with the addition of parameters in Table 8.10.1.2.10-1. In Table 8.10.1.2.10-1, Cell 1 is the serving cell, and Cell 2 and Cell 3 are the aggressor cells. The downlink physical channel



setup is according to Annex C.3.2 for each of Cell 1, Cell 2 and Cell 3, respectively. The CRS assistance information [7] is provided to the UE and includes information on Cell 2 and Cell 3.

The purpose of the test is to verify the closed loop single layer TM4 performance under assumption that UE applies CRS interference mitigation in the scenario with 2 CRS antenna ports in the serving and aggressor cells.

**Table 8.10.1.2.10-1: Test Parameters**

Parameter	Unit	Cell 1	Cell 2	Cell 3
Uplink downlink configuration		1	1	1
Special subframe configuration		4	4	4
Downlink power allocation	$\rho_A$	dB	-3	-3
	$\rho_B$	dB	-3 (Note 1)	-3 (Note 1)
	$\sigma$	dB	0	0
$N_{oc}$ at antenna port	dBm/15kHz	-98	N/A	N/A
$\bar{E}_c/N_{oc}$	dB	Reference Value in Table 8.10.1.2.10-2	10.45	4.6
$BW_{Channel}$	MHz	10	10	10
Cyclic prefix		Normal	Normal	Normal
Subframe Configuration		Non-MBSFN	Non-MBSFN	Non-MBSFN
Cell ID		0	1	6
Cell-specific reference signals		Antenna ports 0,1		
Number of control OFDM symbols (CFI)		2	2	2
PDSCH transmission mode		4	N/A	N/A
Precoding granularity	PRB	50	N/A	N/A
PMI delay (Note 2)	ms	8	N/A	N/A
Reporting interval	ms	1 or 4 (Note 3)	N/A	N/A
Reporting mode		PUSCH 3-1	N/A	N/A
CodeBookSubsetRestriction bitmap		001111	N/A	N/A
ACK/NACK feedback mode		Multiplexing	N/A	N/A
Time Offset relative to Cell 1	$\mu$ s	N/A	3	-1
Frequency shift relative to Cell 1	Hz	N/A	300	-100
Interference model		N/A	As specified in clause B.5.3	As specified in clause B.5.3
Probability of occurrence of transmission in interference cells	%	N/A	20	20
Probability of occurrence of transmission rank in interfering cells	Rank 1	%	N/A	80
	Rank 2	%	N/A	20
Note 1: $P_{ij} = 1$ . Note 2: If the UE reports in an available uplink reporting instance at subframe SF #n based on PMI estimation at a downlink SF not later than SF #(n-4), this reported PMI cannot be applied at the eNB downlink before SF#(n+4). Note 3: For Uplink - downlink configuration 1 the reporting interval will alternate between 1ms and 4ms.				

**Table 8.10.1.2.10-2: Minimum Performance for PDSCH**

Test Number	Reference Channel	OCNG Pattern			Propagation Conditions (Note1)			Correlation Matrix and Antenna Configuration (Note 2)	Reference Value		UE Category
		Cell 1	Cell 2	Cell 3	Cell 1	Cell 2	Cell 3		Fraction of Maximum Throughput (%)	SNR (dB) (Note 3)	

1	R.35 TDD	OP.1 TDD	N/A	N/A	EVA5	EVA5	EVA5	2x4 low	70	11.2	≥2
Note 1: The propagation conditions for Cell 1, Cell 2 and Cell 3 are statistically independent. Note 2: The correlation matrix and antenna configuration apply for Cell 1, Cell 2 and Cell 3. Note 3: SNR corresponds to $\bar{E}_s/N_{oc}$ of cell 1.											

#### 8.10.1.2.11 Closed loop spatial multiplexing performance - Single-Layer Spatial Multiplexing 4 Tx Antenna Port with CRS assistance information (Cell-Specific Reference Symbols)

The requirements are specified in Table 8.10.1.2.11-2, with the addition of parameters in Table 8.10.1.2.11-1. In Table 8.10.1.2.11-1, Cell 1 is the serving cell, and Cell 2 is the aggressor cell. The downlink physical channel setup is according to Annex C.3.2 for each of Cell 1 and Cell 2, respectively. The CRS assistance information [7] is provided to the UE and includes information on Cell 2.

The purpose of the test is to verify the closed loop single layer TM4 performance under assumption that UE applies CRS interference mitigation in the scenario with 4 CRS antenna ports in the serving and aggressor cell.

**Table 8.10.1.2.11-1: Test Parameters**

Parameter	Unit	Cell 1	Cell 2
Uplink downlink configuration		1	1
Special subframe configuration		4	4
Downlink power allocation	$\rho_A$	dB	-6
	$\rho_B$	dB	-6 (Note 1)
	$\sigma$	dB	3
$N_{oc}$ at antenna port	dBm/15k Hz	-98	N/A
$\bar{E}_s/N_{oc}$	dB	Reference Value in Table 8.10.1.2.11-2	10.45
$BW_{Channel}$	MHz	10	10
Cyclic prefix		Normal	Normal
Subframe Configuration		Non-MBSFN	Non-MBSFN
Cell ID		0	1
Cell-specific reference signals		Antenna ports 0,1,2,3	
Number of control OFDM symbols (CFI)		2	2
PDSCH transmission mode		4	N/A
Precoding granularity	PRB	50	N/A
PMI delay (Note 2)	ms	8	N/A
Reporting interval	ms	1 or 4 (Note 3)	N/A
Reporting mode		PUSCH 3-1	N/A
CodeBookSubsetRestriction bitmap		000000000000FFFF	N/A
ACK/NACK feedback mode		Multiplexing	N/A
Time Offset relative to Cell 1	μs	N/A	3
Frequency shift relative to Cell 1	Hz	N/A	300
Interference model		N/A	As specified in clause B.5.3
Probability of occurrence of transmission in interference cells	%	N/A	20
Probability of occurrence of transmission rank in interfering cells	Rank 1	%	N/A
	Rank 2	%	N/A
Note 1: $P_B = 1$ . Note 2: If the UE reports in an available uplink reporting instance at subframe SF #n based on PMI estimation at a downlink SF not later than SF #(n-4), this reported PMI cannot be applied at the eNB downlink before SF #(n+4). Note 3: For Uplink - downlink configuration 1 the reporting interval will alternate between 1ms and 4ms.			

Table 8.10.1.2.11-2: Minimum Performance for PDSCH

Test Number	Reference Channel	OCNG Pattern		Propagation Conditions (Note1)		Correlation Matrix and Antenna Configuration (Note 2)	Reference Value		UE Category
		Cell 1	Cell 2	Cell 1	Cell 2		Fraction of Maximum Throughput (%)	SNR (dB) (Note 3)	
1	R.36-1 TDD	OP.1 TDD	N/A	EVA5	EVA5	4x4 low	70	9.8	≥2

Note 1: The propagation conditions for Cell 1 and Cell 2 are statistically independent.  
Note 2: The correlation matrix and antenna configuration apply for Cell 1 and Cell 2.  
Note 3: SNR corresponds to  $E_s/N_{oc}$  of cell 1.

#### 8.10.1.2.12 Closed loop spatial multiplexing performance - Single-Layer Spatial Multiplexing with CRS assistance information (User-Specific Reference Symbols)

The requirements are specified in Table 8.10.1.2.12-2, with the addition of parameters in Table 8.10.1.2.12-1. In Table 8.10.1.2.12-1, Cell 1 is the serving cell, and Cell 2 and Cell 3 are the aggressor cells. The downlink physical channel setup is according to Annex C.3.2 for each of Cell 1, Cell 2 and Cell 3, respectively. The CRS assistance information [7] is provided to the UE and includes information on Cell 2 and Cell 3.

The purpose of the test is to verify the closed loop single layer TM9 performance under assumption that UE applies CRS interference mitigation in the scenario with 2 CRS antenna ports in the serving and aggressor cells.

Table 8.10.1.2.12-1: Test Parameters

Parameter		Unit	Cell 1	Cell 2	Cell 3
Uplink downlink configuration			1	1	1
Special subframe configuration			4	4	4
Downlink power allocation	$\rho_A$	dB	0	0	0
	$\rho_B$	dB	0 (Note 1)	0 (Note 1)	0 (Note 1)
	$\sigma$	dB	-3	-3	-3

$N_{oc}$ at antenna port		dBm/15kHz	-98	N/A	N/A
$\bar{E}_s/N_{oc}$		dB	Reference Value in Table 8.10.1.2.12-2	10.45	4.6
$BW_{Channel}$		MHz	10	10	10
Cyclic prefix			Normal	Normal	Normal
Subframe Configuration			Non-MBSFN	Non-MBSFN	Non-MBSFN
Cell ID			0	1	6
Cell-specific reference signals			Antenna ports 0,1		
CSI reference signals			Antenna ports 15,16	N/A	N/A
CSI-RS periodicity and subframe offset	Subframes		5 / 4	N/A	N/A
$T_{CSI-RS} / \Delta_{CSI-RS}$					
CSI reference signal configuration			8	N/A	N/A
Zero-power CSI-RS configuration	Subframes / bitmap		4 / 0010000000000000	N/A	N/A
$I_{CSI-RS} / ZeroPowerCSI-RS$ bitmap					
Number of control OFDM symbols (CFI)			2	2	2
PDSCH transmission mode			9	N/A	N/A
Precoding granularity	PRB		Frequency domain: 50 PRB Time domain: 1 ms	N/A	N/A
Beamforming model			Annex B.4.1		
ACK/NACK feedback mode			Multiplexing	N/A	N/A
Time Offset relative to Cell 1	$\mu$ s		N/A	3	-1
Frequency shift relative to Cell 1	Hz		N/A	300	-100
Interference model			N/A	As specified in clause B.5.4	As specified in clause B.5.4
Probability of occurrence of transmission in interference cells	%		N/A	20	20
Probability of occurrence of transmission rank in interfering cells	Rank 1	%	N/A	80	80
	Rank 2	%	N/A	20	20
Note 1: $P_B = 1$ .					

Table 8.10.1.2.12-2: Minimum Performance for PDSCH

Test Number	Reference Channel	OCNG Pattern			Propagation Conditions (Note1)			Correlation Matrix and Antenna Configuration (Note 2)	Reference Value		UE Category
		Cell 1	Cell 2	Cell 3	Cell 1	Cell 2	Cell 3		Fraction of Maximum Throughput (%)	SNR (dB) (Note 3)	
1	R.X TDD	OP.1 TDD	N/A	N/A	EVA5	EVA5	EVA5	2x4 low	70	12.0	$\geq 2$
Note 1: The propagation conditions for Cell 1, Cell 2 and Cell 3 are statistically independent. Note 2: The correlation matrix and antenna configuration apply for Cell 1, Cell 2 and Cell 3. Note 3: SNR corresponds to $\bar{E}_s/N_{oc}$ of cell 1.											

### 8.10.1.2.13 Performance requirements for DCI format 2D and non Quasi Co-located Antenna Ports

#### 8.10.1.2.13.1 Minimum requirements for QCL Type C and 3 Layers Spatial Multiplexing

The requirements are specified in Table 8.10.1.2.13.1-3, with the additional parameters in Table 8.10.1.2.13.1-1 and Table 8.10.1.2.13.1-2. The purpose of this test is to verify the UE capability of supporting non quasi-co-located antenna ports when the UE receives DCI format 2D in a scenario with non-coherent joint transmission from two transmission points. The test verifies that the UE configured with quasi co-location type C performs correct tracking and compensation of the frequency and time difference between two transmission points, channel parameters estimation, channel estimation and rate matching behaviour according to the 'PDSCH RE Mapping and Quasi-Co-Location Indicator' signalling defined in [6]. In Table 8.10.1.2.13.1-1, transmission point 1 (TP 1) is the serving cell transmitting PDCCH, synchronization signals, PBCH and PDSCH, and transmission point 2 (TP 2) has different Cell ID and transmits PDSCH. In the test the PDSCH is transmitted from TP 1 and TP 2. The downlink physical channel setup for TP 1 is according to Annex C.3.2 and for TP 2 according to Annex C.3.2.

Table 8.10.1.2.13.1-1: Test Parameters

Parameter	Unit	TP 1	TP 2
Uplink downlink configuration		1	1
Special subframe configuration		4	4
Downlink power allocation	$\rho_A$	dB	0
	$\rho_B$	dB	0 (Note 1)
	$\sigma$	dB	-3
Beamforming model		Random beamforming (rank 2)	Random beamforming (rank 1)
Cell-specific reference signals		Antenna ports 0,1	Antenna ports 0,1
CSI reference signals 0		Antenna ports {15,16,17,18}	N/A
CSI-RS 0 periodicity and subframe offset $T_{\text{CSI-RS}} / \Delta_{\text{CSI-RS}}$	Subframes	5 / 4	
CSI reference signal 0 configuration		0	
CSI reference signals 1		N/A	Antenna ports {15,16,17,18}
CSI-RS 1 periodicity and subframe offset $T_{\text{CSI-RS}} / \Delta_{\text{CSI-RS}}$	Subframes		5 / 4
CSI reference signal 1 configuration			8
Zero-power CSI-RS 0 configuration $I_{\text{CSI-RS}} / \text{ZeroPower CSI-RS}$ bitmap	Subframes/bitmap	4/ 0010000000000000	N/A
Zero-power CSI-RS1 configuration $I_{\text{CSI-RS}} / \text{ZeroPower CSI-RS}$ bitmap	Subframes/bitmap	N/A	4/ 0010000000000000
$E_s / N_{oc}$	dB	SNR1	SNR2 = SNR1-3dB
$N_{oc}$ at antenna port	dBm/15kHz	-98	-98
$BW_{\text{Channel}}$	MHz	10	10
Cyclic Prefix		Normal	Normal
Cell ID		0	126
Number of control OFDM symbols / PDSCH start		2	2
Timing offset relative to TP 1	us	N/A	2
Frequency offset relative to TP 1	Hz	N/A	200
<i>qcl-Operation</i> , 'PDSCH RE Mapping and Quasi-Co-Location Indicator'		Type C, '00'	
PDSCH transmission mode (Note 2)		10	10
Number of allocated resource block		50	50
Note 1:	$P_B = 1$		
Note 2:	PDSCH transmission is done from both TPs (CW2 is transmitted from TP 1 and CW1 is transmitted from TP 2)		

**Table 8.10.1.2.13.1-2: Configurations of PQI and DL transmission hypothesis for each PQI set**

PQI set index	Parameters in each PQI set		DL transmission hypothesis for each PQI Set	
	NZP CSI-RS Index (For quasi co-location)	ZP CSI-RS configuration	TP 1	TP 2
PQI set 0	CSI-RS 0 for CW2 CSI-RS 1 for CW1	ZP CSI-RS 0	PDSCH	PDSCH

**Table 8.10.1.2.13.1-3: Performance Requirements**

Test Number	Reference Channel		OCNG Pattern		Propagation Conditions (Note1)		Correlation Matrix and Antenna Configuration (Note 2)	Reference Value		UE Category
	TP 1	TP 2	TP 1	TP 2	TP 1	TP 2		Fraction of Maximum Throughput (%)	SNR1 (dB) (Note 3)	
1	R.98 TDD	R.99 TDD	OP.1T DD	OP.1T DD	EPA5	EPA5	4x4 Low	70	11.1	≥2

Note 1: The propagation conditions for TP 1 and TP 2 are statistically independent.

Note 2: Correlation matrix and antenna configuration parameters apply for each of TP 1 and TP 2.

Note 3: SNR corresponds to  $E_s/N_{oc}$  of TP 1 and TP 2 as defined in clause 8.1.1.

### 8.10.1.2.13.2 Minimum requirements for QCL Type C and 4 Layers Spatial Multiplexing

The requirements are specified in Table 8.10.1.2.13.2-3, with the additional parameters in Table 8.10.1.2.13.2-1 and Table 8.10.1.2.13.2-2. The purpose of this test is to verify the UE capability of supporting non quasi-colocated antenna ports when the UE receives DCI format 2D in a scenario with non-coherent joint transmission from two transmission points. The test verifies that the UE configured with quasi co-location type C performs correct tracking and compensation of the frequency and time difference between two transmission points, channel parameters estimation, channel estimation and rate matching behaviour according to the 'PDSCH RE Mapping and Quasi-Co-Location Indicator' signalling defined in [6]. In Table 8.10.1.2.13.2-1, transmission point 1 (TP 1) is the serving cell transmitting PDCCH, synchronization signals, PBCH and PDSCH, and transmission point 2 (TP 2) has different Cell ID and transmits PDSCH. In the test the PDSCH is transmitted from TP 1 and TP 2. The downlink physical channel setup for TP 1 is according to Annex C.3.2 and for TP 2 according to Annex C.3.2.

Table 8.10.1.2.13.2-1: Test Parameters

Parameter	Unit	TP 1	TP 2
Uplink downlink configuration		1	1
Special subframe configuration		4	4
Downlink power allocation	$\rho_A$	dB	0
	$\rho_B$	dB	0 (Note 1)
	$\sigma$	dB	-3
Beamforming model		Random beamforming (rank 2)	Random beamforming (rank 2)
Cell-specific reference signals		Antenna ports 0,1,2,3	Antenna ports 0,1,2,3
CSI reference signals 0		Antenna ports {15,16,17,18}	N/A
CSI-RS 0 periodicity and subframe offset $T_{\text{CSI-RS}} / \Delta_{\text{CSI-RS}}$	Subframes	5 / 4	
CSI reference signal 0 configuration		0	
CSI reference signals 1		N/A	Antenna ports {15,16,17,18}
CSI-RS 1 periodicity and subframe offset $T_{\text{CSI-RS}} / \Delta_{\text{CSI-RS}}$	Subframes		5 / 4
CSI reference signal 1 configuration			8
Zero-power CSI-RS 0 configuration $I_{\text{CSI-RS}} / \text{ZeroPower CSI-RS}$ bitmap	Subframes/bitmap	4/ 0010000000000000	N/A
Zero-power CSI-RS1 configuration $I_{\text{CSI-RS}} / \text{ZeroPower CSI-RS}$ bitmap	Subframes/bitmap	N/A	4/ 0010000000000000
$E_s / N_{oc}$	dB	SNR1	SNR2 = SNR1
$N_{oc}$ at antenna port	dBm/15kHz	-98	-98
$BW_{\text{Channel}}$	MHz	10	10
Cyclic Prefix		Normal	Normal
Cell ID		0	126
Number of control OFDM symbols / PDSCH start		2	2
Timing offset relative to TP 1	us	N/A	2
Frequency offset relative to TP 1	Hz	N/A	200
<i>qcl-Operation</i> , 'PDSCH RE Mapping and Quasi-Co-Location Indicator'		Type C, '00'	
PDSCH transmission mode (Note 2)		10	10
Number of allocated resource block		50	50
Note 1:	$P_B = 1$		
Note 2:	PDSCH transmission is done from both TPs (CW1 is transmitted from TP 1 and CW2 is transmitted from TP 2)		



**Table 8.10.1.2.13.2-2: Configurations of PQI and DL transmission hypothesis for each PQI set**

PQI set index	Parameters in each PQI set		DL transmission hypothesis for each PQI Set	
	NZP CSI-RS Index (For quasi co-location)	ZP CSI-RS configuration	TP 1	TP 2
PQI set 0	CSI-RS 0 for CW1 CSI-RS 1 for CW2	ZP CSI-RS 0	PDSCH	PDSCH

**Table 8.10.1.2.13.2-3: Performance Requirements**

Test Number	Reference Channel		OCNG Pattern		Propagation Conditions (Note1)		Correlation Matrix and Antenna Configuration (Note 2)	Reference Value		UE Category
	TP 1	TP 2	TP 1	TP 2	TP 1	TP 2		Fraction of Maximum Throughput (%)	SNR1 (dB) (Note 3)	
1	R.10 0 TDD	R.10 0 TDD	OP.1T DD	OP.1T DD	EPA5	EPA5	4x4 Low	70	15.4	≥2

Note 1: The propagation conditions for TP 1 and TP 2 are statistically independent.  
Note 2: Correlation matrix and antenna configuration parameters apply for each of TP 1 and TP 2.  
Note 3: SNR corresponds to  $E_s/N_{oc}$  of TP 1 and TP 2 as defined in clause 8.1.1.

**8.10.1.2.14 HST-SFN performance****8.10.1.2.14.1 Minimum Requirement for Rel-16 further enhanced HST**

The requirements are specified in Table 8.10.1.2.14-2, with the addition of the parameters in Table 8.10.1.2.14-1 and the downlink physical channel setup according to Annex C.3.2. The purpose of this test is to verify UE performance in the HST-SFN-500 scenario. The test for HST-SFN-500 scenario defined in B.3B is applied when *highSpeedEnhDemodFlag2-r16* [7] is received.

**Table 8.10.1.2.14-1: Void****Table 8.10.1.2.14-2: Void**

NOTE: Table 8.10.1.2.14-1 and Table 8.10.1.2.14-2 are moved to subclause 8.10.1.2.14.1 as Table 8.10.1.2.14.1-1 and Table 8.10.1.2.14.1-2.

**Table 8.10.1.2.14.1-1: Test Parameters for UE performance in HST-SFN-500 scenario (FRC)**

Parameter	Unit	Test 1	
Downlink power allocation	$\rho_A$	dB	-3
	$\rho_B$	dB	-3 (NOTE 1)
	$\sigma$	dB	0
$N_{oc}$ at antenna port		dBm/15kHz	-98
ACK/NACK feedback mode			Multiplexing
PDSCH transmission mode			3
NOTE 1: $P_B = 1$ .			

**Table 8.10.1.2.14.1-2: Minimum performance UE in HST-SFN-500 scenario (FRC)**

Test number	Bandwidth	Reference Channel	OCNG Pattern	Propagation Condition	Correlation Matrix and Antenna Configuration	Reference value		UE Category
						Fraction of Maximum Throughput (%)	SNR (dB)	
1 <sup>NOTE 2</sup>	10 MHz	R.87-1 TDD	OP.1 TDD	HST-SFN-500	2x4	70	6.8	≥ 1

NOTE 1: Test case applicability is defined in 8.1.2.1 and 8.1.2.6.  
NOTE 2: The requirement defined is based on the normalized channel model, i.e. the power of each tap is normalized to the instantaneous total received power from four taps.

## 8.10.2 PDCCH/PCFICH

### 8.10.2.1 FDD

The parameters specified in Table 8.10.2.1-1 are valid for all FDD tests unless otherwise stated.

**Table 8.10.2.1-1: Test Parameters for PDCCH/PCFICH with 4 Rx Antenna Ports**

Parameter	Unit	Single antenna port	Transmit diversity
Number of PDCCH symbols	symbols	2	2
PHICH Ng (Note 1)		1	1
PHICH duration		Normal	Normal
Unused RE-s and PRB-s (Note 2)		OCNG	OCNG
Cell ID		0	0
Downlink power allocation	$\rho_A$	dB	-3
	$\rho_B$	dB	-3
	$\sigma$	dB	0
$N_{oc}$ at antenna port	dBm/15kHz	-98	-98
Cyclic prefix		Normal	Normal

Note 1: according to Clause 6.9 in TS 36.211 [4].  
Note 2: PDSCH is mapped as OCNG.

#### 8.10.2.1.1 Single-antenna port performance

For the parameters specified in Table 8.10.2.1-1 the average probability of a missed downlink scheduling grant ( $P_{m-dsg}$ ) shall be below the specified value in Table 8.10.2.1.1-1. The downlink physical setup is in accordance with Annex C.3.2.

**Table 8.10.2.1.1-1: Minimum performance PDCCH/PCFICH with 4Rx Antenna ports**

Test number	Bandwidth	Aggregation level	Reference Channel	OCNG Pattern	Propagation Condition	Antenna configuration and correlation Matrix	Reference value	
							$P_{m-dsg}$ (%)	SNR (dB)
1	10 MHz	8 CCE	R.15 FDD	OP.1 FDD	ETU70	1x4 Low	1	-5.4

#### 8.10.2.1.2 Transmit diversity performance with 2 Tx Antenna Ports

For the parameters specified in Table 8.10.2.1-1 the average probability of a missed downlink scheduling grant ( $P_{m-dsg}$ ) shall be below the specified value in Table 8.10.2.1.2-1. The downlink physical setup is in accordance with Annex C.3.2.

**Table 8.10.2.1.2-1: Minimum performance PDCCH/PCFICH with 4 Rx Antenna Ports**

Test number	Bandwidth	Aggregation level	Reference Channel	OCNG Pattern	Propagation Condition	Antenna configuration and correlation Matrix	Reference value	
							Pm-dsg (%)	SNR (dB)
1	10 MHz	4 CCE	R.16 FDD	OP.1 FDD	EVA70	2 x 4 Low	1	-3.5

**8.10.2.1.3 Transmit diversity performance with 4 Tx Antenna Ports**

For the parameters specified in Table 8.10.2.1-1 the average probability of a missed downlink scheduling grant (Pm-dsg) shall be below the specified value in Table 8.10.2.1.3-1. The downlink physical setup is in accordance with Annex C.3.2.

**Table 8.10.2.1.3-1: Minimum performance PDCCH/PCFICH with 4Rx Antenna ports**

Test number	Bandwidth	Aggregation level	Reference Channel	OCNG Pattern	Propagation Condition	Antenna configuration and correlation Matrix	Reference value	
							Pm-dsg (%)	SNR (dB)
1	5 MHz	2 CCE	R.17 FDD	OP.1 FDD	EPA5	4 x 4 Medium A Xpol	1	-0.4

**8.10.2.1.4 Enhanced Downlink Control Channel Performance Requirement Type A - 4 Tx Antenna Port with Non-Colliding CRS Dominant Interferer**

The purpose of this test is to verify the Enhanced Downlink Control Channel Performance Requirement Type A for PDCCH/PCFICH with 4 transmit antennas for the case of dominant interferer with the non-colliding CRS pattern and applying interference model defined in clause B.7.1.

For the parameters specified in Table 8.10.2.1.4-1, the average probability of a missed downlink scheduling grant (Pm-dsg) shall be below the specified value in Table 8.10.2.1.4-2. In Table 8.10.2.1.4-1, Cell 1 is the serving cell, and Cell 2 is the aggressor cell. The downlink physical channel setup is according to Annex C.3.2 for each of Cell 1 and Cell, respectively.

Table 8.10.2.1.4-1: Test Parameters for PDCCH/PCFICH

Parameter		Unit	Cell 1	Cell 2
Downlink power allocation	PDCCH_RA OCNG_RA	dB	-3	-3
	PHICH_RA	dB	-3	N/A
	PCFICH_RB PDCCH_RB OCNG_RB	dB	-3	-3
	PHICH_RB	dB	-3	N/A
Cell-specific reference signals			Antenna ports 0,1,2,3	
$N_{oc}$ at antenna port		dBm/15kHz	-98	
$\bar{E}_s/N_{oc}$		dB	As defined in Table 8.10.2.1.4-2	13.91
BW <sub>Channel</sub>		MHz	10	10
Cyclic Prefix			Normal	Normal
Cell ID			0	1
Subframe Configuration			Non-MBSFN	Non-MBSFN
Number of DL control region OFDM symbols			2	2
CFI indicated in PCFICH			2	2
PHICH Ng (Note 1)			1/6	N/A
PHICH duration			Normal	N/A
PDSCH TM			4	N/A
Interference model			NA	As specified in clause B.7.1
Unused RE-s and PRB-s (Note 2)			OCNG	OCNG
Time Offset relative to Cell 1		$\mu$ s	N/A	2
Frequency shift relative to Cell 1		Hz	N/A	200
Note 1: According to Clause 6.9 in TS 36.211 [4].				
Note 2: For Cell 2 unused RE-s and PRB-s do not include control region REs.				

Table 8.10.2.1.4-2: Minimum Performance for PDCCH/PCFICH for Enhanced Downlink Control Channel Performance Requirement Type A

Test Number	Aggregation level	Reference Channel	OCNG Pattern (Note 1)	Propagation Conditions (Note 2)		Antenna Configuration and Correlation Matrix (Note 3)	Reference Value	
				Cell 1	Cell 2		Pm-dsg (%)	SNR (dB) (Note 4)
1	1 CCE	R.17-2 FDD	OP.1 FDD	EPA5	EPA5	4x4 Low	1	16.5
Note 1: The OCNG pattern applies for Cell 1 and Cell 2.								
Note 2: The propagation conditions for Cell 1 and Cell 2 are statistically independent.								
Note 3: The correlation matrix and antenna configuration apply for Cell 1 and Cell 2.								
Note 4: SNR corresponds to $E_s/N_{oc}$ of Cell 1 as defined in clause 8.1.1.								

## 8.10.2.2 TDD

Table 8.10.2.2-1: Test Parameters for PDCCH/PCFICH

Parameter	Unit	Single antenna port	Transmit diversity	
Uplink downlink configuration (Note 1)		0	0	
Special subframe configuration (Note 2)		4	4	
Number of PDCCH symbols	symbols	2	2	
PHICH Ng (Note 3)		1	1	
PHICH duration		Normal	Normal	
Unused RE-s and PRB-s (Note 4)		OCNG	OCNG	
Cell ID		0	0	
Downlink power allocation	$\rho_A$	dB	0	-3
	$\rho_B$	dB	0	-3
	$\sigma$	dB	0	0
$N_{oc}$ at antenna port	dBm/15kHz	-98	-98	
Cyclic prefix		Normal	Normal	
ACK/NACK feedback mode		Multiplexing	Multiplexing	
Note 1: as specified in Table 4.2-2 in TS 36.211 [4]. Note 2: as specified in Table 4.2-1 in TS 36.211 [4]. Note 3: according to Clause 6.9 in TS 36.211 [4]. Note 4: PDSCH is mapped as OCNG.				

## 8.10.2.2.1 Single-antenna port performance

For the parameters specified in Table 8.10.2.2-1 the average probability of a missed downlink scheduling grant (Pm-dsg) shall be below the specified value in Table 8.10.2.2.1-1. The downlink physical setup is in accordance with Annex C.3.2.

Table 8.10.2.2.1-1: Minimum performance PDCCH/PCFICH

Test number	Bandwidth	Aggregation level	Reference Channel	OCNG Pattern	Propagation Condition	Antenna configuration and correlation Matrix	Reference value	
							Pm-dsg (%)	SNR (dB)
1	10 MHz	8 CCE	R.15 TDD	OP.1 TDD	ETU70	1x4 Low	1	-4.7

## 8.10.2.2.2 Transmit diversity performance with 2 Tx Antenna Ports

For the parameters specified in Table 8.10.2.2-1 the average probability of a missed downlink scheduling grant (Pm-dsg) shall be below the specified value in Table 8.10.2.2.2-1. The downlink physical setup is in accordance with Annex C.3.2.

Table 8.10.2.2.2-1: Minimum performance PDCCH/PCFICH with 4Rx Antenna ports

Test number	Bandwidth	Aggregation level	Reference Channel	OCNG Pattern	Propagation Condition	Antenna configuration and correlation Matrix	Reference value	
							Pm-dsg (%)	SNR (dB)
1	10 MHz	4 CCE	R.16 TDD	OP.1 TDD	EVA70	2 x 4 Low	1	-3.2

## 8.10.2.2.3 Transmit diversity performance with 4 Tx Antenna Ports

For the parameters specified in Table 8.10.2.2-1 the average probability of a missed downlink scheduling grant (Pm-dsg) shall be below the specified value in Table 8.10.2.2.3-1. The downlink physical setup is in accordance with Annex C.3.2.

Table 8.10.2.2.3-1: Minimum performance PDCCH/PCFICH with 4Rx Antenna ports

Test number	Bandwidth	Aggregation level	Reference Channel	OCNG Pattern	Propagation Condition	Antenna configuration and correlation Matrix	Reference value	
							Pm-dsg (%)	SNR (dB)
1	5 MHz	2 CCE	R.17 TDD	OP.1 TDD	EPA5	4 x 4 Medium A Xpol	1	0.0

## 8.10.2.2.4 Enhanced Downlink Control Channel Performance Requirement Type A - 4 Tx Antenna Port with Non-Colliding CRS Dominant Interferer

The purpose of this test is to verify the Enhanced Downlink Control Channel Performance Requirement Type A for PDCCH/PCFICH with 4 transmit antennas for the case of dominant interferer with the non-colliding CRS pattern and applying interference model defined in clause B.7.1.

For the parameters specified in Table 8.10.2.2.4-1, the average probability of a missed downlink scheduling grant (Pm-dsg) shall be below the specified value in Table 8.10.2.2.4-2. In Table 8.10.2.2.4-1, Cell 1 is the serving cell, and Cell 2 is the aggressor cell. The downlink physical channel setup is according to Annex C.3.2 for each of Cell 1 and Cell, respectively.

Table 8.10.2.2.4-1: Test Parameters for PDCCH/PCFICH

Parameter		Unit	Cell 1	Cell 2
Downlink power allocation	PDCCH_RA	dB	-3	-3
	OCNG_RA	dB	-3	N/A
	PCFICH_RB	dB	-3	-3
	PDCCH_RB	dB	-3	-3
	OCNG_RB	dB	-3	N/A
Cell-specific reference signals			Antenna ports 0,1,2,3	
$N_{oc}$ at antenna port		dBm/15kHz	-98	
$\tilde{E}_s/N_{oc}$		dB	As defined in Table 8.10.2.1.4-2	13.91
BW <sub>channel</sub>		MHz	10	10
Cyclic Prefix			Normal	Normal
Cell ID			0	1
UL/DL Configuration			0	0
Special Subframe Configuration			4	4
Subframe Configuration			Non-MBSFN	Non-MBSFN
Number of DL control region OFDM symbols			2	
CFI indicated in PCFICH			2	
PHICH Ng (Note 1)			1/6	N/A
PHICH duration			Normal	N/A
PDSCH TM			4	N/A
Interference model			NA	As specified in clause B.7.1
Unused RE-s and PRB-s (Note 2)			OCNG	OCNG
Time Offset relative to Cell 1		μs	N/A	2
Frequency shift relative to Cell 1		Hz	N/A	200
Note 1: According to Clause 6.9 in TS 36.211 [4].				
Note 2: For Cell 2 unused RE-s and PRB-s do not include control region REs.				

**Table 8.10.2.1.4-2: Minimum Performance for PDCCH/PCFICH for Enhanced Downlink Control Channel Performance Requirement Type A**

Test Number	Aggregation level	Reference Channel	OCNG Pattern (Note 1)	Propagation Conditions (Note 2)		Antenna Configuration and Correlation Matrix (Note 3)	Reference Value	
				Cell 1	Cell 2		Pm-dsg (%)	SNR (dB) (Note 4)
1	1 CCE	R.17-2 TDD	OP.1 TDD	EPA5	EPA5	4x4 Low	1	17.9
Note 1: The OCNG pattern applies for Cell 1 and Cell 2. Note 2: The propagation conditions for Cell 1 and Cell 2 are statistically independent. Note 3: The correlation matrix and antenna configuration apply for Cell 1 and Cell 2. Note 4: SNR corresponds to $E_s/N_{oc}$ of Cell 1 as defined in clause 8.1.1.								

### 8.10.3 PHICH

The receiver characteristics of the PHICH are determined by the probability of miss-detecting an ACK for a NACK (Pm-an). It is assumed that there is no bias applied to the detection of ACK and NACK (zero-threshold detection).

#### 8.10.3.1 FDD

The parameters specified in Table 8.10.3.1-1 are valid for all FDD tests with 4Rx unless otherwise stated.

**Table 8.10.3.1-1: Test Parameters for PHICH with 4 Rx Antenna Ports**

Parameter		Unit	Single antenna port	Transmit diversity
Downlink power allocation	$\rho_A$	dB	0	-3
	$\rho_B$	dB	0	-3
	$\sigma$	dB	0	0
PHICH duration			Normal	Normal
PHICH Ng (Note 1)			Ng = 1	Ng = 1
PDCCH Content			UL Grant should be included with the proper information aligned with A.3.6. DL Grant: Note 2	
Unused RE-s and PRB-s (Note 2)			OCNG	OCNG
Cell ID			0	0
$N_{oc}$ at antenna port		dBm/15kHz	-98	-98
Cyclic prefix			Normal	Normal
Note 1: according to Clause 6.9 in TS 36.211 [4]. Note 2: Reference measurement channel R.15 FDD for Single Tx Antenna 8.10.3.1.1, R15-2 FDD for Transmit Diversity with 2Tx Antenna Port 8.10.3.1.2, R17 FDD for Transmit diversity with 4Tx Antenna Port 8.10.3.1.3, according to Table A.3.5.1-1 with one sided dynamic OCNG Pattern OP.1 FDD as described in Annex A.5.1.1 for the serving cell.				

##### 8.10.3.1.1 Single Tx Antenna Port performance

For the parameters specified in Table 8.10.3.1-1 the average probability of a miss-detecting ACK for NACK (Pm-an) shall be below the specified value in Table 8.10.3.1.1-1. The downlink physical setup is in accordance with Annex C.3.2.

**Table 8.10.3.1.1-1: Minimum performance PHICH with 4 Rx Antenna Ports**

Test number	Bandwidth	Reference Channel	OCNG Pattern	Propagation Condition	Antenna configuration and correlation Matrix	Reference value	
						Pm-an (%)	SNR (dB)
1	10 MHz	R.18	OP.1 FDD	ETU70	1 x 4 Low	0.1	1.6

**8.10.3.1.2 Transmit diversity performance with 2 Tx Antenna Ports**

For the parameters specified in Table 8.10.3.1-1 the average probability of a miss-detecting ACK for NACK (Pm-an) shall be below the specified value in Table 8.10.3.1.2-1. The downlink physical setup is in accordance with Annex C.3.2.

**Table 8.10.3.1.2-1: Minimum performance PHICH with 4 Rx Antenna Ports**

Test number	Bandwidth	Reference Channel	OCNG Pattern	Propagation Condition	Antenna configuration and correlation Matrix	Reference value	
						Pm-an (%)	SNR (dB)
1	10 MHz	R.19	OP.1 FDD	EVA70	2 x 4 Low	0.1	0.6

**8.10.3.1.3 Transmit diversity performance with 4 Tx Antenna Ports**

For the parameters specified in Table 8.10.3.1-1 the average probability of a miss-detecting ACK for NACK (Pm-an) shall be below the specified value in Table 8.10.3.1.3-1. The downlink physical setup is in accordance with Annex C.3.2.

**Table 8.10.3.1.3-1: Minimum performance PHICH with 4 Rx Antenna Ports**

Test number	Bandwidth	Reference Channel	OCNG Pattern	Propagation Condition	Antenna configuration and correlation Matrix	Reference value	
						Pm-an (%)	SNR (dB)
1	5 MHz	R.20	OP.1 FDD	EPA5	4 x 4 Medium correlation A, Cross polarized	0.1	0.1

**8.10.3.2 TDD**

The parameters specified in Table 8.10.3.2-1 are valid for all TDD tests with 4 Rx unless otherwise stated.



Table 8.10.3.2-1: Test Parameters for PHICH with 4 Rx Antenna Ports

Parameter	Unit	Single antenna port	Transmit diversity
Uplink downlink configuration (Note 1)		1	1
Special subframe configuration (Note 2)		4	4
Downlink power allocation	$\rho_A$	dB	-3
	$\rho_B$	dB	-3
	$\sigma$	dB	0
PHICH duration		Normal	Normal
PHICH Ng (Note 1)		Ng = 1	Ng = 1
PDCCH Content		UL Grant should be included with the proper information aligned with A.3.6. DL Grant: Note 4	
Unused RE-s and PRB-s (Note 4)		OCNG	OCNG
Cell ID		0	0
$N_{oc}$ at antenna port	dBm/15kHz	-98	-98
Cyclic prefix		Normal	Normal
ACK/NACK feedback mode		Multiplexing	Multiplexing
Note 1: as specified in Table 4.2-2 in TS 36.211 [4]. Note 2: as specified in Table 4.2-1 in TS 36.211 [4]. Note 3: according to Clause 6.9 in TS 36.211 [4]. Note 4: Reference measurement channel R.15 TDD for Single Tx Antenna 8.10.3.2.1, R15-2 TDD for Transmit Diversity with 2Tx Antenna Port 8.10.3.2.2, R17 TDD for Transmit diversity with 4Tx Antenna Port 8.10.3.2.3, according to Table A.3.5.2-1 with one sided dynamic OCNG Pattern OP.1 TDD as described in Annex A.5.2.1 for the serving cell			

## 8.10.3.2.1 Single Tx Antenna Port performance

For the parameters specified in Table 8.10.3.2-1 the average probability of a miss-detecting ACK for NACK ( $P_{m-an}$ ) shall be below the specified value in Table 8.10.3.2.1-1. The downlink physical setup is in accordance with Annex C.3.2.

Table 8.10.3.2.1-1: Minimum performance PHICH with 4 Rx Antenna Ports

Test number	Bandwidth	Reference Channel	OCNG Pattern	Propagation Condition	Antenna configuration and correlation Matrix	Reference value	
						$P_{m-an}$ (%)	SNR (dB)
1	10 MHz	R.18	OP.1 TDD	ETU70	1 x 4 Low	0.1	1.7

## 8.10.3.2.2 Transmit diversity performance with 2 Tx Antenna Ports

For the parameters specified in Table 8.10.3.2-1 the average probability of a miss-detecting ACK for NACK ( $P_{m-an}$ ) shall be below the specified value in Table 8.10.3.2.2-1. The downlink physical setup is in accordance with Annex C.3.2.

Table 8.10.3.2.2-1: Minimum performance PHICH with 4 Rx Antenna Ports

Test number	Bandwidth	Reference Channel	OCNG Pattern	Propagation Condition	Antenna configuration and correlation Matrix	Reference value	
						$P_{m-an}$ (%)	SNR (dB)
1	10 MHz	R.19	OP.1 TDD	EVA70	2 x 4 Low	0.1	0.9

### 8.10.3.2.3 Transmit diversity performance with 4 Tx Antenna Ports

For the parameters specified in Table 8.10.3.2-1 the average probability of a miss-detecting ACK for NACK ( $P_{m-an}$ ) shall be below the specified value in Table 8.10.3.2.3-1. The downlink physical setup is in accordance with Annex C.3.2.

**Table 8.10.3.2.3-1: Minimum performance PHICH with 4 Rx Antenna Ports**

Test number	Bandwidth	Reference Channel	OCNG Pattern	Propagation Condition	Antenna configuration and correlation Matrix	Reference value	
						$P_{m-an}$ (%)	SNR (dB)
1	5 MHz	R.20	OP.1 TDD	EPA5	4 x 4 Medium correlation A, Cross polarized	0.1	0.3

## 8.10.4 ePDCCH

The receiver characteristics of the EPDCCH are determined by the probability of miss-detection of the Downlink Scheduling Grant ( $P_{m-dsg}$ ). For the distributed transmission tests in 8.10.4.1, EPDCCH and PCFICH are tested jointly, i.e. a miss detection of PCFICH implies a miss detection of EPDCCH. For other tests, EPDCCH and PCFICH are not tested jointly.

### 8.10.4.1 Distributed Transmission with 4Rx

#### 8.10.4.1.1 FDD

The parameters specified in Table 8.10.4.1.1-1 are valid for all FDD distributed EPDCCH test with 4Rx unless otherwise stated.

Table 8.10.4.1.1-1: Test Parameters for Distributed EPDCCH with 4Rx

Parameter	Unit	Value	
Number of PDCCH symbols	symbols	2 (Note 1)	
PHICH duration		Normal	
Unused RE-s and PRB-s		OCNG	
Cell ID		0	
Downlink power allocation	$\rho_A$	dB	-3
	$\rho_B$	dB	-3
	$\sigma$	dB	0
	$\delta$	dB	3
$N_{oc}$ at antenna port	dBm/15 kHz	-98	
Cyclic prefix		Normal	
Subframe Configuration		Non-MBSFN	
Precoder Update Granularity	PRB	1	
	ms	1	
Beamforming Pre-Coder		Annex B.4.4	
Cell Specific Reference Signal		Port 0 and 1	
Number of EPDCCH Sets Configured		2 (Note 2)	
Number of PRB per EPDCCH Set		4 (1 <sup>st</sup> Set)	
		8 (2 <sup>nd</sup> Set)	
EPDCCH Subframe Monitoring		NA	
PDSCH TM		TM3	
DCI Format		2A	
Note 1: The starting symbol for EPDCCH is derived from the PCFICH. RRC signalling <i>epdcch-StartSymbol-r11</i> is not configured. Note 2: The two sets are distributed EPDCCH sets and non-overlapping with PRB = {3, 17, 31, 45} for the first set and PRB = {0, 7, 14, 21, 28, 35, 42, 49} for the second set. EPDCCH is scheduled in the first set for Test 1 and second set for Test 2, respectively. Both sets are always configured.			

For the parameters specified in Table 8.10.4.1.1-1 the average probability of a missed downlink scheduling grant (Pm-dsg) shall be below the specified value in Table 8.10.4.1.1-2. The downlink physical setup is in accordance with Annex C.3.2.

Table 8.10.4.1.1-2: Minimum performance Distributed EPDCCH with 4Rx Antenna ports

Test number	Bandwidth	Aggregation level	Reference Channel	OCNG Pattern	Propagation Condition	Antenna configuration and correlation Matrix	Reference value	
							Pm-dsg (%)	SNR (dB)
1	10 MHz	4 ECCE	R.55 FDD	OP.7 FDD	EVA5	2 x 4 Low	1	-0.7
2	10 MHz	16 ECCE	R.56 FDD	OP.7 FDD	EVA70	2 x 4 Low	1	-5.8

#### 8.10.4.1.2 TDD

The parameters specified in Table 8.10.4.1.1-1 are valid for all TDD distributed EPDCCH tests with 4Rx unless otherwise stated.

**Table 8.10.4.1.2-1: Test Parameters for Distributed EPDCCH with 4Rx**

Parameter	Unit	Value	
Number of PDCCH symbols	symbols	2 (Note 1)	
PHICH duration		Normal	
Unused RE-s and PRB-s		OCNG	
Cell ID		0	
Downlink power allocation	$\rho_A$	dB	-3
	$\rho_B$	dB	-3
	$\sigma$	dB	0
	$\delta$	dB	3
$N_{oc}$ at antenna port	dBm/15 kHz	-98	
Cyclic prefix		Normal	
Subframe Configuration		Non-MBSFN	
Precoder Update Granularity	PRB	1	
	ms	1	
Beamforming Pre-Coder		Annex B.4.4	
Cell Specific Reference Signal		Port 0 and 1	
Number of EPDCCH Sets Configured		2 (Note 2)	
Number of PRB per EPDCCH Set		4 (1 <sup>st</sup> Set)	
		8 (2 <sup>nd</sup> Set)	
EPDCCH Subframe Monitoring		NA	
PDSCH TM		TM3	
DCI Format		2A	
TDD UL/DL Configuration		0	
TDD Special Subframe		1 (Note 3)	
Note 1: The starting symbol for EPDCCH is derived from the PCFICH. RRC signalling <i>epdcch-StartSymbol-r11</i> is not configured. Note 2: The two sets are distributed EPDCCH sets and non-overlapping with PRB = {3, 17, 31, 45} for the first set and PRB = {0, 7, 14, 21, 28, 35, 42, 49} for the second set. EPDCCH is scheduled in the first set for Test 1 and second set for Test 2, respectively. Both sets are always configured. Note 3: Demodulation performance is averaged over normal and special subframe.			

For the parameters specified in Table 8.10.4.1.2-1 the average probability of a missed downlink scheduling grant ( $P_{m-dsg}$ ) shall be below the specified value in Table 8.10.4.1.2-2. The downlink physical setup is in accordance with Annex C.3.2.

**Table 8.10.4.1.2-2: Minimum performance Distributed EPDCCH with 4Rx Antenna ports**

Test number	Bandwidth	Aggregation level	Reference Channel	OCNG Pattern	Propagation Condition	Antenna configuration and correlation Matrix	Reference value	
							$P_{m-dsg}$ (%)	SNR (dB)
1	10 MHz	4 ECCE	R.55 TDD	OP.7 TDD	EVA5	2 x 4 Low	1	-0.7
2	10 MHz	16 ECCE	R.56 TDD	OP.7 TDD	EVA70	2 x 4 Low	1	-5.8

## 8.10.4.2 Localized Transmission with TM9 and 4Rx

### 8.10.4.2.1 FDD

The parameters specified in Table 8.10.4.2.1-1 are valid for all FDD TM9 localized ePDCCH tests with 4Rx unless otherwise stated.

**Table 8.10.4.2.1-1: Test Parameters for Localized EPDCCH with TM9 and 4Rx**

Parameter	Unit	Value
Number of PDCCH symbols	symbols	1 (Note 1)

EPDCCH starting symbol		symbols	2 (Note 1)
PHICH duration			Normal
Unused RE-s and PRB-s			OCNG
Cell ID			0
Downlink power allocation	$\rho_A$	dB	0
	$\rho_B$	dB	0
	$\sigma$	dB	-3
	$\delta$	dB	0
$N_{oc}$ at antenna port		dBm/15 kHz	-98
Cyclic prefix			Normal
Subframe Configuration			Non-MBSFN
Precoder Update Granularity	PRB		1
	ms		1
Beamforming Pre-Coder			Annex B.4.5
Cell Specific Reference Signal			Port 0 and 1
CSI-RS Reference Signal			Port 15 and 16
CSI-RS reference signal resource configuration			0
CSI reference signal subframe configuration $l_{CSI-RS}$			2
ZP-CSI-RS configuration bitmap			0000010000000000
ZP-CSI-RS subframe configuration $l_{ZP-CSI-RS}$			2
Number of EPDCCH Sets			2 (Note 2)
EPDCCH Subframe Monitoring pattern <i>subframePatternConfig-r11</i>			1111111110 1111111101 1111111011 1111101011 (Note 3)
PDSCH TM			TM9
Note 1: The starting symbol for EPDCCH is signalled with <i>epdcch-StartSymbol-r11</i> . However, CFI is set to 1.			
Note 2: The first set is distributed transmission with PRB = {0, 49} and the second set is localized transmission with PRB = {0, 7, 14, 21, 28, 35, 42, 49}. ePDCCH is scheduled in the second set for all tests.			
Note 3: EPDCCH is scheduled in every SF. UE is required to monitor ePDCCH for UE-specific search space only in SFs configured by <i>subframePatternConfig-r11</i> . Legacy PDCCH is not scheduled.			

For the parameters specified in Table 8.10.4.2.1-1 the average probability of a missed downlink scheduling grant ( $P_{m-dsg}$ ) shall be below the specified value in Table 8.10.4.2.1-2. EPDCCH subframe monitoring is configured and the subframe monitoring requirement in EPDCCH restricted subframes is statDTX of 99.9%.

The downlink physical setup is in accordance with Annex C.3.2.

**Table 8.10.4.2.1-2: Minimum performance Localized EPDCCH with TM9 and 4Rx Antenna ports**

Test number	Bandwidth	Aggregation level	Reference Channel	OCNG Pattern	Propagation Condition	Antenna configuration and correlation Matrix	Reference value	
							Pm-dsg (%)	SNR (dB)
1	10 MHz	2 ECCE	R.57 FDD	OP.7 FDD	EVA5	2 x 4 Low	1	6.5
2	10 MHz	8 ECCE	R.58 FDD	OP.7 FDD	EVA5	2 x 4 Low	1	-1.5

#### 8.10.4.2.2 TDD

The parameters specified in Table 8.10.4.2.1 are valid for all TDD TM9 localized ePDCCH tests unless otherwise stated.

**Table 8.10.4.2.2-1: Test Parameters for Localized EPDCCH with TM9 and 4Rx**

Parameter	Unit	Value
Number of PDCCH symbols	symbols	1 (Note 1)
EPDCCH starting symbol	symbols	2 (Note 1)
PHICH duration		Normal

Unused RE-s and PRB-s			OCNG
Cell ID			0
Downlink power allocation	$\rho_A$	dB	0
	$\rho_B$	dB	0
	$\sigma$	dB	-3
	$\delta$	dB	0
$N_{oc}$ at antenna port		dBm/15 kHz	-98
Cyclic prefix			Normal
Subframe Configuration			Non-MBSFN
Precoder Update Granularity	PRB		1
	ms		1
Beamforming Pre-Coder			Annex B.4.5
Cell Specific Reference Signal			Port 0 and 1
CSI-RS Reference Signal			Port 15 and 16
CSI-RS reference signal resource configuration			0
CSI reference signal subframe configuration $l_{CSI-RS}$			0
ZP-CSI-RS configuration bitmap			0000010000000000
ZP-CSI-RS subframe configuration $l_{ZP-CSI-RS}$			0
Number of EPDCCH Sets			2 (Note 2)
EPDCCH Subframe Monitoring pattern <i>subframePatternConfig-r11</i>			1100011000 1100010000 1100011000 1100001000 1100011000 1000011000 1100011000 (Note 3)
PDSCH TM			TM9
TDD UL/DL Configuration			0
TDD Special Subframe			1 (Note 4)
Note 1: The starting symbol for EPDCCH is signalled with <i>epdcch-StartSymbol-r11</i> . However, CFI is set to 1.			
Note 2: The first set is distributed transmission with PRB = {0, 49} and the second set is localized transmission with PRB = {0, 7, 14, 21, 28, 35, 42, 49}. ePDCCH is scheduled in the second set for all tests.			
Note 3: EPDCCH is scheduled in every SF. UE is required to monitor ePDCCH for UE-specific search space only in SFs configured by <i>subframePatternConfig-r11</i> . Legacy PDCCH is not scheduled.			
Note 4: Demodulation performance is averaged over normal and special subframe.			

For the parameters specified in Table 8.10.4.2.2-1 the average probability of a missed downlink scheduling grant (Pm-dsg) shall be below the specified value in Table 8.10.4.2.2-2. EPDCCH subframe monitoring is configured and the subframe monitoring requirement in EPDCCH restricted subframes is statDTX of 99.9%.

The downlink physical setup is in accordance with Annex C.3.2.

**Table 8.10.4.2.2-2: Minimum performance Localized EPDCCH with TM9 and 4Rx Antenna ports**

Test number	Bandwidth	Aggregation level	Reference Channel	OCNG Pattern	Propagation Condition	Antenna configuration and correlation Matrix	Reference value	
							Pm-dsg (%)	SNR (dB)
1	10 MHz	2 ECCE	R.57 TDD	OP.7 TDD	EVA5	2 x 4 Low	1	6.0
2	10 MHz	8 ECCE	R.58 TDD	OP.7 TDD	EVA5	2 x 4 Low	1	-2.1

## 8.11 Demodulation (UE supporting coverage enhancement)

The requirements for UE DL Category M1 in this sub-clause are defined based on the simulation results with UE DL Category M1 unless otherwise stated.

The requirements for UE DL Category M2 in this sub-clause are defined based on the simulation results with UE DL Category M2 unless otherwise stated.

The requirements of UE DL Category M1 in this sub-clause are applicable for UE DL Category M2, UE DL Category 1bis and Category 0, as specified in the applicability rule in the sub-clause 8.1.2.8A.

The requirements of UE DL Category M2 in this sub-clause are applicable for UE DL Category 1bis and Category 0, as specified in the applicability rule in the sub-clause 8.1.2.8A.

## 8.11.1 PDSCH

### 8.11.1.1 FDD and half-duplex FDD (Fixed Reference Channel)

The parameters specified in Table 8.11.1.1-1 are valid for FDD and half-duplex FDD tests unless otherwise stated.

**Table 8.11.1.1-1: Common Test Parameters (FDD and half-duplex FDD)**

Parameter	Unit	CE Mode A	CE Mode B
Inter-TTI Distance		1	1
Number of HARQ processes per component carrier	Processes	8 or 10 (Note 2)	2
Maximum number of HARQ transmission		4	4
Redundancy version coding sequence $r_{V_{idx}}$ (Note 1)		{0, 2, 3, 1} for QPSK and 16QAM	{0,0,0,0,2,2,2,2,3,3,3,3,1,1,1,1 ...} for QPSK
Number of OFDM symbols for PDCCH per component carrier	OFDM symbols	4 for 1.4 MHz bandwidth, 3 for 3 MHz and 5 MHz bandwidths, 2 for 10 MHz, 15 MHz and 20 MHz bandwidths	4 for 1.4 MHz bandwidth, 3 for 3 MHz and 5 MHz bandwidths, 2 for 10 MHz, 15 MHz and 20 MHz bandwidths
Cyclic Prefix		Normal	Normal
Beamforming Precoder for MPDCCH		Annex B.4.4	Annex B.4.4
Precoder update granularity for MPDCCH		Frequency domain: 1 PRB Time domain: identical during the hopping period (interval-FDD for CE Mode A)	Frequency domain: 1 PRB Time domain: identical during the hopping period (interval-FDD for CE Mode B)
BL/CE DL subframe configuration (fdd-DownlinkOrTddSubframeBitmapBR)		1111111111	1111111111
Note 1: $r_{V_{idx}}$ is defined in TS 36.213 [6] Table 7.1.7.1-2.			
Note 2: For UE supporting ce-pdsch-tenProcesses-r13, the number of HARQ processes are set to 10, otherwise, it is set to 8.			

#### 8.11.1.1.1 Closed-loop spatial multiplexing performance (Cell-Specific Reference Symbols)

##### 8.11.1.1.1.1 Minimum Requirement Single-Layer Spatial Multiplexing 2 Tx Antenna Port

The requirements are specified in Table 8.11.1.1.1-2, with the addition of the parameters in Table 8.11.1.1.1-1 and the downlink physical channel setup according to Annex C.3.2. The purpose of these tests is to verify the closed loop rank-one performance with frequency selective precoding.

Table 8.11.1.1.1-1: Test Parameters for Single-Layer Spatial Multiplexing (FRC)

Parameter	Unit	Test 1	
Downlink power allocation	$\rho_A$	dB	-3
	$\rho_B$	dB	-3 (Note 1)
	$\sigma$	dB	0
	$\delta$	dB	3
$N_{oc}$ at antenna port	dBm/15kHz	-98	
Precoding granularity	PRB	6	
PMI delay (Note 2)	ms	10	
Reporting interval	ms	10	
Reporting mode		PUCCH 1-1	
Physical channel for CQI reporting		PUSCH(Note4)	
cqi-pmi-ConfigIndex		12	
CodeBookSubsetRestriction bitmap		001111	
PDSCH transmission mode		6	
Coverage enhancement mode		CE Mode A	
OFDM starting symbol (startSymbolBR)		2	
Maximum number of repetitions (mpdcch-NumRepetition)		1	
Frequency hopping (mpdcch-pdsch-HoppingConfig)		Disabled	
MPDCCH transmission duration	ms	1	
Starting subframe configuration for MPDCCH (mpdcch_startSF_UESS)		1	
Narrowband for MPDCCH (mpdcch_Narrowband)		1	
Note 1: $P_B = 1$ .			
Note 2: If the UE reports in an available uplink reporting instance at subframe SF#n based on PMI estimation at a downlink SF not later than SF#(n-4), This reported PMI cannot be applied at the eNB downlink before SF#(n+4).			
Note 3: For each test, DC subcarrier puncturing shall be considered.			
Note 4: To avoid collisions between CQI reports and HARQ-ACK it is necessary to report both on PUSCH instead of PUCCH. PDCCH DCI format 6-0A shall be transmitted in downlink SF#1 to allow periodic CQI to multiplex with the HARQ-ACK on PUSCH in uplink subframe SF#5.			
Note 5: If not otherwise stated, the values in this table refer to parameters in TS 36.211 [4] or/and TS 36.213 [6] as appropriate.			

Table 8.11.1.1.1-2: Minimum performance Single-Layer Spatial Multiplexing (FRC)

Test number	Bandwidth and MCS	Reference Channel	OCNG Pattern	Propagation Condition	Correlation Matrix and Antenna Configuration	Reference value	
						Fraction of Maximum Throughput (%)	SNR (dB)
1	10MHz 16QAM 1/2	R.79 FDD	OP.2 FDD	EPA5	2x1 Low	70%	8.6



### 8.11.1.1.1.2 Minimum Requirement Single-Layer Spatial Multiplexing 2 Tx Antenna Port with CRS assistance information

The requirements are specified in Table 8.11.1.1.1.2-2, with the addition of parameters in Table 8.11.1.1.2-1. In Table 8.11.1.1.2-1, Cell 1 is the serving cell, and Cell 2 and Cell 3 are the aggressor cells. The downlink physical channel setup is according to Annex C.3.2 for each of Cell 1, Cell 2 and Cell 3, respectively. The CRS assistance information [7] is provided to the UE and includes information on Cell 2 and Cell 3.

The purpose of the test is to verify the closed loop single-layer spatial multiplexing TM6 performance under assumption that UE applies CRS interference mitigation in the scenario with 2 CRS antenna ports in the serving and aggressor cells.

**Table 8.11.1.1.2-1: Test Parameters**

Parameter	Unit	Cell 1	Cell 2	Cell 3	
Downlink power allocation	$\rho_A$	dB	-3	-3	-3
	$\rho_B$	dB	-3 (Note 1)	-3 (Note 1)	-3 (Note 1)
	$\sigma$	dB	0	0	0
$N_{oc}$ at antenna port	dBm/15kHz	-98	N/A	N/A	
$\bar{E}_s/N_{oc}$	dB	N/A	11.75	5.69	
$BW_{channel}$	MHz	10	10	10	
Cyclic prefix		Normal	Normal	Normal	
Subframe Configuration		Non-MBSFN	Non-MBSFN	Non-MBSFN	
Cell ID		0	1	6	
Cell-specific reference signals		Antenna ports 0,1			
Number of control OFDM symbols (CFI)		2	2	2	
PDSCH transmission mode		6	N/A	N/A	
Coverage enhancement mode		CE Mode A	N/A	N/A	
OFDM starting symbol (startSymbolBR)		2	N/A	N/A	
Maximum number of repetitions (mpdcch-NumRepetition)		1	N/A	N/A	
Frequency hopping (mpdcch-pdsch-HoppingConfig)		Disabled	N/A	N/A	
MPDCCH transmission duration	ms	1	N/A	N/A	
Starting subframe configuration for MPDCCH (mpdcch_startSF_UESS)		1	N/A	N/A	
Precoding granularity	PRB	6	N/A	N/A	
PMI delay (Note 2)	ms	10	N/A	N/A	
Reporting interval	ms	10	N/A	N/A	
Reporting mode		PUCCH 1-1	N/A	N/A	
Physical channel for CQI reporting		PUSCH(Note4)			
CodeBookSubsetRestriction bitmap		001111	N/A	N/A	
Time offset relative to Cell 1	$\mu$ s	N/A	3	-1	
Frequency shift relative to Cell 1	Hz	N/A	300	-100	
Interference model		N/A	As specified in clause B.5.3	As specified in clause B.5.3	
Probability of occurrence of transmission in interference cells	%	N/A	10	10	
Probability of occurrence of transmission rank in interfering cells	Rank 1	%	N/A	80	80
	Rank 2	%	N/A	20	20

Note 1:	$P_B = 1$ .
Note 2:	If the UE reports in an available uplink reporting instance at subframe SF #n based on PMI estimation at a downlink SF not later than SF#(n-4). This reported PMI cannot be applied at the eNB downlink before SF#(n+4).
Note 3:	For each test, DC subcarrier puncturing shall be considered.
Note 4:	To avoid collisions between CQI reports and HARQ-ACK it is necessary to report both on PUSCH instead of PUCCH. PDCCH DCI format 6-0A shall be transmitted in downlink SF#1 to allow periodic CQI to multiplex with the HARQ-ACK on PUSCH in uplink subframe SF#5.

Table 8.11.1.1.2-2: Minimum performance for PDSCH

Test Number	Reference Channel	OCNG Pattern			Propagation Conditions (Note1)			Correlation Matrix and Antenna Configuration (Note 2)	Reference Value		UE Category
		Cell 1	Cell 2	Cell 3	Cell 1	Cell 2	Cell 3		Fraction of Maximum Throughput (%)	SNR (dB) (Note 3)	
1	R.79 FDD	OP.1 FDD	N/A	N/A	EPA5	EPA5	EPA5	2x1 Low	70	12.5	M2

Note 1: The propagation conditions for Cell 1, Cell 2 and Cell 3 are statistically independent.  
Note 2: The correlation matrix and antenna configuration apply for Cell 1, Cell 2 and Cell 3.  
Note 3: SNR corresponds to  $\bar{E}_s/N_{oc}$  of cell 1.

#### 8.11.1.1.3 Minimum Requirement Single-Layer Spatial Multiplexing 4 Tx Antenna Port with CRS assistance information

The requirements are specified in Table 8.11.1.1.3-2, with the addition of parameters in Table 8.11.1.1.3-1. In Table 8.11.1.1.3-1, Cell 1 is the serving cell, and Cell 2 and Cell 3 are the aggressor cells. The downlink physical channel setup is according to Annex C.3.2 for each of Cell 1, Cell 2 and Cell 3, respectively. The CRS assistance information [7] is provided to the UE and includes information on Cell 2 and Cell 3.

The purpose of the test is to verify the closed loop single-layer spatial multiplexing TM6 performance under assumption that UE applies CRS interference mitigation in the scenario with 4 CRS antenna ports in the serving and aggressor cells.

Table 8.11.1.1.3-1: Test Parameters

Parameter	Unit	Cell 1	Cell 2	Cell 3	
Downlink power allocation	$\rho_A$	dB	-6	-6	-6
	$\rho_B$	dB	-6 (Note 1)	-6 (Note 1)	-6 (Note 1)
	$\sigma$	dB	3	3	3
$N_{oc}$ at antenna port	dBm/15kHz	-98	N/A	N/A	
$\bar{E}_s/N_{oc}$	dB	N/A	10.45	4.6	
$BW_{Channel}$	MHz	10	10	10	
Cyclic prefix		Normal	Normal	Normal	
Subframe Configuration		Non-MBSFN	Non-MBSFN	Non-MBSFN	
Cell ID		0	1	6	
Cell-specific reference signals		Antenna ports 0,1,2,3			
Number of control OFDM symbols (CFI)		2	2	2	
PDSCH transmission mode		6	N/A	N/A	
Coverage enhancement mode		CE Mode A	N/A	N/A	
OFDM starting symbol (startSymbolBR)		2	N/A	N/A	
Maximum number of repetitions (mpdcch-NumRepetition)		1	N/A	N/A	
Frequency hopping (mpdcch-pdsch-HoppingConfig)		Disabled	N/A	N/A	
MPDCCH transmission duration	ms	1	N/A	N/A	

Starting subframe configuration for MPDCCH (mpdcch_startSF_UESS)		1	N/A	N/A	
Precoding granularity	PRB	6	N/A	N/A	
PMI delay (Note 2)	ms	10	N/A	N/A	
Reporting interval	ms	10	N/A	N/A	
Reporting mode		PUCCH 1-1	N/A	N/A	
Physical channel for CQI reporting		PUSCH(Note4)			
CodeBookSubsetRestriction bitmap		001111	N/A	N/A	
Time offset relative to Cell 1	$\mu$ s	N/A	3	-1	
Frequency shift relative to Cell 1	Hz	N/A	300	-100	
Interference model		N/A	As specified in clause B.5.3	As specified in clause B.5.3	
Probability of occurrence of transmission in interference cells	%	N/A	20	20	
Probability of occurrence of transmission rank in interfering cells	Rank 1	%	N/A	80	80
	Rank 2	%	N/A	20	20
<p>Note 1: <math>P_{ij} = 1</math>.</p> <p>Note 2: If the UE reports in an available uplink reporting instance at subframe SF #n based on PMI estimation at a downlink SF not later than SF#(n-4). This reported PMI cannot be applied at the eNB downlink before SF#(n+4).</p> <p>Note 3: For each test, DC subcarrier puncturing shall be considered.</p> <p>Note 4: To avoid collisions between CQI reports and HARQ-ACK it is necessary to report both on PUSCH instead of PUCCH. PDCCH DCI format 6-0A shall be transmitted in downlink SF#1 to allow periodic CQI to multiplex with the HARQ-ACK on PUSCH in uplink subframe SF#5.</p>					

Table 8.11.1.1.1.3-2: Minimum performance for PDSCH

Test Number	Reference Channel	OCNG Pattern			Propagation Conditions (Note1)			Correlation Matrix and Antenna Configuration (Note 2)	Reference Value		UE Category
		Cell 1	Cell 2	Cell 3	Cell 1	Cell 2	Cell 3		Fraction of Maximum Throughput (%)	SNR (dB) (Note 3)	
1	R.95 FDD	OP.1 FDD	N/A	N/A	EPA5	EPA5	EPA5	4x1 Low	70	11.4	M2
<p>Note 1: The propagation conditions for Cell 1, Cell 2 and Cell 3 are statistically independent.</p> <p>Note 2: The correlation matrix and antenna configuration apply for Cell 1, Cell 2 and Cell 3.</p> <p>Note 3: SNR corresponds to <math>\bar{E}_s/N_{oc}</math> of cell 1.</p>											

### 8.11.1.1.2 Closed-loop spatial multiplexing performance (User-Specific Reference Symbols)

#### 8.11.1.1.2.1 Single-layer Spatial Multiplexing

For single-layer transmission on antenna ports 7 or 8 upon detection of a MPDCCH with DCI format 6-1A, the requirements are specified in Table 8.11.1.1.2.1-2 with the addition of the parameters in Table 8.11.1.1.2.1-1 and the downlink physical channel setup according to Annex C.3.2. The purpose of these tests is to verify rank-1 performance on one of the antenna ports 7 or 8.

Table 8.11.1.1.2.1-1: Test Parameters for Testing CDM-multiplexed DM RS (single layer)

parameter	Unit	Test 1	Test 2	Test 3	
Downlink power allocation	$\rho_A$	dB	0	0	0
	$\rho_B$	dB	0 (Note 1)	0 (Note 1)	0 (Note 1)
	$\sigma$	dB	-3	-3	-3
	$\delta$	dB	0	0	0
Beamforming model		Annex B.4.1	Annex B.4.1	Annex B.4.1	
Cell-specific reference signals		Antenna ports 0,1	Antenna ports 0,1	Antenna ports 0,1	
$N_{oc}$ at antenna port	dBm/15kHz	-98 (Note 6)	-98 (Note 6)	-98 (Note 6)	
Symbols for unused PRBs		OCNG (Note 3)	OCNG (Note 3)	OCNG (Note 3)	
Number of allocated resource blocks (Note 2)	PRB	6	6	6	
Simultaneous transmission		No	No	No	
PDSCH transmission mode		9	9	9	
Coverage enhancement mode		CE Mode A	CE Mode A	CE Mode A	
OFDM starting symbol (startSymbolBR)		2	2	2	
Maximum number of repetitions for PDSCH ( $pdsch\_maxNumRepetitionCEmodeA$ )		16	16	Not configured	
PDSCH repetition number		8	4	2	
Frequency hopping (mpdcch-pdsch-HoppingConfig)		Enabled	Enabled	Enabled	
Frequency hopping offset (mpdcch-pdsch-HoppingOffset)		1	1	1	
Frequency hopping interval (interval-FDD)	ms	8	2	1	
MPDCCH transmission duration (mpdcch-NumRepetition)	ms	8	2	1	
MPDCCH repetition number		8	2	1	
Number of narrowbands for frequency hopping (mpdcch-pdsch-HoppingNB)		2	2	2	
Starting subframe configuration for MPDCCH (mpdcch_startSF_U ESS)		4	8	10	
Narrowband for MPDCCH (mpdcch_Narrowband)		7	7	7	
MPDCCH aggregation level		24	24	24	
<p>Note 1: <math>P_B = 1</math>.</p> <p>Note 2: The modulation symbols of the signal under test are mapped onto antenna port 7 or 8.</p> <p>Note 3: These physical resource blocks are assigned to an arbitrary number of virtual UEs with one PDSCH per virtual UE; the data transmitted over the OCNG PDSCHs shall be uncorrelated pseudo random data, which is QPSK modulated.</p> <p>Note 4: For each test, DC subcarrier puncturing shall be considered.</p> <p>Note 5: If not otherwise stated, the values in this table refer to parameters in TS 36.211 [4] or/and TS 36.213 [6] as appropriate.</p>					

**Table 8.11.1.1.2.1-2: Minimum performance for CDM-multiplexed DM RS (FRC)**

Test number	Bandwidth and MCS	Reference Channel	OCNG Pattern	Propagation Condition	Correlation Matrix and Antenna Configuration	Reference value		UE Category
						Fraction of Maximum Throughput (%)	SNR (dB)	
1	10MHz QPSK 1/3	R.80 FDD	OP.2 FDD	EPA5	2x1 Low	70	-2.0	M1
2	10MHz QPSK 1/3	R.80-1 FDD	OP.2 FDD	EPA5	2x2 Low	70	-4.0	≥1
3	10MHz QPSK 1/3	R.80-2 FDD	OP.2 FDD	EPA5	2x4 Low	70	-4.0	≥1

8.11.1.1.2.2 (Void)

8.11.1.1.2.3 (Void)

8.11.1.1.3 Transmit diversity performance (Cell-Specific Reference Symbols)

8.11.1.1.3.1 Minimum Requirement 2 Tx Antenna Port supporting narrowband transmission

The requirements are specified in Table 8.11.1.1.3.1-2, with the addition of the parameters in Table 8.11.1.1.3.1-1 and Table 8.11.1.1.3.1-1a, and the downlink physical channel setup according to Annex C.3.2. The purpose is to verify the performance of transmit diversity (SFBC) with 2 transmitter antennas.

Table 8.11.1.1.3.1-1: Test Parameters for Transmit diversity performance (FRC)

Parameter	Unit	Test 1 (Note 3)	Test 2 (Note 3)	Test 2a (Note 3)	Test 3 (Note 3)	Test 4 (Note 3)
Downlink power allocation	$\rho_A$	dB	-3	-3	-3	-3
	$\rho_B$	dB	-3 (Note 1)	-3 (Note 1)	-3 (Note 1)	-3 (Note 1)
	$\sigma$	dB	0	0	0	0
	$\delta$	dB	3	3	3	3
$N_{oc}$ at antenna port	dBm/15kHz	-98	-98	-98	-98	-98
Coverage enhancement mode		CE Mode B	CE Mode A	CE Mode A	CE Mode B	CE Mode B
PDSCH transmission mode		2	2	2	2	2
OFDM starting symbol (startSymbolBR)		2	2	2	2	2
Maximum number of repetitions (for PDSCH ( $pdsch-maxNumRepetitionCEmodeA/pdsch-maxNumRepetitionCEmodeB$ ))		Not configured	Not configured	Not configured	Not configured	Not configured
PDSCH repetition number		64	1	1	32	16
Frequency hopping (mpdcch-pdsch-HoppingConfig)		Enabled	Disabled	Disabled	Enabled	Enabled
Frequency hopping offset (mpdcch-pdsch-HoppingOffset)		1	N/A	N/A	1	1
Frequency hopping interval (interval-FDD)	ms	16	N/A	N/A	8	4
MPDCCH transmission duration (mPDCCH-NumRepetition)	ms	64	1	1	32	8
MPDCCH repetition number		64	1	1	32	8
Number of narrowbands for frequency hopping (mpdcch-pdsch-HoppingNB)		4	N/A	N/A	4	4
Starting subframe configuration for MPDCCH (mpdcch_startSF_U ESS)		2.5	1	1	2.5	4
Narrowband for MPDCCH (mpdcch_Narrowband)		7	0	0	7	7
MPDCCH aggregation level		24	8	8	24	24
CRS muting outside UE RF bandwidth (crs-IntfMitigEnabled)		Disabled	Disabled	Enabled	Disabled	Disabled
Number of PRBs for CRS transmission (crs-IntfMitigNumPRBs)		N/A	N/A	6	N/A	N/A
Note 1: $P_B = 1$ .						
Note 2: For each test, DC subcarrier puncturing shall be considered.						
Note 3: Test 1, test 3 and test 4 are applicable for UE supporting CE Mode B. Test 2 is applicable for UE not supporting CE Mode B. Test 2a is applicable for UE not supporting CE Mode B and UE capable of ce-CRS-IntfMitig.						
Note 4: If not otherwise stated, the values in this table refer to parameters in TS 36.211 [4] or/and TS 36.213 [6] as appropriate.						

Table 8.11.1.1.3.1-1a: Test Parameters for Transmit diversity performance (FRC)

Parameter		Unit	Test 5	Test 6
Downlink power allocation	$\rho_A$	dB	-3	-3
	$\rho_B$	dB	-3 (Note 1)	-3 (Note 1)
	$\sigma$	dB	0	0
	$\delta$	dB	3	3
$N_{oc}$ at antenna port		dBm/15 kHz	-98	-98
Coverage enhancement mode			CE Mode A	CE Mode A
PDSCH transmission mode			2	2
OFDM starting symbol (startSymbolBR)			2	2
Maximum number of repetitions (for PDSCH ( $pdsch-maxNumRepetitionCEmodeA/pdsch-maxNumRepetitionCEmodeB$ ))			Not configured	Not configured
PDSCH repetition number			1	1
Frequency hopping (mpdcch-pdsch-HoppingConfig)			Disabled	Disabled
Frequency hopping offset (mpdcch-pdsch-HoppingOffset)			N/A	N/A
Frequency hopping interval (interval-FDD)		ms	N/A	N/A
MPDCCH transmission duration (mpdcch-NumRepetition)		ms	4	1
MPDCCH repetition number			4	1
Number of narrowbands for frequency hopping (mpdcch-pdsch-HoppingNB)			N/A	N/A
Starting subframe configuration for MPDCCH (mpdcch_startSF_UESS)			1	1
Narrowband for MPDCCH (mpdcch_Narrowband)			0	0
MPDCCH aggregation level			8	8
CRS muting outside UE RF bandwidth (crs-IntfMitigEnabled)			Disabled	Disabled
Activation of 64QAM for non-repeated PDSCH in CE Mode A (ce-PDSCH-64QAM-Config)			Disabled	Enabled
Note 1: $P_B = 1$ .				
Note 2: For each test, DC subcarrier puncturing shall be considered.				
Note 3: If not otherwise stated, the values in this table refer to parameters in TS 36.211 [4] or/and TS 36.213 [6] as appropriate.				
Note 4: Test 6 is applicable for UE capable of ce-PDSCH-64QAM.				

Table 8.11.1.1.3.1-2: Minimum performance Transmit Diversity (FRC)

Test number	Bandwidth and MCS	Reference Channel	OCNG Pattern	Propagation Condition	Correlation Matrix and Antenna Configuration	Reference value		UE Category
						Fraction of Maximum Throughput (%)	SNR (dB)	
1	10MHz QPSK 1/10	R.81 FDD	OP.2 FDD	ETU1	2x1 Low	70	-13.5	M1
2	10MHz 16QAM 1/2	R.79 FDD	OP.2 FDD	EPA5	2x1 Low	70	9.4	M1
2a	10MHz 16QAM 1/2	R.79 FDD	OP.2 FDD	EPA5	2x1 Low	70	9.6	M1
3	10MHz QPSK 1/10	R.81-1 FDD	OP.2 FDD	ETU1	2x2 Low	70	-13.3	$\geq 1$
4	10MHz QPSK 1/10	R.81-2 FDD	OP.2 FDD	ETU1	2x4 Low	70	-13.3	$\geq 1$
5	10MHz QPSK 1/3	R.103 FDD	OP.2 FDD	EPA200	2x1 Low	70	3.8	M1
6	10MHz 64QAM 0.4	R.104 FDD	OP.2 FDD	EPA5	2x1 Low	70	12.9	M1

## 8.11.1.1.3.2 Minimum Requirement 2 Tx Antenna Port supporting wideband transmission

The requirements are specified in Table 8.11.1.1.3.2-2, with the addition of the parameters in Table 8.11.1.1.3.2-1 and the downlink physical channel setup according to Annex C.3.2. The purpose is to verify the performance of transmit diversity (SFBC) with 2 transmitter antennas.

Table 8.11.1.1.3.2-1: Test Parameters for Transmit diversity performance (FRC)

Parameter	Unit	Test 1	Test 2	Test 2a (Note 4)	Test 3	Test 4
Downlink power allocation	$\rho_A$	dB	-3	-3	-3	-3
	$\rho_B$	dB	-3 (Note 1)	-3 (Note 1)	-3 (Note 1)	-3 (Note 1)
	$\sigma$	dB	0	0	0	0
	$\delta$	dB	3	3	3	3



$N_{oc}$ at antenna port	$\text{dBm}/15\text{kHz}$ $z$	-98	-98	-98	-98	-98
Coverage enhancement mode		CE Mode A	CE Mode B	CE Mode B	CE Mode A	CE Mode A
PDSCH transmission mode		2	2	2	2	2
OFDM starting symbol (startSymbolBR)		2	2	2	2	2
Maximum number of repetitions for PDSCH (pdsch-maxNumRepetitionCEmodeA/pdsch-maxNumRepetitionCEmodeB)		Not configured	Not configured	Not configured	Not configured	Not configured
PDSCH repetition number		8	32	32	4	2
Frequency hopping (mpdcch-pdsch-HoppingConfig)		Enabled	Enabled	Enabled	Disabled	Disabled
Frequency hopping offset (mpdcch-pdsch-HoppingOffset)		5	5	5	N/A	N/A
Frequency hopping interval (interval-FDD)	ms	4	16	16	N/A	N/A
Maximum number of MPDCCH repetitions (mpdcch-NumRepetition)		16	64	64	8	2
MPDCCH transmission duration	ms	16	64	64	8	2
Number of narrowbands for frequency hopping (mpdcch-pdsch-HoppingNB)		2	2	2	N/A	N/A
Starting subframe configuration for MPDCCH (mpdcch_startSF_UESS)		2	2	2	2.5	5
Narrowband for MPDCCH (mpdcch_Narrowband)		0	0	0	0	0
MPDCCH aggregation level		24	24	24	24	24
CRS muting outside UE RF bandwidth (crs-IntfMitigEnabled)		Disabled	Disabled	Enabled	Disabled	Disabled
Number of PRBs for CRS transmission (crs-IntfMitigNumPRBs)		N/A	N/A	24	N/A	N/A
<p>Note 1: <math>P_B = 1</math>.</p> <p>Note 2: For each test, DC subcarrier puncturing shall be considered.</p> <p>Note 3: If not otherwise stated, the values in this table refer to parameters in TS 36.211 [4] or/and TS 36.213 [6] as appropriate.</p> <p>Note 4: Test 2a is applicable for UE supporting CE Mode B and UE capable of ce-CRS-IntfMitig.</p>						

Table 8.11.1.1.3.2-2: Minimum performance Transmit Diversity (FRC)

Test number	Bandwidth and MCS	Reference Channel	OCNG Pattern	Propagation Condition	Correlation Matrix and Antenna Configuration	Reference value		UE Category
						Fraction of Maximum Throughput (%)	SNR (dB)	
1	10MHz QPSK 1/3	R.90 FDD	OP.2 FDD	EPA5	2x1 Low	70	-5.4	M2
2	10MHz QPSK 1/10	R.91 FDD	OP.2 FDD	ETU1	2x1 Low	70	-13.1	M2
2a	10MHz QPSK 1/10	R.91 FDD	OP.2 FDD	ETU1	2x1 Low	70	-12.9	M2
3	10MHz QPSK 1/2	R.92-1 FDD	OP.2 FDD	EPA5	2x2 Low	70	-4.8	$\geq 1$
4	10MHz QPSK 1/2	R.92-2 FDD	OP.2 FDD	EPA5	2x4 Low	70	-4.9	$\geq 1$

## 8.11.1.2 TDD (Fixed Reference Channel)

The parameters specified in Table 8.11.1.2-1 are valid for all TDD tests unless otherwise stated.

Table 8.11.1.2-1: Common Test Parameters (TDD)

Parameter	Unit	CE Mode A	CE Mode B
Uplink downlink configuration (Note 1)			1
Special subframe configuration (Note 2)			4
Cyclic prefix		Normal	Normal
Cell ID		0	0
Inter-TTI Distance		1	1
Number of HARQ processes per component carrier	Processes	7	2
Maximum number of HARQ transmission		4	4
Redundancy version coding sequence $r_{V_{idx}}$ (Note 3)		{0, 2, 3, 1} for QPSK and 16QAM	{0,0,0,0,0,0,0,0,0,2,2,2,2,2,2,2,2,2,3,3,3,3,3,3,3,3,3,3,1,1,1,1,1,1,1,1,1,1} for QPSK
Number of OFDM symbols for PDCCH per component carrier	OFDM symbols	4 for 1.4 MHz bandwidth, 3 for 3 MHz and 5 MHz bandwidths, 2 for 10 MHz, 15 MHz and 20 MHz bandwidths	4 for 1.4 MHz bandwidth, 3 for 3 MHz and 5 MHz bandwidths, 2 for 10 MHz, 15 MHz and 20 MHz bandwidths
ACK/NACK feedback mode		Multiplexing	Multiplexing
Beamforming Precoder for MPDCCH		Annex B.4.4	Annex B.4.4
Precoder update granularity for MPDCCH		Frequency domain: 1 PRB Time domain: identical during the hopping period (interval-TDD for CE Mode A)	Frequency domain: 1 PRB Time domain: identical during the hopping period (interval-TDD for CE Mode B)
BL/CE DL subframe configuration (fdd-DownlinkOrTddSubframeBitmapBR)		1011110111	1011110111
Note 1: as specified in Table 4.2-2 in TS 36.211 [4]. Note 2: as specified in Table 4.2-1 in TS 36.211 [4]. Note 3: $r_{V_{idx}}$ is defined in TS 36.213 [6] Table 7.1.7.1-2.			

## 8.11.1.2.1 Closed-loop spatial multiplexing performance (Cell-Specific Reference Symbols)

## 8.11.1.2.1.1 Minimum Requirement Single-Layer Spatial Multiplexing 2 Tx Antenna Port

The requirements are specified in Table 8.11.1.2.1.1-2, with the addition of the parameters in Table 8.11.1.2.1.1-1 and the downlink physical channel setup according to Annex C.3.2. The purpose of these tests is to verify the closed loop rank-one performance with frequency selective precoding.

Table 8.11.1.2.1.1-1: Test Parameters for Single-Layer Spatial Multiplexing (FRC)

Parameter	Unit	Test 1	
Downlink power allocation	$\rho_A$	dB	-3
	$\rho_B$	dB	-3 (Note 1)
	$\sigma$	dB	0
	$\delta$	dB	3
$N_{oc}$ at antenna port	dBm/15kHz	-98	
Precoding granularity	PRB	6	
PMI delay (Note 2)	ms	10 or 11	
Reporting interval	ms	5	
Reporting mode		PUCCH 1-1	
cqi-pmi-ConfigIndex		4	
CodeBookSubsetRestriction bitmap		001111	
ACK/NACK feedback mode		Multiplexing	
Physical channel for CQI reporting		PUSCH (Note 3)	
PDSCH transmission mode		6	
Coverage enhancement mode		CE Mode A	
OFDM starting symbol (startSymbolBR)		2	
Maximum number of repetitions (mpdcch-NumRepetition)		1	
Frequency hopping (mpdcch-pdsch-HoppingConfig)		Disabled	
MPDCCH transmission duration	ms	1	
Starting subframe configuration for MPDCCH (mpdcch_startSF_U ESS)		1	
Narrowband for MPDCCH (mpdcch_Narrowband)		1	
<p>Note 1: <math>P_B = 1</math>.</p> <p>Note 2: If the UE reports in an available uplink reporting instance at subframe SF#n based on PMI estimation at a downlink SF not later than SF#(n-4), this reported PMI cannot be applied at the eNB downlink before SF#(n+4).</p> <p>Note 3: To avoid collisions between CQI reports and HARQ-ACK it is necessary to report both on PUSCH instead of PUCCH. MPDCCH DCI format 6-0A shall be transmitted in downlink SF#4 and #9 to allow periodic CQI to multiplex with the HARQ-ACK on PUSCH in uplink subframe SF#8 and #3.</p> <p>Note 4: For each test, DC subcarrier puncturing shall be considered.</p> <p>Note 5: If not otherwise stated, the values in this table refer to parameters in TS 36.211 [4] or/and TS 36.213 [6] as appropriate.</p>			

Table 8.11.1.2.1.1-2: Minimum performance Single-Layer Spatial Multiplexing (FRC)

Test number	Bandwidth and MCS	Reference Channel	OCNG Pattern	Propagation Condition	Correlation Matrix and Antenna Configuration	Reference value	
						Fraction of Maximum Throughput (%)	SNR (dB)
1	10MHz 16QAM 1/2	R.79 TDD	OP.2 TDD	EPA5	2x1 Low	70%	11.4

#### 8.11.1.2.1.2 Minimum Requirement Single-Layer Spatial Multiplexing 2 Tx Antenna Port with CRS assistance information

The requirements are specified in Table 8.11.1.2.1.2-2, with the addition of parameters in Table 8.11.1.2.1.2-1. In Table 8.11.1.2.1.2-1, Cell 1 is the serving cell, and Cell 2 and Cell 3 are the aggressor cells. The downlink physical channel setup is according to Annex C.3.2 for each of Cell 1, Cell 2 and Cell 3, respectively. The CRS assistance information [7] is provided to the UE and includes information on Cell 2 and Cell 3.

The purpose of the test is to verify the closed loop single-layer spatial multiplexing TM6 performance under assumption that UE applies CRS interference mitigation in the scenario with 2 CRS antenna ports in the serving and aggressor cells.

Table 8.11.1.2.1.2-1: Test Parameters

Parameter	Unit	Cell 1 (Option 1)	Cell 2	Cell 3	
Uplink downlink Configuration		1	1	1	
Special subframe configuration		4	4	4	
Downlink power allocation	$\rho_A$	dB	-3	-3	-3
	$\rho_B$	dB	-3 (Note 1)	-3 (Note 1)	-3 (Note 1)
	$\sigma$	dB	0	0	0
$N_{oc}$ at antenna port	dBm/15kHz	-98	N/A	N/A	
$\bar{E}_s/N_{oc}$	dB	N/A	11.75	5.69	
$BW_{channel}$	MHz	10	10	10	
Cyclic prefix		Normal	Normal	Normal	
Subframe Configuration		Non-MBSFN	Non-MBSFN	Non-MBSFN	
Cell ID		0	1	6	
Cell-specific reference signals		Antenna ports 0,1			
Number of control OFDM symbols (CFI)		2	2	2	
PDSCH transmission mode		6	N/A	N/A	
Coverage enhancement mode		CE Mode A	N/A	N/A	
OFDM starting symbol (startSymbolBR)		2	N/A	N/A	
Maximum number of repetitions (mpdcch-NumRepetition)		1	N/A	N/A	
Frequency hopping (mpdcch-pdsch-HoppingConfig)		Disabled	N/A	N/A	
Frequency hopping offset (mpdcch-pdsch-HoppingOffset)		N/A	N/A	N/A	
Frequency hopping interval (interval-TDD)	ms	N/A	N/A	N/A	
MPDCCH transmission duration	ms	1	N/A	N/A	
Starting subframe configuration for MPDCCH (mpdcch_startSF_U ESS)		1	N/A	N/A	
Precoding granularity	PRB	6	N/A	N/A	
PMI delay (Note 2)	ms	10 or 11	N/A	N/A	
Reporting interval	ms	5	N/A	N/A	
Reporting mode		PUCCH 1-1	N/A	N/A	

Physical channel for CQI reporting		PUSCH(Note4)		
CodeBookSubsetRestriction bitmap		001111	N/A	N/A
Time Offset relative to Cell 1	$\mu\text{s}$	N/A	3	-1
Frequency shift relative to Cell 1	Hz	N/A	300	-100
Interference model		N/A	As specified in clause B.5.3	As specified in clause B.5.3
Probability of occurrence of transmission in interference cells	%	N/A	10	10
Probability of occurrence of transmission rank in interfering cells	Rank 1	%	N/A	80
	Rank 2	%	N/A	20
<p>Note 1: <math>P_B = 1</math>.</p> <p>Note 2: If the UE reports in an available uplink reporting instance at subframe SF #n based on PMI estimation at a downlink SF not later than SF #(n-4). This reported PMI cannot be applied at the eNB downlink before SF #(n+4).</p> <p>Note 3: For each test, DC subcarrier puncturing shall be considered.</p> <p>Note 4: To avoid collisions between CQI reports and HARQ-ACK it is necessary to report both on PUSCH instead of PUCCH. MPDCCH DCI format 6-0A shall be transmitted in downlink SF#4 and #9 to allow periodic CQI to multiplex with the HARQACK on PUSCH in uplink subframe SF#8 and #3.</p>				

Table 8.11.1.2.1.2-2: Minimum performance for PDSCH

Test Number	Reference Channel	OCNG Pattern			Propagation Conditions (Note1)			Correlation Matrix and Antenna Configuration (Note 2)	Reference Value		UE Category
		Cell 1	Cell 2	Cell 3	Cell 1	Cell 2	Cell 3		Fraction of Maximum Throughput (%)	SNR (dB) (Note 3)	
1	R.79 TDD	OP.1 TDD	N/A	N/A	EPA5	EPA5	EPA5	2x1 Low	70	11.5	M2
<p>Note 1: The propagation conditions for Cell 1, Cell 2 and Cell 3 are statistically independent.</p> <p>Note 2: The correlation matrix and antenna configuration apply for Cell 1, Cell 2 and Cell 3.</p> <p>Note 3: SNR corresponds to <math>\bar{E}_s/N_{oc}</math> of cell 1.</p>											

#### 8.11.1.2.1.3 Minimum Requirement Single-Layer Spatial Multiplexing 4 Tx Antenna Port with CRS assistance information

The requirements are specified in Table 8.11.1.2.1.3-2, with the addition of parameters in Table 8.11.1.2.1.3-1. In Table 8.11.1.2.1.3-1, Cell 1 is the serving cell, and Cell 2 and Cell 3 are the aggressor cells. The downlink physical channel setup is according to Annex C.3.2 for each of Cell 1, Cell 2 and Cell 3, respectively. The CRS assistance information [7] is provided to the UE and includes information on Cell 2 and Cell 3.

The purpose of the test is to verify the closed loop single-layer spatial multiplexing TM6 performance under assumption that UE applies CRS interference mitigation in the scenario with 4 CRS antenna ports in the serving and aggressor cells.

Table 8.11.1.2.1.3-1: Test Parameters

Parameter	Unit	Cell 1	Cell 2	Cell 3
Uplink downlink Configuration		1	1	1
Special subframe configuration		4	4	4
Downlink power allocation	$\rho_A$	dB	-6	-6
	$\rho_B$	dB	-6 (Note 1)	-6 (Note 1)
	$\sigma$	dB	3	3
$N_{oc}$ at antenna port	dBm/15kHz	-98	N/A	N/A

$\bar{E}_s/N_{oc}$	dB	N/A	10.45	4.6	
BW <sub>channel</sub>	MHz	10	10	10	
Cyclic prefix		Normal	Normal	Normal	
Subframe Configuration		Non-MBSFN	Non-MBSFN	Non-MBSFN	
Cell ID		0	1	6	
Cell-specific reference signals		Antenna ports 0,1,2,3			
Number of control OFDM symbols (CFI)		2	2	2	
PDSCH transmission mode		6	N/A	N/A	
Coverage enhancement mode		CE Mode A	N/A	N/A	
OFDM starting symbol (startSymbolBR)		2	N/A	N/A	
Maximum number of repetitions (mpdcch-NumRepetition)		1	N/A	N/A	
Frequency hopping (mpdcch-pdsch-HoppingConfig)		Disabled	N/A	N/A	
MPDCCH transmission duration	ms	1	N/A	N/A	
Starting subframe configuration for MPDCCH (mpdcch_startSF_UESS)		1	N/A	N/A	
Precoding granularity	PRB	6	N/A	N/A	
PMI delay (Note 2)	ms	10 or 11	N/A	N/A	
Reporting interval	ms	5	N/A	N/A	
Reporting mode		PUCCH 1-1	N/A	N/A	
Physical channel for CQI reporting		PUSCH(Note4)			
CodeBookSubsetRestriction bitmap		001111	N/A	N/A	
Time Offset relative to Cell 1	μs	N/A	3	-1	
Frequency shift relative to Cell 1	Hz	N/A	300	-100	
Interference model		N/A	As specified in clause B.5.3	As specified in clause B.5.3	
Probability of occurrence of transmission in interference cells	%	N/A	20	20	
Probability of occurrence of transmission rank in interfering cells	Rank 1	%	N/A	80	80
	Rank 2	%	N/A	20	20
<p>Note 1: <math>P_B = 1</math>.</p> <p>Note 2: If the UE reports in an available uplink reporting instance at subframe SF #n based on PMI estimation at a downlink SF not later than SF#(n-4). This reported PMI cannot be applied at the eNB downlink before SF#(n+4).</p> <p>Note 3: For each test, DC subcarrier puncturing shall be considered.</p> <p>Note 4: To avoid collisions between CQI reports and HARQ-ACK it is necessary to report both on PUSCH instead of PUCCH. MPDCCH DCI format 6-0A shall be transmitted in downlink SF#4 and #9 to allow periodic CQI to multiplex with the HARQACK on PUSCH in uplink subframe SF#8 and #3.</p>					

Table 8.11.1.2.1.3-2: Minimum performance for PDSCH

Test Number	Reference Channel	OCNG Pattern			Propagation Conditions (Note1)			Correlation Matrix and Antenna Configuration (Note 2)	Reference Value		UE Category
		Cell 1	Cell 2	Cell 3	Cell 1	Cell 2	Cell 3		Fraction of Maximum Throughput (%)	SNR (dB) (Note 3)	
1	R.95 TDD	OP.1 TDD	N/A	N/A	EPA5	EPA5	EPA5	4x1 Low	70	11.1	M2
<p>Note 1: The propagation conditions for Cell 1, Cell 2 and Cell 3 are statistically independent.</p> <p>Note 2: The correlation matrix and antenna configuration apply for Cell 1, Cell 2 and Cell 3.</p> <p>Note 3: SNR corresponds to <math>\bar{E}_s/N_{oc}</math> of cell 1.</p>											

### 8.11.1.2.2 Closed-loop spatial multiplexing performance (User-Specific Reference Symbols)

#### 8.11.1.2.2.1 Single-layer Spatial Multiplexing

For single-layer transmission on antenna ports 7 or 8 upon detection of a PDCCH with DCI format 6-1A, the requirements are specified in Table 8.11.1.2.2.1-2 with the addition of the parameters in Table 8.11.1.2.2.1-1 and the downlink physical channel setup according to Annex C.3.2. The purpose of these tests is to verify rank-1 performance on one of the antenna ports 7 or 8.

Table 8.11.1.2.2.1-1: Test Parameters for Testing CDM-multiplexed DM RS (single layer)

Parameter	Unit	Test 1	Test 2	Test 3	
Downlink power allocation	$\rho_A$	dB	0	0	0
	$\rho_B$	dB	0 (Note 1)	0 (Note 1)	0 (Note 1)
	$\sigma$	dB	-3	-3	-3
	$\delta$	dB	0	0	0
Cell-specific reference signals		Antenna ports 0,1	Antenna ports 0,1	Antenna ports 0,1	
Beamforming model		Annex B.4.1	Annex B.4.1	Annex B.4.1	
$N_{oc}$ at antenna port	dBm/15kHz	-98	-98	-98	
Symbols for unused PRBs		OCNG (Note 3)	OCNG (Note 3)	OCNG (Note 3)	
Number of allocated resource blocks (Note 2)	PRB	6	6	6	
Simultaneous transmission		No	No	No	
PDSCH transmission mode		9	9	9	
Coverage enhancement mode		CE Mode A	CE Mode A	CE Mode A	
OFDM starting symbol (startSymbolBR)		2	2	2	
Maximum number of repetitions for PDSCH ( <i>pdscch-maxNumRepetitionCEmodeA</i> )		Not configured	Not configured	Not configured	
Frequency hopping ( <i>mpdcch-pdscch-HoppingConfig</i> )		Enabled	Enabled	Enabled	
PDSCH repetition number		8	4	2	
Frequency hopping offset ( <i>mpdcch-pdscch-HoppingOffset</i> )		1	1	1	
Frequency hopping interval (interval-TDD)	ms	10	1	1	
MPDCCH transmission duration ( <i>mPDCCH-NumRepetition</i> )	ms	8	2	1	
MPDCCH repetition number		8	2	1	
Number of narrowbands for frequency hopping ( <i>mpdcch-pdscch-HoppingNB</i> )		2	2	2	
Starting subframe configuration for MPDCCH ( <i>mpdcch_startSF_U ESS</i> )		10	20	20	
Narrowband for MPDCCH ( <i>mpdcch_Narrowband</i> )		7	7	7	
MPDCCH aggregation level		24	24	24	
<p>Note 1: <math>\rho_B = 1</math>.</p> <p>Note 2: The modulation symbols of the signal under test are mapped onto antenna port 7 or 8.</p> <p>Note 3: These physical resource blocks are assigned to an arbitrary number of virtual UEs with one PDSCH per virtual UE; the data transmitted over the OCNG PDSCHs shall be uncorrelated pseudo random data, which is QPSK modulated.</p> <p>Note 4: For each test, DC subcarrier puncturing shall be considered.</p> <p>Note 5: If not otherwise stated, the values in this table refer to parameters in TS 36.211 [4] or/and TS 36.213 [6] as appropriate.</p>					



**Table 8.11.1.2.2.1-2: Minimum performance for CDM-multiplexed DM RS without simultaneous transmission (FRC) with multiple CSI-RS configurations**

Test number	Bandwidth and MCS	Reference Channel	OCNG Pattern	Propagation Condition	Correlation Matrix and Antenna Configuration	Reference value		UE Category
						Fraction of Maximum Throughput (%)	SNR (dB)	
1	10MHz QPSK 1/3	R.80 TDD	OP.2 TDD	EPA5	2x1 Low	70	-2.5	M1
2	10MHz QPSK 1/3	R.80-1 TDD	OP.2 TDD	EPA5	2x2 Low	70	-3.6	≥1
3	10MHz QPSK 1/3	R.80-2 TDD	OP.2 TDD	EPA5	2x4 Low	70	-3.7	≥1

### 8.11.1.2.3 Transmit diversity performance (Cell-Specific Reference Symbols)

#### 8.11.1.2.3.1 Minimum Requirement 2 Tx Antenna Port supporting narrowband transmission

The requirements are specified in Table 8.11.1.2.3.1-2, with the addition of the parameters in Table 8.11.1.2.3.1-1 and Table 8.11.1.2.3.1-1a, and the downlink physical channel setup according to Annex C.3.2. The purpose is to verify the performance of transmit diversity (SFBC) with 2 transmitter antennas.

Table 8.11.1.2.3.1-1: Test Parameters for Transmit diversity performance (FRC)

Parameter	Unit	Test 1 (Note 3)	Test 2 (Note 3)	Test 2a (Note 3)	Test 3 (Note 3)	Test 4 (Note 3)
Downlink power allocation	$\rho_A$	dB	-3	-3	-3	-3
	$\rho_B$	dB	-3 (Note 1)	-3 (Note 1)	-3 (Note 1)	-3 (Note 1)
	$\sigma$	dB	0	0	0	0
	$\delta$	dB	3	3	3	3
$N_{oc}$ at antenna port	dBm/15kHz	-98	-98	-98	-98	-98
ACK/NACK feedback mode		Multiplexin g	Multiplexin g	Multiplexin g	Multiplexin g	Multiplexin g
PDSCH transmission mode		2	2	2	2	2
Coverage enhancement mode		CE Mode B	CE Mode A	CE Mode A	CE Mode B	CE Mode B
PDSCH transmission mode		2	2	2	2	2
OFDM starting symbol (startSymbolBR)		2	2	2	2	2
Maximum number of repetitions (for PDSCH ( <i>pdsch-maxNumRepetitionCEmodeA/pdsch-maxNumRepetitionCEmodeB</i> ))		Not configured	Not configured	Not configured	Not configured	Not configured
PDSCH repetition number		64	1	1	32	16
Frequency hopping (mpdcch-pdsch-HoppingConfig)		Enabled	Disabled	Disabled	Enabled	Enabled
Frequency hopping offset (mpdcch-pdsch-HoppingOffset)		1	N/A	N/A	1	1
Frequency hopping interval (interval-TDD)	ms	20	N/A	N/A	20	10
MPDCCH transmission duration (mPDCCH-NumRepetition)	ms	64	1	1	32	8
MPDCCH repetition number		64	1	1	32	8
Number of narrowbands for frequency hopping (mpdcch-pdsch-HoppingNB)		4	N/A	N/A	4	4
Starting subframe configuration for MPDCCH (mpdcch-startSF-U ESS)		8	1	1	8	10
Narrowband for MPDCCH (mpdcch_Narrowband)		7	0	0	7	7
MPDCCH aggregation level		24	8	8	24	24
CRS muting outside UE RF bandwidth (crs-IntfMitigEnabled)		Disabled	Disabled	Enabled	Disabled	Disabled
Number of PRBs for CRS transmission (crs-IntfMitigNumPRBs)		N/A	N/A	6	N/A	N/A
Note 1: $P_B = 1$ .						
Note 2: For each test, DC subcarrier puncturing shall be considered.						
Note 3: Test 1, test 3 and test 4 are applicable for UE supporting CE Mode B. Test 2 is applicable for UE not supporting CE Mode B. Test 2a is applicable for UE not supporting CE Mode B and UE capable of ce-CRS-IntfMitig.						
Note 4: If not otherwise stated, the values in this table refer to parameters in TS 36.211 [4] or/and TS 36.213 [6] as appropriate.						

Table 8.11.1.2.3.1-1a: Test Parameters for Transmit diversity performance (FRC)

Parameter	Unit	Test 5	Test 6
Downlink power allocation	$\rho_A$	dB	-3
	$\rho_B$	dB	-3 (Note 1)
	$\sigma$	dB	0
	$\delta$	dB	3
$N_{oc}$ at antenna port	dBm/15kHz	-98	-98
ACK/NACK feedback mode		Multiplexing	Multiplexing
PDSCH transmission mode		2	2
Coverage enhancement mode		CE Mode A	CE Mode A
PDSCH transmission mode		2	2
OFDM starting symbol (startSymbolBR)		2	2
Maximum number of repetitions (for PDSCH ( $pdsch-maxNumRepetitionCEmodeA/pdsch-maxNumRepetitionCEmodeB$ ))		Not configured	Not configured
PDSCH repetition number		1	1
Frequency hopping (mpdcch-pdsch-HoppingConfig)		Disabled	Disabled
Frequency hopping offset (mpdcch-pdsch-HoppingOffset)		N/A	N/A
Frequency hopping interval (interval-TDD)	ms	N/A	N/A
MPDCCH transmission duration (mPDCCH-NumRepetition)	ms	4	1
MPDCCH repetition number		4	1
Number of narrowbands for frequency hopping (mpdcch-pdsch-HoppingNB)		N/A	N/A
Starting subframe configuration for MPDCCH (mpdcch-startSF-UeSS)		1	1
Narrowband for MPDCCH (mpdcch_Narrowband)		0	0
MPDCCH aggregation level		8	8
CRS muting outside UE RF bandwidth (crs-IntfMitigEnabled)		Disabled	Disabled
Activation of 64QAM for non-repeated PDSCH in CE Mode A (ce-PDSCH-64QAM-Config)		Disabled	Enabled
Note 1: $P_B = 1$ .			
Note 2: For each test, DC subcarrier puncturing shall be considered.			
Note 3: If not otherwise stated, the values in this table refer to parameters in TS 36.211 [4] or/and TS 36.213 [6] as appropriate.			
Note 4: Test 6 is applicable for UE capable of ce-PDSCH-64QAM.			

Table 8.11.1.2.3.1-2: Minimum performance Transmit Diversity (FRC)

Test number	Bandwidth and MCS	Reference Channel	OCNG Pattern	Propagation Condition	Correlation Matrix and Antenna Configuration	Reference value		UE Category
						Fraction of Maximum Throughput (%)	SNR (dB)	
1	10MHz QPSK 1/10	R.81 TDD	OP.2 TDD	ETU1	2x1 Low	70	-14.0	M1
2	10MHz 16QAM 1/2	R.79 TDD	OP.2 TDD	EPA5	2x1 Low	70	9.6	M1
2a	10MHz 16QAM 1/2	R.79 TDD	OP.2 TDD	EPA5	2x1 Low	70	9.8	M1
3	10MHz QPSK 1/10	R.81-1 TDD	OP.2 TDD	ETU1	2x2 Low	70	-13.3	$\geq 1$
4	10MHz QPSK 1/10	R.81-2 TDD	OP.2 TDD	ETU1	2x4 Low	70	-13.3	$\geq 1$
5	10MHz QPSK 1/3	R.103 TDD	OP.2 TDD	EPA200	2x1 Low	70	3.5	M1
6	10MHz 64QAM 0.4	R.104 TDD	OP.2 TDD	EPA5	2x1 Low	70	13.5	M1

## 8.11.1.2.3.2 Minimum Requirement 2 Tx Antenna Port supporting wideband transmission

The requirements are specified in Table 8.11.1.2.3.2-2, with the addition of the parameters in Table 8.11.1.2.3.2-1 and the downlink physical channel setup according to Annex C.3.2. The purpose is to verify the performance of transmit diversity (SFBC) with 2 transmitter antennas.

Table 8.11.1.2.3.2-1: Test Parameters for Transmit diversity performance (FRC)

Parameter		Unit	Test 1	Test 2	Test 2a (Note 4)	Test 3	Test 4
Downlink power allocation	$\rho_A$	dB	-3	-3	-3	-3	-3
	$\rho_B$	dB	-3 (Note 1)	-3 (Note 1)	-3 (Note 1)	-3 (Note 1)	-3 (Note 1)
	$\sigma$	dB	0	0	0	0	0
	$\delta$	dB	3	3	3	3	3

$N_{oc}$ at antenna port	dBm/15kHz	-98	-98	-98	-98	-98
ACK/NACK feedback mode		Multiplexing	Multiplexing	Multiplexing	Multiplexing	Multiplexing
PDSCH transmission mode		2	2	2	2	2
Coverage enhancement mode		CE Mode A	CE Mode B	CE Mode B	CE Mode A	CE Mode A
OFDM starting symbol (startSymbolBR)		2	2	2	2	2
Maximum number of repetitions for PDSCH (pdsch-maxNumRepetitionCEmodeA/pdsch-maxNumRepetitionCEmodeB)		Not configured	Not configured	Not configured	Not configured	Not configured
PDSCH repetition number		8	32	32	4	2
Frequency hopping (mpdcch-pdsch-HoppingConfig)		Enabled	Enabled	Enabled	Disabled	Disabled
Frequency hopping offset (mpdcch-pdsch-HoppingOffset)		5	5	5	N/A	N/A
Frequency hopping interval (interval-TDD)	ms	5	20	20	N/A	N/A
Maximum number of repetitions (mpdcch-NumRepetition)		16	32	32	4	2
MPDCCH transmission duration	ms	16	32	32	4	2
Number of narrowbands for frequency hopping (mpdcch-pdsch-HoppingNB)		2	2	2	N/A	N/A
Starting subframe configuration for MPDCCH (mpdcch-startSF-UeSS)		5	8	8	8	10
Narrowband for MPDCCH (mpdcch_Narrowband)		0	0	0	0	0
MPDCCH aggregation level		24	24	24	24	24
CRS muting outside UE RF bandwidth (crs-IntfMitigEnabled)		Disabled	Disabled	Enabled	Disabled	Disabled
Number of PRBs for CRS transmission (crs-IntfMitigNumPRBs)		N/A	N/A	24	N/A	N/A
Note 1: $P_B = 1$ .						
Note 2: For each test, DC subcarrier puncturing shall be considered.						
Note 3: If not otherwise stated, the values in this table refer to parameters in TS 36.211 [4] or/and TS 36.213 [6] as appropriate.						
Note 4: Test 2a is applicable for UE supporting CE Mode B and UE capable of ce-CRS-IntfMitig.						

Table 8.11.1.2.3.2-2: Minimum performance Transmit Diversity (FRC)

Test number	Bandwidth and MCS	Reference Channel	OCNG Pattern	Propagation Condition	Correlation Matrix and Antenna Configuration	Reference value		UE Category
						Fraction of Maximum Throughput (%)	SNR (dB)	
1	10MHz QPSK 1/3	R.90 TDD	OP.2 TDD	EPA5	2x1 Low	70	-5.6	M2
2	10MHz QPSK 1/10	R.91 TDD	OP.2 TDD	ETU1	2x1 Low	70	-13.6	M2
2a	10MHz QPSK 1/10	R.91 TDD	OP.2 TDD	ETU1	2x1 Low	70	-13.4	M2
3	10MHz QPSK 1/2	R.92-1 TDD	OP.2 TDD	EPA5	2x2 Low	70	-4.9	≥1
4	10MHz QPSK 1/2	R.92-2 TDD	OP.2 TDD	EPA5	2x4 Low	70	-5.0	≥1

## 8.11.2 MPDCCH

The receiver characteristics of the MPDCCH are determined by the probability of miss-detection of the Downlink Scheduling Grant (Pm-dsg).

## 8.11.2.1 FDD and half-duplex FDD

Table 8.11.2.1-1: Test Parameters for MPDCCH (Category M1)

Parameter	Unit	CE Mode A (Test 1)	CE Mode B (Test 1)
OFDM starting symbol (startSymbolLC)	symbols	2	2
Unused RE-s and PRB-s		OCNG	OCNG
Cell ID		0	0
Downlink power allocation	$\rho_A$	dB	-3
	$\rho_B$	dB	-3
	$\sigma$	dB	0
	$\delta$	dB	3
$N_{oc}$ at antenna port	dBm/15 kHz	-98	-98
Cyclic prefix		Normal	Normal
Subframe Configuration		Non-MBSFN	Non-MBSFN
Precoder Update Granularity	PRB	1	1
	ms	4 (Note 2)	16 (Note 2)
Beamforming Pre-Coder		Annex B.4.4	Annex B.4.4
Cell Specific Reference Signal		Port 0 and 1	Port 0 and 1
Number of PRB per MPDCCH Set		4	2+4
Transmission type		Distributed	Localized
Frequency hopping		Disabled	Enabled
Number of frequency hopping narrowbands		N/A	4
Frequency hopping offset		N/A	1
Frequency hopping interval	ms	N/A	16
Value of G in MPDCCH start subframe ( <i>mpdcch-startSF-UESS</i> ) (Note 3)		1.5	1.5
Maximum number of repetitions ( <i>mPDCCH-NumRepetition</i> )		32	64
MPDCCH repetition number		32	64
MPDCCH narrowband ( <i>mpdcch-Narrowband</i> )		1	7
PDSCH TM		TM2	TM2
DCI Format		6-1A	6-1B
fdd-DownlinkOrTddSubframeBitmapBR		1111111111	1111111111
Note 1:	For each test, DC subcarrier puncturing shall be considered.		
Note 2:	Same precoding matrix is used for a PRB across subframes during the frequency hopping interval.		
Note 3:	For MPDCCH UE-specific search space the formula for the start subframe k0 is given in TS 36.213 [6] clause 9.1.5.		
Note 4:	If not otherwise stated, the values in this table refer to parameters in TS 36.211 [4] or/and TS 36.213 [6] as appropriate.		

Table 8.11.2.1-2: Test Parameters for MPDCCH (Category  $\geq 1$ )

Parameter	Unit	CE Mode A (Test 2)	CE Mode A (Test 3)	CE Mode B (Test 2)	CE Mode B (Test 3)
OFDM starting symbol (startSymbolLC)	symbols	2	2	2	2
Unused RE-s and PRB-s		OCNG	OCNG	OCNG	OCNG
Cell ID		0	0	0	0
Downlink power allocation	$\rho_A$	-3	0	0	0
	$\rho_B$	-3	0	0	0
	$\sigma$	0	-3	-3	-3
	$\delta$	3	0	0	0
$N_{oc}$ at antenna port	dBm/15kHz	-98	-98	-98	-98
Cyclic prefix		Normal	Normal	Normal	Normal
Subframe Configuration		Non-MBSFN	Non-MBSFN	Non-MBSFN	Non-MBSFN
Precoder Update Granularity	PRB	1	1	1	1
	ms	4 (Note 2)	4 (Note 2)	16 (Note 2)	16 (Note 2)
Beamforming Pre-Coder		Annex B.4.4	Annex B.4.4	Annex B.4.4	Annex B.4.4
Cell Specific Reference Signal		Port 0 and 1	Port 0 and 1	Port 0 and 1	Port 0 and 1
Number of PRB per MPDCCH Set		4	4	2+4	2+4
Transmission type		Distributed	Distributed	Localized	Localized
Frequency hopping		Disabled	Disabled	Enabled	Enabled
Number of frequency hopping narrowbands		N/A	N/A	4	4
Frequency hopping offset		N/A	N/A	1	1
Frequency hopping interval	ms	N/A	N/A	8	2
Value of G in MPDCCH start subframe ( <i>mpdcch-startSF-UESS</i> ) <sup>Note 3</sup>		1.5	1.5	1.5	1.5
Maximum number of repetitions ( <i>MPDCCH-NumRepetition</i> )		8	2	32	8
MPDCCH repetition number		8	2	32	8
MPDCCH narrowband ( <i>mpdcch-Narrowband</i> )		1	1	7	7
PDSCH TM		TM2	TM2	TM2	TM2
DCI Format		6-1A	6-1A	6-1B	6-1B
fdd-DownlinkOrTddSubframeBitmapBR		1111111111	1111111111	1111111111	1111111111
<p>Note 1: For each test, DC subcarrier puncturing shall be considered.</p> <p>Note 2: Same precoding matrix is used for a PRB across subframes during the frequency hopping interval.</p> <p>Note 3: For MPDCCH UE-specific search space the formula for the start subframe <math>k_0</math> is given in TS 36.213 [6] clause 9.1.5.</p> <p>Note 4: If not otherwise stated, the values in this table refer to parameters in TS 36.211 [4] or/and TS 36.213 [6] as appropriate.</p>					

## 8.11.2.1.1 CE Mode A

For the parameters specified in Table 8.11.2.1-1 and 8.11.2.1-2 the average probability of a missed downlink scheduling grant (Pm-dsg) shall be below the specified value in Table 8.11.2.1.1-1. The downlink physical setup is in accordance with Annex C.3.2.

**Table 8.11.2.1.1-1: Minimum performance CE Mode A MPDCCH**

Test number	Bandwidth	Aggregation level	Reference Channel	OCNG Pattern	Propagation Condition	Antenna configuration and correlation Matrix	Reference value		UE Category
							Pm-dsg (%)	SNR (dB)	
1	10 MHz	16 ECCE	R.82 FDD	OP.2 FDD	EPA5	2 x 1 Low	1	-4.8	M1
2	10 MHz	16 ECCE	R.82 FDD	OP.2 FDD	EPA5	2 x 2 Low	1	-6.5	≥1
3	10 MHz	16 ECCE	R.82 FDD	OP.2 FDD	EPA5	2 x 4 Low	1	-6.5	≥1

**8.11.2.1.2 CE Mode B**

For the parameters specified in Table 8.11.2.1-1 and 8.11.2.1-2 the average probability of a missed downlink scheduling grant (Pm-dsg) shall be below the specified value in Table 8.11.2.1.2-1. The downlink physical setup is in accordance with Annex C.3.2.

**Table 8.11.2.1.2-1: Minimum performance CE Mode B MPDCCH**

Test number	Bandwidth	Aggregation level	Reference Channel	OCNG Pattern	Propagation Condition	Antenna configuration and correlation Matrix	Reference value		UE Category
							Pm-dsg (%)	SNR (dB)	
1	10 MHz	24 ECCE	R.83 FDD	OP.2 FDD	ETU1	2 x 1 Low	1	-12	M1
2	10 MHz	24 ECCE	R.83 FDD	OP.2 FDD	ETU1	2 x 2 Low	1	-13.2	≥1
3	10 MHz	24 ECCE	R.83 FDD	OP.2 FDD	ETU1	2 x 4 Low	1	-12.8	≥1

**8.11.2.1.3 CE Mode A with TM9 interference model**

The requirements are specified in Table 8.11.2.1.3-2, with the addition of parameters in Table 8.11.2.1.3-1. In Table 8.11.2.1.3-2, Cell 1 is the serving cell, and Cell 2 and Cell 3 are the aggressor cells. The downlink physical channel setup is according to Annex C.3.2 for each of Cell 1, Cell 2 and Cell 3, respectively. The CRS assistance information [7] is provided to the UE and includes information on Cell 2 and Cell 3.

The purpose of the test is to verify the MPDCCH performance under assumption that UE applies CRS interference mitigation in the scenario with 2 CRS antenna ports in the serving and aggressor cells.



Table 8.11.2.1.3-1: Test Parameters for MPDCCH

Parameter		Unit	Cell 1	Cell 2	Cell 3
OFDM starting symbol (startSymbolLC)		symbols	2	2	2
Unused RE-s and PRB-s			OCNG	N/A	N/A
Cell ID			0	1	6
Downlink power allocation	$\rho_A$	dB	-3	-3	-3
	$\rho_B$	dB	-3	-3	-3
	$\sigma$	dB	0	0	0
	$\delta$	dB	3	3	3
Cell-specific reference signals			Antenna ports 0,1	Antenna ports 0,1	Antenna ports 0,1
$N_{oc}$ at antenna port		dBm/15kHz	-98		
$\hat{E}_c/N_{oc}$		dB	N/A	11.75	5.69
BWChannel		MHz	10	10	10
Cyclic Prefix			Normal	Normal	Normal
Subframe Configuration			Non-MBSFN	Non-MBSFN	Non-MBSFN
Precoder Update Granularity	PRB		1	N/A	N/A
	ms		4 (Note 2)	N/A	N/A
Beamforming Pre-Coder			Annex B. 4.4	N/A	N/A
Number of PRB per MPDCCH Set			4	N/A	N/A
Transmission type			Distributed	N/A	N/A
Frequency hopping			Disabled	N/A	N/A
Number of frequency hopping narrowbands			N/A	N/A	N/A
Frequency hopping offset			N/A	N/A	N/A
Frequency hopping interval		ms	4	N/A	N/A
Value of G in MPDCCH start subframe (mpdcch-startSF-UESS) (Note 3)			1.5	N/A	N/A
Maximum number of repetitions			1	N/A	N/A
MPDCCH narrowband (mpdcch-Narrowband)			1	N/A	N/A
PDSCH TM			TM2	N/A	N/A
DCI Format			6-1A	N/A	N/A
fdd-DownlinkOrTddSubframeBitmapBR			1111111111	N/A	N/A
Interference model			N/A	As specified in clause B.5.4	As specified in clause B.5.4
Probability of occurrence of transmission in interference cells		%	N/A	10	10
Probability of occurrence of PDSCH transmission rank in interfering cells	Rank 1	%	N/A	70	70
	Rank 2	%	N/A	30	30
Time offset relative to Cell 1		$\mu$ s	N/A	2	3
Frequency shift relative to Cell 1		Hz	N/A	200	300
Note 1: For each test, DC subcarrier puncturing shall be considered. Note 2: Same precoding matrix is used for a PRB across subframes during the frequency hopping interval Note 3: For MPDCCH UE-specific search space the formula for the start subframe $k_0$ is given in TS 36.213 [6] clause 9.1.5.					

Table 8.11.2.1.3-2: Minimum performance CE Mode A MPDCCH

Test Number	Aggregation level	Reference Channel	OCNG Pattern (Note 1)	Propagation Conditions (Note 2)			Antenna Configuration and Correlation Matrix (Note 3)	Reference Value	
				Cell 1	Cell 2	Cell 3		Pm-dsg (%)	SNR (dB) (Note 4)
1	16 ECCE	R.82 FDD	OP.2 FDD	EPA5	EPA5	EPA5	2x1 Low	1	15.4

Note 1: The OCNG pattern applies for Cell 1.  
 Note 2: The propagation conditions for Cell 1, Cell 2 and Cell 3 are statistically independent.  
 Note 3: The correlation matrix and antenna configuration apply for Cell 1, Cell 2 and Cell 3.  
 Note 4: SNR corresponds to  $E_s/N_{oc}$  of Cell 1.

#### 8.11.2.1.4 CE Mode A with CRS interference model

The requirements are specified in Table 8.11.2.1.4-2, with the addition of parameters in Table 8.11.2.1.4-1. In Table 8.11.2.1.4-2, Cell 1 is the serving cell, and Cell 2 and Cell 3 are the aggressor cells. The downlink physical channel setup is according to Annex C.3.2 for each of Cell 1, Cell 2 and Cell 3, respectively. The CRS assistance information [7] is provided to the UE and includes information on Cell 2 and Cell 3.

The purpose of the test is to verify the MPDCCH performance under assumption that UE applies CRS interference mitigation in the scenario with 2 CRS antenna ports in the serving and aggressor cells.

**Table 8.11.2.1.4-1: Test Parameters for MPDCCH**

Parameter		Unit	Cell 1	Cell 2	Cell 3
OFDM starting symbol (startSymbolLC)		symbols	2	2	2
Unused RE-s and PRB-s			OCNG	N/A	N/A
Cell ID			0	1	6
Downlink power allocation	$\rho_A$	dB	-3	-3	-3
	$\rho_B$	dB	-3	-3	-3
	$\sigma$	dB	0	0	0
	$\delta$	dB	3	3	3
Cell-specific reference signals			Antenna ports 0,1	Antenna ports 0,1	Antenna ports 0,1
$N_{oc}$ at antenna port		dBm/15kHz		-98	
$\bar{E}_s/N_{oc}$		dB	N/A	15.81	10.5
BW <sub>Channel</sub>		MHz	10	10	10
Cyclic Prefix			Normal	Normal	Normal
Subframe Configuration			Non-MBSFN	Non-MBSFN	Non-MBSFN
Precoder Update Granularity	PRB		1	N/A	N/A
	ms		4	N/A	N/A
Beamforming Pre-Coder			Annex B. 4.4	N/A	N/A
Number of PRB per MPDCCH Set			4	N/A	N/A
Transmission type			Distributed	N/A	N/A
Frequency hopping			Disabled	N/A	N/A
Number of frequency hopping narrowbands			N/A	N/A	N/A
Frequency hopping offset			N/A	N/A	N/A
Frequency hopping interval		ms	4	N/A	N/A
Value of G in MPDCCH start subframe ( <i>mpdcch-startSF-UESS</i> ) (Note 3)			1.5	N/A	N/A
Maximum number of repetitions			1	N/A	N/A
MPDCCH narrowband ( <i>mpdcch-Narrowband</i> )			1	N/A	N/A
PDSCH TM			TM2	N/A	N/A
DCI Format			6-1A	N/A	N/A
fdd-DownlinkOrTddSubframeBitmapBR			1111111111	N/A	N/A
Interference model			N/A	As specified in clause B.6.5	As specified in clause B.6.5
Time offset relative to Cell 1		$\mu$ s	N/A	2	3
Frequency shift relative to Cell 1		Hz	N/A	200	300
Note 1: For each test, DC subcarrier puncturing shall be considered.					
Note 2: Same precoding matrix is used for a PRB across subframes during the frequency hopping interval					
Note 3: For MPDCCH UE-specific search space the formula for the start subframe k0 is given in TS 36.213 [6] clause 9.1.5.					

Table 8.11.2.1.4-2: Minimum performance CE Mode A MPDCCH

Test Number	Aggregation level	Reference Channel	OCNG Pattern (Note 1)	Propagation Conditions (Note 2)			Antenna Configuration and Correlation Matrix (Note 3)	Reference Value	
				Cell 1	Cell 2	Cell 3		Pm-dsg (%)	SNR (dB) (Note 4)
1	4 ECCE	R.96 FDD	OP.2 FDD	EPA5	EPA5	EPA5	2x1 Low	1	15.8
Note 1: The OCNG pattern applies for Cell 1. Note 2: The propagation conditions for Cell 1, Cell 2 and Cell 3 are statistically independent. Note 3: The correlation matrix and antenna configuration apply for Cell 1, Cell 2 and Cell 3. Note 4: SNR corresponds to $E_s/N_{oc}$ of Cell 1.									

## 8.11.2.1.5 CE Mode A and CE Mode B when CRS-ChEstMPDCCH-Config is configured

For the parameters specified in Table 8.11.2.1.5-1 the average probability of a missed downlink scheduling grant (Pm-dsg) shall be below the specified value in Table 8.11.2.1.5-2 for CE Mode A and in Table 8.11.2.1.5-3 for CE Mode B. The downlink physical setup is in accordance with Annex C.3.2.

Table 8.11.2.1.5-1: Test Parameters for MPDCCH (Category M1)

Parameter	Unit	CE Mode A (Test 1)	CE Mode B (Test 1)
OFDM starting symbol (startSymbolLC)	symbols	2	2
Unused RE-s and PRB-s		OCNG	OCNG
Cell ID		0	0
Downlink power allocation	$\rho_A$	dB	0
	$\rho_B$	dB	-3
	$\sigma$	dB	0
	$\delta$	dB	3
$N_{oc}$ at antenna port	dBm/15 kHz	-98	-98
Cyclic prefix		Normal	Normal
Subframe Configuration		Non-MBSFN	Non-MBSFN
Precoder Update Granularity	PRB	N/A	Note 2
	ms	N/A	Note 2

Beamforming Pre-Coder		Note 2	Note 2
Cell Specific Reference Signal		Port 0 and 1	Port 0 and 1
Number of PRB per MPDCCH Set		4	2+4
Transmission type		Distributed	Localized
Frequency hopping		Disabled	Enabled
Number of frequency hopping narrowbands		N/A	4
Frequency hopping offset		N/A	1
Frequency hopping interval	ms	N/A	16
Value of G in MPDCCH start subframe ( <i>mpdcch-startSF-UESS</i> ) (Note 3)		1.5	1.5
Maximum number of repetitions ( <i>mPDCCH-NumRepetition</i> )		16	32
MPDCCH repetition number		16	32
MPDCCH narrowband ( <i>mpdcch-Narrowband</i> )		1	7
PDSCH TM		TM2	TM2
DCI Format		6-1A	6-1B
<i>fd-DownlinkOrTddSubframeBitmapBR</i>		1111111111	1111111111
<i>mpdcch-crs-config</i>		Configured	Configured
Power offset between CRS and DMRS antenna ports of MPDCCH	dB	0	0
<i>mpdcch-crs-localized-mapping-type</i>		N/A	Not configured
Note 1: For each test, DC subcarrier puncturing shall be considered.			
Note 2: TS 36.211 6.8B.5.			
Note 3: For MPDCCH UE-specific search space the formula for the start subframe $k_0$ is given in TS 36.213 [6] clause 9.1.5.			
Note 4: If not otherwise stated, the values in this table refer to parameters in TS 36.211 [4] or/and TS 36.213 [6] as appropriate.			

Table 8.11.2.1.5-2: Minimum performance CE Mode A MPDCCH

Test number	Bandwidth	Aggregation level	Reference Channel	OCNG Pattern	Propagation Condition	Antenna configuration and correlation Matrix	Reference value		UE Category
							Pm-dsg (%)	SNR (dB)	
1	10 MHz	16 ECCE	R.82 FDD	OP.2 FDD	EPA5	2 x 1 Low	1	-3.4	M1

Table 8.11.2.1.5-3: Minimum performance CE Mode B MPDCCH

Test number	Bandwidth	Aggregation level	Reference Channel	OCNG Pattern	Propagation Condition	Antenna configuration and correlation Matrix	Reference value		UE Category
							Pm-dsg (%)	SNR (dB)	
1	10 MHz	24 ECCE	R.83 FDD	OP.2 FDD	ETU1	2 x 1 Low	1	-9.5	M1

## 8.11.2.2.5 CE Mode A and CE Mode B when CRS-ChEstMPDCCH-Config is configured

For the parameters specified in Table 8.11.2.2.5-1 the average probability of a missed downlink scheduling grant (Pm-dsg) shall be below the specified value in Table 8.11.2.2.5-2 for CE Mode A and in Table 8.11.2.2.5-3 for CE Mode B. The downlink physical setup is in accordance with Annex C.3.2.

Table 8.11.2.2.5-1: Test Parameters for MPDCCH (Category M1)

Parameter	Unit	CE Mode A	CE Mode B
OFDM starting symbol (startSymbolLC)	symbols	2	2
Unused RE-s and PRB-s		OCNG	OCNG
Cell ID		0	0
Downlink power allocation	$\rho_A$	dB	-3
	$\rho_B$	dB	-3
	$\sigma$	dB	0
	$\delta$	dB	3
$N_{oc}$ at antenna port	dBm/15k Hz	-98	-98
Cyclic prefix		Normal	Normal
Subframe Configuration		Non-MBSFN	Non-MBSFN
Precoder Update Granularity	PRB	N/A	Not e2
	ms	N/A	Note 2
Beamforming Pre-Coder		Note 2	Note 2
Cell Specific Reference Signal		Port 0 and 1	Port 0 and 1
Number of PRB per MPDCCH Set		4	2+4
Transmission type		Distributed	Localized
Frequency hopping		Disabled	Enabled
Number of frequency hopping narrowbands		N/A	4
Frequency hopping offset		N/A	1
Frequency hopping interval	ms	N/A	20
Value of G in MPDCCH start subframe ( <i>mpdcch-startSF-UeSS</i> ) (Note 4)		5	5
Maximum number of repetitions ( <i>mPDCCH-NumRepetition</i> )		16	32
MPDCCH repetition number		16	32
MPDCCH narrowband ( <i>mpdcch-Narrowband</i> )		1	7
PDSCH TM		TM2	TM2
DCI Format		6-1A	6-1B
TDD UL/DL Configuration		0	0
TDD Special Subframe		1	1
fdd-DownlinkOrTddSubframeBitmapBR		1000010000	1000010000
mpdcch-crs-config		Configured	Configured
Power offset between CRS and DMRS antenna ports of MPDCCH	dB	0	0
mpdcch-crs-localized-mapping-type		N/A	Not configured
Note 1:	For each test, DC subcarrier puncturing shall be considered.		
Note 2:	TS 36.211 6.8B.5		
Note 3:	The special subframes are not supported by MPDCCH and are assumed as non- BL/CE DL subframes.		
Note 4:	For MPDCCH UE-specific search space the formula for the start subframe $k_0$ is given in TS 36.213 [6] clause 9.1.5.		
Note 5:	If not otherwise stated, the values in this table refer to parameters in TS 36.211 [4] or/and TS 36.213 [6] as appropriate.		

Table 8.11.2.2.5-2: Minimum performance CE Mode A MPDCCH

Test number	Bandwidth	Aggregation level	Reference Channel	OCNG Pattern	Propagation Condition	Antenna configuration and correlation Matrix	Reference value		UE Category
							Pm-dsg (%)	SNR (dB)	
1	10 MHz	16 ECCE	R.82 TDD	OP.2 TDD	EPA5	2 x 1 Low	1	-4.1	M1

Table 8.11.2.2.5-3: Minimum performance CE Mode B MPDCCH

Test number	Bandwidth	Aggregation level	Reference Channel	OCNG Pattern	Propagation Condition	Antenna configuration and correlation Matrix	Reference value		UE Category
							Pm-dsg (%)	SNR (dB)	
1	10 MHz	24 ECCE	R.83 TDD	OP.2 TDD	ETU1	2 x 1 Low	1	-9.7	M1

## 8.11.2.2 TDD

Table 8.11.2.2-1: Test Parameters for MPDCCH (Category M1)

Parameter	Unit	CE Mode A	CE Mode B
OFDM starting symbol (startSymbolLC)	symbols	2	2
Unused RE-s and PRB-s		OCNG	OCNG
Cell ID		0	0
Downlink power allocation	$\rho_A$	dB	-3
	$\rho_B$	dB	-3
	$\sigma$	dB	0
	$\delta$	dB	3
$N_{oc}$ at antenna port	dBm/15 kHz	-98	-98
Cyclic prefix		Normal	Normal
Subframe Configuration		Non-MBSFN	Non-MBSFN
Precoder Update Granularity	PRB	1	1
	ms	5 (Note 2)	20 (Note 2)
Beamforming Pre-Coder		Annex B.4.4	Annex B.4.4
Cell Specific Reference Signal		Port 0 and 1	Port 0 and 1
Number of PRB per MPDCCH Set		4	2+4
Transmission type		Distributed	Localized
Frequency hopping		Diabed	Enabled
Number of frequency hopping narrowbands		N/A	4
Frequency hopping offset		N/A	1
Frequency hopping interval	ms	N/A	20
Value of G in MPDCCH start subframe ( <i>mpdcch-startSF-U ESS</i> ) (Note 4)		5	5
Maximum number of repetitions ( <i>MPDCCH-NumRepetition</i> )		16	32
MPDCCH repetition number		16	32
MPDCCH narrowband ( <i>mpdcch-Narrowband</i> )		1	7
PDSCH TM		TM2	TM2
DCI Format		6-1A	6-1B
TDD UL/DL Configuration		0	0
TDD Special Subframe		1	1
fdd-DownlinkOrTddSubframeBitmapBR		1000010000	1000010000
Note 1:	For each test, DC subcarrier puncturing shall be considered.		
Note 2:	Same precoding matrix is used for a PRB across subframes during the frequency hopping interval.		
Note 3:	The special subframes are not supported by MPDCCH, and are assumed as non- BL/CE DL subframes.		
Note 4:	For MPDCCH UE-specific search space the formula for the start subframe $k_0$ is given in TS 36.213 [6] clause 9.1.5.		
Note 5:	If not otherwise stated, the values in this table refer to parameters in TS 36.211 [4] or/and TS 36.213 [6] as appropriate.		

Table 8.11.2.2-2: Test Parameters for MPDCCH (Category  $\geq 1$ )

Parameter	Unit	CE Mode A (Test 2)	CE Mode A (Test 3)	CE Mode B (Test 2)	CE Mode B (Test 3)
OFDM starting symbol (startSymbolLC)	symbols	2	2	2	2
Unused RE-s and PRB-s		OCNG	OCNG	OCNG	OCNG
Cell ID		0	0	0	0
Downlink power allocation	$\rho_A$	-3	-3	0	0
	$\rho_B$	-3	-3	0	0
	$\sigma$	0	0	-3	-3
	$\delta$	3	3	0	0
$N_{oc}$ at antenna port	dBm/15kHz	-98	-98	-98	-98
Cyclic prefix		Normal	Normal	Normal	Normal
Subframe Configuration		Non-MBSFN	Non-MBSFN	Non-MBSFN	Non-MBSFN
Precoder Update Granularity	PRB	1	1	1	1
	ms	5 (Note 2)	5 (Note 2)	20 (Note 2)	20 (Note 2)
Beamforming Pre-Coder		Annex B.4.4	Annex B.4.4	Annex B.4.4	Annex B.4.4
Cell Specific Reference Signal		Port 0 and 1	Port 0 and 1	Port 0 and 1	Port 0 and 1
Number of PRB per MPDCCH Set		4	4	2+4	2+4
Transmission type		Distributed	Distributed	Localized	Localized
Frequency hopping		Disabled	Disabled	Enabled	Enabled
Number of frequency hopping narrowbands		N/A	N/A	4	4
Frequency hopping offset		N/A	N/A	1	1
Frequency hopping interval	ms	N/A	N/A	5	5
Value of G in MPDCCH start subframe ( <i>mpdcch-startSF-U ESS</i> ) <small>Note 3</small>		5	5	5	5
Maximum number of repetitions ( <i>MPDCCH-NumRepetition</i> )		4	2	16	8
MPDCCH repetition number		4	2	16	8
MPDCCH narrowband ( <i>mpdcch-Narrowband</i> )		1	1	7	7
PDSCH TM		TM2	TM2	TM2	TM2
DCI Format		6-1A	6-1A	6-1B	6-1B
fdd-DownlinkOrTddSubframeBitmapBR		1000010000	1000010000	1000010000	1000010000
<p>Note 1: For each test, DC subcarrier puncturing shall be considered.</p> <p>Note 2: Same precoding matrix is used for a PRB across subframes during the frequency hopping interval.</p> <p>Note 3: For MPDCCH UE-specific search space the formula for the start subframe <math>k_0</math> is given in TS 36.213 [6] clause 9.1.5.</p> <p>Note 4: If not otherwise stated, the values in this table refer to parameters in TS 36.211 [4] or/and TS 36.213 [6] as appropriate.</p>					

## 8.11.2.2.1 CE Mode A

For the parameters specified in Table 8.11.2.2-1 and 8.11.2.2-2 the average probability of a missed downlink scheduling grant (Pm-dsg) shall be below the specified value in Table 8.11.2.2.1-1. The downlink physical setup is in accordance with Annex C.3.2.

Table 8.11.2.2.1-1: Minimum performance CE Mode A MPDCCH

Test number	Bandwidth	Aggregation level	Reference Channel	OCNG Pattern	Propagation Condition	Antenna configuration and correlation Matrix	Reference value		UE Category
							Pm-dsg (%)	SNR (dB)	
1	10 MHz	16 ECCE	R.82 TDD	OP.2 TDD	EPA5	2 x 1 Low	1	-5.3	M1
2	10 MHz	16 ECCE	R.82 TDD	OP.2 TDD	EPA5	2 x 2 Low	1	-5.3	≥1
3	10 MHz	16 ECCE	R.82 TDD	OP.2 TDD	EPA5	2 x 4 Low	1	-6.8	≥1

## 8.11.2.2.2 CE Mode B

For the parameters specified in Table 8.11.2.2-1 and 8.11.2.2-2 the average probability of a missed downlink scheduling grant (Pm-dsg) shall be below the specified value in Table 8.11.2.2.2-1. The downlink physical setup is in accordance with Annex C.3.2.

Table 8.11.2.2.2-1: Minimum performance CE Mode B MPDCCH

Test number	Bandwidth	Aggregation level	Reference Channel	OCNG Pattern	Propagation Condition	Antenna configuration and correlation Matrix	Reference value		UE Category
							Pm-dsg (%)	SNR (dB)	
1	10 MHz	24 ECCE	R.83 TDD	OP.2 TDD	ETU1	2 x 1 Low	1	-10.1	M1
2	10 MHz	24 ECCE	R.83 TDD	OP.2 TDD	ETU1	2 x 2 Low	1	-12.3	≥1
3	10 MHz	24 ECCE	R.83 TDD	OP.2 TDD	ETU1	2 x 4 Low	1	-12.8	≥1

## 8.11.2.2.3 CE Mode A with TM9 interference model

The requirements are specified in Table 8.11.2.2.3-2, with the addition of parameters in Table 8.11.2.2.3-1. In Table 8.11.2.2.3-2, Cell 1 is the serving cell, and Cell 2 and Cell 3 are the aggressor cells. The downlink physical channel setup is according to Annex C.3.2 for each of Cell 1, Cell 2 and Cell 3, respectively. The CRS assistance information [7] is provided to the UE and includes information on Cell 2 and Cell 3.

The purpose of the test is to verify the MPDCCH performance under assumption that UE applies CRS interference mitigation in the scenario with 2 CRS antenna ports in the serving and aggressor cells.

Table 8.11.2.2.3-1: Test Parameters for MPDCCH (TM9 interference model)

Parameter	Unit	Cell 1	Cell 2	Cell 3
OFDM starting symbol (startSymbolLC)	symbols	2	2	2
Unused RE-s and PRB-s		OCNG	N/A	N/A
Cell ID		0	1	6
Downlink power allocation	$\rho_A$	dB	-3	-3
	$\rho_B$	dB	-3	-3
	$\sigma$	dB	0	0
	$\delta$	dB	3	3
Cell-specific reference signals		Antenna ports 0,1	Antenna ports 0,1	Antenna ports 0,1
$N_{oc}$ at antenna port	dBm/15kHz		-98	
$\bar{E}_s/N_{oc}$	dB	N/A	11.75	5.69
$BW_{Channel}$	MHz	10	10	10



Cyclic Prefix			Normal	Normal	Normal
Subframe Configuration			Non-MBSFN	Non-MBSFN	Non-MBSFN
Precoder Update Granularity		PRB	1	N/A	N/A
		ms	4 (Note 2)	N/A	N/A
Beamforming Pre-Coder			Annex B. 4.4	N/A	N/A
Number of PRB per MPDCCH Set			4	N/A	N/A
Transmission type			Distributed	N/A	N/A
Frequency hopping			Disabled	N/A	N/A
Number of frequency hopping narrowbands			N/A	N/A	N/A
Frequency hopping offset			N/A	N/A	N/A
Frequency hopping interval		ms	4	N/A	N/A
Value of G in MPDCCH start subframe ( <i>mpdcch-startSF-UESS</i> ) (Note 3)			1.5	N/A	N/A
Maximum number of repetitions			1	N/A	N/A
MPDCCH narrowband ( <i>mpdcch-Narrowband</i> )			1	N/A	N/A
PDSCH TM			TM2	N/A	N/A
DCI Format			6-1A	N/A	N/A
fdd-DownlinkOrTddSubframeBitmapBR			1000010000	N/A	N/A
Interference model			N/A	As specified in clause B.5.4	As specified in clause B.5.4
Probability of occurrence of transmission in interference cells		%	N/A	10	10
Probability of occurrence of PDSCH transmission rank in interfering cells		Rank 1	%	N/A	70
		Rank 2	%	N/A	30
Time offset relative to Cell 1		μs	N/A	2	3
Frequency shift relative to Cell 1		Hz	N/A	200	300
Note 1: For each test, DC subcarrier puncturing shall be considered.					
Note 2: Same precoding matrix is used for a PRB across subframes during the frequency hopping interval					
Note 3: For MPDCCH UE-specific search space the formula for the start subframe $k_0$ is given in TS 36.213 [6] clause 9.1.5.					

Table 8.11.2.2.3-2: Minimum performance CE Mode A MPDCCH

Test Number	Aggregation level	Reference Channel	OCNG Pattern (Note 1)	Propagation Conditions (Note 2)			Antenna Configuration and Correlation Matrix (Note 3)	Reference Value	
				Cell 1	Cell 2	Cell 3		Pm-dsg (%)	SNR (dB) (Note 4)
1	16 ECCE	R.82 TDD	OP.2 TDD	EPA5	EPA5	EPA5	2x1 Low	1	15.5
Note 1: The OCNG pattern applies for Cell 1.									
Note 2: The propagation conditions for Cell 1, Cell 2 and Cell 3 are statistically independent.									
Note 3: The correlation matrix and antenna configuration apply for Cell 1, Cell 2 and Cell 3.									
Note 4: SNR corresponds to $E_s/N_{oc}$ of Cell 1.									

## 8.11.2.2.4 CE Mode A with CRS interference model

The requirements are specified in Table 8.11.2.2.4-2, with the addition of parameters in Table 8.11.2.2.4-1. In Table 8.11.2.2.4-2, Cell 1 is the serving cell, and Cell 2 and Cell 3 are the aggressor cells. The downlink physical channel setup is according to Annex C.3.2 for each of Cell 1, Cell 2 and Cell 3, respectively. The CRS assistance information [7] is provided to the UE and includes information on Cell 2 and Cell 3.

The purpose of the test is to verify the MPDCCH performance under assumption that UE applies CRS interference mitigation in the scenario with 2 CRS antenna ports in the serving and aggressor cells.

Table 8.11.2.2.4-1: Test Parameters for MPDCCH (CRS interference model)

Parameter	Unit	Cell 1	Cell 2	Cell 3
OFDM starting symbol (startSymbolLC)	symbols	2	2	2
Unused RE-s and PRB-s		OCNG	N/A	N/A

Cell ID			0	1	6
Downlink power allocation	$\rho_A$	dB	-3	-3	-3
	$\rho_B$	dB	-3	-3	-3
	$\sigma$	dB	0	0	0
	$\delta$	dB	3	3	3
Cell-specific reference signals			Antenna ports 0,1	Antenna ports 0,1	Antenna ports 0,1
$N_{oc}$ at antenna port	dBm/15kHz		-98		
$\bar{E}_s/N_{oc}$	dB		N/A	15.81	10.5
$BW_{channel}$	MHz		10	10	10
Cyclic Prefix			Normal	Normal	Normal
Subframe Configuration			Non-MBSFN	Non-MBSFN	Non-MBSFN
Precoder Update Granularity	PRB		1	N/A	N/A
	ms		4	N/A	N/A
Beamforming Pre-Coder			Annex B. 4.4	N/A	N/A
Number of PRB per MPDCCH Set			4	N/A	N/A
Transmission type			Distributed	N/A	N/A
Frequency hopping			Disabled	N/A	N/A
Number of frequency hopping narrowbands			N/A	N/A	N/A
Frequency hopping offset			N/A	N/A	N/A
Frequency hopping interval	ms		4	N/A	N/A
Value of G in MPDCCH start subframe ( <i>mpdcch-startSF-UESS</i> ) (Note 3)			1.5	N/A	N/A
Maximum number of repetitions			1	N/A	N/A
MPDCCH narrowband ( <i>mpdcch-Narrowband</i> )			1	N/A	N/A
PDSCH TM			TM2	N/A	N/A
DCI Format			6-1A	N/A	N/A
fdd-DownlinkOrTddSubframeBitmapBR			1000010000	N/A	N/A
Interference model			N/A	As specified in clause B.6.5	As specified in clause B.6.5
Time offset relative to Cell 1	$\mu$ s		N/A	2	3
Frequency shift relative to Cell 1	Hz		N/A	200	300
Note 1: For each test, DC subcarrier puncturing shall be considered. Note 2: Same precoding matrix is used for a PRB across subframes during the frequency hopping interval Note 3: For MPDCCH UE-specific search space the formula for the start subframe $k_0$ is given in TS 36.213 [6] clause 9.1.5.					

Table 8.11.2.2.4-2: Minimum performance CE Mode A MPDCCH

Test Number	Aggregation level	Reference Channel	OCNG Pattern (Note 1)	Propagation Conditions (Note 2)			Antenna Configuration and Correlation Matrix (Note 3)	Reference Value	
				Cell 1	Cell 2	Cell 3		Pm-dsg (%)	SNR (dB) (Note 4)
1	4 ECCE	R.96 TDD	OP.2 FDD	EPA5	EPA5	EPA5	2x1 Low	1	16.2
Note 1: The OCNG pattern applies for Cell 1, Cell 2 and Cell 3. Note 2: The propagation conditions for Cell 1, Cell 2 and Cell 3 are statistically independent. Note 3: The correlation matrix and antenna configuration apply for Cell 1, Cell 2 and Cell 3. Note 4: SNR corresponds to $\bar{E}_s/N_{oc}$ of Cell 1.									

### 8.11.3 PBCH

The receiver characteristics of the PBCH are determined by the probability of miss-detection of the PBCH for single decoding interval ( $P_{m-bch-s}$ ) and the probability of miss-detection of the PBCH for multiple decoding intervals ( $P_{m-bch-m}$ ), which are defined as

$$P_{m-bch-s} = 1 - \frac{A_s}{B_s}$$

$$P_{m-bch-m} = 1 - \frac{A_m}{B_m}$$

The probability of miss-detection of the PBCH for single decoding interval (Pm-bch-s) is calculated under assumption of single PBCH TTI interval decoding.  $A_s$  is the number of correctly decoded MIB PDUs and  $B_s$  is the number of transmitted MIB PDUs (redundancy versions for the same MIB are not counted separately).

The probability of miss-detection of the PBCH for multiple decoding intervals (Pm-bch-m) is calculated over multiple PBCH TTI intervals under assumption of independent PBCH decoding over these intervals.  $A_m$  is the number of PBCH decoding intervals with at least one correctly decoded MIB PDU and  $B_m$  is the total number of PBCH decoding intervals. A multiple PBCH decoding interval has 1120 ms duration consisting of continuous PBCH TTIs during the test.

### 8.11.3.1 FDD and half-duplex FDD

**Table 8.11.3.1-1: Test Parameters for PBCH**

Parameter		Unit	Transmit diversity
Downlink power allocation	PBCH_RA	dB	-3
	PBCH_RB	dB	-3
$N_{oc}$ at antenna port		dBm/15kHz	-98
Cyclic prefix			Normal
Cell ID			0
Repetition of the physical broadcast channel (Note 1)			Enabled
Cyclic prefix			Normal
Note 1: as specified in Table 6.6.4-1 in TS 36.211 [4].			

#### 8.11.3.1.1 Transmit diversity performance

For the parameters specified in Table 8.11.3.1-1 and Table 8.11.3.1.1-1, the averaged probability of a miss-detected PBCH (Pm-bchs and Pm-bchm) shall be below the specified value in Table 8.11.3.1.1-1. The downlink physical setup is in accordance with Annex C.3.2.

**Table 8.11.3.1.1-1: Minimum performance PBCH**

Test number	Bandwidth	Reference Channel	Propagation Condition	Antenna configuration and correlation Matrix	Reference value for single PBCH TTI		Reference value for multiple PBCH TTI	
					Pm-bchs (%)	SNR (dB)	Pm-bchm (%)	SNR (dB)
1	10 MHz	R.22	EPA1	2 x 1 Low	1	-1.9	1	-12.6

## 8.11.3.2 TDD

Table 8.11.3.2-1: Test Parameters for PBCH

Parameter	Unit	Transmit diversity
Uplink downlink configuration (Note 1)		1
Special subframe configuration (Note 2)		4
Downlink power allocation	PBCH_RA	-3
	PBCH_RB	-3
$N_{oc}$ at antenna port	dBm/15kHz	-98
Cyclic prefix		Normal
Cell ID		0
Repetition of the physical broadcast channel (Note 3)		Enabled
Cyclic prefix		Normal
Note 1: as specified in Table 4.2-2 in TS 36.211 [4].		
Note 2: as specified in Table 4.2-1 in TS 36.211 [4].		
Note 3: as specified in Table 6.6.4-2 in TS 36.211 [4].		

## 8.11.3.2.1 Transmit diversity performance

For the parameters specified in Table 8.11.3.2-1 and Table 8.11.3.2.1-1, the averaged probability of a miss-detected PBCH (Pm-bchs and Pm-bch-m) shall be below the specified value in Table 8.11.3.2.1-1. The downlink physical setup is in accordance with Annex C.3.2.

Table 8.11.3.2.1-1: Minimum performance PBCH

Test number	Bandwidth	Reference Channel	Propagation Condition	Antenna configuration and correlation Matrix	Reference value for single PBCH TTI		Reference value for multiple PBCH TTI	
					Pm-bchs (%)	SNR (dB)	Pm-bch-m (%)	SNR (dB)
1	10 MHz	R.22	EPA1	2 x 1 Low	1	-2.8	1	-12.9

## 8.12 Demodulation of Narrowband IoT

## 8.12.1 NPDSCH

8.12.1.1 Half-duplex FDD The parameters specified in Table 8.12.1.1-1 are valid for all half-duplex FDD tests unless otherwise stated.

**Table 8.12.1.1-1: Common Test Parameters**

Parameter	Unit	Value
Number of HARQ processes per component carrier (Note 2)	Processes	1 or 2
Maximum number of HARQ transmission		4
Cyclic Prefix		Normal
extraControlRegionSize-r13		3 for In-band and N/A for Standalone/Guard-band unless otherwise stated
downlinkBitmap-r13 and dl-Gap-r13		Not configured
dl-GapNonAnchor-r13 and downlinkBitmapNonAnchor-r13		Not configured
Unused REs or RB (Note 1)		OCNG
OCNG pattern		NB.OP.1
Note 1: For in-band mode, the REs for transmission of LTE signals including PDCCH, CRS should be filled by OCNG.		
Note 2: 1 is applicable for both UE Category NB1 and NB2; 2 is only applicable for UE Category NB2 if UE supports it.		

**Table 8.12.1.1-2: Test Parameters of related NPDCCH and NPUSCH format 2 configurations**

Parameter	Unit	Value
DCI format		DCI format N1
scheduling delay field ( $I_{\text{Delay}}$ )		For tests in 8.12.1.1.4: 1 For others: 1 for the first HARQ process; 2 for the second HARQ process if configured
$N_{\text{Rep}}^{\text{AV}}$ (ack-NACK-NumRepetitions-r13)		1
ACK/NACK resource field		0
Reference channel for NPDCCH		R.NB.3 FDD for one NRS antenna port; R.NB.4 FDD for two NRS antenna ports
$\alpha_{\text{offset}}$ (npdcch-Offset-USS-r13)		0

#### 8.12.1.1.1 Minimum Requirements for In-band

The requirements are specified in Table 8.12.1.1.1-2, with the addition of the parameters in Table 8.12.1.1.1 -1 and the downlink physical channel setup according to Annex C.3.2 and C.3.6. The purpose of these tests is to verify the performance.

Table 8.12.1.1.1-1: Test Parameters for NPDSCH under In-band

Parameter	Unit	Test 1, 2	
Downlink power allocation of LTE signal	$\rho_A$	dB	-3
	$\rho_B$	dB	-3(Note 1)
	$\sigma$	dB	0
$N_{oc}$ at antenna port	$N_{oc1}$	dBm/15kHz	-93 (Note 2)
	$N_{oc2}$	dBm/15kHz	-99 (Note 3)
LTE CRS port number (eutra-NumCRS-Ports-r13)		4	
NPDCCH repetition number	subframe	8 for Test 1; 16 for Test 2; 128 for Test 3.	
$R_{\max}$ ( $n_{pdccch-NumRepetitions-r13}$ )	subframe	8 for Test 1; 16 for Test 2; 128 for Test 3.	
$G$ ( $n_{pdccch-startSF-USS-r13}$ )		4 for Test 1; 2 for Test 2; 1.5 for Test 3	
Note 1: $P_B = 1$ . Note 2: This noise is applied to all subframes from the end of the NPDCCH to the end of the following NPDSCH transmission; Note 3: This noise is applied to all subframes from the end of the NPDSCH to the end of the following NPDCCH transmission.			

Table 8.12.1.1.1-2: Minimum performance under In-band with 2 NRS ports

Test number	Bandwidth	Carrier Type	Reference Channel	Repetition number	Propagation Condition	Correlation Matrix and Antenna Configuration	Reference value		UE Category
							Fraction of Maximum Throughput (%)	SNR (dB)	
1	200kHz	Anchor	R.NB.5 FDD	1	EPA5	2x1 Low	70%	6.9	NB1, NB2
2	200kHz	Anchor	R.NB.5 FDD	32	EPA5	2x1 Low	70%	-4.8	NB1, NB2
3	200kHz	Non-anchor	R.NB.5-1 FDD	256	ETU1	2x1 Low	70%	-9.8	NB1, NB2

#### 8.12.1.1.2 Minimum Requirements for Standalone/Guard-band

The requirements are specified in Table 8.12.1.1.2-2, with the addition of the parameters in Table 8.12.1.1.2 -1 and the downlink physical channel setup according to Annex C.3.6. The purpose of these tests is to verify the performance.

Table 8.12.1.1.2-1: Test Parameters for NPDSCH under Standalone/Guard-band

Parameter	Unit		Test 1, 2
$N_{oc}$ at antenna port	$N_{oc1}$	dBm/15kHz	-93 (Note 1)
	$N_{oc2}$	dBm/15kHz	-99 (Note 2)
NPDCCH repetition number	subframe		32 for Test 1; 256 for Test 2.
$R_{\text{max}}$ ( <i>npdcch-NumRepetitions-r13</i> )	subframe		64 for Test 1; 512 for Test 2.
$G$ ( <i>nPDCCH-startSF-USS-r13</i> )			1.5
Note 1:	This noise is applied to all subframes from the end of the NPDCCH to the end of the following NPDSCH transmission;		
Note 2:	This noise is applied to all subframes from the end of the NPDSCH to the end of the following NPDCCH transmission.		

Table 8.12.1.1.2-2: Minimum performance for NPDSCH under Standalone/Guard-band with 1 NRS port

Test number	Bandwidth	Carrier Type	Reference Channel	Repetition number	Propagation condition	Number of NRS ports	Antenna Configuration	Reference value		UE Category
								Fraction of Maximum Throughput (%)	SNR (dB)	
1	200kHz	Anchor	R.NB.6 FDD	32	EPA5	1	1x1	70%	-3.4	NB1, NB2
2	200kHz	Non-anchor	R.NB.6-1 FDD	256	ETU1	1	1x1	70%	10.2	NB1, NB2

## 8.12.1.1.3 Minimum Requirements for Standalone for UE Category NB2

The requirements are specified in Table 8.12.1.1.3-2, with the addition of the parameters in Table 8.12.1.1.3-1 and the downlink physical channel setup according to Annex C.3.6. The purpose of these tests is to verify the NPDSCH performance.

Table 8.12.1.1.3-1: Test Parameters for NPDSCH under Standalone

Parameter	Unit		Test 1
$N_{oc}$ at antenna port	$N_{oc1}$	dBm/15kHz	-93 (Note 1)
	$N_{oc2}$	dBm/15kHz	-96 (Note 2)
NPDCCH repetition number	subframe		4 for Test 1
$R_{\text{max}}$ ( <i>npdcch-NumRepetitions-r13</i> )	subframe		8 for Test 1
$G$ ( <i>nPDCCH-startSF-USS-r13</i> )			1.5
Note 1:	This noise is applied to all subframes from the end of the NPDCCH to the end of the following NPDSCH transmission;		
Note 2:	This noise is applied to all subframes from the end of the NPDSCH to the end of the following NPDCCH transmission.		

Table 8.12.1.1.3-2: Minimum performance for NPDSCH under Standalone with 1 NRS port

Test number	Bandwidth	Carrier Type	Reference Channel	Repetition number	Propagation condition	Number of NRS ports	Antenna Configuration	Reference value		UE Category
								Fraction of Maximum Throughput (%)	SNR (dB)	
1	200kHz	Non-anchor	R.NB.7 FDD	1	EPA5	1	1x1	70%	9.4	NB2

## 8.12.1.1.4 Minimum Requirements for Standalone for UE with multiple TBs interleaved transmission

The requirements are specified in Table 8.12.1.1.4-2, with the addition of the parameters in Table 8.12.1.1.4-1 and the downlink physical channel setup according to Annex C.3.6. The purpose of these tests is to verify NPDSCH performance when multiple TBs with interleaved transmission are scheduled by one DCI as specified in TS 36.213[6].

These requirements are applicable for UE of UE-Category-NB NB2 supporting multiple TBs scheduling with interleaved transmission when multiple TBs are scheduled.

Table 8.12.1.1.4-1: Test Parameters for NPDSCH under Standalone

Parameter	Unit	Test 1
$N_{oc}$ at antenna port	$N_{oc1}$	dBm/15kHz -93 (Note 1)
	$N_{oc2}$	dBm/15kHz -99 (Note 2)
NPDCCH repetition number	subframe	128 for Test 1
$R_{\max}$ ( $npdcch\text{-}NumRepetitions\text{-}r13$ )	subframe	128 for Test 1
$G$ ( $nPDCCCH\text{-}startSF\text{-}USS\text{-}r13$ )		1.5
Two HARQ processes ( $twoHARQ\text{-}ProcessesConfig\text{-}r14$ )		true
Multiple TBs scheduling ( $multiTB\text{-}Config\text{-}r16$ )		interleaved
Note 1:	This noise is applied to all subframes from the end of the NPDCCH to the end of the following NPDSCH transmission;	
Note 2:	This noise is applied to all subframes from the end of the NPDSCH to the end of the following NPDCCH transmission.	

Table 8.12.1.1.4-2: Minimum performance for NPDSCH under Standalone with 1 NRS port

Test number	Bandwidth	Carrier Type	Reference Channel	Repetition number	Propagation condition	Number of NRS ports	Antenna Configuration	Reference value		UE Category
								Fraction of Maximum Throughput (%)	SNR (dB)	
1	200kHz	Non-anchor	R.NB.8 FDD	1	ETU1	1	1x1	70%	-6.0	NB2



## 8.12.1.2 TDD

Table 8.12.1.2-1: Common Test Parameters

Parameter	Unit	Value
Uplink downlink configuration (Note 1)		4
Special subframe configuration (Note 2)		4
Number of HARQ processes per component carrier (Note 4)	Processes	1 or 2
Maximum number of HARQ transmission		4
Cyclic Prefix		Normal
extraControlRegionSize-r13		2 for In-band, N/A for Standalone/Guard-band unless otherwise stated
downlinkBitmap-r13 and dl-Gap-r13		Not configured
dl-GapNonAnchor-r13 and downlinkBitmapNonAnchor-r13		Not configured
Unused REs or RB (Note 3)		OCNG
OCNG pattern		NB.OP.1
Note 1: As specified in Table 4.2-2 in TS 36.211 [4]		
Note 2: As specified in Table 4.2-1 in TS 36.211 [4]		
Note 3: For in-band mode, the REs for transmission of LTE signals including PDCCH, CRS should be filled by OCNG.		
Note 4: 1 is applicable for both UE Category NB1 and NB2; 2 is only applicable for UE Category NB2 if UE supports it.		

Table 8.12.1.2-2: Test Parameters of related NPDCCH and NPUSCH format 2 configurations

Parameter	Unit	Value
DCI format		DCI format N1
scheduling delay field ( $I_{\text{Delay}}$ )		1 for the first HARQ process; 2 for the second HARQ process if configured
$N_{\text{Rep}}^{\text{AN}}$ (ack-NACK-NumRepetitions-r13)		1
ACK/NACK resource field		0
Reference channel for NPDCCH		R.NB.3 TDD for one NRS antenna port; R.NB.4 TDD for two NRS antenna ports
$\alpha_{\text{offset}}$ (npdcch-Offset-USS-r13)		0

## 8.12.1.2.1 Minimum Requirements for In-band

The requirements are specified in Table 8.12.1.2.1-2, with the addition of the parameters in Table 8.12.1.2.1-1 and the downlink physical channel setup according to Annex C.3.2 and C.3.6. The purpose of these tests is to verify the performance.

Table 8.12.1.2.1-1: Test Parameters for NPDSCH under In-band

Parameter	Unit	Test 1, 2
Downlink power allocation of LTE signal	$\rho_A$	dB
	$\rho_B$	dB
	$\sigma$	dB
$N_{oc}$ at antenna port	$N_{oc1}$	dBm/15kHz
	$N_{oc2}$	dBm/15kHz
LTE CRS port number (eutra-NumCRS-Ports-r13)		4
NPDCCH repetition number	subframe	8 for Test 1; 16 for Test 2; 128 for Test 3.
$R_{\max}$ ( $n_{pdccch-NumRepetitions-r13}$ )	subframe	8 for Test 1; 16 for Test 2; 128 for Test 3.
$G$ ( $n_{PDCCCH-startSF-USS-r13}$ )		4
Note 1: $P_B = 1$ . Note 2: This noise is applied to all subframes from the end of the NPDCCH to the end of the following NPDSCH transmission; Note 3: This noise is applied to all subframes from the end of the NPDSCH to the end of the following NPDCCH transmission.		

Table 8.12.1.2.2: Minimum performance under In-band with 2 NRS ports

Test number	Bandwidth	Carrier Type	Reference Channel	Repetition number	Propagation Condition	Correlation Matrix and Antenna Configuration	Reference value		UE Category
							Fraction of Maximum Throughput (%)	SNR (dB)	
1	200kHz	Anchored	R.NB.5 TDD	1	EPA5	2x1 Low	70%	6.9	NB1, NB2
2	200kHz	Anchored	R.NB.5 TDD	32	EPA5	2x1 Low	70%	-4.8	NB1, NB2
3	200kHz	Non-anchored	R.NB.5-1 TDD	256	ETU1	2x1 Low	70%	-9.8	NB1, NB2

## 8.12.1.2.2 Minimum Requirements for Standalone/Guard-band

The requirements are specified in Table 8.12.1.2.2-2, with the addition of the parameters in Table 8.12.1.2.2-1 and the downlink physical channel setup according to Annex C.3.6. The purpose of these tests is to verify the performance.

Table 8.12.1.2.2-1: Test Parameters for NPDSCH under Standalone/Guard-band

Parameter	Unit	Test 1, 2
$N_{oc}$ at antenna port	$N_{oc1}$	dBm/15kHz
	$N_{oc2}$	dBm/15kHz
NPDCCH repetition number	subframe	32 for Test 1; 256 for Test 2.
$R_{\max}$ ( $n_{pdccch-NumRepetitions-r13}$ )	subframe	32 for Test 1; 256 for Test 2.
$G$ ( $n_{PDCCCH-startSF-USS-r13}$ )		4
Note 1: This noise is applied to all subframes from the end of the NPDCCH to the end of the following NPDSCH transmission; Note 2: This noise is applied to all subframes from the end of the NPDSCH to the end of the following NPDCCH transmission.		

**Table 8.12.1.2.2-2: Minimum performance for NPDSCH under Standalone/Guard-band with 1 NRS port**

Test number	Bandwidth	Carrier Type	Reference Channel	Repetition number	Propagation condition	Number of NRS ports	Antenna Configuration	Reference value		UE Category
								Fraction of Maximum Throughput (%)	SNR (dB)	
1	200kHz	Anchor	R.NB.6 TDD	32	EPA5	1	1x1	70%	-3.4	NB1, NB2
2	200kHz	Non-anchor	R.NB.6-1 TDD	256	ETU1	1	1x1	70%	-10.2	NB1, NB2

**8.12.1.2.3 Minimum Requirements for Standalone for UE Category NB2**

The requirements are specified in Table 8.12.1.2.3-2, with the addition of the parameters in Table 8.12.1.2.3-1 and the downlink physical channel setup according to Annex C.3.6. The purpose of these tests is to verify the NPDSCH performance.

**Table 8.12.1.2.3-1: Test Parameters for NPDSCH under Standalone**

Parameter	Unit	Test 1
$N_{oc}$ at antenna port	$N_{oc1}$	-93 (Note 1)
	$N_{oc2}$	-96 (Note 2)
NPDCCH repetition number	subframe	4 for Test 1
$R_{max}$ ( $n_{pdccch-NumRepetitions-r13}$ )	subframe	8 for Test 1
$G$ ( $n_{PDCCCH-startSF-USS-r13}$ )		4
Note 1: This noise is applied to all subframes from the end of the NPDCCH to the end of the following NPDSCH transmission;		
Note 2: This noise is applied to all subframes from the end of the NPDSCH to the end of the following NPDCCH transmission.		

**Table 8.12.1.2.3-2: Minimum performance for NPDSCH under Standalone with 1 NRS port**

Test number	Bandwidth	Carrier Type	Reference Channel	Repetition number	Propagation condition	Number of NRS ports	Antenna Configuration	Reference value		UE Category
								Fraction of Maximum Throughput (%)	SNR (dB)	
1	200kHz	Non-anchor	R.NB.7 TDD	1	EPA5	1	1x1	70%	9.4	NB2

**8.12.2 NPDCCH**

The receiver characteristics of the NPDCCH are determined by the probability of miss-detection of the Downlink Scheduling Grant (Pm-dsg).

**8.12.2.1 Half-duplex FDD**

The parameters specified in Table 8.12.2.1-1 and Table 8.12.2.1-2 are valid for all half-duplex FDD tests unless otherwise stated.

Table 8.12.2.1-1: Test Parameters for NPDCCH

Parameter	Unit	Single antenna port	Transmit diversity
Narrowband physical layer Cell ID		0	0
$N_{oc}$ at antenna port	dBm/15kHz	-98	-98
Cyclic prefix		Normal	Normal
Number of CRS ports for in-band deployment mode		4	4
NPDCCH starting position ( <i>extraControlRegionSize-r13</i> ) (Note 1)		3	3
Maximum number of repetitions $R_{max}$ ( <i>npdcch-NumRepetitions-r13</i> )		128 for Test 1; 1024 for Test 2.	64 for Test 1; 512 for Test 2.
NPDCCH start subframe $G$ ( <i>npdcch-startSF-USS-r13</i> )		2 for test 1, 1.5 for test 2	2 for test 1, 1.5 for test 2
NPDCCH fractional period offset of starting subframe $\alpha_{offset}$ ( <i>npdcch-Offset-USS-r13</i> )		0	0
NB-IoT downlink subframe bitmap for anchor carrier ( <i>downlinkBitmap-r13</i> )		Not configured	Not configured
NB-IoT downlink subframe bitmap for non-anchor carrier ( <i>downlinkBitmapNonAnchor-r13</i> )		Not configured	Not configured
Downlink gap configuration for anchor carrier ( <i>dl-Gap-r13</i> )		Not configured	Not configured
Downlink gap configuration for non-anchor carrier ( <i>dl-GapNonAnchor-r13</i> )		Not configured	Not configured
Unused REs or RBs (Note 1)		OCNG	OCNG
OCNG pattern		NB.OP.1	NB.OP.1

NOTE 1: Applicable only for in-band deployment mode.

Table 8.12.2.1-2: Test Parameters of related NPDSCH and NPUSCH format 2 configurations

Parameter	Unit	Value
Scheduling delay field ( $I_{Delay}$ )		0
NPDSCH Repetition number		1
$N_{oc}$ at antenna port for NPDSCH	dBm/15kHz	-98
$N_{Rep}^{AV}$ ( <i>ack-NACK-NumRepetitions-r13</i> )		1
ACK/NACK resource field		0
Reference channel for NPDSCH		R.NB.6 FDD and R.NB.6-1 FDD for one NRS antenna port; R.NB.5 FDD and R.NB.5-1 FDD for two NRS antenna ports

### 8.12.2.1.1 Single-antenna performance

For the parameters specified in Table 8.12.2.1.1-1 the average probability of a missed downlink scheduling grant ( $P_{m-dsg}$ ) shall be below the specified value in Table 8.12.2.1.1-1. The downlink physical channel setup is in accordance with Annex C.3.6.

Table 8.12.2.1.1-1: Minimum performance NPDCCH

Test number	Deployment mode	Repetition number (R)	Carrier Type	Reference Channel	Propagation Condition	Number of NRS ports	Antenna Configuration	Reference value		UE Category
								Pm-dsg (%)	SNR (dB)	
1	Stand-alone/Guard-band	128	Anchor	R.NB.3 FDD	EPA5	1	1x1	1	-4.9	NB1, NB2
2	Stand-alone/Guard-band	1024	Non-anchor	R.NB.3 FDD	ETU1	1	1x1	1	-11.4	NB1, NB2

## 8.12.2.1.2 Transmit diversity performance

For the parameters specified in Table 8.12.2.1.2-1 the average probability of a missed downlink scheduling grant (Pm-dsg) shall be below the specified value in Table 8.12.2.1.2-1. The downlink physical channel setup is in accordance with Annex C.3.6.

Table 8.12.2.1.2-1: Minimum performance NPDCCH

Test number	Deployment mode	Repetition number (R)	Carrier Type	Reference Channel	Propagation Condition	Number of NRS ports	Antenna Configuration and correlation matrix	Reference value		UE Category
								Pm-dsg (%)	SNR (dB)	
1	In-band	64	Anchor	R.NB.4 FDD	EPA5	2	2x1 Low	1	-3.9	NB1, NB2
2	In-band	512	Non-anchor	R.NB.4 FDD	ETU1	2	2x1 Low	1	-10.0	NB1, NB2

## 8.12.2.2 TDD

The parameters specified in Table 8.12.2.2-1 and Table 8.12.2.2-2 are valid for all TDD tests unless otherwise stated.

Table 8.12.2.2-1: Test Parameters for NPDCCH

Parameter	Unit	Single antenna port	Transmit diversity
Uplink downlink configuration (Note 1)		4	4
Special subframe configuration (Note 2)		4	4
Narrowband physical layer Cell ID		0	0
$N_{oc}$ at antenna port	dBm/15kHz	-98	-98
Cyclic prefix		Normal	Normal
Number of CRS ports for in-band deployment mode		4	4
NPDCCH starting position ( <i>euTraControlRegionSize-r13</i> ) (Note 1)		2	2
Maximum number of repetitions $R_{max}$ ( <i>npdcch-NumRepetitions-r13</i> )		128 for Test 1; 1024 for Test 2.	64 for Test 1; 512 for Test 2.
NPDCCH start subframe $\bar{G}$ ( <i>npdcch-startSF-USS-r13</i> )		4	4
NPDCCH fractional period offset of starting subframe $\alpha_{offset}$ ( <i>npdcch-Offset-USS-r13</i> )		0	0
NB-IoT downlink subframe bitmap for anchor carrier ( <i>downlinkBitmap-r13</i> )		Not configured	Not configured
NB-IoT downlink subframe bitmap for non-anchor carrier ( <i>downlinkBitmapNonAnchor-r13</i> )		Not configured	Not configured
Downlink gap configuration for anchor carrier ( <i>dl-Gap-r13</i> )		Not configured	Not configured
Downlink gap configuration for non-anchor carrier ( <i>dl-GapNonAnchor-r13</i> )		Not configured	Not configured
Unused REs or RBs (Note 1)		OCNG	OCNG
OCNG pattern		NB.OP.1	NB.OP.1

NOTE 1: Applicable only for in-band deployment mode.

Table 8.12.2.2-2: Test Parameters of related NPDSCH and NPUSCH format 2 configurations

Parameter	Unit	Value
Scheduling delay field ( $I_{Delay}$ )		0
NPDSCH Repetition number		1
$N_{oc}$ at antenna port for NPDSCH	dBm/15kHz	-98
$N_{Rep}^{AV}$ ( <i>ack-NACK-NumRepetitions-r13</i> )		1
ACK/NACK resource field		0
Reference channel for NPDSCH		R.NB.6 TDD and R.NB.6-1 TDD for one NRS antenna port; R.NB.5 TDD and R.NB.5-1 TDD for two NRS antenna ports

### 8.12.2.2.1 Single-antenna performance

For the parameters specified in Table 8.12.2.2.1-1 the average probability of a missed downlink scheduling grant ( $P_{m-dsg}$ ) shall be below the specified value in Table 8.12.2.2.1-1. The downlink physical channel setup is in accordance with Annex C.3.6.

**Table 8.12.2.2.1-1: Minimum performance NPDCCH**

Test number	Deployment mode	Repetition number (R)	Carrier Type	Reference Channel	Propagation Condition	Number of NRS ports	Antenna Configuration	Reference value		UE Category
								$P_{m-dsg}$ (%)	SNR (dB)	
1	Stand-alone/Guard-band	128	Anchor	R.NB.3 TDD	EPA5	1	1x1	1	-4.9	NB1, NB2
2	Stand-alone/Guard-band	1024	Non-anchor	R.NB.3 TDD	ETU1	1	1x1	1	-11.4	NB1, NB2

### 8.12.2.2.2 Transmit diversity performance

For the parameters specified in Table 8.12.2.2.2-1 the average probability of a missed downlink scheduling grant ( $P_{m-dsg}$ ) shall be below the specified value in Table 8.12.2.2.2-1. The downlink physical channel setup is in accordance with Annex C.3.6.

**Table 8.12.2.2.2-1: Minimum performance NPDCCH**

Test number	Deployment mode	Repetition number (R)	Carrier Type	Reference Channel	Propagation Condition	Number of NRS ports	Antenna Configuration and correlation matrix	Reference value		UE Category
								$P_{m-dsg}$ (%)	SNR (dB)	
1	In-band	64	Anchor	R.NB.4 TDD	EPA5	2	2x1 Low	1	-3.9	NB1, NB2
2	In-band	512	Non-anchor	R.NB.4 TDD	ETU1	2	2x1 Low	1	-10.0	NB1, NB2

### 8.12.3 Demodulation of NPBCH

The receiver characteristics of the NPBCH are determined by the probability of miss-detection of the NPBCH ( $P_{m-bch}$ ), which is defined as

$$P_{m-bch} = 1 - \frac{A}{B}$$

For the performance with single a NPBCH TTI decoding, A is the number of correctly decoded MIB-NB PDUs and B is the number of transmitted MIB-NB PDUs.

For the performance with multiple NPBCH TTIs decoding, A is the number of 5120ms durations consisting of contiguous NPBCH TTIs where there is at least one correctly decoded MIB-NB PDU, and B is the number of 5120ms durations consisting of contiguous NPBCH TTIs during the test.

## 8.12.3.1 HD-FDD

**Table 8.12.3.1-1: Test Parameters for NPBCH**

Parameter		Unit	Single antenna port	Transmit diversity
Downlink power allocation	NPBCH_RA	dB	0	-3
	NPBCH_RB	dB	0	-3
$N_{oc}$ at antenna port		dBm/15kHz	-98	-98
Cyclic prefix			Normal	Normal
Cell ID			0	0

## 8.12.3.1.1 Single-antenna port performance with single NPBCH TTI

For the parameters specified in Table 8.12.3.1-1 the average probability of a miss-detecting NPBCH (Pm-bch) shall be below the specified value in Table 8.12.3.1.1-1. The downlink physical setup is in accordance with Annex C.3.6.

**Table 8.12.3.1.1-1: Minimum performance NPBCH**

Test number	Bandwidth	Reference Channel	Propagation Condition	Antenna configuration	Reference value		UE Category
					Pm-bch (%)	SNR (dB)	
1	200 KHz	R.NB1.1	EPA1	1 x 1	1	-2.0	NB1, NB2

## 8.12.3.1.2 Transmit diversity performance

## 8.12.3.1.2.1 Minimum Requirement 2 Tx Antenna Port with multiple NPBCH TTIs

For the parameters specified in Table 8.12.3.1-1 the average probability of a miss-detected NPBCH (Pm-bch) shall be below the specified value in Table 8.12.3.1.2.1-1. The downlink physical setup is in accordance with Annex C.3.6.

**Table 8.12.3.1.2.1-1: Minimum performance NPBCH**

Test number	Bandwidth	Reference Channel	Propagation Condition	Antenna configuration and correlation Matrix	Reference value		UE Category
					Pm-bch (%)	SNR (dB)	
1	200 KHz	R.NB1.2	EPA1	2 x 1 Low	1	-11.5	NB1, NB2

## 8.12.3.2 TDD

**Table 8.12.3.2-1: Test Parameters for NPBCH TDD**

Parameter		Unit	Single antenna port	Transmit diversity
Downlink power allocation	NPBCH_RA	dB	0	-3
	NPBCH_RB	dB	0	-3
$N_{oc}$ at antenna port		dBm/15kHz	-98	-98
Cyclic prefix			Normal	Normal
Cell ID			0	0
Uplink downlink configuration (Note 1)			4	4
Special subframe configuration (Note 2)			4	4
Note 1: as specified in Table 4.2-2 in TS 36.211 [4].				
Note 2: as specified in Table 4.2-1 in TS 36.211 [4].				



### 8.12.3.2.1 Single-antenna port performance with single NPBCH TTI

For the parameters specified in Table 8.12.3.2-1 the average probability of a miss-detecting NPBCH (P<sub>m-bch</sub>) shall be below the specified value in Table 8.12.3.2.1-1. The downlink physical setup is in accordance with Annex C.3.6.

**Table 8.12.3.2.1-1: Minimum performance NPBCH**

Test number	Bandwidth	Reference Channel	Propagation Condition	Antenna configuration	Reference value		UE Category
					P <sub>m-bch</sub> (%)	SNR (dB)	
1	200 KHz	R.NB1.1	EPA1	1 x 1	1	-2.0	NB1, NB2

### 8.12.3.2.2 Transmit diversity performance

#### 8.12.3.2.2.1 Minimum Requirement 2 Tx Antenna Port with multiple NPBCH TTIs

For the parameters specified in Table 8.12.3.2-1 the average probability of a miss-detected NPBCH (P<sub>m-bch</sub>) shall be below the specified value in Table 8.12.3.2.2.1-1. The downlink physical setup is in accordance with Annex C.3.6.

**Table 8.12.3.2.2.1-1: Minimum performance NPBCH**

Test number	Bandwidth	Reference Channel	Propagation Condition	Antenna configuration and correlation Matrix	Reference value		UE Category
					P <sub>m-bch</sub> (%)	SNR (dB)	
1	200 KHz	R.NB1.2	EPA1	2 x 1 Low	1	-11.5	NB1, NB2

## 8.13 Demodulation of PDSCH CA and DC(4 receiver antenna ports)

### 8.13.1 FDD (CA and DC)

The parameters specified in Table 8.13.1-1 are valid for all FDD CA and DC tests unless otherwise stated.

**Table 8.13.1-1: Common Test Parameters (FDD)**

Parameter	Unit	Value
Inter-TTI Distance		1
Number of HARQ processes per component carrier	Processes	8
Maximum number of HARQ transmission		4
Redundancy version coding sequence		{0,1,2,3} for QPSK and 16QAM {0,0,1,2} for 64QAM and 256QAM
Number of OFDM symbols for PDCCH per component carrier	OFDM symbols	4 for 1.4 MHz bandwidth, 3 for 3 MHz and 5 MHz bandwidths, 2 for 10 MHz, 15 MHz and 20 MHz bandwidths unless otherwise stated
Cyclic Prefix		Normal
Cell_ID		0
Cross carrier scheduling		Not configured

#### 8.13.1.1 Closed-loop spatial multiplexing performance

##### 8.13.1.1.1 Minimum Requirement Multi-Layer Spatial Multiplexing 4 Tx Antenna Port

The purpose of these tests is to verify the closed loop rank-two performance with frequency selective precoding.

For CA with 2 DL CCs, the requirements are specified in Table 8.13.1.1.1-3, based on single carrier requirement specified in Table 8.13.1.1.1-2, with the addition of the parameters in Table 8.13.1.1.1-1 and the downlink physical channel setup according to Annex C.3.2.

For CA with 3 DL CCs, the requirements are specified in Table 8.13.1.1.1-4, based on single carrier requirement specified in Table 8.13.1.1.1-2, with the addition of the parameters in Table 8.13.1.1.1-1 and the downlink physical channel setup according to Annex C.3.2.

For CA with 4 DL CCs, the requirements are specified in Table 8.13.1.1.1-5, based on single carrier requirement specified in Table 8.13.1.1.1-2, with the addition of the parameters in Table 8.13.1.1.1-1 and the downlink physical channel setup according to Annex C.3.2.

For CA with 5 DL CCs, the requirements are specified in Table 8.13.1.1.1-6, based on single carrier requirement specified in Table 8.13.1.1.1-2, with the addition of the parameters in Table 8.13.1.1.1-1 and the downlink physical channel setup according to Annex C.3.2.

The test coverage for different number of component carriers is defined in 8.1.2.4.

**Table 8.13.1.1.1-1: Test Parameters for Multi-Layer Spatial Multiplexing (FRC) for CA**

Parameter	Unit	Value
Downlink power allocation	$\rho_A$	dB
	$\rho_B$	dB
	$\sigma$	dB
$N_{oc}$ at antenna port	dBm/15kHz	-98
Precoding granularity	PRB	4 for 3MHz and 5MHz CCs, 6 for 10MHz CCs, 8 for 15MHz and 20MHz CCs
PMI delay (Note 2)	ms	8
Reporting interval	ms	1
Reporting mode		PUSCH 1-2
CodeBookSubsetRestriction bitmap		00000000000000000000000000000000 001111111111111111111111000000000000 0000
CSI request field (Note 3)		'10'
PDSCH transmission mode		4
Note 1: $P_B = 1$ . Note 2: If the UE reports in an available uplink reporting instance at subframe SF#n based on PMI estimation at a downlink SF not later than SF#(n-4), this reported PMI cannot be applied at the eNB downlink before SF#(n+4). Note 3: Multiple CC-s under test are configured as the 1 <sup>st</sup> set of serving cells by higher layers. Note 4: ACK/NACK bits are transmitted using PUSCH with PUCCH format 1b with channel selection configured for Tests in Table 8.13.1.1.1-3, and with PUCCH format 3 for Tests in Table 8.13.1.1.1-4, Table 8.13.1.1.1-5 and Table 8.13.1.1.1-6. Note 5: The same PDSCH transmission mode is applied to each component carrier.		

Table 8.13.1.1.1-2: Single carrier performance for multiple CA configurations

Band - width	Reference channel		OCNG pattern	Propagation condition	Correlation matrix and antenna config.		Reference value		
							Fraction of maximum throughput (%)	SNR (dB)	
	2Rx CC	4Rx CC			2Rx CC	4Rx CC			
1.4M Hz	R.14-4 FDD	R.14-4 FDD	OP.1 FDD	EVA5	4x2 Low	4x4 Low	70	10.4	7.5
3MHz	R.14-5 FDD	R.14-5 FDD	OP.1 FDD	EVA5	4x2 Low	4x4 Low	70	9.5	5.1
5MHz	R.14-6 FDD	R.14-6 FDD	OP.1 FDD	EVA5	4x2 Low	4x4 Low	70	9.5	5.2
10 MHz	R.14 FDD	R.14 FDD	OP.1 FDD	EVA5	4x2 Low	4x4 Low	70	10.1	5.7
15M Hz	R.14-7 FDD	R.14-7 FDD	OP.1 FDD	EVA5	4x2 Low	4x4 Low	70	10.1	5.6
20M Hz	R.14-3 FDD	R.14-3 FDD	OP.1 FDD	EVA5	4x2 Low	4x4 Low	70	10.3	5.6

Table 8.13.1.1.1-3: Minimum performance (FRC) based on single carrier performance for CA with 2 DL CCs

Test num.	CA Band-width combination	Requirement	UE category
1	2x10 MHz	As specified in Table 8.13.1.1.1-2 per CC depending on either 2Rx CC or 4Rx CC	≥5
2	2x20 MHz	As specified in Table 8.13.1.1.1-2 per CC depending on either 2Rx CC or 4Rx CC	≥5
3	2x5 MHz	As specified in Table 8.13.1.1.1-2 per CC depending on either 2Rx CC or 4Rx CC	≥5
4	15MHz+5MHz	As specified in Table 8.13.1.1.1-2 per CC depending on either 2Rx CC or 4Rx CC	≥5
5	10MHz+5MHz	As specified in Table 8.13.1.1.1-2 per CC depending on either 2Rx CC or 4Rx CC	≥5
Note 1: The applicability of requirements for different CA configurations and bandwidth combination sets is defined in 8.1.2.6.			

**Table 8.13.1.1.1-4: Minimum performance (FRC) based on single carrier performance for CA with 3 DL CCs**

Test num.	CA Band-width combination	Requirement	UE category
1	3x20MHz	As specified in Table 8.13.1.1.1-2 per CC depending on either 2Rx CC or 4Rx CC	≥5
2	20MHz+20MHz+15MHz	As specified in Table 8.13.1.1.1-2 per CC depending on either 2Rx CC or 4Rx CC	≥5
3	20MHz+20MHz+10MHz	As specified in Table 8.13.1.1.1-2 per CC depending on either 2Rx CC or 4Rx CC	≥5
4	20MHz+15MHz+15MHz	As specified in Table 8.13.1.1.1-2 per CC depending on either 2Rx CC or 4Rx CC	≥5
5	20MHz+15MHz+10MHz	As specified in Table 8.13.1.1.1-2 per CC depending on either 2Rx CC or 4Rx CC	≥5
6	20MHz+10MHz+10MHz	As specified in Table 8.13.1.1.1-2 per CC depending on either 2Rx CC or 4Rx CC	≥5
7	15MHz+15MHz+10MHz	As specified in Table 8.13.1.1.1-2 per CC depending on either 2Rx CC or 4Rx CC	≥5
8	20MHz+10MHz+5MHz	As specified in Table 8.13.1.1.1-2 per CC depending on either 2Rx CC or 4Rx CC	≥5
9	20MHz+15MHz+5MHz	As specified in Table 8.13.1.1.1-2 per CC depending on either 2Rx CC or 4Rx CC	≥5
10	10MHz+10MHz+5MHz	As specified in Table 8.13.1.1.1-2 per CC depending on either 2Rx CC or 4Rx CC	≥5
11	5MHz+5MHz+20MHz	As specified in Table 8.13.1.1.1-2 per CC depending on either 2Rx CC or 4Rx CC	≥5
12	3x10MHz	As specified in Table 8.13.1.1.1-2 per CC depending on either 2Rx CC or 4Rx CC	≥5
13	5MHz+5MHz+10MHz	As specified in Table 8.13.1.1.1-2 per CC depending on either 2Rx CC or 4Rx CC	≥5
Note 1:	The applicability of requirements for different CA configurations and bandwidth combination sets is defined in 8.1.2.6.		

**Table 8.13.1.1.1-5: Minimum performance (FRC) based on single carrier performance for CA with 4 DL CCs**

Test num.	CA Band-width combination	Requirement	UE category
1	4x20MHz	As specified in Table 8.13.1.1.1-2 per CC depending on either 2Rx CC or 4Rx CC	≥8
2	10MHz+20MHz+20MHz+20MHz	As specified in Table 8.13.1.1.1-2 per CC depending on either 2Rx CC or 4Rx CC	≥8
3	10MHz+10MHz+20MHz+20MHz	As specified in Table 8.13.1.1.1-2 per CC depending on either 2Rx CC or 4Rx CC	≥8
4	5MHz+10MHz+20MHz+20MHz	As specified in Table 8.13.1.1.1-2 per CC depending on either 2Rx CC or 4Rx CC	≥8
5	5MHz+10MHz+10MHz+20MHz	As specified in Table 8.13.1.1.1-2 per CC depending on either 2Rx CC or 4Rx CC	≥8
6	15+3x20MHz	As specified in Table 8.13.1.1.1-2 per CC depending on either 2Rx CC or 4Rx CC	≥8
7	2x15+2x20MHz	As specified in Table 8.13.1.1.1-2 per CC depending on either 2Rx CC or 4Rx CC	≥8
8	10+15+2x20MHz	As specified in Table 8.13.1.1.1-2 per CC depending on either 2Rx CC or 4Rx CC	≥8
9	3x10+20MHz	As specified in Table 8.13.1.1.1-2 per CC depending on either 2Rx CC or 4Rx CC	≥8
10	2x5+2x20MHz	As specified in Table 8.13.1.1.1-2 per CC depending on either 2Rx CC or 4Rx CC	≥8
11	2x5+10+20MHz	As specified in Table 8.13.1.1.1-2 per CC depending on either 2Rx CC or 4Rx CC	≥8
12	4x10MHz	As specified in Table 8.13.1.1.1-2 per CC depending on either 2Rx CC or 4Rx CC	≥8

NOTE 1: The applicability of requirements for different CA configurations and bandwidth combination sets is defined in 8.1.2.6.

**Table 8.13.1.1.1-6: Minimum performance (FRC) based on single carrier performance for CA with 5 DL CCs**

Test num.	CA Band-width combination	Requirement	UE category
1	5x20MHz	As specified in Table 8.13.1.1.1-2 per CC depending on either 2Rx CC or 4Rx CC	8, ≥11
2	15MHz+4x20MHz	As specified in Table 8.13.1.1.1-2 per CC depending on either 2Rx CC or 4Rx CC	8, ≥11
3	10MHz+4x20MHz	As specified in Table 8.13.1.1.1-2 per CC depending on either 2Rx CC or 4Rx CC	8, ≥11
4	2x10MHz+3x20MHz	As specified in Table 8.13.1.1.1-2 per CC depending on either 2Rx CC or 4Rx CC	8, ≥11
5	5MHz+10MHz+3x20MHz	As specified in Table 8.13.1.1.1-2 per CC depending on either 2Rx CC or 4Rx CC	8, ≥11
6	3x10MHz+2x20MHz	As specified in Table 8.13.1.1.1-2 per CC depending on either 2Rx CC or 4Rx CC	8, ≥11
7	4x10MHz+20MHz	As specified in Table 8.13.1.1.1-2 per CC depending on either 2Rx CC or 4Rx CC	8, ≥11

NOTE 1: The applicability of requirements for different CA configurations and bandwidth combination sets is defined in 8.1.2.6.

### 8.13.1.1.2 Minimum Requirement Multi-Layer Spatial Multiplexing 4 Tx Antenna Port for dual connectivity

For dual connectivity the requirements are specified in Table 8.13.1.1.2-3 for 2DL CCs and Table 8.13.1.1.2-4 for 3DL CCs, based on single carrier requirement specified in Table 8.13.1.1.2-2, with the addition of the parameters in Table 8.13.1.1.2-1 and the downlink physical channel setup according to Annex C.3.2. The purpose of these tests is to verify the closed loop rank-two performance with wideband and frequency selective precoding by using dual connectivity transmission.

Table 8.13.1.1.2-1: Test Parameters for Multi-Layer Spatial Multiplexing (FRC) for dual connectivity

Parameter	Unit	Values
Downlink power allocation	$\rho_A$	dB
	$\rho_B$	dB
	$\sigma$	dB
$N_{oc}$ at antenna port	dBm/15kHz	-98
Precoding granularity	PRB	6 for 1.4MHz, 4 for 3MHz and 5MHz CCs, 6 for 10MHz CCs, and 8 for 15MHz CCs and 20MHz CCs
PMI delay (Note 2)	ms	8
Reporting interval	ms	1
Reporting mode		PUSCH 1-2
CodeBookSubsetRestriction bitmap		00000000000000000000000000000000 0000111111111111111111111111111100000000 00000000
PDSCH transmission mode		4
ACK/NACK transmission		Separate ACK/NACK feedbacks with PUCCH format 1b on the MCG and SCG
CSI feedback		Separate PUSCH feedbacks on the MCG and SCG
Time offset between MCG CC and SCG CC	$\mu$ s	0 for UE under test supporting synchronous dual connectivity; 334 for UE under test supporting both asynchronous and synchronous dual connectivity (Note 4)
Note 1: $P_B = 1$ . Note 2: If the UE reports in an available uplink reporting instance at subframe SF#n based on PMI estimation at a downlink SF not later than SF#(n-4), this reported PMI cannot be applied at the eNB downlink before SF#(n+4). Note 3: The same PDSCH transmission mode is applied to each component carrier. Note 4: As defined in TS36.300 [11]. Note 5: If the UE supports both SCG bearer and Split bearer, the SCG bearer is configured.		

Table 8.13.1.1.2-2: Single carrier performance for multiple DC configurations

Band - width	Reference channel		OCNG pattern	Propagation condition	Correlation matrix and antenna config.		Reference value		
	2Rx CC	4Rx CC			2Rx CC	4Rx CC	Fraction of maximum throughput (%)	SNR (dB)	
								2Rx CC	4Rx CC
1.4M Hz	R.14-4 FDD	R.14-4 FDD	OP.1 FDD	EVA5	4x2 Low	4x4 Low	70	10.4	7.5
3MHz	R.14-5 FDD	R.14-5 FDD	OP.1 FDD	EVA5	4x2 Low	4x4 Low	70	9.5	5.1
5MHz	R.14-6 FDD	R.14-6 FDD	OP.1 FDD	EVA5	4x2 Low	4x4 Low	70	9.5	5.2
10 MHz	R.14 FDD	R.14 FDD	OP.1 FDD	EVA5	4x2 Low	4x4 Low	70	10.1	5.7
15M Hz	R.14-7 FDD	R.14-7 FDD	OP.1 FDD	EVA5	4x2 Low	4x4 Low	70	10.1	5.6
20M Hz	R.14-3 FDD	R.14-3 FDD	OP.1 FDD	EVA5	4x2 Low	4x4 Low	70	10.3	5.6

**Table 8.13.1.1.2-3: Minimum performance Multi-Layer Spatial Multiplexing (FRC) for dual connectivity with 2 DL CCs**

Test num.	Band-width combination	Requirement	UE category
1	2x20 MHz	As specified in Table 8.13.1.1.2-2 per CC depending on either 2Rx CC or 4Rx CC	≥5
2	15+20 MHz	As specified in Table 8.13.1.1.2-2 per CC depending on either 2Rx CC or 4Rx CC	≥5
3	10+20MHz	As specified in Table 8.13.1.1.2-2 per CC depending on either 2Rx CC or 4Rx CC	≥5
4	2x15 MHz	As specified in Table 8.13.1.1.2-2 per CC depending on either 2Rx CC or 4Rx CC	≥5
5	2x10 MHz	As specified in Table 8.13.1.1.2-2 per CC depending on either 2Rx CC or 4Rx CC	≥3
6	15+5 MHz	As specified in Table 8.13.1.1.2-2 per CC depending on either 2Rx CC or 4Rx CC	≥3
7	10+15 MHz	As specified in Table 8.13.1.1.2-2 per CC depending on either 2Rx CC or 4Rx CC	≥5
Note 1: The OCNG pattern applies for each CC.			
Note 2: The applicability of requirements for different dual connectivity configurations and bandwidth combination sets is defined in 8.1.2.6.			

**Table 8.13.1.1.2-4: Minimum performance Multi-Layer Spatial Multiplexing (FRC) for dual connectivity with 3DL CCs**

Test num.	Band-width combination	Requirement	UE category
1	20+20+15MHz	As specified in Table 8.13.1.1.2-2 per CC depending on either 2Rx CC or 4Rx CC	≥5
2	20+15+15MHz	As specified in Table 8.13.1.1.2-2 per CC depending on either 2Rx CC or 4Rx CC	≥5
3	3x20 MHz	As specified in Table 8.13.1.1.2-2 per CC depending on either 2Rx CC or 4Rx CC	≥5
4	20+20+10 MHz	As specified in Table 8.13.1.1.2-2 per CC depending on either 2Rx CC or 4Rx CC	≥5
5	20+15+10 MHz	As specified in Table 8.13.1.1.2-2 per CC depending on either 2Rx CC or 4Rx CC	≥5
6	20+10+10 MHz	As specified in Table 8.13.1.1.2-2 per CC depending on either 2Rx CC or 4Rx CC	≥5
7	15+15+10 MHz	As specified in Table 8.13.1.1.2-2 per CC depending on either 2Rx CC or 4Rx CC	≥5
Note 1: The OCNG pattern applies for each CC.			
Note 2: The applicability of requirements for different dual connectivity configurations and bandwidth combination sets is defined in 8.1.2.6.			

### 8.13.1.1.3 Minimum Requirement Multi-Layer Spatial Multiplexing 4 Tx Antenna Port with 256QAM

The purpose of these tests is to verify the closed loop rank-two performance with frequency selective precoding with 256QAM under CA.

For CA with 2 DL CCs, the requirements are specified in Table 8.13.1.1.3-3, based on single carrier requirement specified in Table 8.13.1.1.3-2, with the addition of the parameters in Table 8.13.1.1.3-1 and the downlink physical channel setup according to Annex C.3.2. The test coverage for different number of component carriers is defined in 8.1.2.4.

**Table 8.13.1.1.3-1: Test Parameters for Multi-Layer Spatial Multiplexing (FRC) for CA**

Parameter	Unit	Value	
Downlink power allocation	$\rho_A$	dB	-6
	$\rho_B$	dB	-6 (Note 1)
	$\sigma$	dB	3
$N_{oc}$ at antenna port	dBm/15kHz	-98	
Precoding granularity	PRB	4 for 3MHz and 5MHz CCs, 6 for 10MHz CCs, 8 for 15MHz and 20MHz CCs	
PMI delay (Note 2)	ms	8	
Reporting interval	ms	1	
Reporting mode		PUSCH 1-2	
CodeBookSubsetRestriction bitmap		00000000000000000000000000000000 00111111111111111111000000000000 0000	
CSI request field (Note 3)		'10'	
PDSCH transmission mode		4	
Note 1: $P_B = 1$ . Note 2: If the UE reports in an available uplink reporting instance at subframe SF#n based on PMI estimation at a downlink SF not later than SF#(n-4), this reported PMI cannot be applied at the eNB downlink before SF#(n+4). Note 3: Multiple CC-s under test are configured as the 1 <sup>st</sup> set of serving cells by higher layers. Note 4: ACK/NACK bits are transmitted using PUSCH with PUCCH format 1b with channel selection configured for Tests in Table 8.13.1.1.3-3. Note 5: The same PDSCH transmission mode is applied to each component carrier.			

**Table 8.13.1.1.3-2: Single carrier performance for multiple CA configurations**

Band - width	Reference channel		OCNG pattern	Propagation condition	Correlation matrix and antenna config.		Reference value		
							Fraction of maximum throughput (%)	SNR (dB)	
	2Rx CC	4Rx CC			2Rx CC	4Rx CC			
5MHz	R.72-1 FDD	R.72-1 FDD	OP.1 FDD	EPA5	4x2 Low	4x4 Low	70	23.4	19.3
10 MHz	R.72 FDD	R.72 FDD	OP.1 FDD	EPA5	4x2 Low	4x4 Low	70	21.6	18.0
15M Hz	R.72-2 FDD	R.72-2 FDD	OP.1 FDD	EPA5	4x2 Low	4x4 Low	70	21.7	17.4
20M Hz	R.72-3 FDD	R.72-3 FDD	OP.1 FDD	EPA5	4x2 Low	4x4 Low	70	21.8	17.5

**Table 8.13.1.1.3-3: Minimum performance (FRC) based on single carrier performance for CA with 2 DL CCs**

Test num.	CA Band-width combination	Requirement	UE category
1	2x10 MHz	As specified in Table 8.13.1.1.3-2 per CC depending on either 2Rx CC or 4Rx CC	≥5
2	2x20 MHz	As specified in Table 8.13.1.1.3-2 per CC depending on either 2Rx CC or 4Rx CC	≥5
3	2x5 MHz	As specified in Table 8.13.1.1.3-2 per CC depending on either 2Rx CC or 4Rx CC	≥5
4	15MHz+5MHz	As specified in Table 8.13.1.1.3-2 per CC depending on either 2Rx CC or 4Rx CC	≥5
5	10MHz+5MHz	As specified in Table 8.13.1.1.3-2 per CC depending on either 2Rx CC or 4Rx CC	≥5
Note 1: The applicability of requirements for different CA configurations and bandwidth combination sets is defined in 8.1.2.6.			



## 8.13.1.1.4 Minimum Requirement Four-Layer Spatial Multiplexing 4 Tx Antenna Port

The purpose of these tests is to verify the closed loop rank-four performance with wideband precoding with 4Tx and 4Rx under CA.

For CA with 2 DL CCs, the requirements are specified in Table 8.13.1.1.4-3, based on single carrier requirement specified in Table 8.13.1.1.4-2, with the addition of the parameters in Table 8.13.1.1.4-1 and the downlink physical channel setup according to Annex C.3.2. The test coverage for different number of component carriers is defined in 8.1.2.4.

**Table 8.13.1.1.4-1: Test Parameters for Four-Layer Spatial Multiplexing (FRC) for CA**

Parameter	Unit	Value	
Downlink power allocation	$\rho_A$	dB	-6
	$\rho_B$	dB	-6 (Note 1)
	$\sigma$	dB	0
$N_{oc}$ at antenna port	dBm/15kHz	-98	
Cell-specific reference signals		Antenna Ports 0,1,2,3	
Precoding granularity	PRB	25 for 5MHz CCs, 50 for 10MHz CCs, 75 for 15MHz and 100 for 20MHz CCs	
PMI delay (Note 2)	ms	8	
Reporting interval	ms	1	
Reporting mode		PUSCH 3-1	
CodeBookSubsetRestriction bitmap		0xFFFF000000000000	
CSI request field (Note 3)		'10'	
PDSCH transmission mode		4	
PDSCH rank		4	
Note 1: $P_B = 1$ .			
Note 2: If the UE reports in an available uplink reporting instance at subframe SF#n based on PMI estimation at a downlink SF not later than SF#(n-4), this reported PMI cannot be applied at the eNB downlink before SF#(n+4).			
Note 3: Multiple CC-s under test are configured as the 1 <sup>st</sup> set of serving cells by higher layers.			
Note 4: ACK/NACK bits are transmitted using PUSCH with PUCCH format 1b with channel selection			
Note 5: The same PDSCH transmission mode is applied to each component carrier.			

**Table 8.13.1.1.4-2: Single carrier performance for multiple CA configurations**

Bandwidth	Reference channel	OCNG pattern	Propagation condition	Correlation matrix and antenna config	Reference value	
					Fraction of maximum throughput (%)	SNR (dB)
5MHz	R.74-1 FDD	OP.1 FDD	EPA5	4x4 Low	70	14.1
10MHz	R.74 FDD	OP.1 FDD	EPA5	4x4 Low	70	14.9
15MHz	R.74-2 FDD	OP.1 FDD	EPA5	4x4 Low	70	14.3
20MHz	R.74-3 FDD	OP.1 FDD	EPA5	4x4 Low	70	14.4

**Table 8.13.1.1.4-3: Minimum performance (FRC) based on single carrier performance for CA with 2 DL CCs**

Test num.	CA Band-width combination	Requirement	UE category
1	2x10 MHz	As specified in Table 8.13.1.1.4-2 per CC	≥5
2	2x20 MHz	As specified in Table 8.13.1.1.4-2 per CC	≥5
3	2x5 MHz	As specified in Table 8.13.1.1.4-2 per CC	≥5
4	15MHz+5MHz	As specified in Table 8.13.1.1.4-2 per CC	≥5
5	10MHz+5MHz	As specified in Table 8.13.1.1.4-2 per CC	≥5
Note 1: The applicability of requirements for different CA configurations and bandwidth combination sets is defined in 8.1.2.6.			

## 8.13.1.2 Dual-Layer Spatial Multiplexing (User-Specific Reference Symbols)

### 8.13.1.2.1 Minimum Requirement Dual-Layer Spatial Multiplexing 2 Tx Antenna Port

For CA with 2 DL CCs, for dual-layer transmission on antenna ports 7 and 8 upon detection of a PDCCH with DCI format 2C, the requirements are specified in Table 8.13.1.2.1-3, based on single carrier requirement specified in Table 8.13.1.2.1-2, with the addition of the parameters in Table 8.13.1.2.1-1 and the downlink physical channel setup according to Annex C.3.2.

For CA with 3 DL CCs, for dual-layer transmission on antenna ports 7 and 8 upon detection of a PDCCH with DCI format 2C, the requirements are specified in Table 8.13.1.2.1-4, based on single carrier requirement specified in Table 8.13.1.2.1-2, with the addition of the parameters in Table 8.13.1.2.1-1 and the downlink physical channel setup according to Annex C.3.2.

For CA with 4 DL CCs, for dual-layer transmission on antenna ports 7 and 8 upon detection of a PDCCH with DCI format 2C, the requirements are specified in Table 8.13.1.2.1-5, based on single carrier requirement specified in Table 8.13.1.2.1-2, with the addition of the parameters in Table 8.13.1.2.1-1 and the downlink physical channel setup according to Annex C.3.2.

For CA with 5 DL CCs, for dual-layer transmission on antenna ports 7 and 8 upon detection of a PDCCH with DCI format 2C, the requirements are specified in Table 8.13.1.2.1-6, based on single carrier requirement specified in Table 8.13.1.2.1-2, with the addition of the parameters in Table 8.13.1.2.1-1 and the downlink physical channel setup according to Annex C.3.2.

The test coverage for different number of component carriers is defined in 8.1.2.4.

**Table 8.13.1.2.1-1: Test Parameters for Multi-Layer Spatial Multiplexing (FRC) for CA**

Parameter	Unit	Values	
Downlink power allocation	$\rho_A$	dB	0
	$\rho_B$	dB	0 (Note 1)
	$\sigma$	dB	-3
Cell-specific reference signals		Antenna ports 0 and 1	
Cell ID		0	
CSI reference signals		Antenna ports 15,16	
Beamforming model		Annex B.4.2	
CSI-RS periodicity and subframe offset $T_{\text{CSI-RS}} / \Delta_{\text{CSI-RS}}$	Subframes	5 / 2	
CSI reference signal configuration		8	
Zero-power CSI-RS configuration $l_{\text{CSI-RS}} / \text{ZeroPowerCSI-RS}$ bitmap	Subframes / bitmap	3 / 0010000000000000	
$N_{oc}$ at antenna port	dBm/15kHz	-98	
$\hat{E}_s / N_{oc}$		Reference Value in Table 8.13.1.2.1-2	
Symbols for unused PRBs		OCNG (Note 2)	
Number of allocated resource blocks (Note 2)	PRB	50	
Simultaneous transmission		No	
PDSCH transmission mode		9	
Note 1: $P_B = 1$			
Note 2: These physical resource blocks are assigned to an arbitrary number of virtual UEs with one PDSCH per virtual UE; the data transmitted over the OCNG PDSCHs shall be uncorrelated pseudo random data, which is QPSK modulated.			

**Table 8.13.1.2.1-2: Single carrier performance for multiple CA configurations**

Band - width	Reference channel		OCNG pattern	Propa- gation condi- tion	Correlation matrix and antenna config.		Reference value		
	2Rx CC	4Rx CC			2Rx CC	4Rx CC	Fraction of maximum throughpu t (%)	SNR (dB)	
								2Rx CC	4Rx CC
5MHz	R.51-2 FDD	R.51-2 FDD	OP.1 FDD	ETU5	2x2 Low	2x4 Low	70	14.2	9.0
10 MHz	R.51 FDD	R.51 FDD	OP.1 FDD	ETU5	2x2 Low	2x4 Low	70	13.7	8.8
15M Hz	R.51-3 FDD	R.51-3 FDD	OP.1 FDD	ETU5	2x2 Low	2x4 Low	70	13.6	8.7
20M Hz	R.51-4 FDD	R.51-4 FDD	OP.1 FDD	ETU5	2x2 Low	2x4 Low	70	14.3	8.8
Note 1: The propagation conditions for Cell 1 and Cell 2 are statistically independent.									
Note 2: Correlation matrix and antenna configuration parameters apply for each of Cell 1 and Cell 2.									
Note 3: SNR corresponds to $\hat{E}_s / N_{oc}$ of Cell 1.									

**Table 8.13.1.2. 1-3: Minimum performance (FRC) based on single carrier performance for CA with 2 DL CCs**

Test num.	CA Band-width combination	Requirement	UE category
1	2x10 MHz	As specified in Table 8.13.1.2.1-2 per CC depending on either 2Rx CC or 4Rx CC	≥5
2	2x20 MHz	As specified in Table 8.13.1.2.1-2 per CC depending on either 2Rx CC or 4Rx CC	≥5
3	2x5 MHz	As specified in Table 8.13.1.2.1-2 per CC depending on either 2Rx CC or 4Rx CC	≥5
4	15MHz+5MHz	As specified in Table 8.13.1.2.1-2 per CC depending on either 2Rx CC or 4Rx CC	≥5
5	10MHz+5MHz	As specified in Table 8.13.1.2.1-2 per CC depending on either 2Rx CC or 4Rx CC	≥5
Note 1: The applicability of requirements for different CA configurations and bandwidth combination sets is defined in 8.1.2.6.			

**Table 8.13.1.2.1-4: Minimum performance (FRC) based on single carrier performance for CA with 3 DL CCs**

Test num.	CA Band-width combination	Requirement	UE category
1	3x20MHz	As specified in Table 8.13.1.2.1-2 per CC depending on either 2Rx CC or 4Rx CC	≥5
2	20MHz+20MHz+15MHz	As specified in Table 8.13.1.2.1-2 per CC depending on either 2Rx CC or 4Rx CC	≥5
3	20MHz+20MHz+10MHz	As specified in Table 8.13.1.2.1-2 per CC depending on either 2Rx CC or 4Rx CC	≥5
4	20MHz+15MHz+15MHz	As specified in Table 8.13.1.2.1-2 per CC depending on either 2Rx CC or 4Rx CC	≥5
5	20MHz+15MHz+10MHz	As specified in Table 8.13.1.2.1-2 per CC depending on either 2Rx CC or 4Rx CC	≥5
6	20MHz+10MHz+10MHz	As specified in Table 8.13.1.2.1-2 per CC depending on either 2Rx CC or 4Rx CC	≥5
7	15MHz+15MHz+10MHz	As specified in Table 8.13.1.2.1-2 per CC depending on either 2Rx CC or 4Rx CC	≥5
8	20MHz+10MHz+5MHz	As specified in Table 8.13.1.2.1-2 per CC depending on either 2Rx CC or 4Rx CC	≥5
9	20MHz+15MHz+5MHz	As specified in Table 8.13.1.2.1-2 per CC depending on either 2Rx CC or 4Rx CC	≥5
10	10MHz+10MHz+5MHz	As specified in Table 8.13.1.2.1-2 per CC depending on either 2Rx CC or 4Rx CC	≥5
11	5MHz+5MHz+20MHz	As specified in Table 8.13.1.2.1-2 per CC depending on either 2Rx CC or 4Rx CC	≥5
12	3x10MHz	As specified in Table 8.13.1.2.1-2 per CC depending on either 2Rx CC or 4Rx CC	≥5
13	5MHz+5MHz+10MHz	As specified in Table 8.13.1.2.1-2 per CC depending on either 2Rx CC or 4Rx CC	≥5
Note 1: The applicability of requirements for different CA configurations and bandwidth combination sets is defined in 8.1.2.6.			

**Table 8.13.1.2.1-5: Minimum performance (FRC) based on single carrier performance for CA with 4 DL CCs**

Test num.	CA Band-width combination	Requirement	UE category
1	4x20MHz	As specified in Table 8.13.1.2.1-2 per CC depending on either 2Rx CC or 4Rx CC	≥8
2	10MHz+20MHz+20MHz+20MHz	As specified in Table 8.13.1.2.1-2 per CC depending on either 2Rx CC or 4Rx CC	≥8
3	10MHz+10MHz+20MHz+20MHz	As specified in Table 8.13.1.2.1-2 per CC depending on either 2Rx CC or 4Rx CC	≥8
4	5MHz+10MHz+20MHz+20MHz	As specified in Table 8.13.1.2.1-2 per CC depending on either 2Rx CC or 4Rx CC	≥8
5	5MHz+10MHz+10MHz+20MHz	As specified in Table 8.13.1.2.1-2 per CC depending on either 2Rx CC or 4Rx CC	≥8
6	15+3x20MHz	As specified in Table 8.13.1.2.1-2 per CC depending on either 2Rx CC or 4Rx CC	≥8
7	2x15+2x20MHz	As specified in Table 8.13.1.2.1-2 per CC depending on either 2Rx CC or 4Rx CC	≥8
8	10+15+2x20MHz	As specified in Table 8.13.1.2.1-2 per CC depending on either 2Rx CC or 4Rx CC	≥8
9	3x10+20MHz	As specified in Table 8.13.1.2.1-2 per CC depending on either 2Rx CC or 4Rx CC	≥8
10	2x5+2x20MHz	As specified in Table 8.13.1.2.1-2 per CC depending on either 2Rx CC or 4Rx CC	≥8
11	2x5+10+20MHz	As specified in Table 8.13.1.2.1-2 per CC depending on either 2Rx CC or 4Rx CC	≥8
12	4x10MHz	As specified in Table 8.13.1.2.1-2 per CC depending on either 2Rx CC or 4Rx CC	≥8
NOTE 1: The applicability of requirements for different CA configurations and bandwidth combination sets is defined in 8.1.2.6.			

**Table 8.13.1.2.1-6: Minimum performance (FRC) based on single carrier performance for CA with 5 DL CCs**

Test num.	CA Band-width combination	Requirement	UE category
1	5x20MHz	As specified in Table 8.13.1.2.1-2 per CC depending on either 2Rx CC or 4Rx CC	8, ≥11
2	15MHz+4x20MHz	As specified in Table 8.13.1.2.1-2 per CC depending on either 2Rx CC or 4Rx CC	8, ≥11
3	10MHz+4x20MHz	As specified in Table 8.13.1.2.1-2 per CC depending on either 2Rx CC or 4Rx CC	8, ≥11
4	2x10MHz+3x20MHz	As specified in Table 8.13.1.2.1-2 per CC depending on either 2Rx CC or 4Rx CC	8, ≥11
5	5MHz+10MHz+3x20MHz	As specified in Table 8.13.1.2.1-2 per CC depending on either 2Rx CC or 4Rx CC	8, ≥11
6	3x10MHz+2x20MHz	As specified in Table 8.13.1.2.1-2 per CC depending on either 2Rx CC or 4Rx CC	8, ≥11
7	4x10MHz+20MHz	As specified in Table 8.13.1.2.1-2 per CC depending on either 2Rx CC or 4Rx CC	8, ≥11
NOTE 1: The applicability of requirements for different CA configurations and bandwidth combination sets is defined in 8.1.2.6.			

### 8.13.1.3 Enhanced Performance Requirements Type A Closed-loop spatial multiplexing

#### 8.13.1.3.1 Minimum Requirement Single-Layer Spatial Multiplexing 2 Tx Antenna Port with TM4 interference model (Cell-Specific Reference Symbols)

The purpose of these tests is to verify the closed loop rank-one performance with wideband precoding with two transmit antennas when the PDSCH transmission in the serving cell is interfered by PDSCH of one dominant interfering cell

applying transmission mode 4 interference model defined in clause B.5.3. In Table 8.13.1.3.1-1, Cell 1 is the serving cell, and Cell 2 is the interfering cell. The downlink physical channel setup is according to Annex C.3.2 for each of Cell 1 and Cell 2, respectively.

For CA with 2 DL CCs, the requirements are specified in Table 8.13.1.3.1-3, based on single carrier requirement specified in Table 8.13.1.3.1-2, with the addition of the parameters in Table 8.13.1.3.1-1 and the downlink physical channel setup according to Annex C.3.2.

**Table 8.13.1.3.1-1: Test Parameters for Single-Layer Spatial Multiplexing (FRC) with TM4 interference model for CA**

Parameter		Unit	Cell 1	Cell 2
Downlink power allocation	$\rho_A$	dB	-3	-3
	$\rho_B$	dB	-3 (Note 1)	-3
	$\sigma$	dB	0	0
Cell-specific reference signals			Antenna ports 0,1	Antenna ports 0,1
$N_{oc}$ at antenna port		dBm/15kHz	-98	N/A
DIP (Note 2)		dB	N/A	-1.73
Cell Id			0	1
PDSCH transmission mode			6	4
Interference model			N/A	As specified in clause B.5.3
Probability of occurrence of transmission rank in interfering cells	Rank 1	%	N/A	80
	Rank 2	%	N/A	20
Precoding granularity		PRB	25 for 5MHz CCs, 50 for 10MHz CCs, 75 for 15MHz and 100 for 20MHz CCs	4 for 5MHz CCs, 6 for 10MHz CCs, 8 for 15MHz and 20MHz CCs
PMI delay (Note 4)		ms	8	N/A
Reporting interval		ms	5	N/A
Reporting mode			PUCCH 1-1	N/A
CodeBookSubsetRestriction bitmap			1111	N/A
Physical channel for CQI reporting			PUSCH (Note 7)	N/A
cqi-pmi-ConfigurationIndex	FDD PCC		2	N/A
	FDD SCC		3	N/A
Note 1: $P_B = 1$				
Note 2: The respective received power spectral density of each interfering cell relative to $N_{oc}$ is defined by its associated DIP value as specified in clause B.5.1.				
Note 3: Cell 1 is the serving cell. Cell 2 is the interfering cell.				
Note 4: If the UE reports in an available uplink reporting instance at subframe SF#n based on PMI estimation at a downlink SF not later than SF#(n-4), this reported PMI cannot be applied at the eNB downlink before SF#(n+4).				
Note 5: All cells are time-synchronous.				
Note 6: ACK/NACK bits are transmitted using PUSCH with PUCCH format 1b with channel selection configured for tests with 2 CCs.				
Note 7: To avoid collisions between CQI reports and HARQ-ACK it is necessary to report both on PUSCH instead of PUCCH. PDCCH DCI format 0 shall be transmitted in downlink SF#1, SF#2, SF#6 and #7 to allow periodic CQI to multiplex with the HARQ-ACK on PUSCH in uplink subframe SF#5 SF#6 SF#0 and SF#1.				

**Table 8.13.1.3.1-2: Single carrier performance for multiple CA configurations Enhanced Performance Requirement Type A**

Band-width	Reference Channel		OCNG Pattern		Propagation Conditions		Correlation Matrix and Antenna Configuration (Note 3)	Reference Value	
	2Rx CC	4Rx CC	Cell 1	Cell 2	Cell 1	Cell 2			SINR (dB) (Note 2)

							2Rx CC	4Rx CC	Fraction of Maximu m Through put (%)	2Rx CC	4Rx CC
5MHz	R.47-1 FDD	R.47-1 FDD	OP.1 FDD	N/A	EVA5	EVA5	2x2 Low	2x4 Low	70	0.8	-3.0
10 MHz	R.47 FDD	R.47 FDD	OP.1 FDD	N/A	EVA5	EVA5	2x2 Low	2x4 Low	70	1.0	-2.7
15MHz	R.47-2 FDD	R.47-2 FDD	OP.1 FDD	N/A	EVA5	EVA5	2x2 Low	2x4 Low	70	0.8	-2.9
20MHz	R.47-3 FDD	R.47-3 FDD	OP.1 FDD	N/A	EVA5	EVA5	2x2 Low	2x4 Low	70	1.1	-2.8
Note 1: The propagation conditions for Cell 1 and Cell 2 are statistically independent.											
Note 2: SINR corresponds to $E_s/N_{oc}$ of Cell 1 as defined in clause 8.1.1.											
Note 3: Correlation matrix and antenna configuration parameters apply for each of Cell 1 and Cell 2.											

**Table 8.13.1.3.1-3: Minimum performance (FRC) based on single carrier performance for CA with 2 DL CCs**

Test num.	CA Band-width combination	Requirement	UE category
1	2x10 MHz	As specified in Table 8.13.1.3.1-2 per CC depending on either 2Rx CC or 4Rx CC	≥5
2	2x20 MHz	As specified in Table 8.13.1.3.1-2 per CC depending on either 2Rx CC or 4Rx CC	≥5
3	2x5 MHz	As specified in Table 8.13.1.3.1-2 per CC depending on either 2Rx CC or 4Rx CC	≥5
4	15MHz+5MHz	As specified in Table 8.13.1.3.1-2 per CC depending on either 2Rx CC or 4Rx CC	≥5
5	10MHz+5MHz	As specified in Table 8.13.1.3.1-2 per CC depending on either 2Rx CC or 4Rx CC	≥5
Note 1: The applicability of requirements for different CA configurations and bandwidth combination sets is defined in 8.1.2.6.			

#### 8.13.1.4 Enhanced Performance Requirement Type A - Single-layer Spatial Multiplexing (User-Specific Reference Symbols)

##### 8.13.1.4.1 Minimum Requirement Enhanced Performance Requirement Type A – Single-layer Spatial Multiplexing with TM9 interference model (User-Specific Reference Symbols)

The purpose of these tests is to verify closed loop rank one performance on one of the antenna ports 7 or 8 without a simultaneous transmission on the other antenna port in the serving cell when the PDSCH transmission in the serving cell is interfered by PDSCH of one dominant interfering cell applying transmission mode 9 interference model defined in clause B.5.4. In 8.13.1.4.1-1, Cell 1 is the serving cell, and Cell 2 is the interfering cell. The downlink physical channel setup is according to Annex C.3.2 for each of Cell 1 and Cell 2, respectively.

For CA with 2 DL CCs, the requirements are specified in Table 8.13.1.4.1-3, based on single carrier requirement specified in Table 8.13.1.4.1-2, with the addition of the parameters in Table 8.13.1.4.1-1 and the downlink physical channel setup according to Annex C.3.2.

**Table 8.13.1.4.1-1: Test Parameters for Testing CDM-multiplexed DM RS (single layer) with TM9 interference model for CA**

parameter		Unit	Cell 1	Cell 2
Downlink power allocation	$\rho_A$	dB	0	0
	$\rho_B$	dB	0 (Note 1)	0
	$\sigma$	dB	-3	-3

Cell-specific reference signals		Antenna ports 0,1	Antenna ports 0,1
CSI reference signals		Antenna ports 15,16	N/A
CSI-RS periodicity and subframe offset $T_{\text{CSI-RS}} / \Delta_{\text{CSI-RS}}$	Subframes	5 / 2	N/A
CSI reference signal configuration		0	N/A
$N_{oc}$ at antenna port	dBm/15kHz	-98	N/A
DIP (Note 2)	dB	N/A	-1.73
$BW_{\text{Channel}}$	MHz	10	10
Cell Id		0	126
PDSCH transmission mode		9	9
Beamforming model		As specified in clause B.4.3 (Note 4, 5)	N/A
Interference model		N/A	As specified in clause B.5.4
Probability of occurrence of transmission rank in interfering cells	Rank 1	N/A	70
	Rank 2	N/A	30



Precoder update granularity	PRB	25 for 5MHz CCs, 50 for 10MHz CCs, 75 for 15MHz and 100 for 20MHz CCs	4 for 5MHz CCs, 6 for 10MHz CCs, 8 for 15MHz and 20MHz CCs
PMI delay (Note 5)	Ms	8	N/A
Reporting interval	Ms	5	N/A
Reporting mode		PUCCH 1-1	N/A
CodeBookSubsetRestriction bitmap		001111	N/A
Symbols for unused PRBs		OCNG (Note 6)	N/A
Simultaneous transmission		No simultaneous transmission on the other antenna port in (7 or 8) used for the input signal under test	N/A
Physical channel for CQI reporting		PUSCH(Note 8)	N/A
cqj-pmi-ConfigurationIndex	FDD PCC	4	N/A
	FDD SCC	5	N/A
<p>Note 1: <math>P_B = 1</math></p> <p>Note 2: The respective received power spectral density of each interfering cell relative to <math>N_{oc}</math> is defined by its associated DIP value as specified in clause B.5.1.</p> <p>Note 3: The modulation symbols of the signal under test in Cell 1 are mapped onto antenna port 7 or 8.</p> <p>Note 4: The precoder in clause B.4.3 follows UE recommended PMI.</p> <p>Note 5: If the UE reports in an available uplink reporting instance at subframe SF#n based on PMI estimation at a downlink SF not later than SF#(n-4), this reported PMI cannot be applied at the eNB downlink before SF#(n+4).</p> <p>Note 6: These physical resource blocks are assigned to an arbitrary number of virtual UEs with one PDSCH per virtual UE; the data transmitted over the OCNG PDSCHs shall be uncorrelated pseudo random data, which is QPSK modulated.</p> <p>Note 7: All cells are time-synchronous.</p> <p>Note 8: To avoid collisions between CQI reports and HARQ-ACK it is necessary to report both on PUSCH instead of PUCCH. PDCCCH DCI format 0 shall be transmitted in downlink SF#3, SF#4, SF#8 and #9 to allow periodic CQI to multiplex with the HARQ-ACK on PUSCH in uplink subframe SF#7, SF#8, SF#2 and #3.</p> <p>Note 9: ACK/NACK bits are transmitted using PUSCH with PUCCH format 1b with channel selection configured for tests with 2 CCs.</p>			

**Table 8.13.1.4.1-2: Single carrier performance for multiple CA configurations Enhanced Performance Requirement Type A, CDM-multiplexed DM RS**

Bandwidth	Reference Channel		OCNG Pattern		Propagation Conditions		Correlation Matrix and Antenna Configuration (Note 3)		Reference Value		
	2Rx CC	4Rx CC	Cell 1	Cell 2	Cell 1	Cell 2	2Rx CC	4Rx CC	Fraction of Maximum Throughput (%)	SINR (dB) (Note 2)	
										2Rx CC	4Rx CC

5MHz	R.76-1 FDD	R.76-4 FDD	OP.1 FDD	N/A	EVA5	EVA5	2x2 Low	2x4 Low	70	-0.4	-2.0
10 MHz	R.76 FDD	R.76-5 FDD	OP.1 FDD	N/A	EVA5	EVA5	2x2 Low	2x4 Low	70	0.1	-1.8
15MHz	R.76-2 FDD	R.76-6 FDD	OP.1 FDD	N/A	EVA5	EVA5	2x2 Low	2x4 Low	70	-0.2	-1.9
20MHz	R.76-3 FDD	R.76-7 FDD	OP.1 FDD	N/A	EVA5	EVA5	2x2 Low	2x4 Low	70	-0.4	-1.7

Note 1: The propagation conditions for Cell 1 and Cell 2 are statistically independent.

Note 2: SINR corresponds to  $E_s/N_{oc}$  of Cell 1 as defined in clause 8.1.1.

Note 3: Correlation matrix and antenna configuration parameters apply for each of Cell 1 and Cell 2.

**Table 8.13.1.4.1-3: Minimum performance (FRC) based on single carrier performance for CA with 2 DL CCs**

Test num.	CA Band-width combination	Requirement	UE category
1	2x10 MHz	As specified in Table 8.13.1.4.1-2 per CC depending on either 2Rx CC or 4Rx CC	≥5
2	2x20 MHz	As specified in Table 8.13.1.4.1-2 per CC depending on either 2Rx CC or 4Rx CC	≥5
3	2x5 MHz	As specified in Table 8.13.1.4.1-2 per CC depending on either 2Rx CC or 4Rx CC	≥5
4	15MHz+5MHz	As specified in Table 8.13.1.4.1-2 per CC depending on either 2Rx CC or 4Rx CC	≥5
5	10MHz+5MHz	As specified in Table 8.13.1.4.1-2 per CC depending on either 2Rx CC or 4Rx CC	≥5

Note 1: The applicability of requirements for different CA configurations and bandwidth combination sets is defined in 8.1.2.6.

## 8.13.2 TDD (CA and DC)

The parameters specified in Table 8.13.2-1 are valid for all TDD CA and DC tests unless otherwise stated.

**Table 8.13.2-1: Common Test Parameters (TDD)**

Parameter	Unit	Value
Uplink downlink configuration (Note 1)		1
Special subframe configuration (Note 2)		4
Cyclic prefix		Normal
Cell ID		0
Inter-TTI Distance		1
Number of HARQ processes per component carrier	Processes	7
Maximum number of HARQ transmission		4
Redundancy version coding sequence		{0,1,2,3} for QPSK and 16QAM {0,0,1,2} for 64QAM and 256QAM
Number of OFDM symbols for PDCCH per component carrier	OFDM symbols	4 for 1.4 MHz bandwidth, 3 for 3 MHz and 5 MHz bandwidths, 2 for 10 MHz, 15 MHz and 20 MHz bandwidths unless otherwise stated
Cross carrier scheduling		Not configured

Note 1: as specified in Table 4.2-2 in TS 36.211 [4].

Note 2: as specified in Table 4.2-1 in TS 36.211 [4].

## 8.13.2.1 Closed-loop spatial multiplexing performance

### 8.13.2.1.1 Minimum Requirement Multi-Layer Spatial Multiplexing 4 Tx Antenna Port

For CA with 2 DL CCs, the requirements are specified in Table 8.13.2.1.1-2A, based on single carrier requirement specified in Table 8.13.2.1.1-2, with the addition of the parameters in Table 8.13.2.1.1-1 and the downlink physical channel setup according to Annex C.3.2.

For CA with 3 DL CCs, the requirements are specified in Table 8.13.2.1.1-3, based on single carrier requirement specified in Table 8.13.2.1.1-2, with the addition of the parameters in Table 8.13.2.1.1-1 and the downlink physical channel setup according to Annex C.3.2.

For CA with 4 DL CCs, the requirements are specified in Table 8.13.2.1.1-4, based on single carrier requirement specified in Table 8.13.2.1.1-2, with the addition of the parameters in Table 8.13.2.1.1-1 and the downlink physical channel setup according to Annex C.3.2.

For CA with 5 DL CCs, the requirements are specified in Table 8.13.2.1.1-5, based on single carrier requirement specified in Table 8.13.2.1.1-2, with the addition of the parameters in Table 8.13.2.1.1-1 and the downlink physical channel setup according to Annex C.3.2.

The test coverage for different number of component carriers is defined in 8.1.2.4.

**Table 8.13.2.1.1-1: Test Parameters for Multi-Layer Spatial Multiplexing (FRC) for CA**

Parameter	Unit	Value	
Downlink power allocation	$\rho_A$	dB	-6
	$\rho_B$	dB	-6 (Note 1)
	$\sigma$	dB	3
$N_{oc}$ at antenna port	dBm/15kHz	-98	
Precoding granularity	PRB	8	
PMI delay (Note 2)	ms	10 or 11	
Reporting interval	ms	1 or 4 (Note 3)	
Reporting mode		PUSCH 1-2	
ACK/NACK feedback mode		PUCCH format 1b with channel selection for Tests with 2CCs; PUCCH format 3 for Tests with more than 2 CCs	
CodeBookSubsetRestriction bitmap		000000000000000000000000000000 0000111111111111111110000000 00000000	
CSI request field (Note 4)		'10'	
PDSCH transmission mode		4	
Note 1: $\rho_B = 1$ .			
Note 2: If the UE reports in an available uplink reporting instance at subframe SF#n based on PMI estimation at a downlink SF not later than SF#(n-4), this reported PMI cannot be applied at the eNB downlink before SF#(n+4)			
Note 3: For Uplink - downlink configuration 1 the reporting interval will alternate between 1ms and 4ms.			
Note 4: Multiple CC-s under test are configured as the 1 <sup>st</sup> set of serving cells by high layers.			
Note 5: The same PDSCH transmission mode is applied to each component carrier.			

Table 8.13.2.1.1-2: Single carrier performance for multiple CA configurations

Band - width	Reference channel		OCNG pattern	Propagation condition	Correlation matrix and antenna config.		Reference value		
							Fraction of maximum throughput (%)	SNR (dB)	
	2Rx CC	4Rx CC			2Rx CC	4Rx CC			
1.4M Hz	R.43-1 TDD	R.43-1 TDD	OP.1 TDD	EVA5	4x2 Low	4x4 Low	70	11.0	8.1
3MHz	R.43-2 TDD	R.43-2 TDD	OP.1 TDD	EVA5	4x2 Low	4x4 Low	70	9.8	5.4
5MHz	R.43-3 TDD	R.43-3 TDD	OP.1 TDD	EVA5	4x2 Low	4x4 Low	70	10.0	5.9
10 MHz	R.43-4 TDD	R.43-4 TDD	OP.1 TDD	EVA5	4x2 Low	4x4 Low	70	10.5	6.3
15M Hz	R.43-5 TDD	R.43-5 TDD	OP.1 TDD	EVA5	4x2 Low	4x4 Low	70	10.6	6.2
20M Hz	R.43 TDD	R.43 TDD	OP.1 TDD	EVA5	4x2 Low	4x4 Low	70	10.7	6.4

Table 8.13.2.1.1-2A: Minimum performance (FRC) based on single carrier performance for CA with 2 DL CCs

Test num.	CA Band-width combination	Requirement	UE category
1	2x20MHz	As specified in Table 8.13.2.1.1-2 per CC depending on either 2Rx CC or 4Rx CC	≥5
2	20MHz+15MHz	As specified in Table 8.13.2.1.1-2 per CC depending on either 2Rx CC or 4Rx CC	≥5
Note 1: The applicability of requirements for different CA configurations and bandwidth combination sets is defined in 8.1.2.6.			

Table 8.13.2.1.1-3: Minimum performance (FRC) based on single carrier performance for CA with 3 DL CCs

Test num.	CA Band-width combination	Requirement	UE category
1	3x20MHz	As specified in Table 8.13.2.1.1-2 per CC depending on either 2Rx CC or 4Rx CC	≥5
2	20MHz+20MHz+15MHz	As specified in Table 8.13.2.1.1-2 per CC depending on either 2Rx CC or 4Rx CC	≥5
Note 1: The applicability of requirements for different CA configurations and bandwidth combination sets is defined in 8.1.2.6.			

Table 8.13.2.1.1-4: Minimum performance (FRC) based on single carrier performance for CA with 4 DL CCs

Test num.	CA Band-width combination	Requirement	UE category
1	4x20MHz	As specified in Table 8.13.2.1.1-2 per CC depending on either 2Rx CC or 4Rx CC	≥8
2	20MHz+20MHz+20MHz+15MHz	As specified in Table 8.13.2.1.1-2 per CC depending on either 2Rx CC or 4Rx CC	≥8
Note 1: The applicability of requirements for different CA configurations and bandwidth combination sets is defined in 8.1.2.6.			

Table 8.13.2.1.1-5: Minimum performance (FRC) based on single carrier performance for CA with 5 DL CCs

Test num.	CA Band-width combination	Requirement	UE category

1	5x20MHz	As specified in Table 8.13.2.1.1-2 per CC depending on either 2Rx CC or 4Rx CC	8, $\geq 11$
2	15MHz+4x20MHz	As specified in Table 8.13.2.1.1-2 per CC depending on either 2Rx CC or 4Rx CC	8, $\geq 11$
Note 1: The applicability of requirements for different CA configurations and bandwidth combination sets is defined in 8.1.2.6			

### 8.13.2.1.2 Minimum Requirement Multi-Layer Spatial Multiplexing 4 Tx Antenna Port for dual connectivity

For dual connectivity the requirements are specified in Table 8.13.2.1.2-3, for 2DL CCs, in Table 8.13.2.1.2-4 for 3DL CCs, and Table 8.13.2.1.2-5 for 4DL CCs, based on single carrier requirement specified in Table 8.13.2.1.2-2, with the addition of the parameters in Table 8.13.2.1.2-1 and the downlink physical channel setup according to Annex C.3.2. The purpose of these tests is to verify the closed loop rank-two performance with wideband and frequency selective precoding by using dual connectivity.

**Table 8.13.2.1.2-1: Test Parameters for Multi-Layer Spatial Multiplexing (FRC) for dual connectivity**

Parameter	Unit	Value	
Downlink power allocation	$\rho_A$	dB	-6
	$\rho_B$	dB	-6 (Note 1)
	$\sigma$	dB	3
$N_{oc}$ at antenna port	dBm/15kHz	-98	
Precoding granularity	PRB	6 for 1.4MHz, 4 for 3MHz and 5MHz CCs, 6 for 10MHz CCs, and 8 for 15MHz CCs and 20MHz CCs	
PMI delay (Note 2)	ms	10 or 11	
Reporting interval	ms	1 or 4 (Note 3)	
Reporting mode		PUSCH 1-2	
CodeBookSubsetRestriction bitmap		000000000000000000000000000000 00001111111111111111111110000000 00000000	
PDSCH transmission mode		4	
ACK/NACK transmission		Separate ACK/NACK feedbacks with PUCCH format 1b on the MCG and SCG	
CSI feedback		Separate PUSCH feedbacks on the MCG and SCG	
Time offset between MCG CC and SCG CC	$\mu$ s	0 for UE under test supporting synchronous dual connectivity; 334 for UE under test supporting both asynchronous and synchronous dual connectivity (Note 5)	
Note 1: $P_B = 1$ .			
Note 2: If the UE reports in an available uplink reporting instance at subframe SF#n based on PMI estimation at a downlink SF not later than SF#(n-4), this reported PMI cannot be applied at the eNB downlink before SF#(n+4)			
Note 3: For Uplink - downlink configuration 1 the reporting interval will alternate between 1ms and 4ms.			
Note 4: The same PDSCH transmission mode is applied to each component carrier.			
Note 5: As defined in TS36.300 [11].			
Note 6: If the UE supports both SCG bearer and Split bearer, the SCG bearer is configured.			

**Table 8.13.2.1.1-2: Single carrier performance for multiple DC configurations**

Band - width	Reference channel		OCNG pattern	Propagation condition	Correlation matrix and antenna config.		Reference value	
	2Rx CC	4Rx CC			2Rx CC	4Rx CC	Fraction of maximum throughput (%)	SNR (dB)
							2Rx CC	4Rx CC

1.4M Hz	R.43-1 TDD	R.43-1 TDD	OP.1 TDD	EVA5	4x2 Low	4x4 Low	70	11.0	8.1
3MHz	R.43-2 TDD	R.43-2 TDD	OP.1 TDD	EVA5	4x2 Low	4x4 Low	70	9.8	5.4
5MHz	R.43-3 TDD	R.43-3 TDD	OP.1 TDD	EVA5	4x2 Low	4x4 Low	70	10.0	5.9
10 MHz	R.43-4 TDD	R.43-4 TDD	OP.1 TDD	EVA5	4x2 Low	4x4 Low	70	10.5	6.3
15M Hz	R.43-5 TDD	R.43-5 TDD	OP.1 TDD	EVA5	4x2 Low	4x4 Low	70	10.6	6.2
20M Hz	R.43 TDD	R.43 TDD	OP.1 TDD	EVA5	4x2 Low	4x4 Low	70	10.7	6.4

**Table 8.13.2.1.2-3: Minimum performance Multi-Layer Spatial Multiplexing (FRC) for dual connectivity**

Test num.	Band-width combination	Requirement	UE category
1	2x20 MHz	As specified in Table 8.13.2.1.2-2 per CC depending on either 2Rx CC or 4Rx CC	≥5
Note 1: The OCNG pattern applies for each CC. Note 2: The applicability of requirements for different dual connectivity configurations and bandwidth combination sets is defined in 8.1.2.6.			

**Table 8.13.2.1.2-4: Minimum performance Multi-Layer Spatial Multiplexing (FRC) for dual connectivity**

Test num.	Band-width combination	Requirement	UE category
1	3x20 MHz	As specified in Table 8.13.2.1.2-2 per CC depending on either 2Rx CC or 4Rx CC	≥5
Note 1: The OCNG pattern applies for each CC. Note 2: The applicability of requirements for different dual connectivity configurations and bandwidth combination sets is defined in 8.1.2.6.			

**Table 8.13.2.1.2-5: Minimum performance Multi-Layer Spatial Multiplexing (FRC) for dual connectivity**

Test num.	Band-width combination	Requirement	UE category
1	4x20 MHz	As specified in Table 8.13.2.1.2-2 per CC depending on either 2Rx CC or 4Rx CC	≥8
2	15+20+20+20MHz	As specified in Table 8.13.2.1.2-2 per CC depending on either 2Rx CC or 4Rx CC	≥8
Note 1: The OCNG pattern applies for each CC. Note 2: The applicability of requirements for different dual connectivity configurations and bandwidth combination sets is defined in 8.1.2.6.			

### 8.13.2.1.3 Minimum Requirement Multi-Layer Spatial Multiplexing 4 Tx Antenna Port with 256QAM

The purpose of these tests is to verify the closed loop rank-two performance with frequency selective precoding with 256QAM under CA.

For CA with 2 DL CCs, the requirements are specified in Table 8.13.2.1.3-3, based on single carrier requirement specified in Table 8.13.2.1.3-2, with the addition of the parameters in Table 8.13.2.1.3-1 and the downlink physical channel setup according to Annex C.3.2. The test coverage for different number of component carriers is defined in 8.1.2.4.

**Table 8.13.2.1.3-1: Test Parameters for Multi-Layer Spatial Multiplexing (FRC) for CA**

Parameter	Unit	Value
Downlink power allocation	$\rho_A$	dB
	$\rho_B$	dB
	$\sigma$	dB
$N_{oc}$ at antenna port	dBm/15kHz	-98
Precoding granularity	PRB	4 for 3MHz and 5MHz CCs, 6 for 10MHz CCs, 8 for 15MHz and 20MHz CCs
PMI delay (Note 2)	ms	10 or 11
Reporting interval	ms	1 or 4 (Note 3)
Reporting mode		PUSCH 1-2
ACK/NACK feedback mode		PUCCH format 1b with channel selection for Tests with 2CCs
CodeBookSubsetRestriction bitmap		00000000000000000000000000000000 0000111111111111111111111100000000 00000000
CSI request field (Note 4)		'10'
PDSCH transmission mode		4
Note 1: $P_B = 1$ .		
Note 2: If the UE reports in an available uplink reporting instance at subframe SF#n based on PMI estimation at a downlink SF not later than SF#(n-4), this reported PMI cannot be applied at the eNB downlink before SF#(n+4)		
Note 3: For Uplink - downlink configuration 1 the reporting interval will alternate between 1ms and 4ms.		
Note 4: Multiple CC-s under test are configured as the 1 <sup>st</sup> set of serving cells by high layers.		
Note 5: The same PDSCH transmission mode is applied to each component carrier.		

**Table 8.13.2.1.3-2: Single carrier performance for multiple CA configurations**

Band - width	Reference channel		OCNG pattern	Propagation condition	Correlation matrix and antenna config.		Reference value		
							Fraction of maximum throughput (%)	SNR (dB)	
	2Rx CC	4Rx CC			2Rx CC	4Rx CC			
5MHz	R.72-1 TDD	R.72-1 TDD	OP.1 TDD	EPA5	4x2 Low	4x4 Low	70	22.4	18.0
10 MHz	R.72 TDD	R.72 TDD	OP.1 TDD	EPA5	4x2 Low	4x4 Low	70	21.4	17.5
15M Hz	R.72-2 TDD	R.72-2 TDD	OP.1 TDD	EPA5	4x2 Low	4x4 Low	70	21.5	17.1
20M Hz	R.72-3 TDD	R.72-3 TDD	OP.1 TDD	EPA5	4x2 Low	4x4 Low	70	21.6	17.2

**Table 8.13.2.1.3-3: Minimum performance (FRC) based on single carrier performance for CA with 2 DL CCs**

Test num.	CA Band-width combination	Requirement	UE category
1	2x20MHz	As specified in Table 8.13.2.1.3-2 per CC depending on either 2Rx CC or 4Rx CC	$\geq 5$
2	20MHz+15MHz	As specified in Table 8.13.2.1.3-2 per CC depending on either 2Rx CC or 4Rx CC	$\geq 5$
Note 1: The applicability of requirements for different CA configurations and bandwidth combination sets is defined in 8.1.2.6.			

#### 8.13.2.1.4 Minimum Requirement Four-Layer Spatial Multiplexing 4 Tx Antenna Port

The purpose of these tests is to verify the closed loop rank-four performance with wideband precoding with 4Tx and 4Rx under CA.

For CA with 2 DL CCs, the requirements are specified in Table 8.13.2.1.4-3, based on single carrier requirement specified in Table 8.13.2.1.4-2, with the addition of the parameters in Table 8.13.2.1.4-1 and the downlink physical channel setup according to Annex C.3.2. The test coverage for different number of component carriers is defined in 8.1.2.4.

**Table 8.13.2.1.4-1: Test Parameters for Multi-Layer Spatial Multiplexing (FRC) for CA**

Parameter	Unit	Value
Downlink power allocation	$\rho_A$	dB
	$\rho_B$	dB
	$\sigma$	dB
$N_{oc}$ at antenna port	dBm/15kHz	-98
Cell-specific reference signals		Antenna ports 0,1,2,3
PDSCH transmission mode		4
PDSCH rank		4
Precoding granularity	PRB	25 for 5MHz CCs, 50 for 10MHz CCs, 75 for 15MHz and 100 for 20MHz CCs
PMI delay	ms	10 or 11
Reporting interval	ms	1 or 4
Reporting mode		PUSCH 3-1
CodeBookSubsetRestriction bitmap		0xFFFF000000000000
ACK/NACK feedback mode		PUCCH format 1b with channel selection for Tests with 2CCs
CSI request field (Note 4)		'10'
PDSCH transmission mode		4
Uplink-Downlink Configuration		1
Special subframe configuration		4
Note 1: $P_B = 1$ .		
Note 2: If the UE reports in an available uplink reporting instance at subframe SF#n based on PMI estimation at a downlink SF not later than SF#(n-4), this reported PMI cannot be applied at the eNB downlink before SF#(n+4)		
Note 3: For Uplink - downlink configuration 1 the reporting interval will alternate between 1ms and 4ms.		
Note 4: Multiple CC-s under test are configured as the 1 <sup>st</sup> set of serving cells by high layers.		
Note 5: The same PDSCH transmission mode is applied to each component carrier.		

**Table 8.13.2.1.4-2: Single carrier performance for multiple CA configurations**

Band-width	Reference channel	OCNG pattern	Propagation condition	Correlation matrix and antenna config	Reference value	
					Fraction of maximum throughput (%)	SNR (dB)
5MHz	R.74-1 TDD	OP.1 TDD	EPA5	4x4 Low	70	14.5
10MHz	R.74 TDD	OP.1 TDD	EPA5	4x4 Low	70	14.4
15MHz	R.74-2 TDD	OP.1 TDD	EPA5	4x4 Low	70	14.6
20MHz	R.74-3 TDD	OP.1 TDD	EPA5	4x4 Low	70	14.8

**Table 8.13.2.1.4-3: Minimum performance (FRC) based on single carrier performance for CA with 2 DL CCs**

Test num.	CA Band-width combination	Requirement	UE category
1	2x20MHz	As specified in Table 8.13.2.1.4-2 per CC	$\geq 5$
2	20MHz+15MHz	As specified in Table 8.13.2.1.4-2 per CC	$\geq 5$
Note 1: The applicability of requirements for different CA configurations and bandwidth combination sets is defined in 8.1.2.6.			



## 8.13.2.2 Dual-Layer Spatial Multiplexing (User-Specific Reference Symbols)

### 8.13.2.2.1 Minimum Requirement Dual-Layer Spatial Multiplexing 2 Tx Antenna Port

For CA with 2 DL CCs, for dual-layer transmission on antenna ports 7 and 8 upon detection of a PDCCH with DCI format 2C, the requirements are specified in Table 8.13.2.2.1-2A, based on single carrier requirement specified in Table 8.13.2.2.1-2, with the addition of the parameters in Table 8.13.2.2.1-1 and the downlink physical channel setup according to Annex C.3.2.

For CA with 3 DL CCs, for dual-layer transmission on antenna ports 7 and 8 upon detection of a PDCCH with DCI format 2C, the requirements are specified in Table 8.13.2.2.1-3, based on single carrier requirement specified in Table 8.13.2.2.1-2, with the addition of the parameters in Table 8.13.2.2.1-1 and the downlink physical channel setup according to Annex C.3.2.

For CA with 4 DL CCs, for dual-layer transmission on antenna ports 7 and 8 upon detection of a PDCCH with DCI format 2C, the requirements are specified in Table 8.13.2.2.1-4, based on single carrier requirement specified in Table 8.13.2.2.1-2, with the addition of the parameters in Table 8.13.2.2.1-1 and the downlink physical channel setup according to Annex C.3.2.

For CA with 5 DL CCs, for dual-layer transmission on antenna ports 7 and 8 upon detection of a PDCCH with DCI format 2C, the requirements are specified in Table 8.13.2.2.1-5, based on single carrier requirement specified in Table 8.13.2.2.1-2, with the addition of the parameters in Table 8.13.2.2.1-1 and the downlink physical channel setup according to Annex C.3.2.

The test coverage for different number of component carriers is defined in 8.1.2.4.

**Table 8.13.2.2.1-1: Test Parameters for Multi-Layer Spatial Multiplexing (FRC) for CA**

Parameter	Unit	Values	
Downlink power allocation	$\rho_A$	dB	0
	$\rho_B$	dB	0 (Note 1)
	$\sigma$	dB	-3
Cell-specific reference signals		Antenna ports 0 and 1	
Cell ID		0	
CSI reference signals		Antenna ports 15,16	
Beamforming model		Annex B.4.2	
CSI-RS periodicity and subframe offset $T_{\text{CSI-RS}} / \Delta_{\text{CSI-RS}}$	Subframes	5 / 4	
CSI reference signal configuration		8	
Zero-power CSI-RS configuration $I_{\text{CSI-RS}} / \text{ZeroPowerCSI-RS}$ bitmap	Subframes / bitmap	4 / 0010000000000000	
$N_{oc}$ at antenna port	dBm/15kHz	-98	
$E_s / N_{oc}$		Reference Value in Table 8.13.2.2.1-2	
Symbols for unused PRBs		OCNG (Note 2)	
Number of allocated resource blocks (Note 2)	PRB	50	
Simultaneous transmission		No	
PDSCH transmission mode		9	
Note 1: $P_B = 1$			
Note 2: These physical resource blocks are assigned to an arbitrary number of virtual UEs with one PDSCH per virtual UE; the data transmitted over the OCNG PDSCHs shall be uncorrelated pseudo random data, which is QPSK modulated.			

Table 8.13.2.2.1-2: Single carrier performance for multiple CA configurations

Band - width	Reference channel		OCNG pattern	Propa- gation condi- tion	Correlation matrix and antenna config.		Reference value		
							Fraction of maximum throughpu t (%)	SNR (dB)	
	2Rx CC	4Rx CC			2Rx CC	4Rx CC			
5MHz	R.51-2 TDD	R.51-2 TDD	OP.1 TDD	ETU5	2x2 Low	2x4 Low	70	14.0	9.0
10 MHz	R.51 TDD	R.51 TDD	OP.1 TDD	ETU5	2x2 Low	2x4 Low	70	13.9	9.1
15M Hz	R.51-3 TDD	R.51-3 TDD	OP.1 TDD	ETU5	2x2 Low	2x4 Low	70	13.9	9.2
20M Hz	R.51-4 TDD	R.51-4 TDD	OP.1 TDD	ETU5	2x2 Low	2x4 Low	70	14.1	9.3

Note 1: The propagation conditions for Cell 1 and Cell 2 are statistically independent.  
Note 2: Correlation matrix and antenna configuration parameters apply for each of Cell 1 and Cell 2.  
Note 3: SNR corresponds to  $\hat{E}_s/N_{oc}$  of Cell 1.

Table 8.13.2.2.1-2A: Minimum performance (FRC) based on single carrier performance for CA with 2 DL CCs

Test num.	CA Band-width combination	Requirement	UE category
1	2x20MHz	As specified in Table 8.13.2.2.1-2 per CC depending on either 2Rx CC or 4Rx CC	≥5
2	20MHz+15MHz	As specified in Table 8.13.2.2.1-2 per CC depending on either 2Rx CC or 4Rx CC	≥5

Note 1: The applicability of requirements for different CA configurations and bandwidth combination sets is defined in 8.1.2.6.

Table 8.13.2.2.1-3: Minimum performance (FRC) based on single carrier performance for CA with 3 DL CCs

Test num.	CA Band-width combination	Requirement	UE category
1	3x20MHz	As specified in Table 8.13.2.2.1-2 per CC depending on either 2Rx CC or 4Rx CC	≥5
2	20MHz+20MHz+15MHz	As specified in Table 8.13.2.2.1-2 per CC depending on either 2Rx CC or 4Rx CC	≥5

Note 1: The applicability of requirements for different CA configurations and bandwidth combination sets is defined in 8.1.2.6.

Table 8.13.2.2.1-4: Minimum performance (FRC) based on single carrier performance for CA with 4 DL CCs

Test num.	CA Band-width combination	Requirement	UE category
1	4x20MHz	As specified in Table 8.13.2.2.1-2 per CC depending on either 2Rx CC or 4Rx CC	≥8
2	20MHz+20MHz+20MHz+15MHz	As specified in Table 8.13.2.2.1-2 per CC depending on either 2Rx CC or 4Rx CC	≥8

Note 1: The applicability of requirements for different CA configurations and bandwidth combination sets is defined in 8.1.2.6.

Table 8.13.2.1.1-5: Minimum performance (FRC) based on single carrier performance for CA with 5 DL CCs

Test num.	CA Band-width combination	Requirement	UE category
-----------	---------------------------	-------------	-------------

1	5x20MHz	As specified in Table 8.13.2.2.1-2 per CC depending on either 2Rx CC or 4Rx CC	8, $\geq 11$
2	15MHz+4x20MHz	As specified in Table 8.13.2.2.1-2 per CC depending on either 2Rx CC or 4Rx CC	8, $\geq 11$
Note 1: The applicability of requirements for different CA configurations and bandwidth combination sets is defined in 8.1.2.6			

### 8.13.2.3 Enhanced Performance Requirements Type A Closed-loop spatial multiplexing

#### 8.13.2.3.1 Minimum Requirement Single-Layer Spatial Multiplexing 2 Tx Antenna Port with TM4 interference model (Cell-Specific Reference Symbols)

The purpose of these tests is to verify the closed loop rank-one performance with wideband precoding with two transmit antennas when the PDSCH transmission in the serving cell is interfered by PDSCH of one dominant interfering cell applying transmission mode 4 interference model defined in clause B.5.3. In Table 8.13.2.3.1-1, Cell 1 is the serving cell, and Cell 2 is the interfering cell. The downlink physical channel setup is according to Annex C.3.2 for each of Cell 1 and Cell 2, respectively.

For CA with 2 DL CCs, the requirements are specified in Table 8.13.2.3.1-3, based on single carrier requirement specified in Table 8.13.2.3.1-2, with the addition of the parameters in Table 8.13.2.3.1-1 and the downlink physical channel setup according to Annex C.3.2.

**Table 8.13.2.3.1-1: Test Parameters for Single-Layer Spatial Multiplexing (FRC) with TM4 interference model for CA**

Parameter		Unit	Cell 1	Cell 2
Downlink power allocation	$\rho_A$	dB	-3	-3
	$\rho_B$	dB	-3 (Note 1)	-3
	$\sigma$	dB	0	0
Cell-specific reference signals			Antenna ports 0,1	Antenna ports 0,1
$N_{oc}$ at antenna port		dBm/15kHz	-98	N/A
DIP (Note 2)		dB	N/A	-1.73
BW <sub>Channel</sub>		MHz	10	10
Cell Id			0	1
PDSCH transmission mode			6	N/A
Interference model			N/A	As specified in clause B.5.3
Probability of occurrence of transmission rank in interfering cells	Rank 1	%	N/A	80
	Rank 2	%	N/A	20

Precoding granularity	PRB	50	6
PMI delay (Note 4)	ms	10 or 11	N/A
Reporting interval	ms	5	N/A
Reporting mode		PUCCH 1-1	N/A
CodeBookSubsetRestriction bitmap		1111	N/A
Physical channel for CQI reporting		PUSCH (Note 7)	N/A
cqi-pmi-ConfigurationIndex	TDD PCC	3	N/A
	TDD SCC	4	N/A

Note 1:  $P_B = 1$

Note 2: The respective received power spectral density of each interfering cell relative to  $N_{oc}$  is defined by its associated DIP value as specified in clause B.5.1.

Note 3: Cell 1 is the serving cell. Cell 2, 3 are the interfering cells.

Note 4: If the UE reports in an available uplink reporting instance at subframe SF#n based on PMI estimation at a downlink SF not later than SF#(n-4), this reported PMI cannot be applied at the eNB downlink before SF#(n+4).

Note 5: All cells are time-synchronous.

Note 6: ACK/NACK bits are transmitted using PUSCH with PUCCH format 1b with channel selection configured for tests with 2 CCs.

Note 7: To avoid collisions between CQI reports and HARQ-ACK it is necessary to report both on PUSCH instead of PUCCH. PDCCH DCI format 0 shall be transmitted in downlink SF#1, SF#4, SF#6 and #9 to allow periodic CQI to multiplex with the HARQ-ACK on PUSCH in uplink subframe SF#7 SF#8 SF#2 and SF#3.

**Table 8.13.2.3.1-2: Single carrier performance for multiple CA configurations Enhanced Performance Requirement Type A**

Bandwidth	Reference Channel		OCNG Pattern		Propagation Conditions		Correlation Matrix and Antenna Configuration (Note 3)		Reference Value		
	2Rx CC	4Rx CC	Cell 1	Cell 2	Cell 1	Cell 2	2Rx CC	4Rx CC	Fraction of Maximum Throughput (%)	SINR (dB) (Note 2)	
										2Rx CC	4Rx CC
5MHz	R.47-1 TDD	R.47-1 TDD	OP.1 TDD	N/A	EVA5	EVA5	2x2 Low	2x4 Low	70	0.8	-2.8
10 MHz	R.47 TDD	R.47 TDD	OP.1 TDD	N/A	EVA5	EVA5	2x2 Low	2x4 Low	70	1.3	-2.5
15MHz	R.47-2 TDD	R.47-2 TDD	OP.1 TDD	N/A	EVA5	EVA5	2x2 Low	2x4 Low	70	1.0	-2.7
20MHz	R.47-3 TDD	R.47-3 TDD	OP.1 TDD	N/A	EVA5	EVA5	2x2 Low	2x4 Low	70	1.3	-2.3

Note 1: The propagation conditions for Cell 1 and Cell 2 are statistically independent.

Note 2: SINR corresponds to  $E_s/N_{oc}$  of Cell 1 as defined in clause 8.1.1.

Note 3: Correlation matrix and antenna configuration parameters apply for each of Cell 1 and Cell 2.

**Table 8.13.2.3.1-3: Minimum performance (FRC) based on single carrier performance for CA with 2 DL CCs**

Test num.	CA Band-width combination	Requirement	UE category
1	2x20MHz	As specified in Table 8.13.2.3.1-2 per CC depending on either 2Rx CC or 4Rx CC	≥5
2	20MHz+15MHz	As specified in Table 8.13.2.3.1-2 per CC depending on either 2Rx CC or 4Rx CC	≥5

Note 1: The applicability of requirements for different CA configurations and bandwidth combination sets is defined in 8.1.2.6.

### 8.13.2.4 Enhanced Performance Requirement Type A - Single-layer Spatial Multiplexing (User-Specific Reference Symbols)

#### 8.13.2.4.1 Minimum Requirement Enhanced Performance Requirement Type A – Single-layer Spatial Multiplexing with TM9 interference model (User-Specific Reference Symbols)

The purpose of these tests is to verify closed loop rank one performance on one of the antenna ports 7 or 8 without a simultaneous transmission on the other antenna port in the serving cell when the PDSCH transmission in the serving cell is interfered by PDSCH of one dominant interfering cell applying transmission mode 9 interference model defined in clause B.5.4. In 8.13.2.4.1-1, Cell 1 is the serving cell, and Cell 2 is the interfering cell. The downlink physical channel setup is according to Annex C.3.2 for each of Cell 1 and Cell 2, respectively.

For CA with 2 DL CCs, the requirements are specified in Table 8.13.2.4.1-3, based on single carrier requirement specified in Table 8.13.2.4.1-2, with the addition of the parameters in Table 8.13.2.4.1-1 and the downlink physical channel setup according to Annex C.3.2.

**Table 8.13.2.4.1-1: Test Parameters for Testing CDM-multiplexed DM RS (single layer) with TM9 interference model for CA**

parameter		Unit	Cell 1	Cell 2
Downlink power allocation	$\rho_A$	dB	0	0
	$\rho_B$	dB	0 (Note 1)	0
	$\sigma$	dB	-3	-3
Cell-specific reference signals			Antenna ports 0,1	Antenna ports 0,1
CSI reference signals			Antenna ports 15,16	N/A
CSI-RS periodicity and subframe offset $T_{CSI-RS} / \Delta_{CSI-RS}$		Subframes	5 / 4	N/A
CSI reference signal configuration			0	N/A
$N_{oc}$ at antenna port		dBm/15kHz	-98	N/A
DIP (Note 2)		dB	N/A	-1.73
$BW_{channel}$		MHz	10	10
Cell Id			0	126
PDSCH transmission mode			9	9
Beamforming model			As specified in clause B.4.3 (Note 4, 5)	N/A
Interference model			N/A	As specified in clause B.5.4
Probability of occurrence of transmission rank in interfering cells	Rank 1		N/A	70
	Rank 2		N/A	30

Precoder update granularity	PRB	50	6
PMI delay (Note 5)	ms	10 or 11	N/A
Reporting interval	ms	5	N/A
Reporting mode		PUCCH 1-1	N/A
CodeBookSubsetRestriction bitmap		001111	N/A
Symbols for unused PRBs		OCNG (Note 6)	N/A
Simultaneous transmission		No simultaneous transmission on the other antenna port in (7 or 8) not used for the input signal under test	N/A
Physical channel for CQI reporting		PUSCH(Note 8)	N/A
cqi-pmi-ConfigurationIndex	TDD PCC	3	N/A
	TDD SCC	4	N/A
<p>Note 1: <math>P_{\beta} = 1</math></p> <p>Note 2: The respective received power spectral density of each interfering cell relative to <math>N_{oc}</math> is defined by its associated DIP value as specified in clause B.5.1.</p> <p>Note 3: The modulation symbols of the signal under test in Cell 1 are mapped onto antenna port 7 or 8.</p> <p>Note 4: The precoder in clause B.4.3 follows UE recommended PMI.</p> <p>Note 5: If the UE reports in an available uplink reporting instance at subframe SF#n based on PMI estimation at a downlink SF not later than SF#(n-4), this reported PMI cannot be applied at the eNB downlink before SF#(n+4).</p> <p>Note 6: These physical resource blocks are assigned to an arbitrary number of virtual UEs with one PDSCH per virtual UE; the data transmitted over the OCNG PDSCHs shall be uncorrelated pseudo random data, which is QPSK modulated.</p> <p>Note 7: All cells are time-synchronous.</p> <p>Note 8: To avoid collisions between CQI reports and HARQ-ACK it is necessary to report both on PUSCH instead of PUCCH. PDCCH DCI format 0 shall be transmitted in downlink SF#1, SF#4, SF#6 and #9 to allow periodic CQI to multiplex with the HARQ-ACK on PUSCH in uplink subframe SF#7, SF#8, SF#2 and #3.</p> <p>Note 9: ACK/NACK bits are transmitted using PUSCH with PUCCH format 1b with channel selection configured for tests with 2 CCs.</p>			

**Table 8.13.2.4.1-2: Single carrier performance for multiple CA configurations Enhanced Performance Requirement Type A, CDM-multiplexed DM RS**

Bandwidth	Reference Channel		OCNG Pattern		Propagation Conditions		Correlation Matrix and Antenna Configuration (Note 3)		Reference Value		
	2Rx CC	4Rx CC	Cell 1	Cell 2	Cell 1	Cell 2	2Rx CC	4Rx CC	Fraction of Maximum Throughput (%)	SINR (dB) (Note 2)	
										2Rx CC	4Rx CC
5MHz	R.76-1 TDD	R.76-4 TDD	OP.1 TDD	N/A	EVA5	EVA5	2x2 Low	2x4 Low	70	-0.6	-2.4
10 MHz	R.76 TDD	R.76-5 TDD	OP.1 TDD	N/A	EVA5	EVA5	2x2 Low	2x4 Low	70	-0.1	-2.1
15MHz	R.76-2 TDD	R.76-6 TDD	OP.1 TDD	N/A	EVA5	EVA5	2x2 Low	2x4 Low	70	-0.2	-2.1
20MHz	R.76-3 TDD	R.76-7 TDD	OP.1 TDD	N/A	EVA5	EVA5	2x2 Low	2x4 Low	70	-0.4	-2.1
<p>Note 1: The propagation conditions for Cell 1 and Cell 2 are statistically independent.</p> <p>Note 2: SINR corresponds to <math>E_s/N_{oc}</math> of Cell 1 as defined in clause 8.1.1.</p> <p>Note 3: Correlation matrix and antenna configuration parameters apply for each of Cell 1 and Cell 2.</p>											

**Table 8.13.2.4.1-3: Minimum performance (FRC) based on single carrier performance for CA with 2 DL CCs**

Test num.	CA Band-width combination	Requirement	UE category
1	2x20MHz	As specified in Table 8.13.2.4.1-2 per CC depending on either 2Rx CC or 4Rx CC	≥5
2	20MHz+15MHz	As specified in Table 8.13.2.4.1-2 per CC depending on either 2Rx CC or 4Rx CC	≥5

Note 1: The applicability of requirements for different CA configurations and bandwidth combination sets is defined in 8.1.2.6.

### 8.13.3 TDD-FDD (CA and DC)

The parameters specified in Table 8.13.3-1 are valid for all the TDD FDD CA tests unless otherwise stated.

**Table 8.13.3-1: Common Test Parameters**

Parameter	Unit	Value	
Uplink downlink configuration (Note 1) for TDD CC only		1	
Special subframe configuration (Note 2) for TDD CC only		4	
Inter-TTI Distance		1	
Maximum number of HARQ processes per component carrier	FDD PCell	Processes	8 for FDD and TDD CCs
	TDD PCell	Processes	11 for FDD CC; 7 for TDD CC
Maximum number of HARQ transmission		4	
Redundancy version coding sequence		{0,1,2,3} for QPSK and 16QAM {0,0,1,2} for 64QAM	
Number of OFDM symbols for PDCCH per component carrier	OFDM symbols	4 for 1.4 MHz bandwidth, 3 for 3 MHz and 5 MHz bandwidths, 2 for 10 MHz, 15 MHz and 20 MHz bandwidths	
Cyclic Prefix		Normal	
Cell_ID		0	
Cross carrier scheduling		Not configured	
ACK/NACK feedback mode		PUCCH format 3	
Downlink HARQ-ACK timing	FDD PCell		As specified in Clause 7.3.3 in TS36.213 [6]
	TDD PCell		As specified in Clause 7.3.4 in TS36.213 [6]

Note 1: as specified in Table 4.2-2 in TS 36.211 [4].  
Note 2: as specified in Table 4.2-1 in TS 36.211 [4].

The applicability of their requirements are specified in Clause 8.1.2.6. The single carrier performance with different bandwidths for multiple CA configurations specified in Clause 8.13.3 cannot be applied for UE single carrier test.

#### 8.13.3.1 Closed-loop spatial multiplexing performance 4Tx Antenna Port

##### 8.13.3.1.1 Minimum Requirement for FDD PCell

The purpose of these tests is to verify the closed loop rank-two performance with wideband and frequency selective precoding.

For TDD FDD CA with FDD PCell and 2DL CCs, the requirements are specified in Table 8.13.3.1.1-4 based on single carrier requirement specified in Table 8.13.3.1.1-2 and Table 8.13.3.1.1-3, with the addition of the parameters in Table 8.13.3.1.1-1 and the downlink physical channel setup according to Annex C.3.2.

For TDD FDD CA with FDD PCell and 3DL CCs, the requirements are specified in Table 8.13.3.1.1-5 based on single carrier requirement specified in Table 8.13.3.1.1-2 and Table 8.13.3.1.1-3, with the addition of the parameters in Table 8.13.3.1.1-1 and the downlink physical channel setup according to Annex C.3.2.

For TDD FDD CA with FDD PCell and 4DL CCs, the requirements are specified in Table 8.13.3.1.1-6 based on single carrier requirement specified in Table 8.13.3.1.1-2 and Table 8.13.3.1.1-3, with the addition of the parameters in Table 8.13.3.1.1-1 and the downlink physical channel setup according to Annex C.3.2.

For TDD FDD CA with FDD PCell and 5DL CCs, the requirements are specified in Table 8.13.3.1.1-7 based on single carrier requirement specified in Table 8.13.3.1.1-2 and Table 8.13.3.1.1-3, with the addition of the parameters in Table 8.13.3.1.1-1 and the downlink physical channel setup according to Annex C.3.2.

The test coverage for different number of component carriers is defined in 8.1.2.4.

**Table 8.13.3.1.1-1: Test Parameters for Multi-Layer Spatial Multiplexing (FRC) for CA**

Parameter		Unit	Value
Downlink power allocation	$\rho_A$	dB	-6
	$\rho_B$	dB	-6 (Note 1)
	$\sigma$	dB	3
$N_{oc}$ at antenna port		dBm/15kHz	-98
Precoding granularity		PRB	Wideband precoding for 1.4MHz, 4 for 3MHz and 5MHz CCs, 6 for 10MHz CCs, 8 for 15MHz and 20MHz CCs
PMI delay (Note 2)	FDD CC	ms	8
	TDD CC	ms	10 or 11
Reporting interval	FDD CC	ms	1
	TDD CC	ms	1 or 4 (Note 3)
Reporting mode			PUSCH 1-2
CodeBookSubsetRestriction bitmap			00000000000000000000000000000000 000011111111111111111100000000 00000000
CSI request field (Note 3)			'10'
PDSCH transmission mode			4
Note 1: $P_B = 1$ .			
Note 2: If the UE reports in an available uplink reporting instance at subframe SF#n based on PMI estimation at a downlink SF not later than SF#(n-4), this reported PMI cannot be applied at the eNB downlink before SF#(n+4).			
Note 3: Multiple CC-s under test are configured as the 1 <sup>st</sup> set of serving cells by higher layers.			
Note 4: ACK/NACK bits are transmitted using PUSCH with PUCCH format 3.			
Note 5: The same PDSCH transmission mode is applied to each component carrier.			



**Table 8.13.3.1.1-2: Single carrier performance with different bandwidths for multiple CA configurations for FDD PCell and SCell (FRC)**

Band - width	Reference channel		OCNG pattern	Propagation condition	Correlation matrix and antenna config.		Reference value		
	2Rx CC	4Rx CC			2Rx CC	4Rx CC	Fraction of maximum throughput (%)	SNR (dB)	
								2Rx CC	4Rx CC
1.4M Hz	R.14-4 FDD	R.14-4 FDD	OP.1 FDD	EVA5	4x2 Low	4x4 Low	70	10.4	7.5
3MHz	R.14-5 FDD	R.14-5 FDD	OP.1 FDD	EVA5	4x2 Low	4x4 Low	70	9.5	5.1
5MHz	R.14-6 FDD	R.14-6 FDD	OP.1 FDD	EVA5	4x2 Low	4x4 Low	70	9.5	5.2
10 MHz	R.14 FDD	R.14 FDD	OP.1 FDD	EVA5	4x2 Low	4x4 Low	70	10.1	5.7
15M Hz	R.14-7 FDD	R.14-7 FDD	OP.1 FDD	EVA5	4x2 Low	4x4 Low	70	10.1	5.6
20M Hz	R.14-3 FDD	R.14-3 FDD	OP.1 FDD	EVA5	4x2 Low	4x4 Low	70	10.3	5.6

**Table 8.13.3.1.1-3: Single carrier performance with different bandwidths for multiple CA configurations for TDD SCell (FRC)**

Band - width	Reference channel		OCNG pattern	Propagation condition	Correlation matrix and antenna config.		Reference value		
	2Rx CC	4Rx CC			2Rx CC	4Rx CC	Fraction of maximum throughput (%)	SNR (dB)	
								2Rx CC	4Rx CC
1.4M Hz	R.43-1 TDD	R.43-1 TDD	OP.1 TDD	EVA5	4x2 Low	4x4 Low	70	11.0	8.1
3MHz	R.43-2 TDD	R.43-2 TDD	OP.1 TDD	EVA5	4x2 Low	4x4 Low	70	9.8	5.4
5MHz	R.43-3 TDD	R.43-3 TDD	OP.1 TDD	EVA5	4x2 Low	4x4 Low	70	10.0	5.9
10 MHz	R.43-4 TDD	R.43-4 TDD	OP.1 TDD	EVA5	4x2 Low	4x4 Low	70	10.5	6.3
15M Hz	R.43-5 TDD	R.43-5 TDD	OP.1 TDD	EVA5	4x2 Low	4x4 Low	70	10.6	6.2
20M Hz	R.43 TDD	R.43 TDD	OP.1 TDD	EVA5	4x2 Low	4x4 Low	70	10.7	6.4

**Table 8.13.3.1.1-4: Minimum performance for multiple CA configurations with 2DL CCs (FRC)**

Test number	Aggregated Bandwidth (MHz)			Minimum performance requirement	UE Category
	Total	FDD CC	TDD CC		
1	2x20	20	20	As defined in Table 8.13.3.1.1-2 and Table 8.13.3.1.1-3 per CC	≥5
2	20+10	10	20	As defined in Table 8.13.3.1.1-2 and Table 8.13.3.1.1-3 per CC	≥5
3	20+15	15	20	As defined in Table 8.13.3.1.1-2 and Table 8.13.3.1.1-3 per CC	≥5
Note 1:	The applicability of requirements for different CA configurations and bandwidth combination sets is defined in 8.1.2.6.				

Table 8.13.3.1.1-5: Minimum performance for multiple CA configurations with 3DL CCs (FRC)

Test number	Aggregated Bandwidth (MHz)			Minimum performance requirement	UE Category
	Total	FDD CC	TDD CC		
1	3x20	20	2x20	As defined in Table 8.13.3.1.1-2 and Table 8.13.3.1.1-3 per CC	≥5
2	20+20+15	15	2x20	As defined in Table 8.13.3.1.1-2 and Table 8.13.3.1.1-3 per CC	≥5
3	20+20+10	10	2x20	As defined in Table 8.13.3.1.1-2 and Table 8.13.3.1.1-3 per CC	≥5
4	3x20	2x20	20	As defined in Table 8.13.3.1.1-2 and Table 8.13.3.1.1-3 per CC	≥5
5	20+20+15	20+15	20	As defined in Table 8.13.3.1.1-2 and Table 8.13.3.1.1-3 per CC	≥5
6	20+20+10	20+10	20	As defined in Table 8.13.3.1.1-2 and Table 8.13.3.1.1-3 per CC	≥5
7	20+10+10	2x10	20	As defined in Table 8.13.3.1.1-2 and Table 8.13.3.1.1-3 per CC	≥5
8	10+15+20	10	15+20	As defined in Table 8.13.3.1.1-2 and Table 8.13.3.1.1-3 per CC	≥5
9	10+15+20	10+15	20	As defined in Table 8.13.3.1.1-2 and Table 8.13.3.1.1-3 per CC	≥5

Note 1: The applicability of requirements for different CA configurations and bandwidth combination sets is defined in 8.1.2.6.

Table 8.13.3.1.1-6: Minimum performance for multiple CA configurations with 4DL CCs (FRC)

Test number	Aggregated Bandwidth (MHz)			Minimum performance requirement	UE Category
	Total	FDD CC	TDD CC		
1	4x20	20	3x20	As defined in Table 8.13.3.1.1-2 and Table 8.13.3.1.1-3 per CC	≥8
2	4x20	2x20	2x20	As defined in Table 8.13.3.1.1-2 and Table 8.13.3.1.1-3 per CC	≥8
3	3x20+15	20+15	2x20	As defined in Table 8.13.3.1.1-2 and Table 8.13.3.1.1-3 per CC	≥8
4	2x15+2x20	2x15	2x20	As defined in Table 8.13.3.1.1-2 and Table 8.13.3.1.1-3 per CC	≥8
5	3x20+15	2x20+15	20	As defined in Table 8.13.3.1.1-2 and Table 8.13.3.1.1-3 per CC	≥8
6	2x15+2x20	2x15+20	20	As defined in Table 8.13.3.1.1-2 and Table 8.13.3.1.1-3 per CC	≥8
7	3x20+10	2x20+10	20	As defined in Table 8.13.3.1.1-2 and Table 8.13.3.1.1-3 per CC	≥8
8	4x20	3x20	20	As defined in Table 8.13.3.1.1-2 and Table 8.13.3.1.1-3 per CC	≥8
9	10+3x20	10	3x20	As defined in Table 8.13.3.1.1-2 and Table 8.13.3.1.1-3 per CC	≥8
10	2x10+2x20	2x10	2x20	As defined in Table 8.13.3.1.1-2 and Table 8.13.3.1.1-3 per CC	≥8
11	2x10+20+15	2x10	20+15	As defined in Table 8.13.3.1.1-2 and Table 8.13.3.1.1-3 per CC	≥8
12	10+3x20	10+20	2x20	As defined in Table 8.13.3.1.1-2 and Table 8.13.3.1.1-3 per CC	≥8
13	10+15+2x20	10+15	2x20	As defined in Table 8.13.3.1.1-2 and Table 8.13.3.1.1-3 per CC	≥8
14	10+15+2x20	10+15+20	20	As defined in Table 8.13.3.1.1-2 and Table 8.13.3.1.1-3 per CC	≥8

Note 1: The applicability of requirements for different CA configurations and bandwidth combination sets is defined in 8.1.2.6.

Table 8.13.3.1.1-7: Minimum performance for multiple CA configurations with 5DL CCs (FRC)

Test number	Aggregated Bandwidth (MHz)			Minimum performance requirement	UE Category
	Total	FDD CC	TDD CC		
1	15+4x20	15+2x20	2x20	As defined in Table 8.13.3.1.1-2 and Table 8.13.3.1.1-3 per CC	8, ≥11
2	2x15+3x20	2x15+20	2x20	As defined in Table 8.13.3.1.1-2 and Table 8.13.3.1.1-3 per CC	8, ≥11
3	4x20+20	4x20	20	As defined in Table 8.13.3.1.1-2 and Table 8.13.3.1.1-3 per CC	8, ≥11
4	3x20+2x20	3x20	2x20	As defined in Table 8.13.3.1.1-2 and Table 8.13.3.1.1-3 per CC	8, ≥11
5	2x20+3x20	2x20	3x20	As defined in Table 8.13.3.1.1-2 and Table 8.13.3.1.1-3 per CC	8, ≥11
6	20+4x20	20	4x20	As defined in Table 8.13.3.1.1-2 and Table 8.13.3.1.1-3 per CC	8, ≥11
7	10+4x20	10	4x20	As defined in Table 8.13.3.1.1-2 and Table 8.13.3.1.1-3 per CC	8, ≥11
8	10+20+3x20	10+20	3x20	As defined in Table 8.13.3.1.1-2 and Table 8.13.3.1.1-3 per CC	8, ≥11
9	2x10+3x20	2x10	3x20	As defined in Table 8.13.3.1.1-2 and Table 8.13.3.1.1-3 per CC	8, ≥11
10	10+2x20+2x20	10+2x20	2x20	As defined in Table 8.13.3.1.1-2 and Table 8.13.3.1.1-3 per CC	8, ≥11
11	10+15+20+2x20	10+15+20	2x20	As defined in Table 8.13.3.1.1-2 and Table 8.13.3.1.1-3 per CC	8, ≥11

Note 1: The applicability of requirements for different CA configurations and bandwidth combination sets is defined in 8.1.2.6.

### 8.13.3.1.2 Minimum Requirement for TDD PCell

The purpose of these tests is to verify the closed loop rank-two performance with wideband and frequency selective precoding.

For TDD FDD CA with TDD PCell and 2DL CCs, the requirements are specified in Table 8.13.3.1.2-4 based on single carrier requirement specified in Table 8.13.3.1.2-2 and Table 8.13.3.1.2-3, with the addition of the parameters in Table 8.13.3.1.2-1 and the downlink physical channel setup according to Annex C.3.2.

For TDD FDD CA with TDD PCell and 3DL CCs, the requirements are specified in Table 8.13.3.1.2-5 based on single carrier requirement specified in Table 8.13.3.1.2-2 and Table 8.13.3.1.2-3, with the addition of the parameters in Table 8.13.3.1.2-1 and the downlink physical channel setup according to Annex C.3.2.

For TDD FDD CA with TDD PCell and 4DL CCs, the requirements are specified in Table 8.13.3.1.2-6 based on single carrier requirement specified in Table 8.13.3.1.2-2 and Table 8.13.3.1.2-3, with the addition of the parameters in Table 8.13.3.1.2-1 and the downlink physical channel setup according to Annex C.3.2.

For TDD FDD CA with TDD PCell and 5DL CCs, the requirements are specified in Table 8.13.3.1.2-7 based on single carrier requirement specified in Table 8.13.3.1.2-2 and Table 8.13.3.1.2-3, with the addition of the parameters in Table 8.13.3.1.2-1 and the downlink physical channel setup according to Annex C.3.2.

The test coverage for different number of component carriers is defined in 8.1.2.4.

**Table 8.13.3.1.2-1: Test Parameters for Multi-Layer Spatial Multiplexing (FRC) for CA**

Parameter		Unit	Value
Downlink power allocation	$\rho_A$	dB	-6
	$\rho_B$	dB	-6 (Note 1)
	$\sigma$	dB	3
$N_{oc}$ at antenna port		dBm/15kHz	-98
Precoding granularity		PRB	Widelband pre-coding for 1.4MHz, 4 for 3MHz and 5MHz CCs, 6 for 10MHz CCs, 8 for 15MHz and 20MHz CCs
PMI delay (Note 2)	FDD CC	ms	8
	TDD CC	ms	10 or 11
Reporting interval	FDD CC	ms	1
	TDD CC	ms	1 or 4 (Note 3)
Reporting mode			PUSCH 1-2
CodeBookSubsetRestriction bitmap			00000000000000000000000000000000 0000111111111111111111111100000000 00000000
CSI request field (Note 3)			'10'
PDSCH transmission mode			TM4
Note 1: $P_B = 1$ .			
Note 2: If the UE reports in an available uplink reporting instance at subframe SF#n based on PMI estimation at a downlink SF not later than SF#(n-4), this reported PMI cannot be applied at the eNB downlink before SF#(n+4).			
Note 3: Multiple CC-s under test are configured as the 1 <sup>st</sup> set of serving cells by higher layers.			
Note 4: ACK/NACK bits are transmitted using PUSCH with PUCCH format 3.			
Note 5: The same PDSCH transmission mode is applied to each component carrier.			

**Table 8.13.3.1.2-2: Single carrier performance with different bandwidths for multiple CA configurations for FDD SCell (FRC)**

Band - width	Reference channel		OCNG pattern	Propagation condition	Correlation matrix and antenna config.		Reference value		
	2Rx CC	4Rx CC			2Rx CC	4Rx CC	Fraction of maximum throughput (%)	SNR (dB)	
								2Rx CC	4Rx CC
1.4M Hz	R.14-4 FDD	R.14-4 FDD	OP.1 FDD	EVA5	4x2 Low	4x4 Low	70	10.4	7.5
3MHz	R.14-5 FDD	R.14-5 FDD	OP.1 FDD	EVA5	4x2 Low	4x4 Low	70	9.5	5.1
5MHz	R.14-6 FDD	R.14-6 FDD	OP.1 FDD	EVA5	4x2 Low	4x4 Low	70	9.5	5.2
10 MHz	R.14 FDD	R.14 FDD	OP.1 FDD	EVA5	4x2 Low	4x4 Low	70	10.1	5.7
15M Hz	R.14-7 FDD	R.14-7 FDD	OP.1 FDD	EVA5	4x2 Low	4x4 Low	70	10.1	5.6
20M Hz	R.14-3 FDD	R.14-3 FDD	OP.1 FDD	EVA5	4x2 Low	4x4 Low	70	10.3	5.6

**Table 8.13.3.1.2-3: Single carrier performance with different bandwidths for multiple CA configurations for TDD PCell and SCell (FRC)**

Band - width	Reference channel		OCNG pattern	Propagation condition	Correlation matrix and antenna config.		Reference value		
	2Rx CC	4Rx CC			2Rx CC	4Rx CC	Fraction of maximum throughput (%)	SNR (dB)	
								2Rx CC	4Rx CC
1.4M Hz	R.43-1 TDD	R.43-1 TDD	OP.1 TDD	EVA5	4x2 Low	4x4 Low	70	11.0	8.1
3MHz	R.43-2 TDD	R.43-2 TDD	OP.1 TDD	EVA5	4x2 Low	4x4 Low	70	9.8	5.4
5MHz	R.43-3 TDD	R.43-3 TDD	OP.1 TDD	EVA5	4x2 Low	4x4 Low	70	10.0	5.9
10 MHz	R.43-4 TDD	R.43-4 TDD	OP.1 TDD	EVA5	4x2 Low	4x4 Low	70	10.5	6.3
15M Hz	R.43-5 TDD	R.43-5 TDD	OP.1 TDD	EVA5	4x2 Low	4x4 Low	70	10.6	6.2
20M Hz	R.43 TDD	R.43 TDD	OP.1 TDD	EVA5	4x2 Low	4x4 Low	70	10.7	6.4

**Table 8.13.3.1.2-4: Minimum performance for multiple CA configurations with 2DL CCs (FRC)**

Test number	Aggregated Bandwidth (MHz)			Minimum performance requirement	UE Category
	Total	FDD CC	TDD CC		
1	2x20	20	20	As defined in Table 8.13.3.1.2-2 and Table 8.13.3.1.2-3 per CC	≥5
2	20+10	10	20	As defined in Table 8.13.3.1.2-2 and Table 8.13.3.1.2-3 per CC	≥5
3	20+15	15	20	As defined in Table 8.13.3.1.1-2 and Table 8.13.3.1.1-3 per CC	≥5

Note 1: The applicability of requirements for different CA configurations and bandwidth combination sets is defined in 8.1.2.6.

**Table 8.13.3.1.2-5: Minimum performance for multiple CA configurations with 3DL CCs (FRC)**

Test number	Aggregated Bandwidth (MHz)			Minimum performance requirement	UE Category
	Total	FDD CC	TDD CC		
1	3x20	20	2x20	As defined in Table 8.13.3.1.2-2 and Table 8.13.3.1.2-3 per CC	≥5
2	20+20+15	15	2x20	As defined in Table 8.13.3.1.2-2 and Table 8.13.3.1.2-3 per CC	≥5
3	20+20+10	10	2x20	As defined in Table 8.13.3.1.2-2 and Table 8.13.3.1.2-3 per CC	≥5
4	3x20	2x20	20	As defined in Table 8.13.3.1.2-2 and Table 8.13.3.1.2-3 per CC	≥5
5	20+20+15	20+15	20	As defined in Table 8.13.3.1.2-2 and Table 8.13.3.1.2-3 per CC	≥5
6	20+20+10	20+10	20	As defined in Table 8.13.3.1.2-2 and Table 8.13.3.1.2-3 per CC	≥5
7	20+10+10	2x10	20	As defined in Table 8.13.3.1.2-2 and Table 8.13.3.1.2-3 per CC	≥5
8	10+15+20	10	15+20	As defined in Table 8.13.3.1.2-2 and Table 8.13.3.1.2-3 per CC	≥5
9	10+15+20	10+15	20	As defined in Table 8.13.3.1.2-2 and Table 8.13.3.1.2-3 per CC	≥5

Note 1: The applicability of requirements for different CA configurations and bandwidth combination sets is defined in 8.1.2.6.

Table 8.13.3.1.2-6: Minimum performance for multiple CA configurations with 4DL CCs (FRC)

Test number	Aggregated Bandwidth (MHz)			Minimum performance requirement	UE Category
	Total	FDD CC	TDD CC		
1	4x20	20	3x20	As defined in Table 8.13.3.1.2-2 and Table 8.13.3.1.2-3 per CC	≥8
2	4x20	2x20	2x20	As defined in Table 8.13.3.1.2-2 and Table 8.13.3.1.2-3 per CC	≥8
3	3x20+15	20+15	2x20	As defined in Table 8.13.3.1.2-2 and Table 8.13.3.1.2-3 per CC	≥8
4	2x15+2x20	2x15	2x20	As defined in Table 8.13.3.1.2-2 and Table 8.13.3.1.2-3 per CC	≥8
5	3x20+15	2x20+15	20	As defined in Table 8.13.3.1.2-2 and Table 8.13.3.1.2-3 per CC	≥8
6	2x15+2x20	2x15+20	20	As defined in Table 8.13.3.1.2-2 and Table 8.13.3.1.2-3 per CC	≥8
7	3x20+10	2x20+10	20	As defined in Table 8.13.3.1.2-2 and Table 8.13.3.1.2-3 per CC	≥8
8	4x20	3x20	20	As defined in Table 8.13.3.1.2-2 and Table 8.13.3.1.2-3 per CC	≥8
9	10+3x20	10	3x20	As defined in Table 8.13.3.1.2-2 and Table 8.13.3.1.2-3 per CC	≥8
10	2x10+2x20	2x10	2x20	As defined in Table 8.13.3.1.2-2 and Table 8.13.3.1.2-3 per CC	≥8
11	2x10+20+15	2x10	20+15	As defined in Table 8.13.3.1.2-2 and Table 8.13.3.1.2-3 per CC	≥8
12	10+3x20	10+20	2x20	As defined in Table 8.13.3.1.2-2 and Table 8.13.3.1.2-3 per CC	≥8
13	10+15+2x20	10+15	2x20	As defined in Table 8.13.3.1.2-2 and Table 8.13.3.1.2-3 per CC	≥8
14	10+15+2x20	10+15+20	20	As defined in Table 8.13.3.1.2-2 and Table 8.13.3.1.2-3 per CC	≥8

Note 1: The applicability of requirements for different CA configurations and bandwidth combination sets is defined in 8.1.2.6.

Table 8.13.3.1.2-7: Minimum performance for multiple CA configurations with 5DL CCs (FRC)

Test number	Aggregated Bandwidth (MHz)			Minimum performance requirement	UE Category
	Total	FDD CC	TDD CC		
1	15+4x20	15+2x20	2x20	As defined in Table 8.13.3.1.2-2 and Table 8.13.3.1.2-3 per CC	8, ≥11
2	2x15+3x20	2x15+20	2x20	As defined in Table 8.13.3.1.2-2 and Table 8.13.3.1.2-3 per CC	8, ≥11
3	4x20+20	4x20	20	As defined in Table 8.13.3.1.2-2 and Table 8.13.3.1.2-3 per CC	8, ≥11
4	3x20+2x20	3x20	2x20	As defined in Table 8.13.3.1.2-2 and Table 8.13.3.1.2-3 per CC	8, ≥11
5	2x20+3x20	2x20	3x20	As defined in Table 8.13.3.1.2-2 and Table 8.13.3.1.2-3 per CC	8, ≥11
6	20+4x20	20	4x20	As defined in Table 8.13.3.1.2-2 and Table 8.13.3.1.2-3 per CC	8, ≥11
7	10+4x20	10	4x20	As defined in Table 8.13.3.1.2-2 and Table 8.13.3.1.2-3 per CC	8, ≥11
8	10+20+3x20	10+20	3x20	As defined in Table 8.13.3.1.2-2 and Table 8.13.3.1.2-3 per CC	8, ≥11
9	2x10+3x20	2x10	3x20	As defined in Table 8.13.3.1.2-2 and Table 8.13.3.1.2-3 per CC	8, ≥11
10	10+2x20+2x20	10+2x20	2x20	As defined in Table 8.13.3.1.2-2 and Table 8.13.3.1.2-3 per CC	8, ≥11
11	10+15+20+2x20	10+15+20	2x20	As defined in Table 8.13.3.1.2-2 and Table 8.13.3.1.2-3 per CC	8, ≥11

Note 1: The applicability of requirements for different CA configurations and bandwidth combination sets is defined in 8.1.2.6.

### 8.13.3.2 Dual-Layer Spatial Multiplexing (User-Specific Reference Symbols)

#### 8.13.3.2.1 Minimum Requirement Dual-Layer Spatial Multiplexing 2 Tx Antenna Port for FDD PCell

The purpose of these tests is to verify dual-layer transmission on antenna ports 7 and 8 upon detection of a PDCCH with DCI format 2C.

For TDD FDD CA with FDD PCell and 2DL CCs, the requirements are specified in Table 8.13.3.2.1-4 based on single carrier requirement specified in Table 8.13.3.2.1-2 and Table 8.13.3.2.1-3, with the addition of the parameters in Table 8.13.3.2.1-1 and the downlink physical channel setup according to Annex C.3.2.

For TDD FDD CA with FDD PCell and 3DL CCs, the requirements are specified in Table 8.13.3.2.1-5 based on single carrier requirement specified in Table 8.13.3.2.1-2 and Table 8.13.3.2.1-3, with the addition of the parameters in Table 8.13.3.2.1-1 and the downlink physical channel setup according to Annex C.3.2.

For TDD FDD CA with FDD PCell and 4DL CCs, the requirements are specified in Table 8.13.3.2.1-6 based on single carrier requirement specified in Table 8.13.3.2.1-2 and Table 8.13.3.2.1-3, with the addition of the parameters in Table 8.13.3.2.1-1 and the downlink physical channel setup according to Annex C.3.2.

For TDD FDD CA with FDD PCell and 5DL CCs, the requirements are specified in Table 8.13.3.2.1-7 based on single carrier requirement specified in Table 8.13.3.2.1-2 and Table 8.13.3.2.1-3, with the addition of the parameters in Table 8.13.3.2.1-1 and the downlink physical channel setup according to Annex C.3.2.

The test coverage for different number of component carriers is defined in 8.1.2.4.

**Table 8.13.3.2.1-1: Test Parameters for Multi-Layer Spatial Multiplexing (FRC) for CA**

Parameter	Unit	Values	
Downlink power allocation	$\rho_A$	dB	0
	$\rho_B$	dB	0 (Note 1)
	$\sigma$	dB	-3
Cell-specific reference signals		Antenna ports 0 and 1	
Cell ID		0	
CSI reference signals		Antenna ports 15,16	
Beamforming model		Annex B.4.2	
CSI-RS periodicity and subframe offset $T_{\text{CSI-RS}} / \Delta_{\text{CSI-RS}}$	FDD CC	Subframes	5 / 2
	TDD CC		5 / 4
CSI reference signal configuration		8	
Zero-power CSI-RS configuration $l_{\text{CSI-RS}} / \text{ZeroPowerCSI-RS}$ bitmap	FDD CC	Subframes / bitmap	3 / 0010000000000000
	TDD CC		4 / 0010000000000000
$N_{oc}$ at antenna port	dBm/15kHz	-98	
$E_s / N_{oc}$	FDD CC		Reference Value in Table 8.13.3.2.1-2
	TDD CC		Reference Value in Table 8.13.3.2.1-3
Symbols for unused PRBs		OCNG (Note 2)	
Number of allocated resource blocks (Note 2)	PRB	50	
Simultaneous transmission		No	
PDSCH transmission mode		9	
Note 1: $P_B = 1$			
Note 2: These physical resource blocks are assigned to an arbitrary number of virtual UEs with one PDSCH per virtual UE; the data transmitted over the OCNG PDSCHs shall be uncorrelated pseudo random data, which is QPSK modulated.			
Note 3: ACK/NACK bits are transmitted using PUSCH with PUCCH format 3.			

**Table 8.13.3.2.1-2: Single carrier performance with different bandwidths for multiple CA configurations for FDD PCell and SCell (FRC)**

Band - width	Reference channel		OCNG pattern	Propagation condition	Correlation matrix and antenna config.		Reference value		
	2Rx CC	4Rx CC			2Rx CC	4Rx CC	Fraction of maximum throughput (%)	SNR (dB)	
								2Rx CC	4Rx CC
5MHz	R.51-2 FDD	R.51-2 FDD	OP.1 FDD	ETU5	2x2 Low	2x4 Low	70	14.2	9.0
10 MHz	R.51 FDD	R.51 FDD	OP.1 FDD	ETU5	2x2 Low	2x4 Low	70	13.7	8.8
15M Hz	R.51-3 FDD	R.51-3 FDD	OP.1 FDD	ETU5	2x2 Low	2x4 Low	70	13.6	8.7
20M Hz	R.51-4 FDD	R.51-4 FDD	OP.1 FDD	ETU5	2x2 Low	2x4 Low	70	14.3	8.8

Note 1: The propagation conditions for Cell 1 and Cell 2 are statistically independent.  
Note 2: Correlation matrix and antenna configuration parameters apply for each of Cell 1 and Cell 2.  
Note 3: SNR corresponds to  $\hat{E}_s/N_{oc}$  of Cell 1.

**Table 8.13.3.2.1-3: Single carrier performance with different bandwidths for multiple CA configurations for TDD SCell (FRC)**

Band - width	Reference channel		OCNG pattern	Propagation condition	Correlation matrix and antenna config.		Reference value		
	2Rx CC	4Rx CC			2Rx CC	4Rx CC	Fraction of maximum throughput (%)	SNR (dB)	
								2Rx CC	4Rx CC
5MHz	R.51-2 TDD	R.51-2 TDD	OP.1 TDD	ETU5	2x2 Low	2x4 Low	70	14.0	9.0
10 MHz	R.51 TDD	R.51 TDD	OP.1 TDD	ETU5	2x2 Low	2x4 Low	70	13.9	9.1
15M Hz	R.51-3 TDD	R.51-3 TDD	OP.1 TDD	ETU5	2x2 Low	2x4 Low	70	13.9	9.2
20M Hz	R.51-4 TDD	R.51-4 TDD	OP.1 TDD	ETU5	2x2 Low	2x4 Low	70	14.1	9.3

Note 1: The propagation conditions for Cell 1 and Cell 2 are statistically independent.  
Note 2: Correlation matrix and antenna configuration parameters apply for each of Cell 1 and Cell 2.  
Note 3: SNR corresponds to  $\hat{E}_s/N_{oc}$  of Cell 1.

**Table 8.13.3.2.1-4: Minimum performance for multiple CA configurations with 2DL CCs (FRC)**

Test number	Aggregated Bandwidth (MHz)			Minimum performance requirement	UE Category
	Total	FDD CC	TDD CC		
1	2x20	20	20	As defined in Table 8.13.3.2.1-2 and Table 8.13.3.2.1-3 per CC	≥5
2	20+10	10	20	As defined in Table 8.13.3.2.1-2 and Table 8.13.3.2.1-3 per CC	≥5
3	20+15	15	20	As defined in Table 8.13.3.2.1-2 and Table 8.13.3.2.1-3 per CC	≥5

Note 1: The applicability of requirements for different CA configurations and bandwidth combination sets is defined in 8.1.2.6.



Table 8.13.3.2.1-5: Minimum performance for multiple CA configurations with 3DL CCs (FRC)

Test number	Aggregated Bandwidth (MHz)			Minimum performance requirement	UE Category
	Total	FDD CC	TDD CC		
1	3x20	20	2x20	As defined in Table 8.13.3.2.1-2 and Table 8.13.3.2.1-3 per CC	≥5
2	20+20+15	15	2x20	As defined in Table 8.13.3.2.1-2 and Table 8.13.3.2.1-3 per CC	≥5
3	20+20+10	10	2x20	As defined in Table 8.13.3.2.1-2 and Table 8.13.3.2.1-3 per CC	≥5
4	3x20	2x20	20	As defined in Table 8.13.3.2.1-2 and Table 8.13.3.2.1-3 per CC	≥5
5	20+20+15	20+15	20	As defined in Table 8.13.3.2.1-2 and Table 8.13.3.2.1-3 per CC	≥5
6	20+20+10	20+10	20	As defined in Table 8.13.3.2.1-2 and Table 8.13.3.2.1-3 per CC	≥5
7	20+10+10	2x10	20	As defined in Table 8.13.3.2.1-2 and Table 8.13.3.2.1-3 per CC	≥5
8	10+15+20	10	15+20	As defined in Table 8.13.3.2.1-2 and Table 8.13.3.2.1-3 per CC	≥5
9	10+15+20	10+15	20	As defined in Table 8.13.3.2.1-2 and Table 8.13.3.2.1-3 per CC	≥5

Note 1: The applicability of requirements for different CA configurations and bandwidth combination sets is defined in 8.1.2.6.

Table 8.13.3.2.1-6: Minimum performance for multiple CA configurations with 4DL CCs (FRC)

Test number	Aggregated Bandwidth (MHz)			Minimum performance requirement	UE Category
	Total	FDD CC	TDD CC		
1	4x20	20	3x20	As defined in Table 8.13.3.2.1-2 and Table 8.13.3.2.1-3 per CC	≥8
2	4x20	2x20	2x20	As defined in Table 8.13.3.2.1-2 and Table 8.13.3.2.1-3 per CC	≥8
3	3x20+15	20+15	2x20	As defined in Table 8.13.3.2.1-2 and Table 8.13.3.2.1-3 per CC	≥8
4	2x15+2x20	2x15	2x20	As defined in Table 8.13.3.2.1-2 and Table 8.13.3.2.1-3 per CC	≥8
5	3x20+15	2x20+15	20	As defined in Table 8.13.3.2.1-2 and Table 8.13.3.2.1-3 per CC	≥8
6	2x15+2x20	2x15+20	20	As defined in Table 8.13.3.2.1-2 and Table 8.13.3.2.1-3 per CC	≥8
7	3x20+10	2x20+10	20	As defined in Table 8.13.3.2.1-2 and Table 8.13.3.2.1-3 per CC	≥8
8	4x20	3x20	20	As defined in Table 8.13.3.1.2-2 and Table 8.13.3.1.2-3 per CC	≥8
9	10+3x20	10	3x20	As defined in Table 8.13.3.1.2-2 and Table 8.13.3.1.2-3 per CC	≥8
10	2x10+2x20	2x10	2x20	As defined in Table 8.13.3.1.2-2 and Table 8.13.3.1.2-3 per CC	≥8
11	2x10+20+15	2x10	20+15	As defined in Table 8.13.3.1.2-2 and Table 8.13.3.1.2-3 per CC	≥8
12	10+3x20	10+20	2x20	As defined in Table 8.13.3.1.2-2 and Table 8.13.3.1.2-3 per CC	≥8
13	10+15+2x20	10+15	2x20	As defined in Table 8.13.3.1.2-2 and Table 8.13.3.1.2-3 per CC	≥8
14	10+15+2x20	10+15+20	20	As defined in Table 8.13.3.1.2-2 and Table 8.13.3.1.2-3 per CC	≥8

Note 1: The applicability of requirements for different CA configurations and bandwidth combination sets is defined in 8.1.2.6.

Table 8.13.3.2.1-7: Minimum performance for multiple CA configurations with 5DL CCs (FRC)

Test number	Aggregated Bandwidth (MHz)			Minimum performance requirement	UE Category
	Total	FDD CC	TDD CC		
1	15+4x20	15+2x20	2x20	As defined in Table 8.13.3.2.1-2 and Table 8.13.3.2.1-3 per CC	8, ≥11
2	2x15+3x20	2x15+20	2x20	As defined in Table 8.13.3.2.1-2 and Table 8.13.3.2.1-3 per CC	8, ≥11
3	4x20+20	4x20	20	As defined in Table 8.13.3.2.1-2 and Table 8.13.3.2.1-3 per CC	8, ≥11
4	3x20+2x20	3x20	2x20	As defined in Table 8.13.3.2.1-2 and Table 8.13.3.2.1-3 per CC	8, ≥11
5	2x20+3x20	2x20	3x20	As defined in Table 8.13.3.2.1-2 and Table 8.13.3.2.1-3 per CC	8, ≥11
6	20+4x20	20	4x20	As defined in Table 8.13.3.2.1-2 and Table 8.13.3.2.1-3 per CC	8, ≥11
7	10+4x20	10	4x20	As defined in Table 8.13.3.2.1-2 and Table 8.13.3.2.1-3 per CC	8, ≥11
8	10+20+3x20	10+20	3x20	As defined in Table 8.13.3.2.1-2 and Table 8.13.3.2.1-3 per CC	8, ≥11
9	2x10+3x20	2x10	3x20	As defined in Table 8.13.3.2.1-2 and Table 8.13.3.2.1-3 per CC	8, ≥11
10	10+2x20+2x20	10+2x20	2x20	As defined in Table 8.13.3.2.1-2 and Table 8.13.3.2.1-3 per CC	8, ≥11
11	10+15+20+2x20	10+15+20	2x20	As defined in Table 8.13.3.2.1-2 and Table 8.13.3.2.1-3 per CC	8, ≥11

Note 1: The applicability of requirements for different CA configurations and bandwidth combination sets is defined in 8.1.2.6.

### 8.13.3.2.2 Minimum Requirement Dual-Layer Spatial Multiplexing 2 Tx Antenna Port for TDD PCell

The purpose of these tests is to verify the closed loop rank-two performance with wideband and frequency selective precoding.

For TDD FDD CA with TDD PCell and 2DL CCs, the requirements are specified in Table 8.13.3.2.2-4 based on single carrier requirement specified in Table 8.13.3.2.2-2 and Table 8.13.3.2.2-3, with the addition of the parameters in Table 8.13.3.2.2-1 and the downlink physical channel setup according to Annex C.3.2.

For TDD FDD CA with TDD PCell and 3DL CCs, the requirements are specified in Table 8.13.3.2.2-5 based on single carrier requirement specified in Table 8.13.3.2.2-2 and Table 8.13.3.2.2-3, with the addition of the parameters in Table 8.13.3.2.2-1 and the downlink physical channel setup according to Annex C.3.2.

For TDD FDD CA with TDD PCell and 4DL CCs, the requirements are specified in Table 8.13.3.2.2-6 based on single carrier requirement specified in Table 8.13.3.2.2-2 and Table 8.13.3.2.2-3, with the addition of the parameters in Table 8.13.3.2.2-1 and the downlink physical channel setup according to Annex C.3.2.

For TDD FDD CA with TDD PCell and 5DL CCs, the requirements are specified in Table 8.13.3.2.2-7 based on single carrier requirement specified in Table 8.13.3.2.2-2 and Table 8.13.3.2.2-3, with the addition of the parameters in Table 8.13.3.2.2-1 and the downlink physical channel setup according to Annex C.3.2.

The test coverage for different number of component carriers is defined in 8.1.2.4.

**Table 8.13.3.2.2-1: Test Parameters for Multi-Layer Spatial Multiplexing (FRC) for CA**

Parameter		Unit	Values
Downlink power allocation	$\rho_A$	dB	0
	$\rho_B$	dB	0 (Note 1)
	$\sigma$	dB	-3
Cell-specific reference signals			Antenna ports 0 and 1
Cell ID			0
CSI reference signals			Antenna ports 15,16
Beamforming model			Annex B.4.2
CSI-RS periodicity and subframe offset $T_{CSI-RS} / \Delta_{CSI-RS}$	FDD CC	Subframes	5 / 2
	TDD CC		5 / 4
CSI reference signal configuration			8
Zero-power CSI-RS configuration $l_{CSI-RS} / ZeroPowerCSI-RS$ bitmap	FDD CC	Subframes / bitmap	3 / 0010000000000000
	TDD CC		4 / 0010000000000000
$N_{oc}$ at antenna port		dBm/15kHz	-98
$E_s / N_{oc}$	FDD CC		Reference Value in Table 8.13.3.2.2-2
	TDD CC		Reference Value in Table 8.13.3.2.2-3
Symbols for unused PRBs			OCNG (Note 2)
Number of allocated resource blocks (Note 2)		PRB	50
Simultaneous transmission			No
PDSCH transmission mode			9
Note 1: $P_B = 1$			
Note 2: These physical resource blocks are assigned to an arbitrary number of virtual UEs with one PDSCH per virtual UE; the data transmitted over the OCNG PDSCHs shall be uncorrelated pseudo random data, which is QPSK modulated.			
Note 3: ACK/NACK bits are transmitted using PUSCH with PUCCH format 3.			

**Table 8.13.3.2.2-2: Single carrier performance with different bandwidths for multiple CA configurations for FDD SCell (FRC)**

Band - width	Reference channel		OCNG pattern	Propagation condition	Correlation matrix and antenna config.		Reference value		
	2Rx CC	4Rx CC			2Rx CC	4Rx CC	Fraction of maximum throughput (%)	SNR (dB)	
								2Rx CC	4Rx CC
5MHz	R.51-2 FDD	R.51-2 FDD	OP.1 FDD	ETU5	2x2 Low	2x4 Low	70	14.2	9.0
10 MHz	R.51 FDD	R.51 FDD	OP.1 FDD	ETU5	2x2 Low	2x4 Low	70	13.7	8.8
15M Hz	R.51-3 FDD	R.51-3 FDD	OP.1 FDD	ETU5	2x2 Low	2x4 Low	70	13.6	8.7
20M Hz	R.51-4 FDD	R.51-4 FDD	OP.1 FDD	ETU5	2x2 Low	2x4 Low	70	14.3	8.8
Note 1: The propagation conditions for Cell 1 and Cell 2 are statistically independent.									
Note 2: Correlation matrix and antenna configuration parameters apply for each of Cell 1 and Cell 2.									
Note 3: SNR corresponds to $\hat{E}_s / N_{oc}$ of Cell 1.									

**Table 8.13.3.2.2-3: Single carrier performance with different bandwidths for multiple CA configurations for TDD PCell and SCell (FRC)**

Band - width	Reference channel		OCNG pattern	Propagation condition	Correlation matrix and antenna config.		Reference value		
	2Rx CC	4Rx CC			2Rx CC	4Rx CC	Fraction of maximum throughput (%)	SNR (dB)	
								2Rx CC	4Rx CC
5MHz	R.51-2 TDD	R.51-2 TDD	OP.1 TDD	ETU5	2x2 Low	2x4 Low	70	14.0	9.0
10 MHz	R.51 TDD	R.51 TDD	OP.1 TDD	ETU5	2x2 Low	2x4 Low	70	13.9	9.1
15M Hz	R.51-3 TDD	R.51-3 TDD	OP.1 TDD	ETU5	2x2 Low	2x4 Low	70	13.9	9.2
20M Hz	R.51-4 TDD	R.51-4 TDD	OP.1 TDD	ETU5	2x2 Low	2x4 Low	70	14.1	9.3

Note 1: The propagation conditions for Cell 1 and Cell 2 are statistically independent.  
Note 2: Correlation matrix and antenna configuration parameters apply for each of Cell 1 and Cell 2.  
Note 3: SNR corresponds to  $\hat{E}_s/N_{oc}$  of Cell 1.

**Table 8.13.3.2.2-4: Minimum performance for multiple CA configurations with 2DL CCs (FRC)**

Test number	Aggregated Bandwidth (MHz)			Minimum performance requirement	UE Category
	Total	FDD CC	TDD CC		
1	2x20	20	20	As defined in Table 8.13.3.2.2-2 and Table 8.13.3.2.2-3 per CC	≥5
2	20+10	10	20	As defined in Table 8.13.3.2.2-2 and Table 8.13.3.2.2-3 per CC	≥5
3	20+15	15	20	As defined in Table 8.13.3.2.2-2 and Table 8.13.3.2.2-3 per CC	≥5

Note 1: The applicability of requirements for different CA configurations and bandwidth combination sets is defined in 8.1.2.6.

**Table 8.13.3.2.2-5: Minimum performance for multiple CA configurations with 3DL CCs (FRC)**

Test number	Aggregated Bandwidth (MHz)			Minimum performance requirement	UE Category
	Total	FDD CC	TDD CC		
1	3x20	20	2x20	As defined in Table 8.13.3.2.2-2 and Table 8.13.3.2.2-3 per CC	≥5
2	20+20+15	15	2x20	As defined in Table 8.13.3.2.2-2 and Table 8.13.3.2.2-3 per CC	≥5
3	20+20+10	10	2x20	As defined in Table 8.13.3.2.2-2 and Table 8.13.3.2.2-3 per CC	≥5
4	3x20	2x20	20	As defined in Table 8.13.3.2.2-2 and Table 8.13.3.2.2-3 per CC	≥5
5	20+20+15	20+15	20	As defined in Table 8.13.3.2.2-2 and Table 8.13.3.2.2-3 per CC	≥5
6	20+20+10	20+10	20	As defined in Table 8.13.3.2.2-2 and Table 8.13.3.2.2-3 per CC	≥5
7	20+10+10	2x10	20	As defined in Table 8.13.3.2.2-2 and Table 8.13.3.2.2-3 per CC	≥5
8	10+15+20	10	15+20	As defined in Table 8.13.3.2.1-2 and Table 8.13.3.2.1-3 per CC	≥5
9	10+15+20	10+15	20	As defined in Table 8.13.3.2.1-2 and Table 8.13.3.2.1-3 per CC	≥5

Note 1: The applicability of requirements for different CA configurations and bandwidth combination sets is defined in 8.1.2.6.

Table 8.13.3.2.2-6: Minimum performance for multiple CA configurations with 4DL CCs (FRC)

Test number	Aggregated Bandwidth (MHz)			Minimum performance requirement	UE Category
	Total	FDD CC	TDD CC		
1	4x20	20	3x20	As defined in Table 8.13.3.2.2-2 and Table 8.13.3.2.2-3 per CC	≥8
2	4x20	2x20	2x20	As defined in Table 8.13.3.2.2-2 and Table 8.13.3.2.2-3 per CC	≥8
3	3x20+15	20+15	2x20	As defined in Table 8.13.3.2.2-2 and Table 8.13.3.2.2-3 per CC	≥8
4	2x15+2x20	2x15	2x20	As defined in Table 8.13.3.2.2-2 and Table 8.13.3.2.2-3 per CC	≥8
5	3x20+15	2x20+15	20	As defined in Table 8.13.3.2.2-2 and Table 8.13.3.2.2-3 per CC	≥8
6	2x15+2x20	2x15+20	20	As defined in Table 8.13.3.2.2-2 and Table 8.13.3.2.2-3 per CC	≥8
7	3x20+10	2x20+10	20	As defined in Table 8.13.3.2.2-2 and Table 8.13.3.2.2-3 per CC	≥8
8	4x20	3x20	20	As defined in Table 8.13.3.1.2-2 and Table 8.13.3.1.2-3 per CC	≥8
9	10+3x20	10	3x20	As defined in Table 8.13.3.1.2-2 and Table 8.13.3.1.2-3 per CC	≥8
10	2x10+2x20	2x10	2x20	As defined in Table 8.13.3.1.2-2 and Table 8.13.3.1.2-3 per CC	≥8
11	2x10+20+15	2x10	20+15	As defined in Table 8.13.3.1.2-2 and Table 8.13.3.1.2-3 per CC	≥8
12	10+3x20	10+20	2x20	As defined in Table 8.13.3.1.2-2 and Table 8.13.3.1.2-3 per CC	≥8
13	10+15+2x20	10+15	2x20	As defined in Table 8.13.3.1.2-2 and Table 8.13.3.1.2-3 per CC	≥8
14	10+15+2x20	10+15+20	20	As defined in Table 8.13.3.1.2-2 and Table 8.13.3.1.2-3 per CC	≥8

Note 1: The applicability of requirements for different CA configurations and bandwidth combination sets is defined in 8.1.2.6.

Table 8.13.3.2.2-7: Minimum performance for multiple CA configurations with 5DL CCs (FRC)

Test number	Aggregated Bandwidth (MHz)			Minimum performance requirement	UE Category
	Total	FDD CC	TDD CC		
1	15+4x20	15+2x20	2x20	As defined in Table 8.13.3.2.2-2 and Table 8.13.3.2.2-3 per CC	8, ≥11
2	2x15+3x20	2x15+20	2x20	As defined in Table 8.13.3.2.2-2 and Table 8.13.3.2.2-3 per CC	8, ≥11
3	4x20+20	4x20	20	As defined in Table 8.13.3.2.2-2 and Table 8.13.3.2.2-3 per CC	8, ≥11
4	3x20+2x20	3x20	2x20	As defined in Table 8.13.3.2.2-2 and Table 8.13.3.2.2-3 per CC	8, ≥11
5	2x20+3x20	2x20	3x20	As defined in Table 8.13.3.2.2-2 and Table 8.13.3.2.2-3 per CC	8, ≥11
6	20+4x20	20	4x20	As defined in Table 8.13.3.2.2-2 and Table 8.13.3.2.2-3 per CC	8, ≥11
7	10+4x20	10	4x20	As defined in Table 8.13.3.2.2-2 and Table 8.13.3.2.2-3 per CC	8, ≥11
8	10+20+3x20	10+20	3x20	As defined in Table 8.13.3.2.2-2 and Table 8.13.3.2.2-3 per CC	8, ≥11
9	2x10+3x20	2x10	3x20	As defined in Table 8.13.3.2.2-2 and Table 8.13.3.2.2-3 per CC	8, ≥11
10	10+2x20+2x20	10+2x20	2x20	As defined in Table 8.13.3.2.2-2 and Table 8.13.3.2.2-3 per CC	8, ≥11
11	10+15+20+2x20	10+15+20	2x20	As defined in Table 8.13.3.2.2-2 and Table 8.13.3.2.2-3 per CC	8, ≥11

Note 1: The applicability of requirements for different CA configurations and bandwidth combination sets is defined in 8.1.2.6.

### 8.13.3.3 Enhanced Performance Requirements Type A Closed-loop spatial multiplexing

#### 8.13.3.3.1 Minimum Requirement Single-Layer Spatial Multiplexing 2 Tx Antenna Port with TM4 interference model (Cell-Specific Reference Symbols) for FDD PCell

The purpose of these tests is to verify the closed loop rank-one performance with wideband precoding with two transmit antennas when the PDSCH transmission in the serving cell is interfered by PDSCH of one dominant interfering cell applying transmission mode 4 interference model defined in clause B.5.3. In Table 8.13.3.3.1-1, Cell 1 is the serving cell, and Cell 2 is the interfering cell. The downlink physical channel setup is according to Annex C.3.2 for each of Cell 1 and Cell 2, respectively.

For TDD FDD CA with FDD PCell and with 2 DL CCs, the requirements are specified in Table 8.13.3.3.1-4, based on single carrier requirement specified in Table 8.13.3.3.1-2 and Table 8.13.3.3.1-3, with the addition of the parameters in Table 8.13.3.3.1-1 and the downlink physical channel setup according to Annex C.3.2.

**Table 8.13.3.3.1-1: Test Parameters for Single-Layer Spatial Multiplexing (FRC) with TM4 interference model for CA**

Parameter	Unit	Cell 1		Cell 2	
Downlink power allocation	$\rho_A$	dB	-3	-3	-3
	$\rho_B$	dB	-3 (Note 1)	-3	-3
	$\sigma$	dB	0	0	0
Cell-specific reference signals			Antenna ports 0,1	Antenna ports 0,1	
$N_{oc}$ at antenna port		dBm/15kHz	-98	N/A	
DIP (Note 2)		dB	N/A	-1.73	
Cell Id			0	1	
PDSCH transmission mode			6	4	
Interference model			N/A	As specified in clause B.5.3	
Probability of occurrence of transmission rank in interfering cells	Rank 1	%	N/A	80	
	Rank 2	%	N/A	20	
Precoding granularity		PRB	25 for 5MHz CCs, 50 for 10MHz CCs, 75 for 15MHz and 100 for 20MHz CCs	4 for 5MHz CCs, 6 for 10MHz CCs, 8 for 15MHz and 20MHz CCs	
PMI delay (Note 4)	FDD CC	ms	8	N/A	
	TDD CC	ms	10 or 11	N/A	
Reporting interval		ms	5	N/A	
Reporting mode			PUCCH 1-1	N/A	
CodeBookSubsetRestriction bitmap			1111	N/A	
Physical channel for CQI reporting			PUSCH (Note 7)	N/A	
cqi-pmi-ConfigurationIndex	FDD PCC		4	N/A	
	TDD SCC		5	N/A	

Note 1:  $P_B = 1$

Note 2: The respective received power spectral density of each interfering cell relative to  $N_{oc}$  is defined by its associated DIP value as specified in clause B.5.1.

Note 3: Cell 1 is the serving cell. Cell 2 is the interfering cell.

Note 4: If the UE reports in an available uplink reporting instance at subframe SF#n based on PMI estimation at a downlink SF not later than SF#(n-4), this reported PMI cannot be applied at the eNB downlink before SF#(n+4).

Note 5: All cells are time-synchronous.

Note 6: ACK/NACK bits are transmitted using PUSCH with PUCCH format 1b with channel selection configured for tests with 2 CCs.

Note 7: To avoid collisions between CQI reports and HARQ-ACK it is necessary to report both on PUSCH instead of PUCCH. PDCCH DCI format 0 shall be transmitted in downlink SF#4 and #9 to allow periodic CQI to multiplex with the HARQ-ACK on PUSCH in uplink subframe SF#8 and #3 for TDD CCs, and PDCCH DCI format 0 shall be transmitted in downlink SF#3 and #8 to allow periodic CQI to multiplex with the HARQ-ACK on PUSCH in uplink subframe SF#7 and #2 for FDD CCs.

**Table 8.13.3.3.1-2: Single carrier performance for Enhanced Performance Requirement Type A for FDD PCell and SCell (FRC)**

Bandwidth	Reference Channel		OCNG Pattern		Propagation Conditions		Correlation Matrix and Antenna Configuration (Note 3)		Reference Value				
	2Rx CC	4Rx CC	Cell 1	Cell 2	Cell 1	Cell 2	2Rx CC	4Rx CC	Fraction of Maximum Throughput (%)	SINR (dB) (Note 2)		2Rx CC	4Rx CC
										2Rx CC	4Rx CC		

5MHz	R.47-1 FDD	R.47-1 FDD	OP.1 FDD	N/A	EVA5	EVA5	2x2 Low	2x4 Low	70	0.8	-3.0
10 MHz	R.47 FDD	R.47 FDD	OP.1 FDD	N/A	EVA5	EVA5	2x2 Low	2x4 Low	70	1.0	-2.7
15MHz	R.47-2 FDD	R.47-2 FDD	OP.1 FDD	N/A	EVA5	EVA5	2x2 Low	2x4 Low	70	0.8	-2.9
20MHz	R.47-3 FDD	R.47-3 FDD	OP.1 FDD	N/A	EVA5	EVA5	2x2 Low	2x4 Low	70	1.1	-2.8
Note 1: The propagation conditions for Cell 1 and Cell 2 are statistically independent.											
Note 2: SINR corresponds to $E_s/N_{oc}$ of Cell 1 as defined in clause 8.1.1.											
Note 3: Correlation matrix and antenna configuration parameters apply for each of Cell 1 and Cell 2.											

**Table 8.13.3.3.1-3: Single carrier performance for Enhanced Performance Requirement Type A for TDD SCell (FRC)**

Band-width	Reference Channel		OCNG Pattern		Propagation Conditions		Correlation Matrix and Antenna Configuration (Note 3)		Reference Value		
	2Rx CC	4Rx CC	Cell 1	Cell 2	Cell 1	Cell 2	2Rx CC	4Rx CC	Fraction of Maximum Throughput (%)	SINR (dB) (Note 2)	
										2Rx CC	4Rx CC
5MHz	R.47-1 TDD	R.47-1 TDD	OP.1 TDD	N/A	EVA5	EVA5	2x2 Low	2x4 Low	70	0.8	-2.8
10 MHz	R.47 TDD	R.47 TDD	OP.1 TDD	N/A	EVA5	EVA5	2x2 Low	2x4 Low	70	1.3	-2.5
15MHz	R.47-2 TDD	R.47-2 TDD	OP.1 TDD	N/A	EVA5	EVA5	2x2 Low	2x4 Low	70	1.0	-2.7
20MHz	R.47-3 TDD	R.47-3 TDD	OP.1 TDD	N/A	EVA5	EVA5	2x2 Low	2x4 Low	70	1.3	-2.3
Note 1: The propagation conditions for Cell 1 and Cell 2 are statistically independent.											
Note 2: SINR corresponds to $E_s/N_{oc}$ of Cell 1 as defined in clause 8.1.1.											
Note 3: Correlation matrix and antenna configuration parameters apply for each of Cell 1 and Cell 2.											

**Table 8.13.3.3.1-4: Minimum performance for multiple CA configurations with 2DL CCs (FRC)**

Test number	Aggregated Bandwidth (MHz)			Minimum performance requirement	UE Category
	Total	FDD CC	TDD CC		
1	2x20	20	20	As defined in Table 8.13.3.3.1-2 and Table 8.13.3.3.1-3 per CC	≥5
2	20+10	10	20	As defined in Table 8.13.3.3.1-2 and Table 8.13.3.3.1-3 per CC	≥5
3	20+15	15	20	As defined in Table 8.13.3.3.1-2 and Table 8.13.3.3.1-3 per CC	≥5
Note 1: The applicability of requirements for different CA configurations and bandwidth combination sets is defined in 8.1.2.6.					

### 8.13.3.3.2 Minimum Requirement Single-Layer Spatial Multiplexing 2 Tx Antenna Port with TM4 interference model (Cell-Specific Reference Symbols) for TDD PCell

The purpose of these tests is to verify the closed loop rank-one performance with wideband precoding with two transmit antennas when the PDSCH transmission in the serving cell is interfered by PDSCH of one dominant interfering cell applying transmission mode 4 interference model defined in clause B.5.3. In Table 8.13.3.3.2-1, Cell 1 is the serving cell, and Cell 2 is the interfering cell. The downlink physical channel setup is according to Annex C.3.2 for each of Cell 1 and Cell 2, respectively.

For TDD FDD CA with TDD PCell with 2 DL CCs, the requirements are specified in Table 8.13.3.3.2-4, based on single carrier requirement specified in Table 8.13.3.3.2-2 and Table 8.13.3.3.2-3, with the addition of the parameters in Table 8.13.3.3.2-1 and the downlink physical channel setup according to Annex C.3.2.

**Table 8.13.3.3.2-1: Test Parameters for Single-Layer Spatial Multiplexing (FRC) with TM4 interference model for CA**

Parameter	Unit	Cell 1	Cell 2
Downlink power allocation	$\rho_A$	dB	-3
	$\rho_B$	dB	-3 (Note 1)
	$\sigma$	dB	0
Cell-specific reference signals		Antenna ports 0,1	Antenna ports 0,1
$N_{oc}$ at antenna port	dBm/15kHz	-98	N/A
DIP (Note 2)	dB	N/A	-1.73
Cell Id		0	1
PDSCH transmission mode		6	4
Interference model		N/A	As specified in clause B.5.3
Probability of occurrence of transmission rank in interfering cells	Rank 1	%	80
	Rank 2	%	20
Precoding granularity	PRB	25 for 5MHz CCs, 50 for 10MHz CCs, 75 for 15MHz and 100 for 20MHz CCs	4 for 5MHz CCs, 6 for 10MHz CCs, 8 for 15MHz and 20MHz CCs
PMI delay (Note 4)	FDD CC	ms	8
	TDD CC	ms	10 or 11
Reporting interval		ms	5
Reporting mode			PUCCH 1-1
CodeBookSubsetRestriction bitmap			1111

Note 1:  $\rho_B = 1$

Note 2: The respective received power spectral density of each interfering cell relative to  $N_{oc}$  is defined by its associated DIP value as specified in clause B.5.1.

Note 3: Cell 1 is the serving cell. Cell 2 is the interfering cell.

Note 4: If the UE reports in an available uplink reporting instance at subframe SF#n based on PMI estimation at a downlink SF not later than SF#(n-4), this reported PMI cannot be applied at the eNB downlink before SF#(n+4).

Note 5: All cells are time-synchronous.

Note 6: ACK/NACK bits are transmitted using PUSCH with PUCCH format 1b with channel selection configured for tests with 2 CCs.

**Table 8.13.3.3.2-2: Single carrier performance for Enhanced Performance Requirement Type A for FDD SCell (FRC)**

Bandwidth	Reference Channel		OCNG Pattern		Propagation Conditions		Correlation Matrix and Antenna Configuration (Note 3)		Reference Value		
	2Rx CC	4Rx CC	Cell 1	Cell 2	Cell 1	Cell 2	2Rx CC	4Rx CC	Fraction of Maximum Throughput (%)	SINR (dB) (Note 2)	
										2Rx CC	4Rx CC



5MHz	R.47-1 FDD	R.47-1 FDD	OP.1 FDD	N/A	EVA5	EVA5	2x2 Low	2x4 Low	70	0.8	-3.0
10 MHz	R.47 FDD	R.47 FDD	OP.1 FDD	N/A	EVA5	EVA5	2x2 Low	2x4 Low	70	1.0	-2.7
15MHz	R.47-2 FDD	R.47-2 FDD	OP.1 FDD	N/A	EVA5	EVA5	2x2 Low	2x4 Low	70	0.8	-2.9
20MHz	R.47-3 FDD	R.47-3 FDD	OP.1 FDD	N/A	EVA5	EVA5	2x2 Low	2x4 Low	70	1.1	-2.8
Note 1: The propagation conditions for Cell 1 and Cell 2 are statistically independent.											
Note 2: SINR corresponds to $E_s/N_{oc}$ of Cell 1 as defined in clause 8.1.1.											
Note 3: Correlation matrix and antenna configuration parameters apply for each of Cell 1 and Cell 2.											

**Table 8.13.3.3.2-3: Single carrier performance for Enhanced Performance Requirement Type A for TDD PCell and SCell (FRC)**

Band-width	Reference Channel		OCNG Pattern		Propagation Conditions		Correlation Matrix and Antenna Configuration (Note 3)		Reference Value		
	2Rx CC	4Rx CC	Cell 1	Cell 2	Cell 1	Cell 2	2Rx CC	4Rx CC	Fraction of Maximum Throughput (%)	SINR (dB) (Note 2)	
										2Rx CC	4Rx CC
5MHz	R.47-1 TDD	R.47-1 TDD	OP.1 TDD	N/A	EVA5	EVA5	2x2 Low	2x4 Low	70	0.8	-2.8
10 MHz	R.47 TDD	R.47 TDD	OP.1 TDD	N/A	EVA5	EVA5	2x2 Low	2x4 Low	70	1.3	-2.5
15MHz	R.47-2 TDD	R.47-2 TDD	OP.1 TDD	N/A	EVA5	EVA5	2x2 Low	2x4 Low	70	1.0	-2.7
20MHz	R.47-3 TDD	R.47-3 TDD	OP.1 TDD	N/A	EVA5	EVA5	2x2 Low	2x4 Low	70	1.3	-2.3
Note 1: The propagation conditions for Cell 1 and Cell 2 are statistically independent.											
Note 2: SINR corresponds to $E_s/N_{oc}$ of Cell 1 as defined in clause 8.1.1.											
Note 3: Correlation matrix and antenna configuration parameters apply for each of Cell 1 and Cell 2.											

**Table 8.13.3.3.2-4: Minimum performance for multiple CA configurations with 2DL CCs (FRC)**

Test number	Aggregated Bandwidth (MHz)			Minimum performance requirement	UE Category
	Total	FDD CC	TDD CC		
1	2x20	20	20	As defined in Table 8.13.3.3.2-2 and Table 8.13.3.3.2-3 per CC	≥5
2	20+10	10	20	As defined in Table 8.13.3.3.2-2 and Table 8.13.3.3.2-3 per CC	≥5
3	20+15	15	20	As defined in Table 8.13.3.3.2-2 and Table 8.13.3.3.2-3 per CC	≥5
Note 1: The applicability of requirements for different CA configurations and bandwidth combination sets is defined in 8.1.2.6					

### 8.13.3.4 Enhanced Performance Requirement Type A - Single-layer Spatial Multiplexing (User-Specific Reference Symbols)

#### 8.13.3.4.1 Minimum Requirement Enhanced Performance Requirement Type A – Single-layer Spatial Multiplexing with TM9 interference model (User-Specific Reference Symbols) for FDD PCell

The purpose of these tests is to verify closed loop rank one performance on one of the antenna ports 7 or 8 without a simultaneous transmission on the other antenna port in the serving cell when the PDSCH transmission in the serving cell is interfered by PDSCH of one dominant interfering cell applying transmission mode 9 interference model defined

in clause B.5.4. In 8.13.3.4.1-1, Cell 1 is the serving cell, and Cell 2 is the interfering cell. The downlink physical channel setup is according to Annex C.3.2 for each of Cell 1 and Cell 2, respectively.

For TDD FDD CA with FDD PCell with 2 DL CCs, the requirements are specified in Table 8.13.3.4.1-4, based on single carrier requirement specified in Table 8.13.3.4.1-2 and Table 8.13.3.4.1-3, with the addition of the parameters in Table 8.13.3.4.1-1 and the downlink physical channel setup according to Annex C.3.2.

**Table 8.13.3.4.1-1: Test Parameters for Testing CDM-multiplexed DM RS (single layer) with TM9 interference model for CA**

parameter		Unit	Cell 1	Cell 2
Downlink power allocation	$\rho_A$	dB	0	0
	$\rho_B$	dB	0 (Note 1)	0
	$\sigma$	dB	-3	-3
Cell-specific reference signals			Antenna ports 0,1	Antenna ports 0,1
CSI reference signals			Antenna ports 15,16	N/A
CSI-RS periodicity and subframe offset $T_{\text{CSI-RS}} / \Delta_{\text{CSI-RS}}$	FDD CC	Subframes	5 / 2	N/A
	TDD CC		5 / 4	N/A
CSI reference signal configuration			0	N/A
$N_{oc}$ at antenna port $z$		dBm/15kHz	-98	N/A
DIP (Note 2)		dB	N/A	-1.73
Cell Id			0	126
PDSCH transmission mode			9	9
Beamforming model			As specified in clause B.4.3 (Note 4, 5)	N/A
Interference model			N/A	As specified in clause B.5.4
Probability of occurrence of transmission rank in interfering cells	Rank 1		N/A	70
	Rank 2		N/A	30

Precoder update granularity		PRB	25 for 5MHz CCs, 50 for 10MHz CCs, 75 for 15MHz and 100 for 20MHz CCs	4 for 5MHz CCs, 6 for 10MHz CCs, 8 for 15MHz and 20MHz CCs
PMI delay (Note 5)	FDD CC	Ms	8	N/A
	TDD CC		10 or 11	N/A
Reporting interval		Ms	5	N/A
Reporting mode			PUCCH 1-1	N/A
CodeBookSubsetRestriction bitmap			001111	N/A
Symbols for unused PRBs			OCNG (Note 6)	N/A
Simultaneous transmission			No simultaneous transmission on the other antenna port in (7 or 8) used for the input signal under test	N/A
Physical channel for CQI reporting			PUSCH(Note 8)	N/A
cqi-pmi-ConfigurationIndex	FDD PCC		4	N/A
	TDD SCC		5	N/A
<p>Note 1: <math>P_B = 1</math></p> <p>Note 2: The respective received power spectral density of each interfering cell relative to <math>N_{oc}</math> is defined by its associated DIP value as specified in clause B.5.1.</p> <p>Note 3: The modulation symbols of the signal under test in Cell 1 are mapped onto antenna port 7 or 8.</p> <p>Note 4: The precoder in clause B.4.3 follows UE recommended PMI.</p> <p>Note 5: If the UE reports in an available uplink reporting instance at subframe SF#n based on PMI estimation at a downlink SF not later than SF#(n-4), this reported PMI cannot be applied at the eNB downlink before SF#(n+4).</p> <p>Note 6: These physical resource blocks are assigned to an arbitrary number of virtual UEs with one PDSCH per virtual UE; the data transmitted over the OCNG PDSCHs shall be uncorrelated pseudo random data, which is QPSK modulated.</p> <p>Note 7: All cells are time-synchronous.</p> <p>Note 8: To avoid collisions between CQI reports and HARQ-ACK it is necessary to report both on PUSCH instead of PUCCH. PDCCCH DCI format 0 shall be transmitted in downlink SF#4 and #9 to allow periodic CQI to multiplex with the HARQ-ACK on PUSCH in uplink subframe SF#8 and #3 for TDD CCs, and PDCCCH DCI format 0 shall be transmitted in downlink SF#3 and #8 to allow periodic CQI to multiplex with the HARQ-ACK on PUSCH in uplink subframe SF#7 and #2 for FDD CCs.</p> <p>Note 9: ACK/NACK bits are transmitted using PUSCH with PUCCH format 1b with channel selection configured for tests with 2 CCs.</p>				

**Table 8.13.3.4.1-2: Single carrier performance for Enhanced Performance Requirement Type A, CDM-multiplexed DM RS for FDD PCell (FRC)**

Bandwidth	Reference Channel		OCNG Pattern		Propagation Conditions		Correlation Matrix and Antenna Configuration (Note 3)		Reference Value		
	2Rx CC	4Rx CC	Cell 1	Cell 2	Cell 1	Cell 2	2Rx CC	4Rx CC	Fraction of Maximum Throughput (%)	SINR (dB) (Note 2)	
										2Rx CC	4Rx CC

5MHz	R.76-1 FDD	R.76-4 FDD	OP.1 FDD	N/A	EVA5	EVA5	2x2 Low	2x4 Low	70	-0.4	-2.0
10 MHz	R.76 FDD	R.76-5 FDD	OP.1 FDD	N/A	EVA5	EVA5	2x2 Low	2x4 Low	70	0.1	-1.8
15MHz	R.76-2 FDD	R.76-6 FDD	OP.1 FDD	N/A	EVA5	EVA5	2x2 Low	2x4 Low	70	-0.2	-1.9
20MHz	R.76-3 FDD	R.76-7 FDD	OP.1 FDD	N/A	EVA5	EVA5	2x2 Low	2x4 Low	70	-0.4	-1.7

Note 1: The propagation conditions for Cell 1 and Cell 2 are statistically independent.

Note 2: SINR corresponds to  $E_s/N_{oc}$  of Cell 1 as defined in clause 8.1.1.

Note 3: Correlation matrix and antenna configuration parameters apply for each of Cell 1 and Cell 2.

**Table 8.13.3.4.1-3: Single carrier performance for Enhanced Performance Requirement Type A, CDM-multiplexed DM RS for TDD SCell (FRC)**

Bandwidth	Reference Channel		OCNG Pattern		Propagation Conditions		Correlation Matrix and Antenna Configuration (Note 3)		Reference Value		
	2Rx CC	4Rx CC	Cell 1	Cell 2	Cell 1	Cell 2	2Rx CC	4Rx CC	Fraction of Maximum Throughput (%)	SINR (dB) (Note 2)	
										2Rx CC	4Rx CC
5MHz	R.76-1 TDD	R.76-4 TDD	OP.1 TDD	N/A	EVA5	EVA5	2x2 Low	2x4 Low	70	-0.6	-2.4
10 MHz	R.76 TDD	R.76-5 TDD	OP.1 TDD	N/A	EVA5	EVA5	2x2 Low	2x4 Low	70	-0.1	-2.1
15MHz	R.76-2 TDD	R.76-6 TDD	OP.1 TDD	N/A	EVA5	EVA5	2x2 Low	2x4 Low	70	-0.2	-2.1
20MHz	R.76-3 TDD	R.76-7 TDD	OP.1 TDD	N/A	EVA5	EVA5	2x2 Low	2x4 Low	70	-0.4	-2.1

Note 1: The propagation conditions for Cell 1 and Cell 2 are statistically independent.

Note 2: SINR corresponds to  $E_s/N_{oc}$  of Cell 1 as defined in clause 8.1.1.

Note 3: Correlation matrix and antenna configuration parameters apply for each of Cell 1 and Cell 2.

**Table 8.13.3.4.1-4: Minimum performance (FRC) based on single carrier performance for CA with 2 DL CCs**

Test number	Aggregated Bandwidth (MHz)			Minimum performance requirement	UE Category
	Total	FDD CC	TDD CC		
1	2x20	20	20	As defined in Table 8.13.3.4.1-2 and Table 8.13.3.4.1-3 per CC	≥5
2	20+10	10	20	As defined in Table 8.13.3.4.1-2 and Table 8.13.3.4.1-3 per CC	≥5
3	20+15	15	20	As defined in Table 8.13.3.4.1-2 and Table 8.13.3.4.1-3 per CC	≥5

Note 1: The applicability of requirements for different CA configurations and bandwidth combination sets is defined in 8.1.2.6.

#### 8.13.3.4.2 Minimum Requirement Enhanced Performance Requirement Type A – Single-layer Spatial Multiplexing with TM9 interference model (User-Specific Reference Symbols) for TDD PCell

The purpose of these tests is to verify closed loop rank one performance on one of the antenna ports 7 or 8 without a simultaneous transmission on the other antenna port in the serving cell when the PDSCH transmission in the serving cell is interfered by PDSCH of one dominant interfering cell applying transmission mode 9 interference model defined in clause B.5.4. In 8.13.3.4.2-1, Cell 1 is the serving cell, and Cell 2 is the interfering cell. The downlink physical channel setup is according to Annex C.3.2 for each of Cell 1 and Cell 2, respectively.

For TDD FDD CA with TDD PCell with 2 DL CCs, the requirements are specified in Table 8.13.3.4.2-4, based on single carrier requirement specified in Table 8.13.3.4.2-2 and Table 8.13.3.4.2-3, with the addition of the parameters in Table 8.13.3.4.2-1 and the downlink physical channel setup according to Annex C.3.2.

**Table 8.13.3.4.2-1: Test Parameters for Testing CDM-multiplexed DM RS (single layer) with TM9 interference model for CA**

parameter		Unit	Cell 1	Cell 2
Downlink power allocation	$\rho_A$	dB	0	0
	$\rho_B$	dB	0 (Note 1)	0
	$\sigma$	dB	-3	-3
Cell-specific reference signals			Antenna ports 0,1	Antenna ports 0,1
CSI reference signals			Antenna ports 15,16	N/A
CSI-RS periodicity and subframe offset $T_{\text{CSI-RS}} / \Delta_{\text{CSI-RS}}$	FDD CC	Subframes	5 / 2	N/A
	TDD CC		5 / 4	N/A
CSI reference signal configuration			0	N/A
$N_{oc}$ at antenna port		dBm/15kHz	-98	N/A
DIP (Note 2)		dB	N/A	-1.73
Cell Id			0	126
PDSCH transmission mode			9	9
Beamforming model			As specified in clause B.4.3 (Note 4, 5)	N/A
Interference model			N/A	As specified in clause B.5.4
Probability of occurrence of transmission rank in interfering cells	Rank 1		N/A	70
	Rank 2		N/A	30

Precoder update granularity		PRB	25 for 5MHz CCs, 50 for 10MHz CCs, 75 for 15MHz and 100 for 20MHz CCs	4 for 5MHz CCs, 6 for 10MHz CCs, 8 for 15MHz and 20MHz CCs
PMI delay (Note 5)	FDD CC	Ms	8	N/A
	TDD CC		10 or 11	N/A
Reporting interval		Ms	5	N/A
Reporting mode			PUCCH 1-1	N/A
CodeBookSubsetRestriction bitmap			001111	N/A
Symbols for unused PRBs			OCNG (Note 6)	N/A
Simultaneous transmission			No simultaneous transmission on the other antenna port in (7 or 8) used for the input signal under test	N/A
Physical channel for CQI reporting			PUSCH(Note 8)	N/A
cqi-pmi-ConfigurationIndex	FDD CC		3	N/A
	TDD CC		4	N/A
<p>Note 1: <math>P_B = 1</math></p> <p>Note 2: The respective received power spectral density of each interfering cell relative to <math>N_{oc}</math> is defined by its associated DIP value as specified in clause B.5.1.</p> <p>Note 3: The modulation symbols of the signal under test in Cell 1 are mapped onto antenna port 7 or 8.</p> <p>Note 4: The precoder in clause B.4.3 follows UE recommended PMI.</p> <p>Note 5: If the UE reports in an available uplink reporting instance at subframe SF#n based on PMI estimation at a downlink SF not later than SF#(n-4), this reported PMI cannot be applied at the eNB downlink before SF#(n+4).</p> <p>Note 6: These physical resource blocks are assigned to an arbitrary number of virtual UEs with one PDSCH per virtual UE; the data transmitted over the OCNG PDSCHs shall be uncorrelated pseudo random data, which is QPSK modulated.</p> <p>Note 7: All cells are time-synchronous.</p> <p>Note 8: To avoid collisions between CQI reports and HARQ-ACK it is necessary to report both on PUSCH instead of PUCCH. PDCCCH DCI format 0 shall be transmitted in downlink SF#4 and #9 to allow periodic CQI to multiplex with the HARQ-ACK on PUSCH in uplink subframe SF#8 and #3 for TDD CCs, and PDCCCH DCI format 0 shall be transmitted in downlink SF#3 and #8 to allow periodic CQI to multiplex with the HARQ-ACK on PUSCH in uplink subframe SF#7 and #2 for FDD CCs.</p> <p>Note 9: ACK/NACK bits are transmitted using PUSCH with PUCCH format 1b with channel selection configured for tests with 2 CCs.</p>				

**Table 8.13.3.4.2-2: Single carrier performance for Enhanced Performance Requirement Type A, CDM-multiplexed DM RS for FDD SCell (FRC)**

Bandwidth	Reference Channel		OCNG Pattern		Propagation Conditions		Correlation Matrix and Antenna Configuration (Note 3)		Reference Value		
	2Rx CC	4Rx CC	Cell 1	Cell 2	Cell 1	Cell 2	2Rx CC	4Rx CC	Fraction of Maximum Throughput (%)	SINR (dB) (Note 2)	
										2Rx CC	4Rx CC

5MHz	R.76-1 FDD	R.76-4 FDD	OP.1 FDD	N/A	EVA5	EVA5	2x2 Low	2x4 Low	70	-0.4	-2.0
10 MHz	R.76 FDD	R.76-5 FDD	OP.1 FDD	N/A	EVA5	EVA5	2x2 Low	2x4 Low	70	0.1	-1.8
15MHz	R.76-2 FDD	R.76-6 FDD	OP.1 FDD	N/A	EVA5	EVA5	2x2 Low	2x4 Low	70	-0.2	-1.9
20MHz	R.76-3 FDD	R.76-7 FDD	OP.1 FDD	N/A	EVA5	EVA5	2x2 Low	2x4 Low	70	-0.4	-1.7

Note 1: The propagation conditions for Cell 1 and Cell 2 are statistically independent.

Note 2: SINR corresponds to  $E_s/N_{oc}$  of Cell 1 as defined in clause 8.1.1.

Note 3: Correlation matrix and antenna configuration parameters apply for each of Cell 1 and Cell 2.

**Table 8.13.3.4.2-3: Single carrier performance for Enhanced Performance Requirement Type A, CDM-multiplexed DM RS for TDD PCell (FRC)**

Band-width	Reference Channel		OCNG Pattern		Propagation Conditions		Correlation Matrix and Antenna Configuration (Note 3)		Reference Value		
	2Rx CC	4Rx CC	Cell 1	Cell 2	Cell 1	Cell 2	2Rx CC	4Rx CC	Fraction of Maximum Throughput (%)	SINR (dB) (Note 2)	
										2Rx CC	4Rx CC
5MHz	R.76-1 TDD	R.76-4 TDD	OP.1 TDD	N/A	EVA5	EVA5	2x2 Low	2x4 Low	70	-0.6	-2.4
10 MHz	R.76 TDD	R.76-5 TDD	OP.1 TDD	N/A	EVA5	EVA5	2x2 Low	2x4 Low	70	-0.1	-2.1
15MHz	R.76-2 TDD	R.76-6 TDD	OP.1 TDD	N/A	EVA5	EVA5	2x2 Low	2x4 Low	70	-0.2	-2.1
20MHz	R.76-3 TDD	R.76-7 TDD	OP.1 TDD	N/A	EVA5	EVA5	2x2 Low	2x4 Low	70	-0.4	-2.1

Note 1: The propagation conditions for Cell 1 and Cell 2 are statistically independent.

Note 2: SINR corresponds to  $E_s/N_{oc}$  of Cell 1 as defined in clause 8.1.1.

Note 3: Correlation matrix and antenna configuration parameters apply for each of Cell 1 and Cell 2.

**Table 8.13.3.4.2-4: Minimum performance (FRC) based on single carrier performance for CA with 2 DL CCs**

Test number	Aggregated Bandwidth (MHz)			Minimum performance requirement	UE Category
	Total	FDD CC	TDD CC		
1	2x20	20	20	As defined in Table 8.13.3.4.2-2 and Table 8.13.3.4.2-3 per CC	≥5
2	20+10	10	20	As defined in Table 8.13.3.4.2-2 and Table 8.13.3.4.2-3 per CC	≥5
3	20+15	15	20	As defined in Table 8.13.3.4.2-2 and Table 8.13.3.4.2-3 per CC	≥5

Note 1: The applicability of requirements for different CA configurations and bandwidth combination sets is defined in 8.1.2.6.

### 8.13.3.5 Closed-loop spatial multiplexing performance 4Tx Antenna Port for DC

#### 8.13.3.5.1 Minimum Requirement for FDD PCell

The purpose of these tests is to verify the closed loop rank-two performance with wideband and frequency selective precoding.

For TDD FDD DC with FDD PCell and 2DL CCs, the requirements are specified in Table 8.13.3.5.1-4 based on single carrier requirement specified in Table 8.13.3.5.1-2 and Table 8.13.3.5.1-3, with the addition of the parameters in Table 8.13.3.5.1-1 and the downlink physical channel setup according to Annex C.3.2.

The test coverage for different number of component carriers is defined in 8.1.2.4.

**Table 8.13.3.5.1-1: Test Parameters for Multi-Layer Spatial Multiplexing (FRC) for DC**

Parameter		Unit	Value
Downlink power allocation	$\rho_A$	dB	-6
	$\rho_B$	dB	-6 (Note 1)
	$\sigma$	dB	3
$N_{oc}$ at antenna port		dBm/15kHz	-98
Precoding granularity		PRB	Wideband precoding for 1.4MHz, 4 for 3MHz and 5MHz CCs, 6 for 10MHz CCs, 8 for 15MHz and 20MHz CCs
PMI delay (Note 2)	FDD CC	ms	8
	TDD CC	ms	10 or 11
Reporting interval	FDD CC	ms	1
	TDD CC	ms	1 or 4 (Note 3)
Reporting mode			PUSCH 1-2
CodeBookSubsetRestriction bitmap			00011111111111111111000000000000000000
CSI request field (Note 3)			'10'
PDSCH transmission mode			4
ACK/NACK transmission			Separate ACK/NACK feedbacks with PUCCH format 1b on the MCG and SCG
CSI feedback			Separate PUSCH feedbacks on the MCG and SCG
Time offset between MCG CC and SCG CC		$\mu$ s	0 for UE under test supporting synchronous dual connectivity; 334 for UE under test supporting both asynchronous and synchronous dual connectivity (Note 6)
<p>Note 1: <math>P_B = 1</math>.</p> <p>Note 2: If the UE reports in an available uplink reporting instance at subframe SF#n based on PMI estimation at a downlink SF not later than SF#(n-4), this reported PMI cannot be applied at the eNB downlink before SF#(n+4).</p> <p>Note 3: Multiple CC-s under test are configured as the 1<sup>st</sup> set of serving cells by higher layers.</p> <p>Note 4: ACK/NACK bits are transmitted using PUSCH with PUCCH format 3.</p> <p>Note 5: The same PDSCH transmission mode is applied to each component carrier.</p> <p>Note 6: As defined in TS36.300 [11].</p> <p>Note 7: If the UE supports both SCG bearer and Split bearer, the SCG bearer is configured.</p>			



**Table 8.13.3.5.1-2: Single carrier performance with different bandwidths for multiple DC configurations for FDD PCell and SCell (FRC)**

Band - width	Reference channel		OCNG pattern	Propagation condition	Correlation matrix and antenna config.		Reference value		
	2Rx CC	4Rx CC			2Rx CC	4Rx CC	Fraction of maximum throughput (%)	SNR (dB)	
								2Rx CC	4Rx CC
1.4M Hz	R.14-4 FDD	R.14-4 FDD	OP.1 FDD	EVA5	4x2 Low	4x4 Low	70	10.4	7.5
3MHz	R.14-5 FDD	R.14-5 FDD	OP.1 FDD	EVA5	4x2 Low	4x4 Low	70	9.5	5.1
5MHz	R.14-6 FDD	R.14-6 FDD	OP.1 FDD	EVA5	4x2 Low	4x4 Low	70	9.5	5.2
10 MHz	R.14 FDD	R.14 FDD	OP.1 FDD	EVA5	4x2 Low	4x4 Low	70	10.1	5.7
15M Hz	R.14-7 FDD	R.14-7 FDD	OP.1 FDD	EVA5	4x2 Low	4x4 Low	70	10.1	5.6
20M Hz	R.14-3 FDD	R.14-3 FDD	OP.1 FDD	EVA5	4x2 Low	4x4 Low	70	10.3	5.6

**Table 8.13.3.5.1-3: Single carrier performance with different bandwidths for multiple DC configurations for TDD SCell (FRC)**

Band - width	Reference channel		OCNG pattern	Propagation condition	Correlation matrix and antenna config.		Reference value		
	2Rx CC	4Rx CC			2Rx CC	4Rx CC	Fraction of maximum throughput (%)	SNR (dB)	
								2Rx CC	4Rx CC
1.4M Hz	R.43-1 TDD	R.43-1 TDD	OP.1 TDD	EVA5	4x2 Low	4x4 Low	70	11.0	8.1
3MHz	R.43-2 TDD	R.43-2 TDD	OP.1 TDD	EVA5	4x2 Low	4x4 Low	70	9.8	5.4
5MHz	R.43-3 TDD	R.43-3 TDD	OP.1 TDD	EVA5	4x2 Low	4x4 Low	70	10.0	5.9
10 MHz	R.43-4 TDD	R.43-4 TDD	OP.1 TDD	EVA5	4x2 Low	4x4 Low	70	10.5	6.3
15M Hz	R.43-5 TDD	R.43-5 TDD	OP.1 TDD	EVA5	4x2 Low	4x4 Low	70	10.6	6.2
20M Hz	R.43 TDD	R.43 TDD	OP.1 TDD	EVA5	4x2 Low	4x4 Low	70	10.7	6.4

**Table 8.13.3.5.1-4: Minimum performance for multiple DC configurations with 2DL CCs (FRC)**

Test number	Aggregated Bandwidth (MHz)			Minimum performance requirement	UE Category
	Total	FDD CC	TDD CC		
1	2x20	20	20	As defined in Table 8.13.3.5.1-2 and Table 8.13.3.5.1-3 per CC	≥5
Note 1:	The applicability of requirements for different CA configurations and bandwidth combination sets is defined in 8.1.2.6.				

### 8.13.3.5.2 Minimum Requirement for TDD PCell

The purpose of these tests is to verify the closed loop rank-two performance with wideband and frequency selective precoding.

For TDD FDD DC with TDD PCell and 2DL CCs, the requirements are specified in Table 8.13.3.5.2-4 based on single carrier requirement specified in Table 8.13.3.5.2-2 and Table 8.13.3.5.2-3, with the addition of the parameters in Table 8.13.3.5.2-1 and the downlink physical channel setup according to Annex C.3.2.

The test coverage for different number of component carriers is defined in 8.1.2.4.

Table 8.13.3.5.2-1: Test Parameters for Multi-Layer Spatial Multiplexing (FRC) for DC

Parameter		Unit	Value
Downlink power allocation	$\rho_A$	dB	-6
	$\rho_B$	dB	-6 (Note 1)
	$\sigma$	dB	3
$N_{oc}$ at antenna port		dBm/15kHz	-98
Precoding granularity		PRB	Wideband precoding for 1.4MHz, 4 for 3MHz and 5MHz CCs, 6 for 10MHz CCs, 8 for 15MHz and 20MHz CCs
PMI delay (Note 2)	FDD CC	ms	8
	TDD CC	ms	10 or 11
Reporting interval	FDD CC	ms	1
	TDD CC	ms	1 or 4 (Note 3)
Reporting mode			PUSCH 1-2
CodeBookSubsetRestriction bitmap			001111 11111111111100000000000000000000
CSI request field (Note 3)			'10'
PDSCH transmission mode			4
ACK/NACK transmission			Separate ACK/NACK feedbacks with PUCCH format 1b on the MCG and SCG
CSI feedback			Separate PUSCH feedbacks on the MCG and SCG
Time offset between MCG CC and SCG CC		$\mu\text{s}$	0 for UE under test supporting synchronous dual connectivity; 334 for UE under test supporting both asynchronous and synchronous dual connectivity (Note 6)
<p>Note 1: <math>P_{\beta} = 1</math>.</p> <p>Note 2: If the UE reports in an available uplink reporting instance at subframe SF#n based on PMI estimation at a downlink SF not later than SF#(n-4), this reported PMI cannot be applied at the eNB downlink before SF#(n+4).</p> <p>Note 3: Multiple CC-s under test are configured as the 1<sup>st</sup> set of serving cells by higher layers.</p> <p>Note 4: ACK/NACK bits are transmitted using PUSCH with PUCCH format 3.</p> <p>Note 5: The same PDSCH transmission mode is applied to each component carrier.</p> <p>Note 6: As defined in TS36.300 [11].</p> <p>Note 7: If the UE supports both SCG bearer and Split bearer, the SCG bearer is configured.</p>			

Table 8.13.3.5.2-2: Single carrier performance with different bandwidths for multiple DC configurations for FDD SCell (FRC)

Band - width	Reference channel		OCNG pattern	Propagation condition	Correlation matrix and antenna config.		Reference value		
	2Rx CC	4Rx CC			2Rx CC	4Rx CC	Fraction of maximum throughput (%)	SNR (dB)	
								2Rx CC	4Rx CC
1.4M Hz	R.14-4 FDD	R.14-4 FDD	OP.1 FDD	EVA5	4x2 Low	4x4 Low	70	10.4	7.5
3MHz	R.14-5 FDD	R.14-5 FDD	OP.1 FDD	EVA5	4x2 Low	4x4 Low	70	9.5	5.1
5MHz	R.14-6 FDD	R.14-6 FDD	OP.1 FDD	EVA5	4x2 Low	4x4 Low	70	9.5	5.2
10 MHz	R.14 FDD	R.14 FDD	OP.1 FDD	EVA5	4x2 Low	4x4 Low	70	10.1	5.7
15M Hz	R.14-7 FDD	R.14-7 FDD	OP.1 FDD	EVA5	4x2 Low	4x4 Low	70	10.1	5.6
20M Hz	R.14-3 FDD	R.14-3 FDD	OP.1 FDD	EVA5	4x2 Low	4x4 Low	70	10.3	5.6

**Table 8.13.3.5.2-3: Single carrier performance with different bandwidths for multiple DC configurations for TDD PCell and SCell (FRC)**

Band - width	Reference channel		OCNG pattern	Propagation condition	Correlation matrix and antenna config.		Reference value		
	2Rx CC	4Rx CC			2Rx CC	4Rx CC	Fraction of maximum throughput (%)	SNR (dB)	
								2Rx CC	4Rx CC
1.4M Hz	R.43-1 TDD	R.43-1 TDD	OP.1 TDD	EVA5	4x2 Low	4x4 Low	70	11.0	8.1
3MHz	R.43-2 TDD	R.43-2 TDD	OP.1 TDD	EVA5	4x2 Low	4x4 Low	70	9.8	5.4
5MHz	R.43-3 TDD	R.43-3 TDD	OP.1 TDD	EVA5	4x2 Low	4x4 Low	70	10.0	5.9
10 MHz	R.43-4 TDD	R.43-4 TDD	OP.1 TDD	EVA5	4x2 Low	4x4 Low	70	10.5	6.3
15M Hz	R.43-5 TDD	R.43-5 TDD	OP.1 TDD	EVA5	4x2 Low	4x4 Low	70	10.6	6.2
20M Hz	R.43 TDD	R.43 TDD	OP.1 TDD	EVA5	4x2 Low	4x4 Low	70	10.7	6.4

**Table 8.13.3.5.2-4: Minimum performance for multiple DC configurations with 2DL CCs (FRC)**

Test number	Aggregated Bandwidth (MHz)			Minimum performance requirement	UE Category
	Total	FDD CC	TDD CC		
1	2x20	20	20	As defined in Table 8.13.3.5.2-2 and Table 8.13.3.5.2-3 per CC	≥5
Note 1: The applicability of requirements for different CA configurations and bandwidth combination sets is defined in 8.1.2.6.					

### 8.13.3.6 Closed-loop spatial multiplexing performance 4Tx Antenna Port with 256QAM

#### 8.13.3.6.1 Minimum Requirement for FDD PCell

The purpose of these tests is to verify the closed loop rank-two performance with wideband and frequency selective precoding.

For TDD FDD CA with FDD PCell and 2DL CCs, the requirements are specified in Table 8.13.3.6.1-4 based on single carrier requirement specified in Table 8.13.3.6.1-2 and Table 8.13.3.6.1-3, with the addition of the parameters in Table 8.13.3.6.1-1 and the downlink physical channel setup according to Annex C.3.2.

The test coverage for different number of component carriers is defined in 8.1.2.4.

**Table 8.13.3.6.1-1: Test Parameters for Multi-Layer Spatial Multiplexing (FRC) for CA**

Parameter	Unit	Value
Downlink power allocation	$\rho_A$	dB
	$\rho_B$	dB
	$\sigma$	dB
$N_{oc}$ at antenna port	dBm/15kHz	-98
Precoding granularity	PRB	Wideband precoding for 1.4MHz, 4 for 3MHz and 5MHz CCs, 6 for 10MHz CCs, 8 for 15MHz and 20MHz CCs
PMI delay (Note 2)	FDD CC	ms
	TDD CC	ms
Reporting interval	FDD CC	ms
	TDD CC	ms

Reporting mode		PUSCH 1-2
CodeBookSubsetRestriction bitmap		00000000000000000000000000000000 000011111111111111111111111100000000 00000000
CSI request field (Note 3)		'10'
PDSCH transmission mode		4
<p>Note 1: <math>P_B = 1</math>.</p> <p>Note 2: If the UE reports in an available uplink reporting instance at subframe SF#n based on PMI estimation at a downlink SF not later than SF#(n-4), this reported PMI cannot be applied at the eNB downlink before SF#(n+4).</p> <p>Note 3: Multiple CC-s under test are configured as the 1<sup>st</sup> set of serving cells by higher layers.</p> <p>Note 4: ACK/NACK bits are transmitted using PUSCH with PUCCH format 3.</p> <p>Note 5: The same PDSCH transmission mode is applied to each component carrier.</p>		

**Table 8.13.3.6.1-2: Single carrier performance with different bandwidths for multiple CA configurations for FDD PCell and SCell (FRC)**

Band - width	Reference channel		OCNG pattern	Propa- gation condi- tion	Correlation matrix and antenna config.		Reference value		
	2Rx CC	4Rx CC			2Rx CC	4Rx CC	Fraction of maximum throughput (%)	SNR (dB)	
								2Rx CC	4Rx CC
5MHz	R.72-1 FDD	R.72-1 FDD	OP.1 FDD	EPA5	4x2 Low	4x4 Low	70	23.4	19.3
10 MHz	R.72 FDD	R.72 FDD	OP.1 FDD	EPA5	4x2 Low	4x4 Low	70	21.6	18.0
15M Hz	R.72-2 FDD	R.72-2 FDD	OP.1 FDD	EPA5	4x2 Low	4x4 Low	70	21.7	17.4
20M Hz	R.72-3 FDD	R.72-3 FDD	OP.1 FDD	EPA5	4x2 Low	4x4 Low	70	21.8	17.5

**Table 8.13.3.6.1-3: Single carrier performance with different bandwidths for multiple CA configurations for TDD SCell (FRC)**

Band - width	Reference channel		OCNG pattern	Propa- gation condi- tion	Correlation matrix and antenna config.		Reference value		
	2Rx CC	4Rx CC			2Rx CC	4Rx CC	Fraction of maximum throughput (%)	SNR (dB)	
								2Rx CC	4Rx CC
5MHz	R.72-1 TDD	R.72-1 TDD	OP.1 TDD	EPA5	4x2 Low	4x4 Low	70	22.4	18.0
10 MHz	R.72 TDD	R.72 TDD	OP.1 TDD	EPA5	4x2 Low	4x4 Low	70	21.4	17.5
15M Hz	R.72-2 TDD	R.72-2 TDD	OP.1 TDD	EPA5	4x2 Low	4x4 Low	70	21.5	17.1
20M Hz	R.72-3 TDD	R.72-3 TDD	OP.1 TDD	EPA5	4x2 Low	4x4 Low	70	21.6	17.2

**Table 8.13.3.6.1-4: Minimum performance for multiple CA configurations with 2DL CCs (FRC)**

Test number	Aggregated Bandwidth (MHz)			Minimum performance requirement	UE Category
	Total	FDD CC	TDD CC		

1	2x20	20	20	As defined in Table 8.13.3.6.1-2 and Table 8.13.3.6.1-3 per CC	≥5
2	20+10	10	20	As defined in Table 8.13.3.6.1-2 and Table 8.13.3.6.1-3 per CC	≥5
3	20+15	15	20	As defined in Table 8.13.3.6.1-2 and Table 8.13.3.6.1-3 per CC	≥5
Note 1: The applicability of requirements for different CA configurations and bandwidth combination sets is defined in 8.1.2.6.					

### 8.13.3.6.2 Minimum Requirement for TDD PCell

The purpose of these tests is to verify the closed loop rank-two performance with wideband and frequency selective precoding.

For TDD FDD CA with TDD PCell and 2DL CCs, the requirements are specified in Table 8.13.3.6.2-4 based on single carrier requirement specified in Table 8.13.3.6.2-2 and Table 8.13.3.6.2-3, with the addition of the parameters in Table 8.13.3.6.2-1 and the downlink physical channel setup according to Annex C.3.2.

The test coverage for different number of component carriers is defined in 8.1.2.4.

**Table 8.13.3.6.2-1: Test Parameters for Multi-Layer Spatial Multiplexing (FRC) for CA**

Parameter		Unit	Value
Downlink power allocation	$\rho_A$	dB	-6
	$\rho_B$	dB	-6 (Note 1)
	$\sigma$	dB	3
$N_{oc}$ at antenna port		dBm/15kHz	-98
Precoding granularity		PRB	Wideband pre-coding for 1.4MHz, 4 for 3MHz and 5MHz CCs, 6 for 10MHz CCs, 8 for 15MHz and 20MHz CCs
PMI delay (Note 2)	FDD CC	ms	8
	TDD CC	ms	10 or 11
Reporting interval	FDD CC	ms	1
	TDD CC	ms	1 or 4 (Note 3)
Reporting mode			PUSCH 1-2
CodeBookSubsetRestriction bitmap			00000000000000000000000000000000 00001111111111111111111100000000 00000000
CSI request field (Note 3)			'10'
PDSCH transmission mode			4
Note 1: $P_B = 1$ .			
Note 2: If the UE reports in an available uplink reporting instance at subframe SF#n based on PMI estimation at a downlink SF not later than SF#(n-4), this reported PMI cannot be applied at the eNB downlink before SF#(n+4).			
Note 3: Multiple CC-s under test are configured as the 1 <sup>st</sup> set of serving cells by higher layers.			
Note 4: ACK/NACK bits are transmitted using PUSCH with PUCCH format 3.			
Note 5: The same PDSCH transmission mode is applied to each component carrier.			

**Table 8.13.3.6.2-2: Single carrier performance with different bandwidths for multiple CA configurations for FDD SCell (FRC)**

Band - width	Reference channel		OCNG pattern	Propagation condition	Correlation matrix and antenna config.		Reference value		
	2Rx CC	4Rx CC			2Rx CC	4Rx CC	Fraction of maximum throughput (%)	SNR (dB)	
								2Rx CC	4Rx CC
5MHz	R.72-1 FDD	R.72-1 FDD	OP.1 FDD	EPA5	4x2 Low	4x4 Low	70	23.4	19.3
10 MHz	R.72 FDD	R.72 FDD	OP.1 FDD	EPA5	4x2 Low	4x4 Low	70	21.6	18.0
15M Hz	R.72-2 FDD	R.72-2 FDD	OP.1 FDD	EPA5	4x2 Low	4x4 Low	70	21.7	17.4
20M Hz	R.72-3 FDD	R.72-3 FDD	OP.1 FDD	EPA5	4x2 Low	4x4 Low	70	21.8	17.5

**Table 8.13.3.6.2-3: Single carrier performance with different bandwidths for multiple CA configurations for TDD PCell and SCell (FRC)**

Band - width	Reference channel		OCNG pattern	Propagation condition	Correlation matrix and antenna config.		Reference value		
	2Rx CC	4Rx CC			2Rx CC	4Rx CC	Fraction of maximum throughput (%)	SNR (dB)	
								2Rx CC	4Rx CC
5MHz	R.72-1 TDD	R.72-1 TDD	OP.1 TDD	EPA5	4x2 Low	4x4 Low	70	22.4	18.0
10 MHz	R.72 TDD	R.72 TDD	OP.1 TDD	EPA5	4x2 Low	4x4 Low	70	21.4	17.5
15M Hz	R.72-2 TDD	R.72-2 TDD	OP.1 TDD	EPA5	4x2 Low	4x4 Low	70	21.5	17.1
20M Hz	R.72-3 TDD	R.72-3 TDD	OP.1 TDD	EPA5	4x2 Low	4x4 Low	70	21.6	17.2

**Table 8.13.3.6.2-4: Minimum performance for multiple CA configurations with 2DL CCs (FRC)**

Test number	Aggregated Bandwidth (MHz)			Minimum performance requirement	UE Category
	Total	FDD CC	TDD CC		
1	2x20	20	20	As defined in Table 8.13.3.6.2-2 and Table 8.13.3.6.2-3 per CC	≥5
2	20+10	10	20	As defined in Table 8.13.3.6.2-2 and Table 8.13.3.6.2-3 per CC	≥5
3	20+15	15	20	As defined in Table 8.13.3.6.1-2 and Table 8.13.3.6.1-3 per CC	≥5

Note 1: The applicability of requirements for different CA configurations and bandwidth combination sets is defined in 8.1.2.6.

### 8.13.3.7 Closed-loop spatial multiplexing performance 4Tx Antenna Port with Four layers

#### 8.13.3.7.1 Minimum Requirement for FDD PCell

The purpose of these tests is to verify the closed loop rank-four performance with wideband precoding with 4Tx and 4Rx under CA.

For TDD FDD CA with FDD PCell and 2DL CCs, the requirements are specified in Table 8.13.3.7.1-4 based on single carrier requirement specified in Table 8.13.3.7.1-2 and Table 8.13.3.7.1-3, with the addition of the parameters in Table 8.13.3.7.1-1 and the downlink physical channel setup according to Annex C.3.2.

The test coverage for different number of component carriers is defined in 8.1.2.4.

**Table 8.13.3.7.1-1: Test Parameters for Multi-Layer Spatial Multiplexing (FRC) for CA**

Parameter		Unit	Value
Downlink power allocation	$\rho_A$	dB	-6
	$\rho_B$	dB	-6 (Note 1)
	$\sigma$	dB	0
$N_{oc}$ at antenna port		dBm/15kHz	-98
Cell-specific reference signals			Antenna Ports 0,1,2,3
Precoding granularity		PRB	25 for 5MHz CCs, 50 for 10MHz CCs, 75 for 15MHz and 100 for 20MHz CCs
PMI delay (Note 2)	FDD CC	ms	8
	TDD CC	ms	10 or 11
Reporting interval	FDD CC	ms	1
	TDD CC	ms	1 or 4 (Note 3)
Reporting mode			PUSCH 3-1
CodeBookSubsetRestriction bitmap			0xFFFF000000000000
CSI request field (Note 3)			'10'
PDSCH transmission mode			4
PDSCH rank			4
Note 1: $P_B = 1$ .			
Note 2: If the UE reports in an available uplink reporting instance at subframe SF#n based on PMI estimation at a downlink SF not later than SF#(n-4), this reported PMI cannot be applied at the eNB downlink before SF#(n+4).			
Note 3: Multiple CC-s under test are configured as the 1 <sup>st</sup> set of serving cells by higher layers.			
Note 4: ACK/NACK bits are transmitted using PUSCH with PUCCH format 1b with channel selection			
Note 5: The same PDSCH transmission mode is applied to each component carrier.			

**Table 8.13.3.7.1-2: Single carrier performance with different bandwidths for multiple CA configurations for FDD PCell and SCell (FRC)**

Band-width	Reference channel	OCNG pattern	Propagation condition	Correlation matrix and antenna config	Reference value	
					Fraction of maximum throughput (%)	SNR (dB)
5MHz	R.74-1 FDD	OP.1 FDD	EPA5	4x4 Low	70	14.1
10MHz	R.74 FDD	OP.1 FDD	EPA5	4x4 Low	70	14.9
15MHz	R.74-2 FDD	OP.1 FDD	EPA5	4x4 Low	70	14.3
20MHz	R.74-3 FDD	OP.1 FDD	EPA5	4x4 Low	70	14.4

**Table 8.13.3.7.1-3: Single carrier performance with different bandwidths for multiple CA configurations for TDD SCell (FRC)**

Bandwidth	Reference channel	OCNG pattern	Propagation condition	Correlation matrix and antenna config	Reference value	
					Fraction of maximum throughput (%)	SNR (dB)
5MHz	R.74-1 TDD	OP.1 TDD	EPA5	4x4 Low	70	14.5
10MHz	R.74 TDD	OP.1 TDD	EPA5	4x4 Low	70	14.4
15MHz	R.74-2 TDD	OP.1 TDD	EPA5	4x4 Low	70	14.6
20MHz	R.74-3 TDD	OP.1 TDD	EPA5	4x4 Low	70	14.8

**Table 8.13.3.7.1-4: Minimum performance for multiple CA configurations with 2DL CCs (FRC)**

Test number	Aggregated Bandwidth (MHz)			Minimum performance requirement	UE Category
	Total	FDD CC	TDD CC		
1	2x20	20	20	As defined in Table 8.13.3.7.1-2 and Table 8.13.3.7.1-3 per CC	≥5
2	20+10	10	20	As defined in Table 8.13.3.7.1-2 and Table 8.13.3.7.1-3 per CC	≥5
3	20+15	15	20	As defined in Table 8.13.3.7.1-2 and Table 8.13.3.7.1-3 per CC	≥5
Note 1: The applicability of requirements for different CA configurations and bandwidth combination sets is defined in 8.1.2.6.					

### 8.13.3.7.2 Minimum Requirement for TDD PCell

The purpose of these tests is to verify the closed loop rank-four performance with wideband precoding with 4Tx and 4Rx under CA.

For TDD FDD CA with TDD PCell and 2DL CCs, the requirements are specified in Table 8.13.3.7.2-4 based on single carrier requirement specified in Table 8.13.3.7.2-2 and Table 8.13.3.7.2-3, with the addition of the parameters in Table 8.13.3.7.2-1 and the downlink physical channel setup according to Annex C.3.2.

The test coverage for different number of component carriers is defined in 8.1.2.4.

**Table 8.13.3.7.2-1: Test Parameters for Multi-Layer Spatial Multiplexing (FRC) for CA**

Parameter	Unit	Value
Downlink power allocation	$\rho_A$	dB
	$\rho_B$	dB
	$\sigma$	dB
$N_{oc}$ at antenna port	dBm/15kHz	-98
Cell-specific reference signals		Antenna Ports 0,1,2,3
Precoding granularity	PRB	25 for 5MHz CCs, 50 for 10MHz CCs, 75 for 15MHz and 100 for 20MHz CCs
PMI delay (Note 2)	FDD CC	ms
	TDD CC	ms
Reporting interval	FDD CC	ms
	TDD CC	ms



Reporting mode		PUSCH 3-1
CodeBookSubsetRestriction bitmap		0xFFFF000000000000
CSI request field (Note 3)		'10'
PDSCH transmission mode		4
PDSCH rank		4
<p>Note 1: <math>P_B = 1</math>.</p> <p>Note 2: If the UE reports in an available uplink reporting instance at subframe SF#n based on PMI estimation at a downlink SF not later than SF#(n-4), this reported PMI cannot be applied at the eNB downlink before SF#(n+4).</p> <p>Note 3: Multiple CC-s under test are configured as the 1<sup>st</sup> set of serving cells by higher layers.</p> <p>Note 4: ACK/NACK bits are transmitted using PUSCH with PUCCH format 1b with channel selection</p> <p>Note 5: The same PDSCH transmission mode is applied to each component carrier.</p>		

**Table 8.13.3.7.2-2: Single carrier performance with different bandwidths for multiple CA configurations for FDD SCell (FRC)**

Band-width	Reference channel	OCNG pattern	Propagation condition	Correlation matrix and antenna config	Reference value	
					Fraction of maximum throughput (%)	SNR (dB)
5MHz	R.74-1 FDD	OP.1 FDD	EPA5	4x4 Low	70	14.1
10MHz	R.74 FDD	OP.1 FDD	EPA5	4x4 Low	70	14.9
15MHz	R.74-2 FDD	OP.1 FDD	EPA5	4x4 Low	70	14.3
20MHz	R.74-3 FDD	OP.1 FDD	EPA5	4x4 Low	70	14.4

**Table 8.13.3.7.2-3: Single carrier performance with different bandwidths for multiple CA configurations for TDD PCell and SCell (FRC)**

Band-width	Reference channel	OCNG pattern	Propagation condition	Correlation matrix and antenna config	Reference value	
					Fraction of maximum throughput (%)	SNR (dB)
5MHz	R.74-1 TDD	OP.1 TDD	EPA5	4x4 Low	70	14.5
10MHz	R.74 TDD	OP.1 TDD	EPA5	4x4 Low	70	14.4
15MHz	R.74-2 TDD	OP.1 TDD	EPA5	4x4 Low	70	14.6
20MHz	R.74-3 TDD	OP.1 TDD	EPA5	4x4 Low	70	14.8

**Table 8.13.3.7.2-4: Minimum performance for multiple CA configurations with 2DL CCs (FRC)**

Test number	Aggregated Bandwidth (MHz)			Minimum performance requirement	UE Category
	Total	FDD CC	TDD CC		
1	2x20	20	20	As defined in Table 8.13.3.7.2-2 and Table 8.13.3.7.2-3 per CC	≥5
2	20+10	10	20	As defined in Table 8.13.3.7.2-2 and Table 8.13.3.7.2-3 per CC	≥5
3	20+15	15	20	As defined in Table 8.13.3.7.2-2 and Table 8.13.3.7.2-3 per CC	≥5
<p>Note 1: The applicability of requirements for different CA configurations and bandwidth combination sets is defined in 8.1.2.6.</p>					

## 8.14 Demodulation (UE supporting Short TTI)

The performance requirements specified in this clause are valid for UEs capable of short TTI.

### 8.14.1 Slot-PDSCH and Subslot-PDSCH

#### 8.14.1.1 FDD (Fixed Reference Channel)

The parameters specified in Table 8.14.1.1-1 are valid for FDD unless otherwise stated.

**Table 8.14.1.1-1: Common Test Parameters**

Parameter	Unit	Value
Cyclic prefix		Normal
Cell ID		0
Number of HARQ processes	Processes	8 for Slot-PDSCH 8 for subslot-PDSCH with proc-Timeline=set1 (Note 1) 12 for subslot-PDSCH with proc-Timeline=set2 (Note 1)
Minimum Processing Time (Note 2)		$X_p=4$ (proc-Timeline=set1) $X_p=6$ (proc-Timeline=set2)
Maximum number of HARQ transmission		4
Redundancy version coding sequence		{0,1,2,3}
Number of OFDM symbols for PDCCH	OFDM symbols	2
Note 1: As specified in TS36.211 Table 8.1-2.		
Note 2: Subslot-PDSCH only. As specified in TS36.213 7.3.		

#### 8.14.1.1.1 Open-loop spatial multiplexing performance

The requirements are specified in Table 8.14.1.1.1-3, with the addition of the parameters in Table 8.14.1.1.1-1 and Table 8.14.1.1.1-2, and the downlink physical channel setup according to Annex C.3.2.

**Table 8.14.1.1.1-1: Test Parameters for PDSCH**

Parameter	Unit	Test 1	Test 2
Unused RE-s and PRB-s		OCNG	OCNG
Cell ID		0	0
Downlink power allocation	$\rho_A$	dB	-6
	$\rho_B$	dB	-6
	$\sigma$	dB	0
$N_{oc}$ at antenna port	dBm/15kHz	-98	-98
Subframe configuration		Non-MBSFN	Non-MBSFN
Cell specific reference signal		Antenna ports 0,1,2,3	Antenna ports 0,1,2,3
DL TTI length		Slot	Subslot
Configured SPDCCH-PRB sets		{Set 1, Set 2}	{Set 1, Set 2}
SPDCCH-PRB set used for DCI transmission		Set 1	Set 2
Used/Unused SPDCCH resource indication		N/A	'10'
PDSCH transmission mode		TM3	TM3
DCI format		7-1B	7-1B

**Table 8.14.1.1.1-2: SPDCCH-PRB set parameters**

Parameter	Unit	Set 1	Set 2
Reference symbol		CRS	CRS
Transmission type		Localized	Localized
Number of OFDM symbols		1	1
Number of PRBs per SPDCCH-PRB set (Note 1)		16	16
Rate Matching mode		Mode 1	Not configured
SPDCCH L1 Reuse Indication		Not configured	{2, 0}
Aggregation level	SCCE	2	2

Note 1: The two SPDCCH-PRB sets are non-overlapping with PRB = {0, 1, ..., 15} for Set 1, and PRB = {35, 36, ..., 49} for Set 2

**Table 8.14.1.1.1-3: Minimum performance Large Delay CDD (FRC)**

Test num	Bandwidth and MCS	Reference channel	OCNG pattern	Propagation condition	Correlation matrix and antenna config.	Reference value		UE category
						Fraction of maximum Throughput (%)	SNR (dB)	
1	10 MHz 16QAM 0.5	R.sTTI.1 FDD	OP.1 FDD	EVA30	4x2 Low	70	13.6	≥2
2	10 MHz 16QAM 0.45	R.sTTI.2 FDD	OP.1 FDD	EVA30	4x2 Low	70	11.6	≥2

#### 8.14.1.1.2 Closed-loop spatial multiplexing performance (User-Specific Reference Signals)

The requirements are specified in Table 8.14.1.1.2-3, with the addition of the parameters in Table 8.14.1.1.2-1 and Table 8.14.1.1.2-2, and the downlink physical channel setup according to Annex C.3.2.

Table 8.14.1.1.2-1: Test Parameters for PDSCH

Parameter	Unit	Test 1	Test 2
Unused RE-s and PRB-s		OCNG	OCNG
Cell ID		0	0
Downlink power allocation	$\rho_A$	dB	-3
	$\rho_B$	dB	-3
	$\sigma$	dB	0
$N_{oc}$ at antenna port	dBm/15kHz	-98	-98
CSI-RS signals		Antenna ports 15, 16	Antenna ports 15, 16
CSI-RS periodicity and subframe offset		5 / 2	5 / 2
CSI-RS configuration		0	0
Zero-power CSI-RS configuration		Not configured	Not configured
Subframe configuration		Non-MBSFN	Non-MBSFN
Precoder update granularity	SREG	2	2
	ms	1	1
Beamforming precoder		Annex B.4.2	Annex B.4.2
Cell specific reference signal		0, 1	0, 1
DL TTI length		Slot	Subslot
DMRS position indicator		N/A	0 for subslots 1,3, and 5 1 for subslots 2 and 4
Configured SPDCCH-PRB sets		{Set 1, Set 2}	{Set 1, Set 2}
SPDCCH-PRB set used for DCI transmission		Set 1	Set 2
Used/Unused SPDCCH resource indication		'10'	N/A
PDSCH transmission mode		TM9	TM9
DCI format		7-1F	7-1F

Table 8.14.1.1.2-2: SPDCCH-PRB set parameters

Parameter	Unit	Set 1	Set 2
Reference signal		CRS	CRS
Transmission type		Localized	Localized
Number of OFDM symbols		2	2
Number of PRBs per SPDCCH-PRB set (Note 1)		8	8
Rate Matching mode		Not configured	Mode 1
SPDCCH L1 Reuse Indication		{1, 1}	Not configured
Aggregation level	SCCE	4	4
Note 1: The two SPDCCH-PRB sets are non-overlapping with PRB = {0, 1, ..., 7} for Set 1, and PRB = {8, 9, ..., 15} for Set 2			

Table 8.14.1.1.2-3: Minimum performance Large Delay CDD (FRC)

Test num	Bandwidth and MCS	Reference channel	OCNG pattern	Propagation condition	Correlation matrix and antenna config.	Reference value		UE category
						Fraction of maximum Throughput (%)	SNR (dB)	
1	10 MHz QPSK 1/3	R.sTTI.3 FDD	OP.1 FDD	EPA5	2x2 Low	70	7.1	≥2
2	10 MHz QPSK 1/3	R.sTTI.4 FDD	OP.1 FDD	EPA5	2x2 Low	70	8.4	≥2

## 8.14.1.2 TDD (Fixed Reference Channel)

The parameters specified in Table 8.14.1.2-1 are valid for TDD unless otherwise stated.

Table 8.14.1.2-1: Common Test Parameters

Parameter	Unit	Value
Cyclic prefix		Normal
Cell ID		0
Number of HARQ processes	Processes	8 (Slot-PDSCH)
Maximum number of HARQ transmission		4
Redundancy version coding sequence		{0,1,2,3}
Number of OFDM symbols for PDCCH	OFDM symbols	2
Uplink downlink configuration (Note 1)		1
Special subframe configuration (Note 2)		4
ACK/NACK feedback mode		Multiplexing
Note 1:	as specified in Table 4.2-2 in TS 36.211 [4]	
Note 2:	as specified in Table 4.2-1 in TS 36.211 [4]	

## 8.14.1.2.1 Open-loop spatial multiplexing performance

The requirements are specified in Table 8.14.1.2.1-3, with the addition of the parameters in Table 8.14.1.2.1-1 and Table 8.14.1.2.1-2, and the downlink physical channel setup according to Annex C.3.2.

Table 8.14.1.2.1-1: Test Parameters for PDSCH

Parameter	Unit	Test 1	
Number of PDCCH symbols	symbols	2	
Unused RE-s and PRB-s		OCNG	
Cell ID		0	
Downlink power allocation	$\rho_A$	dB	-6
	$\rho_B$	dB	-6
	$\sigma$	dB	0
$N_{oc}$ at antenna port	dBm/15kHz	-98	
Subframe configuration		Non-MBSFN	
Cell specific reference signal		Antenna ports 0,1,2,3	
DL TTI length		Slot	
Configured SPDCCH-PRB sets		{Set 1, Set 2}	
SPDCCH-PRB set used for DCI transmission		Set 1	
Used/Unused SPDCCH resource indication		N/A	
PDSCH transmission mode		TM3	
DCI format		7-1B	

Table 8.14.1.2.1-2: SPDCCH-PRB set parameters

Parameter	Unit	Set 1	Set 2
Reference signal		CRS	CRS
Transmission type		Localized	Localized
Number of OFDM symbols		1	1
Number of PRBs per SPDCCH-PRB set (Note 1)		16	16
Rate Matching mode		Mode 1	Not configured
SPDCCH L1 Reuse Indication		Not configured	{2, 0}
Aggregation level	SCCE	2	2

Note 1: The two SPDCCH-PRB sets are non-overlapping with PRB = {0, 1, ..., 15} for Set 1, and PRB = {35, 36, ..., 49} for Set 2

Table 8.14.1.2.1-3: Minimum performance Large Delay CDD (FRC)

Test num	Bandwidth and MCS	Reference channel	OCNG pattern	Propagation condition	Correlation matrix and antenna config.	Reference value		UE category
						Fraction of maximum Throughput (%)	SNR (dB)	
1	10 MHz 16QAM 0.5	R.sTTI.1 FDD	OP.1 TDD	EVA30	4x2 Low	70	13.5	≥2

## 8.14.1.2.2 Closed-loop spatial multiplexing performance (User-Specific Reference Signals)

The requirements are specified in Table 8.14.1.2.2-3, with the addition of the parameters in Table 8.14.1.2.2-1 and Table 8.14.1.2.2-2, and the downlink physical channel setup according to Annex C.3.2.

Table 8.14.1.2.2-1: Test Parameters for PDSCH

Parameter	Unit	Test 1	
Number of PDCCH symbols	symbols	2	
Unused RE-s and PRB-s		OCNG	
Cell ID		0	
Downlink power allocation	$\rho_A$	dB	-3
	$\rho_B$	dB	-3
	$\sigma$	dB	0
$N_{oc}$ at antenna port	dBm/15kHz	-98	
CSI-RS signals		Antenna ports 15, 16	
CRS-RS periodicity and subframe offset		5 / 4	
CSI-RS configuration		0	
Zero-power CRI-RS configuration		Not configured	
Subframe configuration		Non-MBSFN	
Precoder update granularity	SREG	2	
	ms	1	
Beamforming precoder		Annex B.4.2	
Cell specific reference signal		0,1	
DL TTI length		Slot	
Configured SPDCCH-PRB sets		{Set 1, Set 2}	
SPDCCH-PRB set used for DCI transmission		Set 1	
Used/Unused SPDCCH resource indication		'10'	
PDSCH transmission mode		TM9	
DCI format		7-1F	

Table 8.14.1.2.2-2: SPDCCH-PRB set parameters

Parameter	Unit	Set 1	Set 2
Reference symbol		CRS	CRS
Transmission type		Localized	Localized
Number of OFDM symbols		2	2
Number of PRBs per SPDCCH-PRB set (Note 1)		8	8
Rate Matching mode		Not configured	Mode 1
SPDCCH L1 Reuse Indication		{1, 1}	Not configured
Aggregation level	SCCE	4	4

Note 1: The two SPDCCH-PRB sets are non-overlapping with PRB = {0, 1, ..., 7} for Set 1, and PRB = {8, 9, ..., 15} for Set 2

Table 8.14.1.2.2-3: Minimum performance Large Delay CDD (FRC)

Test num	Bandwidth and MCS	Reference channel	OCNG pattern	Propagation condition	Correlation matrix and antenna config.	Reference value		UE category
						Fraction of maximum Throughput (%)	SNR (dB)	
1	10 MHz QPSK 1/3	R.sTTI.2 TDD	OP.1 TDD	EPA5	2x2 Low	70	6.8	≥2

## 8.14.2 SPDCCH

The receiver characteristics of the SPDCCH are determined by the probability of miss-detection of the Downlink Scheduling Grant (Pm-dsg).

### 8.14.2.1 FDD

The parameters specified in Table 8.14.2.1-1 and Table 8.14.2.1-2 are valid for all FDD tests unless otherwise stated.

Table 8.14.2.1-1: Test Parameters for SPDCCH

Parameter	Unit	Test 1 Test 3	Test 2 Test 4
Number of PDCCH symbols	symbols	2	2
Unused RE-s and PRB-s		OCNG	OCNG
Cell ID		0	0
Downlink power allocation	$\rho_A$	-6	-3
	$\rho_B$	-6	-3
	$\sigma$	0	0
	$\delta$	N/A	3
$N_{oc}$ at antenna port	dBm/15kHz	-98	-98
Cyclic prefix		Normal	Normal
Subframe configuration		Non-MBSFN	Non-MBSFN
Precoder update granularity	SREG	N/A	2
	ms	N/A	1
Beamforming precoder		N/A	Annex B.4.4
Cell specific reference signal		Antenna ports 0,1,2,3	Antenna ports 0,1
Configured SPDCCH-PRB sets		{Set 1}	{Set 2}
SPDCCH-PRB set used for DCI transmission		Set 1	Set 2
PDSCH transmission mode		TM4	TM9
DCI format		7-1C	7-1F

Note 1: For slot-based transmission, DCI 7-1C and 7-1F are transmitted only on SPDCCH in slot 1. For subslot-based transmission, DCI 7-1C and 7-1F are transmitted on SPDCCH in all the subslots.

**Table 8.14.2.1-2: SPDCCH-PRB set parameters**

Parameter	Unit	Set 1	Set 2
Reference symbol		CRS	DMRS
Transmission type		Localized	Distributed
Number of OFDM symbols		1	Note 2
Number of PRBs per SPDCCH-PRB set (Note 1)		16	16
Note 1:	The two SPDCCH-PRB sets are non-overlapping with PRB = {0, 1, ..., 15} for Set 1 and PRB = {0, 1, 6, 7, 12, 13, 18, 19, 28, 29, 34, 35, 40, 41, 46, 47} for Set 2.		
Note 2:	2 OFDM symbols for slot-based SPDCCH. 2 OFDM symbols for subslot indices 2, 3, and 4, and 3 OFDM symbols for subslot indices 1 and 5 for subslot-based SPDCCH.		

#### 8.14.2.1.1 Minimum requirement

For the parameters specified in Table 8.14.2.1-1 and Table 8.14.2.1-2 the average probability of a missed downlink scheduling grant ( $P_{m-dsg}$ ) shall be below the specified value in Table 8.14.2.1.1-1. The metric  $P_{m-dsg}$  is calculated across all the slots for slot-based SPDCCH and across all the subslots for subslot-based SPDCCH. The downlink physical setup is in accordance with Annex C.3.2.

**Table 8.14.2.1.1-1: Minimum performance SPDCCH**

Test number	Bandwidth	DL TTI length	Aggregation Level	Reference Channel	OCNG Pattern	Propagation Condition	Antenna configuration and correlation Matrix	Reference value	
								$P_{m-dsg}$ (%)	SNR (dB)
1	10 MHz	Slot	2 SCCE	R.sTTI.10 FDD	OP.7 FDD	EVA30	4 x 2 Low	1	2.9
2	10 MHz	Slot	8 SCCE	R.sTTI.11 FDD	OP.7 FDD	EPA5	2 x 2 Low	1	1.3
3	10 MHz	Subslot	2 SCCE	R.sTTI.10 FDD	OP.7 FDD	EVA30	4 x 2 Low	1	2.3
4	10 MHz	Subslot	8 SCCE	R.sTTI.11 FDD	OP.7 FDD	EPA5	2 x 2 Low	1	0.9

#### 8.14.2.2 TDD

The parameters specified in Table 8.14.2.2-1 and Table 8.14.2.2-2 are valid for all TDD tests unless otherwise stated.



Table 8.14.2.2-1: Test Parameters for SPDCCH

Parameter		Unit	Test 1	Test 2
Number of PDCCH symbols		symbols	2	2
Unused RE-s and PRB-s			OCNG	OCNG
Cell ID			0	0
Downlink power allocation	$\rho_A$	dB	-6	-3
	$\rho_B$	dB	-6	-3
	$\sigma$	dB	0	0
	$\delta$	dB	N/A	3
$N_{oc}$ at antenna port		dBm/15kHz	-98	-98
Cyclic prefix			Normal	Normal
Subframe configuration			Non-MBSFN	Non-MBSFN
Precoder update granularity	SREG		N/A	2
	ms		N/A	1
Beamforming precoder			N/A	Annex B.4.4
Cell specific reference signal			Antenna ports 0,1,2,3	Antenna ports 0,1
Configured SPDCCH-PRB sets			{Set 1}	{Set 2}
SPDCCH-PRB set used for DCI transmission			Set 1	Set 2
PDSCH transmission mode			TM4	TM9
DCI format			7-1C	7-1F
TDD UL/DL Configuration			0	0
TDD Special Subframe			1	1
Note 1: For slot-based transmission, DCI 7-1C and 7-1F are transmitted only on SPDCCH in slot 1. For subslot-based transmission, DCI 7-1C and 7-1F are transmitted on SPDCCH in all the subslots.				

Table 8.14.2.2-2: SPDCCH-PRB set parameters

Parameter	Unit	Set 1	Set 2
Reference symbol		CRS	DMRS
Transmission type		Localized	Distributed
Number of OFDM symbols		1	Note 2
Number of PRBs per SPDCCH-PRB set (Note 1)		16	16
Note 1: The two SPDCCH-PRB sets are non-overlapping with PRB = {0, 1, ..., 15} for Set 1 and PRB = {0, 1, 6, 7, 12, 13, 18, 19, 28, 29, 34, 35, 40, 41, 46, 47} for Set 2.			
Note 2: 2 OFDM symbols for slot-based SPDCCH. 2 OFDM symbols for subslot indices 2, 3, and 4, and 3 OFDM symbols for subslot indices 1 and 5 for subslot-based SPDCCH.			

#### 8.14.2.2.1 Minimum requirement

For the parameters specified in Table 8.14.2.2-1 and Table 8.14.2.2-2 the average probability of a missed downlink scheduling grant ( $P_{m-dsg}$ ) shall be below the specified value in Table 8.14.2.2.1-1. The metric  $P_{m-dsg}$  is calculated across all the slots. The downlink physical setup is in accordance with Annex C.3.2.

Table 8.14.2.2.1-1: Minimum performance SPDCCH

Test number	Bandwidth	DL TTI length	Aggregation Level	Reference Channel	OCNG Pattern	Propagation Condition	Antenna configuration and correlation Matrix	Reference value	
								$P_{m-dsg}$ (%)	SNR (dB)
1	10 MHz	Slot	2 SCCE	R.sTTI.10 TDD	OP.7 TDD	EVA30	4 x 2 Low	1	2.7
2	10 MHz	Slot	8 SCCE	R.sTTI.11 TDD	OP.7 TDD	EPA5	2 x 2 Low	1	1.2

## 8.15 Demodulation (8 receiver antenna ports)

### 8.15.1 PDSCH

#### 8.15.1.1 Void

#### 8.15.1.2 TDD (Fixed Reference Channel)

The parameters specified in Table 8.15.1.2-1 are valid for all TDD tests unless otherwise stated.

**Table 8.15.1.2-1: Common Test Parameters (TDD)**

Parameter	Unit	Value
Uplink downlink configuration (Note 1)		1
Special subframe configuration (Note 2)		4
Cyclic prefix		Normal
Cell ID		0
Inter-TTI Distance		1
Number of HARQ processes per component carrier	Processes	7
Maximum number of HARQ transmission		4
Redundancy version coding sequence		{0,1,2,3} for QPSK and 16QAM {0,0,1,2} for 64QAM and 256QAM
Number of OFDM symbols for PDCCH	OFDM symbols	4 for 1.4 MHz bandwidth, 3 for 3 MHz and 5 MHz bandwidths, 2 for 10 MHz, 15 MHz and 20 MHz bandwidths unless otherwise stated
Cross carrier scheduling		Not configured
Precoder update granularity		Frequency domain: 1 PRG for Transmission modes 9 and 10 unless stated otherwise Time domain: 1 ms
ACK/NACK feedback mode		Multiplexing
Note 1:	as specified in Table 4.2-2 in TS 36.211 [4].	
Note 2:	as specified in Table 4.2-1 in TS 36.211 [4].	

#### 8.15.1.2.1 Transmit diversity performance with 2Tx Antenna Ports (Cell-Specific Reference Symbols)

The requirements are specified in Table 8.15.1.2.1-2, with the addition of the parameters in Table 8.15.1.2.1-1 and the downlink physical channel setup according to Annex C.3.2. The purpose is to verify the performance of transmit diversity (SFBC) with 2 transmitter antennas.

**Table 8.15.1.2.1-1: Test Parameters for Transmit diversity Performance (FRC) with 8Rx Antenna Ports**

Parameter	Unit	Test 1
Downlink power allocation	$\rho_A$	dB
	$\rho_B$	dB
	$\sigma$	dB
$N_{oc}$ at antenna port		dBm/15kHz
PDSCH transmission mode		2
Note 1: $P_B = 1$		

**Table 8.15.1.2.1-2: Minimum performance Transmit Diversity (FRC) with 8Rx Antenna Ports**

Test number	Bandwidth and MCS	Reference Channel	OCNG Pattern	Propagation Condition	Correlation Matrix and Antenna Configuration	Reference value		UE Category
						Fraction of Maximum Throughput (%)	SNR (dB)	
1	10 MHz 16QAM 1/2	R.11 TDD	OP.1 TDD	EVA5	2x8 Medium correlation B, ULA	70	1.4	$\geq 2$

### 8.15.1.2.2 Open-loop spatial multiplexing performance with 2Tx Antenna Ports (Cell-Specific Reference Symbols)

The requirements are specified in Table 8.15.1.2.2-2, with the addition of the parameters in Table 8.15.1.2.2-1 and the downlink physical channel setup according to Annex C.3.2.

**Table 8.15.1.2.2-1: Test Parameters for Large Delay CDD (FRC) with 8Rx Antenna Ports**

Parameter	Unit	Test 1
Downlink power allocation	$\rho_A$	dB
	$\rho_B$	dB
	$\sigma$	dB
$N_{oc}$ at antenna port		dBm/15kHz
ACK/NACK feedback mode		Bundling
PDSCH transmission mode		3
Note 1: $P_B = 1$		

**Table 8.15.1.2.2-2: Minimum performance Large Delay CDD (FRC) with 8Rx Antenna Ports**

Test number	Bandwidth and MCS	Reference Channel	OCNG Pattern	Propagation Condition	Correlation Matrix and Antenna Configuration	Reference value		UE Category
						Fraction of Maximum Throughput (%)	SNR (dB)	
1	10 MHz 16QAM 1/2	R.11-1 TDD	OP.1 TDD	EVA70	2x8 Low	70	4.1	$\geq 2$

### 8.15.1.2.3 8 Layer Spatial Multiplexing (User-Specific Reference Symbols)

The requirements are specified in Table 8.15.1.2.3-2, with the addition of the parameters in Table 8.15.1.2.3-1 and the downlink physical channel setup according to Annex C.3.2.

**Table 8.15.1.2.3-1: Minimum performance for 8 Layer Spatial Multiplexing (User-Specific Reference Symbols)**

Parameter	Unit	Test 1	
Downlink power allocation	$\rho_A$	dB	0
	$\rho_B$	dB	0 (Note 1)
	$\sigma$	dB	-3
Beamforming model		8 layer precoding based on WB PMI feedback	
Cell-specific reference signals		Antenna ports 0,1	
CSI reference signals		Antenna ports 15,...,22	
CSI-RS periodicity and subframe offset $T_{\text{CSI-RS}} / \Delta_{\text{CSI-RS}}$	Subframes	5 / 4	
CSI reference signal configuration		3	
Zero-power CSI-RS configuration $l_{\text{CSI-RS}} /$ ZeroPowerCSI-RS bitmap	Subframes / bitmap	4 / 0010000000000000	
$N_{oc}$ at antenna port	dBm/15kHz	-98	
Symbols for unused PRBs		OCNG (Note 3)	
Number of allocated resource blocks (Note 2)	PRB	50	
Simultaneous transmission		No	
PDSCH transmission mode		9	
Precoding granularity		50	
PMI delay		10 or 11	
Reporting interval		1 or 4	
Reporting mode		PUSCH 3-1	
alternativeCodeBookEnabledFor4TX-r12		False	
CodeBookSubsetRestriction bitmap		0x0000 0000 0000 0010 0000 0000 0000	
Note 1: $P_B = 1$			
Note 2: 50 resource blocks are allocated in sub-frames 4, 9 and 41 resource blocks (RB0–RB20 and RB30–RB49) are allocated in sub-frame 0, 1 and 6.			
Note 3: These physical resource blocks are assigned to an arbitrary number of virtual UEs with one PDSCH per virtual UE; the data transmitted over the OCNG PDSCHs shall be uncorrelated pseudo random data, which is QPSK modulated.			
Note 4: Number of OFDM symbols for PDCCH: 2			

**Table 8.15.1.2.3-2: Minimum performance for 8 Layer Spatial Multiplexing (User-Specific Reference Symbols)**

Test number	Bandwidth and MCS	Reference Channel	OCNG Pattern	Propagation Condition	Correlation Matrix and Antenna Configuration	Reference value		UE Category	Dl Ca
						Fraction of Maximum Throughput (%)	SNR (dB)		
1	10 MHz 16QAM	R.50-4 TDD	OP.1 TDD	EPA5	8x8 Low	70	18.5	8	17 9, 2, 2

## 8.15.2 CA

## 8.15.2.1 Void

## 8.15.2.2 TDD

The parameters specified in Table 8.15.2.2-1 are valid for all TDD CA and DC tests unless otherwise stated.

**Table 8.15.2.2-1: Common Test Parameters (TDD)**

Parameter	Unit	Value
Uplink downlink configuration (Note 1)		1
Special subframe configuration (Note 2)		4
Cyclic prefix		Normal
Cell ID		0
Inter-TTI Distance		1
Number of HARQ processes per component carrier	Processes	7
Maximum number of HARQ transmission		4
Redundancy version coding sequence		{0,1,2,3} for QPSK and 16QAM {0,0,1,2} for 64QAM and 256QAM
Number of OFDM symbols for PDCCH per component carrier	OFDM symbols	4 for 1.4 MHz bandwidth, 3 for 3 MHz and 5 MHz bandwidths, 2 for 10 MHz, 15 MHz and 20 MHz bandwidths unless otherwise stated
Cross carrier scheduling		Not configured
Note 1: as specified in Table 4.2-2 in TS 36.211 [4].		
Note 2: as specified in Table 4.2-1 in TS 36.211 [4].		

## 8.15.2.2.1 Eight Layer Spatial Multiplexing (User-Specific Reference Symbols)

## 8.15.2.2.1.1 Minimum Requirement Eight-Layer Spatial Multiplexing 8 Tx Antenna Port

The purpose of these tests is to verify the closed loop rank-eight performance with frequency selective precoding with 8Tx and 8Rx under CA.

For CA with 2 DL CCs, the requirements are specified in Table 8.15.2.2.1.1-3, based on single carrier requirement specified in Table 8.15.2.2.1.1-2, with the addition of the parameters in Table 8.15.2.2.1.1-1 and the downlink physical channel setup according to Annex C.3.2.

Table 8.15.2.2.1.1-1: Test Parameters for Multi-Layer Spatial Multiplexing (FRC) for CA

Parameter	Unit	Test 1	
ownlink power allocation	$\rho_A$	dB	0
	$\rho_B$	dB	0 (Note 1)
	$\sigma$	dB	-3
Cell-specific reference signals		Antenna ports 0,1	
CSI reference signals		Antenna ports 15,...,22	
Beamforming model		Annex B.4.3(Note 4, 5)	
CSI-RS periodicity and subframe offset $T_{\text{CSI-RS}} / \Delta_{\text{CSI-RS}}$	Subframes	5 / 2	
CSI reference signal configuration		3	
Zero-power CSI-RS configuration $I_{\text{CSI-RS}} / \text{ZeroPowerCSI-RS bitmap}$	Subframes / bitmap	3 / 0001000000000000	
$N_{oc}$ at antenna port	dBm/15kHz	-98	
Symbols for unused PRBs		OCNG (Note 3)	
Number of allocated resource blocks (Note 2)	PRB	50	
Simultaneous transmission		No	
PDSCH transmission mode		9	
Precoding granularity		50	
PMI delay		8	
Reporting interval		5	
Reporting mode		PUSCH 3-1	
alternativeCodeBookEnabledFor4TX-r12		False	
CodeBookSubsetRestriction bitmap		0x0000 0000 0000 0010 0000 0000 0000	
<p>Note 1: <math>P_B = 1</math>.</p> <p>Note 2: 50 resource blocks are allocated in sub-frames 1,2,3,4,6,7,8,9 and 41 resource blocks (RB0–RB20 and RB30–RB49) are allocated in sub-frame 0.</p> <p>Note 3: These physical resource blocks are assigned to an arbitrary number of virtual UEs with one PDSCH per virtual UE; the data transmitted over the OCNG PDSCHs shall be uncorrelated pseudo random data, which is QPSK modulated.</p> <p>Note 4: The precoder in clause B.4.3 follows UE recommended PMI.</p> <p>Note 5: If the UE reports in an available uplink reporting instance at subframe SF#n based on PMI estimation at a downlink SF not later than SF#(n-4), this reported PMI cannot be applied at the eNB downlink before SF#(n+4).</p>			

Table 8.15.2.2.1.1-2: Single carrier performance for multiple CA configurations

Bandwidth	Reference channel	OCNG pattern	Propagation condition	Correlation matrix and antenna config	Reference value	
					Fraction of maximum throughput (%)	SNR (dB)
5MHz	R.50-3 TDD	OP.1 TDD	EPA5	8x8 Low	70	17.6
10MHz	R.50-4 TDD	OP.1 TDD	EPA5	8x8 Low	70	18.5
15MHz	R.50-5 TDD	OP.1 TDD	EPA5	8x8 Low	70	18.9
20MHz	R.50-6 TDD	OP.1 TDD	EPA5	8x8 Low	70	18.9

**Table 8.15.2.2.1.1-3: Minimum performance (FRC) based on single carrier performance for CA with 2 DL CCs**

Test num.	CA Bandwidth combination	Requirement	UE category	DL UE category
1	2x20 MHz	As specified in Table 8.15.2.2.1.1-2 per CC	8	14, 17,18,19,20,22,23,24,25,26
Note 1: The applicability of requirements for different CA configurations and bandwidth combination sets is defined in 8.1.2.12.3.				

## 9 Reporting of Channel State Information

### 9.1 General

This section includes requirements for the reporting of channel state information (CSI). For all test cases in this section, the definition of SNR and SINR are in accordance with the one given in clause 8.1.1.

For the performance requirements specified in this clause, it is assumed that  $N_{RX}=2$  unless otherwise stated.

Unless otherwise stated, 4-bit CQI Table in Table 7.2.3-1 in TS 36.213 [6], and Modulation and TBS index table in Table 7.1.7.1-1 for PDSCH in TS 36.213 [6] are applied in all the CSI requirements.

#### 9.1.1 Applicability of requirements

##### 9.1.1.1 Applicability of requirements for different channel bandwidths

In Clause 9 the test cases may be defined with different channel bandwidth to verify the same CSI requirement.

Test cases defined for 5MHz channel bandwidth that reference this clause are applicable to UEs that support only Band 31, 72, 73, 87 and/or 88.

##### 9.1.1.2 Applicability and test rules for different CA configurations and bandwidth combination sets

The performance requirement for CA CQI tests in Clause 9 are defined independent of CA configurations and bandwidth combination sets specified in Clause 5.6A.1. For UEs supporting different CA configurations and bandwidth combination sets, the applicability and test rules are defined for the tests for 2 DL CCs in Table 9.1.1.2-1 and 3 or more DL CCs in Table 9.1.1.2-2. For simplicity, CA configuration below refers to combination of CA configuration and bandwidth combination set.

**Table 9.1.1.2-1: Applicability and test rules for CA UE CQI tests with 2 DL CCs**

Tests	CA capability where the tests apply	CA configuration from the selected CA capability where the tests apply	CA Bandwidth combination to be tested in priority order
CA tests with 2CCs in Clause 9.6.1.1	Any of one of the supported CA capabilities	Any one of the supported FDD CA configurations	10+10 MHz, 20+20 MHz, 5+5 MHz, 10MHz+5MHz, 15MHz+5MHz
CA tests with 2CCs in Clause 9.6.1.2	Any of one of the supported CA capabilities with largest aggregated CA bandwidth combination	Any one of the supported TDD CA configurations with largest aggregated CA bandwidth combination	Largest aggregated CA bandwidth combination
Note 1: The applicability and test rules are specified in this table, unless otherwise stated.			
Note 2: Number of the supported bandwidth combinations to be tested from each selected CA configuration is 1.			
Note 3: A single Uplink CC is configured for all tests			

**Table 9.1.1.2-2: Applicability and test rules for CA UE CQI tests with 3 or more DL CCs**

Tests	CA capability where the tests apply	CA configuration from the selected CA capability where the tests apply	CA Bandwidth combination to be tested in priority order
CA tests with 3 or more CCs in Clause 9.6.1.1	Any of one of the supported CA capabilities with largest aggregated CA bandwidth combination	Any one of the supported FDD CA configurations with largest aggregated CA bandwidth combination	Largest aggregated CA bandwidth combination
CA tests with 3 or more CCs in Clause 9.6.1.2	Any of one of the supported CA capabilities with largest aggregated CA bandwidth combination	Any one of the supported TDD CA configurations with largest aggregated CA bandwidth combination	Largest aggregated CA bandwidth combination
Note 1: The applicability and test rules are specified in this table, unless otherwise stated.			
Note 2: Number of the supported bandwidth combinations to be tested from each selected CA configuration is 1.			
Note 3: A single Uplink CC is configured for all tests			

### 9.1.1.2A Applicability and test rules for different TDD-FDD CA configurations and bandwidth combination sets

The performance requirement for TDD-FDD CA CQI tests in Clause 9 are defined independent of CA configurations and bandwidth combination sets specified in Clause 5.6A.1. For UEs supporting different CA configurations and bandwidth combination sets, the applicability and test rules are defined for the tests for 2 DL TDD-FDD CA in Table 9.1.1.2A-1 and for 3 or more DL TDD-FDD CA in Table 9.1.1.2A-2. For simplicity, CA configuration below refers to combination of CA configuration and bandwidth combination set.



**Table 9.1.1.2A-1: Applicability and test rules for CA UE CQI tests for TDD-FDD CA with 2 DL CCs**

Tests	CA capability where the tests apply	CA configuration from the selected CA capability where the tests apply	CA Bandwidth combination to be tested in priority order
CA tests with 2CCs in Clause 9.6.1.3	Any of one of the supported CA capabilities	Any one of the supported TDD-FDD CA configurations with FDD PCell with largest aggregated CA bandwidth combination	Largest aggregated CA bandwidth combination
CA tests with 2CCs in Clause 9.6.1.4	Any of one of the supported CA capabilities	Any one of the supported TDD-FDD CA configurations with TDD PCell with largest aggregated CA bandwidth combination	Largest aggregated CA bandwidth combination
Note 1: The applicability and test rules are specified in this table, unless otherwise stated. Note 2: Number of the supported bandwidth combinations to be tested from each selected CA configuration is 1. Note 3: A single Uplink CC is configured for all tests			

**Table 9.1.1.2A-2: Applicability and test rules for CA UE CQI tests for TDD-FDD CA with 3 or more DL CCs**

Tests	CA capability where the tests apply	CA configuration from the selected CA capability where the tests apply	CA Bandwidth combination to be tested in priority order
CA tests with 3CCs in Clause 9.6.1.3	Any of one of the supported CA capabilities	Any one of the supported TDD-FDD CA configurations with FDD PCell with largest aggregated CA bandwidth combination	Largest aggregated CA bandwidth combination
CA tests with 3CCs in Clause 9.6.1.4	Any of one of the supported CA capabilities	Any one of the supported TDD-FDD CA configurations with TDD PCell with largest aggregated CA bandwidth combination	Largest aggregated CA bandwidth combination
Note 1: The applicability and test rules are specified in this table, unless otherwise stated. Note 2: Number of the supported bandwidth combinations to be tested from each selected CA configuration is 1. Note 3: A single Uplink CC is configured for all tests			

### 9.1.1.3 Test coverage for different number of component carriers

For FDD CA tests specified in 9.6.1.1, among all supported CA capabilities, if corresponding CA tests with the largest number of CCs supported by the UE are tested, the test coverage can be considered fulfilled without executing the CA tests with less than the largest number of CCs supported by the UE.

For TDD CA tests specified in 9.6.1.2, among all supported CA capabilities, if corresponding CA tests with the largest number of CCs supported by the UE are tested, the test coverage can be considered fulfilled without executing the CA tests with less than the largest number of CCs supported by the UE.

For TDD FDD CA tests specified in 9.6.1.3 and 9.6.1.4, among all supported CA capabilities, if corresponding CA tests with the largest number of CCs supported by the UE are tested, the test coverage can be considered fulfilled without executing the TDD FDD CA tests with less than the largest number of CCs supported by the UE.

### 9.1.1.4 Applicability of performance requirements for 4Rx capable UEs

#### 9.1.1.4.1 Applicability rule and antenna connection for single carrier tests with 2Rx

For 4Rx capable UEs all single carrier tests specified in 9.2 to 9.5 with 2Rx are tested on any of the 2Rx supported RF bands by connecting 2 out of the 4Rx with data source from system simulator, and the other 2 Rx are connected with zero input, depending on UE's declaration and AP configuration. Same requirements specified with 2Rx should be applied.

For 4Rx capable UEs without any 2Rx supported RF bands, all single carrier tests specified in 9.2 to 9.5 with 2Rx are tested on any of the 4Rx supported RF bands by duplicating the fading channel from each Tx antenna and add

independent noise for each Rx antenna where applicable. Figure 9.1.1.4.1-1 shows an example of antenna connection for 4Rx UE in any one 4Rx supported RF band to perform a 2Rx performance test with antenna configuration as 2x2 without interference for information. The SNR requirements should be applied with 3 dB less than the number specified with 2Rx, unless there is no SNR requirements specified.

For 4Rx capable UEs without any 2Rx supported RF bands, all single carrier tests specified in 9.3.3 with 2Rx are tested on any of the 4Rx supported RF bands by duplicating the fading channel from each Tx antenna and add independent interference for each Rx antenna.

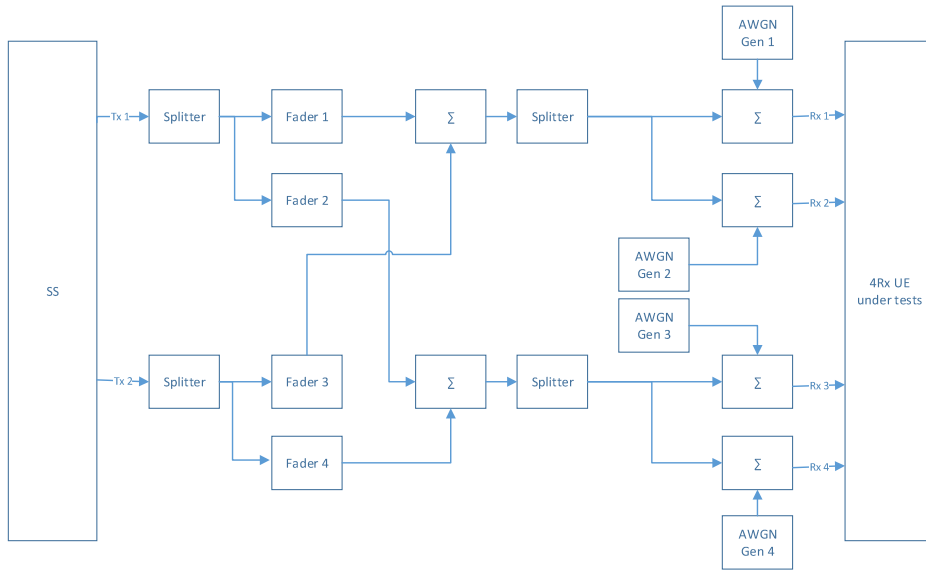

**Figure 9.1.1.4.1-1 Antenna connection example for 2Rx tests with antenna configuration as 2x2 without interference (informative)**

For 4Rx capable UEs without any 2Rx supported RF bands, for all single carrier tests listed in Table 9.1.1.4.1-1 specified from 9.2 to 9.5 with 2Rx can be skipped.

**Table 9.1.1.4.1-1 Requirement lists for 4Rx capable UEs**

Requirement lists
Enhanced performance requirements type B
Requirements with demodulation subframe overlaps with aggressor cell ABS
Requirements with demodulation subframe overlaps with aggressor cell ABS and CRS assistance information are configured

For 4Rx capable UEs, if corresponding tests listed from the 4Rx test lists from Table 9.1.1.4.1-2 are tested, the test coverage can be considered fulfilled without executing the corresponding tests listed from the 2Rx test lists from Table 9.1.1.4.1-2.

Table 9.1.1.4.1-2: Applicability rules for single carrier tests with 2Rx

4Rx test lists	2Rx test lists
9.9.1.1.1 Test 1	9.2.1.1 Test 1
9.9.1.1.1 Test 2	9.2.1.1 Test 2
9.9.1.1.2 Test 1	9.2.1.2 Test 1
9.9.1.1.2 Test 2	9.2.1.2 Test 2
9.9.1.2.1 Test 1	9.2.3.1 Test 1
9.9.1.2.1 Test 2	9.2.3.1 Test 2
9.9.1.2.2 Test 1	9.2.3.2 Test 1
9.9.1.2.2 Test 2	9.2.3.2 Test 2
9.9.2.1.1	9.3.5.1.1
9.9.2.1.2	9.3.5.1.2
9.9.2.2.1	9.3.5.2.1
9.9.2.2.2	9.3.5.2.2
9.9.3.1.1 Test 1	9.4.2.3.2 Test 1
9.9.4.1.1 Test 1	9.5.1.1 Test 1
9.9.4.1.1 Test 2	9.5.1.1 Test 2
9.9.4.1.1 Test 3	9.5.1.1 Test 3
9.9.4.1.2 Test 1	9.5.1.2 Test 1
9.9.4.1.2 Test 2	9.5.1.2 Test 2
9.9.4.1.2 Test 3	9.5.1.2 Test 3
9.9.4.2.1 Test 1	9.5.2.1 Test 1
9.9.4.2.1 Test 2	9.5.2.1 Test 2
9.9.4.2.1 Test 3	9.5.2.1 Test 3
9.9.4.2.2 Test 1	9.5.2.2 Test 1
9.9.4.2.2 Test 2	9.5.2.2 Test 2
9.9.4.2.2 Test 3	9.5.2.2 Test 3

## 9.1.1.4.2 Applicability rule and antenna connection for CA tests with 2Rx

All tests specified in 9.6 with 2Rx with CA and TDD-FDD CA are tested with 4 Rx capable UEs by connecting all 4Rx with data source from system simulator with the following change on the power level in the test configurations listed in Table 9.1.1.4.2-1 and by scheduling the PDSCH for user data based on the Reference measurement channel RC.1 FDD according to Table A.4-1 with one sided dynamic OCNG Pattern OP.1 FDD as described in Annex A.5.1.1 for FDD cells and Reference measurement channel RC.1 TDD according to Table A.4-1 with one sided dynamic OCNG Pattern OP.1 TDD as described in Annex A.5.2.1 for TDD cells.

Table 9.1.1.4.2-1: Power level for 4Rx capable UE to verify CA tests with 2Rx

Number of CCs		$\hat{I}_{or}^{(j)}$ dB[mW/15kHz]
2	PCell	-88
	SCell	-95
3,4	PCell	-85
	SCell1	-92
	SCell2, SCell3	-99
5	PCell	-85
	SCell1	-92
	SCell2, SCell3, SCell4	-99

Within the CA configuration if any of the PCell and/or the SCells is a 2Rx supported RF band, keep the same power level listed in Table 9.1.1.4.2-1. Within the CA configuration if any of the PCell and/or the SCells is a 4Rx supported RF band, configure the power level 3 dB smaller than the number listed in Table 9.1.1.4.2-1. Same requirements specified with 2Rx should be applied.

Same applicability rules defined in 9.1.1.2, 9.1.1.2A for CA and TDD-FDD CA applied for different CA configurations and bandwidth combination sets should be applied for 4 Rx capable UEs.

### 9.1.1.4.3 Applicability rule and antenna connection for single carrier tests with 4Rx

For 4Rx capable UEs all single carrier tests specified in 9.9 with 4Rx are tested on any of the 4 Rx supported RF bands by connecting all 4Rx with data source from system simulator.

### 9.1.1.5 Applicability of requirements for UEs supporting coverage enhancement

For 2Rx capable UEs supporting coverage enhancement mode A (ce-ModeA in UE-EUTRA-Capability [7]), all the tests for CE Mode A specified in 9.8.1 and 9.8.2 are tested on any of the 2Rx supported RF bands by connecting all 2Rx with data source from system simulator. The SNR requirements should be applied with 3dB less than the number specified with UE DL Category M1.

For 4Rx capable UEs supporting coverage enhancement mode A (ce-ModeA in UE-EUTRA-Capability [7]), all the tests for CE Mode A specified in 9.8.1 and 9.8.2 are tested on any of the 4Rx supported RF bands by connecting all 4Rx with data source from system simulator. The SNR requirements should be applied with 6dB less than the number specified with UE DL Category M1.

## 9.2 CQI reporting definition under AWGN conditions

The reporting accuracy of the channel quality indicator (CQI) under frequency non-selective conditions is determined by the reporting variance and the BLER performance using the transport format indicated by the reported CQI median. The purpose is to verify that the reported CQI values are in accordance with the CQI definition given in TS 36.213 [6]. To account for sensitivity of the input SNR the reporting definition is considered to be verified if the reporting accuracy is met for at least one of two SNR levels separated by an offset of 1 dB.

### 9.2.1 Minimum requirement PUCCH 1-0 (Cell-Specific Reference Symbols)

#### 9.2.1.1 FDD

The following requirements apply to UE Category  $\geq 1$ . For the parameters specified in Table 9.2.1.1-1 and Table 9.2.1.1-2, and using the downlink physical channels specified in tables C.3.2-1 and C.3.2-2, the reported CQI value according to RC.1 FDD / RC.14 FDD in Table A.4-1 shall be in the range of  $\pm 1$  of the reported median more than 90% of the time. If the PDSCH BLER using the transport format indicated by median CQI is less than or equal to 0.1, the BLER using the transport format indicated by the (median CQI + 1) shall be greater than 0.1. If the PDSCH BLER using the transport format indicated by the median CQI is greater than 0.1, the BLER using transport format indicated by (median CQI - 1) shall be less than or equal to 0.1.

The applicability of the requirement with 5MHz bandwidth as specified in Table 9.2.1.1-2 is defined in 9.1.1.1.

Table 9.2.1.1-1: PUCCH 1-0 static test (FDD)

Parameter	Unit	Test 1		Test 2	
Bandwidth	MHz	10			
PDSCH transmission mode		1			
Downlink power allocation	$\rho_A$	dB			
	$\rho_B$	dB			
	$\sigma$	dB			
Propagation condition and antenna configuration		AWGN (1 x 2)			
SNR (Note 2)	dB	0	1	6	7
$\hat{I}_{or}^{(j)}$	dB[mW/15kHz]	-98	-97	-92	-91
$N_{oc}^{(j)}$	dB[mW/15kHz]	-98		-98	
Max number of HARQ transmissions		1			
Physical channel for CQI reporting		PUCCH Format 2			
PUCCH Report Type		4			
Reporting periodicity	ms	$N_{pd} = 5$			
<i>cqi-pmi-ConfigurationIndex</i>		6			
Note 1:	Reference measurement channel RC.1 FDD according to Table A.4-1 with one sided dynamic OCNG Pattern OP.1 FDD as described in Annex A.5.1.1, except for category 1 UE use RC.4 FDD with two sided dynamic OCNG Pattern OP.2 FDD as described in Annex A.5.1.2.				
Note 2:	For each test, the minimum requirements shall be fulfilled for at least one of the two SNR(s) and the respective wanted signal input level.				

Table 9.2.1.1-2: PUCCH 1-0 static test (FDD 5MHz)

Parameter	Unit	Test 1		Test 2	
Bandwidth	MHz	5			
PDSCH transmission mode		1			
Downlink power allocation	$\rho_A$	dB			
	$\rho_B$	dB			
	$\sigma$	dB			
Propagation condition and antenna configuration		AWGN (1 x 2)			
SNR (Note 2)	dB	[0]	[1]	[6]	[7]
$\hat{I}_{or}^{(j)}$	dB[mW/15kHz]	[-98]	[-97]	[-92]	[-91]
$N_{oc}^{(j)}$	dB[mW/15kHz]	-98		-98	
Max number of HARQ transmissions		1			
Physical channel for CQI reporting		PUCCH Format 2			
PUCCH Report Type		4			
Reporting periodicity	ms	$N_{pd} = 5$			
<i>cqi-pmi-ConfigurationIndex</i>		6			
Note 1:	Reference measurement channel RC.14 FDD according to Table A.4-1 with one sided dynamic OCNG Pattern OP.1 FDD as described in Annex A.5.1.1, except for category 1 UE use RC.15 FDD with two sided dynamic OCNG Pattern OP.2 FDD as described in Annex A.5.1.2.				
Note 2:	For each test, the minimum requirements shall be fulfilled for at least one of the two SNR(s) and the respective wanted signal input level.				

### 9.2.1.2 TDD

The following requirements apply to UE Category  $\geq 1$ . For the parameters specified in Table 9.2.1.2-1, and using the downlink physical channels specified in tables C.3.2-1 and C.3.2-2, the reported CQI value according to RC.1 TDD in Table A.4-1 shall be in the range of  $\pm 1$  of the reported median more than 90% of the time. If the PDSCH BLER using

the transport format indicated by median CQI is less than or equal to 0.1, the BLER using the transport format indicated by the (median CQI + 1) shall be greater than 0.1. If the PDSCH BLER using the transport format indicated by the median CQI is greater than 0.1, the BLER using transport format indicated by (median CQI – 1) shall be less than or equal to 0.1.

Table 9.2.1.2-1: PUCCH 1-0 static test (TDD)

Parameter	Unit	Test 1		Test 2	
Bandwidth	MHz	10			
PDSCH transmission mode		1			
Uplink downlink configuration		2			
Special subframe configuration		4			
Downlink power allocation	$\rho_A$	dB		0	
	$\rho_B$	dB		0	
	$\sigma$	dB		0	
Propagation condition and antenna configuration		AWGN (1 x 2)			
SNR (Note 2)	dB	0	1	6	7
$\hat{I}_{or}^{(j)}$	dB[mW/15kHz]	-98	-97	-92	-91
$N_{oc}^{(j)}$	dB[mW/15kHz]	-98		-98	
Max number of HARQ transmissions		1			
Physical channel for CQI reporting		PUSCH (Note 3)			
PUCCH Report Type		4			
Reporting periodicity	ms	$N_{pd} = 5$			
<i>cqi-pmi-ConfigurationIndex</i>		3			
ACK/NACK feedback mode		Multiplexing			
Note 1:	Reference measurement channel RC.1 TDD according to Table A.4-1 with one sided dynamic OCNG Pattern OP.1 TDD as described in Annex A.5.2.1, except for category 1 UE use RC.4 TDD with two sided dynamic OCNG Pattern OP.2 TDD as described in Annex A.5.2.2.				
Note 2:	For each test, the minimum requirements shall be fulfilled for at least one of the two SNR(s) and the respective wanted signal input level.				
Note 3:	To avoid collisions between CQI reports and HARQ-ACK it is necessary to report both on PUSCH instead of PUCCH. PDCCH DCI format 0 shall be transmitted in downlink SF#3 and #8 to allow periodic CQI to multiplex with the HARQ-ACK on PUSCH in uplink subframe SF#7 and #2.				

### 9.2.1.3 FDD (CSI measurements in case two CSI subframe sets are configured)

The following requirements apply to UE Category  $\geq 1$ . For the parameters specified in Table 9.2.1.3-1, and using the downlink physical channels specified in tables C.3.2-1 for Cell 1, C.3.3-1 for Cell 2 and C.3.2-2, the reported CQI value according to RC.2 FDD / RC.6 FDD in Table A.4-1 in subframes overlapping with aggressor cell ABS and non-ABS subframes shall be in the range of  $\pm 1$  of the reported median more than 90% of the time. If the PDSCH BLER in non-ABS subframes using the transport format indicated by median CQI obtained by reports in CSI subframe sets  $C_{CSI,1}$  is less than or equal to 0.1, the BLER in non-ABS subframes using the transport format indicated by the (median CQI + 1) shall be greater than 0.1. If the PDSCH BLER in non-ABS subframes using the transport format indicated by the median CQI is greater than 0.1, the BLER in non-ABS subframes using transport format indicated by (median CQI – 1) shall be less than or equal to 0.1. The value of the median CQI obtained by reports in CSI subframe sets  $C_{CSI,0}$  minus the median CQI obtained by reports in CSI subframe sets  $C_{CSI,1}$  shall be larger than or equal to 2 and less than or equal to 5 in Test 1 and shall be larger than or equal to 0 and less than or equal to 1 in Test 2.

**Table 9.2.1.3-1: PUCCH 1-0 static test (FDD)**

Parameter	Unit	Test 1			Test 2		
		Cell 1	Cell 2		Cell 1	Cell 2	
Bandwidth	MHz	10			10		
PD SCH transmission mode		2	Note 10		2	Note 10	
Downlink power allocation	$\rho_A$	-3			-3		
	$\rho_B$	-3			-3		
	$\sigma$	0			0		
Propagation condition and antenna configuration		Clause B.1 (2x2)			Clause B.1 (2x2)		
$E_s/N_{oc2}$ (Note 1)	dB	4	5	6	4	5	-12
$N_{oc}^{(j)}$ at antenna port	$N_{oc1}^{(j)}$	-102 (Note 7)		N/A	-98 (Note 7)		N/A
	$N_{oc2}^{(j)}$	-98 (Note 8)		N/A	-98 (Note 8)		N/A
	$N_{oc3}^{(j)}$	-94.8 (Note 9)		N/A	-98 (Note 9)		N/A
$\hat{I}_{or}^{(j)}$	dB[mW/15kHz]	-94	-93	-92	-94	-93	-110
Subframe Configuration		Non-MBSFN		Non-MBSFN	Non-MBSFN		Non-MBSFN
Cell Id		0		1	0		1
Time Offset between Cells	$\mu$ s	2.5 (synchronous cells)			2.5 (synchronous cells)		
ABS pattern (Note 2)		N/A		01010101 01010101 01010101 01010101 01010101	N/A		01010101 01010101 01010101 01010101 01010101
RLM/RRM Measurement Subframe Pattern (Note 4)		00000100 00000100 00000100 00000100 00000100		N/A	00000100 00000100 00000100 00000100 00000100		N/A
CSI Subframe Sets (Note 3)	$C_{CSI,0}$	01010101 01010101 01010101 01010101 01010101		N/A	01010101 01010101 01010101 01010101 01010101		N/A
	$C_{CSI,1}$	10101010 10101010 10101010 10101010 10101010		N/A	10101010 10101010 10101010 10101010 10101010		N/A
Number of control OFDM symbols		3			3		
Max number of HARQ transmissions		1			1		
Physical channel for $C_{CSI,0}$ CQI reporting		PUCCH Format 2			PUCCH Format 2		
Physical channel for $C_{CSI,1}$ CQI reporting		PUSCH (Note 12)			PUSCH (Note 12)		
PUCCH Report Type		4			4		
Reporting periodicity	Ms	$N_{pd} = 5$			$N_{pd} = 5$		
$cqi-pmi-ConfigurationIndex_{C_{CSI,0}}$ (Note 13)		6	N/A		6	N/A	
$cqi-pmi-ConfigurationIndex2_{C_{CSI,1}}$ (Note 14)		5	N/A		5	N/A	



Note 1:	For each test, the minimum requirements shall be fulfilled for at least one of the two SNR(s) and the respective wanted signal input level.
Note 2:	ABS pattern as defined in [9].
Note 3:	Time-domain measurement resource restriction pattern for PCell measurements as defined in [7]
Note 4:	As configured according to the time-domain measurement resource restriction pattern for CSI measurements defined in [7]
Note 5:	Time-domain measurement resource restriction pattern for PCell measurements as defined in [7]
Note 6:	Cell 1 is the serving cell. Cell 2 is the aggressor cell. The number of the CRS ports in Cell1 and Cell2 is the same.
Note 7:	This noise is applied in OFDM symbols #1, #2, #3, #5, #6, #8, #9, #10, #12, #13 of a subframe overlapping with the aggressor ABS.
Note 8:	This noise is applied in OFDM symbols #0, #4, #7, #11 of a subframe overlapping with the aggressor ABS.
Note 9:	This noise is applied in all OFDM symbols of a subframe overlapping with aggressor non-ABS.
Note 10:	Downlink physical channel setup in Cell 2 in accordance with Annex C.3.3 applying OCNG pattern as defined in Annex A.5.1.5
Note 11:	Reference measurement channel in Cell 1 RC.2 FDD according to Table A.4-1 for UE Category 2-8 with one sided dynamic OCNG Pattern OP.1 FDD as described in Annex A.5.1.1, and RC.6 FDD according to Table A.4-1 for Category 1 with one/two sided dynamic OCNG Pattern OP. 1/2 FDD as described in Annex A.5.1.1 and A.5.1.2.
Note 12:	To avoid collisions between HARQ-ACK and wideband CQI it is necessary to report both on PUSCH instead of PUCCH. PDCCH DCI format 0 shall be transmitted in downlink SF#4 and #9 to allow periodic CQI to multiplex with the HARQ-ACK on PUSCH in uplink subframe SF#8 and #3.
Note 13:	<i>cqi-pmi-ConfigurationIndex</i> is applied for $C_{CSI,0}$ .
Note 14:	<i>cqi-pmi-ConfigurationIndex2</i> is applied for $C_{CSI,1}$ .

#### 9.2.1.4 TDD (CSI measurements in case two CSI subframe sets are configured)

The following requirements apply to UE Category  $\geq 1$ . For the parameters specified in Table 9.2.1.4-1, and using the downlink physical channels specified in tables C.3.2-1 for Cell 1, C.3.3-1 for Cell 2 and C.3.2-2, the reported CQI value according to RC.2 TDD / RC.6 TDD in Table A.4-1 in subframes overlapping with aggressor cell ABS and non-ABS subframes shall be in the range of  $\pm 1$  of the reported median more than 90% of the time. If the PDSCH BLER in non-ABS subframes using the transport format indicated by median CQI obtained by reports in CSI subframe sets  $C_{CSI,1}$  is less than or equal to 0.1, the BLER in non-ABS subframes using the transport format indicated by the (median CQI + 1) shall be greater than 0.1. If the PDSCH BLER in non-ABS subframes using the transport format indicated by the median CQI is greater than 0.1, the BLER in non-ABS subframes using transport format indicated by (median CQI - 1) shall be less than or equal to 0.1. The value of the median CQI obtained by reports in CSI subframe sets  $C_{CSI,0}$  minus the median CQI obtained by reports in CSI subframe sets  $C_{CSI,1}$  shall be larger than or equal to 2 and less than or equal to 5 in Test 1 and shall be larger than or equal to 0 and less than or equal to 1 in Test 2.

**Table 9.2.1.4-1: PUCCH 1-0 static test (TDD)**

Parameter	Unit	Test 1			Test 2			
		Cell 1	Cell 2		Cell 1	Cell 2		
Bandwidth	MHz	10			10			
PDSCH transmission mode		2	Note 10		2	Note 10		
Uplink downlink configuration		1			1			
Special subframe configuration		4			4			
Downlink power allocation	$\rho_A$	dB			-3			
	$\rho_B$	dB			-3			
	$\sigma$	dB			0			
Propagation condition and antenna configuration		Clause B.1 (2x2)			Clause B.1 (2x2)			
$E_s/N_{oc2}$ (Note 1)	dB	4	5	6	4	5	-12	
$N_{oc}^{(j)}$ at antenna port	$N_{oc1}^{(j)}$	dBm/15kHz		-102 (Note 7)	N/A		-98 (Note 7)	N/A
	$N_{oc2}^{(j)}$	dBm/15kHz		-98 (Note 8)	N/A		-98 (Note 8)	N/A
	$N_{oc3}^{(j)}$	dBm/15kHz		-94.8 (Note 9)	N/A		-98 (Note 9)	N/A
$\hat{I}_{or}^{(j)}$	dB[mW/15kHz]	-94	-93	-92	-94	-93	-110	
Subframe Configuration		Non-MBSFN		Non-MBSFN	Non-MBSFN		Non-MBSFN	
Cell Id		0		1	0		1	
Time Offset between Cells	$\mu$ s	2.5 (synchronous cells)			2.5 (synchronous cells)			
ABS pattern (Note 2)		N/A		0100010001 0100010001	N/A		0100010001 0100010001	
RLM/RRM Measurement Subframe Pattern (Note 4)		0000000001 0000000001		N/A	0000000001 0000000001		N/A	
CSI Subframe Sets (Note 3)	$C_{CSI,0}$	0100010001 0100010001		N/A	0100010001 0100010001		N/A	
	$C_{CSI,1}$	1000101000 1000101000		N/A	1000101000 1000101000		N/A	
Number of control OFDM symbols		3			3			
Max number of HARQ transmissions		1			1			
Physical channel for $C_{CSI,0}$ CQI reporting		PUCCH Format 2			PUCCH Format 2			
Physical channel for $C_{CSI,1}$ CQI reporting		PUSCH (Note 12)			PUSCH			
PUCCH Report Type		4			4			
Reporting periodicity	ms	$N_{pd} = 5$			$N_{pd} = 5$			
$cqi-pmi-ConfigurationIndex_{CSI,0}$ (Note 13)		3	N/A		3	N/A		
$cqi-pmi-ConfigurationIndex2_{CSI,1}$ (Note 14)		4	N/A		4	N/A		
ACK/NACK feedback mode		Multiplexing			Multiplexing			

Note 1:	For each test, the minimum requirements shall be fulfilled for at least one of the two SNR(s) and the respective wanted signal input level.
Note 2:	ABS pattern as defined in [9].
Note 3:	Time-domain measurement resource restriction pattern for PCell measurements as defined in [7]
Note 4:	As configured according to the time-domain measurement resource restriction pattern for CSI measurements defined in [7].
Note 5:	Time-domain measurement resource restriction pattern for PCell measurements as defined in [7]
Note 6:	Cell 1 is the serving cell. Cell 2 is the aggressor cell. The number of the CRS ports in Cell1 and Cell2 is the same.
Note 7:	This noise is applied in OFDM symbols #1, #2, #3, #5, #6, #8, #9, #10, #12, #13 of a subframe overlapping with the aggressor ABS.
Note 8:	This noise is applied in OFDM symbols #0, #4, #7, #11 of a subframe overlapping with the aggressor ABS
Note 9:	This noise is applied in all OFDM symbols of a subframe overlapping with aggressor non-ABS.
Note 10:	Downlink physical channel setup in Cell 2 in accordance with Annex C.3.3 applying OCNG pattern as defined in Annex A.5.2.5
Note 11:	Reference measurement channel in Cell 1 RC.2 TDD according to Table A.4-1 for UE Category $\geq 2$ with one sided dynamic OCNG Pattern OP.1 TDD as described in Annex A.5.2.1, and RC.6 TDD according to Table A.4-1 for Category 1 with one/two sided dynamic OCNG Pattern OP.1/2 TDD as described in Annex A.5.2.1 and Annex A.5.2.2.
Note 12:	To avoid collisions between HARQ-ACK and wideband CQI it is necessary to report both on PUSCH instead of PUCCH. PDCCH DCI format 0 shall be transmitted in downlink SF#4 and #9 to allow periodic CQI to multiplex with the HARQ-ACK on PUSCH in uplink subframe SF#8 and #3.
Note 13:	<i>cqi-pmi-ConfigurationIndex</i> is applied for $C_{CSI,0}$ .
Note 14:	<i>cqi-pmi-ConfigurationIndex2</i> is applied for $C_{CSI,1}$ .

### 9.2.1.5 FDD (CSI measurements in case two CSI subframe sets are configured and with CRS assistance information)

The following requirements apply to UE Category  $\geq 2$ . For the parameters specified in Table 9.2.1.5-1, and using the downlink physical channels specified in tables C.3.2-1 for Cell 1, C.3.3-2 for Cell 2 and Cell 3, and C.3.2-2, the reported CQI value according to RC.2 FDD in Table A.4-1 in subframes overlapping with aggressor cell ABS and non-ABS subframes shall be in the range of  $\pm 1$  of the reported median more than 90% of the time.

For test 1 and test 2, if the PDSCH BLER in ABS subframes using the transport format indicated by median CQI obtained by reports in CSI subframe sets  $C_{CSI,0}$  is less than or equal to 0.1, the BLER in ABS subframes using the transport format indicated by the (median CQI + 1) shall be greater than 0.1. If the PDSCH BLER in ABS subframes using the transport format indicated by the median CQI is greater than 0.1, the BLER in ABS subframes using transport format indicated by (median CQI – 1) shall be less than or equal to 0.1.

For test 2, if the PDSCH BLER in non-ABS subframes using the transport format indicated by median CQI obtained by reports in CSI subframe sets  $C_{CSI,1}$  is less than or equal to 0.1, the BLER in non-ABS subframes using the transport format indicated by the (median CQI + 2) shall be greater than 0.1. If the PDSCH BLER in non-ABS subframes using the transport format indicated by the median CQI is greater than 0.1, the BLER in non-ABS subframes using transport format indicated by (median CQI – 1) shall be less than or equal to 0.1.

**Table 9.2.1.5-1: PUCCH 1-0 static test (FDD)**

Parameter	Unit	Test 1			Test 2		
		Cell 1	Cell 2 and 3		Cell 1	Cell 2 and 3	
Bandwidth	MHz	10			10		
PDSCH transmission mode		2	Note 10		2	Note 10	
Downlink power allocation	$\rho_A$	-3			-3		
	$\rho_B$	-3			-3		
	$\sigma$	0			0		
Propagation condition and antenna configuration		Clause B.1 (2x2)			Clause B.1 (2x2)		
$E_s/N_{oc2}$ (Note 1)	dB	4	5	Cell 2: 12 Cell 3: 10	13	14	Cell 2: 12 Cell 3: 10
$N_{oc}^{(j)}$ at antenna port	$N_{oc1}^{(j)}$	-98 (Note 7)		N/A	-98 (Note 7)		N/A
	$N_{oc2}^{(j)}$	-98 (Note 8)		N/A	-98 (Note 8)		N/A
	$N_{oc3}^{(j)}$	-93 (Note 9)		N/A	-93 (Note 9)		N/A
Subframe Configuration		Non-MBSFN	Non-MBSFN	Non-MBSFN	Non-MBSFN		Non-MBSFN
Cell Id		0	Cell 2: 6 Cell 3: 1	0	Cell 2: 6 Cell 3: 1		
Time Offset between Cells	$\mu$ s	Cell 2: 3 usec Cell 3: -1usec		Cell 2: 3 usec Cell 3: -1usec			
Frequency Shift between Cells	Hz	Cell 2: 300Hz Cell 3: -100Hz		Cell 2: 300Hz Cell 3: -100Hz			
ABS pattern (Note 2)		N/A	01010101 01010101 01010101 01010101 01010101	N/A	01010101 01010101 01010101 01010101 01010101		
RLM/RRM Measurement Subframe Pattern (Note 4)		00000100 00000100 00000100 00000100 00000100	N/A	00000100 00000100 00000100 00000100 00000100	N/A		
CSI Subframe Sets (Note 3)	$C_{CSI,0}$	01010101 01010101 01010101 01010101 01010101	N/A	01010101 01010101 01010101 01010101 01010101	N/A		
	$C_{CSI,1}$	10101010 10101010 10101010 10101010 10101010	N/A	10101010 10101010 10101010 10101010 10101010	N/A		
Number of control OFDM symbols		3			3		
Max number of HARQ transmissions		1			1		
Physical channel for $C_{CSI,0}$ CQI reporting		PUCCH Format 2			PUCCH Format 2		
Physical channel for $C_{CSI,1}$ CQI reporting		PUSCH (Note 12)			PUSCH (Note 12)		
PUCCH Report Type		4			4		
Reporting periodicity	Ms	$N_{pd} = 5$			$N_{pd} = 5$		
$cqi-pmi-ConfigurationIndex_{C_{CSI,0}}$ (Note 13)		6	N/A		6	N/A	
$cqi-pmi-ConfigurationIndex2_{C_{CSI,1}}$ (Note 14)		5	N/A		5	N/A	

Note 1:	For each test, the minimum requirements shall be fulfilled for at least one of the two SNR(s) and the respective wanted signal input level.
Note 2:	ABS pattern as defined in [9].
Note 3:	Time-domain measurement resource restriction pattern for PCell measurements as defined in [7]
Note 4:	As configured according to the time-domain measurement resource restriction pattern for CSI measurements defined in [7]
Note 5:	Time-domain measurement resource restriction pattern for PCell measurements as defined in [7]
Note 6:	Cell 1 is the serving cell. Cell 2 and Cell 3 are the aggressor cells. The number of the CRS ports in Cell1, Cell2, and Cell3 are the same.
Note 7:	This noise is applied in OFDM symbols #1, #2, #3, #5, #6, #8, #9, #10, #12, #13 of a subframe overlapping with the aggressor ABS.
Note 8:	This noise is applied in OFDM symbols #0, #4, #7, #11 of a subframe overlapping with the aggressor ABS.
Note 9:	This noise is applied in all OFDM symbols of a subframe overlapping with aggressor non-ABS.
Note 10:	Downlink physical channel setup in Cell 2 and Cell 3 in accordance with Annex C.3.3 applying OCNG pattern as defined in Annex A.5.1.5
Note 11:	Reference measurement channel in Cell 1 RC.2 FDD according to Table A.4-1 with one sided dynamic OCNG Pattern OP.1 FDD as described in Annex A.5.1.1.
Note 12:	To avoid collisions between HARQ-ACK and wideband CQI it is necessary to report both on PUSCH instead of PUCCH. PDCCH DCI format 0 shall be transmitted in downlink SF#4 and #9 to allow periodic CQI to multiplex with the HARQ-ACK on PUSCH in uplink subframe SF#8 and #3.
Note 13:	<i>cqi-pmi-ConfigurationIndex</i> is applied for $C_{CSI,0}$ .
Note 14:	<i>cqi-pmi-ConfigurationIndex2</i> is applied for $C_{CSI,1}$ .

### 9.2.1.6 TDD (CSI measurements in case two CSI subframe sets are configured and with CRS assistance information)

The following requirements apply to UE Category  $\geq 2$ . For the parameters specified in Table 9.2.1.6-1, and using the downlink physical channels specified in tables C.3.2-1 for Cell 1, C.3.2-2 for Cell 2 and Cell 3, and C.3.2-2, the reported CQI value according to RC.2 TDD in Table A.4-1 in subframes overlapping with aggressor cell ABS and non-ABS subframes shall be in the range of  $\pm 1$  of the reported median more than 90% of the time.

For test 1 and test 2, if the PDSCH BLER in ABS subframes using the transport format indicated by median CQI obtained by reports in CSI subframe sets  $C_{CSI,0}$  is less than or equal to 0.1, the BLER in ABS subframes using the transport format indicated by the (median CQI + 1) shall be greater than 0.1. If the PDSCH BLER in ABS subframes using the transport format indicated by the median CQI is greater than 0.1, the BLER in ABS subframes using transport format indicated by (median CQI – 1) shall be less than or equal to 0.1.

For test 2, if the PDSCH BLER in non-ABS subframes using the transport format indicated by median CQI obtained by reports in CSI subframe sets  $C_{CSI,1}$  is less than or equal to 0.1, the BLER in non-ABS subframes using the transport format indicated by the (median CQI + 2) shall be greater than 0.1. If the PDSCH BLER in non-ABS subframes using the transport format indicated by the median CQI is greater than 0.1, the BLER in non-ABS subframes using transport format indicated by (median CQI – 1) shall be less than or equal to 0.1.

**Table 9.2.1.6-1: PUCCH 1-0 static test (TDD)**



Parameter	Unit	Test 1			Test 2		
		Cell 1	Cell 2 and 3		Cell 1	Cell 2 and 3	
Bandwidth	MHz	10			10		
PDSCH transmission mode		2	Note 10		2	Note 10	
Uplink downlink configuration		1			1		
Special subframe configuration		4			4		
Downlink power allocation	$\rho_A$	dB			-3		
	$\rho_B$	dB			-3		
	$\sigma$	dB			0		
Propagation condition and antenna configuration		Clause B.1 (2x2)			Clause B.1 (2x2)		
$E_s/N_{oc2}$ (Note 1)	dB	4	5	Cell 2: 12 Cell 3: 10	13	14	Cell 2: 12 Cell 3: 10
$N_{oc}^{(j)}$ at antenna port	$N_{oc1}^{(j)}$	dBm/15kHz		-98 (Note 7)	N/A		-98 (Note 7)
	$N_{oc2}^{(j)}$	dBm/15kHz		-98 (Note 8)	N/A		-98 (Note 8)
	$N_{oc3}^{(j)}$	dBm/15kHz		-93 (Note 9)	N/A		-93 (Note 9)
Subframe Configuration		Non-MBSFN		Non-MBSFN	Non-MBSFN		Non-MBSFN
Cell Id		0		Cell 2: 6 Cell 3: 1	0		Cell 2: 6 Cell 3: 1
Time Offset between Cells	$\mu$ s	Cell 2: 3 usec Cell 3: -1usec			Cell 2: 3 usec Cell 3: -1usec		
Frequency shift between Cells	Hz	Cell 2: 300Hz Cell 3: -100Hz			Cell 2: 300Hz Cell 3: -100Hz		
ABS pattern (Note 2)		N/A		0100010001 0100010001	N/A		0100010001 0100010001
RLM/RRM Measurement Subframe Pattern (Note 4)		0000000001 0000000001		N/A		0000000001 0000000001	
CSI Subframe Sets (Note 3)	$C_{CSI,0}$	0100010001 0100010001		N/A		0100010001 0100010001	
	$C_{CSI,1}$	1000101000 1000101000		N/A		1000101000 1000101000	
Number of control OFDM symbols		3			3		
Max number of HARQ transmissions		1			1		
Physical channel for $C_{CSI,0}$ CQI reporting		PUCCH Format 2			PUCCH Format 2		
Physical channel for $C_{CSI,1}$ CQI reporting		PUSCH (Note 12)			PUSCH (Note 12)		
PUCCH Report Type		4			4		
Reporting periodicity	ms	$N_{pd} = 5$			$N_{pd} = 5$		
$cqi-pmi-ConfigurationIndex$ $C_{CSI,0}$ (Note 13)		3	N/A		3	N/A	
$cqi-pmi-ConfigurationIndex2$ $C_{CSI,1}$ (Note 14)		4	N/A		4	N/A	
ACK/NACK feedback mode		Multiplexing			Multiplexing		

Note 1:	For each test, the minimum requirements shall be fulfilled for at least one of the two SNR(s) and the respective wanted signal input level.
Note 2:	ABS pattern as defined in [9].
Note 3:	Time-domain measurement resource restriction pattern for PCell measurements as defined in [7]
Note 4:	As configured according to the time-domain measurement resource restriction pattern for CSI measurements defined in [7].
Note 5:	Time-domain measurement resource restriction pattern for PCell measurements as defined in [7]
Note 6:	Cell 1 is the serving cell. Cell 2 and Cell 3 are the aggressor cells. The number of the CRS ports in Cell1, Cell2, and Cell3 is the same.
Note 7:	This noise is applied in OFDM symbols #1, #2, #3, #5, #6, #8, #9, #10, #12, #13 of a subframe overlapping with the aggressor ABS.
Note 8:	This noise is applied in OFDM symbols #0, #4, #7, #11 of a subframe overlapping with the aggressor ABS
Note 9:	This noise is applied in all OFDM symbols of a subframe overlapping with aggressor non-ABS.
Note 10:	Downlink physical channel setup in Cell 2 and Cell 3 in accordance with Annex C.3.3 applying OCNG pattern as defined in Annex A.5.2.5
Note 11:	Reference measurement channel in Cell 1 RC.2 TDD according to Table A.4-1 with one sided dynamic OCNG Pattern OP.1 TDD as described in Annex A.5.2.1.
Note 12:	To avoid collisions between HARQ-ACK and wideband CQI it is necessary to report both on PUSCH instead of PUCCH. PDCCH DCI format 0 shall be transmitted in downlink SF#4 and #9 to allow periodic CQI to multiplex with the HARQ-ACK on PUSCH in uplink subframe SF#8 and #3.
Note 13:	<i>cqi-pmi-ConfigurationIndex</i> is applied for $C_{CSI,0}$ .
Note 14:	<i>cqi-pmi-ConfigurationIndex2</i> is applied for $C_{CSI,1}$ .

### 9.2.1.7 FDD (Modulation and TBS index Table 2 and 4-bit CQI Table 2 are used)

The following requirements apply to UE Category 11-12 and DL Category  $\geq 11$ . For the parameters specified in Table 9.2.1.7-1, and using the downlink physical channels specified in tables C.3.2-1 and C.3.2-2, the reported CQI value according to RC.1A FDD in Table A.4-1 shall be in the range of  $\pm 1$  of the reported median more than 90% of the time. If the PDSCH BLER using the transport format indicated by median CQI is less than or equal to 0.1, the BLER using the transport format indicated by the (median CQI + 1) shall be greater than 0.1, or the BLER using the transport format indicated by the (median CQI - 1) shall be less than or equal to 0.1 when the highest MCS value of the test case has reached. If the PDSCH BLER using the transport format indicated by the median CQI is greater than 0.1, the BLER using transport format indicated by (median CQI - 1) shall be less than or equal to 0.1.

In this test, 4-bit CQI Table 2 in Table 7.2.3-2 in TS 36.213 [6], and Modulation and TBS index table 2 in Table 7.1.7.1-1A for PDSCH in TS 36.213 [6] are applied.

**Table 9.2.1.7-1: PUCCH 1-0 static test (FDD)**

Parameter	Unit	Test 1		Test 2	
Bandwidth	MHz	10			
PDSCH transmission mode		1			
Downlink power allocation	$\rho_A$	0			
	$\rho_B$	0			
	$\sigma$	0			
Propagation condition and antenna configuration		AWGN (1 x 2)			
SNR (Note 2)	dB	-1	0	20	21
$\hat{I}_{or}^{(j)}$	dB[mW/15kHz]	-99	-98	-78	-77
$N_{oc}^{(j)}$	dB[mW/15kHz]	-98		-98	
Max number of HARQ transmissions		1			
Physical channel for CQI reporting		PUCCH Format 2			
PUCCH Report Type		4			
Reporting periodicity	ms	$N_{pd} = 5$			
<i>cqi-pmi-ConfigurationIndex</i>		6			
Note 1:	Reference measurement channel RC.1A FDD according to Table A.4-1 with one sided dynamic OCNG Pattern OP.1 FDD as described in Annex A.5.1.1.				
Note 2:	For each test, the minimum requirements shall be fulfilled for at least one of the two SNR(s) and the respective wanted signal input level.				

### 9.2.1.8 TDD (Modulation and TBS index Table 2 and 4-bit CQI Table 2 are used)

The following requirements apply to UE Category 11-12 and UE DL Category  $\geq 11$ . For the parameters specified in Table 9.2.1.8-1, and using the downlink physical channels specified in tables C.3.2-1 and C.3.2-2, the reported CQI value according to RC.1A TDD in Table A.4-1 shall be in the range of  $\pm 1$  of the reported median more than 90% of the time. If the PDSCH BLER using the transport format indicated by median CQI is less than or equal to 0.1, the BLER using the transport format indicated by the (median CQI + 1) shall be greater than 0.1, or the BLER using the transport format indicated by the (median CQI - 1) shall be less than or equal to 0.1 when the highest MCS value of the test case has reached. If the PDSCH BLER using the transport format indicated by the median CQI is greater than 0.1, the BLER using transport format indicated by (median CQI - 1) shall be less than or equal to 0.1.

In this test, 4-bit CQI Table 2 in Table 7.2.3-2 in TS 36.213 [6], and Modulation and TBS index table 2 in Table 7.1.7.1-1A for PDSCH in TS 36.213 [6] are applied.

**Table 9.2.1.8-1: PUCCH 1-0 static test (TDD)**

Parameter		Unit	Test 1		Test 2	
Bandwidth		MHz	20			
PDSCH transmission mode			1			
Uplink downlink configuration			2			
Special subframe configuration			4			
Downlink power allocation	$\rho_A$	dB	0			
	$\rho_B$	dB	0			
	$\sigma$	dB	0			
Propagation condition and antenna configuration			AWGN (1 x 2)			
SNR (Note 2)		dB	-1	0	20	21
$\hat{I}_{or}^{(j)}$		dB[mW/15kHz]	-99	-98	-78	-77
$N_{OC}^{(j)}$		dB[mW/15kHz]	-98		-98	
Max number of HARQ transmissions			1			
Physical channel for CQI reporting			PUSCH (Note 3)			
PUCCH Report Type			4			
Reporting periodicity		ms	$N_{pd} = 5$			
cqi-pmi-ConfigurationIndex			3			
ACK/NACK feedback mode			Multiplexing			
Note 1: Reference measurement channel RC.1A TDD according to Table A.4-1 with one sided dynamic OCN Pattern OP.1 TDD as described in Annex A.5.2.1.						
Note 2: For each test, the minimum requirements shall be fulfilled for at least one of the two SNR(s) and the respective wanted signal input level.						
Note 3: To avoid collisions between CQI reports and HARQ-ACK it is necessary to report both on PUSCH instead of PUCCH. PDCCH DCI format 0 shall be transmitted in downlink SF#3 and #8 to allow periodic CQI to multiplex with the HARQ-ACK on PUSCH in uplink subframe SF#7 and #2.						

### 9.2.1.9 FDD (Modulation and TBS index Table 3 and 4-bit CQI Table 4 are used)

The following requirements apply to UE DL Category 20 and DL Category  $\geq 22$ . For the parameters specified in Table 9.2.1.9-1, and using the downlink physical channels specified in tables C.3.2-1 and C.3.2-2, the reported CQI value according to RC.X FDD in Table A.4-1 shall be in the range of  $\pm 1$  of the reported median more than 90% of the time. If the PDSCH BLER using the transport format indicated by median CQI is less than or equal to 0.1, the BLER using the transport format indicated by the (median CQI + 1) shall be greater than 0.1. If the PDSCH BLER using the transport format indicated by the median CQI is greater than 0.1, the BLER using transport format indicated by (median CQI - 1) shall be less than or equal to 0.1.

In this test, 4-bit CQI Table 4 in Table 7.2.3-4 in TS 36.213 [6], and Modulation and TBS index table 3 in Table 7.1.7.1-1B for PDSCH in TS 36.213 [6] are applied.

Table 9.2.1.9-1: PUCCH 1-0 static test (FDD)

Parameter	Unit	Test 1	
Bandwidth	MHz	10	
PDSCH transmission mode		1	
Downlink power allocation	$\rho_A$	0	
	$\rho_B$	0	
	$\sigma$	0	
Propagation condition and antenna configuration		AWGN (1 x 2)	
SNR (Note 2)	dB	28	29
$\hat{I}_{or}^{(j)}$	dB[mW/15kHz]	-70	-69
$N_{oc}^{(j)}$	dB[mW/15kHz]	-98	
Max number of HARQ transmissions		1	
Physical channel for CQI reporting		PUCCH Format 2	
PUCCH Report Type		4	
Reporting periodicity	ms	$N_{pd} = 5$	
<i>cqi-pmi-ConfigurationIndex</i>		6	
Note 1:	Reference measurement channel RC.30 FDD according to Table A.4-1 with one sided dynamic OCNG Pattern OP.1 FDD as described in Annex A.5.1.1.		
Note 2:	For each test, the minimum requirements shall be fulfilled for at least one of the two SNR(s) and the respective wanted signal input level.		

### 9.2.1.10 TDD (Modulation and TBS index Table 3 and 4-bit CQI Table 4 are used)

The following requirements apply to UE DL Category 20 and DL Category  $\geq 22$ . For the parameters specified in Table 9.2.1.10-1, and using the downlink physical channels specified in tables C.3.2-1 and C.3.2-2, the reported CQI value according to RC.X TDD in Table A.4-1 shall be in the range of  $\pm 1$  of the reported median more than 90% of the time. If the PDSCH BLER using the transport format indicated by median CQI is less than or equal to 0.1, the BLER using the transport format indicated by the (median CQI + 1) shall be greater than 0.1. If the PDSCH BLER using the transport format indicated by the median CQI is greater than 0.1, the BLER using transport format indicated by (median CQI – 1) shall be less than or equal to 0.1.

In this test, 4-bit CQI Table 3 in Table 7.2.3-4 in TS 36.213 [6], and Modulation and TBS index table 3 in Table 7.1.7.1-1B for PDSCH in TS 36.213 [6] are applied.

Table 9.2.1.10-1: PUCCH 1-0 static test (TDD)

Parameter		Unit	Test 1	
Bandwidth		MHz	20	
PDSCH transmission mode			1	
Uplink downlink configuration			2	
Special subframe configuration			4	
Downlink power allocation	$\rho_A$	dB	0	
	$\rho_B$	dB	0	
	$\sigma$	dB	0	
Propagation condition and antenna configuration			AWGN (1 x 2)	
SNR (Note 2)		dB	28	29
$\hat{I}_{or}^{(j)}$		dB[mW/15kHz]	-70	-69
$N_{oc}^{(j)}$		dB[mW/15kHz]	-98	
Max number of HARQ transmissions			1	
Physical channel for CQI reporting			PUSCH (Note 3)	
PUCCH Report Type			4	
Reporting periodicity		ms	$N_{pd} = 5$	
<i>cqi-pmi-ConfigurationIndex</i>			3	
ACK/NACK feedback mode			Multiplexing	
<p>Note 1: Reference measurement channel RC.30 TDD according to Table A.4-1 with one sided dynamic OCNG Pattern OP.1 TDD as described in Annex A.5.2.1.</p> <p>Note 2: For each test, the minimum requirements shall be fulfilled for at least one of the two SNR(s) and the respective wanted signal input level.</p> <p>Note 3: To avoid collisions between CQI reports and HARQ-ACK it is necessary to report both on PUSCH instead of PUCCH. PDCCH DCI format 0 shall be transmitted in downlink SF#3 and #8 to allow periodic CQI to multiplex with the HARQ-ACK on PUSCH in uplink subframe SF#7 and #2.</p>				

## 9.2.2 Minimum requirement PUCCH 1-1 (Cell-Specific Reference Symbols)

The minimum requirements for dual codeword transmission are defined in terms of a reporting spread of the wideband CQI value for codeword #1, and their BLER performance using the transport format indicated by the reported CQI median of codeword #0 and codeword #1. The precoding used at the transmitter is a fixed precoding matrix specified by the bitmap parameter *codebookSubsetRestriction*. The propagation condition assumed for the minimum performance requirement is defined in subclause B.1.

### 9.2.2.1 FDD

The following requirements apply to UE Category  $\geq 2$ . For the parameters specified in table 9.2.2.1-1, and using the downlink physical channels specified in tables C.3.2-1 and C.3.2-2, the reported offset level of the wideband spatial differential CQI for codeword #1 (Table 7.2-2 in TS 36.213 [6]) shall be used to determine the wideband CQI index for codeword #1 as

$$\text{wideband CQI}_1 = \text{wideband CQI}_0 - \text{Codeword 1 offset level}$$

The wideband CQI<sub>1</sub> shall be within the set {median CQI<sub>1</sub> -1, median CQI<sub>1</sub>, median CQI<sub>1</sub> +1} for more than 90% of the time, where the resulting wideband values CQI<sub>1</sub> shall be used to determine the median CQI values for codeword #1. For both codewords #0 and #1, the PDSCH BLER using the transport format indicated by the respective median CQI<sub>0</sub> - 1 and median CQI<sub>1</sub> - 1 shall be less than or equal to 0.1. Furthermore, for both codewords #0 and #1, the PDSCH BLER using the transport format indicated by the respective median CQI<sub>0</sub> + 1 and median CQI<sub>1</sub> + 1 shall be greater than or equal to 0.1.

Table 9.2.2.1-1: PUCCH 1-1 static test (FDD)

Parameter	Unit	Test 1		Test 2	
Bandwidth	MHz	10			
PDSCH transmission mode		4			
Downlink power allocation	$\rho_A$	dB			
	$\rho_B$	dB			
	$\sigma$	dB			
Propagation condition and antenna configuration		Clause B.1 (2 x 2)			
CodeBookSubsetRestriction bitmap		010000			
SNR (Note 2)	dB	10	11	16	17
$\hat{I}_{or}^{(j)}$	dB[mW/15kHz]	-88	-87	-82	-81
$N_{oc}^{(j)}$	dB[mW/15kHz]	-98		-98	
Max number of HARQ transmissions		1			
Physical channel for CQI/PMI reporting		PUCCH Format 2			
PUCCH Report Type for CQI/PMI		2			
PUCCH Report Type for RI		3			
Reporting periodicity	ms	$N_{pd} = 5$			
<i>cqi-pmi-ConfigurationIndex</i>		6			
<i>ri-ConfigIndex</i>		1 (Note 3)			
Note 1:	Reference measurement channel RC.2 FDD according to Table A.4-1 with one sided dynamic OCNG Pattern OP.1 FDD as described in Annex A.5.1.1.				
Note 2:	For each test, the minimum requirements shall be fulfilled for at least one of the two SNR(s) and the respective wanted signal input level.				
Note 3:	It is intended to have UL collisions between RI reports and HARQ-ACK, since the RI reports shall not be used by the eNB in this test.				

### 9.2.2.2 TDD

The following requirements apply to UE Category  $\geq 2$ . For the parameters specified in table 9.2.2.2-1, and using the downlink physical channels specified in tables C.3.2-1 and C.3.2-2, the reported offset level of the wideband spatial differential CQI for codeword #1 (Table 7.2-2 in TS 36.213 [6]) shall be used to determine the wideband CQI index for codeword #1 as

$$\text{wideband CQI}_1 = \text{wideband CQI}_0 - \text{Codeword 1 offset level}$$

The wideband CQI<sub>1</sub> shall be within the set {median CQI<sub>1</sub> -1, median CQI<sub>1</sub>, median CQI<sub>1</sub> +1} for more than 90% of the time, where the resulting wideband values CQI<sub>1</sub> shall be used to determine the median CQI values for codeword #1. For both codewords #0 and #1, the PDSCH BLER using the transport format indicated by the respective median CQI<sub>0</sub> - 1 and median CQI<sub>1</sub> - 1 shall be less than or equal to 0.1. Furthermore, for both codewords #0 and #1, the PDSCH BLER using the transport format indicated by the respective median CQI<sub>0</sub> + 1 and median CQI<sub>1</sub> + 1 shall be greater than or equal to 0.1.

Table 9.2.2.2-1: PUCCH 1-1 static test (TDD)

Parameter		Unit	Test 1		Test 2	
Bandwidth		MHz			10	
PDSCH transmission mode					4	
Uplink downlink configuration					2	
Special subframe configuration					4	
Downlink power allocation	$\rho_A$	dB			-3	
	$\rho_B$	dB			-3	
	$\sigma$	dB			0	
Propagation condition and antenna configuration			Clause B.1 (2 x 2)			
CodeBookSubsetRestriction bitmap			010000			
SNR (Note 2)		dB	10	11	16	17
$\hat{I}_{or}^{(j)}$		dB[mW/15kHz]	-88	-87	-82	-81
$N_{oc}^{(j)}$		dB[mW/15kHz]	-98		-98	
Max number of HARQ transmissions			1			
Physical channel for CQI/PMI reporting			PUSCH (Note 3)			
PUCCH Report Type			2			
Reporting periodicity		ms	$N_{pd} = 5$			
cqi-pmi-ConfigurationIndex			3			
ri-ConfigIndex			805 (Note 4)			
ACK/NACK feedback mode			Multiplexing			
<p>Note 1: Reference measurement channel RC.2 TDD according to Table A.4-1 with one sided dynamic OCNG Pattern OP.1 TDD as described in Annex A.5.2.1.</p> <p>Note 2: For each test, the minimum requirements shall be fulfilled for at least one of the two SNR(s) and the respective wanted signal input level.</p> <p>Note 3: To avoid collisions between CQI/PMI reports and HARQ-ACK it is necessary to report both on PUSCH instead of PUCCH. PDCCH DCI format 0 shall be transmitted in downlink SF#3 and #8 to allow periodic CQI/PMI to multiplex with the HARQ-ACK on PUSCH in uplink subframe SF#7 and #2.</p> <p>Note 4: RI reporting interval is set to the maximum allowable length of 160ms to minimise collisions between RI, CQI/PMI and HARQ-ACK reports. In the case when all three reports collide, it is expected that CQI/PMI reports will be dropped, while RI and HARQ-ACK will be multiplexed. At eNB, CQI report collection shall be skipped every 160ms during performance verification.</p>						

### 9.2.3 Minimum requirement PUCCH 1-1 (CSI Reference Symbols)

The minimum requirements for dual codeword transmission are defined in terms of a reporting spread of the wideband CQI value for codeword #1, and their BLER performance using the transport format indicated by the reported CQI median of codeword #0 and codeword #1. The precoding used at the transmitter is a fixed precoding matrix specified by the bitmap parameter *codebookSubsetRestriction*. The propagation condition assumed for the minimum performance requirement is defined in subclause B.1.

#### 9.2.3.1 FDD

The following requirements apply to UE Category  $\geq 2$ . For the parameters specified in table 9.2.3.1-1, and using the downlink physical channels specified in tables C.3.2-1 and C.3.2-2, the reported offset level of the wideband spatial differential CQI for codeword #1 (Table 7.2-2 in TS 36.213 [6]) shall be used to determine the wideband CQI index for codeword #1 as

$$\text{wideband CQI}_1 = \text{wideband CQI}_0 - \text{Codeword 1 offset level}$$

The wideband CQI<sub>1</sub> shall be within the set {median CQI<sub>1</sub> - 1, median CQI<sub>1</sub>, median CQI<sub>1</sub> + 1} for more than 90% of the time, where the resulting wideband values CQI<sub>1</sub> shall be used to determine the median CQI values for codeword #1. For both codewords #0 and #1, the PDSCH BLER using the transport format indicated by the respective median CQI<sub>0</sub> - 1

and median  $CQI_1 - 1$  shall be less than or equal to 0.1. Furthermore, for both codewords #0 and #1, the PDSCH BLER using the transport format indicated by the respective median  $CQI_0 + 1$  and median  $CQI_1 + 1$  shall be greater than or equal to 0.1.

**Table 9.2.3.1-1: PUCCH 1-1 static test (FDD)**

Parameter	Unit	Test 1		Test 2	
Bandwidth	MHz	10			
PDSCH transmission mode		9			
Downlink power allocation	$\rho_A$	dB		0	
	$\rho_B$	dB		0	
	$\rho_C$	dB		-3	
	$\sigma$	dB		-3	
Cell-specific reference signals		Antenna ports 0, 1			
CSI reference signals		Antenna ports 15, ..., 18			
CSI-RS periodicity and subframe offset $T_{CSI-RS} / \Delta_{CSI-RS}$		5/1			
CSI reference signal configuration		0			
Propagation condition and antenna configuration		Clause B.1 (4 x 2)			
Beamforming Model		As specified in Section B.4.3			
CodeBookSubsetRestriction bitmap		0x0000 0000 0100 0000			
SNR (Note 2)	dB	7	8	13	14
$\hat{I}_{or}^{(j)}$	dB[mW/15kHz]	-91	-90	-85	-84
$N_{oc}^{(j)}$	dB[mW/15kHz]	-98		-98	
Max number of HARQ transmissions		1			
Physical channel for CQI/PMI reporting		PUSCH (Note3)			
PUCCH Report Type for CQI/PMI		2			
Physical channel for RI reporting		PUCCH Format 2			
PUCCH Report Type for RI		3			
Reporting periodicity	ms	$N_{pd} = 5$			
CQI delay	ms	8			
<i>cqi-pmi-ConfigurationIndex</i>		2			
<i>ri-ConfigIndex</i>		1			
Note 1:	Reference measurement channel RC.7 FDD according to Table A.4-1 with one sided dynamic OCNG Pattern OP.1 FDD as described in Annex A.5.1.1.				
Note 2:	For each test, the minimum requirements shall be fulfilled for at least one of the two SNR(s) and the respective wanted signal input level.				
Note 3:	To avoid collisions between CQI/PMI reports and HARQ-ACK it is necessary to report both on PUSCH instead of PUCCH. PDCCCH DCI format 0 shall be transmitted in downlink SF#1 and #6 to allow periodic CQI/PMI to multiplex with the HARQ-ACK on PUSCH in uplink SF#0 and #5.				

### 9.2.3.1A FDD (With *channelMeasRestriction* configured)

The following requirements apply to UE Category  $\geq 2$ . For the parameters specified in table 9.2.3.1A-1, and using the downlink physical channels specified in tables C.3.2-1 and C.3.2-2, the reported offset level of the wideband spatial differential CQI for codeword #1 (Table 7.2-2 in TS 36.213 [6]) shall be used to determine the wideband CQI index for codeword #1 as

$$\text{wideband } CQI_1 = \text{wideband } CQI_0 - \text{Codeword 1 offset level}$$

The wideband  $CQI_1$  shall be within the set  $\{\text{median } CQI_1 - 1, \text{median } CQI_1, \text{median } CQI_1 + 1\}$  for more than 90% of the time, where the resulting wideband values  $CQI_1$  shall be used to determine the median CQI values for codeword #1. For both codewords #0 and #1, the PDSCH BLER using the transport format indicated by the respective median  $CQI_0 - 1$  and median  $CQI_1 - 1$  shall be less than or equal to 0.1. Furthermore, for both codewords #0 and #1, the PDSCH BLER using the transport format indicated by the respective median  $CQI_0 + 1$  and median  $CQI_1 + 1$  shall be greater than or equal to 0.1.



Table 9.2.3.1A-1: PUCCH 1-1 static test (FDD)

Parameter	Unit	Test 1		Test 2	
Bandwidth	MHz			10	
PDSCH transmission mode				9	
Downlink power allocation	$\rho_A$	dB		0	
	$\rho_B$	dB		0	
	$P_c$	dB		-3	
	$\sigma$	dB		-3	
Cell-specific reference signals		Antenna ports 0, 1			
e-MIMO Type		Class B			
Number of CSI-RS resource (K)		1			
<i>channelMeasRestriction</i>		Enable			
CSI reference signals		Antenna ports 15, ..., 18			
CSI-RS periodicity and subframe offset		5/1			
$T_{\text{CSI-RS}} / \Delta_{\text{CSI-RS}}$					
CSI reference signal configuration		0			
Propagation condition and antenna configuration		Clause B.1 (4 x 2)			
Beamforming Model		As specified in Section B.4.3			
CodeBookSubsetRestriction bitmap		0x0000 0000 0100 0000			
SNR (Note 2)	dB	[7]	[8]	[13]	[14]
$\hat{I}_{or}^{(j)}$	dB[mW/15kHz]	-91	-90	-85	-84
$N_{oc}^{(j)}$	dB[mW/15kHz]	-98		-98	
Max number of HARQ transmissions		1			
Physical channel for CQI/PMI reporting		PUSCH (Note3)			
PUCCH Report Type for CQI/PMI		2			
Physical channel for RI reporting		PUCCH Format 2			
PUCCH Report Type for RI		3			
Reporting periodicity	ms	$N_{pd} = 10$			
CQI delay	ms	8			
<i>cqi-pmi-ConfigurationIndex</i>		12			
<i>ri-ConfigIndex</i>		1			
PDSCH scheduled sub-frames		1,2,3,4,7,8,9			
NOTE 1: Reference measurement channel RC.7 FDD according to Table A.4-1 with one sided dynamic OCNG Pattern OP.1 FDD as described in Annex A.5.1.1.					
NOTE 2: For each test, the minimum requirements shall be fulfilled for at least one of the two SNR(s) and the respective wanted signal input level.					
NOTE 3: To avoid collisions between CQI/PMI reports and HARQ-ACK it is necessary to report both on PUSCH instead of PUCCH. PDCCH DCI format 0 shall be transmitted in downlink SF#1 to allow periodic CQI/PMI to multiplex with the HARQ-ACK on PUSCH in uplink #5.					
NOTE 4: In sub-frame 6, transmission power of CSI-RS REs is 9dB lower than CRS REs, in sub-frame 1, there is no power offset between CSI-RS REs and CRS REs.					

### 9.2.3.2 TDD

The following requirements apply to UE Category  $\geq 2$ . For the parameters specified in table 9.2.3.2-1, and using the downlink physical channels specified in tables C.3.2-1 and C.3.2-2, the reported offset level of the wideband spatial differential CQI for codeword #1 (Table 7.2-2 in TS 36.213 [6]) shall be used to determine the wideband CQI index for codeword #1 as

$$\text{wideband CQI}_1 = \text{wideband CQI}_0 - \text{Codeword 1 offset level}$$

The wideband CQI<sub>1</sub> shall be within the set {median CQI<sub>1</sub> - 1, median CQI<sub>1</sub>, median CQI<sub>1</sub> + 1} for more than 90% of the time, where the resulting wideband values CQI<sub>1</sub> shall be used to determine the median CQI values for codeword #1. For both codewords #0 and #1, the PDSCH BLER using the transport format indicated by the respective median CQI<sub>0</sub> - 1 and median CQI<sub>1</sub> - 1 shall be less than or equal to 0.1. Furthermore, for both codewords #0 and #1, the PDSCH BLER using the transport format indicated by the respective median CQI<sub>0</sub> + 1 and median CQI<sub>1</sub> + 1 shall be greater than or equal to 0.1.

Table 9.2.3.2-1: PUCCH 1-1 submode 1 static test (TDD)

Parameter	Unit	Test 1		Test 2	
Bandwidth	MHz			10	
PDSCH transmission mode				9	
Uplink downlink configuration				2	
Special subframe configuration				4	
Downlink power allocation	$\rho_A$	dB			0
	$\rho_B$	dB			0
	$\rho_C$	dB			-6
	$\sigma$	dB			-3
CRS reference signals		Antenna ports 0, 1			
CSI reference signals		Antenna ports 15, ..., 22			
CSI-RS periodicity and subframe offset $T_{\text{CSI-RS}} / \Delta_{\text{CSI-RS}}$		5 / 3			
CSI reference signal configuration		0			
Propagation condition and antenna configuration		Clause B.1 (8 x 2)			
Beamforming Model		As specified in Section B.4.3			
CodeBookSubsetRestriction bitmap		0x0000 0000 0020 0000 0000 0001 0000			
SNR (Note 2)	dB	4	5	10	11
$\hat{I}_{or}^{(j)}$	dB[mW/15kHz]	-94	-93	-88	-87
$N_{oc}^{(j)}$	dB[mW/15kHz]	-98		-98	
Max number of HARQ transmissions		1			
Physical channel for CQI/PMI reporting		PUSCH (Note 3)			
PUCCH Report Type for CQI/second PMI		2b			
Physical channel for RI reporting		PUSCH			
PUCCH Report Type for RI/ first PMI		5			
Reporting periodicity	ms	$M_{pd} = 5$			
CQI delay	ms	10 or 11			
<i>cqi-pmi-ConfigurationIndex</i>		3			
<i>ri-ConfigIndex</i>		805 (Note 4)			
ACK/NACK feedback mode		Multiplexing			
Note 1:	Reference measurement channel RC.7 TDD according to Table A.4-1 with one sided dynamic OCNG Pattern OP.1 TDD as described in Annex A.5.2.1.				
Note 2:	For each test, the minimum requirements shall be fulfilled for at least one of the two SNR(s) and the respective wanted signal input level.				
Note 3:	To avoid collisions between CQI/PMI reports and HARQ-ACK it is necessary to report both on PUSCH instead of PUCCH. PDCCCH DCI format 0 shall be transmitted in downlink SF#3 and #8 to allow periodic CQI/PMI to multiplex with the HARQ-ACK on PUSCH in uplink SF#7 and #2.				
Note 4:	RI reporting interval is set to the maximum allowable length of 160ms to minimise collisions between RI, CQI/PMI and HARQ-ACK reports. In the case when all three reports collide, it is expected that CQI/PMI reports will be dropped, while RI and HARQ-ACK will be multiplexed. At eNB, CQI report collection shall be skipped every 160ms during performance verification.				

### 9.2.3.2A TDD (With *channelMeasRestriction* configured)

The following requirements apply to UE Category  $\geq 2$ . For the parameters specified in table 9.2.3.2A-1, and using the downlink physical channels specified in tables C.3.2-1 and C.3.2-2, the reported offset level of the wideband spatial differential CQI for codeword #1 (Table 7.2-2 in TS 36.213 [6]) shall be used to determine the wideband CQI index for codeword #1 as

$$\text{wideband CQI}_1 = \text{wideband CQI}_0 - \text{Codeword 1 offset level}$$

The wideband CQI<sub>1</sub> shall be within the set {median CQI<sub>1</sub> -1, median CQI<sub>1</sub>, median CQI<sub>1</sub> +1} for more than 90% of the time, where the resulting wideband values CQI<sub>1</sub> shall be used to determine the median CQI values for codeword #1. For both codewords #0 and #1, the PDSCH BLER using the transport format indicated by the respective median CQI<sub>0</sub> - 1 and median CQI<sub>1</sub> - 1 shall be less than or equal to 0.1. Furthermore, for both codewords #0 and #1, the PDSCH BLER

using the transport format indicated by the respective median  $CQI_0 + 1$  and median  $CQI_1 + 1$  shall be greater than or equal to 0.1.

**Table 9.2.3.2A-1: PUCCH 1-1 submode 1 static test (TDD)**

Parameter		Unit	Test 1		Test 2	
Bandwidth		MHz			10	
PDSCH transmission mode					9	
Uplink downlink configuration					2	
Special subframe configuration					4	
Downlink power allocation	$\rho_A$	dB			0	
	$\rho_B$	dB			0	
	$P_C$	dB			-6	
	$\sigma$	dB			-3	
CRS reference signals					Antenna ports 0, 1	
e-MIMO Type					Class B	
Number of CSI-RS resource (K)					1	
<i>channelMeasRestriction</i>					Enable	
CSI reference signals					Antenna ports 15, ..., 22	
CSI-RS periodicity and subframe offset $T_{CSI-RS} / \Delta_{CSI-RS}$					5/3	
CSI reference signal configuration					0	
Propagation condition and antenna configuration					Clause B.1 (8 x 2)	
Beamforming Model					As specified in Section B.4.3	
CodeBookSubsetRestriction bitmap					0x0000 0000 0020 0000 0000 0001 0000	
SNR (Note 2)		dB	[4]	[5]	[10]	[11]
$\hat{I}_{or}^{(j)}$		dB[mW/15kHz]	-94	-93	-88	-87
$N_{oc}^{(j)}$		dB[mW/15kHz]	-98		-98	
Max number of HARQ transmissions					1	
Physical channel for CQI/PMI reporting					PUSCH (Note 3)	
PUCCH Report Type for CQI/second PMI					2b	
Physical channel for RI reporting					PUSCH	
PUCCH Report Type for RI/ first PMI					5	
Reporting periodicity		ms			$N_{pd} = 10$	
CQI delay		ms			10 or 11	
<i>cqi-pmi-ConfigurationIndex</i>					13	
<i>ri-ConfigIndex</i>					805 (Note 4)	
ACK/NACK feedback mode					Multiplexing	
PDSCH scheduled sub-frames					3, 4, 9	
NOTE 1: Reference measurement channel RC.7 TDD according to Table A.4-1 with one sided dynamic OCNG Pattern OP.1 TDD as described in Annex A.5.2.1.						
NOTE 2: For each test, the minimum requirements shall be fulfilled for at least one of the two SNR(s) and the respective wanted signal input level.						
NOTE 3: To avoid collisions between CQI/PMI reports and HARQ-ACK it is necessary to report both on PUSCH instead of PUCCH. PDCCCH DCI format 0 shall be transmitted in downlink SF#3 to allow periodic CQI/PMI to multiplex with the HARQ-ACK on PUSCH in uplink SF#7.						
NOTE 4: RI reporting interval is set to the maximum allowable length of 160ms to minimise collisions between RI, CQI/PMI and HARQ-ACK reports. In the case when all three reports collide, it is expected that CQI/PMI reports will be dropped, while RI and HARQ-ACK will be multiplexed. At eNB, CQI report collection shall be skipped every 160ms during performance verification.						
NOTE 5: In sub-frame 8, transmission power of CSI-RS REs is 9dB lower than CRS REs, in sub-frame 3, there is no power offset between CSI-RS REs and CRS REs.						

## 9.2.4 Minimum requirement PUCCH 1-1 (With Single CSI Process)

The minimum requirements for dual codeword transmission are defined in terms of a reporting spread of the wideband CQI value for codeword #1, and their BLER performance using the transport format indicated by the reported CQI

median of codeword #0 and codeword #1. The precoding used at the transmitter is a fixed precoding matrix specified by the bitmap parameter *codebookSubsetRestriction*. The propagation condition assumed for the minimum performance requirement is defined in subclause B.1.

If UE supporting *interferenceMeasRestriction*, test cases specified in 9.2.4.1A and 9.2.4.2A are applicable for such UE otherwise test cases specified in 9.2.4.1 and 9.2.4.2 are applied.

#### 9.2.4.1 FDD

The following requirements apply to UE Category  $\geq 2$ . For the parameters specified in table 9.2.4.1-1, and using the downlink physical channels specified in Tables C.3.4-1 and C.3.4-2, the reported offset level of the wideband spatial differential CQI for codeword #1 (Table 7.2-2 in TS 36.213 [6]) shall be used to determine the wideband CQI index for codeword #1 as

$$\text{wideband CQI}_1 = \text{wideband CQI}_0 - \text{Codeword 1 offset level}$$

The wideband CQI<sub>1</sub> shall be within the set {median CQI<sub>1</sub> - 1, median CQI<sub>1</sub>, median CQI<sub>1</sub> + 1} for more than 90% of the time, where the resulting wideband values CQI<sub>1</sub> shall be used to determine the median CQI values for codeword #1. For both codewords #0 and #1, the PDSCH BLER using the transport format indicated by the respective median CQI<sub>0</sub> - 1 and median CQI<sub>1</sub> - 1 shall be less than or equal to 0.1. Furthermore, for both codewords #0 and #1, the PDSCH BLER using the transport format indicated by the respective median CQI<sub>0</sub> + 1 and median CQI<sub>1</sub> + 1 shall be greater than or equal to 0.1.

Table 9.2.4.1-1: PUCCH 1-1 static test (FDD)

Parameter	Unit	Test 1		Test 2		
		TP1	TP2	TP1	TP2	
Bandwidth	MHz	10				
PDSCH transmission mode		10				
Downlink power allocation (Note 1)	$\rho_A$	dB	0	0	0	0
	$\rho_B$	dB	0	0	0	0
	$\rho_C$	dB	-3	-3	-3	-3
	$\sigma$	dB	-3	N/A	-3	N/A
Cell ID		0		0		
Cell-specific reference signals		Antenna ports 0, 1	(Note 2)	Antenna ports 0, 1	(Note 2)	
CSI reference signals		Antenna ports 15, ..., 18	N/A	Antenna ports 15, ..., 18	N/A	
CSI-RS periodicity and subframe offset $T_{CSI-RS} / \Delta_{CSI-RS}$		5/1	N/A	5/1	N/A	
CSI-RS configuration		0	N/A	0	N/A	
Zero-Power CSI-RS configuration $i_{CSI-RS} / ZeroPowerCSI-RS$ bitmap		1 / 001000000000 0000	1 / 100000000000 00000	1 / 001000000000 0000	1 / 100000000000 00000	
CSI-IM configuration $i_{CSI-RS} / ZeroPowerCSI-RS$ bitmap		1 / 001000000000 0000	N/A	1 / 001000000000 0000	N/A	
CSI process configuration Signal/Interference/Reporting mode		CSI-RS/CSI-IM/PUCCH 1-1		CSI-RS/CSI-IM/PUCCH 1-1		
Propagation condition and antenna configuration		Clause B.1 (4 x 2)	Clause B.1 (2 x 2)	Clause B.1 (4 x 2)	Clause B.1 (2 x 2)	
CodeBookSubsetRestriction bitmap		0x0000 0000 0100 0000	100000	0x0000 0000 0100 0000	100000	
SNR (Note 3)	dB	20	6   7	20	14   15	
$\hat{I}_{or}^{(j)}$	dB[mW/15kHz]	-78	-92   -91	-78	-84   -83	
$N_{oc}^{(j)}$	dB[mW/15kHz]	-98		-98		
Modulation / Information bit payload		(Note4)	QPSK / 4392	(Note4)	QPSK / 4392	
Max number of HARQ transmissions		1	N/A	1	N/A	
Physical channel for CQI/PMI reporting		PUSCH (Note5)	N/A	PUSCH (Note5)	N/A	
PUCCH Report Type for CQI/PMI		2	N/A	2	N/A	
PUCCH Report Type for RI		3	N/A	3	N/A	
Reporting periodicity	ms	$N_{pd} = 5$	N/A	$N_{pd} = 5$	N/A	
CQI Delay	ms	8	N/A	8	N/A	
$cqi-pmi-ConfigurationIndex$		2	N/A	2	N/A	
$ri-ConfigIndex$		1	N/A	1	N/A	
PDSCH scheduled sub-frames		1,2,3,4,6,7,8,9		1,2,3,4,6,7,8,9		
Timing offset between TPs	us	0		0		
Frequency offset between TPs	Hz	0		0		
Note1:	Reference measurement channel RC.10 FDD according to Table A.4-1 with one sided dynamic OCN Pattern OP.1 FDD as described in Annex A.5.1.1.					
Note 2:	REs for antenna ports 0 and 1 CRS have zero transmission power.					
Note 3:	For each test, the minimum requirements shall be fulfilled for at least one of the two SNR(s) and the respective wanted signal input level.					
Note 4:	N/A.					
Note 5:	To avoid collisions between CQI/PMI reports and HARQ-ACK it is necessary to report both on PUSCH instead of PUCCH. PDCCH DCI format 0 shall be transmitted in downlink SF#1 and #6 to allow periodic CQI/PMI to multiplex with the HARQ-ACK on PUSCH in uplink SF#0 and #5.					

#### 9.2.4.1A FDD (With *interferenceMeasRestriction* configured)

The following requirements apply to UE Category  $\geq 2$ . For the parameters specified in table 9.2.4.1A-1, and using the downlink physical channels specified in Tables C.3.4-1 and C.3.4-2, the reported offset level of the wideband spatial differential CQI for codeword #1 (Table 7.2-2 in TS 36.213 [6]) shall be used to determine the wideband CQI index for codeword #1 as

$$\text{wideband CQI}_1 = \text{wideband CQI}_0 - \text{Codeword 1 offset level}$$

The wideband  $\text{CQI}_1$  shall be within the set  $\{\text{median CQI}_1 - 1, \text{median CQI}_1, \text{median CQI}_1 + 1\}$  for more than 90% of the time, where the resulting wideband values  $\text{CQI}_1$  shall be used to determine the median CQI values for codeword #1. For both codewords #0 and #1, the PDSCH BLER using the transport format indicated by the respective median  $\text{CQI}_0 - 1$  and median  $\text{CQI}_1 - 1$  shall be less than or equal to 0.1. Furthermore, for both codewords #0 and #1, the PDSCH BLER using the transport format indicated by the respective median  $\text{CQI}_0 + 1$  and median  $\text{CQI}_1 + 1$  shall be greater than or equal to 0.1.

**Table 9.2.4.1A-1: PUCCH 1-1 static test (FDD)**

Parameter		Unit	Test 1			Test 2		
			TP1	TP2		TP1	TP2	
Bandwidth		MHz	10					
PDSCH transmission mode			10					
Downlink power allocation (Note 1)	$\rho_A$	dB	0	0		0	0	
	$\rho_B$	dB	0	0		0	0	
	$P_c$	dB	-3	-3		-3	-3	
	$\sigma$	dB	-3	N/A		-3	N/A	
Cell ID			0			0		
Cell-specific reference signals			Antenna ports 0, 1	(Note 2)		Antenna ports 0, 1	(Note 2)	
e-MIMO Type			Class B					
Number of CSI-RS resource (K)			1					
interferenceMeasRestriction			Enable					
CSI reference signals			Antenna ports 15, ..., 18	N/A		Antenna ports 15, ..., 18	N/A	
CSI-RS periodicity and subframe offset $T_{CSI-RS} / \Delta_{CSI-RS}$			5/1	N/A		5/1	N/A	
CSI-RS configuration			0	N/A		0	N/A	
Zero-Power CSI-RS configuration $I_{CSI-RS} / ZeroPowerCSI-RS$ bitmap			1 / 001000000000 0000	1 / 100000000000 00000		1 / 001000000000 0000	1 / 100000000000 00000	
CSI-IM configuration $I_{CSI-RS} / ZeroPowerCSI-RS$ bitmap			1 / 001000000000 0000	N/A		1 / 001000000000 0000	N/A	
CSI process configuration Signal/Interference/Reporting mode			CSI-RS/CSI-IM/PUCCH 1-1			CSI-RS/CSI-IM/PUCCH 1-1		
Propagation condition and antenna configuration			Clause B.1 (4 x 2)	Clause B.1 (2 x 2)		Clause B.1 (4 x 2)	Clause B.1 (2 x 2)	
CodeBookSubsetRestriction bitmap			0x0000 0000 0100 0000	100000		0x0000 0000 0100 0000	100000	
SNR (Note 3)	Sub-frame 6	dB	20	[15]	[16]	20	[23]	[24]
	Other sub-frames		20	6	7	20	14	15
$\hat{I}_{or}^{(j)}$	Sub-frame 6	dB[mW/15kHz]	-78	[-83]	[-82]	-78	[-75]	[-74]
	Other sub-frames		-78	-92	-91	-78	-84	-83
$N_{oc}^{(j)}$		dB[mW/15kHz]	-98			-98		
Modulation / Information bit payload			(Note4)	QPSK / 4392		(Note4)	QPSK / 4392	
Max number of HARQ transmissions			1	N/A		1	N/A	
Physical channel for CQI/PMI reporting			PUSCH (Note5)	N/A		PUSCH (Note5)	N/A	
PUCCH Report Type for CQI/PMI			2	N/A		2	N/A	
PUCCH Report Type for RI			3	N/A		3	N/A	
Reporting periodicity		ms	$N_{pd} = 10$	N/A		$N_{pd} = 10$	N/A	
CQI Delay		ms	8	N/A		8	N/A	
cqi-pmi-ConfigurationIndex			12	N/A		12	N/A	
ri-ConfigIndex			1	N/A		1	N/A	
PDSCH scheduled sub-frames			1,2,3,4,7,8,9	1,2,3,4,6,7,8,9		1,2,3,4,7,8,9	1,2,3,4,6,7,8,9	
Timing offset between TPs		us	0			0		
Frequency offset between TPs		Hz	0			0		



NOTE 1: Reference measurement channel RC.10 FDD according to Table A.4-1 with one sided dynamic OCNG Pattern OP.1 FDD as described in Annex A.5.1.1.

NOTE 2: REs for antenna ports 0 and 1 CRS have zero transmission power.

NOTE 3: For each test, the minimum requirements shall be fulfilled for at least one of the two SNR(s) and the respective wanted signal input level.

NOTE 4: N/A.

NOTE 5: To avoid collisions between CQI/PMI reports and HARQ-ACK it is necessary to report both on PUSCH instead of PUCCH. PDCCH DCI format 0 shall be transmitted in downlink SF#1 to allow periodic CQI/PMI to multiplex with the HARQ-ACK on PUSCH in uplink #5.

#### 9.2.4.2 TDD

The following requirements apply to UE Category  $\geq 2$ . For the parameters specified in table 9.2.4.2-1, and using the downlink physical channels specified in Tables C.3.4-1 and C.3.4-2, the reported offset level of the wideband spatial differential CQI for codeword #1 (Table 7.2-2 in TS 36.213 [6]) shall be used to determine the wideband CQI index for codeword #1 as

$$\text{wideband CQI}_1 = \text{wideband CQI}_0 - \text{Codeword 1 offset level}$$

The wideband CQI<sub>1</sub> shall be within the set {median CQI<sub>1</sub> - 1, median CQI<sub>1</sub>, median CQI<sub>1</sub> + 1} for more than 90% of the time, where the resulting wideband values CQI<sub>1</sub> shall be used to determine the median CQI values for codeword #1. For both codewords #0 and #1, the PDSCH BLER using the transport format indicated by the respective median CQI<sub>0</sub> - 1 and median CQI<sub>1</sub> - 1 shall be less than or equal to 0.1. Furthermore, for both codewords #0 and #1, the PDSCH BLER using the transport format indicated by the respective median CQI<sub>0</sub> + 1 and median CQI<sub>1</sub> + 1 shall be greater than or equal to 0.1.

**Table 9.2.4.2-1: PUCCH 1-1 static test (TDD)**

Parameter	Unit	Test 1			Test 2		
		TP1	TP2		TP1	TP2	
Bandwidth	MHz	10					
PDSCH transmission mode		10					
Uplink downlink configuration		2					
Special subframe configuration		4					
Downlink power allocation (Note 1)	$\rho_A$	dB	0	0	0	0	
	$\rho_B$	dB	0	0	0	0	
	$\rho_C$	dB	-6	-6	-6	-6	
	$\sigma$	dB	-3	N/A	-3	N/A	
Cell ID		0			0		
Cell-specific reference signals		Antenna ports 0, 1	(Note 2)		Antenna ports 0, 1	(Note 2)	
CSI reference signals		Antenna ports 15, ..., 22	N/A		Antenna ports 15, ..., 22	N/A	
CSI-RS periodicity and subframe offset $T_{CSI-RS} / \Delta_{CSI-RS}$		5/3	N/A		5/3	N/A	
CSI-RS configuration		0	N/A		0	N/A	
Zero-Power CSI-RS configuration $I_{CSI-RS} / ZeroPowerCSI-RS$ bitmap		3 / 001000000000 0000	3 / 100001000000 00000		3 / 001000000000 0000	3 / 100001000000 00000	
CSI-IM configuration $I_{CSI-RS} / ZeroPowerCSI-RS$ bitmap		3 / 001000000000 0000	N/A		3 / 001000000000 0000	N/A	
CSI process configuration Signal/Interference/Reporting mode		CSI-RS/CSI-IM/PUCCH 1-1			CSI-RS/CSI-IM/PUCCH 1-1		
Propagation condition and antenna configuration		Clause B.1 (8 x 2)	Clause B.1 (2 x 2)		Clause B.1 (8 x 2)	Clause B.1 (2 x 2)	
CodeBookSubsetRestriction bitmap		0x0000 0000 0020 0000 0000 0001 0000	100000		0x0000 0000 0020 0000 0000 0001 0000	100000	
SNR (Note 3)	dB	17	6	7	17	14	15
$\hat{I}_{or}^{(j)}$	dB[mW/15kHz]	-81	-92	-91	-81	-84	-83
$N_{oc}^{(j)}$	dB[mW/15kHz]	-98			-98		
Modulation / Information bit payload		(Note4)	QPSK / 4392		(Note4)	QPSK / 4392	
Max number of HARQ transmissions		1	N/A		1	N/A	
Physical channel for CQI/PMI reporting		PUSCH (Note5)	N/A		PUSCH (Note5)	N/A	
PUCCH Report Type for CQI/second PMI		2b	N/A		2b	N/A	
Physical channel for RI reporting		PUSCH	N/A		PUSCH	N/A	
PUCCH Report Type for RI/ first PMI		5	N/A		5	N/A	
Reporting periodicity	ms	$N_{pd} = 5$	N/A		$N_{pd} = 5$	N/A	
CQI Delay	ms	10 or 11	N/A		10 or 11	N/A	
$cqi-pmi-ConfigurationIndex$		3	N/A		3	N/A	
$ri-ConfigIndex$		805 (Note 6)	N/A		805 (Note 6)	N/A	
ACK/NACK feedback mode		Multiplexing	N/A		Multiplexing	N/A	
PDSCH scheduled sub-frames		3,4,8,9			3,4,8,9		
Timing offset between TPs	us	0			0		
Frequency offset between TPs	Hz	0			0		

Note 1:	Reference measurement channel RC.10 TDD according to Table A.4-1 with one sided dynamic OCNG Pattern OP.1 TDD as described in Annex A.5.2.1.
Note 2:	REs for antenna ports 0 and 1 CRS have zero transmission power.
Note 3:	For each test, the minimum requirements shall be fulfilled for at least one of the two SNR(s) and the respective wanted signal input level.
Note 4:	N/A.
Note 5:	To avoid collisions between CQI/PMI reports and HARQ-ACK it is necessary to report both on PUSCH instead of PUCCH. PDCCH DCI format 0 shall be transmitted in downlink SF#3 and #8 to allow periodic CQI/PMI to multiplex with the HARQ-ACK on PUSCH in uplink SF#7 and #2.
Note 6:	RI reporting interval is set to the maximum allowable length of 160ms to minimise collisions between RI, CQI/PMI and HARQ-ACK reports. In the case when all three reports collide, it is expected that CQI/PMI reports will be dropped, while RI and HARQ-ACK will be multiplexed. At eNB, CQI report collection shall be skipped every 160ms during performance verification.

#### 9.2.4.2A TDD (With *interferenceMeasRestriction* configured)

The following requirements apply to UE Category  $\geq 2$ . For the parameters specified in table 9.2.4.2A-1, and using the downlink physical channels specified in Tables C.3.4-1 and C.3.4-2, the reported offset level of the wideband spatial differential CQI for codeword #1 (Table 7.2-2 in TS 36.213 [6]) shall be used to determine the wideband CQI index for codeword #1 as

$$\text{wideband CQI}_1 = \text{wideband CQI}_0 - \text{Codeword 1 offset level}$$

The wideband CQI<sub>1</sub> shall be within the set {median CQI<sub>1</sub> - 1, median CQI<sub>1</sub>, median CQI<sub>1</sub> + 1} for more than 90% of the time, where the resulting wideband values CQI<sub>1</sub> shall be used to determine the median CQI values for codeword #1. For both codewords #0 and #1, the PDSCH BLER using the transport format indicated by the respective median CQI<sub>0</sub> - 1 and median CQI<sub>1</sub> - 1 shall be less than or equal to 0.1. Furthermore, for both codewords #0 and #1, the PDSCH BLER using the transport format indicated by the respective median CQI<sub>0</sub> + 1 and median CQI<sub>1</sub> + 1 shall be greater than or equal to 0.1.

**Table 9.2.4.2A-1: PUCCH 1-1 static test (TDD)**

Parameter		Unit	Test 1				Test 2			
			TP1		TP2		TP1		TP2	
Bandwidth		MHz	10							
PDSCH transmission mode			10							
Uplink downlink configuration			2							
Special subframe configuration			4							
Downlink power allocation (Note 1)	$\rho_A$	dB	0	0	0	0	0	0		
	$\rho_B$	dB	0	0	0	0	0			
	$\rho_C$	dB	-6	-6	-6	-6	-6			
	$\sigma$	dB	-3	N/A	-3	N/A	-3	N/A		
Cell ID			0				0			
Cell-specific reference signals			Antenna ports 0, 1		(Note 2)	Antenna ports 0, 1		(Note 2)		
e-MIMO Type			Class B							
Number of CSI-RS resource (K)			1							
<i>interferenceMeasRestriction</i>			Enable							
CSI reference signals			Antenna ports 15,...,22		N/A	Antenna ports 15,...,22		N/A		
CSI-RS periodicity and subframe offset $T_{CSI-RS} / \Delta_{CSI-RS}$			5/3		N/A	5/3		N/A		
CSI-RS configuration			0		N/A	0		N/A		
Zero-Power CSI-RS configuration $i_{CSI-RS} / ZeroPowerCSI-RS$ bitmap			3 / 0010000000000000		3 / 1000010000000000	3 / 0010000000000000		3 / 1000010000000000		
CSI-IM configuration $i_{CSI-RS} / ZeroPowerCSI-RS$ bitmap			3 / 0010000000000000		N/A	3 / 0010000000000000		N/A		
CSI process configuration Signal/Interference/Reporting mode			CSI-RS/CSI-IM/PUCCH 1-1				CSI-RS/CSI-IM/PUCCH 1-1			
Propagation condition and antenna configuration			Clause B.1 (8 x 2)		Clause B.1 (2 x 2)	Clause B.1 (8 x 2)		Clause B.1 (2 x 2)		
CodeBookSubsetRestriction bitmap			0x0000 0000 0020 0000 0000 0001 0000		100000	0x0000 0000 0020 0000 0000 0001 0000		100000		
SNR (Note 3)	Sub-frame 8	dB	17	[15]	[16]	17	[23]	[24]		
	Other sub-frames		17	6	7	17	14	15		
$\hat{I}_{or}^{(j)}$	Sub-frame 8	dB[mW/15kHz]	-81	[-83]	[-82]	-81	[-75]	[-74]		
	Other sub-frames		-81	-92	-91	-81	-84	-83		
$N_{oc}^{(j)}$		dB[mW/15kHz]	-98				-98			
Modulation / Information bit payload			(Note4)	QPSK / 4392		(Note4)	QPSK / 4392			
Max number of HARQ transmissions			1		N/A	1		N/A		
Physical channel for CQI/PMI reporting			PUSCH (Note5)		N/A	PUSCH (Note5)		N/A		
PUCCH Report Type for CQI/second PMI			2b		N/A	2b		N/A		
Physical channel for RI reporting			PUSCH		N/A	PUSCH		N/A		
PUCCH Report Type for RI/ first PMI			5		N/A	5		N/A		
Reporting periodicity		ms	$N_{pd} = 10$		N/A	$N_{pd} = 10$		N/A		
CQI Delay		ms	10 or 11		N/A	10 or 11		N/A		
<i>cqi-pmi-ConfigurationIndex</i>			13		N/A	13		N/A		
<i>ri-ConfigIndex</i>			805 (Note 6)		N/A	805 (Note 6)		N/A		
ACK/NACK feedback mode			Multiplexing		N/A	Multiplexing		N/A		
PDSCH scheduled sub-frames			3,4,9		3,4,8,9	3,4,9		3,4,8,9		
Timing offset between TPs		us	0				0			
Frequency offset between TPs		Hz	0				0			

NOTE 1: Reference measurement channel RC.10 TDD according to Table A.4-1 with one sided dynamic OCNG Pattern OP.1 TDD as described in Annex A.5.2.1.

NOTE 2: REs for antenna ports 0 and 1 CRS have zero transmission power.

NOTE 3: For each test, the minimum requirements shall be fulfilled for at least one of the two SNR(s) and the respective wanted signal input level.

NOTE 4: N/A.

NOTE 5: To avoid collisions between CQI/PMI reports and HARQ-ACK it is necessary to report both on PUSCH instead of PUCCH. PDCCH DCI format 0 shall be transmitted in downlink SF#3 to allow periodic CQI/PMI to multiplex with the HARQ-ACK on PUSCH in uplink SF#7.

NOTE 6: RI reporting interval is set to the maximum allowable length of 160ms to minimise collisions between RI, CQI/PMI and HARQ-ACK reports. In the case when all three reports collide, it is expected that CQI/PMI reports will be dropped, while RI and HARQ-ACK will be multiplexed. At eNB, CQI report collection shall be skipped every 160ms during performance verification.

### 9.2.5 Minimum requirement PUCCH 1-1 (when *csi-SubframeSet-r12* and *EIMTA-MainConfigServCell-r12* are configured)

The following requirements apply to UE Category  $\geq 2$  which supports eIMTA TDD UL-DL reconfiguration for TDD serving cell(s) via monitoring PDCCH with eIMTA-RNTI and Rel-12 CSI subframe sets. For the parameters specified in table 9.2.5-1, and using the downlink physical channels specified in Tables C.3.2-1 and C.3.2-2, for each CSI subframe set, the reported CQI value shall be in the range of  $\pm 1$  of the reported median more than 90% of the time. For each CSI subframe set, if the PDSCH BLER using the transport format indicated by median CQI is less than or equal to 0.1, the BLER using the transport format indicated by the (median CQI + 1) shall be greater than 0.1. If the PDSCH BLER using the transport format indicated by the median CQI is greater than 0.1, the BLER using transport format indicated by (median CQI - 1) shall be less than or equal to 0.1. The difference of the median CQI obtained by reports in CSI subframe sets  $C_{CSI,0}$  and the median CQI obtained by reports in CSI subframe sets  $C_{CSI,1}$  shall be larger than or equal to 3.

**Table 9.2.5-1: PUCCH 1-1 static test (TDD)**



Parameter	Unit	Test	
Bandwidth	MHz	10	
PDSCH transmission mode		9	
Uplink downlink configuration in SIB1		0	
Downlink HARQ reference configuration (eimta-HarqReferenceConfig-r12) (Note 4)		2	
Set of dynamic TDD UL-DL configurations (Notes 4,5)		{0, 2}	
Periodicity of monitoring the L1 reconfiguration DCI (eimta-CommandPeriodicity-r12)	ms	10	
Set of subframes to monitor the L1 reconfiguration DCI (eimta-CommandSubframeSet-r12)		SF#5	
CSI-MeasSubframeSet-r12		0001100011	
Special subframe configuration		4	
Downlink power allocation	$\rho_A$	dB	0
	$\rho_B$	dB	0
	$\rho_C$	dB	0
	$\sigma$	dB	-3
CRS reference signals		Antenna ports 0, 1	
CSI reference signals		Antenna ports 15,16	
CSI-RS periodicity and subframe offset $T_{CSI-RS} / \Delta_{CSI-RS}$		5/4	
CSI reference signal configuration		4	
Zero-Power CSI-RS configuration 0 $l_{CSI-RS} / ZeroPowerCSI-RS$ bitmap		0 / 0000010000000000	
Zero-Power CSI-RS configuration 1 $l_{CSI-RS} / ZeroPowerCSI-RS$ bitmap		4 / 0100000000000000	
Propagation condition and antenna configuration		Clause B.1 (2 x 2)	
Beamforming Model		As specified in Section B.4.3	
CodeBookSubsetRestriction bitmap		'000001'	
SNR in CSI subframe set 0	dB	0	1
SNR in CSI subframe set 1	dB	10	11
$\hat{I}_{or}^{(j)}$	dB[mW/15kHz]	-98	-97
$N_{oc1}^{(j)}$ for CSI subframe set 0	dB[mW/15kHz]	-98	-98
$N_{oc2}^{(j)}$ for CSI subframe set 1	dB[mW/15kHz]	-108	-108
PDSCH scheduled subframes for CSI subframe set 0		0,5	
PDSCH scheduled subframes for CSI subframe set 1		3,4,8,9	
Max number of HARQ transmissions		1	
Physical channel for CQI/PMI reporting		PUSCH (Note 6)	
PUCCH Report Type for CQI/second PMI		2b	
Physical channel for RI reporting		PUSCH	
PUCCH Report Type for RI/ first PMI		5	
Reporting periodicity	ms	$N_{pd} = 10$ for each Rel-12 CSI subframe set	
CQI delay	ms	14 for CSI subframe set 0 12 for CSI subframe set 1	
<i>cqi-pmi-ConfigurationIndex</i>		8 for set 0 13 for set 1	
<i>ri-ConfigIndex</i>		805 for both set 0 and set 1 (Note 7)	
ACK/NACK feedback mode		Multiplexing	

Note 1:	Reference measurement channel RC.19 TDD according to Table A.4-1 with one sided dynamic OCNG Pattern OP.1 TDD and dynamic OCNG Pattern with multiple non-contiguous blocks OP.7 TDD as described in Annex A.5.2.1/7 for CSI subframe set 0.
Note 2:	Reference measurement channel RC.20 TDD according to Table A.4-1 with one sided dynamic OCNG Pattern OP.1 TDD as described in Annex A.5.2.1 for CSI subframe set 1.
Note 3:	In the test, the minimum requirements shall be fulfilled for at least one of the two SNR(s) and the respective wanted signal input level for each CSI subframe set separately.
Note 4:	As specified in Table 4.2-2 in TS 36.211.
Note 5:	UL/DL configuration in PDCCH with eIMTA-RNTI is cyclically selected from the given set on a per-DCI basis.
Note 6:	To avoid collisions between CQI/PMI reports and HARQ-ACK it is necessary to report both on PUSCH instead of PUCCH. PDCCH DCI format 0 shall be transmitted in downlink SF#1 and #6 to allow periodic CQI/PMI to multiplex with the HARQ-ACK on PUSCH in uplink SF#7 and #2. CQI/PMI reports for CSI subframe set 0 is transmitted in SF#2 and CQI/PMI reports for CSI subframe set 1 is transmitted in SF#7.
Note 7:	RI reporting interval is set to the maximum allowable length of 160ms to minimise collisions between RI, CQI/PMI and HARQ-ACK reports. In the case when all three reports collide, it is expected that CQI/PMI reports will be dropped, while RI and HARQ-ACK will be multiplexed. At eNB, CQI report collection shall be skipped every 160ms during performance verification.

## 9.2.6 Minimum requirement PUSCH 3-0 (Cell-Specific Reference Symbols)

### 9.2.6.1 Frame structure type 3 with FDD Pcell

The following requirements apply to UE Category  $\geq 1$ . For the parameters specified in Table 9.2.6.1-1, Table 9.2.6.1-2, and using the downlink physical channels specified in tables C.3.2-1 and C.3.2-2, two sets of CQI reports are obtained for LAA Scell. The first one is obtained by reports whose reference resource is in the downlink subframes with 6 dB transmission power boost, i.e., high power subframes. The second one is obtained by reports whose reference resource is in the downlink subframe with 0 dB transmission power boost, i.e., low power subframe. In the test, PDSCH transport format in high power subframe is determined by first set of CQI reports and PDSCH transport format in low power subframe is determined by second set of CQI reports.

The reported CQI value in the first set of reports shall be in the range of  $\pm 1$  of the reported median more than 90% of the first set of reports. The reported CQI value in the second set of reports shall be in the range of  $\pm 1$  of the reported median more than 90% of the second set of reports.

If the PDSCH BLER in the high power subframes using the transport format indicated by wideband CQI median is less than or equal to 0.1, the BLER in high power subframes using the transport format indicated by the (wideband CQI median + 1) shall be greater than 0.1. If the PDSCH BLER in the high power subframes using the transport format indicated by the wideband CQI median is greater than 0.1, the BLER in high power subframes using transport format indicated by (wideband CQI median - 1) shall be less than or equal to 0.1.

If the PDSCH BLER in the low power subframes using the transport format indicated by wideband CQI median is less than or equal to 0.1, the BLER in low power subframes using the transport format indicated by the (wideband CQI median + 1) shall be greater than 0.1. If the PDSCH BLER in the low power subframes using the transport format indicated by the wideband CQI median is greater than 0.1, the BLER in low power subframes using transport format indicated by (wideband CQI median - 1) shall be less than or equal to 0.1.

The value of the wideband CQI median for first set of CQI reports minus the wideband CQI median for second set of CQI reports shall be larger than or equal to 2 in Test 1 and Test 2.

Table 9.2.6.1-1: Parameters for PUSCH 3-0 static test on FDD Pcell

Parameter	Unit	Value	
Bandwidth	MHz	20	
PDSCH transmission mode		3	
Downlink power allocation	$\rho_A$	dB	-3
	$\rho_B$	dB	-3
	$\sigma$	dB	0
Propagation condition and antenna configuration		Clause B.1 (2 x 2)	
SNR	dB	20	
$\hat{I}_{or}^{(j)}$	dB[mW/15kHz]	-78	
$N_{oc}^{(j)}$	dB[mW/15kHz]	-98	
Max number of HARQ transmissions		1	
Reporting mode		PUSCH 3-0	
CSI request field		'10'	
trigger1 (Note 2)		01000000	
trigger2 (Note 2)		00000000	
Note 1:	PCell is used for HARQ ACK/NACK feedback and aperiodic CSI triggering/reporting. One sided dynamic OCNG Pattern OP.1 FDD as described in A.5.1.1 is transmitted on PCell on all RBs, but PDSCH for user data is not transmitted on PCell.		
Note 2:	trigger1 and trigger2 are defined as TS 36.331 for aperiodicCSI-Trigger. They Indicate for which serving cell(s) the aperiodic CSI report is triggered when one or more SCells are configured. PDCCH DCI format 0 with a trigger for aperiodic CQI is transmitted periodically in subframe 1 and subframe 6 with 5ms periodicity.		

Table 9.2.6.1-2: PUSCH 3-0 static test on LAA Scell

Parameter		Unit	Test 1	Test 2
Bandwidth		MHz	20	
PDSCH transmission mode			3	
Downlink power allocation	$\rho_A$	dB	-3	
	$\rho_B$	dB	-3	
	$\sigma$	dB	0	
Propagation condition and antenna configuration			Clause B.1 (2x2)	
SNR in subframes with 6 dB power boost (Note 2)		dB	9	10
SNR in subframes with 0 dB power boost (Note 2)		dB	3	4
$\hat{I}_{or}^{(j)}$ in subframes with 6 dB power		dB[mW/15kHz]	-89	-88
$\hat{I}_{or}^{(j)}$ in subframes with 0 dB power		dB[mW/15kHz]	-95	-94
$N_{oc}^{(j)}$		dB[mW/15kHz]	-98	
MBSFN subframe Configuration			Non-MBSFN	
Cell Id			0	
dmtd-Periodicity		ms	80	
dmtd-Offset			0	
Number of control OFDM symbols			3	
Max number of HARQ transmissions			1	
Reporting mode			PUSCH 3-0	
PDSCH transmission model	Basic model		As specified in Section B.8	
	subframeStartPosition		s0	
	Number of occupied symbols per subframe		14	
	The number of subframes set ( $S_1$ ) per burst		{3,8}	
	Random variable $p$ defined in B.8		0.5	
	Power configuration for each burst		$\hat{I}_{or}^{(j)}$ is randomly selected from 6 dB power boosting or 0 dB power boosting with equal probability	
Note 1: Reference measurement channel RC.2A FDD according to Table A.4-1 with one sided dynamic OCNG Pattern OP.1 FS3 as described in Annex A.5.4.1, except for category 1 UE use RC.4A FDD with two sided dynamic OCNG Pattern OP.2 FS3 as described in Annex A.5.4.2.				
Note 2: For each test, the minimum requirements shall be fulfilled for at least one of the two SNR(s) and the respective wanted signal input level.				

### 9.2.6.2 Frame structure type 3 with TDD Pcell

The following requirements apply to UE Category  $\geq 1$ . For the parameters specified in Table 9.2.6.2-1, Table 9.2.6.2-2, and using the downlink physical channels specified in tables C.3.2-1 and C.3.2-2, two sets of CQI reports are obtained for LAA Scell. The first one is obtained by reports whose reference resource is in the downlink subframes with 6 dB transmission power boost, i.e., high power subframes. The second one is obtained by reports whose reference resource is in the downlink subframe with 0 dB transmission power boost, i.e., low power subframe. In the test, PDSCH transport format in high power subframe is determined by first set of CQI reports and PDSCH transport format in low power subframe is determined by second set of CQI reports.

The reported CQI value in the first set of reports shall be in the range of  $\pm 1$  of the reported median more than 90% of the first set of reports. The reported CQI value in the second set of reports shall be in the range of  $\pm 1$  of the reported median more than 90% of the second set of reports.

If the PDSCH BLER in the high power subframes using the transport format indicated by wideband CQI median is less than or equal to 0.1, the BLER in high power subframes using the transport format indicated by the (wideband CQI median + 1) shall be greater than 0.1. If the PDSCH BLER in the high power subframes using the transport format indicated by the wideband CQI median is greater than 0.1, the BLER in high power subframes using transport format indicated by (wideband CQI median – 1) shall be less than or equal to 0.1.

If the PDSCH BLER in the low power subframes using the transport format indicated by wideband CQI median is less than or equal to 0.1, the BLER in low power subframes using the transport format indicated by the (wideband CQI median + 1) shall be greater than 0.1. If the PDSCH BLER in the low power subframes using the transport format indicated by the wideband CQI median is greater than 0.1, the BLER in low power subframes using transport format indicated by (wideband CQI median – 1) shall be less than or equal to 0.1.

The value of the wideband CQI median for first set of CQI reports minus the wideband CQI median for second set of CQI reports shall be larger than or equal to 2 in Test 1 and Test 2.

**Table 9.2.6.2-1: Parameters for PUSCH 3-0 static test on TDD Pcell**

Parameter	Unit	Value
Bandwidth	MHz	20
Uplink downlink configuration		2
Special subframe configuration		4
PDSCH transmission mode		3
Downlink power allocation	$\rho_A$	dB
	$\rho_B$	dB
	$\sigma$	dB
Propagation condition and antenna configuration		Clause B.1 (2 x 2)
SNR	dB	20
$\hat{I}_{or}^{(j)}$	dB[mW/15kHz]	-78
$N_{oc}^{(j)}$	dB[mW/15kHz]	-98
Max number of HARQ transmissions		1
Reporting mode		PUSCH 3-0
CSI request field		'10'
trigger1 (Note 2)		01000000
trigger2 (Note 2)		00000000
Note 1:	PCell is used for HARQ ACK/NACK feedback and aperiodic CSI triggering/reporting. One sided dynamic OCNG Pattern OP.1 TDD as described in A.5.2.1 is transmitted on PCell on all RBs, but PDSCH for user data is not transmitted on PCell.	
Note 2:	trigger1 and trigger2 are defined as TS 36.331 for aperiodicCSI-Trigger. They indicate for which serving cell(s) the aperiodic CSI report is triggered when one or more SCells are configured. PDCCH DCI format 0 with a trigger for aperiodic CQI is transmitted periodically in subframe 3 and subframe 8 with 5ms periodicity.	

Table 9.2.6.2-2: PUSCH 3-0 static test on LAA Scell

Parameter		Unit	Test 1	Test 2
Bandwidth		MHz	20	
PDSCH transmission mode			3	
Downlink power allocation	$\rho_A$	dB	-3	
	$\rho_B$	dB	-3	
	$\sigma$	dB	0	
Propagation condition and antenna configuration			Clause B.1 (2x2)	
SNR in subframes with 6 dB power boost (Note 2)		dB	9	10
SNR in subframes with 0 dB power boost (Note 2)		dB	3	4
$\hat{I}_{or}^{(j)}$ in subframes with 6 dB power		dB[mW/15kHz]	-89	-88
$\hat{I}_{or}^{(j)}$ in subframes with 0 dB power		dB[mW/15kHz]	-95	-94
$N_{oc}^{(j)}$		dB[mW/15kHz]	-98	
MBSFN subframe Configuration			Non-MBSFN	
Cell Id			0	
dmtd-Periodicity		ms	80	
dmtd-Offset			0	
Number of control OFDM symbols			3	
Max number of HARQ transmissions			1	
Reporting mode			PUSCH 3-0	
PDSCH transmission model	Basic model		As specified in Section B.7	
	subframeStartPosition		s0	
	Number of occupied symbols per subframe		14	
	The number of subframes set ( $S_1$ ) per burst		{3,8}	
	Random variable $p$ defined in B.8		0.5	
	Power configuration for each burst		$\hat{I}_{or}^{(j)}$ is randomly selected from 6 dB power boosting or 0 dB power boosting with equal probability	
Note 1: Reference measurement channel RC.2A FDD according to Table A.4-1 with one sided dynamic OCN Pattern OP.1 FS3 as described in Annex A.5.4.1, except for category 1 UE use RC.4A FDD with two sided dynamic OCN Pattern OP.2 FS3 as described in Annex A.5.4.2.				
Note 2: For each test, the minimum requirements shall be fulfilled for at least one of the two SNR(s) and the respective wanted signal input level.				

## 9.2.7 Minimum requirement PUSCH 3-1 (CSI Reference Symbol)

### 9.2.7.1 Frame structure type 3 with FDD Pcell

The following requirements apply to UE Category  $\geq 1$ . For the parameters specified in Table 9.2.7.1-1, Table 9.2.7.1-2 and using the downlink physical channels specified in tables C.3.2-1 and C.3.2-2, two sets of CQI reports are obtained for LAA Scell. The first one is obtained by reports whose reference resource is in the downlink subframes with 6 dB transmission power boost, i.e., high power subframes. The second one is obtained by reports whose reference resource is in the downlink subframe with 0 dB transmission power boost, i.e., low power subframe. In the test, PDSCH transport format in high power subframe is determined by first set of CQI reports and PDSCH transport format in low power subframe is determined by second set of CQI reports.

The reported CQI value in the first set of reports shall be in the range of  $\pm 1$  of the reported median more than 90% of the first set of reports. The reported CQI value in the second set of reports shall be in the range of  $\pm 1$  of the reported median more than 90% of the second set of reports.

If the PDSCH BLER in the high power subframes using the transport format indicated by wideband CQI median is less than or equal to 0.1, the BLER in low power subframes using the transport format indicated by the (wideband CQI median + 1) shall be greater than 0.1. If the PDSCH BLER in high power subframes using the transport format indicated by the wideband CQI median is greater than 0.1, the BLER in high power subframes using transport format indicated by (wideband CQI median - 1) shall be less than or equal to 0.1.

If the PDSCH BLER in the low power subframes using the transport format indicated by wideband CQI median is less than or equal to 0.1, the BLER in low power subframes using the transport format indicated by the (wideband CQI median + 1) shall be greater than 0.1. If the PDSCH BLER in the low power subframes using the transport format indicated by the wideband CQI median is greater than 0.1, the BLER in low power subframes using transport format indicated by (wideband CQI median - 1) shall be less than or equal to 0.1.

The value of the wideband CQI for the first set of CQI report minus the wideband CQI median for second set of CQI shall be larger than or equal to 2 in Test 1 and Test 2.

**Table 9.2.7.1-1: Parameters for PUSCH 3-1 static test on FDD Pcell**

Parameter	Unit	Value	
Bandwidth	MHz	20	
PDSCH transmission mode		9	
Downlink power allocation	$\rho_A$	dB	0
	$\rho_B$	dB	0
	$\rho_C$	dB	0
	$\sigma$	dB	0
Propagation condition and antenna configuration		Clause B.1 (2 x 2)	
SNR	dB	20	
$\hat{I}_{or}^{(j)}$	dB[mW/15kHz]	-78	
$N_{oc}^{(j)}$	dB[mW/15kHz]	-98	
CRS reference signals		Antenna ports 0	
CSI reference signals		Antenna ports 15, 16	
CSI-RS periodicity and subframe offset $T_{CSI-RS} / \Delta_{CSI-RS}$		5/ 1	
CSI-RS reference signal configuration		4	
CodeBookSubsetRestriction bitmap		000001	
Number of control OFDM symbols		3	
Max number of HARQ transmissions		1	
Reporting mode		PUSCH 3-1	
CSI request field		'10'	
trigger1 (Note 2)		01000000	
trigger2 (Note 2)		00000000	
Note 1:	PCell is used for HARQ ACK/NACK feedback and aperiodic CSI triggering/reporting. One sided dynamic OCNG Pattern OP.1 FDD as described in A.5.1.1 is transmitted on PCell on all RBs, but PDSCH for user data is not transmitted on PCell.		
Note 2:	trigger1 and trigger2 are defined as TS 36.331 for aperiodicCSI-Trigger. They Indicate for which serving cell(s) the aperiodic CSI report is triggered when one or more SCells are configured. PDCCH DCI format 0 with a trigger for aperiodic CQI is transmitted periodically in subframe 1 and subframe 6 with 5ms periodicity.		

Table 9.2.7.1-2: PUSCH 3-1 static test on LAA Scell

Parameter	Unit	Test 1	Test 2
Bandwidth	MHz	20 MHz	
Transmission mode		9	
Downlink power allocation	$\rho_A$	dB	0
	$\rho_B$	dB	0
	$P_C$	dB	0
	$\sigma$	dB	0
SNR in subframes with 6 dB power boost (Note 3)	dB	9	10
SNR in subframes with 0 dB power boost (Note 3)		3	4
$\hat{I}_{or}^{(j)}$ in subframes with 6 dB power		-89	-88
$\hat{I}_{or}^{(j)}$ in subframes with 0 dB power	dB[mW/15kHz]	-95	-94
$N_{oc}^{(j)}$	dB[mW/15kHz]	-98	-98
MBSFN subframe Configuration		Non-MBSFN	
Cell Id		0	
dmtc-Periodicity	ms	80	
dmtc-Offset		0	
Propagation condition and antenna configuration		Clause B.1 (2x2)	
Beamforming Model		As specified in Section B.4.3	
CRS reference signals		Antenna ports 0	
CSI reference signals		Antenna ports 15, 16	
CSI-RS periodicity and subframe offset $T_{CSI-RS} / \Delta_{CSI-RS}$		5/ 1	
CSI-RS reference signal configuration		4	
CodeBookSubsetRestriction bitmap		000001	
Number of control OFDM symbols		3	
Max number of HARQ transmissions		1	
Reporting mode		PUSCH 3-1	
PDSCH transmission model	Basic model	As specified in Section B.8	
	subframeStartPosition	s0	
	Number of occupied symbols per subframe	14	
	The number of subframes set ( $S_1$ ) per burst	{3, 8}	
	Random variable $p$ defined in B.8	0.5	
	Power configuration for each burst	$\hat{I}_{or}^{(j)}$ is randomly selected from 6 dB power boosting or 0 dB power boosting with equal probability	
Note 1:	If the UE reports in an available uplink reporting instance at subframe SF#n based on CQI estimation at a downlink subframe not later than SF#(n-4), this reported subband or wideband CQI cannot be applied at the eNB downlink before SF#(n+4)		
Note 2:	Reference measurement channel RC.9A FDD according to Table A.4-1 with one/two sided dynamic OCNG Pattern OP.1/2 FS3 as described in Annex A.5.4.1/2.		
Note 3:	For each test, the minimum requirements shall be fulfilled for at least one of the two SNR(s) and the respective wanted signal input level.		

### 9.2.7.2 Frame structure type 3 with TDD Pcell

The following requirements apply to UE Category  $\geq 1$ . For the parameters specified in Table 9.2.7.2-1, Table 9.2.7.2-2 and using the downlink physical channels specified in tables C.3.2-1 and C.3.2-2, two sets of CQI reports are obtained for LAA Scell, The first one is obtained by reports whose reference resource is in the downlink subframes with 6 dB transmission power boost, i.e., high power subframes. The second one is obtained by reports whose reference resource is



in the downlink subframe with 0 dB transmission power boost, i.e., low power subframe. In the test, PDSCH transport format in high power subframe is determined by first set of CQI reports and PDSCH transport format in low power subframe is determined by second set of CQI reports.

The reported CQI value in the first set of reports shall be in the range of  $\pm 1$  of the reported median more than 90% of the first set of reports. The reported CQI value in the second set of reports shall be in the range of  $\pm 1$  of the reported median more than 90% of the second set of reports.

If the PDSCH BLER in the high power subframes using the transport format indicated by wideband CQI median is less than or equal to 0.1, the BLER in high power subframes using the transport format indicated by the (wideband CQI median + 1) shall be greater than 0.1. If the PDSCH BLER in high power subframes using the transport format indicated by the wideband CQI median is greater than 0.1, the BLER in high power subframes using transport format indicated by (wideband CQI median - 1) shall be less than or equal to 0.1.

If the PDSCH BLER in the low power subframes using the transport format indicated by wideband CQI median is less than or equal to 0.1, the BLER in low power subframes using the transport format indicated by the (wideband CQI median + 1) shall be greater than 0.1. If the PDSCH BLER in the low power subframes using the transport format indicated by the wideband CQI median is greater than 0.1, the BLER in low power subframes using transport format indicated by (wideband CQI median - 1) shall be less than or equal to 0.1.

The value of the wideband CQI for the first set of CQI report minus the wideband CQI median for second set of CQI shall be larger than or equal to 2 in Test 1 and Test 2.

Table 9.2.7.2-1: Parameters for PUSCH 3-1 static test on TDD Pcell

Parameter	Unit	Value	
Bandwidth	MHz	20	
PDSCH transmission mode		9	
Uplink downlink configuration		2	
Special subframe configuration		4	
Downlink power allocation	$\rho_A$	dB	0
	$\rho_B$	dB	0
	$\rho_C$	dB	0
	$\sigma$	dB	0
Propagation condition and antenna configuration		Clause B.1 (2 x 2)	
SNR	dB	20	
$\hat{I}_{of}^{(j)}$	dB[mW/15kHz]	-78	
$N_{oc}^{(j)}$	dB[mW/15kHz]	-98	
CRS reference signals		Antenna ports 0	
CSI reference signals		Antenna ports 15, 16	
CSI-RS periodicity and subframe offset $T_{CSI-RS} / \Delta_{CSI-RS}$		5/ 1	
CSI-RS reference signal configuration		4	
CodeBookSubsetRestriction bitmap		000001	
Number of control OFDM symbols		3	
Max number of HARQ transmissions		1	
Reporting mode		PUSCH 3-1	
CSI request field		'10'	
trigger1 (Note 2)		01000000	
trigger2 (Note 2)		00000000	
Note 1:	PCell is used for HARQ ACK/NACK feedback and aperiodic CSI triggering/reporting. One sided dynamic OCNG Pattern OP.1 TDD as described in A.5.2.1 is transmitted on PCell on all RBs, but PDSCH for user data is not transmitted on PCell.		
Note 2:	trigger1 and trigger2 are defined as TS 36.331 for aperiodicCSI-Trigger. They Indicate for which serving cell(s) the aperiodic CSI report is triggered when one or more SCells are configured. PDCCH DCI format 0 with a trigger for aperiodic CQI is transmitted periodically in subframe 3 and subframe 8 with 5ms periodicity.		

Table 9.2.7.2-2: PUSCH 3-1 static test on LAA Scell

Parameter	Unit	Test 1	Test 2
Bandwidth	MHz	20 MHz	
Transmission mode		9	
Downlink power allocation	$\rho_A$	dB	0
	$\rho_B$	dB	0
	$P_C$	dB	0
	$\sigma$	dB	0
SNR in subframes with 6 dB power boost (Note 3)	dB	9	10
SNR in subframes with 0 dB power boost (Note 3)		3	4
$\hat{I}_{or}^{(j)}$ in subframes with 6 dB power		-89	-88
$\hat{I}_{or}^{(j)}$ in subframes with 0 dB power	dB[mW/15kHz]	-95	-94
$N_{oc}^{(j)}$	dB[mW/15kHz]	-98	-98
MBSFN subframe Configuration		Non-MBSFN	
Cell Id		0	
dmtc-Periodicity	ms	80	
dmtc-Offset		0	
Propagation condition and antenna configuration		Clause B.1 (2x2)	
Beamforming Model		As specified in Section B.4.3	
CRS reference signals		Antenna ports 0	
CSI reference signals		Antenna ports 15, 16	
CSI-RS periodicity and subframe offset $T_{CSI-RS} / \Delta_{CSI-RS}$		5/3	
CSI-RS reference signal configuration		4	
CodeBookSubsetRestriction bitmap		000001	
Number of control OFDM symbols		3	
Max number of HARQ transmissions		1	
Reporting mode		PUSCH 3-1	
PDSCH transmission model	Basic model	As specified in Section B.8	
	subframeStartPosition	s0	
	Number of occupied symbols per subframe	14	
	The number of subframes set ( $S_1$ ) per burst	{3, 8}	
	Random variable $p$ defined in B.8	0.5	
	Power configuration for each burst	$\hat{I}_{or}^{(j)}$ is randomly selected from 6 dB power boosting or 0 dB power boosting with equal probability	
Note 1:	If the UE reports in an available uplink reporting instance at subframe SF#n based on CQI estimation at a downlink subframe not later than SF#(n-4), this reported subband or wideband CQI cannot be applied at the eNB downlink before SF#(n+4)		
Note 2:	Reference measurement channel RC.9A FDD according to Table A.4-1 with one/two sided dynamic OCNG Pattern OP.1/2 FS3 as described in Annex A.5.4.1/2.		
Note 3:	For each test, the minimum requirements shall be fulfilled for at least one of the two SNR(s) and the respective wanted signal input level.		

## 9.3 CQI reporting under fading conditions

### 9.3.1 Frequency-selective scheduling mode

The accuracy of sub-band channel quality indicator (CQI) reporting under frequency selective fading conditions is determined by a double-sided percentile of the reported differential CQI offset level 0 per sub-band, and the relative increase of the throughput obtained when transmitting on a randomly selected sub-band among the sub-bands with the highest reported differential CQI offset level the corresponding transport format compared to the case for which a fixed format is transmitted on any sub-band in set  $S$  of TS 36.213 [6]. The purpose is to verify that preferred sub-bands can be used for frequently-selective scheduling. To account for sensitivity of the input SNR the sub-band CQI reporting under frequency selective fading conditions is considered to be verified if the reporting accuracy is met for at least one of two SNR levels separated by an offset of 1 dB.

#### 9.3.1.1 Minimum requirement PUSCH 3-0 (Cell-Specific Reference Symbols)

##### 9.3.1.1.1 FDD

For the parameters specified in Table 9.3.1.1.1-1, and using the downlink physical channels specified in Annex C.3.2, the minimum requirements are specified in Table 9.3.1.1.1-2 and by the following

- a) a sub-band differential CQI offset level of 0 shall be reported at least  $\alpha\%$  of the time but less than  $\beta\%$  for each sub-band;
- b) the ratio of the throughput obtained when transmitting on a randomly selected sub-band among the sub-bands with the highest differential CQI offset level the corresponding TBS and that obtained when transmitting the TBS indicated by the reported wideband CQI median on a randomly selected sub-band in set  $S$  shall be  $\geq \gamma$ ;
- c) when transmitting on a randomly selected sub-band among the sub-bands with the highest differential CQI offset level the corresponding TBS, the average BLER for the indicated transport formats shall be greater or equal to 0.05.

The requirements only apply for sub-bands of full size and the random scheduling across the sub-bands is done by selecting a new sub-band in each TTI for FDD, each available downlink transmission instance for TDD.

**Table 9.3.1.1.1-1 Sub-band test for single antenna transmission (FDD)**

Parameter		Unit	Test 1		Test 2	
Bandwidth		MHz	10 MHz			
Transmission mode			1 (port 0)			
Downlink power allocation	$\rho_A$	dB	0			
	$\rho_B$	dB	0			
	$\sigma$	dB	0			
SNR (Note 3)		dB	9	10	14	15
$\hat{I}_{or}^{(j)}$		dB[mW/15kHz]	-89	-88	-84	-83
$N_{oc}^{(j)}$		dB[mW/15kHz]	-98		-98	
Propagation channel			Clause B.2.4 with $\tau_d = 0.45 \mu\text{s}$ , $a = 1$ , $f_D = 5 \text{ Hz}$			
Antenna configuration			1 x 2			
Reporting interval		ms	5			
CQI delay		ms	8			
Reporting mode			PUSCH 3-0			
Sub-band size		RB	6 (full size)			
Max number of HARQ transmissions			1			
<p>Note 1: If the UE reports in an available uplink reporting instance at subframe SF#n based on CQI estimation at a downlink subframe not later than SF#(n-4), this reported subband or wideband CQI cannot be applied at the eNB downlink before SF#(n+4)</p> <p>Note 2: Reference measurement channel RC.3 FDD according to Table A.4-1 with one/two sided dynamic OCNG Pattern OP.1/2 FDD as described in Annex A.5.1.1/2.</p> <p>Note 3: For each test, the minimum requirements shall be fulfilled for at least one of the two SNR(s) and the respective wanted signal input level.</p>						

**Table 9.3.1.1.1-2 Minimum requirement (FDD)**

	Test 1	Test 2
$\alpha$ [%]	2	2
$\beta$ [%]	55	55
$\gamma$	1.1	1.1
UE Category	$\geq 1$	$\geq 1$

### 9.3.1.1.2 TDD

For the parameters specified in Table 9.3.1.1.2-1, and using the downlink physical channels specified in Annex C.3.2, the minimum requirements are specified in Table 9.3.1.1.2-2 and by the following

- a sub-band differential CQI offset level of 0 shall be reported at least  $\alpha\%$  of the time but less than  $\beta\%$  for each sub-band;
- the ratio of the throughput obtained when transmitting on a randomly selected sub-band among the sub-bands with the highest differential CQI offset level the corresponding TBS and that obtained when transmitting the TBS indicated by the reported wideband CQI median on a randomly selected sub-band in set  $S$  shall be  $\geq \gamma$ ;
- when transmitting on a randomly selected sub-band among the sub-bands with the highest differential CQI offset level the corresponding TBS, the average BLER for the indicated transport formats shall be greater or equal to 0.05.

The requirements only apply for sub-bands of full size and the random scheduling across the sub-bands is done by selecting a new sub-band in each TTI for FDD, each available downlink transmission instance for TDD.

Table 9.3.1.1.2-1 Sub-band test for single antenna transmission (TDD)

Parameter	Unit	Test 1		Test 2	
Bandwidth	MHz	10 MHz			
Transmission mode		1 (port 0)			
Downlink power allocation	$\rho_A$	dB			
	$\rho_B$	dB			
	$\sigma$	dB			
Uplink downlink configuration		2			
Special subframe configuration		4			
SNR (Note 3)	dB	9	10	14	15
$\hat{I}_{or}^{(j)}$	dB[mW/15kHz]	-89	-88	-84	-83
$N_{oc}^{(j)}$	dB[mW/15kHz]	-98		-98	
Propagation channel		Clause B.2.4 with $\tau_d = 0.45$ $\mu s, a = 1, f_D = 5$ Hz			
Antenna configuration		1 x 2			
Reporting interval	ms	5			
CQI delay	ms	10 or 11			
Reporting mode		PUSCH 3-0			
Sub-band size	RB	6 (full size)			
Max number of HARQ transmissions		1			
ACK/NACK feedback mode		Multiplexing			
Note 1:	If the UE reports in an available uplink reporting instance at subframe SF#n based on CQI estimation at a downlink subframe not later than SF#(n-4), this reported subband or wideband CQI cannot be applied at the eNB downlink before SF#(n+4)				
Note 2:	Reference measurement channel RC.3 TDD according to Table A.4-1 with one/two sided dynamic OCNB Pattern OP.1/2 TDD as described in Annex A.5.2.1/2.				
Note 3:	For each test, the minimum requirements shall be fulfilled for at least one of the two SNR(s) and the respective wanted signal input level.				

Table 9.3.1.1.2-2 Minimum requirement (TDD)

	Test 1	Test 2
$\alpha$ [%]	2	2
$\beta$ [%]	55	55
$\gamma$	1.1	1.1
UE Category	$\geq 1$	$\geq 1$

### 9.3.1.1.3 FDD (CSI measurements in case two CSI subframe sets are configured and with CRS assistance information)

For the parameters specified in Table 9.3.1.1.3-1, and using the downlink physical channels specified in Annex C.3.2, the minimum requirements are specified in Table 9.3.1.1.3-2 and by the following

- a sub-band differential CQI offset level of 0 shall be reported at least  $\alpha\%$  of the time but less than  $\beta\%$  for each sub-band;
- the ratio of the throughput in ABS subframes obtained when transmitting on a randomly selected sub-band among the sub-bands with the highest differential CQI offset level the corresponding TBS and that obtained when transmitting the TBS indicated by the reported wideband CQI median on a randomly selected sub-band in set  $S$  shall be  $\geq \gamma$ ;

- c) when transmitting on a randomly selected sub-band among the sub-bands with the highest differential CQI offset level the corresponding TBS, the average BLER in ABS subframes for the indicated transport formats shall be greater than or equal to  $\epsilon$ .

The requirements only apply for sub-bands of full size and the random scheduling across the sub-bands is done by selecting a new sub-band in each TTI for FDD, each available downlink transmission instance for TDD.

**Table 9.3.1.1.3-1 Sub-band test for single antenna transmission (FDD)**



Parameter	Unit	Test 1		Test 2	
		Cell 1	Cell 2 and 3	Cell 1	Cell 2 and 3
Bandwidth	MHz	10		10	
PDSCH transmission mode		1	Note 10	1	Note 10
Downlink power allocation	$\rho_A$	0		0	
	$\rho_B$	0		0	
	$\sigma$	0		0	
Propagation condition		Clause B.2.4 with $T_d = 0.45$ us, $a = 1$ , $f_d = 5$ Hz	EVA5 Low antenna correlation	Clause B.2.4 with $T_d = 0.45$ us, $a = 1$ , $f_d = 5$ Hz	EVA5 Low antenna correlation
Antenna configuration		1x2		1x2	
$E_s/N_{oc2}$ (Note 1)	dB	4	5	14	15
$N_{oc}^{(j)}$ at antenna port	$N_{oc1}^{(j)}$	-98 (Note 7)	N/A	-98 (Note 7)	N/A
	$N_{oc2}^{(j)}$	-98 (Note 8)	N/A	-98 (Note 8)	N/A
	$N_{oc3}^{(j)}$	-93 (Note 9)	N/A	-93 (Note 9)	N/A
Subframe Configuration		Non-MBSFN	Non-MBSFN	Non-MBSFN	Non-MBSFN
Cell Id		0	Cell 2: 6 Cell 3: 1	0	Cell 2: 6 Cell 3: 1
Time Offset between Cells	$\mu$ s	Cell 2: 3 usec Cell 3: -1usec		Cell 2: 3 usec Cell 3: -1usec	
Frequency Shift between Cells	Hz	Cell 2: 300Hz Cell 3: -100Hz		Cell 2: 300Hz Cell 3: -100Hz	
ABS pattern (Note 2)		N/A	01010101 01010101 01010101 01010101 01010101	N/A	01010101 01010101 01010101 01010101 01010101
RLM/RRM Measurement Subframe Pattern (Note 4)		00000100 00000100 00000100 00000100 00000100	N/A	00000100 00000100 00000100 00000100 00000100	N/A
CSI Subframe Sets (Note 3)	$C_{csi,0}$	01010101 01010101 01010101 01010101 01010101	N/A	01010101 01010101 01010101 01010101 01010101	N/A
	$C_{csi,1}$	10101010 10101010 10101010 10101010 10101010	N/A	10101010 10101010 10101010 10101010 10101010	N/A
Number of control OFDM symbols		3		3	
Max number of HARQ transmissions		1		1	
CQI delay	ms	8			
Reporting interval (Note 13)	ms	10			
Reporting mode		PUSCH 3-0			
Sub-band size	RB	6 (full size)			

Note 1:	For each test, the minimum requirements shall be fulfilled for at least one of the two SNR(s) and the respective wanted signal input level.
Note 2:	ABS pattern as defined in [9]. PDSCH other than SIB1/paging and its associated PDCCH/PCFICH are transmitted in the serving cell subframe when the subframe is overlapped with the ABS subframe of aggressor cell and the subframe is available in the definition of the reference channel.
Note 3:	Time-domain measurement resource restriction pattern for PCell measurements as defined in [7]
Note 4:	As configured according to the time-domain measurement resource restriction pattern for CSI measurements defined in [7]
Note 5:	Time-domain measurement resource restriction pattern for PCell measurements as defined in [7]
Note 6:	Cell 1 is the serving cell. Cell 2 and Cell 3 are the aggressor cells. The number of the CRS ports in Cell1, Cell2, and Cell3 are the same.
Note 7:	This noise is applied in OFDM symbols #1, #2, #3, #5, #6, #8, #9, #10, #12, #13 of a subframe overlapping with the aggressor ABS.
Note 8:	This noise is applied in OFDM symbols #0, #4, #7, #11 of a subframe overlapping with the aggressor ABS.
Note 9:	This noise is applied in all OFDM symbols of a subframe overlapping with aggressor non-ABS.
Note 10:	Downlink physical channel setup in Cell 2 and Cell 3 in accordance with Annex C.3.3 applying OCNB pattern as defined in Annex A.5.1.5
Note 11:	Reference measurement channel in Cell 1 RC.3 FDD according to Table A.4-1 with one/two sided dynamic OCNB Pattern OP.1/2 FDD as described in Annex A.5.1.1/2.
Note 12:	If the UE reports in an available uplink reporting instance at subframe SF#n based on CQI estimation at a downlink subframe not later than SF#(n-4), this reported subband or wideband CQI cannot be applied at the eNB downlink before SF#(n+4).
Note 13:	The CSI reporting is such that reference subframes belong to $C_{csi,0}$ .

**Table 9.3.1.1.3-2 Minimum requirement (FDD)**

	Test 1	Test 2
$\alpha$ [%]	2	2
$\beta$ [%]	55	55
$\gamma$	1.1	1.1
$\epsilon$	0.01	0.01
UE Category	$\geq 1$	$\geq 1$

#### 9.3.1.1.4 TDD (CSI measurements in case two CSI subframe sets are configured and with CRS assistance information)

For the parameters specified in Table 9.3.1.1.4-1, and using the downlink physical channels specified in Annex C.3.2, the minimum requirements are specified in Table 9.3.1.1.4-2 and by the following

- a sub-band differential CQI offset level of 0 shall be reported at least  $\alpha\%$  of the time but less than  $\beta\%$  for each sub-band;
- the ratio of the throughput in ABS subframes obtained when transmitting on a randomly selected sub-band among the sub-bands with the highest differential CQI offset level the corresponding TBS and that obtained when transmitting the TBS indicated by the reported wideband CQI median on a randomly selected sub-band in set  $S$  shall be  $\geq \gamma$ ;
- when transmitting on a randomly selected sub-band among the sub-bands with the highest differential CQI offset level the corresponding TBS, the average BLER in ABS subframes for the indicated transport formats shall be greater than or equal to  $\epsilon$ .

The requirements only apply for sub-bands of full size and the random scheduling across the sub-bands is done by selecting a new sub-band in each TTI for FDD, each available downlink transmission instance for TDD.

**Table 9.3.1.1.4-1: Sub-band test for single antenna transmission (TDD)**

Parameter	Unit	Test 1		Test 2			
		Cell 1	Cell 2 and 3	Cell 1	Cell 2 and 3		
Bandwidth	MHz	10		10			
PDSCH transmission mode		1	Note 10	1	Note 10		
Uplink downlink configuration		1		1			
Special subframe configuration		4		4			
Downlink power allocation	$\rho_A$	dB		0			
	$\rho_B$	dB		0			
	$\sigma$	dB		0			
Propagation condition		Clause B.2.4 with $T_d = 0.45$ us, $a = 1$ , $f_d = 5$ Hz	EVA5 Low antenna correlation	Clause B.2.4 with $T_d = 0.45$ us, $a = 1$ , $f_d = 5$ Hz	EVA5 Low antenna correlation		
Antenna configuration		1x2		1x2			
$E_s/N_{oc2}$ (Note 1)	dB	4	5	Cell 2: 12 Cell 3: 10	14	15	Cell 2: 12 Cell 3: 10
$N_{oc}^{(j)}$ at antenna port	$N_{oc1}^{(j)}$	dBm/15kHz	-98 (Note 7)	N/A	-98 (Note 7)	N/A	
	$N_{oc2}^{(j)}$	dBm/15kHz	-98 (Note 8)	N/A	-98 (Note 8)	N/A	
	$N_{oc3}^{(j)}$	dBm/15kHz	-93 (Note 9)	N/A	-93 (Note 9)	N/A	
Subframe Configuration		Non-MBSFN	Non-MBSFN	Non-MBSFN	Non-MBSFN		
Cell Id		0	Cell 2: 6 Cell 3: 1	0	Cell 2: 6 Cell 3: 1		
Time Offset between Cells	$\mu$ s	Cell 2: 3 usec Cell 3: -1usec		Cell 2: 3 usec Cell 3: -1usec			
Frequency shift between Cells	Hz	Cell 2: 300Hz Cell 3: -100Hz		Cell 2: 300Hz Cell 3: -100Hz			
ABS pattern (Note 2)		N/A	0100010001 0100010001	N/A	0100010001 0100010001		
RLM/RRM Measurement Subframe Pattern (Note 4)		0000000001 0000000001	N/A	0000000001 0000000001	N/A		
CSI Subframe Sets (Note 3)	$C_{CSI,0}$	0100010001 0100010001	N/A	0100010001 0100010001	N/A		
	$C_{CSI,1}$	1000101000 1000101000	N/A	1000101000 1000101000	N/A		
Number of control OFDM symbols		3		3			
Max number of HARQ transmissions		1		1			
CQI delay	ms	10					
Reporting interval (Note 13)	ms	10					
Reporting mode		PUSCH 3-0					
Sub-band size	RB	6 (full size)					
ACK/NACK feedback mode		Multiplexing		Multiplexing			

Note 1:	For each test, the minimum requirements shall be fulfilled for at least one of the two SNR(s) and the respective wanted signal input level.
Note 2:	ABS pattern as defined in [9]. PDSCH other than SIB1/paging and its associated PDCCH/PCFICH are transmitted in the serving cell subframe when the subframe is overlapped with the ABS subframe of aggressor cell and the subframe is available in the definition of the reference channel.
Note 3:	Time-domain measurement resource restriction pattern for PCell measurements as defined in [7]
Note 4:	As configured according to the time-domain measurement resource restriction pattern for CSI measurements defined in [7].
Note 5:	Time-domain measurement resource restriction pattern for PCell measurements as defined in [7]
Note 6:	Cell 1 is the serving cell. Cell 2 and Cell 3 are the aggressor cells. The number of the CRS ports in Cell1, Cell2, and Cell3 is the same.
Note 7:	This noise is applied in OFDM symbols #1, #2, #3, #5, #6, #8, #9, #10, #12, #13 of a subframe overlapping with the aggressor ABS.
Note 8:	This noise is applied in OFDM symbols #0, #4, #7, #11 of a subframe overlapping with the aggressor ABS
Note 9:	This noise is applied in all OFDM symbols of a subframe overlapping with aggressor non-ABS.
Note 10:	Downlink physical channel setup in Cell 2 and Cell 3 in accordance with Annex C.3.3 applying OCNG pattern as defined in Annex A.5.2.5
Note 11:	Reference measurement channel in Cell 1 RC.3 TDD according to Table A.4-1 with one/two sided dynamic OCNG Pattern OP.1/2 TDD as described in Annex A.5.2.1/2.
Note 12:	If the UE reports in an available uplink reporting instance at subframe SF#n based on CQI estimation at a downlink subframe not later than SF#(n-4), this reported subband or wideband CQI cannot be applied at the eNB downlink before SF#(n+4).
Note 13:	The CSI reporting is such that reference subframes belong to $C_{csi,0}$ .

**Table 9.3.1.1.4-2 Minimum requirement (TDD)**

	Test 1	Test 2
$\alpha$ [%]	2	2
$\beta$ [%]	55	55
$\gamma$	1.1	1.1
$\epsilon$	0.01	0.01
UE Category	$\geq 1$	$\geq 1$

#### 9.3.1.1.5 TDD (when *csi-SubframeSet-r12* is configured)

The following requirements apply to UE Category  $\geq 1$  which supports Rel-12 CSI subframe sets. For the parameters specified in Table 9.3.1.1.5-1, and using the downlink physical channels specified in Annex C.3.2, the minimum requirements are specified in Table 9.3.1.1.5-2 and by the following

- a sub-band differential CQI offset level of 0 shall be reported at least  $\alpha\%$  of the time but less than  $\beta\%$  for each sub-band for each CSI subframe set;
- the ratio of the throughput obtained when transmitting on a randomly selected sub-band among the sub-bands with the highest differential CQI offset level the corresponding TBS and that obtained when transmitting the TBS indicated by the reported wideband CQI median on a randomly selected sub-band in set  $S$  shall be  $\geq \gamma$  for each CSI subframe set;
- when transmitting on a randomly selected sub-band among the sub-bands with the highest differential CQI offset level the corresponding TBS, the average BLER for the indicated transport formats shall be greater or equal to 0.05 and less than 0.60 for each CSI subframe set.
- the difference of the wide-band median CQI obtained by reports in CSI subframe sets  $C_{CSI,0}$  and the wide-band median CQI obtained by reports in CSI subframe sets  $C_{CSI,1}$  shall be larger than or equal to 3.

The requirements only apply for sub-bands of full size and the random scheduling across the sub-bands is done by selecting a new sub-band in each available downlink transmission instance. Sub-bands of a size smaller than full size are excluded from the test.

Table 9.3.1.1.5-1: Sub-band test for TDD

Parameter	Unit	Test	
Bandwidth	MHz	10	
Transmission mode		2	
Uplink downlink configuration		2	
Special subframe configuration		4	
CSI-MeasSubframeSet-r12		0001100000	
Downlink power allocation	$\rho_A$	dB	-3
	$\rho_B$	dB	-3
	$\sigma$	dB	0
SNR in CSI subframe set 0	dB	0	1
SNR in CSI subframe set 1	dB	10	11
$\hat{I}_{or}^{(j)}$	dB[mW/15kHz]	-98	-97
$N_{oc1}^{(j)}$ for CSI subframe set 0	dB[mW/15kHz]	-98	-98
$N_{oc2}^{(j)}$ for CSI subframe set 1	dB[mW/15kHz]	-108	-108
Propagation channel		Clause B.2.4 with $\tau_d = 0.45$ $\mu s, a = 1, f_D = 5$ Hz	
Antenna configuration		2x2	
CRS reference signals		Antenna port 0 and 1	
Zero-Power CSI-RS configuration 0 $l_{CSI-RS} / ZeroPowerCSI-RS$ bitmap		3 / 0000010000000000	
Zero-Power CSI-RS configuration 1 $l_{CSI-RS} / ZeroPowerCSI-RS$ bitmap		4 / 0100000000000000	
PDSCH scheduled subframes for CSI subframe set 0		8,9	
PDSCH scheduled subframes for CSI subframe set 1		3,4	
Reporting interval (Note 4)	ms	10 per subframe set	
CQI delay	ms	15 for CSI subframe set 0 15 for CSI subframe set 1	
Reporting mode		PUSCH 3-0	
Sub-band size	RB	6 (full size)	
Max number of HARQ transmissions		1	
ACK/NACK feedback mode		Multiplexing	
Number of EPDCCH Sets Configured		2 (Note 5,6)	
Number of PRB per EPDCCH Set		4	
EPDCCH Subframe Monitoring		NA	
EPDCCH Aggregation level		8ECCE	
EPDCCH beamforming model		Annex B.4.4	
Note 1:	If the UE reports in an available uplink reporting instance at subframe SF#n based on CQI estimation at a downlink subframe not later than SF#(n-4), this reported subband or wideband CQI cannot be applied at the eNB downlink before SF#(n+4)		
Note 2:	Reference measurement channel RC.17 TDD according to Table A.4-1 with one/two sided dynamic OCNG Pattern OP.1/2 TDD as described in Annex A.5.2.1/2.		
Note 3:	In the test, the minimum requirements shall be fulfilled for at least one of the two SNR(s) and the respective wanted signal input level for each subframe set separately..		
Note 4:	For CSI subframe set 0, PDCCH DCI format 0 with a trigger for aperiodic CQI shall be transmitted in downlink SF#3 to allow aperiodic CQI/PMI/RI to be transmitted on uplink SF #7. For CSI subframe set 1, PDCCH DCI format 0 with a trigger for aperiodic CQI shall be transmitted in downlink SF#8 to allow aperiodic CQI/PMI/RI to be transmitted on uplink SF#2.		
Note 5:	In case UE supports EPDCCH, the PDSCH scheduling grants are transmitted via EPDCCH, otherwise PDCCH is used.		
Note 6:	The two sets are distributed EPDCCH sets and non-overlapping with PRB = {0, 3, 6, 9} for the first set and PRB = {40, 43, 46, 49} for the second set. EPDCCH set is selected after scheduling decision for PDSCH to avoid collision between PDSCH and EPDCCH PRBs, respectively. EPDCCH is only transmitted from one set. The starting symbol for EPDCCH is derived from the PCFICH. RRC signalling epdcch-StartSymbol-r11 is not configured		

**Table 9.3.1.1.5-2: Minimum requirement (TDD)**

	Test
$\alpha$ [%]	2
$\beta$ [%]	55
$\gamma$	1.1
UE Category	$\geq 1$

### 9.3.1.2 Minimum requirement PUSCH 3-1 (CSI Reference Symbol)

#### 9.3.1.2.1 FDD

For the parameters specified in Table 9.3.1.2.1-1, and using the downlink physical channels specified in Annex C.3.2, the minimum requirements are specified in Table 9.3.1.2.1-2 and by the following

- a) a sub-band differential CQI offset level of 0 shall be reported at least  $\alpha\%$  of the time but less than  $\beta\%$  for each sub-band;
- b) the ratio of the throughput obtained when transmitting on a randomly selected sub-band among the sub-bands with the highest differential CQI offset level the corresponding TBS and that obtained when transmitting the TBS indicated by the reported wideband CQI median on a randomly selected sub-band in set  $S$  shall be  $\geq \gamma$ ;
- c) when transmitting on a randomly selected sub-band among the sub-bands with the highest differential CQI offset level the corresponding TBS, the average BLER for the indicated transport formats shall be greater or equal to 0.05.

The requirements only apply for sub-bands of full size and the random scheduling across the sub-bands is done by selecting a new sub-band in each TTI for FDD, each available downlink transmission instance for TDD. Sub-bands of a size smaller than full size are excluded from the test.

Table 9.3.1.2.1-1 Sub-band test for FDD

Parameter	Unit	Test 1		Test 2	
Bandwidth	MHz	10 MHz			
Transmission mode		9			
Downlink power allocation	$\rho_A$	0			
	$\rho_B$	0			
	$\rho_C$	0			
	$\sigma$	0			
SNR (Note 3)	dB	4	5	11	12
$\hat{I}_{or}^{(j)}$	dB[mW/15kHz]	-94	-93	-87	-86
$N_{oc}^{(j)}$	dB[mW/15kHz]	-98		-98	
Propagation channel		Clause B.2.4 with $\tau_d = 0.45$ $\mu s$ , $a = 1$ , $f_D = 5$ Hz			
Antenna configuration		2x2			
Beamforming Model		As specified in Section B.4.3			
CRS reference signals		Antenna ports 0			
CSI reference signals		Antenna ports 15, 16			
CSI-RS periodicity and subframe offset $T_{CSI-RS} / \Delta_{CSI-RS}$		5 / 1			
CSI-RS reference signal configuration		4			
CodeBookSubsetRestriction bitmap		000001			
Reporting interval (Note 4)	ms	5			
CQI delay	ms	8			
Reporting mode		PUSCH 3-1			
Sub-band size	RB	6 (full size)			
Max number of HARQ transmissions		1			
Note 1:	If the UE reports in an available uplink reporting instance at subframe SF#n based on CQI estimation at a downlink subframe not later than SF#(n-4), this reported subband or wideband CQI cannot be applied at the eNB downlink before SF#(n+4)				
Note 2:	Reference measurement channel RC.8 FDD according to Table A.4-1 with one/two sided dynamic OCNG Pattern OP.1/2 FDD as described in Annex A.5.1.1/2.				
Note 3:	For each test, the minimum requirements shall be fulfilled for at least one of the two SNR(s) and the respective wanted signal input level.				
Note 4:	PDCCH DCI format 0 with a trigger for aperiodic CQI shall be transmitted in downlink SF#1 and #6 to allow aperiodic CQI/PMI/RI to be transmitted in uplink SF#0 and #5.				

Table 9.3.1.2.1-2 Minimum requirement (FDD)

	Test 1	Test 2
$\alpha$ [%]	2	2
$\beta$ [%]	40	40
$\gamma$	1.1	1.1
UE Category	$\geq 1$	$\geq 1$

## 9.3.1.2.2 TDD

For the parameters specified in Table 9.3.1.2.2-1, and using the downlink physical channels specified in Annex C.3.2, the minimum requirements are specified in Table 9.3.1.2.2-2 and by the following

- a sub-band differential CQI offset level of 0 shall be reported at least  $\alpha\%$  of the time but less than  $\beta\%$  for each sub-band;
- the ratio of the throughput obtained when transmitting on a randomly selected sub-band among the sub-bands with the highest differential CQI offset level the corresponding TBS and that obtained when transmitting the TBS indicated by the reported wideband CQI median on a randomly selected sub-band in set  $S$  shall be  $\geq \gamma$ ;



- c) when transmitting on a randomly selected sub-band among the sub-bands with the highest differential CQI offset level the corresponding TBS, the average BLER for the indicated transport formats shall be greater or equal to 0.05.

The requirements only apply for sub-bands of full size and the random scheduling across the sub-bands is done by selecting a new sub-band in each TTI for FDD, each available downlink transmission instance for TDD. Sub-bands of a size smaller than full size are excluded from the test.

**Table 9.3.1.2.2-1 Sub-band test for TDD**

Parameter	Unit	Test 1		Test 2	
Bandwidth	MHz	10 MHz			
Transmission mode		9			
Uplink downlink configuration		2			
Special subframe configuration		4			
Downlink power allocation	$\rho_A$	dB		0	
	$\rho_B$	dB		0	
	$\rho_C$	dB		0	
	$\sigma$	dB		0	
SNR (Note 3)	dB	4	5	11	12
$\hat{I}_{or}^{(j)}$	dB[mW/15kHz]	-94	-93	-87	-86
$N_{oc}^{(j)}$	dB[mW/15kHz]	-98		-98	
Propagation channel		Clause B.2.4 with $\tau_d = 0.45$ $\mu s, a = 1, f_D = 5$ Hz			
Antenna configuration		2x2			
Beamforming Model		As specified in Section B.4.3			
CRS reference signals		Antenna port 0			
CSI reference signals		Antenna port 15,16			
CSI-RS periodicity and subframe offset $T_{CSI-RS} / \Delta_{CSI-RS}$		5/3			
CSI-RS reference signal configuration		4			
CodeBookSubsetRestriction bitmap		000001			
Reporting interval (Note 4)	ms	5			
CQI delay	ms	10			
Reporting mode		PUSCH 3-1			
Sub-band size	RB	6 (full size)			
Max number of HARQ transmissions		1			
ACK/NACK feedback mode		Multiplexing			
Note 1:	If the UE reports in an available uplink reporting instance at subframe SF#n based on CQI estimation at a downlink subframe not later than SF#(n-4), this reported subband or wideband CQI cannot be applied at the eNB downlink before SF#(n+4)				
Note 2:	Reference measurement channel RC.8 TDD according to Table A.4-1 with one/two sided dynamic OCNG Pattern OP.1/2 TDD as described in Annex A.5.2.1/2.				
Note 3:	For each test, the minimum requirements shall be fulfilled for at least one of the two SNR(s) and the respective wanted signal input level.				
Note 4:	PDCCH DCI format 0 with a trigger for aperiodic CQI shall be transmitted in downlink SF#3 and #8 to allow aperiodic CQI/PMI/RI to be transmitted on uplink SF#2 and #7.				

**Table 9.3.1.2.2-2 Minimum requirement (TDD)**

	Test 1	Test 2
$\alpha$ [%]	2	2
$\beta$ [%]	40	40
$\gamma$	1.1	1.1
UE Category	$\geq 1$	$\geq 1$

### 9.3.1.2.3 FDD (Modulation and TBS index Table 2 and 4-bit CQI Table 2 are used)

For the parameters specified in Table 9.3.1.2.3-1, and using the downlink physical channels specified in Annex C.3.2, the minimum requirements are specified in Table 9.3.1.2.3-2 and by the following

- a) a sub-band differential CQI offset level of 0 shall be reported at least  $\alpha\%$  of the time but less than  $\beta\%$  for each sub-band;
- b) the ratio of the throughput obtained when transmitting on a randomly selected sub-band among the sub-bands with the highest differential CQI offset level the corresponding TBS and that obtained when transmitting the TBS indicated by the reported wideband CQI median on a randomly selected sub-band in set  $S$  shall be  $\geq \gamma$ ;
- c) when transmitting on a randomly selected sub-band among the sub-bands with the highest differential CQI offset level the corresponding TBS, the average BLER for the indicated transport formats shall be greater or equal to 0.05.

The requirements only apply for sub-bands of full size and the random scheduling across the sub-bands is done by selecting a new sub-band in each TTI for FDD, each available downlink transmission instance for TDD. Sub-bands of a size smaller than full size are excluded from the test.

In this test, 4-bit CQI Table 2 in Table 7.2.3-2 in TS 36.213 [6], and Modulation and TBS index table 2 in Table 7.1.7.1-1A for PDSCH in TS 36.213 [6] are applied.

**Table 9.3.1.2.3-1 Sub-band test for FDD**

Parameter	Unit	Test 1	
Bandwidth	MHz	10 MHz	
Transmission mode		9	
Downlink power allocation	$\rho_A$	dB	0
	$\rho_B$	dB	0
	$P_c$	dB	0
	$\sigma$	dB	0
SNR (Note 3)	dB	16	17
$\hat{I}_{or}^{(j)}$	dB[mW/15kHz]	-82	-81
$N_{oc}^{(j)}$	dB[mW/15kHz]	-98	-98
Propagation channel		Clause B.2.4 with $\tau_d = 0.45$ $\mu_s, a = 1, f_D = 5$ Hz	
Antenna configuration		2x2	
Beamforming Model		As specified in Section B.4.3	
CRS reference signals		Antenna ports 0	
CSI reference signals		Antenna ports 15, 16	
CSI-RS periodicity and subframe offset $T_{CSI-RS} / \Delta_{CSI-RS}$		5 / 1	
CSI-RS reference signal configuration		4	
CodeBookSubsetRestriction bitmap		000001	
Reporting interval (Note 4)	ms	5	
CQI delay	ms	8	
Reporting mode		PUSCH 3-1	
Sub-band size	RB	6 (full size)	
Max number of HARQ transmissions		1	
Note 1:	If the UE reports in an available uplink reporting instance at subframe SF#n based on CQI estimation at a downlink subframe not later than SF#(n-4), this reported subband or wideband CQI cannot be applied at the eNB downlink before SF#(n+4)		
Note 2:	Reference measurement channel RC.8A FDD according to Table A.4-1 with one/two sided dynamic OCNG Pattern OP.1/2 FDD as described in Annex A.5.1.1/2.		
Note 3:	For each test, the minimum requirements shall be fulfilled for at least one of the two SNR(s) and the respective wanted signal input level.		
Note 4:	PDCCH DCI format 0 with a trigger for aperiodic CQI shall be transmitted in downlink SF#1 and #6 to allow aperiodic CQI/PMI/RI to be transmitted in uplink SF#0 and #5.		

**Table 9.3.1.2.3-2 Minimum requirement (FDD)**

	Test 1
$\alpha$ [%]	2
$\beta$ [%]	40
$\gamma$	1.1
UE Category	11-12
UE DL Category	$\geq 11$

**9.3.1.2.4 TDD (Modulation and TBS index Table 2 and 4-bit CQI Table 2 are used)**

For the parameters specified in Table 9.3.1.2.4-1, and using the downlink physical channels specified in Annex C.3.2, the minimum requirements are specified in Table 9.3.1.2.4-2 and by the following

- a) a sub-band differential CQI offset level of 0 shall be reported at least  $\alpha\%$  of the time but less than  $\beta\%$  for each sub-band;
- b) the ratio of the throughput obtained when transmitting on a randomly selected sub-band among the sub-bands with the highest differential CQI offset level the corresponding TBS and that obtained when transmitting the TBS indicated by the reported wideband CQI median on a randomly selected sub-band in set  $S$  shall be  $\geq \gamma$ ;
- c) when transmitting on a randomly selected sub-band among the sub-bands with the highest differential CQI offset level the corresponding TBS, the average BLER for the indicated transport formats shall be greater or equal to 0.05.

The requirements only apply for sub-bands of full size and the random scheduling across the sub-bands is done by selecting a new sub-band in each TTI for FDD, each available downlink transmission instance for TDD. Sub-bands of a size smaller than full size are excluded from the test.

In this test, 4-bit CQI Table 2 in Table 7.2.3-2 in TS 36.213 [6], and Modulation and TBS index table 2 in Table 7.1.7.1-1A for PDSCH in TS 36.213 [6] are applied.

**Table 9.3.1.2.4-1 Sub-band test for TDD**

Parameter	Unit	Test 1	
Bandwidth	MHz	20 MHz	
Transmission mode		9	
Uplink downlink configuration		2	
Special subframe configuration		4	
Downlink power allocation	$\rho_A$	dB	0
	$\rho_B$	dB	0
	$P_C$	dB	0
	$\sigma$	dB	0

SNR (Note 3)	dB	16	17
$\hat{I}_{or}^{(j)}$	dB[mW/15kHz]	-82	-81
$N_{oc}^{(j)}$	dB[mW/15kHz]	-98	-98
Propagation channel		Clause B.2.4 with $\tau_d = 0.45$ $\mu s, a = 1, f_D = 5$ Hz	
Antenna configuration		2x2	
Beamforming Model		As specified in Section B.4.3	
CRS reference signals		Antenna port 0	
CSI reference signals		Antenna port 15,16	
CSI-RS periodicity and subframe offset $T_{CSI-RS} / \Delta_{CSI-RS}$		5/3	
CSI-RS reference signal configuration		4	
CodeBookSubsetRestriction bitmap		000001	
Reporting interval (Note 4)	ms	5	
CQI delay	ms	10	
Reporting mode		PUSCH 3-1	
Sub-band size	RB	8 (full size)	
Max number of HARQ transmissions		1	
ACK/NACK feedback mode		Multiplexing	
Note 1:	If the UE reports in an available uplink reporting instance at subframe SF#n based on CQI estimation at a downlink subframe not later than SF#(n-4), this reported subband or wideband CQI cannot be applied at the eNB downlink before SF#(n+4)		
Note 2:	Reference measurement channel RC.8A TDD according to Table A.4-1 with one/two sided dynamic OCNG Pattern OP.1/2 TDD as described in Annex A.5.2.1/2.		
Note 3:	For each test, the minimum requirements shall be fulfilled for at least one of the two SNR(s) and the respective wanted signal input level.		
Note 4:	PDCCH DCI format 0 with a trigger for aperiodic CQI shall be transmitted in downlink SF#3 and #8 to allow aperiodic CQI/PMI/RI to be transmitted on uplink SF#2 and #7.		

Table 9.3.1.2.4-2 Minimum requirement (TDD)

	Test 1
$\alpha$ [%]	2
$\beta$ [%]	40
$\gamma$	1.1
UE Category	11-12
UE DL Category	$\geq 11$

## 9.3.1.2.5 Void

Table 9.3.1.2.5-1: Void

Table 9.3.1.2.5-2: Void

9.3.1.2.6 TDD (when *csi-SubframeSet-r12* is configured with one CSI process)

The following requirements apply to UE Category  $\geq 1$  which supports Rel-12 CSI subframe sets and TM10. For the parameters specified in Table 9.3.1.2.6-1, and using the downlink physical channels specified in Annex C.3.2, the minimum requirements are specified in Table 9.3.1.2.6-2 and by the following

- a sub-band differential CQI offset level of 0 shall be reported at least  $\alpha\%$  of the time but less than  $\beta\%$  for each sub-band for each CSI subframe set;
- the ratio of the throughput obtained when transmitting on a randomly selected sub-band among the sub-bands with the highest differential CQI offset level the corresponding TBS and that obtained when transmitting the

TBS indicated by the reported wideband CQI median on a randomly selected sub-band in set  $S$  shall be  $\geq \gamma$  for each CSI subframe set;

- c) when transmitting on a randomly selected sub-band among the sub-bands with the highest differential CQI offset level the corresponding TBS, the average BLER for the indicated transport formats shall be greater or equal to 0.01 for each CSI subframe set.
- d) The difference of the wide-band median CQI obtained by reports in CSI subframe sets  $C_{CSI,0}$  and the wide-band median CQI obtained by reports in CSI subframe sets  $C_{CSI,1}$  shall be larger than or equal to 3.

The requirements only apply for sub-bands of full size and the random scheduling across the sub-bands is done by selecting a new sub-band in each available downlink transmission instance. Sub-bands of a size smaller than full size are excluded from the test.

**Table 9.3.1.2.6-1: Sub-band test for TDD**

Parameter	Unit	Test	
Bandwidth	MHz	10	
Transmission mode		10	
Uplink downlink configuration		2	
Special subframe configuration		4	
CSI-MeasSubframeSet-r12		0001100000	
Downlink power allocation	$\rho_A$	dB	0
	$\rho_B$	dB	0
	$\rho_C$	dB	-3
	$\sigma$	dB	-3
SNR in CSI subframe set 0	dB	0	1
SNR in CSI subframe set 1	dB	10	11
$\hat{I}_{or}^{(j)}$	dB[mW/15kHz]	-98	-97
$N_{oc1}^{(j)}$ for CSI subframe set 0	dB[mW/15kHz]	-98	-98
$N_{oc2}^{(j)}$ for CSI subframe set 1	dB[mW/15kHz]	-108	-108
Propagation channel		Clause B.2.4 with $\tau_d = 0.45$ $\mu s, a = 1, f_D = 5$ Hz	
Antenna configuration		2x2	
Beamforming Model		As specified in Section B.4.3	
CRS reference signals		Antenna port 0 and 1	
CSI reference signals		Antenna port 15,16	
CSI-RS periodicity and subframe offset $T_{CSI-RS} / \Delta_{CSI-RS}$		5/0	
CSI-RS reference signal configuration		0	
Zero-Power CSI-RS configuration 0 $l_{CSI-RS} / ZeroPowerCSI-RS$ bitmap		3 / 0000010000000000	
Zero-Power CSI-RS configuration 1 $l_{CSI-RS} / ZeroPowerCSI-RS$ bitmap		4 / 0100000000000000	
CSI-IM configuration 0 $l_{CSI-RS} / ZeroPowerCSI-RS$ bitmap		3 / 0000010000000000	
CSI-IM configuration 1 $l_{CSI-RS} / ZeroPowerCSI-RS$ bitmap		4 / 0100000000000000	
CSI process configuration Signal/Interference/Reporting mode for CSI subframe set 0		CSI-RS/CSI-IM 0/PUSCH 3-1	
CSI process configuration Signal/Interference/Reporting mode for CSI subframe set 1		CSI-RS/CSI-IM 1/PUSCH 3-1	
CodeBookSubsetRestriction bitmap		000001	
Reporting interval (Note 4)	ms	10 per subframe set	
CQI delay	ms	15 for CSI subframe set 0 15 for CSI subframe set 1	
Sub-band size	RB	6 (full size)	
PDSCH scheduled subframes for CSI subframe set 0		8,9	
PDSCH scheduled subframes for CSI subframe set 1		3,4	
Max number of HARQ transmissions		1	
ACK/NACK feedback mode		Multiplexing	
Note 1:	If the UE reports in an available uplink reporting instance at subframe SF#n based on CQI estimation at a downlink subframe not later than SF#(n-4), this reported subband or wideband CQI cannot be applied at the eNB downlink before SF#(n+4)		
Note 2:	Reference measurement channel RC.18 TDD according to Table A.4-1 with one/two sided dynamic OCNG Pattern OP.1/2 TDD as described in Annex A.5.2.1/2.		
Note 3:	For each test, the minimum requirements shall be fulfilled for at least one of the two SNR(s) and the respective wanted signal input level for each subframe set separately.		
Note 4:	For CSI subframe set 0, PDCCH DCI format 0 with a trigger for aperiodic CQI shall be transmitted in downlink SF#3 to allow aperiodic CQI/PMI/RI to be transmitted on uplink SF #7. For CSI subframe set 1, PDCCH DCI format 0 with a trigger for aperiodic CQI shall be transmitted in downlink SF#8 to allow aperiodic CQI/PMI/RI to be transmitted on uplink SF#2.		

**Table 9.3.1.2.6-2: Minimum requirement (TDD)**

	Test
$\alpha$ [%]	2
$\beta$ [%]	55
$\gamma$	1.02
UE Category	$\geq 1$

### 9.3.2 Frequency non-selective scheduling mode

The reporting accuracy of the channel quality indicator (CQI) under frequency non-selective fading conditions is determined by the reporting variance, and the relative increase of the throughput obtained when the transport format transmitted is that indicated by the reported CQI compared to the case for which a fixed transport format configured according to the reported median CQI is transmitted. In addition, the reporting accuracy is determined by a minimum BLER using the transport formats indicated by the reported CQI. The purpose is to verify that the UE is tracking the channel variations and selecting the largest transport format possible according to the prevailing channel state for frequently non-selective scheduling. To account for sensitivity of the input SNR the CQI reporting under frequency non-selective fading conditions is considered to be verified if the reporting accuracy is met for at least one of two SNR levels separated by an offset of 1 dB.

#### 9.3.2.1 Minimum requirement PUCCH 1-0 (Cell-Specific Reference Symbol)

##### 9.3.2.1.1 FDD

For the parameters specified in Table 9.3.2.1.1-1 and Table 9.3.2.1.1-3, and using the downlink physical channels specified in Annex C.3.2, the minimum requirements are specified in Table 9.3.2.1.1-2 and Table 9.3.2.1.1-4 and by the following

- a) a CQI index not in the set {median CQI -1, median CQI, median CQI +1} shall be reported at least  $\alpha$  % of the time;
- b) the ratio of the throughput obtained when transmitting the transport format indicated by each reported wideband CQI index and that obtained when transmitting a fixed transport format configured according to the wideband CQI median shall be  $\geq \gamma$ ;
- c) when transmitting the transport format indicated by each reported wideband CQI index, the average BLER for the indicated transport formats shall be greater or equal to 0.02

The applicability of the requirement with 5MHz bandwidth as specified in Table 9.3.2.1.1-3 and Table 9.3.2.1.1-4 is defined in 9.1.1.1.



Table 9.3.2.1.1-1 Fading test for single antenna (FDD)

Parameter	Unit	Test 1		Test 2	
Bandwidth	MHz	10 MHz			
Transmission mode		1 (port 0)			
Downlink power allocation	$\rho_A$	0			
	$\rho_B$	0			
	$\sigma$	0			
SNR (Note 3)	dB	6	7	12	13
$\hat{I}_{or}^{(j)}$	dB[mW/15kHz]	-92	-91	-86	-85
$N_{oc}^{(j)}$	dB[mW/15kHz]	-98		-98	
Propagation channel		EPA5			
Correlation and antenna configuration		High (1 x 2)			
Reporting mode		PUCCH 1-0			
Reporting periodicity	ms	$N_{pd} = 2$			
CQI delay	ms	8			
Physical channel for CQI reporting		PUSCH (Note 4)			
PUCCH Report Type		4			
<i>cqi-pmi-ConfigurationIndex</i>		1			
Max number of HARQ transmissions		1			
<p>Note 1: If the UE reports in an available uplink reporting instance at subframe SF#n based on CQI estimation at a downlink SF not later than SF#(n-4), this reported wideband CQI cannot be applied at the eNB downlink before SF#(n+4)</p> <p>Note 2: Reference measurement channel RC.1 FDD according to Table A.4-1 for Category 2-8 with one sided dynamic OCNG Pattern OP.1 FDD as described in Annex A.5.1.1 and RC.4 FDD according to Table A.4-1 for Category 1 with one/two sided dynamic OCNG Pattern OP.1/2 FDD as described in Annex A.5.1.1/2.</p> <p>Note 3: For each test, the minimum requirements shall be fulfilled for at least one of the two SNR(s) and the respective wanted signal input level.</p> <p>Note 4: To avoid collisions between CQI reports and HARQ-ACK it is necessary to report both on PUSCH instead of PUCCH. PDCCH DCI format 0 shall be transmitted in downlink SF#1, #3, #7 and #9 to allow periodic CQI to multiplex with the HARQ-ACK on PUSCH in uplink subframe SF#5, #7, #1 and #3.</p>					

Table 9.3.2.1.1-2 Minimum requirement (FDD)

	Test 1	Test 2
$\alpha$ [%]	20	20
$\gamma$	1.05	1.05
UE Category	$\geq 1$	$\geq 1$

Table 9.3.2.1.1-3 Fading test for single antenna (FDD)

Parameter	Unit	Test 1		Test 2	
Bandwidth	MHz	5 MHz			
Transmission mode		1 (port 0)			
Downlink power allocation	$\rho_A$	dB			
	$\rho_B$	dB			
	$\sigma$	dB			
SNR (Note 3)	dB	6	7	12	13
$\hat{I}_{or}^{(j)}$	dB[mW/15kHz]	-92	-91	-86	-85
$N_{oc}^{(j)}$	dB[mW/15kHz]	-98		-98	
Propagation channel		EPAS			
Correlation and antenna configuration		High (1 x 2)			
Reporting mode		PUCCH 1-0			
Reporting periodicity	ms	$N_{pd} = 2$			
CQI delay	ms	8			
Physical channel for CQI reporting		PUSCH (Note 4)			
PUCCH Report Type		4			
<i>cqi-pmi-ConfigurationIndex</i>		1			
Max number of HARQ transmissions		1			
<p>Note 1: If the UE reports in an available uplink reporting instance at subframe SF#n based on CQI estimation at a downlink SF not later than SF#(n-4), this reported wideband CQI cannot be applied at the eNB downlink before SF#(n+4)</p> <p>Note 2: Reference measurement channel RC.14 FDD according to Table A.4-1 for Category <math>\geq 2</math> with one sided dynamic OCNG Pattern OP.1 FDD as described in Annex A.5.1.1 and RC.15 FDD according to Table A.4-1 for Category 1 with one/two sided dynamic OCNG Pattern OP.1/2 FDD as described in Annex A.5.1.1/2. Note 3: For each test, the minimum requirements shall be fulfilled for at least one of the two SNR(s) and the respective wanted signal input level.</p> <p>Note 4: To avoid collisions between CQI reports and HARQ-ACK it is necessary to report both on PUSCH instead of PUCCH. PDCCH DCI format 0 shall be transmitted in downlink SF#1, #3, #7 and #9 to allow periodic CQI to multiplex with the HARQ-ACK on PUSCH in uplink subframe SF#5, #7, #1 and #3.</p>					

Table 9.3.2.1.1-4 Minimum requirement (FDD)

	Test 1	Test 2
$\alpha$ [%]	20	20
$\gamma$	1.05	1.05
UE Category	$\geq 1$	$\geq 1$

### 9.3.2.1.2 TDD

For the parameters specified in Table 9.3.2.1.2-1, and using the downlink physical channels specified in Annex C.3.2, the minimum requirements are specified in Table 9.3.2.1.2-2 and by the following

- a CQI index not in the set {median CQI -1, median CQI, median CQI +1} shall be reported at least  $\alpha$  % of the time;
- the ratio of the throughput obtained when transmitting the transport format indicated by each reported wideband CQI index and that obtained when transmitting a fixed transport format configured according to the wideband CQI median shall be  $\geq \gamma$ ;
- when transmitting the transport format indicated by each reported wideband CQI index, the average BLER for the indicated transport formats shall be greater or equal to 0.02.

Table 9.3.2.1.2-1 Fading test for single antenna (TDD)

Parameter	Unit	Test 1		Test 2	
Bandwidth	MHz	10 MHz			
Transmission mode		1 (port 0)			
Downlink power allocation	$\rho_A$	dB			
	$\rho_B$	dB			
	$\sigma$	dB			
Uplink downlink configuration		2			
Special subframe configuration		4			
SNR (Note 3)	dB	6	7	12	13
$\hat{I}_{or}^{(j)}$	dB[mW/15kHz]	-92	-91	-86	-85
$N_{oc}^{(j)}$	dB[mW/15kHz]	-98		-98	
Propagation channel		EPA5			
Correlation and antenna configuration		High (1 x 2)			
Reporting mode		PUCCH 1-0			
Reporting periodicity	ms	$N_{pd} = 5$			
CQI delay	ms	10 or 11			
Physical channel for CQI reporting		PUSCH (Note 4)			
PUCCH Report Type		4			
<i>cqi-pmi-ConfigurationIndex</i>		3			
Max number of HARQ transmissions		1			
ACK/NACK feedback mode		Multiplexing			
<p>Note 1: If the UE reports in an available uplink reporting instance at subframe SF#n based on CQI estimation at a downlink SF not later than SF#(n-4), this reported wideband CQI cannot be applied at the eNB downlink before SF#(n+4).</p> <p>Note 2: Reference measurement channel RC.1 TDD according to Table A.4-1 for Category 2-8 with one sided dynamic OCNG Pattern OP.1 TDD as described in Annex A.5.2.1 and RC.4 TDD according to Table A.4-1 for Category 1 with one/two sided dynamic OCNG Pattern OP.1/2 TDD as described in Annex A.5.2.1/2.</p> <p>Note 3: For each test, the minimum requirements shall be fulfilled for at least one of the two SNR(s) and the respective wanted signal input level.</p> <p>Note 4: To avoid collisions between CQI reports and HARQ-ACK it is necessary to report both on PUSCH instead of PUCCH. PDCCH DCI format 0 shall be transmitted in downlink SF#3 and #8 to allow periodic CQI to multiplex with the HARQ-ACK on PUSCH in uplink subframe SF#7 and #2.</p>					

Table 9.3.2.1.2-2 Minimum requirement (TDD)

	Test 1	Test 2
$\alpha$ [%]	20	20
$\gamma$	1.05	1.05
UE Category	$\geq 1$	$\geq 1$

## 9.3.2.2 Minimum requirement PUCCH 1-1 (CSI Reference Symbol)

## 9.3.2.2.1 FDD

For the parameters specified in Table 9.3.2.2.1-1, and using the downlink physical channels specified in Annex C.3.2, the minimum requirements are specified in Table 9.3.2.2.1-2 and by the following

- a CQI index not in the set {median CQI -1, median CQI, median CQI +1} shall be reported at least  $\alpha\%$  of the time;
- the ratio of the throughput obtained when transmitting the transport format indicated by each reported wideband CQI index and that obtained when transmitting a fixed transport format configured according to the wideband CQI median shall be  $\geq \gamma$ ;
- when transmitting the transport format indicated by each reported wideband CQI index, the average BLER for the indicated transport formats shall be greater or equal to 0.02.

Table 9.3.2.2.1-1 Fading test for FDD

Parameter	Unit	Test 1		Test 2	
Bandwidth	MHz	10 MHz			
Transmission mode		9			
Downlink power allocation	$\rho_A$	dB			
	$\rho_B$	dB			
	$\rho_C$	dB			
	$\sigma$	dB			
SNR (Note 3)	dB	2	3	7	8
$\hat{I}_{or}^{(j)}$	dB[mW/15kHz]	-96	-95	-91	-90
$N_{oc}^{(j)}$	dB[mW/15kHz]	-98		-98	
Propagation channel		EPA5			
Correlation and antenna configuration		ULA High (4 x 2)			
Beamforming Model		As specified in Section B.4.3			
Cell-specific reference signals		Antenna ports 0,1			
CSI reference signals		Antenna ports 15,...,18			
CSI-RS periodicity and subframe offset $T_{CSI-RS} / \Delta_{CSI-RS}$		5/1			
CSI-RS reference signal configuration		2			
CodeBookSubsetRestriction bitmap		0x0000 0000 0000 0001			
Reporting mode		PUCCH 1-1			
Reporting periodicity	ms	$N_{pd} = 5$			
CQI delay	ms	8			
Physical channel for CQI/ PMI reporting		PUSCH (Note 4)			
PUCCH Report Type for CQI/PMI		2			
PUCCH channel for RI reporting		PUCCH Format 2			
PUCCH report type for RI		3			
<i>cqi-pmi-ConfigurationIndex</i>		2			
<i>ri-ConfigIndex</i>		1			
Max number of HARQ transmissions		1			
Note 1:	If the UE reports in an available uplink reporting instance at subframe SF#n based on CQI estimation at a downlink SF not later than SF#(n-4), this reported wideband CQI cannot be applied at the eNB downlink before SF#(n+4)				
Note 2:	Reference measurement channel RC.7 FDD according to Table A.4-1 with one sided dynamic OCNG Pattern OP.1 FDD as described in Annex A.5.1.1.				
Note 3:	For each test, the minimum requirements shall be fulfilled for at least one of the two SNR(s) and the respective wanted signal input level.				
Note 4:	To avoid collisions between CQI/ PMI reports and HARQ-ACK it is necessary to report both on PUSCH instead of PUCCH. PDCCCH DCI format 0 shall be transmitted in downlink SF#1 and #6 to allow periodic CQI/ PMI to multiplex with the HARQ-ACK on PUSCH in uplink subframe SF#0 and #5.				

**Table 9.3.2.2.1-2 Minimum requirement (FDD)**

	<b>Test 1</b>	<b>Test 2</b>
$\alpha$ [%]	20	20
$\gamma$	1.05	1.05
UE Category	$\geq 2$	$\geq 2$

### 9.3.2.2.2 TDD

For the parameters specified in Table 9.3.2.2.2-1, and using the downlink physical channels specified in Annex C.3.2, the minimum requirements are specified in Table 9.3.2.2.2-2 and by the following

- a) a CQI index not in the set {median CQI -1, median CQI, median CQI +1} shall be reported at least  $\alpha\%$  of the time;
- b) the ratio of the throughput obtained when transmitting the transport format indicated by each reported wideband CQI index and that obtained when transmitting a fixed transport format configured according to the wideband CQI median shall be  $\geq \gamma$ ;
- c) when transmitting the transport format indicated by each reported wideband CQI index, the average BLER for the indicated transport formats shall be greater or equal to 0.02.

Table 9.3.2.2-1 Fading test for TDD

Parameter	Unit	Test 1		Test 2	
Bandwidth	MHz	10 MHz			
Transmission mode		9			
Uplink downlink configuration		2			
Special subframe configuration		4			
Downlink power allocation	$\rho_A$	dB	0		
	$\rho_B$	dB	0		
	$P_c$	dB	-6		
	$\sigma$	dB	-3		
SNR (Note 3)	dB	1	2	7	8
$\hat{I}_{or}^{(j)}$	dB[mW/15kHz]	-97	-96	-91	-90
$N_{oc}^{(j)}$	dB[mW/15kHz]	-98		-98	
Propagation channel		EPA5			
Correlation and antenna configuration		XP High (8 x 2)			
Beamforming Model		As specified in Section B.4.3			
CRS reference signals		Antenna ports 0, 1			
CSI reference signals		Antenna ports 15,...,22			
CSI-RS periodicity and subframe offset $T_{CSI-RS} / \Delta_{CSI-RS}$		5/ 3			
CSI-RS reference signal configuration		2			
CodeBookSubsetRestriction bitmap		0x0000 0000 0000 0020 0000 0000 0001			
Reporting mode		PUCCH 1-1 (Sub-mode: 2)			
Reporting periodicity	ms	$N_{pd} = 5$			
CQI delay	ms	10			
Physical channel for CQI/ PMI reporting		PUSCH (Note 4)			
PUCCH Report Type for CQI/ PMI		2c			
Physical channel for RI reporting		PUCCH Format 2			
PUCCH report type for RI		3			
<i>cqi-pmi-ConfigurationIndex</i>		3			
<i>ri-ConfigIndex</i>		805 (Note 5)			
Max number of HARQ transmissions		1			
ACK/NACK feedback mode		Multiplexing			
<p>Note 1: If the UE reports in an available uplink reporting instance at subframe SF#n based on CQI estimation at a downlink SF not later than SF#(n-4), this reported wideband CQI cannot be applied at the eNB downlink before SF#(n+4)</p> <p>Note 2: Reference measurement channel RC.7 TDD according to Table A.4-1 with one sided dynamic OCNG Pattern OP.1 TDD as described in Annex A.5.2.1.</p> <p>Note 3: For each test, the minimum requirements shall be fulfilled for at least one of the two SNR(s) and the respective wanted signal input level.</p> <p>Note 4: To avoid collisions between CQI/ PMI reports and HARQ-ACK it is necessary to report both on PUSCH instead of PUCCH. PDCCH DCI format 0 shall be transmitted in downlink SF#3 and #8 to allow periodic CQI/ PMI to multiplex with the HARQ-ACK on PUSCH in uplink subframe SF#2 and #7.</p> <p>Note 5: RI reporting interval is set to the maximum allowable length of 160ms to minimise collisions between RI, CQI/PMI and HARQ-ACK reports. In the case when all three reports collide, it is expected that CQI/PMI reports will be dropped, while RI and HARQ-ACK will be multiplexed. At eNB, CQI report collection shall be skipped every 160ms during performance verification and the reported CQI in subframe SF#7 of the previous frame is applied in downlink subframes until a new CQI (after CQI/PMI dropping) is available.</p>					

Table 9.3.2.2-2 Minimum requirement (TDD)

	Test 1	Test 2
$\alpha$ [%]	20	20
$\gamma$	1.05	1.05
UE Category	$\geq 2$	$\geq 2$

### 9.3.3 Frequency-selective interference

The accuracy of sub-band channel quality indicator (CQI) reporting under frequency selective interference conditions is determined by a percentile of the reported differential CQI offset level +2 for a preferred sub-band, and the relative increase of the throughput obtained when transmitting on a randomly selected sub-band among the sub-bands with the highest reported differential CQI offset level the corresponding transport format compared to the case for which a fixed format is transmitted on any sub-band in set  $S$  of TS 36.213 [6]. The purpose is to verify that preferred sub-bands are used for frequently-selective scheduling under frequency-selective interference conditions.

#### 9.3.3.1 Minimum requirement PUSCH 3-0 (Cell-Specific Reference Symbol)

##### 9.3.3.1.1 FDD

For the parameters specified in Table 9.3.3.1.1-1, and using the downlink physical channels specified in Annex C.3.2, the minimum requirements are specified in Table 9.3.3.1.1-2 and by the following

- a) a sub-band differential CQI offset level of +2 shall be reported at least  $\alpha\%$  for at least one of the sub-bands of full size at the channel edges;
- b) the ratio of the throughput obtained when transmitting on a randomly selected sub-band among the sub-bands with the highest differential CQI offset level the corresponding TBS and that obtained when transmitting the TBS indicated by the reported wideband CQI median on a randomly selected sub-band in set  $S$  shall be  $\geq \gamma$ ;

The requirements only apply for sub-bands of full size and the random scheduling across the sub-bands is done by selecting a new sub-band in each TTI for FDD, each available downlink transmission instance for TDD. Sub-bands of a size smaller than full size are excluded from the test.

**Table 9.3.3.1.1-1 Sub-band test for single antenna transmission (FDD)**

Parameter	Unit	Test 1	Test 2
Bandwidth	MHz	10 MHz	10 MHz
Transmission mode		1 (port 0)	1 (port 0)
Downlink power allocation	$\rho_A$	dB	0
	$\rho_B$	dB	0
	$\sigma$	dB	0
$I_{ot}^{(j)}$ for RB 0...5	dB[mW/15kHz]	-102	-93
$I_{ot}^{(j)}$ for RB 6...41	dB[mW/15kHz]	-93	-93
$I_{ot}^{(j)}$ for RB 42...49	dB[mW/15kHz]	-93	-102
$\hat{I}_{or}^{(j)}$	dB[mW/15kHz]	-94	-94
Max number of HARQ transmissions		1	
Propagation channel		Clause B.2.4 with $\tau_d = 0.45$ $\mu S, a = 1, f_D = 5$ Hz	
Reporting interval	ms	5	
Antenna configuration		1 x 2	
CQI delay	ms	8	
Reporting mode		PUSCH 3-0	
Sub-band size	RB	6 (full size)	
Note 1:	If the UE reports in an available uplink reporting instance at subframe SF#n based on CQI estimation at a downlink subframe not later than SF#(n-4), this reported subband or wideband CQI cannot be applied at the eNB downlink before SF#(n+4)		
Note 2:	Reference measurement channel RC.3 FDD according to Table A.4-1 with one/two sided dynamic OCNG Pattern OP.1/2 FDD as described in Annex A.5.1.1/2.		

**Table 9.3.3.1.1-2 Minimum requirement (FDD)**

	Test 1	Test 2
$\alpha$ [%]	60	60
$\gamma$	1.6	1.6
UE Category	$\geq 1$	$\geq 1$

### 9.3.3.1.2 TDD

For the parameters specified in Table 9.3.3.1.2-1, and using the downlink physical channels specified in Annex C.3.2, the minimum requirements are specified in Table 9.3.3.1.2-2 and by the following

- a) a sub-band differential CQI offset level of +2 shall be reported at least  $\alpha$ % for at least one of the sub-bands of full size at the channel edges;
- b) the ratio of the throughput obtained when transmitting on a randomly selected sub-band among the sub-bands with the highest differential CQI offset level the corresponding TBS and that obtained when transmitting the TBS indicated by the reported wideband CQI median on a randomly selected sub-band in set  $S$  shall be  $\geq \gamma$ ;

The requirements only apply for sub-bands of full size and the random scheduling across the sub-bands is done by selecting a new sub-band in each TTI for FDD, each available downlink transmission instance for TDD. Sub-bands of a size smaller than full size are excluded from the test.

**Table 9.3.3.1.2-1 Sub-band test for single antenna transmission (TDD)**

Parameter	Unit	Test 1	Test 2	
Bandwidth	MHz	10 MHz	10 MHz	
Transmission mode		1 (port 0)	1 (port 0)	
Downlink power allocation	$\rho_A$	dB	0	0
	$\rho_B$	dB	0	0
	$\sigma$	dB	0	0
Uplink downlink configuration		2		
Special subframe configuration		4		
$I_{ot}^{(j)}$ for RB 0...5	dB[mW/15kHz]	-102	-93	
$I_{ot}^{(j)}$ for RB 6...41	dB[mW/15kHz]	-93	-93	
$I_{ot}^{(j)}$ for RB 42...49	dB[mW/15kHz]	-93	-102	
$\hat{I}_{ot}^{(j)}$	dB[mW/15kHz]	-94	-94	
Max number of HARQ transmissions		1		
Propagation channel		Clause B.2.4 with $\tau_d = 0.45$ $\mu s, a = 1, f_D = 5$ Hz		
Antenna configuration		1 x 2		
Reporting interval	ms	5		
CQI delay	ms	10 or 11		
Reporting mode		PUSCH 3-0		
Sub-band size	RB	6 (full size)		
ACK/NACK feedback mode		Multiplexing		
Note 1:	If the UE reports in an available uplink reporting instance at subframe SF#n based on CQI estimation at a downlink subframe not later than SF#(n-4), this reported subband or wideband CQI cannot be applied at the eNB downlink before SF#(n+4).			
Note 2:	Reference measurement channel RC.3 TDD according to table A.4-1 with one/two sided dynamic OCNG Pattern OP.1/2 TDD as described in Annex A.5.2.1/2.			



**Table 9.3.3.1.2-2 Minimum requirement (TDD)**

	Test 1	Test 2
$\alpha$ [%]	60	60
$\gamma$	1.6	1.6
UE Category	$\geq 1$	$\geq 1$

9.3.3.2 Void

9.3.3.2.1 Void

9.3.3.2.2 Void

### 9.3.4 UE-selected subband CQI

The accuracy of UE-selected subband channel quality indicator (CQI) reporting under frequency-selective fading conditions is determined by the relative increase of the throughput obtained when transmitting on the UE-selected subbands with the corresponding transport format compared to the case for which a fixed format is transmitted on any subband in set  $S$  of TS 36.213 [6]. The purpose is to verify that correct subbands are accurately reported for frequency-selective scheduling. To account for sensitivity of the input SNR the subband CQI reporting under frequency-selective fading conditions is considered to be verified if the reporting accuracy is met for at least one of two SNR levels separated by an offset of 1 dB.

#### 9.3.4.1 Minimum requirement PUSCH 2-0 (Cell-Specific Reference Symbols)

##### 9.3.4.1.1 FDD

For the parameters specified in Table 9.3.4.1.1-1, and using the downlink physical channels specified in Annex C.3.2, the minimum requirements are specified in Table 9.3.4.1.1-2 and by the following

- a) the ratio of the throughput obtained when transmitting on a randomly selected subband among the best  $M$  subbands reported by the UE the corresponding TBS and that obtained when transmitting the TBS indicated by the reported wideband CQI median on a randomly selected subband in set  $S$  shall be  $\geq \gamma$ ;

The requirements only apply for subbands of full size and the random scheduling across the subbands is done by selecting a new subband in each TTI for FDD. The transport block size TBS (wideband CQI median) is that resulting from the code rate which is closest to that indicated by the wideband CQI median and the  $N_{\text{PRB}}$  entry in Table 7.1.7.2.1-1 of TS 36.213 [6] that corresponds to the subband size.

**Table 9.3.4.1.1-1 Subband test for single antenna transmission (FDD)**

Parameter	Unit	Test 1		Test 2	
Bandwidth	MHz	10 MHz			
Transmission mode		1 (port 0)			
Downlink power allocation	$\rho_A$	0			
	$\rho_B$	0			
	$\sigma$	0			
SNR (Note 3)	dB	9	10	14	15
$\hat{I}_{or}^{(j)}$	dB[mW/15kHz]	-89	-88	-84	-83
$N_{oc}^{(j)}$	dB[mW/15kHz]	-98		-98	
Propagation channel		Clause B.2.4 with $\tau_d = 0,45 \mu\text{s}$ , $a = 1$ , $f_D = 5 \text{ Hz}$			
Reporting interval	ms	5			
CQI delay	ms	8			
Reporting mode		PUSCH 2-0			
Max number of HARQ transmissions		1			
Subband size ( $k$ )	RBs	3 (full size)			
Number of preferred subbands ( $M$ )		5			
Note 1:	If the UE reports in an available uplink reporting instance at subframe SF#n based on CQI estimation at a downlink subframe not later than SF#(n-4), this reported subband or wideband CQI cannot be applied at the eNB downlink before SF#(n+4)				
Note 2:	Reference measurement channel RC.5 FDD according to Table A.4-1 with one/two sided dynamic OCN Pattern OP.1/2 FDD as described in Annex A.5.1.1/2.				
Note 3:	For each test, the minimum requirements shall be fulfilled for at least one of the two SNR(s) and the respective wanted signal input level.				

**Table 9.3.4.1.1-2 Minimum requirement (FDD)**

	Test 1	Test 2
$\gamma$	1.2	1.2
UE Category	$\geq 1$	$\geq 1$

### 9.3.4.1.2 TDD

For the parameters specified in Table 9.3.4.1.2-1, and using the downlink physical channels specified in Annex C.3.2, the minimum requirements are specified in Table 9.3.4.1.2-2 and by the following

- a) the ratio of the throughput obtained when transmitting on a randomly selected subband among the best  $M$  subbands reported by the UE the corresponding TBS and that obtained when transmitting the TBS indicated by the reported wideband CQI median on a randomly selected subband in set  $S$  shall be  $\geq \gamma$ ;

The requirements only apply for subbands of full size and the random scheduling across the subbands is done by selecting a new subband in each available downlink transmission instance for TDD. The transport block size TBS (wideband CQI median) is that resulting from the code rate which is closest to that indicated by the wideband CQI median and the  $N_{PRB}$  entry in Table 7.1.7.2.1-1 of TS 36.213 [6] that corresponds to the subband size.

Table 9.3.4.1.2-1 Sub-band test for single antenna transmission (TDD)

Parameter	Unit	Test 1		Test 2	
Bandwidth	MHz	10 MHz			
Transmission mode		1 (port 0)			
Downlink power allocation	$\rho_A$	0			
	$\rho_B$	0			
	$\sigma$	0			
Uplink downlink configuration		2			
Special subframe configuration		4			
SNR (Note 3)	dB	9	10	14	15
$\hat{I}_{or}^{(j)}$	dB[mW/15kHz]	-89	-88	-84	-83
$N_{oc}^{(j)}$	dB[mW/15kHz]	-98		-98	
Propagation channel		Clause B.2.4 with $\tau_a = 0.45 \mu\text{s}$ , $a = 1$ , $f_D = 5 \text{ Hz}$			
Reporting interval	ms	5			
CQI delay	ms	10 or 11			
Reporting mode		PUSCH 2-0			
Max number of HARQ transmissions		1			
Subband size ( $k$ )	RBs	3 (full size)			
Number of preferred subbands ( $M$ )		5			
ACK/NACK feedback mode		Multiplexing			
Note 1:	If the UE reports in an available uplink reporting instance at subframe SF#n based on CQI estimation at a downlink subframe not later than SF#(n-4), this reported subband or wideband CQI cannot be applied at the eNB downlink before SF#(n+4)				
Note 2:	Reference measurement channel RC.5 TDD according to Table A.4-1 with one/two sided dynamic OCN Pattern OP.1/2 TDD as described in Annex A.5.2.1/2.				
Note 3:	For each test, the minimum requirements shall be fulfilled for at least one of the two SNR(s) and the respective wanted signal input level.				

Table 9.3.4.1.2-2 Minimum requirement (TDD)

	Test 1	Test 2
$\gamma$	1.2	1.2
UE Category	$\geq 1$	$\geq 1$

### 9.3.4.2 Minimum requirement PUCCH 2-0 (Cell-Specific Reference Symbols)

#### 9.3.4.2.1 FDD

For the parameters specified in Table 9.3.4.2.1-1, and using the downlink physical channels specified in Annex C.3.2, the minimum requirements are specified in Table 9.3.4.2.1-2 and by the following

- a) the ratio of the throughput obtained when transmitting on subbands reported by the UE the corresponding TBS and that obtained when transmitting the TBS indicated by the reported wideband CQI median on a randomly selected subband in set  $S$  shall be  $\geq \gamma$ ;

The requirements only apply for subbands of full size and the random scheduling across the subbands is done by selecting a new subband in each TTI for FDD. The transport block size TBS (wideband CQI median) is that resulting from the code rate which is closest to that indicated by the wideband CQI median and the  $N_{PRB}$  entry in Table 7.1.7.2.1-1 of TS 36.213 [6] that corresponds to the subband size.

Table 9.3.4.2.1-1 Subband test for single antenna transmission (FDD)

Parameter	Unit	Test 1		Test 2	
Bandwidth	MHz	10 MHz			
Transmission mode		1 (port 0)			
Downlink power allocation	$\rho_A$	dB			
	$\rho_B$	dB			
	$\sigma$	dB			
SNR (Note 3)	dB	8	9	13	14
$\hat{I}_{or}^{(j)}$	dB[mW/15kHz]	-90	-89	-85	-84
$N_{oc}^{(j)}$	dB[mW/15kHz]	-98		-98	
Propagation channel		Clause B.2.4 with $\tau_d = 0,45 \mu\text{s}$ , $a = 1$ , $f_D = 5 \text{ Hz}$			
Reporting periodicity	ms	$N_P = 2$			
CQI delay	ms	8			
Physical channel for CQI reporting		PUSCH (Note 4)			
PUCCH Report Type for wideband CQI		4			
PUCCH Report Type for subband CQI		1			
Max number of HARQ transmissions		1			
Subband size ( $k$ )	RBs	6 (full size)			
Number of bandwidth parts ( $J$ )		3			
$K$		1			
$cqi-pmi-ConfigIndex$		1			
<p>Note 1: If the UE reports in an available uplink reporting instance at subframe SF#n based on CQI estimation at a downlink subframe not later than SF#(n-4), this reported subband or wideband CQI cannot be applied at the eNB downlink before SF#(n+4)</p> <p>Note 2: Reference measurement channel RC.3 FDD according to Table A.4-1 with one/two sided dynamic OCNG Pattern OP.1/2 FDD as described in Annex A.5.1.1/2.</p> <p>Note 3: For each test, the minimum requirements shall be fulfilled for at least one of the two SNR(s) and the respective wanted signal input level.</p> <p>Note 4: To avoid collisions between CQI reports and HARQ-ACK it is necessary to report both on PUSCH instead of PUCCH. PDCCH DCI format 0 shall be transmitted in downlink SF#1, #3, #7 and #9 to allow periodic CQI to multiplex with the HARQ-ACK on PUSCH in uplink subframe SF#5, #7, #1 and #3.</p> <p>Note 5: CQI reports for the short subband (having 2RBs in the last bandwidth part) are to be disregarded and data scheduling according to the most recent subband CQI report for bandwidth part with <math>j=1</math>.</p> <p>Note 6: In the case where wideband CQI is reported, data is to be scheduled according to the most recently used subband CQI report.</p>					

Table 9.3.4.2.1-2 Minimum requirement (FDD)

	Test 1	Test 2
$\gamma$	1.15	1.15
UE Category	$\geq 1$	$\geq 1$

#### 9.3.4.2.2 TDD

For the parameters specified in Table 9.3.4.2.2-1, and using the downlink physical channels specified in Annex C.3.2, the minimum requirements are specified in Table 9.3.4.2.2-2 and by the following

- a) the ratio of the throughput obtained when transmitting on subbands reported by the UE the corresponding TBS and that obtained when transmitting the TBS indicated by the reported wideband CQI median on a randomly selected subband in set  $S$  shall be  $\geq \gamma$ ;

The requirements only apply for subbands of full size and the random scheduling across the subbands is done by selecting a new subband in each available downlink transmission instance for TDD. The transport block size TBS (wideband CQI median) is that resulting from the code rate which is closest to that indicated by the wideband CQI median and the  $N_{PRB}$  entry in Table 7.1.7.2.1-1 of TS 36.213 [6] that corresponds to the subband size.

Table 9.3.4.2.2-1 Sub-band test for single antenna transmission (TDD)

Parameter	Unit	Test 1		Test 2	
Bandwidth	MHz	10 MHz			
Transmission mode		1 (port 0)			
Downlink power allocation	$\rho_A$	0			
	$\rho_B$	0			
	$\sigma$	0			
Uplink downlink configuration		2			
Special subframe configuration		4			
SNR (Note 3)	dB	8	9	13	14
$\hat{I}_{or}^{(j)}$	dB[mW/15kHz]	-90	-89	-85	-84
$N_{oc}^{(j)}$	dB[mW/15kHz]	-98		-98	
Propagation channel		Clause B.2.4 with $\tau_a = 0.45 \mu\text{s}$ , $a = 1$ , $f_D = 5 \text{ Hz}$			
Reporting periodicity	ms	$N_p = 5$			
CQI delay	ms	10 or 11			
Physical channel for CQI reporting		PUSCH (Note 4)			
PUCCH Report Type for wideband CQI		4			
PUCCH Report Type for subband CQI		1			
Max number of HARQ transmissions		1			
Subband size ( $k$ )	RBs	6 (full size)			
Number of bandwidth parts ( $J$ )		3			
$K$		1			
$cqi-pmi-ConfigIndex$		3			
ACK/NACK feedback mode		Multiplexing			
Note 1:	If the UE reports in an available uplink reporting instance at subframe SF#n based on CQI estimation at a downlink subframe not later than SF#(n-4), this reported subband or wideband CQI cannot be applied at the eNB downlink before SF#(n+4).				
Note 2:	Reference measurement channel RC.3 TDD according to Table A.4-1 with one/two sided dynamic OCNG Pattern OP.1/2 TDD as described in Annex A.5.2.1/2.				
Note 3:	For each test, the minimum requirements shall be fulfilled for at least one of the two SNR(s) and the respective wanted signal input level.				
Note 4:	To avoid collisions between CQI reports and HARQ-ACK it is necessary to report both on PUSCH instead of PUCCH. PDCCH DCI format 0 shall be transmitted in downlink SF#3 and #8 to allow periodic CQI to multiplex with the HARQ-ACK on PUSCH in uplink subframe SF#7 and #2.				
Note 5:	CQI reports for the short subband (having 2RBs in the last bandwidth part) are to be disregarded and data scheduling according to the most recent subband CQI report for bandwidth part with $j=1$ .				
Note 6:	In the case where wideband CQI is reported, data is to be scheduled according to the most recently used subband CQI report.				

**Table 9.3.4.2.2-2 Minimum requirement (TDD)**

	Test 1	Test 2
$\gamma$	1.15	1.15
UE Category	$\geq 1$	$\geq 1$

### 9.3.5 Additional requirements for enhanced receiver Type A

The purpose of the test is to verify that the reporting of the channel quality is based on the receiver of the enhanced Type A. Performance requirements are specified in terms of the relative increase of the throughput obtained when the transport format is that indicated by the reported CQI subject to an interference model compared to the case with a white Gaussian noise model, and a requirement on the minimum BLER of the transmitted transport formats indicated by the reported CQI subject to an interference model.

#### 9.3.5.1 Minimum requirement PUCCH 1-0 (Cell-Specific Reference Symbol)

##### 9.3.5.1.1 FDD

For the parameters specified in Table 9.3.5.1.1-1, and using the downlink physical channels specified in Annex C, the minimum requirements are specified in Table 9.3.5.1.1-2 and by the following

- a) the ratio of the throughput obtained when transmitting the transport format indicated by each reported wideband CQI index subject to an interference source with specified DIP and that obtained when transmitting the transport format indicated by each reported wideband CQI index subject to a white Gaussian noise source shall be  $\geq \gamma$ ;
- b) when transmitting the transport format indicated by each reported wideband CQI index subject to an interference source with specified DIP, the average BLER for the indicated transport formats shall be greater than or equal to 2%.

Table 9.3.5.1.1-1 Fading test for single antenna (FDD)

Parameter	Unit	Cell 1	Cell 2
Bandwidth	MHz	10 MHz	
Transmission mode		1 (port 0)	
Cyclic Prefix		Normal	Normal
Cell ID		0	1
SINR (Note 8)	dB	-2	N/A
$N_{oc}^{(j)}$	dB[mW/15kHz]	-98	N/A
Propagation channel		EPA5	Static (Note 7)
Correlation and antenna configuration		Low (1 x 2)	(1 x 2)
DIP (Note 4)	dB	N/A	-0.41
Reference measurement channel		Note 2	R.2 FDD
Reporting mode		PUCCH 1-0	N/A
Reporting periodicity	ms	$N_{pd} = 2$	N/A
CQI delay	ms	8	N/A
Physical channel for CQI reporting		PUSCH (Note 3)	N/A
PUCCH Report Type		4	N/A
<i>cqi-pmi-ConfigurationIndex</i>		1	N/A
Max number of HARQ transmissions		1	N/A
<p>Note 1: If the UE reports in an available uplink reporting instance at subframe SF#n based on CQI estimation at a downlink SF not later than SF#(n-4), this reported wideband CQI cannot be applied at the eNB downlink before SF#(n+4)</p> <p>Note 2: Reference measurement channel RC.1 FDD according to Table A.4-1 for Category 2-8 with one sided dynamic OCNG Pattern OP.1 FDD as described in Annex A.5.1.1 and RC.4 FDD according to Table A.4-1 for Category 1 with one/two sided dynamic OCNG Pattern OP.1/2 FDD as described in Annex A.5.1.1/2.</p> <p>Note 3: To avoid collisions between CQI reports and HARQ-ACK it is necessary to report both on PUSCH instead of PUCCH. PDCCH DCI format 0 shall be transmitted in downlink SF#1, #3, #7 and #9 to allow periodic CQI to multiplex with the HARQ-ACK on PUSCH in uplink subframe SF#5, #7, #1 and #3.</p> <p>Note 4: The respective received power spectral density of each interfering cell relative to <math>N_{oc}^{(j)}</math> is defined by its associated DIP value as specified in clause B.5.1.</p> <p>Note 5: Two cells are considered in which Cell 1 is the serving cell and Cell 2 is the interfering cell. The number of the CRS ports in both cells is the same. Interfering cell is fully loaded.</p> <p>Note 6: Both cells are time-synchronous.</p> <p>Note 7: Static channel is used for the interference model. In case for white Gaussian noise model Cell 2 is not present.</p> <p>Note 8: SINR corresponds to <math>E_s/N_{oc}^{(j)}</math> of Cell 1 as defined in clause 8.1.1.</p>			

Table 9.3.5.1.1-2 Minimum requirement (FDD)

$\gamma$	1.8
UE Category	$\geq 1$

## 9.3.5.1.2 TDD

For the parameters specified in Table 9.3.5.1.2-1, and using the downlink physical channels specified in Annex C, the minimum requirements are specified in 9.3.5.1.2-2 and by the following

- a) the ratio of the throughput obtained when transmitting the transport format indicated by each reported wideband CQI index subject to an interference source with specified DIP and that obtained when transmitting the transport format indicated by each reported wideband CQI index subject to a white Gaussian noise source shall be  $\geq \gamma$ ;



- b) when transmitting the transport format indicated by each reported wideband CQI index subject to an interference source with specified DIP, the average BLER for the indicated transport formats shall be greater than or equal to 2%.

**Table 9.3.5.1.2-1 Fading test for single antenna (TDD)**

Parameter	Unit	Cell 1	Cell 2
Bandwidth	MHz	10 MHz	
Transmission mode		1 (port 0)	
Uplink downlink configuration		2	
Special subframe configuration		4	
Cyclic Prefix		Normal	Normal
Cell ID		0	1
SINR (Note 8)	dB	-2	N/A
$N_{oc}^{(j)}$	dB[mW/15kHz]	-98	-98
Propagation channel		EPA5	Static (Note 7)
Correlation and antenna configuration		Low (1 x 2)	(1 x 2)
DIP (Note 4)	dB	N/A	-0.41
Reference measurement channel		Note 2	R.2A TDD
Reporting mode		PUCCH 1-0	N/A
Reporting periodicity	ms	$N_{pd} = 5$	N/A
CQI delay	ms	10 or 11	N/A
Physical channel for CQI reporting		PUSCH (Note 3)	N/A
PUCCH Report Type		4	N/A
<i>cqi-pmi-ConfigurationIndex</i>		3	N/A
Max number of HARQ transmissions		1	N/A
ACK/NACK feedback mode		Multiplexing	N/A
Note 1:	If the UE reports in an available uplink reporting instance at subframe SF#n based on CQI estimation at a downlink SF not later than SF#(n-4), this reported wideband CQI cannot be applied at the eNB downlink before SF#(n+4)		
Note 2:	Reference measurement channel RC.1 TDD according to Table A.4-1 for Category 2-8 with one sided dynamic OCNG Pattern OP.1 TDD as described in Annex A.5.2.1 and RC.4 TDD according to Table A.4-1 for Category 1 with one/two sided dynamic OCNG Pattern OP.1/2 TDD as described in Annex A.5.2.1/2.		
Note 3:	To avoid collisions between CQI reports and HARQ-ACK it is necessary to report both on PUSCH instead of PUCCH. PDCCH DCI format 0 shall be transmitted in downlink SF#3 and #8 to allow periodic CQI to multiplex with the HARQ-ACK on PUSCH in uplink subframe SF#7 and #2.		
Note 4:	The respective received power spectral density of each interfering cell relative to $N_{oc}^{(j)}$ is defined by its associated DIP value as specified in clause B.5.1.		
Note 5:	Two cells are considered in which Cell 1 is the serving cell and Cell 2 is the interfering cell. The number of the CRS ports in both cells is the same. Interfering cell is fully loaded.		
Note 6:	Both cells are time-synchronous.		
Note 7:	Static channel is used for the interference model. In case for white Gaussian noise model Cell 2 is not present.		
Note 8:	SINR corresponds to $E_s/N_{oc}^{(j)}$ of Cell 1 as defined in clause 8.1.1.		

**Table 9.3.5.1.2-2 Minimum requirement (TDD)**

$\gamma$	1.8
UE Category	$\geq 1$

### 9.3.5.2 Minimum requirement PUCCH 1-1 (CSI Reference Symbol)

#### 9.3.5.2.1 FDD

For the parameters specified in Table 9.3.5.2.1-1, and using the downlink physical channels specified in Annex C, the minimum requirements are specified in Table 9.3.5.2.1-2 and by the following

- a) the ratio of the throughput obtained when transmitting the transport format indicated by each reported wideband CQI index subject to an interference source with specified DIP and that obtained when transmitting the transport format indicated by each reported wideband CQI index subject to a white Gaussian noise source shall be  $\geq \gamma$ ;
- b) when transmitting the transport format indicated by each reported wideband CQI index subject to an interference source with specified DIP, the average BLER for the indicated transport formats shall be greater than or equal to 2%.

**Table 9.3.5.2.1-1 Fading test for two antennas (FDD)**

Parameter	Unit	Cell 1	Cell 2
Bandwidth	MHz	10 MHz	
Transmission mode		9	
Cyclic Prefix		Normal	Normal
Cell ID		0	1
SINR (Note 8)	dB	-2	N/A
$N_{oc}^{(j)}$	dB[mW/15kHz]	-98	N/A
Propagation channel		EPA5	Static (Note 7)
Correlation and antenna configuration		Low (2 x 2)	(1 x 2)
Beamforming Model		As specified in Section B.4.3 (Note 10, 11)	N/A
DIP (Note 4)	dB	N/A	-0.41
Cell-specific reference signals		Antenna ports 0,1	Antenna port 0
CSI reference signals		Antenna ports 15,16	N/A
CSI-RS periodicity and subframe offset		5/1	N/A
CSI-RS reference signal configuration		2	N/A
Zero-power CSI-RS configuration $i_{CSI-RS}$ / ZeroPowerCSI-RS bitmap	Subframes / bitmap	N/A	1 / 001000000000 000
CodeBookSubsetRestriction bitmap		001111	N/A
Reference measurement channel		Note 2	R.2 FDD
Reporting mode		PUCCH 1-1	N/A
Reporting periodicity	ms	$N_{pd} = 5$	N/A
CQI delay	ms	8	N/A
Physical channel for CQI/PMI reporting		PUSCH (Note 3)	N/A
PUCCH Report Type for CQI/PMI		2	N/A
PUCCH channel for RI reporting		PUCCH Format 2	N/A
PUCCH Report Type for RI		3	N/A
$cqi-pmi$ - ConfigurationIndex		2	N/A
$ri$ -ConfigIndex		1	N/A
Max number of HARQ transmissions		1	N/A

Note 1:	If the UE reports in an available uplink reporting instance at subframe SF#n based on CQI estimation at a downlink SF not later than SF#(n-4), this reported wideband CQI cannot be applied at the eNB downlink before SF#(n+4)
Note 2:	Reference measurement channel RC.11 FDD according to Table A.4-1 with one sided dynamic OCNNG Pattern OP.1 FDD as described in Annex A.5.1.1.
Note 3:	To avoid collisions between CQI/ PMI reports and HARQ-ACK it is necessary to report both on PUSCH instead of PUCCH. PDCCH DCI format 0 shall be transmitted in downlink SF#1 and #6 to allow periodic CQI/ PMI to multiplex with the HARQ-ACK on PUSCH in uplink subframe SF#0 and #5.
Note 4:	The respective received power spectral density of each interfering cell relative to $N_{oc}$ is defined by its associated DIP value as specified in clause B.5.1.
Note 5:	Two cells are considered in which Cell 1 is the serving cell and Cell 2 is the interfering cell. Interfering cell is fully loaded.
Note 6:	Both cells are time-synchronous.
Note 7:	Static channel is used for the interference model. In case for white Gaussian noise model Cell 2 is not present.
Note 8:	SINR corresponds to $E_s/N_{oc}$ of Cell 1 as defined in clause 8.1.1.
Note 9:	N/A.
Note 10:	The precoder in clause B.4.3 follows UE recommended PMI.
Note 11:	If the UE reports in an available uplink reporting instance at subframe SF#n based on PMI estimation at a downlink SF not later than SF#(n-4), this reported PMI cannot be applied at the eNB downlink before SF#(n+4).

**Table 9.3.5.2.1-2 Minimum requirement (FDD)**

$\gamma$	1.8
UE Category	$\geq 2$

**9.3.5.2.2 TDD**

For the parameters specified in Table 9.3.5.2.2-1, and using the downlink physical channels specified in Annex C, the minimum requirements are specified in 9.3.5.2.2-2 and by the following

- the ratio of the throughput obtained when transmitting the transport format indicated by each reported wideband CQI index subject to an interference source with specified DIP and that obtained when transmitting the transport format indicated by each reported wideband CQI index subject to a white Gaussian noise source shall be  $\geq \gamma$ ;
- when transmitting the transport format indicated by each reported wideband CQI index subject to an interference source with specified DIP, the average BLER for the indicated transport formats shall be greater than or equal to 2%.

**Table 9.3.5.2.2-1 Fading test for single antenna (TDD)**

Parameter	Unit	Cell 1	Cell 2
Bandwidth	MHz	10 MHz	
Transmission mode		9	
Uplink downlink configuration		2	
Special subframe configuration		4	
Cyclic Prefix		Normal	Normal
Cell ID		0	1
SINR (Note 8)	dB	-2	N/A
$N_{oc}^{(j)}$	dB[mW/15kHz]	-98	-98
Propagation channel		EPA5	Static (Note 7)
Correlation and antenna configuration		Low (2 x 2)	(1 x 2)
Beamforming Model		As specified in Section B.4.3 (Note 11, 12)	N/A
DIP (Note 4)	dB	N/A	-0.41
Cell-specific reference signals		Antenna ports 0,1	Antenna port 0
CSI reference signals		Antenna ports 15,16	N/A
CSI-RS periodicity and subframe offset		5/3	N/A
CSI-RS reference signal configuration		2	N/A
Zero-power CSI-RS configuration $I_{CSI-RS}$ / ZeroPowerCSI-RS bitmap	Subframes / bitmap	N/A	3 / 001000000000 0000
CodeBookSubsetRestriction bitmap		001111	N/A
Reference measurement channel		Note 2	R.2A TDD
Reporting mode		PUCCH 1-1	N/A
Reporting periodicity	ms	$N_{pd} = 5$	N/A
CQI delay	ms	10	N/A
Physical channel for CQI/PMI reporting		PUSCH (Note 3)	N/A
PUCCH Report Type for CQI/PMI		2	N/A
Physical channel for RI reporting		PUCCH Format 2	N/A
PUCCH Report Type for RI		3	N/A
$cqi-pmi-ConfigurationIndex$		3	N/A
$ri-ConfigIndex$		805 (Note 9)	N/A
Max number of HARQ transmissions		1	N/A
ACK/NACK feedback mode		Multiplexing	N/A

Note 1:	If the UE reports in an available uplink reporting instance at subframe SF#n based on CQI estimation at a downlink SF not later than SF#(n-4), this reported wideband CQI cannot be applied at the eNB downlink before SF#(n+4)
Note 2:	Reference measurement channel RC.11 TDD according to Table A.4-1 with one sided dynamic OCNG Pattern OP.1 TDD as described in Annex A.5.2.1.
Note 3:	To avoid collisions between CQI/ PMI reports and HARQ-ACK it is necessary to report both on PUSCH instead of PUCCH. PDCCH DCI format 0 shall be transmitted in downlink SF#3 and #8 to allow periodic CQI/ PMI to multiplex with the HARQ-ACK on PUSCH in uplink subframe SF#2 and #7.
Note 4:	The respective received power spectral density of each interfering cell relative to $N_{oc}$ is defined by its associated DIP value as specified in clause B.5.1.
Note 5:	Two cells are considered in which Cell 1 is the serving cell and Cell 2 is the interfering cell. Interfering cell is fully loaded.
Note 6:	Both cells are time-synchronous.
Note 7:	Static channel is used for the interference model. In case for white Gaussian noise model Cell 2 is not present.
Note 8:	SINR corresponds to $E_s/N_{oc}$ of Cell 1 as defined in clause 8.1.1.
Note 9:	RI reporting interval is set to the maximum allowable length of 160ms to minimise collisions between RI, CQI/PMI and HARQ-ACK reports. In the case when all three reports collide, it is expected that CQI/PMI reports will be dropped, while RI and HARQ-ACK will be multiplexed. At eNB, CQI report collection shall be skipped every 160ms during performance verification and the reported CQI in subframe SF#7 of the previous frame is applied in downlink subframes until a new CQI (after CQI/PMI dropping) is available.
Note 10:	N/A.
Note 11:	The precoder in clause B.4.3 follows UE recommended PMI.
Note 12:	If the UE reports in an available uplink reporting instance at subframe SF#n based on PMI estimation at a downlink SF not later than SF#(n-4), this reported PMI cannot be applied at the eNB downlink before SF#(n+4).

**Table 9.3.5.2.2-2 Minimum requirement (TDD)**

$\gamma$	1.8
UE Category	$\geq 2$

### 9.3.6 Minimum requirement (With multiple CSI processes)

The purpose of the test is to verify the reporting accuracy of the CQI and the UE processing capability for multiple CSI processes. Each CSI process is associated with a CSI-RS resource and a CSI-IM resource as shown in Table 9.3.6-1. For UE supports one CSI process, CSI process 2 is configured and the corresponding requirements shall be fulfilled. For UE supports three CSI processes, CSI processes 0, 1 and 2 are configured and the corresponding requirements shall be fulfilled. For UE supports four CSI processes, CSI processes 0, 1, 2 and 3 are configured and the corresponding requirements shall be fulfilled.

**Table 9.3.6-1: Configuration of CSI processes**

	CSI process 0	CSI process 1	CSI process 2	CSI process 3
CSI-RS resource	CSI-RS signal 0	CSI-RS signal 1	CSI-RS signal 0	CSI-RS signal 1
CSI-IM resource	CSI-IM resource 0	CSI-IM resource 0	CSI-IM resource 1	CSI-IM resource 2



### 9.3.6.1 FDD

For the parameters specified in Table 9.3.6.1-1, and using the downlink physical channels specified in Annex C.3.2, the minimum requirements are specified in Table 9.3.6.1-2 and by the following

- a) a sub-band differential CQI offset level of 0 shall be reported at least  $\alpha\%$  of the time but less than  $\beta\%$  for each sub-band for CSI process 1, 2, or 3;
- b) a CQI index not in the set {median CQI -1, median CQI, median CQI +1} shall be reported at least  $\delta\%$  of the time for CSI process 0;
- c) the difference of the median CQIs of the reported wideband CQI for configured CSI processes shall be greater or equal to the values as in Table 9.3.6.1-3;
- d) the ratio of the throughput obtained when transmitting on a randomly selected sub-band among the sub-bands with the highest differential CQI offset level the corresponding TBS and that obtained when transmitting the TBS indicated by the reported wideband CQI median on a randomly selected sub-band in set  $S$  shall be  $\geq \gamma$ ;
- e) when transmitting on a randomly selected sub-band among the sub-bands with the highest differential CQI offset level the corresponding TBS, the average BLER for the indicated transport formats shall be greater or equal to 0.02.

The requirements only apply for sub-bands of full size and the random scheduling across the sub-bands is done by selecting a new sub-band in each TTI for FDD, each available downlink transmission instance for TDD. Sub-bands of a size smaller than full size are excluded from the test.

**Table 9.3.6.1-1: Fading test for FDD**

Parameter	Unit	Test 1				Test 2			
		TP1		TP2		TP1		TP2	
Bandwidth	MHz	10 MHz				10 MHz			
Transmission mode		10		10		10		10	
Downlink power allocation	$\rho_A$	0				0			
	$\rho_B$	0				0			
	$P_c$	-3		0		-3		0	
	$\sigma$	-3				-3			
SNR (Note 7)	dB	10	11	7	8	14	15	9	10
$\hat{I}_{or}^{(j)}$	dB[mW/15kHz]	-88	-87	-91	-90	-84	-85	-89	-88
$N_{oc}^{(j)}$	dB[mW/15kHz]	-98				-98			
Propagation channel		EPA 5 Low		Clause B.2.4.1 with $\tau_d = 0.45 \mu s$ , $a = 1$ , $f_D = 5$ Hz		EPA 5 Low		Clause B.2.4.1 with $\tau_d = 0.45 \mu s$ , $a = 1$ , $f_D = 5$ Hz	
Antenna configuration		4x2		2x2		4x2		2x2	
Beamforming Model		As specified in Section B.4.3				As specified in Section B.4.3			
Timing offset between TPs	us	0				0			
Frequency offset between TPs	Hz	0				0			
Cell-specific reference signals		Antenna ports 0,1				Antenna ports 0,1			
CSI-RS signal 0		Antenna ports 15, ..., 18		N/A		Antenna ports 15, ..., 18		N/A	
CSI-RS 0 periodicity and subframe offset $T_{CSI-RS} / \Delta_{CSI-RS}$		5/1		N/A		5/1		N/A	
CSI-RS 0 configuration		0		N/A		0		N/A	
CSI-RS signal 1		N/A		Antenna ports 15, 16		N/A		Antenna ports 15, 16	
CSI-RS 1 periodicity and subframe offset $T_{CSI-RS} / \Delta_{CSI-RS}$		N/A		5/1		N/A		5/1	
CSI-RS 1 configuration		N/A		5		N/A		5	
Zero-power CSI-RS 0 configuration $l_{CSI-RS} / ZeroPowerCSI-RS$ bitmap		N/A		1 / 1110000000000000		N/A		1 / 1110000000000000	
Zero-power CSI-RS 1 configuration $l_{CSI-RS} / ZeroPowerCSI-RS$ bitmap		1 / 0010011000000000		N/A		1 / 0010011000000000		N/A	
CSI-IM 0 periodicity and subframe offset $T_{CSI-RS} / \Delta_{CSI-RS}$		5/1		5/1		5/1		5/1	
CSI-IM 0 configuration		2		2		2		2	
CSI-IM 1 periodicity and subframe offset $T_{CSI-RS} / \Delta_{CSI-RS}$		5/1		N/A		5/1		N/A	
CSI-IM 1 configuration		6		N/A		6		N/A	
CSI-IM 2 periodicity and subframe offset $T_{CSI-RS} / \Delta_{CSI-RS}$		N/A		5/1		N/A		5/1	
CSI-IM 2 configuration		N/A		1		N/A		1	
CSI process 0	CSI-RS	CSI-RS 0				CSI-RS 0			
	CSI-IM	CSI-IM 0				CSI-IM 0			
	Reporting mode	PUCCH 1-1				PUCCH 1-1			
	CodeBookSubsetRestriction bitmap	0x0000 0000 0000 0001				0x0000 0000 0000 0001			
	Reporting periodicity	ms				$N_{pd} = 5$			
	CQI delay	ms				11			
	Physical channel for CQI/ PMI reporting	PUSCH (Note 6)				PUSCH (Note 6)			
	PUCCH Report Type for CQI/PMI	2				2			
PUCCH channel for RI reporting	PUCCH Format 2				PUCCH Format 2				

	PUCCH report type for RI		3	3
	<i>cqi-pmi-ConfigurationIndex</i>		4	4
	<i>ri-ConfigIndex</i>		2	2
CSI process 1	CSI-RS		CSI-RS 1	CSI-RS 1
	CSI-IM		CSI-IM 0	CSI-IM 0
	Reporting mode		PUSCH 3-1	PUSCH 3-1
	CodeBookSubsetRestriction bitmap		000001	000001
	Reporting interval (Note 10)	ms	5	5
	CQI delay	ms	11	11
	Sub-band size	RB	6 (full size)	6 (full size)
CSI process 2 (For UE configured single process)	CSI-RS		CSI-RS 0	CSI-RS 0
	CSI-IM		CSI-IM 1	CSI-IM 1
	Reporting mode		PUSCH 3-1	PUSCH 3-1
	CodeBookSubsetRestriction bitmap		0x0000 0000 0000 0001	0x0000 0000 0000 0001
	Reporting interval (Note 8)	ms	5	5
	CQI delay	ms	8	8
Sub-band size	RB	6 (full size) (Note 9)	6 (full size) (Note 9)	
CSI process 3	CSI-RS		CSI-RS 1	CSI-RS 1
	CSI-IM		CSI-IM 2	CSI-IM 2
	Reporting mode		PUSCH 3-1	PUSCH 3-1
	CodeBookSubsetRestriction bitmap		000001	000001
	Reporting interval (Note 10)	ms	5	5
	CQI delay	ms	11	11
	Sub-band size	RB	6 (full size)	6 (full size)
CSI process for PDSCH scheduling			CSI process 2	
Cell ID		0	6	0
Quasi-co-located CSI-RS		CSI-RS 0	CSI-RS 1	CSI-RS 0
Quasi-co-located CRS		Same Cell ID as Cell 1	Same Cell ID as Cell 2	Same Cell ID as Cell 1
PMI for subframe 2, 3, 4, 7, 8 and 9		0x0000 0000 0000 0001	100000	0x0000 0000 0000 0001
PMI for subframe 1 and 6		0x0000 0000 0001 0000	100000	0x0000 0000 0001 0000
Max number of HARQ transmissions		1	N/A	1
<p>Note 1: If the UE reports in an available uplink reporting instance at subframe SF#n based on CQI estimation at a downlink SF not later than SF#(n-4), this reported wideband CQI cannot be applied at the eNB downlink before SF#(n+4)</p> <p>Note 2: 3 symbols allocated to PDCCH</p> <p>Note 3: Reference measurement channel RC.12 FDD according to Table A.4-1. PDSCH transmission is scheduled on subframe 2, 3, 4, 7, 8 and 9 from TP1.</p> <p>Note 4: TM10 OCNG OP.8 FDD as specified in A.5.1.8 is transmitted on subframe 1 and 6 from TP1.</p> <p>Note 5: TM10 OCNG OP.8 FDD as specified in A.5.1.8 is transmitted on subframe 1, 2, 3, 4, 6, 7, 8 and 9 from TP2</p> <p>Note 6: To avoid collisions between CQI/PMI reports and HARQ-ACK it is necessary to report both on PUSCH instead of PUCCH. PDCCH DCI format 0 shall be transmitted in downlink SF#3 and #8 to allow periodic CQI/PMI to multiplex with the HARQ-ACK on PUSCH in uplink SF#2 and #7.</p> <p>Note 7: For each test, the minimum requirements shall be fulfilled for at least one of the two SNR(s) and the respective wanted signal input level.</p> <p>Note 8: PDCCH DCI format 0 with a trigger for aperiodic CQI shall be transmitted in downlink SF#1 and #6 to allow aperiodic CQI/PMI/RI to be transmitted in uplink SF#0 and #5.</p> <p>Note 9: For these sub-bands which are not selected for PDSCH transmission, TM10 OCNG should be transmitted.</p> <p>Note 10: PDCCH DCI format 0 with a trigger for aperiodic CQI shall be transmitted in downlink SF#2 and #7 to allow aperiodic CQI/PMI/RI to be transmitted in uplink SF#1 and #6.</p>				

Table 9.3.6.1-2: Minimum requirement (FDD)

	CSI process 0	CSI process 1	CSI process 2	CSI process 3
$\alpha$ [%]	N/A	2	2	2
$\beta$ [%]	N/A	40	40	40
$\delta$ [%]	10	N/A	N/A	N/A
$\gamma$	N/A	N/A	1.02	N/A
UE Category	$\geq 1$			

Table 9.3.6.1-3: Minimum median CQI difference between configured CSI processes (FDD)

	CSI process 1	CSI process 2	CSI process 3
CSI process 0	N/A	1	3
UE Category	$\geq 1$		

### 9.3.6.2 TDD

For the parameters specified in Table 9.3.6.2-1, and using the downlink physical channels specified in Annex C.3.2, the minimum requirements are specified in Table 9.3.6.2-2 and by the following

- a sub-band differential CQI offset level of 0 shall be reported at least  $\alpha\%$  of the time but less than  $\beta\%$  for each sub-band for CSI process 1, 2, or 3;
- a CQI index not in the set {median CQI -1, median CQI, median CQI +1} shall be reported at least  $\delta\%$  of the time for CSI process 0;
- the difference of the median CQIs of the reported wideband CQI for configured CSI processes shall be greater or equal to the values as in Table 9.3.6.2-3;
- the ratio of the throughput obtained when transmitting on a randomly selected sub-band among the sub-bands with the highest differential CQI offset level the corresponding TBS and that obtained when transmitting the TBS indicated by the reported wideband CQI median on a randomly selected sub-band in set  $S$  shall be  $\geq \gamma$ ;
- when transmitting on a randomly selected sub-band among the sub-bands with the highest differential CQI offset level the corresponding TBS, the average BLER for the indicated transport formats shall be greater or equal to 0.02.

The requirements only apply for sub-bands of full size and the random scheduling across the sub-bands is done by selecting a new sub-band in each TTI for FDD, each available downlink transmission instance for TDD. Sub-bands of a size smaller than full size are excluded from the test.

**Table 9.3.6.2-1: Fading test for TDD**

Parameter	Unit	Test 1				Test 2			
		TP1		TP2		TP1		TP2	
Bandwidth	MHz	10 MHz				10 MHz			
Transmission mode		10		10		10		10	
Uplink downlink configuration		2		2		2		2	
Special subframe configuration		4		4		4		4	
Downlink power allocation	$\rho_A$	dB				0			
	$\rho_B$	dB				0			
	$\rho_C$	-3		0		-3		0	
	$\sigma$	dB				-3			
SNR (Note 7)	dB	10	11	7	8	14	15	9	10
$\hat{I}_{or}^{(j)}$	dB[mW/15kHz]	-88	-87	-91	-90	-84	-85	-89	-88
$N_{oc}^{(j)}$	dB[mW/15kHz]	-98				-98			
Propagation channel		EPA 5 Low		Clause B.2.4.1 with $\tau_d = 0.45 \mu s$ , $a = 1$ , $f_D = 5$ Hz		EPA 5 Low		Clause B.2.4.1 with $\tau_d = 0.45 \mu s$ , $a = 1$ , $f_D = 5$ Hz	
Antenna configuration		4x2		2x2		4x2		2x2	
Beamforming Model		As specified in Section B.4.3				As specified in Section B.4.3			
Timing offset between TPs	us	0				0			
Frequency offset between TPs	Hz	0				0			
Cell-specific reference signals		Antenna ports 0,1				Antenna ports 0,1			
CSI-RS signal 0		Antenna ports 15, ..., 18		N/A		Antenna ports 15, ..., 18		N/A	
CSI-RS 0 periodicity and subframe offset $T_{CSI-RS} / \Delta_{CSI-RS}$		5/3		N/A		5/3		N/A	
CSI-RS 0 configuration		0		N/A		0		N/A	
CSI-RS signal 1		N/A		Antenna ports 15, 16		N/A		Antenna ports 15, 16	
CSI-RS 1 periodicity and subframe offset $T_{CSI-RS} / \Delta_{CSI-RS}$		N/A		5/3		N/A		5/3	
CSI-RS 1 configuration		N/A		5		N/A		5	
Zero-power CSI-RS 0 configuration $l_{CSI-RS} / \text{ZeroPowerCSI-RS}$ bitmap		N/A		3 / 11100000000000000000		N/A		3 / 11100000000000000000	
Zero-power CSI-RS 1 configuration $l_{CSI-RS} / \text{ZeroPowerCSI-RS}$ bitmap		3 / 00100110000000000000		N/A		3 / 00100110000000000000		N/A	
CSI-IM 0 periodicity and subframe offset $T_{CSI-IM} / \Delta_{CSI-IM}$		5/3		5/3		5/3		5/3	
CSI-IM 0 configuration		2		2		2		2	
CSI-IM 1 periodicity and subframe offset $T_{CSI-IM} / \Delta_{CSI-IM}$		5/3		N/A		5/3		N/A	
CSI-IM 1 configuration		6		N/A		6		N/A	
CSI-IM 2 periodicity and subframe offset $T_{CSI-IM} / \Delta_{CSI-IM}$		N/A		5/3		N/A		5/3	
CSI-IM 2 configuration		N/A		1		N/A		1	
CSI process 0	CSI-RS	CSI-RS 0				CSI-RS 0			
	CSI-IM	CSI-IM 0				CSI-IM 0			
	Reporting mode	PUCCH 1-1				PUCCH 1-1			
	CodeBookSubsetRestriction bitmap	0x0000 0000 0000 0001				0x0000 0000 0000 0001			
	Reporting periodicity	ms				$N_{pd} = 5$			
	CQI delay	ms				12			
	Physical channel for CQI/PMI reporting	PUSCH (Note 6)				PUSCH (Note 6)			
	PUCCH Report Type for CQI/PMI	2				2			

	PUCCH channel for RI reporting		PUCCH Format 2		PUCCH Format 2	
	PUCCH report type for RI		3		3	
	<i>cqi-pmi-ConfigurationIndex</i>		3		3	
	<i>ri-ConfigIndex</i>		805 (Note 10)		805 (Note 10)	
CSI process 1	CSI-RS		CSI-RS 1		CSI-RS 1	
	CSI-IM		CSI-IM 0		CSI-IM 0	
	Reporting mode		PUSCH 3-1		PUSCH 3-1	
	CodeBookSubsetRestriction bitmap		000001		000001	
	Reporting interval (Note 9)	ms	5		5	
	CQI delay	ms	12		12	
	Sub-band size	RB	6 (full size)		6 (full size)	
CSI process 2	CSI-RS		CSI-RS 0		CSI-RS 0	
	CSI-IM		CSI-IM 1		CSI-IM 1	
	Reporting mode		PUSCH 3-1		PUSCH 3-1	
	CodeBookSubsetRestriction bitmap		0x0000 0000 0000 0001		0x0000 0000 0000 0001	
	Reporting interval (Note 9)	ms	5		5	
	CQI delay	ms	12		12	
	Sub-band size	RB	6 (full size) (Note 8)		6 (full size) (Note 8)	
CSI process 3	CSI-RS		CSI-RS 1		CSI-RS 1	
	CSI-IM		CSI-IM 2		CSI-IM 2	
	Reporting mode		PUSCH 3-1		PUSCH 3-1	
	CodeBookSubsetRestriction bitmap		000001		000001	
	Reporting interval (Note 9)	ms	5		5	
	CQI delay	ms	12		12	
	Sub-band size	RB	6 (full size)		6 (full size)	
CSI process for PDSCH scheduling			CSI process 2		CSI process 2	
Cell ID			0	6	0	6
Quasi-co-located CSI-RS			CSI-RS 0	CSI-RS 1	CSI-RS 0	CSI-RS 1
Quasi-co-located CRS			Same Cell ID as Cell 1	Same Cell ID as Cell 2	Same Cell ID as Cell 1	Same Cell ID as Cell 2
PMI for subframe 4 and 9			0x0000 0000 0000 0001	100000	0x0000 0000 0000 0001	100000
PMI for subframe 3 and 8			0x0000 0000 0001 0000	100000	0x0000 0000 0001 0000	100000
Max number of HARQ transmissions			1	N/A	1	N/A
ACK/NACK feedback mode			Multiplexing	N/A	Multiplexing	N/A
<p>Note 1: If the UE reports in an available uplink reporting instance at subframe SF#n based on CQI estimation at a downlink SF not later than SF#(n-4), this reported wideband CQI cannot be applied at the eNB downlink before SF#(n+4)</p> <p>Note 2: 3 symbols allocated to PDCCH</p> <p>Note 3: Reference measurement channel RC.12 TDD according to Table A.4-1. PDSCH transmission is scheduled on subframe 4 and 9 from TP1.</p> <p>Note 4: TM10 OCNG OP.8 TDD is transmitted as specified in A.5.2.8 on subframe 3 and 8 from TP1.</p> <p>Note 5: TM10 OCNG OP.8 TDD is transmitted as specified in A.5.2.8 on subframe 3, 4, 8 and 9 from TP2</p> <p>Note 6: To avoid collisions between CQI/PMI reports and HARQ-ACK it is necessary to report both on PUSCH instead of PUCCH. PDCCH DCI format 0 shall be transmitted in downlink SF#3 and #8 to allow periodic CQI/PMI to multiplex with the HARQ-ACK on PUSCH in uplink SF#7 and #2.</p> <p>Note 7: For each test, the minimum requirements shall be fulfilled for at least one of the two SNR(s) and the respective wanted signal input level.</p> <p>Note 8: PDCCH DCI format 0 with a trigger for aperiodic CQI shall be transmitted in downlink SF#3 and #8 to allow aperiodic CQI/PMI/RI to be transmitted in uplink SF#7 and #2.</p> <p>Note 9: For these sub-bands which are not selected for PDSCH transmission, TM10 OCNG should be transmitted.</p> <p>Note 10: RI reporting interval is set to the maximum allowable length of 160ms to minimise collisions between RI, CQI/PMI and HARQ-ACK reports. In the case when all three reports collide, it is expected that CQI/PMI reports will be dropped, while RI and HARQ-ACK will be multiplexed. At eNB, CQI report collection shall be skipped every 160ms during performance verification and the reported CQI in subframe SF#7 of the previous frame is applied in downlink subframes until a new CQI (after CQI/PMI dropping) is available.</p>						



Table 9.3.6.2-2: Minimum requirement (TDD)

	CSI process 0	CSI process 1	CSI process 2	CSI process 3
$\alpha$ [%]	N/A	2	2	2
$\beta$ [%]	N/A	40	40	40
$\delta$ [%]	10	N/A	N/A	N/A
$\gamma$	N/A	N/A	1.02	N/A
UE Category	$\geq 1$			

Table 9.3.6.2-3: Minimum median CQI difference between configured CSI processes (TDD)

	CSI process 1	CSI process 2	CSI process 3
CSI process 0	N/A	1	3
UE Category	$\geq 1$		

## 9.3.7 Minimum requirement PUSCH 3-2

### 9.3.7.1 FDD

For the parameters specified in Table 9.3.7.1-1, and using the downlink physical channels specified in Annex C.3.2, the minimum requirements are specified in Table 9.3.7.1-2 and by the following.

- a) the ratio of the throughput obtained when transmitting based on UE PUSCH 3-2 reported wideband CQI and subband PMI and that obtained when transmitting based on PUSCH 3-1 reported wideband CQI and wideband PMI shall be  $\geq \alpha$ ;
- b) The ratio of the throughput obtained when transmitting on a randomly selected sub-band among the sub-bands with the highest differential CQI offset level the corresponding TBS based on UE PUSCH3-2 reported subband CQI and subband PMI and that obtained when transmitting on a randomly selected sub-band in set S based on PUSCH 1-2 reported wideband CQI and subband PMI shall be  $\geq \beta$ ;

The transport block sizes TBS for wideband CQI and subband CQI are selected according to RC.17 FDD for test 1 and according to RC.18 FDD for test 2.

Table 9.3.7.1-1 Sub-band test for FDD

Parameter	Unit	Test 1		Test 2	
Bandwidth	MHz	10MHz			
PDSCH resource allocation	RB	50PRB		a subband, 6PRB	
Transmission mode		TM6		TM9	
Downlink power allocation	$\rho_A$	dB	-6	0	
	$\rho_B$	dB	-6	0	
	$P_c$	dB	-	-3	
	$\sigma$	dB	3	-3	
SNR (Note 3)	dB	0	1	5	6
$\hat{I}_{or}^{(j)}$	dB[mW/15kHz]	-98	-97	-93	-92
$N_{oc}^{(j)}$	dB[mW/15kHz]	-98	-98	-98	-98
Propagation channel		EVA5		EVA5	
Antenna configuration		4x2 ULA low		4x2 XP high (Note 4)	
Beamforming Model		-		B.4.3	
CRS reference signals		Antenna ports 0, 1, 2, 3		Antenna ports 0, 1	
Time offset between TX antenna (Note 5)	ns	65		-	
CSI reference signals		-		Antenna ports 15, 16, 17, 18	
CSI-RS periodicity and subframe offset $T_{CSI-RS} / \Delta_{CSI-RS}$		-		5/ 1	
CSI-RS reference signal configuration alternativeCodebookEnabledFor4TX		-		4	
CodeBookSubsetRestriction bitmap		No		Yes	
CodeBookSubsetRestriction bitmap		0x0000 0000 0000 FFFF		0x0000 0000 0000 FFFF 0000 FFFF	
Reporting interval (Note 6)	ms	5		5	
CQI delay	ms	8		8	
Reporting mode		PUSCH 3-2, PUSCH 3-1		PUSCH 3-2, PUSCH 1-2	
Sub-band size	RB	6 (full size)		6 (full size)	
Max number of HARQ transmissions		1		1	
Note 1:	If the UE reports in an available uplink reporting instance at subframe SF#n based on CQI estimation at a downlink subframe not later than SF#(n-4), this reported subband or wideband CQI cannot be applied at the eNB downlink before SF#(n+4)				
Note 2:	Reference measurement channel RC.17 FDD / RC.18 FDD for Test 1 / 2 according to Table A.4-1 with one/two sided dynamic OCNG Pattern OP.1/2 FDD as described in Annex A.5.1.1/2.				
Note 3:	For each test, the minimum requirements shall be fulfilled for at least one of the two SNR(s) and the respective wanted signal input level.				
Note 4:	Randomization of the principle beam direction shall be used as specified in B.2.3A.4.				
Note 5:	The values of time offset are [0ns 65ns 0ns 65ns] for antenna port [0, 1, 2, 3] respectively.				
Note 6:	PDCCH DCI format 0 with a trigger for aperiodic CQI shall be transmitted in downlink SF#1 and #6 to allow aperiodic CQI/PMI/RI to be transmitted in uplink SF#0 and #5.				

Table 9.3.7.1-2 Minimum requirement (FDD)

	Test 1	Test 2
$\alpha$	1.05	-
$\beta$	-	1.15
UE Category	$\geq 2$	$\geq 2$

### 9.3.7.2 TDD

For the parameters specified in Table 9.3.7.2-1, and using the downlink physical channels specified in Annex C.3.2, the minimum requirements are specified in Table 9.3.7.2-2 and by the following.

- a) the ratio of the throughput obtained when transmitting based on UE PUSCH 3-2 reported wideband CQI and subband PMI and that obtained when transmitting based on PUSCH 3-1 reported wideband CQI and wideband PMI shall be  $\geq \alpha$ ;

- b) The ratio of the throughput obtained when transmitting on a randomly selected sub-band among the sub-bands with the highest differential CQI offset level the corresponding TBS based on UE PUSCH3-2 reported subband CQI and subband PMI and that obtained when transmitting on a randomly selected sub-band in set S based on PUSCH 1-2 reported wideband CQI and subband PMI shall be  $\geq \beta$ ;

The transport block sizes TBS for wideband CQI and subband CQI are selected according to RC.17 TDD for test 1 and RC.18 TDD for test 2.

**Table 9.3.7.2-1 Sub-band test for TDD**

Parameter	Unit	Test 1		Test 2	
Bandwidth	MHz	10MHz			
PD SCH resource allocation	RB	50PRB		a subband, 6PRB	
Transmission mode		TM6		TM9	
Uplink downlink configuration		1		1	
Special subframe configuration		4		4	
Downlink power allocation	$\rho_A$	dB	-6	0	
	$\rho_B$	dB	-6	0	
	$P_c$	dB	-	-3	
	$\sigma$	dB	3	-3	
SNR (Note 3)	dB	0	1	5	6
$\hat{I}_{or}^{(j)}$	dB[mW/15kHz]	-98	-97	-93	-92
$N_{oc}^{(j)}$	dB[mW/15kHz]	-98	-98	-98	-98
Propagation channel		EVA5		EVA5	
Antenna configuration		4x2 ULA low		4x2 XP high (Note 4)	
Beamforming Model		-		B.4.3	
CRS reference signals		Antenna ports 0, 1, 2, 3		Antenna ports 0, 1	
Time offset between TX antenna (Note 5)	ns	65		-	
CSI reference signals				Antenna ports 15, 16, 17, 18	
CSI-RS periodicity and subframe offset $T_{CSI-RS} / \Delta_{CSI-RS}$		-		5/4	
CSI-RS reference signal configuration		-		4	
alternativeCodebookEnabledFor4TX		No		Yes	
CodeBookSubsetRestriction bitmap		0x0000 0000 0000 FFFF		0x0000 0000 0000 FFFF 0000 FFFF	
Reporting interval (Note 6)	ms	5		5	
CQI delay	ms	8		8	
Reporting mode		PUSCH 3-2, PUSCH 3-1		PUSCH 3-2, PUSCH 1-2	
Sub-band size	RB	6 (full size)		6 (full size)	
Max number of HARQ transmissions		1		1	
Note 1:	If the UE reports in an available uplink reporting instance at subframe SF#n based on CQI estimation at a downlink subframe not later than SF#(n-4), this reported subband or wideband CQI cannot be applied at the eNB downlink before SF#(n+4)				
Note 2:	Reference measurement channel RC.17 TDD / RC.18 TDD for Test 1 / 2 according to Table A.4-1 with one/two sided dynamic OCNG Pattern OP.1/2 TDD as described in Annex A.5.2.1/2.				
Note 3:	For each test, the minimum requirements shall be fulfilled for at least one of the two SNR(s) and the respective wanted signal input level.				
Note 4:	Randomization of the principle beam direction shall be used as specified in B.2.3A.4.				
Note 5:	The values of time offset are [0ns 65ns 0ns 65ns] for antenna port [0, 1, 2, 3] respectively.				
Note 6:	PDCCH DCI format 0 with a trigger for aperiodic CQI shall be transmitted in downlink SF#4 and #9 to allow aperiodic CQI/PMI/RI to be transmitted in uplink SF#3 and #8.				

**Table 9.3.7.2-2 Minimum requirement (TDD)**

	<b>Test 1</b>	<b>Test 2</b>
$\alpha$	1.05	-
$\beta$	-	1.15
UE Category	$\geq 2$	$\geq 2$

### 9.3.8 Additional requirements for enhanced receiver Type B

The purpose of the test is to verify that the reporting of the channel quality based on the receiver of the enhanced Type B meets a minimum performance. Performance requirements are specified in terms of the relative throughput obtained when the transport format is that indicated by the reported CQI with NeighCellsInfo-r12 configured compared to the case without NeighCellsInfo-r12 configured. Cell 1 is the serving cell, and Cell 2 and Cell 3 are the interference cells.

#### 9.3.8.1 Minimum requirement PUCCH 1-1 (Cell-Specific Reference Symbols)

##### 9.3.8.1.1 FDD

For the parameters specified in Table 9.3.8.1.1-1, and using the downlink physical channels specified in Annex C, the minimum requirements are specified in Table 9.3.8.1.1-2 and by the following

- a) the ratio of the throughput obtained when transmitting the transport format indicated by each reported wideband CQI index subject to interference sources with NeighCellsInfo-r12 configured and that obtained when transmitting the transport format indicated by each reported wideband CQI index subject to interference sources without NeighCellsInfo-r12 configured shall be  $\geq \gamma$ ;

Table 9.3.8.1.1-1 Fading test for FDD

Parameter		Unit	Cell 1	Cell 2	Cell 3
Bandwidth		MHz		10	
Transmission mode				4	
Downlink power allocation	$\rho_A$	dB		-3	
	$\rho_B$	dB		-3	
	$\sigma$	dB		0	
Cyclic Prefix			Normal	Normal	Normal
Cell ID			0	1	6
SNR		dB	8.34	N/A	N/A
$\bar{E}_i/N_{oc}$			N/A	3.28	0.74
$\hat{I}_{or}^{(j)}$		dB [mW/15kHz]	-89.66	-94.72	-97.26
$N_{oc}$		dB [mW/15kHz]	-98		
Propagation channel			EPA5	EPA5	EPA5
Correlation and antenna configuration			Low 2 x 2	Low 2 x 2	Low 2 x 2
Cell-specific reference signals			Antenna ports 0,1	Antenna ports 0,1	Antenna ports 0,1
Interference model			N/A	As specified in clause B.6.3	As specified in clause B.6.3
Reporting periodicity		ms	$N_{pd} = 5$	N/A	N/A
Physical channel for CQI/PMI reporting			PUCCH Format 2	N/A	N/A
PUCCH Report Type for CQI/PMI			2	N/A	N/A
PUCCH Report Type for RI			3	N/A	N/A
cqi-pmi-ConfigurationIndex			6	N/A	N/A
ri-ConfigurationIndex			1	N/A	N/A
CodeBookSubsetRestriction bitmap			000001	N/A	N/A
Max number of HARQ transmissions			1	N/A	N/A
NeighCellsInfo-r12 (Note 4)	p-aList-r12		N/A	{dB-6, dB-3, dB0}	{dB-6, dB-3, dB0}
	transmissionModeList-r12		N/A	{2,3,4,8,9}	{2,3,4,8,9}
Note 1: If the UE reports in an available uplink reporting instance at subframe SF#n based on CQI estimation at a downlink SF not later than SF#(n-4), this reported wideband CQI cannot be applied at the eNB downlink before SF#(n+4)					
Note 2: Reference measurement channel RC.2 FDD according to Table A.4-1 with one sided dynamic OCNB Pattern OP.1 FDD as described in Annex A.5.1.1.					
Note 3: All cells are time-synchronous.					
Note 4: NeighCellsInfo-r12 is described in subclause 6.3.2 of [7].					

Table 9.3.8.1.1-2 Minimum requirement (FDD)

	Test 1
$\gamma$	0.925
UE Category	$\geq 2$

## 9.3.8.1.2 TDD

For the parameters specified in Table 9.3.8.1.2-1, and using the downlink physical channels specified in Annex C, the minimum requirements are specified in 9.3.8.1.2-2 and by the following

- a) the ratio of the throughput obtained when transmitting the transport format indicated by each reported wideband CQI index subject to interference sources with NeighCellsInfo-r12 configured and that obtained when transmitting the transport format indicated by each reported wideband CQI index subject to interference sources without NeighCellsInfo-r12 configured shall be  $\geq \gamma$ ;

Table 9.3.8.1.2-1 Fading test for TDD

Parameter		Unit	Cell 1	Cell 2	Cell 3
Bandwidth		MHz		10	
Transmission mode				4	
Uplink downlink configuration				2	
Special subframe configuration				4	
Downlink power allocation	$\rho_A$	dB		-3	
	$\rho_B$	dB		-3	
	$\sigma$	dB		0	
Cyclic Prefix			Normal	Normal	Normal
Cell ID			0	1	6
SNR		dB	8.34	N/A	N/A
$\bar{E}_i/N_{oc}$			N/A	3.28	0.74
$\hat{I}_{or}^{(j)}$		dB [mW/15kHz]	-89.66	-94.72	-97.26
$N_{oc}$		dB [mW/15kHz]		-98	
Propagation channel			EPA5	EPA5	EPA5
Correlation and antenna configuration			Low 2 x 2	Low 2 x 2	Low 2 x 2
Cell-specific reference signals			Antenna ports 0,1	Antenna ports 0,1	Antenna ports 0,1
Interference model			N/A	As specified in clause B.6.3	As specified in clause B.6.3
Reporting periodicity		ms	$N_{pd} = 5$	N/A	N/A
Physical channel for CQI/PMI reporting			PUSCH (Note 3)	N/A	N/A
PUCCH Report Type			2	N/A	N/A
cqi-pmi-ConfigurationIndex			3	N/A	N/A
ri-ConfigIndex			805 (Note 5)	N/A	N/A
CodeBookSubsetRestriction bitmap			000001	N/A	N/A
Max number of HARQ transmissions			1	N/A	N/A
ACK/NACK feedback mode			Multiplexing	N/A	N/A
NeighCellsInfo-r12 (Note 6)	p-aList-r12		N/A	{dB-6, dB-3, dB0}	{dB-6, dB-3, dB0}
	transmissionModeList-r12		N/A	{2,3,4,8,9}	{2,3,4,8,9}
<p>Note 1: If the UE reports in an available uplink reporting instance at subframe SF#n based on CQI estimation at a downlink SF not later than SF#(n-4), this reported wideband CQI cannot be applied at the eNB downlink before SF#(n+4)</p> <p>Note 2: Reference measurement channel RC.2 TDD according to Table A.4-1 with one sided dynamic OCNG Pattern OP.1 TDD as described in Annex A.5.2.1.</p> <p>Note 3: To avoid collisions between CQI reports and HARQ-ACK it is necessary to report both on PUSCH instead of PUCCH. PDCCH DCI format 0 shall be transmitted in downlink SF#3 and #8 to allow periodic CQI to multiplex with the HARQ-ACK on PUSCH in uplink subframe SF#7 and #2.</p> <p>Note 4: All cells are time-synchronous.</p> <p>Note 5: RI reporting interval is set to the maximum allowable length of 160ms to minimise collisions between RI, CQI/PMI and HARQ-ACK reports. In the case when all three reports collide, it is expected that CQI/PMI reports will be dropped, while RI and HARQ-ACK will be multiplexed. At eNB, CQI report collection shall be skipped every 160ms during performance verification.</p> <p>Note 6: NeighCellsInfo-r12 is described in subclause 6.3.2 of [7].</p>					

Table 9.3.8.1.2-2 Minimum requirement (TDD)

	Test 1
$\gamma$	0.925
UE Category	$\geq 2$

## 9.3.8.2 Minimum requirement PUCCH 1-1 (CSI Reference Symbols)

### 9.3.8.2.1 FDD

For the parameters specified in Table 9.3.8.2.1-1, and using the downlink physical channels specified in Annex C, the minimum requirements are specified in Table 9.3.8.2.1-2 and by the following

- a) the ratio of the throughput obtained when transmitting the transport format indicated by each reported wideband CQI index subject to interference sources with NeighCellsInfo-r12 configured and that obtained when transmitting the transport format indicated by each reported wideband CQI index subject to interference sources without NeighCellsInfo-r12 configured shall be  $\geq \gamma$ ;

Table 9.3.8.2.1-1 Fading test for FDD

Parameter	Unit	Cell 1	Cell 2	Cell 3
Bandwidth	MHz		10	
Transmission mode			9	
Downlink power allocation	$\rho_A$	dB	0	
	$\rho_B$	dB	0	
	$P_c$	dB	0	
	$\sigma$	dB	0	
Cyclic Prefix		Normal	Normal	Normal
Cell ID		0	1	6
SNR	dB	8.34	N/A	N/A
$\bar{E}_s/N_{oc}$		N/A	3.28	0.74
$\hat{I}_{or}^{(j)}$	dB [mW/15kHz]	-89.66	-94.72	-97.26
$N_{oc}$	dB [mW/15kHz]		-98	
Propagation channel		EPA5	EPA5	EPA5
Correlation and antenna configuration		Low 2 x 2	Low 2 x 2	Low 2 x 2
Cell-specific reference signals		Antenna ports 0,1	Antenna ports 0,1	Antenna ports 0,1
Beamforming Model		As specified in Section B.4.3		
CSI reference signals		Antenna ports 15,16	N/A	N/A
CSI-RS periodicity and subframe offset		5/1	N/A	N/A
CSI-RS reference signal configuration		2	N/A	N/A
Zero-power CSI-RS configuration $l_{CSI-RS} / ZeroPowerCSI-RS$ bitmap	Subframes / bitmap	N/A	1 / 00010000000000 00	1 / 00010000000000 00
CodeBookSubsetRestriction bitmap		000001	N/A	N/A
Interference model		N/A	As specified in clause B.6.4	As specified in clause B.6.4
Reporting periodicity	ms	$N_{pd} = 5$	N/A	N/A
Physical channel for CQI/PMI reporting		PUSCH (Note 3)	N/A	N/A
PUCCH Report Type for CQI/PMI		2	N/A	N/A
PUCCH channel for RI reporting		PUCCH Format 2	N/A	N/A
PUCCH Report Type for RI		3	N/A	N/A
$cqi-pmi-ConfigurationIndex$		2	N/A	N/A
$ri-ConfigIndex$		1	N/A	N/A
Max number of HARQ transmissions		1	N/A	N/A
NeighCellsInfo- r12 (Note 5)	p-aList-r12 transmission ModeList-r12	N/A	{dB-6, dB-3, dB0}	{dB-6, dB-3, dB0}
		N/A	{2,3,4,8,9}	{2,3,4,8,9}
Note 1:	If the UE reports in an available uplink reporting instance at subframe SF#n based on CQI estimation at a downlink SF not later than SF#(n-4), this reported wideband CQI cannot be applied at the eNB downlink before SF#(n+4)			
Note 2:	Reference measurement channel RC.11 FDD according to Table A.4-1 with one sided dynamic OCNG Pattern OP.1 FDD as described in Annex A.5.1.1.			
Note 3:	To avoid collisions between CQI/PMI reports and HARQ-ACK it is necessary to report both on PUSCH instead of PUCCH. PDCCH DCI format 0 shall be transmitted in downlink SF#1 and #6 to allow periodic CQI/ PMI to multiplex with the HARQ-ACK on PUSCH in uplink subframe SF#0 and #5.			
Note 4:	All cells are time-synchronous.			
Note 5:	NeighCellsInfo-r12 is described in subclause 6.3.2 of [7].			



**Table 9.3.8.2.1-2 Minimum requirement (FDD)**

	Test 1
$\gamma$	0.925
UE Category	$\geq 2$

**9.3.8.2.2 TDD**

For the parameters specified in Table 9.3.8.2.2-1, and using the downlink physical channels specified in Annex C, the minimum requirements are specified in 9.3.8.2.2-2 and by the following

- a) the ratio of the throughput obtained when transmitting the transport format indicated by each reported wideband CQI index subject to interference sources with NeighCellsInfo-r12 configured and that obtained when transmitting the transport format indicated by each reported wideband CQI index subject to interference sources without NeighCellsInfo-r12 configured shall be  $\geq \gamma$ ;

**Table 9.3.8.2.2-1 Fading test for TDD**

Parameter	Unit	Cell 1	Cell 2	Cell 3
Bandwidth	MHz		10	
Transmission mode			9	
Downlink power allocation	$\rho_A$	dB	0	
	$\rho_B$	dB	0	
	$\rho_C$	dB	0	
	$\sigma$	dB	0	
Uplink downlink configuration			2	
Special subframe configuration			4	
Cyclic Prefix		Normal	Normal	Normal
Cell ID		0	1	6
SNR	dB	8.34	N/A	N/A
$\bar{E}_s/N_{oc}$		N/A	3.28	0.74
$\hat{I}_{or}^{(j)}$	dB [mW/15kHz]	-89.66	-94.72	-97.26
$N_{oc}$	dB [mW/15kHz]		-98	
Propagation channel		EPA5	EPA5	EPA5
Correlation and antenna configuration		Low 2 x 2	Low 2 x 2	Low 2 x 2
Cell-specific reference signals		Antenna ports 0,1	Antenna ports 0,1	Antenna ports 0,1
Beamforming Model		As specified in Section B.4.3		
CSI reference signals		Antenna ports 15,16	N/A	N/A
CSI-RS periodicity and subframe offset		5/3	N/A	N/A
CSI-RS reference signal configuration		2	N/A	N/A
Zero-power CSI-RS configuration $I_{CSI-RS} / \text{ZeroPowerCSI-RS}$ bitmap	Subframes / bitmap	N/A	3 / 000100000000 000	3 / 000100000000 000
CodeBookSubsetRestriction bitmap		000001	N/A	N/A
Interference model		N/A	As specified in clause B.6.4	As specified in clause B.6.4
Reporting periodicity	ms	$N_{pd} = 5$	N/A	N/A
Physical channel for CQI/PMI reporting		PUSCH (Note 3)	N/A	N/A
PUCCH Report Type for CQI/PMI		2	N/A	N/A
Physical channel for RI reporting		PUCCH Format 2	N/A	N/A
PUCCH Report Type for RI		3	N/A	N/A
$cqi-pmi-ConfigurationIndex$		3	N/A	N/A
$ri-ConfigIndex$		805 (Note 5)	N/A	N/A
Max number of HARQ transmissions		1	N/A	N/A
ACK/NACK feedback mode		Multiplexing	N/A	N/A
NeighCellsInfo- r12 (Note 6)	p-aList-r12	N/A	{dB-6, dB-3, dB0}	{dB-6, dB-3, dB0}
	transmission ModeList-r12	N/A	{2,3,4,8,9}	{2,3,4,8,9}

Note 1:	If the UE reports in an available uplink reporting instance at subframe SF#n based on CQI estimation at a downlink SF not later than SF#(n-4), this reported wideband CQI cannot be applied at the eNB downlink before SF#(n+4)
Note 2:	Reference measurement channel RC.11 TDD according to Table A.4-1 with one sided dynamic OCNG Pattern OP.1 TDD as described in Annex A.5.2.1.
Note 3:	To avoid collisions between CQI/PMI reports and HARQ-ACK it is necessary to report both on PUSCH instead of PUCCH. PDCCH DCI format 0 shall be transmitted in downlink SF#3 and #8 to allow periodic CQI/ PMI to multiplex with the HARQ-ACK on PUSCH in uplink subframe SF#2 and #7.
Note 4:	All cells are time-synchronous.
Note 5:	RI reporting interval is set to the maximum allowable length of 160ms to minimise collisions between RI, CQI/PMI and HARQ-ACK reports. In the case when all three reports collide, it is expected that CQI/PMI reports will be dropped, while RI and HARQ-ACK will be multiplexed. At eNB, CQI report collection shall be skipped every 160ms during performance verification and the reported CQI in subframe SF#7 of the previous frame is applied in downlink subframes until a new CQI (after CQI/PMI dropping) is available.
Note 6:	NeighCellsInfo-r12 is described in subclause 6.3.2 of [7].

**Table 9.3.8.2.2-2 Minimum requirement (TDD)**

	Test 1
$\gamma$	0.925
UE Category	$\geq 2$

### 9.3.8.3 Minimum requirement with CSI process

#### 9.3.8.3.1 FDD

For the parameters specified in Table 9.3.8.3.1-1, and using the downlink physical channels specified in Annex C, the minimum requirements are specified in Table 9.3.8.3.1-2 and by the following

- a) the ratio of the throughput obtained for the Type B receiver with NAICS assistance information when transmitting the transport format indicated by each reported wideband CQI index subject to interference sources with specified  $\hat{E}_s/N_{oc}$  and that obtained for the Type B receiver without NAICS assistance information when transmitting the transport format indicated by each reported wideband CQI index subject to interference sources with the same specified  $\hat{E}_s/N_{oc}$  shall be  $\geq \gamma$ ;

**Table 9.3.8.3.1-1 Fading test for single antenna (FDD)**

Parameter		Unit	Cell 1	Cell 2	Cell 3
Bandwidth		MHz	10		
Transmission mode			10	9	9
Downlink power allocation	$\rho_A$	dB	0		
	$\rho_B$	dB	0		
	$\rho_C$	dB	0		
	$\sigma$	dB	0		
Cyclic Prefix			Normal	Normal	Normal
Cell ID			0	1	6
SNR		dB	8.34	N/A	N/A
$\bar{E}_s/N_{oc}$		dB	N/A	3.28	0.74
$\hat{I}_{or}^{(j)}$		dB [mW/15kHz]	-89.66	-94.72	-97.26
$N_{oc}$		dB[mW/15kHz]	-98		
Propagation channel			EPA5	EPA5	EPA5
Correlation and antenna configuration			Low 2 x 2	Low 2 x 2	Low 2 x 2
Cell-specific reference signals			Antenna ports 0,1	Antenna port 0, 1	Antenna port 0, 1
Beamforming Model			As specified in Section B.4.3		
CSI reference signals			Antenna ports 15,16	N/A	N/A
CSI-RS periodicity and subframe offset			5/1	N/A	N/A
CSI-RS reference signal configuration			2	N/A	N/A
Zero-power CSI-RS configuration $l_{CSI-RS}$ / $ZeroPowerCSI-RS$ bitmap		Subframes / bitmap	N/A	1 / 000100000000 0000	1 / 000100000000 00000
Interference model			N/A	As specified in clause B.6.4	As specified in clause B.6.4
CSI process	CSI-RS		CSI-RS	N/A	N/A
	CSI-IM		CSI-IM	N/A	N/A
	Reporting mode		PUCCH 1-1	N/A	N/A
	CodeBookSubsetRestriction bitmap		000001	N/A	N/A
	Reporting periodicity	ms	$N_{pd} = 5$	N/A	N/A
	CQI delay	ms	8	N/A	N/A
	Physical channel for CQI/ PMI reporting		PUSCH (Note 3)	N/A	N/A
	PUCCH Report Type for CQI/PMI		2	N/A	N/A
	PUCCH channel for RI reporting		PUCCH Format 2	N/A	N/A
	PUCCH report type for RI		3	N/A	N/A
	$cqi-pmi-ConfigurationIndex$		2	N/A	N/A
$ri-ConfigIndex$		1	N/A	N/A	
CSI-IM periodicity and subframe offset $T_{CSI-IM} / \Delta_{CSI-IM}$			5/1	N/A	N/A
CSI-IM configuration			6	N/A	N/A
CSI process for PDSCH scheduling			CSI process	N/A	N/A
Quasi-co-located CSI-RS			CSI-RS	N/A	N/A
Quasi-co-located CRS			Same Cell ID as Cell 1	N/A	N/A
Reference measurement channel			Note 2	N/A	N/A
Max number of HARQ transmissions			1	N/A	N/A
NeighCellsInfo-r12 (Note 5)	p-aList-r12		N/A	{dB-6, dB-3, dB0}	{dB-6, dB-3, dB0}
	transmissionModeList-r12		N/A	{2,3,4,8,9}	{2,3,4,8,9}

Note 1:	If the UE reports in an available uplink reporting instance at subframe SF#n based on CQI estimation at a downlink SF not later than SF#(n-4), this reported wideband CQI cannot be applied at the eNB downlink before SF#(n+4)
Note 2:	Reference measurement channel RC.11 FDD according to Table A.4-1 with one sided dynamic OCNG Pattern OP.1 FDD as described in Annex A.5.1.1.
Note 3:	To avoid collisions between CQI/ PMI reports and HARQ-ACK it is necessary to report both on PUSCH instead of PUCCH. PDCCCH DCI format 0 shall be transmitted in downlink SF#1 and #6 to allow periodic CQI/ PMI to multiplex with the HARQ-ACK on PUSCH in uplink subframe SF#0 and #5.
Note 4:	All cells are time-synchronous.
Note 5:	NeighCellsInfo-r12 is described in subclause 6.3.2 of [7].

**Table 9.3.8.3.1-2 Minimum requirement (FDD)**

	Test 1
$\gamma$	0.925
UE Category	$\geq 2$

**9.3.8.3.2 TDD**

For the parameters specified in Table 9.3.8.3.2-1, and using the downlink physical channels specified in Annex C, the minimum requirements are specified in Table 9.3.8.3.2-2 and by the following

- a) the ratio of the throughput obtained for the Type B receiver with NAICS assistance information when transmitting the transport format indicated by each reported wideband CQI index subject to interference sources with specified  $\tilde{E}_i/N_{oc}$  and that obtained for the Type B receiver without NAICS assistance information when transmitting the transport format indicated by each reported wideband CQI index subject to interference sources with the same specified  $\tilde{E}_i/N_{oc}$  shall be  $\geq \gamma$ ;

**Table 9.3.8.3.2-1 Fading test for single antenna (TDD)**



Parameter		Unit	Cell 1	Cell 2	Cell 3
Bandwidth		MHz	10		
Transmission mode			10	9	9
Downlink power allocation	$\rho_A$	dB	0		
	$\rho_B$	dB	0		
	$\rho_C$	dB	0		
	$\sigma$	dB	0		
Uplink downlink configuration			2		
Special subframe configuration			4		
Cyclic Prefix			Normal	Normal	Normal
Cell ID			0	1	6
SNR		dB	8.34	N/A	N/A
$\bar{E}_s/N_{oc}$		dB	N/A	3.28	0.74
$\hat{I}_{or}^{(j)}$		dB [mW/15kHz]	-89.66	-94.72	-97.26
$N_{oc}$		dB[mW/15k Hz]	-98		
Propagation channel			EPA5	EPA5	EPA5
Correlation and antenna configuration			Low 2 x 2	Low 2 x 2	Low 2 x 2
Cell-specific reference signals			Antenna ports 0,1	Antenna port 0,1	Antenna port 0,1
Beamforming Model			As specified in Section B.4.3		
CSI reference signals			Antenna ports 15,16	N/A	N/A
CSI-RS periodicity and subframe offset			5/3	N/A	N/A
CSI-RS reference signal configuration			2	N/A	N/A
Zero-power CSI-RS configuration $I_{CSI-RS} /$ ZeroPowerCSI-RS bitmap		Subframes / bitmap	N/A	3 / 000100000000 0000	3 / 000100000000 0000
Interference model			N/A	As specified in clause B.6.4	As specified in clause B.6.4
CSI process	CSI-RS		CSI-RS	N/A	N/A
	CSI-IM		CSI-IM	N/A	N/A
	Reporting mode		PUCCH 1-1	N/A	N/A
	CodeBookSubsetRestriction on bitmap		000001	N/A	N/A
	Reporting periodicity	ms	$M_{pd} = 5$	N/A	N/A
	CQI delay	ms	8	N/A	N/A
	Physical channel for CQI/PMI reporting		PUSCH (Note 3)	N/A	N/A
	PUCCH Report Type for CQI/PMI		2	N/A	N/A
	PUCCH channel for RI reporting		PUCCH Format 2	N/A	N/A
	PUCCH report type for RI		3	N/A	N/A
	$cqi-pmi-ConfigurationIndex$		3	N/A	N/A
$ri-ConfigIndex$		805 (Note 5)	N/A	N/A	
CSI-IM periodicity and subframe offset $T_{CSI-RS} / \Delta_{CSI-RS}$			5/1	N/A	N/A
CSI-IM configuration			6	N/A	N/A
CSI process for PDSCH scheduling			CSI process	N/A	N/A
Quasi-co-located CSI-RS			CSI-RS	N/A	N/A
Quasi-co-located CRS			Same Cell ID as Cell 1	N/A	N/A
Reference measurement channel			Note 2	N/A	N/A
Max number of HARQ transmissions			1	N/A	N/A
ACK/NACK feedback mode			Multiplexing	N/A	N/A
NeighCellsInfo-r12 (Note 6)	p-aList-r12		N/A	{dB-6, dB-3, dB0}	{dB-6, dB-3, dB0}
	transmissionModelList-r12		N/A	{2,3,4,8,9}	{2,3,4,8,9}

Note 1:	If the UE reports in an available uplink reporting instance at subframe SF#n based on CQI estimation at a downlink SF not later than SF#(n-4), this reported wideband CQI cannot be applied at the eNB downlink before SF#(n+4)
Note 2:	Reference measurement channel RC.11 TDD according to Table A.4-1 with one sided dynamic OCNG Pattern OP.1 TDD as described in Annex A.5.2.1.
Note 3:	To avoid collisions between CQI/ PMI reports and HARQ-ACK it is necessary to report both on PUSCH instead of PUCCH. PDCCH DCI format 0 shall be transmitted in downlink SF#1 and #6 to allow periodic CQI/ PMI to multiplex with the HARQ-ACK on PUSCH in uplink subframe SF#0 and #5.
Note 4:	All cells are time-synchronous.
Note 5:	RI reporting interval is set to the maximum allowable length of 160ms to minimise collisions between RI, CQI/PMI and HARQ-ACK reports. In the case when all three reports collide, it is expected that CQI/PMI reports will be dropped, while RI and HARQ-ACK will be multiplexed. At eNB, CQI report collection shall be skipped every 160ms during performance verification and the reported CQI in subframe SF#7 of the previous frame is applied in downlink subframes until a new CQI (after CQI/PMI dropping) is available.
Note 6:	NeighCellsInfo-r12 is described in subclause 6.3.2 of [7].

Table 9.3.8.3.2-2 Minimum requirement (TDD)

	Test 1
$\gamma$	0.925
UE Category	$\geq 2$

## 9.4 Reporting of Precoding Matrix Indicator (PMI)

The minimum performance requirements of PMI reporting are defined based on the precoding gain, expressed as the relative increase in throughput when the transmitter is configured according to the UE reports compared to the case when the transmitter is using random precoding, respectively. When the transmitter uses random precoding, for each PDSCH allocation a precoder is randomly generated and applied to the PDSCH. A fixed transport format (FRC) is configured for all requirements.

The requirements for transmission mode 6, transmission mode 9 with 4 TX and transmission mode 9 with 8 TX *alternativeCodebookEnabledCLASSB\_K1=TRUE* configured are specified in terms of the ratio

$$\gamma = \frac{t_{ue}}{t_{rnd}}$$

In the definition of  $\gamma$ , for PUSCH 3-1 single PMI and PUSCH 1-2 multiple PMI requirements,  $t_{rnd}$  is 60% of the maximum throughput obtained at  $SNR_{rnd}$  using random precoding, and  $t_{ue}$  the throughput measured at  $SNR_{rnd}$  with precoders configured according to the UE reports;

For the PUCCH 2-1 single PMI requirement,  $t_{rnd}$  is 60% of the maximum throughput obtained at  $SNR_{rnd}$  using random precoding on a randomly selected full-size subband in set S subbands, and  $t_{ue}$  the throughput measured at  $SNR_{rnd}$  with both the precoder and the preferred full-size subband applied according to the UE reports;

For PUSCH 2-2 multiple PMI requirements,  $t_{rnd}$  is 60% of the maximum throughput obtained at  $SNR_{rnd}$  using random precoding on a randomly selected full-size subband in set S subbands, and  $t_{ue}$  the throughput measured at  $SNR_{rnd}$  with both the subband precoder and a randomly selected full-size subband (within the preferred subbands) applied according to the UE reports.

For PUCCH 1-1 single PMI requirement under transmission mode 9 with 4Tx and 8 TX when *alternativeCodebookEnabledCLASSB\_K1=TRUE* configured,  $t_{ue}$  is 70% of the maximum throughput obtained at  $SNR_{follow}$  using the precoders configured according to the UE reports, and  $t_{rnd}$  is the throughput measured at  $SNR_{follow}$  with random precoding.

The requirements for transmission mode 9 with 8 TX and transmission mode 9 with 4TX enhanced codebook are specified in terms of the ratio

$$\gamma = \frac{t_{ue\_follow1\_follow2}}{t_{rnd1\_rnd2}}$$

In the definition of  $\gamma$ , for PUSCH 3-1 single PMI, PUCCH 1-1 single PMI and PUSCH 1-2 multiple PMI requirements,  $t_{follow1\_follow2}$  is 70% of the maximum throughput obtained at  $SNR_{follow1\_follow2}$  using the precoders configured according to the UE reports, and  $t_{rnd1\_rnd2}$  is the throughput measured at  $SNR_{follow1\_follow2}$  with random precoding.

The requirements for transmission mode 9 with 12 TX, 16 TX, 24TX and 32 TX Class A codebook are specified in terms of the ratio

$$\gamma = \frac{t_{ue\_follow1,1\_follow1,2\_follow2}}{t_{rnd1,1\_rnd1,2\_rnd2}}$$

In the definition of  $\gamma$ , for PUSCH 3-1 single PMI and PUSCH 1-2 multiple PMI requirements,  $t_{ue\_follow1,1\_follow1,2\_follow2}$  is 90% of the maximum throughput obtained at  $SNR_{follow1,1\_follow1,2\_follow2}$  using the precoders configured according to the UE reports, and  $t_{rnd1,1\_rnd1,2\_rnd2}$  is the throughput measured at  $SNR_{follow1,1\_follow1,2\_follow2}$  with random precoding.

The requirements for transmission mode 9 with 16 TX Class A *advancedCodebookEnabled=TRUE* configured are specified in terms of the ratio

$$\gamma = \frac{t_{ue\_follow1,1\_follow1,2\_follow1,3\_follow2\_follow\_RPI}}{t_{follow1,1\_follow1,2\_follow1,3\_follow2\_fixed\_RPI}}$$

In the definition of  $\gamma$ ,  $t_{ue\_follow1,1\_follow1,2\_follow1,3\_follow2\_follow\_RPI}$  is [70%] of the maximum throughput obtained at  $SNR_{follow1,1\_follow1,2\_follow1,3\_follow2\_follow\_RPI}$  using the precoders configured according to both the PMI and relative power indicator (RPI) reported by the UE, and  $t_{follow1,1\_follow1,2\_follow1,3\_follow2\_fixed\_RPI}$  is the throughput measured at  $SNR_{follow1,1\_follow1,2\_follow1,3\_follow2\_follow\_RPI}$  using the precoders configured according to the UE reports PMI and fixed RPI equal to 0.

## 9.4.1 Single PMI

### 9.4.1.1 Minimum requirement PUSCH 3-1 (Cell-Specific Reference Symbols)

#### 9.4.1.1.1 FDD

For the parameters specified in Table 9.4.1.1.1-1, and using the downlink physical channels specified in Annex C.3.2, the minimum requirements are specified in Table 9.4.1.1.1-2.

**Table 9.4.1.1.1-1: PMI test for single-layer (FDD)**

Parameter	Unit	Test 1	
Bandwidth	MHz	10	
Transmission mode		6	
Propagation channel		EVA5	
Precoding granularity	PRB	50	
Correlation and antenna configuration		Low 2 x 2	
Downlink power allocation	$\rho_A$	dB	-3
	$\rho_B$	dB	-3
	$\sigma$	dB	0
$N_{oc}^{(j)}$	dB[mW/15kHz]	-98	
Reporting mode		PUSCH 3-1	
Reporting interval	ms	1	
PMI delay (Note 2)	ms	8	
Measurement channel		R. 10 FDD	
OCNG Pattern		OP.1 FDD	
Max number of HARQ transmissions		4	
Redundancy version coding sequence		{0,1,2,3}	
Note 1: For random precoder selection, the precoder shall be updated in each TTI (1 ms granularity).			
Note 2: If the UE reports in an available uplink reporting instance at subframe SF#n based on PMI estimation at a downlink SF not later than SF#(n-4), this reported PMI cannot be applied at the eNB downlink before SF#(n+4).			

**Table 9.4.1.1.1-2 Minimum requirement (FDD)**

Parameter	Test 1
$\gamma$	1.1
UE Category	$\geq 1$

#### 9.4.1.1.2 TDD

For the parameters specified in Table 9.4.1.1.2-1, and using the downlink physical channels specified in Annex C.3.2, the minimum requirements are specified in 9.4.1.1.2-2.

**Table 9.4.1.1.2-1: PMI test for single-layer (TDD)**

Parameter	Unit	Test 1	
Bandwidth	MHz	10	
Transmission mode		6	
Uplink downlink configuration		1	
Special subframe configuration		4	
Propagation channel		EVA5	
Precoding granularity	PRB	50	
Correlation and antenna configuration		Low 2 x 2	
Downlink power allocation	$\rho_A$	dB	-3
	$\rho_B$	dB	-3
	$\sigma$	dB	0
$N_{oc}^{(j)}$	dB[mW/15kHz]	-98	
Reporting mode		PUSCH 3-1	
Reporting interval	ms	1	
PMI delay (Note 2)	ms	10 or 11	
Measurement channel		R.10 TDD	
OCNG Pattern		OP.1 TDD	
Max number of HARQ transmissions		4	
Redundancy version coding sequence		{0,1,2,3}	
ACK/NACK feedback mode		Multiplexing	
Note 1:	For random precoder selection, the precoder shall be updated in each available downlink transmission instance.		
Note 2:	If the UE reports in an available uplink reporting instance at subframe SF#n based on PMI estimation at a downlink SF not later than SF#(n-4), this reported PMI cannot be applied at the eNB downlink before SF#(n+4).		

**Table 9.4.1.1.2-2: Minimum requirement (TDD)**

Parameter	Test 1
$\gamma$	1.1
UE Category	$\geq 1$

## 9.4.1.2 Minimum requirement PUCCH 2-1 (Cell-Specific Reference Symbols)

### 9.4.1.2.1 FDD

For the parameters specified in Table 9.4.1.2.1-1, and using the downlink physical channels specified in Annex C.3.2, the minimum requirements are specified in Table 9.4.1.2.1-2.

Table 9.4.1.2.1-1: PMI test for single-layer (FDD)

Parameter	Unit	Test 1	
Bandwidth	MHz	10	
Transmission mode		6	
Propagation channel		EVA5	
Correlation and antenna configuration		Low 4 x 2	
Downlink power allocation	$\rho_A$	dB	-6
	$\rho_B$	dB	-6
	$\sigma$	dB	3
$N_{oc}^{(j)}$	dB[mW/15kHz]	-98	
PMI delay	ms	8 or 9	
Reporting mode		PUCCH 2-1 (Note 6)	
Reporting periodicity	ms	$N_{pd} = 2$	
Physical channel for CQI reporting		PUSCH (Note 3)	
PUCCH Report Type for wideband CQI/PMI		2	
PUCCH Report Type for subband CQI		1	
Measurement channel		R.14-1 FDD	
OCNG Pattern		OP.1/2 FDD	
Precoding granularity	PRB	6 (full size)	
Number of bandwidth parts (J)		3	
K		1	
<i>cqi-pmi-ConfigIndex</i>		1	
Max number of HARQ transmissions		4	
Redundancy version coding sequence		{0,1,2,3}	
Note 1:	For random precoder selection, the precoder shall be updated every two TTI (2 ms granularity).		
Note 2:	If the UE reports in an available uplink reporting instance at subframe SF#n based on PMI estimation at a downlink SF not later than SF#(n-4), this reported PMI cannot be applied at the eNB downlink before SF#(n+4).		
Note 3:	To avoid collisions between HARQ-ACK and wideband CQI/PMI or subband CQI, it is necessary to report both on PUSCH instead of PUCCH. PDCCH DCI format 0 shall be transmitted in downlink SF#1, #3, #7 and #9 to allow periodic CQI to multiplex with the HARQ-ACK on PUSCH in uplink subframe SF#5, #7, #1 and #3.		
Note 4:	Reports for the short subband (having 2RBs in the last bandwidth part) are to be disregarded and instead data is to be transmitted on the most recently used subband for bandwidth part with j=1.		
Note 5:	In the case where wideband PMI is reported, data is to be transmitted on the most recently used subband.		
Note 6:	The bit field for PMI confirmation in DCI format 1B shall be mapped to "0" and TPMI information shall indicate the codebook index used in Table 6.3.4.2.3-2 of TS36.211 [4] according to the latest PMI report on PUCCH.		

Table 9.4.1.2.1-2: Minimum requirement (FDD)

	Test 1
$\gamma$	1.2
UE Category	$\geq 1$

## 9.4.1.2.2 TDD

For the parameters specified in Table 9.4.1.2.2-1, and using the downlink physical channels specified in Annex C.3.2, the minimum requirements are specified in Table 9.4.1.2.2-2.

Table 9.4.1.2.2-1: PMI test for single-layer (TDD)

Parameter	Unit	Test 1	
Bandwidth	MHz	10	
Transmission mode		6	
Uplink downlink configuration		1	
Special subframe configuration		4	
Propagation channel		EVA5	
Correlation and antenna configuration		Low 4 x 2	
Downlink power allocation	$\rho_A$	dB	-6
	$\rho_B$	dB	-6
	$\sigma$	dB	3
$N_{oc}^{(j)}$	dB[mW/15kHz]	-98	
PMI delay	ms	10	
Reporting mode		PUCCH 2-1 (Note 6)	
Reporting periodicity	ms	$N_P = 5$	
Physical channel for CQI reporting		PUSCH (Note 3)	
PUCCH Report Type for wideband CQI/PMI		2	
PUCCH Report Type for subband CQI		1	
Measurement channel		R.14-1 TDD	
OCNG Pattern		OP.1/2 TDD	
Precoding granularity	PRB	6 (full size)	
Number of bandwidth parts ( $J$ )		3	
$K$		1	
<i>cqi-pmi-ConfigIndex</i>		4	
Max number of HARQ transmissions		4	
Redundancy version coding sequence		{0,1,2,3}	
ACK/NACK feedback mode		Multiplexing	
<p>Note 1: For random precoder selection, the precoder shall be updated in each available downlink transmission instance.</p> <p>Note 2: If the UE reports in an available uplink reporting instance at subframe SF#n based on PMI estimation at a downlink SF not later than SF#(n-4), this reported PMI cannot be applied at the eNB downlink before SF#(n+4).</p> <p>Note 3: To avoid collisions between HARQ-ACK and wideband CQI/PMI or subband CQI it is necessary to report both on PUSCH instead of PUCCH. PDCCCH DCI format 0 shall be transmitted in downlink SF#4 and #9 to allow periodic CQI to multiplex with the HARQ-ACK on PUSCH in uplink subframe SF#8 and #3.</p> <p>Note 4: Reports for the short subband (having 2RBs in the last bandwidth part) are to be disregarded and instead data is to be transmitted on the most recently used subband for bandwidth part with <math>j=1</math>.</p> <p>Note 5: In the case where wideband PMI is reported, data is to be transmitted on the most recently used subband.</p> <p>Note 6: The bit field for PMI confirmation in DCI format 1B shall be mapped to "0" and TPMI information shall indicate the codebook index used in Table 6.3.4.2.3-2 of TS36.211 [4] according to the latest PMI report on PUCCH.</p>			

**Table 9.4.1.2.2-2: Minimum requirement (TDD)**

	Test 1
$\gamma$	1.2
UE Category	$\geq 1$

### 9.4.1.3 Minimum requirement PUSCH 3-1 (CSI Reference Symbol)

#### 9.4.1.3.1 FDD

For the parameters specified in Table 9.4.1.3.1-1, and using the downlink physical channels specified in Annex C.3.2, the minimum requirements are specified in Table 9.4.1.3.1-2.



**Table 9.4.1.3.1-1: PMI test for single-layer (FDD)**

Parameter	Unit	Test 1	Test 2	Test 3
Bandwidth	MHz	10	10	10
Transmission mode		9	9	9
Propagation channel		EPA5	EPA5	EPA5
Precoding granularity	PRB	50	50	50
Correlation and antenna configuration		Low ULA 4 x 2	Low ULA 4 x 2	Low ULA 4 x 2
Cell-specific reference signals		Antenna ports 0,1	Antenna ports 0,1	Antenna ports 0,1
CSI reference signals		Antenna ports 15,...,18	Antenna ports 15,...,18	Antenna ports 15,...,18
Beamforming model		Annex B.4.3	Annex B.4.3	Annex B.4.3
FrequencyDensit yBeamformed		N/A	1	1
NZP- TransmissionComb Beamformed		N/A	N/A	N/A
csi-RS-NZP-mode		N/A	aperiodic	multiShot
NumberActivatedAperi odicCSI-RS- Resources		N/A	1	NA
CSI-RS- ConfigNZPAperiodic		N/A	6,7 (Note 4)	NA
NumberActivatedCSI- RS-Resources		N/A	NA	1
eMIMO-Type		N/A	ClassB	ClassB
alternativeCodebookE nableCLASSB_K1		N/A	FALSE	FALSE
CSI-RS periodicity and subframe offset $T_{CSI-RS} / \Delta_{CSI-RS}$		5/ 1	N/A	5/ 1
CSI-RS reference signal configuration		6	N/A	6,7 (Note 5,6)
CodeBookSubsetRestr iction bitmap		0x0000 0000 0000 FFFF	0x0000 0000 0000 FFFF	0x0000 0000 0000 FFFF
Downlink power allocation	$\rho_A$	dB	0	0
	$\rho_B$	dB	0	0
	$\rho_C$	dB	-3	-3
	$\sigma$	dB	-3	-3
$N_{oc}^{(j)}$	dB[mW/15kHz]	-98	-98	-98
Reporting mode		PUSCH 3-1	PUSCH 3-1	PUSCH 3-1
Reporting interval	ms	5	5	5
PMI delay (Note 2)	ms	8	8	8
Measurement channel		R.44 FDD	R.44 FDD	R.44 FDD
OCNG Pattern		OP.1 FDD	OP.1 FDD	OP.1 FDD
Max number of HARQ transmissions		4	4	4
Redundancy version coding sequence		{0,1,2,3}	{0,1,2,3}	{0,1,2,3}

Note 1:	For random precoder selection, the precoder shall be updated in each TTI (1 ms granularity).
Note 2:	If the UE reports in an available uplink reporting instance at subframe SF#n based on PMI estimation at a downlink SF not later than SF#(n-4), this reported PMI cannot be applied at the eNB downlink before SF#(n+4).
Note 3:	PDSCH_RA= 0 dB, PDSCH_RB= 0 dB in order to have the same PDSCH and OCNG power per subcarrier at the receiver.
Note 4:	Only one of these two aperiodic NZP CSI-RS resources will be randomly selected and activated during test. The selected aperiodic NZP CSI-RS is transmitted in every subframe #1 and #6.
Note 5:	Through MAC CE, one of these two periodic NZP CSI-RS resources will be activated and the other one will be deactivated in an alternative way. The activation and deactivation command will be transmitted in sub-frame #0 per [10000] ms.
Note 6:	When activation and/or deactivation command through MAC CE is transmitted at subframe n, the scheduled PDSCH transmission will be skipped for the subsequent 25 subframes.

**Table 9.4.1.3.1-2: Minimum requirement (FDD)**

Parameter	Test 1	Test 2	Test 3
$\gamma$	1.2	[1.2]	[1.2]
UE Category	$\geq 1$	$\geq 2$	$\geq 2$
Note 1: For UE that indicates support of csi-RS-NZP-mode 'aperiodic' and/or 'multiShot', test 2 and/or test 3 will be run and test 1 will be skipped. Otherwise, test 1 will be run and test 2 and test 3 will be skipped.			

#### 9.4.1.3.2 TDD

For the parameters specified in Table 9.4.1.3.2-1, and using the downlink physical channels specified in Annex C.3.2, the minimum requirements are specified in Table 9.4.1.3.2-2.

**Table 9.4.1.3.2-1: PMI test for single-layer (TDD)**

Parameter	Unit	Test 1	Test 2	Test 3
Bandwidth	MHz	10	10	10
Transmission mode		9	9	9
Uplink downlink configuration		1	1	1
Special subframe configuration		4	4	4
Propagation channel		EVA5	EVA5	EVA5
Precoding granularity	PRB	50	50	50
Antenna configuration		8 x 2	8 x 2	8 x 2
Correlation modeling		High, Cross polarized	High, Cross polarized	High, Cross polarized
Cell-specific reference signals		Antenna ports 0,1	Antenna ports 0,1	Antenna ports 0,1
CSI reference signals		Antenna ports 15,...,22	Antenna ports 15,...,22	Antenna ports 15,...,22
Beamforming model		Annex B.4.3	Annex B.4.3	Annex B.4.3
FrequencyDensityBeamformed		N/A	1	1
NZP-TransmissionCombBeamformed		N/A	N/A	N/A
csi-RS-NZP-mode		N/A	aperiodic	multiShot
NumberActivatedAperiodicCSI-RS-Resources		N/A	1	N/A
CSI-RS-ConfigNZPAperiodic		N/A	0,1 (Note 5)	N/A
NumberActivatedCSI-RS-Resources		N/A	N/A	1
eMIMO-Type		N/A	ClassB	ClassB
CSI-RS periodicity and subframe offset $T_{csi-rs} / \Delta_{csi-rs}$		5/ 4	N/A	5/ 4
CSI-RS reference signal configuration		0	N/A	0,1 (Note 6,7)
CodeBookSubsetRestriction bitmap		0x0000 0000 001F FFE0 0000 0000 FFFF	0x0000 0000 001F FFE0 0000 0000 FFFF	0x0000 0000 001F FFE0 0000 0000 FFFF
Downlink power allocation	$\rho_A$	dB	0	0
	$\rho_B$	dB	0	0
	$P_c$	dB	-6	-6
	$\sigma$	dB	-3	-3
$N_{oc}^{(j)}$	dB[mW/15kHz]	-98	-98	-98
Reporting mode		PUSCH 3-1	PUSCH 3-1	PUSCH 3-1
Reporting interval	ms	5	5	5
PMI delay (Note 2)	ms	10	10	10
Measurement channel		R.45-1 TDD for UE Category 1, R.45 TDD for UE Category $\geq 2$	R.45 TDD	R.45 TDD
OCNG Pattern		OP.7 TDD for UE Category 1, and OP.1 TDD for UE Category $\geq 2$	OP.1 TDD	OP.1 TDD
Max number of HARQ transmissions		4	4	4
Redundancy version coding sequence		{0,1,2,3}	{0,1,2,3}	{0,1,2,3}

ACK/NACK feedback mode	Multiplexing	Multiplexing	Multiplexing
Note 1:	For random precoder selection, the precoder shall be updated in each TTI (1 ms granularity).		
Note 2:	If the UE reports in an available uplink reporting instance at subframe SF#n based on PMI estimation at a downlink SF not later than SF#(n-4), this reported PMI cannot be applied at the eNB downlink before SF#(n+4).		
Note 3:	PDCCH DCI format 0 with a trigger for aperiodic CQI shall be transmitted in downlink SF#4 and #9 to allow aperiodic CQI/PMI/RI to be transmitted on uplink SF#3 and #8.		
Note 4:	Randomization of the principle beam direction shall be used as specified in B.2.3A.4		
Note 5:	Only one of these two aperiodic NZP CSI-RS resources will be randomly selected and activated during test. The selected aperiodic NZP CSI-RS is transmitted in every subframe #4 and #9.		
Note 6:	Through MAC CE, one of these two periodic NZP CSI-RS resources will be activated and the other one will be deactivated in an alternative way. The activation and deactivation command will be transmitted in sub-frame #0 per [10000] ms.		
Note 7:	When activation and/or deactivation command through MAC CE is transmitted at subframe n, the scheduled PDSCH transmission will be skipped for the subsequent 25 subframes.		

Table 9.4.1.3.2-2: Minimum requirement (TDD)

Parameter	Test 1	Test 2	Test 3
$\gamma$	3	[3]	[3]
UE Category	$\geq 1$	$\geq 2$	$\geq 2$
Note 1:	For UE that indicates support of csi-RS-NZP-mode 'aperiodic' and/or 'multiShot', test 2 and/or test 3 will be run and test 1 will be skipped. Otherwise, test 1 will be run and test 2 and test 3 will be skipped.		

### 9.4.1.3.3 FDD (with Class A 12Tx codebook)

For the parameters specified in Table 9.4.1.3.3-1, and using the downlink physical channels specified in Annex C.3.2, the minimum requirements are specified in Table 9.4.1.3.3-2.

Table 9.4.1.3.3-1: PMI test for single-layer (FDD)

Parameter	Unit	Test 1	
Bandwidth	MHz	10	
Transmission mode		9	
Propagation channel		EPA5	
Precoding granularity	PRB	50	
Correlation and antenna configuration		High 2D XP 12(2,3,2) x 2	
Cell-specific reference signals		Antenna ports 0,1	
CSI reference signals		Antenna ports 15,...,26	
Beamforming model		Annex B.4.3	
CDM Type		CDM2	
CSI-RS periodicity and subframe offset $T_{\text{CSI-RS}} / \Delta_{\text{CSI-RS}}$		5/ 1	
NZP-CSI-RS-Configuration-List		{0,1,2}	
eMIMO-Type		Class A	
codebookConfig-N1		2	
codebookConfig-N2		3	
codebook-Over-Sampling-RateConfig-O1		8	
codebook-Over-Sampling-RateConfig-O2		4	
Codebook-Config		Note 5	
codebookSubsetRestriction-1		0x01 FFFF FFFF FFFF FFFF FFFF FFFF FFFF FFFF FFFF FFFF FFFF FFFF	
codebookSubsetRestriction-2		Codebook-Config 1: 0000 0000 1111 Codebook-Config 2,3,4: 0x 00 000000 0000 FFFF	
Downlink power allocation	$\rho_A$	dB	0
	$\rho_B$	dB	0
	$P_c$	dB	-8
	$\sigma$	dB	-3
$N_{oc}^{(j)}$	dB[mW/15kHz]	-98	
Reporting mode		PUSCH 3-1	
Reporting interval	ms	5	
PMI delay (Note 2)	ms	8	
Measurement channel		R.77 FDD	
Rank Number of PDSCH		1	
OCNG Pattern		OP.1 FDD	
Max number of HARQ transmissions		4	
Redundancy version coding sequence		{0,1,2,3}	
Note 1: For random precoder selection, the precoder shall be updated in each TTI (1 ms granularity).			
Note 2: If the UE reports in an available uplink reporting instance at subframe SF#n based on PMI estimation at a downlink SF not later than SF#(n-4), this reported PMI cannot be applied at the eNB downlink before SF#(n+4).			
Note 3: PDSCH_RA= 0 dB, PDSCH_RB= 0 dB in order to have the same PDSCH and OCNG power per subcarrier at the receiver.			
Note 4: Randomization of the principle beam direction shall be used as specified in B.2.3B.4.			
Note 5: Value of parameter codebookConfig shall be random selected one value from UE supported codebook configurations.			

**Table 9.4.1.3.3-2: Minimum requirement (FDD)**

Parameter	Test 1
$\gamma$	2.5
UE Category	$\geq 2$

**9.4.1.3.4 TDD (with Class A 12Tx codebook)**

For the parameters specified in Table 9.4.1.3.4-1, and using the downlink physical channels specified in Annex C.3.2, the minimum requirements are specified in Table 9.4.1.3.4-2.



**Table 9.4.1.3.4-1: PMI test for single-layer (TDD)**

Parameter	Unit	Test 1	
Bandwidth	MHz	10	
Transmission mode		9	
Uplink downlink configuration		1	
Special subframe configuration		4	
Propagation channel		EPA5	
Precoding granularity	PRB	50	
Correlation and antenna configuration		High 2D XP 12(2,3,2) x 2	
Cell-specific reference signals		Antenna ports 0,1	
CSI reference signals		Antenna ports 15,...,26	
Beamforming model		Annex B.4.3	
CDM Type		CDM2	
CSI-RS periodicity and subframe offset $T_{\text{CSI-RS}} / \Delta_{\text{CSI-RS}}$		5/ 4	
NZP-CSI-RS-Configuration-List		{0,1,2}	
eMIMO-Type		Class A	
codebookConfig-N1		2	
codebookConfig-N2		3	
codebook-Over-Sampling-RateConfig-O1		8	
codebook-Over-Sampling-RateConfig-O2		4	
Codebook-Config		Note 5	
codebookSubsetRestriction-1		0x01 FFFF FFFF FFFF FFFF FFFF FFFF FFFF FFFF FFFF FFFF FFFF FFFF	
codebookSubsetRestriction-2		Codebook-Config 1: 0000 0000 1111 Codebook-Config 2,3,4: 0x 00 000000 0000 FFFF	
Downlink power allocation	$\rho_A$	dB	0
	$\rho_B$	dB	0
	$\rho_C$	dB	-8
	$\sigma$	dB	-3
$N_{oc}^{(j)}$	dB[mW/15kHz]	-98	
Reporting mode		PUSCH 3-1	
Reporting interval	ms	5	
PMI delay (Note 2)	ms	10	
Measurement channel		R.77 TDD	
Rank Number of PDSCH		1	
OCNG Pattern		OP.1 TDD	
Max number of HARQ transmissions		4	
Redundancy version coding sequence		{0,1,2,3}	
ACK/NACK feedback mode		Multiplexing	

Note 1:	For random precoder selection, the precoder shall be updated in each TTI (1 ms granularity).
Note 2:	If the UE reports in an available uplink reporting instance at subframe SF#n based on PMI estimation at a downlink SF not later than SF#(n-4), this reported PMI cannot be applied at the eNB downlink before SF#(n+4).
Note 3:	PDCCH DCI format 0 with a trigger for aperiodic CQI shall be transmitted in downlink SF#4 and #9 to allow aperiodic CQI/PMI/RI to be transmitted on uplink SF#3 and #8.
Note 4:	Randomization of the principle beam direction shall be used as specified in B.2.3B.4.
Note 5:	Value of parameter codebookConfig shall be random selected one value from UE supported codebook configurations.

**Table 9.4.1.3.4-2: Minimum requirement (TDD)**

Parameter	Test 1
$\gamma$	2.5
UE Category	$\geq 2$

#### 9.4.1.3.5 FDD (with Class A 24Tx codebook)

For the parameters specified in Table 9.4.1.3.5-1, and using the downlink physical channels specified in Annex C.3.2, the minimum requirements are specified in Table 9.4.1.3.5-2.

Table 9.4.1.3.5-1: PMI test for dual-layer (FDD)

Parameter	Unit	Test 1a	Test 1b	
Bandwidth	MHz	10	10	
Transmission mode		9	9	
Propagation channel		EPA5	EPA5	
Precoding granularity	PRB	50	50	
Correlation and antenna configuration		High 2D XP 24(3,4,2) x 2	High 2D XP 24(3,4,2) x 2	
Cell-specific reference signals		Antenna ports 0,1	Antenna ports 0,1	
CSI reference signals		Antenna ports 15,...,38	Antenna ports 15,...,38	
Beamforming model		Annex B.4.3	Annex B.4.3	
CDM Type		CDM4	CDM4	
CSI-RS periodicity and subframe offset $T_{CSI-RS} / \Delta_{CSI-RS}$		5/ 1	5/ 1	
FrequencyDensityNonPrecoded NZIP-		1	1/3	
TransmissionCombListNonprecoded NZIP-CSI-RS-Configuration-List		N/A	{0,1,2}	
eMIMO-Type		{0,1,2}	{0,1,2}	
codebookConfig-N1		Class A	Class A	
codebookConfig-N2		3	3	
codebook-Over-Sampling-RateConfig-O1		4	4	
codebook-Over-Sampling-RateConfig-O2		8	8	
Codebook-Config		4	4	
codebookSubsetRestriction-1		Note 5 0x02 FFFF	Note 5 0x02 FFFF	
codebookSubsetRestriction-2		Codebook-Config 1: 0000 1111 0000 Codebook-Config 2,3,4: 0x 00 0000 FFFF 0000	Codebook-Config 1: 0000 1111 0000 Codebook-Config 2,3,4: 0x 00 0000 FFFF 0000	
Downlink power allocation	$\rho_A$	dB	0	0
	$\rho_B$	dB	0	0
	$P_c$	dB	-8	-8
	$\sigma$	dB	-3	-3
$N_{oc}^{(j)}$	dB[mW/ 15kHz]	-98	-98	
Reporting mode		PUSCH 3-1	PUSCH 3-1	
Reporting interval	ms	5	5	
PMI delay (Note 2)	ms	8	8	
Measurement channel		R.88 FDD	R.88A FDD	
Rank Number of PDSCH		2	2	
OCNG Pattern		OP.1 FDD	OP.1 FDD	
Max number of HARQ transmissions		4	4	
Redundancy version coding sequence		{0,1,2,3}	{0,1,2,3}	
Note 1: For random precoder selection, the precoder shall be updated in each TTI (1 ms granularity).				
Note 2: If the UE reports in an available uplink reporting instance at subframe SF#n based on PMI estimation at a downlink SF not later than SF#(n-4), this reported PMI cannot be applied at the eNB downlink before SF#(n+4).				
Note 3: PDSCH_RA= 0 dB, PDSCH_RB= 0 dB in order to have the same PDSCH and OCNG power per subcarrier at the receiver.				
Note 4: Randomization of the principle beam direction shall be used as specified in B.2.3B.4.				
Note 5: Value of parameter codebookConfig shall be random selected one value from UE supported codebook configurations.				

**Table 9.4.1.3.5-2: Minimum requirement (FDD)**

Parameter	Test 1a	Test 1b
$\gamma$	[3.5]	[3.5]
UE Category	$\geq 2$	$\geq 2$
Note1:	For UE that indicates support of density reduction for Class A, test 1b will be run and test 1a will be skipped. Otherwise, test 1a will be run and test 1b will be skipped.	

**9.4.1.3.6 TDD (with Class A 24Tx codebook)**

For the parameters specified in Table 9.4.1.3.6-1, and using the downlink physical channels specified in Annex C.3.2, the minimum requirements are specified in Table 9.4.1.3.6-2.

**Table 9.4.1.3.6-1: PMI test for dual-layer (TDD)**

Parameter	Unit	Test 1a	Test 1b	
Bandwidth	MHz	10	10	
Transmission mode		9	9	
Uplink downlink configuration		1	1	
Special subframe configuration		4	4	
Propagation channel		EPA5	EPA5	
Precoding granularity	PRB	50	50	
Correlation and antenna configuration		High 2D XP 24(3,4,2) x 2	High 2D XP 24(3,4,2) x 2	
Cell-specific reference signals		Antenna ports 0,1	Antenna ports 0,1	
CSI reference signals		Antenna ports 15,...,38	Antenna ports 15,...,38	
Beamforming model		Annex B.4.3	Annex B.4.3	
CDM Type		CDM4	CDM4	
CSI-RS periodicity and subframe offset $T_{CSI-RS} / \Delta_{CSI-RS}$		5/4	5/4	
FrequencyDensityNonPrecoded		1	1/3	
NZP-TransmissionCombListNonprecoded		NA	{0,1,2}	
NZP-CSI-RS-Configuration-List		{0,1,2}	{0,1,2}	
eMIMO-Type		Class A	Class A	
codebookConfig-N1		3	3	
codebookConfig-N2		4	4	
codebook-Over-Sampling-RateConfig-O1		8	8	
codebook-Over-Sampling-RateConfig-O2		4	4	
Codebook-Config		Note 5	Note 5	
codebookSubsetRestriction-1		0x02 FFFF	0x02 FFFF	
codebookSubsetRestriction-2		Codebook-Config 1: 0000 1111 0000 Codebook-Config 2,3,4: 0x 00 0000 FFFF 0000	Codebook-Config 1: 0000 1111 0000 Codebook-Config 2,3,4: 0x 00 0000 FFFF 0000	
Downlink power allocation	$\rho_A$	dB	0	0
	$\rho_B$	dB	0	0
	$P_c$	dB	-8	-8
	$\sigma$	dB	-3	-3
$N_{oc}^{(j)}$	dB[mW/1 5kHz]	-98	-98	
Reporting mode		PUSCH 3-1	PUSCH 3-1	
Reporting interval	ms	5	5	
PMI delay (Note 2)	ms	10	10	
Measurement channel		R.88 TDD	R.88A TDD	
Rank Number of PDSCH		2	2	
OCNG Pattern		OP.1 TDD	OP.1 TDD	
Max number of HARQ transmissions		4	4	
Redundancy version coding sequence		{0,1,2,3}	{0,1,2,3}	
ACK/NACK feedback mode		Multiplexing	Multiplexing	

Note 1:	For random precoder selection, the precoder shall be updated in each TTI (1 ms granularity).
Note 2:	If the UE reports in an available uplink reporting instance at subframe SF#n based on PMI estimation at a downlink SF not later than SF#(n-4), this reported PMI cannot be applied at the eNB downlink before SF#(n+4).
Note 3:	PDCCCH DCI format 0 with a trigger for aperiodic CQI shall be transmitted in downlink SF#4 and #9 to allow aperiodic CQI/PMI/RI to be transmitted on uplink SF#3 and #8.
Note 4:	Randomization of the principle beam direction shall be used as specified in B.2.3B.4.
Note 5:	Value of parameter codebookConfig shall be random selected one value from UE supported codebook configurations.

**Table 9.4.1.3.6-2: Minimum requirement (TDD)**

Parameter	Test 1a	Test 1b
$\gamma$	[3.0]	[3.0]
UE Category	$\geq 2$	$\geq 2$
Note1:	For UE that indicates support of density reduction for Class A, test 1b will be run and test 1a will be skipped. Otherwise, test 1a will be run and test 1b will be skipped.	

#### 9.4.1.4 Minimum requirement PUCCH 1-1 (CSI Reference Symbol)

##### 9.4.1.4.1 FDD (with 4Tx enhanced codebook)

For the parameters specified in Table 9.4.1.4.1-1, and using the downlink physical channels specified in Annex C.3.2, the minimum requirements are specified in Table 9.4.1.4.1-2.



Table 9.4.1.4.1-1 PMI test for single-layer (FDD)

Parameter	Unit	Test 1	
Bandwidth	MHz	10	
Transmission mode		9	
Propagation channel		EPA5	
Precoding granularity	PRB	50	
Correlation and antenna configuration		High XP 4 x 2	
Beamforming model		Annex B.4.3	
Cell-specific reference signals		Antenna ports 0,1	
CSI reference signals		Antenna ports 15,....,18	
CSI-RS periodicity and subframe offset $T_{CSI-RS} / \Delta_{CSI-RS}$ $T_{CSI-RS} / \Delta_{CSI-RS}$		5/ 1	
CSI-RS reference signal configuration		6	
CodeBookSubsetRestriction bitmap		0x0000 0000 0000 FFFF 0000 00FF	
Downlink power allocation	$\rho_A$	dB	0
	$\rho_B$	dB	0
	$P_c$	dB	-3
	$\sigma$	dB	-3
$N_{oc}^{(j)}$	dB[mW/15kHz]	-98	
Reporting mode		PUCCH 1-1 submode1	
Reporting interval	ms	5	
PMI delay (Note 2)	ms	10	
Physical channel for CQI/PMI reporting		PUSCH (Note 3)	
PUCCH Report Type for CQI/second PMI		2b	
Physical channel for RI reporting		PUSCH	
PUCCH Report Type for RI/ first PMI		5	
<i>cqi-pmi-ConfigurationIndex</i>		4	
<i>ri-ConfigIndex</i>		1	
Measurement channel		R.60 FDD	
OCNG Pattern		OP.1 FDD	
Max number of HARQ transmissions		4	
Redundancy version coding sequence		{0,1,2,3}	
alternativeCodeBookEnable dFor4TX-r12		True	
<p>Note 1: For random precoder selection, the precoder shall be updated in each TTI (1 ms granularity)</p> <p>Note 2: If the UE reports in an available uplink reporting instance at subframe SF#n based on PMI estimation at a downlink SF not later than SF#(n-4), this reported PMI cannot be applied at the eNB downlink before SF#(n+4).</p> <p>Note 3: To avoid collisions between CQI/PMI reports and HARQ-ACK it is necessary to report both on PUSCH instead of PUCCH.</p> <p>Note 4: PDSCH_RA= 0 dB, PDSCH_RB= 0 dB in order to have the same PDSCH and OCNG power per subcarrier at the receiver.</p> <p>Note 5: Randomization of the principle beam direction shall be used as specified in B.2.3A.4</p>			

**Table 9.4.1.4.1-2 Minimum requirement (FDD)**

Parameter	Test 1
$\gamma$	1.8
UE Category	$\geq 1$

**9.4.1.4.2 TDD (with 4Tx enhanced codebook)**

For the parameters specified in Table 9.4.1.4.2-1, and using the downlink physical channels specified in Annex C.3.2, the minimum requirements are specified in Table 9.4.1.4.2-2.

**Table 9.4.1.4.2-1 PMI test for single-layer (TDD)**

Parameter	Unit	Test 1	
Bandwidth	MHz	10	
Transmission mode		9	
Uplink downlink configuration		1	
Special subframe configuration		4	
Propagation channel		EPA5	
Precoding granularity	PRB	50	
Correlation and antenna configuration		High XP 4 x 2	
Beamforming model		Annex B.4.3	
Cell-specific reference signals		Antenna ports 0,1	
CSI reference signals		Antenna ports 15,...,18	
CSI-RS periodicity and subframe offset $T_{\text{CSI-RS}} / \Delta_{\text{CSI-RS}}$		5/4	
CSI-RS reference signal configuration		6	
CodeBookSubsetRestriction bitmap		0x0000 0000 0000 FFFF 0000 00FF	
Downlink power allocation	$\rho_A$	dB	0
	$\rho_B$	dB	0
	$P_c$	dB	-3
	$\sigma$	dB	-3
$N_{oc}^{(j)}$	dB[mW/15kHz]	-98	
Reporting mode		PUCCH 1-1 submode1	
Reporting interval	ms	5	
PMI delay (Note 2)	ms	15	
Physical channel for CQI/PMI reporting		PUSCH (Note 3)	
PUCCH Report Type for CQI/second PMI		2b	
Physical channel for RI reporting		PUSCH	
PUCCH Report Type for RI/first PMI		5	
<i>cqi-pmi-ConfigurationIndex</i>		4	
<i>ri-ConfigIndex</i>		1	
Measurement channel		R.60 TDD	
OCNG Pattern		OP.1 TDD	
Max number of HARQ transmissions		4	
Redundancy version coding sequence		{0,1,2,3}	
ACK/NACK feedback mode		Multiplexing	
alternativeCodeBookEnable dFor4TX-r12		True	
Note 1:	For random precoder selection, the precoder shall be updated in each TTI (1 ms granularity)		
Note 2:	If the UE reports in an available uplink reporting instance at subframe SF#n based on PMI estimation at a downlink SF not later than SF#(n-4), this reported PMI cannot be applied at the eNB downlink before SF#(n+4).		
Note 3:	To avoid collisions between CQI/PMI reports and HARQ-ACK it is necessary to report both on PUSCH instead of PUCCH.		
Note 4:	PDCCH DCI format 0 with a trigger for aperiodic CQI shall be transmitted in downlink SF#4 and #9 to allow aperiodic CQI/PMI/RI to be transmitted on uplink SF#3 and #8.		
Note 5:	Randomization of the principle beam direction shall be used as specified in B.2.3A.4.		

**Table 9.4.1.4.2-2 Minimum requirement (TDD)**

Parameter	Test 1
$\gamma$	1.8
UE Category	$\geq 1$

**9.4.1.4.3 FDD (with Class B alternative codebook for one CSI-RS resource configured)**

For the parameters specified in Table 9.4.1.4.3-1, and using the downlink physical channels specified in Annex C.3.2, the minimum requirements are specified in Table 9.4.1.4.3-2.

Table 9.4.1.4.3-1 PMI test for single-layer (FDD)

Parameter	Unit	Test 1	Test 1a	
Bandwidth	MHz	10	10	
Transmission mode		9	9	
Propagation channel		EPA5	EPA5	
Precoding granularity	PRB	50	50	
Correlation and antenna configuration		ULA Low 4 x 2	ULA Low 4 x 2	
Beamforming model		Annex B.4.3	Annex B.4.3	
Cell-specific reference signals		Antenna ports 0,1	Antenna ports 0,1	
CSI reference signals		Antenna ports 15,...,18	Antenna ports 15,...,18	
FrequencyDensityBeamformed		1	1/2	
NZP-TransmissionCombBeamformed		N/A	0	
CSI-RS periodicity and subframe offset $T_{\text{CSI-RS}} / \Delta_{\text{CSI-RS}}$		5/1	5/1	
CSI-RS reference signal configuration		6	6	
eMIMO-Type		Class B	Class B	
alternativeCodebookEnabled CLASSB_K1		TRUE	TRUE	
codebookSubsetRestriction-3		00 0000 0000 0000 1111 1111	00 0000 0000 0000 1111 1111	
Downlink power allocation	$\rho_A$	dB	0	0
	$\rho_B$	dB	0	0
	$\rho_C$	dB	-6	-6
	$\sigma$	dB	-3	-3
$N_{oc}^{(j)}$	dB[mW/15kHz]	-98	-98	
Reporting mode		PUCCH 1-1	PUCCH 1-1	
Reporting interval	ms	5	5	
PMI delay (Note 2)	ms	10	10	
Physical channel for CQI/PMI reporting		PUSCH (Note 3)	PUSCH (Note 3)	
PUCCH Report Type for CQI/PMI		2	2	
Physical channel for RI reporting		PUSCH	PUSCH	
PUCCH Report Type for RI		3	3	
<i>cqi-pmi-ConfigurationIndex</i>		2	2	
<i>ri-ConfigIndex</i>		1	1	
Measurement channel		R.45 FDD	R.45A-2 FDD	
Rank number of PDSCH		1	1	
OCNG Pattern		OP.1 FDD	OP.1 FDD	
Max number of HARQ transmissions		4	4	
Redundancy version coding sequence		{0,1,2,3}	{0,1,2,3}	
Note 1:	For random precoder selection, the precoder shall be updated in each TTI (1 ms granularity).			
Note 2:	If the UE reports in an available uplink reporting instance at subframe SF#n based on PMI estimation at a downlink SF not later than SF#(n-4), this reported PMI cannot be applied at the eNB downlink before SF#(n+4).			
Note 3:	To avoid collisions between CQI/PMI reports and HARQ-ACK it is necessary to report both on PUSCH instead of PUCCH.			
Note 4:	PDSCH_RA= 0 dB, PDSCH_RB= 0 dB in order to have the same PDSCH and OCNG power per subcarrier at the receiver.			

**Table 9.4.1.4.3-2 Minimum requirement (FDD)**

Parameter	Test 1	Test 1a
$\gamma$	1.1	[1.1]
UE Category	$\geq 2$	$\geq 2$
Note1:	For UE that indicates support of density reduction for Class B, test 1a will be run and test 1 will be skipped. Otherwise, test 1 will be run and test 1a will be skipped.	

**9.4.1.4.4 TDD (with Class B alternative codebook for one CSI-RS resource configured)**

For the parameters specified in Table 9.4.1.4.4-1, and using the downlink physical channels specified in Annex C.3.2, the minimum requirements are specified in Table 9.4.1.4.4-2.

**Table 9.4.1.4.4-1 PMI test for single-layer (TDD)**



Parameter	Unit	Test 1	Test 1a	
Bandwidth	MHz	10	10	
Transmission mode		9	9	
Uplink downlink configuration		1	1	
Special subframe configuration		4	4	
Propagation channel		EPA5	EPA5	
Precoding granularity	PRB	50	50	
Correlation and antenna configuration		ULA Low 8 x 2	ULA Low 8 x 2	
Beamforming model		Annex B.4.3	Annex B.4.3	
Cell-specific reference signals		Antenna ports 0,1	Antenna ports 0,1	
CSI reference signals		Antenna ports 15,...,22	Antenna ports 15,...,22	
FrequencyDensityBeamformed		1	1/2	
NZP-TransmissionCombBeamformed		N/A	0	
CSI-RS periodicity and subframe offset $T_{\text{CSI-RS}} / \Delta_{\text{CSI-RS}}$		5/ 4	5/ 4	
CSI-RS reference signal configuration		0	0	
eMIMO-Type		Class B	Class B	
alternativeCodebookEnabled CLASSB_K1		TRUE	TRUE	
codebookSubsetRestriction-3		0x 000 0000 0000 FFFF	0x 000 0000 0000 FFFF	
Downlink power allocation	$\rho_A$	dB	0	0
	$\rho_B$	dB	0	0
	$P_c$	dB	-3	-3
	$\sigma$	dB	-3	-3
$N_{oc}^{(j)}$	dB[mW/15kHz]	-98	-98	
Reporting mode		PUCCH 1-1	PUCCH 1-1	
Reporting interval	ms	5	5	
PMI delay (Note 2)	ms	10	10	
Physical channel for CQI/PMI reporting		PUSCH (Note 3)	PUSCH (Note 3)	
PUCCH Report Type for CQI/PMI		2	2	
Physical channel for RI reporting		PUSCH	PUSCH	
PUCCH Report Type for RI		3	3	
<i>cqi-pmi-ConfigurationIndex</i>		4	4	
<i>ri-ConfigIndex</i>		805	805	
Measurement channel		R.45 TDD	R.45A TDD	
Rank number of PDSCH		1	1	
OCNG Pattern		OP.1 TDD	OP.1 TDD	
Max number of HARQ transmissions		4	4	
Redundancy version coding sequence		{0,1,2,3}	{0,1,2,3}	
ACK/NACK feedback mode		Multiplexing	Multiplexing	
Note 1:	For random precoder selection, the precoder shall be updated in each TTI (1 ms granularity).			
Note 2:	If the UE reports in an available uplink reporting instance at subframe SF#n based on PMI estimation at a downlink SF not later than SF#(n-4), this reported PMI cannot be applied at the eNB downlink before SF#(n+4).			
Note 3:	To avoid collisions between CQI/PMI reports and HARQ-ACK it is necessary to report both on PUSCH instead of PUCCH.			
Note 4:	PDCCH DCI format 0 with a trigger for aperiodic CQI shall be transmitted in downlink SF#4 and #9 to allow aperiodic CQI/PMI/RI to be transmitted on uplink SF#3 and #8.			

**Table 9.4.1.4.4-2 Minimum requirement (TDD)**

Parameter	Test 1	Test 1a
$\gamma$	1.2	[1.2]
UE Category	$\geq 2$	$\geq 2$
Note1:	For UE that indicates support of density reduction for Class B, test 1a will be run and test 1 will be skipped. Otherwise, test 1 will be run and test 1a will be skipped.	

#### 9.4.1a Void

##### 9.4.1a.1 Void

##### 9.4.1a.1.1 Void

##### 9.4.1a.1.2 Void

#### 9.4.2 Multiple PMI

##### 9.4.2.1 Minimum requirement PUSCH 1-2 (Cell-Specific Reference Symbols)

##### 9.4.2.1.1 FDD

For the parameters specified in Table 9.4.2.1.1-1, and using the downlink physical channels specified in Annex C.3.2, the minimum requirements are specified in 9.4.2.1.1-2.

**Table 9.4.2.1.1-1: PMI test for single-layer (FDD)**

Parameter	Unit	Test 1	
Bandwidth	MHz	10	
Transmission mode		6	
Propagation channel		EPA5	
Precoding granularity (only for reporting and following PMI)	PRB	6	
Correlation and antenna configuration		Low 2 x 2	
Downlink power allocation	$\rho_A$	dB	-3
	$\rho_B$	dB	-3
	$\sigma$	dB	0
$N_{oc}^{(j)}$	dB[mW/15kHz]	-98	
Reporting mode		PUSCH 1-2	
Reporting interval	ms	1	
PMI delay	ms	8	
Measurement channel		R.11-3 FDD for UE Category 1, R.11 FDD for UE Category $\geq 2$	
OCNG Pattern		OP.1/2 FDD	
Max number of HARQ transmissions		4	
Redundancy version coding sequence		{0,1,2,3}	
<p>Note 1: For random precoder selection, the precoders shall be updated in each TTI (1 ms granularity).</p> <p>Note 2: If the UE reports in an available uplink reporting instance at subframe SF#n based on PMI estimation at a downlink SF not later than SF#(n-4), this reported PMI cannot be applied at the eNB downlink before SF#(n+4).</p> <p>Note 3: One/two sided dynamic OCNG Pattern OP.1/2 FDD as described in Annex A.5.1.1/2 shall be used.</p>			

**Table 9.4.2.1.1-2: Minimum requirement (FDD)**

Parameter	Test 1
$\gamma$	1.2
UE Category	$\geq 1$

#### 9.4.2.1.2 TDD

For the parameters specified in Table 9.4.2.1.2-1, and using the downlink physical channels specified in Annex C.3.2, the minimum requirements are specified in 9.4.2.1.2-2.

Table 9.4.2.1.2-1: PMI test for single-layer (TDD)

Parameter	Unit	Test 1	
Bandwidth	MHz	10	
Transmission mode		6	
Uplink downlink configuration		1	
Special subframe configuration		4	
Propagation channel		EPA5	
Precoding granularity (only for reporting and following PMI)	PRB	6	
Correlation and antenna configuration		Low 2 x 2	
Downlink power allocation	$\rho_A$	dB	-3
	$\rho_B$	dB	-3
	$\sigma$	dB	0
$N_{oc}^{(j)}$	dB[mW/15kHz]	-98	
Reporting mode		PUSCH 1-2	
Reporting interval	ms	1	
PMI delay	ms	10 or 11	
Measurement channel		R.11-3 TDD for UE Category 1 R.11 TDD for UE Category $\geq 2$	
OCNG Pattern		OP.1/2 TDD	
Max number of HARQ transmissions		4	
Redundancy version coding sequence		{0,1,2,3}	
ACK/NACK feedback mode		Multiplexing	
Note 1: For random precoder selection, the precoders shall be updated in each available downlink transmission instance.			
Note 2: If the UE reports in an available uplink reporting instance at subframe SF#n based on PMI estimation at a downlink SF not later than SF#(n-4), this reported PMI cannot be applied at the eNB downlink before SF#(n+4).			
Note 3: One/two sided dynamic OCNG Pattern OP.1/2 TDD as described in Annex A.5.2.1/2 shall be used.			

Table 9.4.2.1.2-2: Minimum requirement (TDD)

Parameter	Test 1
$\gamma$	1.2
UE Category	$\geq 1$

## 9.4.2.2 Minimum requirement PUSCH 2-2 (Cell-Specific Reference Symbols)

## 9.4.2.2.1 FDD

For the parameters specified in Table 9.4.2.1-1, and using the downlink physical channels specified in Annex C.3.2, the minimum requirements are specified in Table 9.4.2.2.1-2.

**Table 9.4.2.2.1-1: PMI test for single-layer (FDD)**

Parameter	Unit	Test 1	
Bandwidth	MHz	10	
Transmission mode		6	
Propagation channel		EVA5	
Correlation and antenna configuration		Low 4 x 2	
Downlink power allocation	$\rho_A$	dB	-6
	$\rho_B$	dB	-6
	$\sigma$	dB	3
$N_{oc}^{(j)}$	dB[mW/15kHz]	-98	
PMI delay	ms	8	
Reporting mode		PUSCH 2-2	
Reporting interval	ms	1	
Measurement channel		R.14-2 FDD	
OCNG Pattern		OP.1/2 FDD	
Subband size ( $k$ )	RBs	3 (full size)	
Number of preferred subbands ( $M$ )		5	
Max number of HARQ transmissions		4	
Redundancy version coding sequence		{0,1,2,3}	
Note 1: For random precoder selection, the precoder shall be updated in each TTI (1 ms granularity) Note 2: If the UE reports in an available uplink reporting instance at subframe SF# $n$ based on PMI estimation at a downlink SF not later than SF#(n-4), this reported PMI cannot be applied at the eNB downlink before SF#(n+4)			

**Table 9.4.2.2.1-2: Minimum requirement (FDD)**

	Test 1
$\gamma$	1.2
UE Category	$\geq 1$

#### 9.4.2.2.2 TDD

For the parameters specified in Table 9.4.2.2.1, and using the downlink physical channels specified in Annex C.3.2, the minimum requirements are specified in Table 9.4.2.2.2-2.

Table 9.4.2.2.2-1: PMI test for single-layer (TDD)

Parameter	Unit	Test 1	
Bandwidth	MHz	10	
Transmission mode		6	
Uplink downlink configuration		1	
Special subframe configuration		4	
Propagation channel		EVA5	
Correlation and antenna configuration		Low 4 x 2	
Downlink power allocation	$\rho_A$	dB	-6
	$\rho_B$	dB	-6
	$\sigma$	dB	3
$N_{oc}^{(j)}$	dB[mW/15kHz]	-98	
PMI delay	ms	10	
Reporting mode		PUSCH 2-2	
Reporting interval	ms	1	
Measurement channel		R.14-2 TDD	
OCNG Pattern		OP.1/2 TDD	
Subband size ( $k$ )	RBs	3 (full size)	
Number of preferred subbands ( $M$ )		5	
Max number of HARQ transmissions		4	
Redundancy version coding sequence		{0,1,2,3}	
ACK/NACK feedback mode		Multiplexing	
Note 1: For random precoder selection, the precoders shall be updated in each available downlink transmission instance. Note 2: If the UE reports in an available uplink reporting instance at subframe SF#n based on PMI estimation at a downlink SF not later than SF#(n-4), this reported PMI cannot be applied at the eNB downlink before SF#(n+4).			

Table 9.4.2.2.2-2 Minimum requirement (TDD)

	Test 1
$\gamma$	1.15
UE Category	$\geq 1$

### 9.4.2.3 Minimum requirement PUSCH 1-2 (CSI Reference Symbol)

#### 9.4.2.3.1 FDD

For the parameters specified in Table 9.4.2.3.1-1, and using the downlink physical channels specified in Annex C.3.2, the minimum requirements are specified in 9.4.2.3.1-2.

Table 9.4.2.3.1-1: PMI test for single-layer (FDD)

Parameter	Unit	Test 1	
Bandwidth	MHz	10	
Transmission mode		9	
Propagation channel		EVA5	
Precoding granularity (only for reporting and following PMI)	PRB	6	
Correlation and antenna configuration		Low ULA 4 x 2	
Cell-specific reference signals		Antenna ports 0,1	
CSI reference signals		Antenna ports 15,....,18	
Beamforming model		Annex B.4.3	
CSI-RS periodicity and subframe offset $T_{\text{CSI-RS}} / \Delta_{\text{CSI-RS}}$		5/ 1	
CSI-RS reference signal configuration		8	
CodeBookSubsetRestriction bitmap		0x0000 0000 0000 FFFF	
Downlink power allocation	$\rho_A$	dB	0
	$\rho_B$	dB	0
	$\rho_C$	dB	-3
	$\sigma$	dB	-3
$N_{oc}^{(j)}$	dB[mW/15kHz]	-98	
Reporting mode		PUSCH 1-2	
Reporting interval	ms	5	
PMI delay	ms	8	
Measurement channel		R.45-1 FDD for UE Category 1, R.45 FDD for UE Category $\geq 2$	
OCNG Pattern		OP.7 FDD for UE Category 1 OP.1 FDD for UE Category $\geq 2$	
Max number of HARQ transmissions		4	
Redundancy version coding sequence		{0,1,2,3}	
Note 1:	For random precoder selection, the precoders shall be updated in each TTI (1 ms granularity).		
Note 2:	If the UE reports in an available uplink reporting instance at subframe SF#n based on PMI estimation at a downlink SF not later than SF#(n-4), this reported PMI cannot be applied at the eNB downlink before SF#(n+4).		
Note 3:	Void.		
Note 4:	PDSCH_RA= 0 dB, PDSCH_RB= 0 dB in order to have the same PDSCH and OCNG power per subcarrier at the receiver.		

**Table 9.4.2.3.1-2: Minimum requirement (FDD)**

Parameter	Test 1
$\gamma$	1.3
UE Category	$\geq 1$

**9.4.2.3.2 TDD**

For the parameters specified in Table 9.4.2.3.2-1, and using the downlink physical channels specified in Annex C.3.2, the minimum requirements are specified in 9.4.2.3.2-2.



**Table 9.4.2.3.2-1: PMI test for single-layer (TDD)**

Parameter	Unit	Test 1	
Bandwidth	MHz	10	
Transmission mode		9	
Uplink downlink configuration		1	
Special subframe configuration		4	
Propagation channel		EVA5	
Precoding granularity (only for reporting and following PMI)	PRB	6	
Antenna configuration		8 x 2	
Correlation modeling		High, Cross polarized	
Cell-specific reference signals		Antenna ports 0,1	
CSI reference signals		Antenna ports 15,...,22	
Beamforming model		Annex B.4.3	
CSI-RS periodicity and subframe offset $T_{\text{CSI-RS}} / \Delta_{\text{CSI-RS}}$		5/4	
CSI-RS reference signal configuration		4	
CodeBookSubsetRestriction bitmap		0x0000 0000 001F FFE0 0000 0000 FFFF	
Downlink power allocation	$\rho_A$	dB	0
	$\rho_B$	dB	0
	$P_C$	db	-6
	$\sigma$	dB	-3
$N_{oc}^{(j)}$	dB[mW/15kHz]	-98	
Reporting mode		PUSCH 1-2	
Reporting interval	ms	5 (Note 4)	
PMI delay	ms	10	
Measurement channel		R.45-1 TDD for UE Category 1, R.45 TDD for UE Category $\geq 2$	
OCNG Pattern		OP.7 TDD for UE Category 1 OP.1 TDD for UE Category $\geq 2$	
Max number of HARQ transmissions		4	
Redundancy version coding sequence		{0,1,2,3}	
ACK/NACK feedback mode		Multiplexing	

Note 1:	For random precoder selection, the precoders shall be updated in each TTI (1 ms granularity).
Note 2:	If the UE reports in an available uplink reporting instance at subframe SF#n based on PMI estimation at a downlink SF not later than SF#(n-4), this reported PMI cannot be applied at the eNB downlink before SF#(n+4).
Note 3:	Void.
Note 4:	PDCCH DCI format 0 with a trigger for aperiodic CQI shall be transmitted in downlink SF#4 and #9 to allow aperiodic CQI/PMI/RI to be transmitted on uplink SF#3 and #8.
Note 5:	Randomization of the principle beam direction shall be used as specified in B.2.3A.4.

**Table 9.4.2.3.2-2: Minimum requirement (TDD)**

Parameter	Test 1
$\gamma$	3.5
UE Category	$\geq 1$

**9.4.2.3.3 FDD (with 4Tx enhanced codebook)**

For the parameters specified in Table 9.4.2.3.3-1, and using the downlink physical channels specified in Annex C.3.2, the minimum requirements are specified in 9.4.2.3.3-2.

Table 9.4.2.3.3-1 PMI test for dual-layer (FDD)

Parameter	Unit	Test 1	
Bandwidth	MHz	10	
Transmission mode		9	
Propagation channel		EVA5	
Precoding granularity (only for reporting and following PMI)	PRB	6	
Correlation and antenna configuration		High XP 4 x 2	
Beamforming model		Annex B.4.3	
Cell-specific reference signals		Antenna ports 0,1	
CSI reference signals		Antenna ports 15,...,18	
CSI-RS periodicity and subframe offset $T_{\text{csi-rs}} / k_{\text{csi-rs}}$		5/ 1	
CSI-RS reference signal configuration		8	
CodeBookSubsetRestriction bitmap		0x0000 0000 FFFF 0000 FFFF 0000	
Downlink power allocation	$\rho_A$	dB	0
	$\rho_B$	dB	0
	$P_c$	dB	-3
	$\sigma$	dB	-3
$N_{oc}^{(j)}$	dB[mW/15kHz]	-98	
Reporting mode		PUSCH1-2	
Reporting interval	ms	5	
PMI delay (Note 2)	ms	8	
Measurement channel		R.45-1 FDD for UE Category 1, R.45 FDD for UE Category $\geq 2$	
Rank Number of PDSCH		2	
OCNG Pattern		OP.7 FDD for UE Category 1 OP.1 FDD for UE Category $\geq 2$	
Max number of HARQ transmissions		4	
Redundancy version coding sequence		{0,1,2,3}	
alternativeCodeBookEnable dFor4TX-r12		True	
Note 1:	For random precoder selection, the precoder shall be updated in each TTI (1 ms granularity)		
Note 2:	If the UE reports in an available uplink reporting instance at subframe SF#n based on PMI estimation at a downlink SF not later than SF#(n-4), this reported PMI cannot be applied at the eNB downlink before SF#(n+4).		
Note 3:	Void.		
Note 4:	PDSCH_RA= 0 dB, PDSCH_RB= 0 dB in order to have the same PDSCH and OCNG power per subcarrier at the receiver.		
Note 5:	Randomization of the principle beam direction shall be used as specified in B.2.3A.4		

**Table 9.4.2.3.3-2 Minimum requirement (FDD)**

Parameter	Test 1
$\gamma$	1.2
UE Category	$\geq 1$

**9.4.2.3.4 TDD (with 4Tx enhanced codebook)**

For the parameters specified in Table 9.4.2.3.4-1, and using the downlink physical channels specified in Annex C.3.2, the minimum requirements are specified in 9.4.2.3.4-2.

Table 9.4.2.3.4-1 PMI test for dual-layer (TDD)

Parameter	Unit	Test 1	
Bandwidth	MHz	10	
Transmission mode		9	
Uplink downlink configuration		1	
Special subframe configuration		4	
Propagation channel		EVA5	
Precoding granularity (only for reporting and following PMI)	PRB	6	
Correlation and antenna configuration		XP High 4 x 2	
Beamforming model		Annex B.4.3	
Cell-specific reference signals		Antenna ports 0,1	
CSI reference signals		Antenna ports 15,...,18	
CSI-RS periodicity and subframe offset $T_{\text{CSI-RS}} / k_{\text{CSI-RS}}$		5/4	
CSI-RS reference signal configuration		4	
CodeBookSubsetRestriction bitmap		0x0000 0000 FFFF 0000 FFFF 0000	
Downlink power allocation	$\rho_A$	dB	0
	$\rho_B$	dB	0
	$P_c$	dB	-3
	$\sigma$	dB	-3
$N_{DC}^{(j)}$	dB[mW/15kHz]	-98	
Reporting mode		PUSCH1-2	
Reporting interval	ms	5	
PMI delay (Note 2)	ms	10	
Measurement channel		R.61-1 TDD for UE Category 1, R.61 TDD for UE Category $\geq 2$	
Rank Number of PDSCH		2	
OCNG Pattern		OP.7 FDD for UE Category 1 OP.1 FDD for UE Category $\geq 2$	
Max number of HARQ transmissions		4	
Redundancy version coding sequence		{0,1,2,3}	
ACK/NACK feedback mode		Multiplexing	
alternativeCodeBookEnable dFor4TX-r12		True	
<p>Note 1: For random precoder selection, the precoder shall be updated in each TTI (1 ms granularity)</p> <p>Note 2: If the UE reports in an available uplink reporting instance at subframe SF#n based on PMI estimation at a downlink SF not later than SF#(n-4), this reported PMI cannot be applied at the eNB downlink before SF#(n+4).</p> <p>Note3: Void.</p> <p>Note 4: PDCCH DCI format 0 with a trigger for aperiodic CQI shall be transmitted in downlink SF#4 and #9 to allow aperiodic CQI/PMI/RI to be transmitted on uplink SF#3 and #8.</p> <p>Note 5: Randomization of the principle beam direction shall be used as specified in B.2.3A.4.</p>			

**Table 9.4.2.3.4-2 Minimum requirement (TDD)**

Parameter	Test 1
$\gamma$	1.2
UE Category	$\geq 1$

**9.4.2.3.5 FDD (with Class A 16Tx codebook)**

For the parameters specified in Table 9.4.2.3.5-1, and using the downlink physical channels specified in Annex C.3.2, the minimum requirements are specified in Table 9.4.2.3.5-2.

**Table 9.4.2.3.5-1: PMI test for dual-layer (FDD)**



Parameter		Unit	Test 1
Bandwidth		MHz	10
Transmission mode			9
Propagation channel			EVA5
Precoding granularity (only for reporting and following PMI)		PRB	6
Correlation and antenna configuration			High 2D XP 16(2,4,2) x 2
Cell-specific reference signals			Antenna ports 0,1
CSI reference signals			Antenna ports 15,...,30
Beamforming model			Annex B.4.3
CDM Type			CDM4
CSI-RS periodicity and subframe offset $T_{\text{CSI-RS}} / \Delta_{\text{CSI-RS}}$			5/ 1
NZP-CSI-RS-Configuration-List			{0,1}
eMIMO-Type			Class A
codebookConfig-N1			2
codebookConfig-N2			4
codebook-Over-Sampling-RateConfig-O1			8
codebook-Over-Sampling-RateConfig-O2			8
Codebook-Config			Note 5
codebookSubsetRestriction-1			0x02 FFFF
codebookSubsetRestriction-2			Codebook-Config 1: 0000 1111 0000 Codebook-Config 2,3,4: 0x 00 000000 FFFF 0000
Downlink power allocation	$\rho_A$	dB	0
	$\rho_B$	dB	0
	$P_c$	dB	-6
	$\sigma$	dB	-3
	$N_{oc}^{(j)}$	dB[mW/15kHz]	-98
Reporting mode			PUSCH 1-2
Reporting interval		ms	5
PMI delay (Note 2)		ms	8
Measurement channel			R.78 FDD
Rank Number of PDSCH			2
OCNG Pattern			OP.1 FDD
Max number of HARQ transmissions			4
Redundancy version coding sequence			{0,1,2,3}

Note 1:	For random precoder selection, the precoder shall be updated in each TTI (1 ms granularity).
Note 2:	If the UE reports in an available uplink reporting instance at subframe SF#n based on PMI estimation at a downlink SF not later than SF#(n-4), this reported PMI cannot be applied at the eNB downlink before SF#(n+4).
Note 3:	PDSCH_RA= 0 dB, PDSCH_RB= 0 dB in order to have the same PDSCH and OCNG power per subcarrier at the receiver.
Note 4:	Randomization of the principle beam direction shall be used as specified in B.2.3B.4.
Note 5:	Value of parameter codebookConfig shall be random selected one value from UE supported codebook configurations.

**Table 9.4.2.3.5-2: Minimum requirement (FDD)**

Parameter	Test 1
$\gamma$	2.5
UE Category	$\geq 2$

#### 9.4.2.3.6 TDD (with Class A 16Tx codebook)

For the parameters specified in Table 9.4.2.3.6-1, and using the downlink physical channels specified in Annex C.3.2, the minimum requirements are specified in Table 9.4.2.3.6-2.

**Table 9.4.2.3.6-1: PMI test for dual-layer (TDD)**

Parameter	Unit	Test 1	
Bandwidth	MHz	10	
Transmission mode		9	
Uplink downlink configuration		1	
Special subframe configuration		4	
Propagation channel		EVA5	
Precoding granularity (only for reporting and following PMI)	PRB	6	
Correlation and antenna configuration		High 2D XP 16(2,4,2) x 2	
Cell-specific reference signals		Antenna ports 0,1	
CSI reference signals		Antenna ports 15,...,26	
Beamforming model		Annex B.4.3	
CDM Type		CDM4	
CSI-RS periodicity and subframe offset $T_{\text{CSI-RS}} / \Delta_{\text{CSI-RS}}$		5/4	
NZP-CSI-RS-Configuration- List		{0,1}	
eMIMO-Type		Class A	
codebookConfig-N1		2	
codebookConfig-N2		4	
codebook-Over-Sampling- RateConfig-O1		8	
codebook-Over-Sampling- RateConfig-O2		8	
Codebook-Config		Note 5	
codebookSubsetRestriction-1		0x02 FFFF	
codebookSubsetRestriction-2		Codebook-Config 1: 0000 1111 0000 Codebook-Config 2,3,4: 0x 00 000000 FFFF 0000	
Downlink power allocation	$\rho_A$	dB	0
	$\rho_B$	dB	0
	$\rho_C$	dB	-6
	$\sigma$	dB	-3
$N_{oc}^{(j)}$	dB[mW/15kHz]	-98	
Reporting mode		PUSCH 1-2	
Reporting interval	ms	5	
PMI delay (Note 2)	ms	10	
Measurement channel		R.78 TDD	
Rank Number of PDSCH		2	
OCNG Pattern		OP.1 TDD	
Max number of HARQ transmissions		4	
Redundancy version coding sequence		{0,1,2,3}	
ACK/NACK feedback mode		Multiplexing	

Note 1:	For random precoder selection, the precoder shall be updated in each TTI (1 ms granularity).
Note 2:	If the UE reports in an available uplink reporting instance at subframe SF#n based on PMI estimation at a downlink SF not later than SF#(n-4), this reported PMI cannot be applied at the eNB downlink before SF#(n+4).
Note 3:	PDCCH DCI format 0 with a trigger for aperiodic CQI shall be transmitted in downlink SF#4 and #9 to allow aperiodic CQI/PMI/RI to be transmitted on uplink SF#3 and #8.
Note 4:	Randomization of the principle beam direction shall be used as specified in B.2.3B.4
Note 5:	Value of parameter codebookConfig shall be random selected one value from UE supported codebook configurations.

**Table 9.4.2.3.6-2: Minimum requirement (TDD)**

Parameter	Test 1
$\gamma$	2.5
UE Category	$\geq 2$

**9.4.2.3.7 FDD (with Class A 32Tx codebook)**

For the parameters specified in Table 9.4.2.3.7-1, and using the downlink physical channels specified in Annex C.3.2, the minimum requirements are specified in Table 9.4.2.3.7-2.

**Table 9.4.2.3.7-1: PMI test for dual-layer (FDD)**

Parameter		Unit	Test 1
Bandwidth		MHz	10
Transmission mode			9
Propagation channel			EVA5
Precoding granularity (only for reporting and following PMI)		PRB	6
Correlation and antenna configuration			High 2D XP 32(4,4,2) x 2
Cell-specific reference signals			Antenna ports 0,1
CSI reference signals			Antenna ports 15,...,46
Beamforming model			Annex B.4.3
CDM Type			CDM8
CSI-RS periodicity and subframe offset $T_{\text{CSI-RS}} / \Delta_{\text{CSI-RS}}$			5/ 1
FrequencyDensityNonPrecoded			1
NWP- TransmissionCombListNonprecoded			NA
NWP-CSI-RS-Configuration-List			{0,1,2,3}
eMIMO-Type			Class A
codebookConfig-N1			4
codebookConfig-N2			4
codebook-Over-Sampling- RateConfig-O1			8
codebook-Over-Sampling- RateConfig-O2			4
Codebook-Config			Note 5
codebookSubsetRestriction-1			0x02 FFFF
codebookSubsetRestriction-2			Codebook-Config 1: 0000 1111 0000 Codebook-Config 2,3,4: 0x 00 0000 FFFF 0000
Downlink power allocation	$\rho_A$	dB	0
	$\rho_B$	dB	0
	$\rho_C$	dB	-6
	$\sigma$	dB	-3
	$N_{oc}^{(j)}$	dB[mW/15 kHz]	-98
Reporting mode			PUSCH 1-2
Reporting interval		ms	5
PMI delay (Note 2)		ms	8
Measurement channel			R.89 FDD
Rank Number of PDSCH			2
OCNG Pattern			OP.1 FDD
Max number of HARQ transmissions			4
Redundancy version coding sequence			{0,1,2,3}

Note 1:	For random precoder selection, the precoder shall be updated in each TTI (1 ms granularity).
Note 2:	If the UE reports in an available uplink reporting instance at subframe SF#n based on PMI estimation at a downlink SF not later than SF#(n-4), this reported PMI cannot be applied at the eNB downlink before SF#(n+4).
Note 3:	PDSCH_RA= 0 dB, PDSCH_RB= 0 dB in order to have the same PDSCH and OCNG power per subcarrier at the receiver.
Note 4:	Randomization of the principle beam direction shall be used as specified in B.2.3B.4.
Note 5:	Value of parameter codebookConfig shall be random selected one value from UE supported codebook configurations.

**Table 9.4.2.3.7-2: Minimum requirement (FDD)**

Parameter	Test 1
$\gamma$	[4,5]
UE Category	$\geq 2$

**9.4.2.3.8 TDD (with Class A 32Tx codebook)**

For the parameters specified in Table 9.4.2.3.8-1, and using the downlink physical channels specified in Annex C.3.2, the minimum requirements are specified in Table 9.4.2.3.8-2.



**Table 9.4.2.3.8-1: PMI test for dual-layer (TDD)**

Parameter	Unit	Test 1	
Bandwidth	MHz	10	
Transmission mode		9	
Uplink downlink configuration		1	
Special subframe configuration		4	
Propagation channel		EVA5	
Precoding granularity (only for reporting and following PMI)	PRB	6	
Correlation and antenna configuration		High 2D XP 32(4,4,2) x 2	
Cell-specific reference signals		Antenna ports 0,1	
CSI reference signals		Antenna ports 15,...,46	
Beamforming model		Annex B.4.3	
CDM Type		CDM8	
CSI-RS periodicity and subframe offset $T_{\text{CSI-RS}} / \Delta_{\text{CSI-RS}}$		5/4	
FrequencyDensityNonPrecoded		1	
NZP- TransmissionCombListNonprecoded		NA	
NZP-CSI-RS-Configuration-List		{0,1,2,3}	
eMIMO-Type		Class A	
codebookConfig-N1		4	
codebookConfig-N2		4	
codebook-Over-Sampling- RateConfig-O1		8	
codebook-Over-Sampling- RateConfig-O2		8	
Codebook-Config		Note 5	
codebookSubsetRestriction-1		0x02 FFFF	
codebookSubsetRestriction-2		Codebook-Config 1: 0000 1111 0000 Codebook-Config 2,3,4: 0x 00 0000 FFFF 0000	
Downlink power allocation	$\rho_A$	dB	0
	$\rho_B$	dB	0
	$\rho_C$	dB	-6
	$\sigma$	dB	-3
$N_{oc}^{(j)}$	dB[mW/1 5kHz]	-98	
Reporting mode		PUSCH 1-2	
Reporting interval	ms	5	
PMI delay (Note 2)	ms	10	
Measurement channel		R.89 TDD	
Rank Number of PDSCH		2	
OCNG Pattern		OP.1 TDD	
Max number of HARQ transmissions		4	
Redundancy version coding sequence		{0,1,2,3}	
ACK/NACK feedback mode		Multiplexing	

Note 1:	For random precoder selection, the precoder shall be updated in each TTI (1 ms granularity).
Note 2:	If the UE reports in an available uplink reporting instance at subframe SF#n based on PMI estimation at a downlink SF not later than SF#(n-4), this reported PMI cannot be applied at the eNB downlink before SF#(n+4).
Note 3:	PDCCH DCI format 0 with a trigger for aperiodic CQI shall be transmitted in downlink SF#4 and #9 to allow aperiodic CQI/PMI/RI to be transmitted on uplink SF#3 and #8.
Note 4:	Randomization of the principle beam direction shall be used as specified in B.2.3B.4
Note 5:	Value of parameter codebookConfig shall be random selected one value from UE supported codebook configurations.

**Table 9.4.2.3.8-2: Minimum requirement (TDD)**

Parameter	Test 1
$\gamma$	[4.5]
UE Category	$\geq 2$

#### 9.4.2.3.9 FDD (with Class A 16Tx advanced codebook)

For the parameters specified in Table 9.4.2.3.9-1, and using the downlink physical channels specified in Annex C.3.2, the minimum requirements are specified in Table 9.4.2.3.9-2.

**Table 9.4.2.3.9-1: PMI test for dual-layer (FDD)**

Parameter	Unit	Test 1	
Bandwidth	MHz	10	
Transmission mode		9	
Propagation channel		EVA5	
Precoding granularity (only for reporting and following PMI)	PRB	6	
Correlation and antenna configuration		Medium 2D XP 16(2,4,2) x 2	
Cell-specific reference signals		Antenna ports 0,1	
CSI reference signals		Antenna ports 15,...,30	
Beamforming model		Annex B.4.3	
CDM Type		CDM4	
CSI-RS periodicity and subframe offset $T_{\text{CSI-RS}} / \Delta_{\text{CSI-RS}}$		5/ 1	
NZP-CSI-RS-Configuration-List		{0,1}	
eMIMO-Type		Class A	
<i>advancedCodebookEnabled</i>		TRUE	
<i>codebookConfig-N1</i>		2	
<i>codebookConfig-N2</i>		4	
<i>codebook-Over-Sampling-RateConfig-O1</i>		8	
<i>codebook-Over-Sampling-RateConfig-O2</i>		8	
<i>Codebook-Config</i>		Note 5	
<i>codebookSubsetRestriction-1</i>		0x02 FFFF	
<i>codebookSubsetRestriction-2</i>		Codebook-Config 1: 0000 1111 0000 Codebook-Config 2,3,4: 0x 00 000000 FFFF 0000	
Downlink power allocation	$\rho_A$	dB	0
	$\rho_B$	dB	0
	$P_c$	dB	-6
	$\sigma$	dB	-3
$N_{oc}^{(j)}$		dB[mW/15kHz]	-98
Reporting mode			PUSCH 1-2
Reporting interval	ms		5
PMI delay (Note 2)	ms		8
Measurement channel			R.78 FDD
Rank Number of PDSCH			2
OCNG Pattern			OP.1 FDD
Max number of HARQ transmissions			4
Redundancy version coding sequence			{0,1,2,3}

Note 1:	For random precoder selection, the precoder shall be updated in each TTI (1 ms granularity).
Note 2:	If the UE reports in an available uplink reporting instance at subframe SF#n based on PMI estimation at a downlink SF not later than SF#(n-4), this reported PMI cannot be applied at the eNB downlink before SF#(n+4).
Note 3:	PDSCH_RA= 0 dB, PDSCH_RB= 0 dB in order to have the same PDSCH and OCNG power per subcarrier at the receiver.
Note 4:	Randomization of the dual-cluster beam directions shall be used as specified in B.2.3B.4A. The value of relative power ratio (p) shall be fixed as 1 during the test.
Note 5:	Value of parameter codebookConfig shall be random selected one value from UE supported codebook configurations.

**Table 9.4.2.3.9-2: Minimum requirement (FDD)**

Parameter	Test 1
$\gamma$	[1.03]
UE Category	$\geq 2$

#### 9.4.2.3.10 TDD (with Class A 16Tx advanced codebook)

For the parameters specified in Table 9.4.2.3.10-1, and using the downlink physical channels specified in Annex C.3.2, the minimum requirements are specified in Table 9.4.2.3.10-2.

**Table 9.4.2.3.10-1: PMI test for dual-layer (TDD)**

Parameter	Unit	Test 1	
Bandwidth	MHz	10	
Transmission mode		9	
Uplink downlink configuration		1	
Special subframe configuration		4	
Propagation channel		EVA5	
Precoding granularity (only for reporting and following PMI)	PRB	6	
Correlation and antenna configuration		Medium 2D XP 16(2,4,2) x 2	
Cell-specific reference signals		Antenna ports 0,1	
CSI reference signals		Antenna ports 15,...,26	
Beamforming model		Annex B.4.3	
CDM Type		CDM4	
CSI-RS periodicity and subframe offset $T_{CSI-RS} / \Delta_{CSI-RS}$		5/ 4	
NZP-CSI-RS-Configuration- List		{0,1}	
eMIMO-Type		Class A	
<i>advancedCodebookEnabled</i>		TRUE	
codebookConfig-N1		2	
codebookConfig-N2		4	
codebook-Over-Sampling- RateConfig-O1		8	
codebook-Over-Sampling- RateConfig-O2		8	
Codebook-Config		Note 5	
codebookSubsetRestriction-1		0x02 FFFF	
codebookSubsetRestriction-2		Codebook-Config 1: 0000 1111 0000 Codebook-Config 2,3,4: 0x 00 000000 FFFF 0000	
Downlink power allocation	$\rho_A$	dB	0
	$\rho_B$	dB	0
	$\rho_C$	dB	-6
	$\sigma$	dB	-3
$N_{oc}^{(j)}$	dB[mW/15kHz]	-98	
Reporting mode		PUSCH 1-2	
Reporting interval	ms	5	
PMI delay (Note 2)	ms	10	
Measurement channel		R.78 TDD	
Rank Number of PDSCH		2	
OCNG Pattern		OP.1 TDD	
Max number of HARQ transmissions		4	
Redundancy version coding sequence		{0,1,2,3}	
ACK/NACK feedback mode		Multiplexing	



Note 1:	For random precoder selection, the precoder shall be updated in each TTI (1 ms granularity).
Note 2:	If the UE reports in an available uplink reporting instance at subframe SF#n based on PMI estimation at a downlink SF not later than SF#(n-4), this reported PMI cannot be applied at the eNB downlink before SF#(n+4).
Note 3:	PDCCH DCI format 0 with a trigger for aperiodic CQI shall be transmitted in downlink SF#4 and #9 to allow aperiodic CQI/PMI/RI to be transmitted on uplink SF#3 and #8.
Note 4:	Randomization of the dual-cluster beam directions shall be used as specified in B.2.3B.4A. The value of relative power ratio ( $\rho$ ) shall be fixed as 1 during the test.
Note 5:	Value of parameter codebookConfig shall be random selected one value from UE supported codebook configurations.

**Table 9.4.2.3.10-2: Minimum requirement (TDD)**

Parameter	Test 1
$\gamma$	[1..03]
UE Category	$\geq 2$

### 9.4.3 Void

## 9.5 Reporting of Rank Indicator (RI)

The purpose of this test is to verify that the reported rank indicator accurately represents the channel rank. The accuracy of RI (CQI) reporting is determined by the relative increase of the throughput obtained when transmitting based on the reported rank compared to the case for which a fixed rank is used for transmission. Transmission mode 4 is used with the specified CodebookSubSetRestriction in section 9.5.1, transmission mode 9 is used with the specified CodebookSubSetRestriction in section 9.5.2 and transmission mode 3 is used with the specified CodebookSubSetRestriction in section 9.5.3, and transmission mode 10 is used with the specified CodebookSubSetRestriction in section 9.5.5.

For fixed rank 1 transmission in sections 9.5.1, 9.5.2 and 9.5.5, the RI and PMI reporting is restricted to two single-layer precoders, For fixed rank 2 transmission in sections 9.5.1, 9.5.2 and 9.5.5, the RI and PMI reporting is restricted to one two-layer precoder. For follow RI transmission in sections 9.5.1 and 9.5.2, the RI and PMI reporting is restricted to select the union of these precoders. Channels with low and high correlation are used to ensure that RI reporting reflects the channel condition.

For fixed rank 1 transmission in section 9.5.3, the RI reporting is restricted to single-layer, for fixed rank 2 transmission in section 9.5.3, the RI reporting is restricted to two-layers. For follow RI transmission in section 9.5.3, the RI reporting is either one or two layers.

### 9.5.1 Minimum requirement (Cell-Specific Reference Symbols)

#### 9.5.1.1 FDD

The minimum performance requirement in Table 9.5.1.1-2 is defined as

- The ratio of the throughput obtained when transmitting based on UE reported RI and that obtained when transmitting with fixed rank 1 shall be  $\geq \gamma_1$ ;
- The ratio of the throughput obtained when transmitting based on UE reported RI and that obtained when transmitting with fixed rank 2 shall be  $\geq \gamma_2$ ;

For the parameters specified in Table 9.5.1.1-1, and using the downlink physical channels specified in Annex C.3.2, the minimum requirements are specified in Table 9.5.1.1-2.

Table 9.5.1.1-1: RI Test (FDD)

Parameter	Unit	Test 1	Test 2	Test 3
Bandwidth	MHz		10	
PDSCH transmission mode			4	
Downlink power allocation	$\rho_A$	dB		-3
	$\rho_B$	dB		-3
	$\sigma$	dB		0
Propagation condition and antenna configuration		2 x 2 EPA5		
CodeBookSubsetRestriction bitmap		000011 for fixed RI = 1 010000 for fixed RI = 2 010011 for UE reported RI		
Antenna correlation		Low	Low	High
RI configuration		Fixed RI=2 and follow RI	Fixed RI=1 and follow RI	Fixed RI=1 and follow RI
SNR	dB	0	20	20
$N_{oc}^{(j)}$	dB[mW/15kHz]	-98	-98	-98
$\hat{I}_{or}^{(j)}$	dB[mW/15kHz]	-98	-78	-78
Maximum number of HARQ transmissions		1		
Reporting mode		PUCCH 1-1 (Note 4)		
Physical channel for CQI/PMI reporting		PUCCH Format 2		
PUCCH Report Type for CQI/PMI		2		
Physical channel for RI reporting		PUSCH (Note 3)		
PUCCH Report Type for RI		3		
Reporting periodicity	ms	$N_{pd}=5$		
PMI and CQI delay	ms	8		
<i>cqi-pmi-ConfigurationIndex</i>		6		
<i>ri-ConfigurationInd</i>		1 (Note 5)		
<p>Note 1: If the UE reports in an available uplink reporting instance at subframe SF#n based on PMI and CQI estimation at a downlink subframe not later than SF#(n-4), this reported PMI and wideband CQI cannot be applied at the eNB downlink before SF#(n+4).</p> <p>Note 2: Reference measurement channel RC.2 FDD according to Table A.4-1 with one sided dynamic OCNG Pattern OP.1 FDD as described in Annex A.5.1.1.</p> <p>Note 3: To avoid collisions between RI reports and HARQ-ACK it is necessary to report both on PUSCH instead of PUCCH. PDCCH DCI format 0 shall be transmitted in downlink SF#4 and #9 to allow periodic RI to multiplex with the HARQ-ACK on PUSCH in uplink subframe SF#8 and #3.</p> <p>Note 4: The bit field for precoding information in DCI format 2 shall be mapped as:  <ul style="list-style-type: none"> <li>• For reported RI = 1 and PMI = 0 &gt;&gt; precoding information bit field index = 1</li> <li>• For reported RI = 1 and PMI = 1 &gt;&gt; precoding information bit field index = 2</li> <li>• For reported RI = 2 and PMI = 0 &gt;&gt; precoding information bit field index = 0</li> </ul> </p> <p>Note 5: To avoid the ambiguity of TE behaviour when applying CQI and PMI during rank switching, RI reports are to be applied at the TE with one subframe delay in addition to Note 1 to align with CQI and PMI reports.</p>				

Table 9.5.1.1-2: Minimum requirement (FDD)

	Test 1	Test 2	Test 3
$\gamma_1$	N/A	1.05	0.9
$\gamma_2$	1	N/A	N/A
UE Category	$\geq 2$	$\geq 2$	$\geq 2$

## 9.5.1.2 TDD

The minimum performance requirement in Table 9.5.1.2-2 is defined as

- a) The ratio of the throughput obtained when transmitting based on UE reported RI and that obtained when transmitting with fixed rank 1 shall be  $\geq \gamma_1$ ;
- b) The ratio of the throughput obtained when transmitting based on UE reported RI and that obtained when transmitting with fixed rank 2 shall be  $\geq \gamma_2$ ;

For the parameters specified in Table 9.5.1.2-1, and using the downlink physical channels specified in Annex C.3.2, the minimum requirements are specified in Table 9.5.1.2-2.

**Table 9.5.1.2-1: RI Test (TDD)**

Parameter	Unit	Test 1	Test 2	Test 3
Bandwidth	MHz		10	
PDSCH transmission mode			4	
Downlink power allocation	$\rho_A$	dB	-3	
	$\rho_B$	dB	-3	
	$\sigma$	dB	0	
Uplink downlink configuration			2	
Special subframe configuration			4	
Propagation condition and antenna configuration			2 x 2 EPA5	
CodeBookSubsetRestriction bitmap			000011 for fixed RI = 1 010000 for fixed RI = 2 010011 for UE reported RI	
Antenna correlation		Low	Low	High
RI configuration		Fixed RI=2 and follow RI	Fixed RI=1 and follow RI	Fixed RI=1 and follow RI
SNR	dB	0	20	20
$N_{oc}^{(j)}$	dB[mW/15kHz]	-98	-98	-98
$\hat{I}_{or}^{(j)}$	dB[mW/15kHz]	-98	-78	-78
Maximum number of HARQ transmissions			1	
Reporting mode			PUSCH 3-1 (Note 3)	
Reporting interval	ms		5	
PMI and CQI delay	ms		10 or 11	
ACK/NACK feedback mode			Bundling	
Note 1:	If the UE reports in an available uplink reporting instance at subframe SF#n based on PMI and CQI estimation at a downlink subframe not later than SF#(n-4), this reported PMI and wideband CQI cannot be applied at the eNB downlink before SF#(n+4).			
Note 2:	Reference measurement channel RC.2 TDD according to Table A.4-1 with one sided dynamic OCNG Pattern OP.1 TDD as described in Annex A.5.2.1.			
Note 3:	Reported wideband CQI and PMI are used and sub-band CQI is discarded.			

**Table 9.5.1.2-2: Minimum requirement (TDD)**

	Test 1	Test 2	Test 3
$\gamma_1$	N/A	1.05	0.9
$\gamma_2$	1	N/A	N/A
UE Category	$\geq 2$	$\geq 2$	$\geq 2$

## 9.5.2 Minimum requirement (CSI Reference Symbols)

### 9.5.2.1 FDD

The minimum performance requirement in Table 9.5.2.1-2 is defined as

- a) The ratio of the throughput obtained when transmitting based on UE reported RI and that obtained when transmitting with fixed rank 1 shall be  $\geq \gamma_1$ ;

b) The ratio of the throughput obtained when transmitting based on UE reported RI and that obtained when transmitting with fixed rank 2 shall be  $\geq \gamma_2$ ;

For the parameters specified in Table 9.5.2.1-1, and using the downlink physical channels specified in Annex C.3.2, the minimum requirements are specified in Table 9.5.2.1-2.

**Table 9.5.2.1-1: RI Test (FDD)**

Parameter	Unit	Test 1	Test 2	Test 3
Bandwidth	MHz		10	
PDSCH transmission mode			9	
Downlink power allocation	$\rho_A$	dB	0	
	$\rho_B$	dB	0	
	$\rho_C$	dB	0	
	$\sigma$	dB	0	
Propagation condition and antenna configuration		2 x 2 EPA5		
Cell-specific reference signals		Antenna ports 0		
Beamforming Model		As specified in Section B.4.3		
CSI reference signals		Antenna ports 15, 16		
CSI-RS periodicity and subframe offset $T_{CSI-RS} / \Delta_{CSI-RS}$		5/1		
CSI reference signal configuration		6		
CodeBookSubsetRestriction bitmap		000011 for fixed RI = 1 010000 for fixed RI = 2 010011 for UE reported RI		
Antenna correlation		Low	Low	High
RI configuration		Fixed RI=2 and follow RI	Fixed RI=1 and follow RI	Fixed RI=1 and follow RI
SNR	dB	0	20	20
$N_{oc}^{(j)}$	dB[mW/15kHz]	-98	-98	-98
$\hat{I}_{or}^{(j)}$	dB[mW/15kHz]	-98	-78	-78
Maximum number of HARQ transmissions		1		
Reporting mode		PUCCH 1-1		
Physical channel for CQI/PMI reporting		PUSCH (Note 3)		
PUCCH Report Type for CQI/PMI		2		
Physical channel for RI reporting		PUCCH Format 2		
PUCCH Report Type for RI		3		
Reporting periodicity	ms	$N_{pd} = 5$		
PMI and CQI delay	ms	8		
<i>cqi-pmi-ConfigurationIndex</i>		2		
<i>n-ConfigurationInd</i>		1 (Note 4)		
Note 1:	If the UE reports in an available uplink reporting instance at subframe SF#n based on PMI and CQI estimation at a downlink subframe not later than SF#(n-4), this reported PMI and wideband CQI cannot be applied at the eNB downlink before SF#(n+4).			
Note 2:	Reference measurement channel RC.9 FDD according to Table A.4-1 with one sided dynamic OCNG Pattern OP.1 FDD as described in Annex A.5.1.1.			
Note 3:	To avoid collisions between CQI/ PMI reports and HARQ-ACK it is necessary to report both on PUSCH instead of PUCCH. PDCCH DCI format 0 shall be transmitted in downlink SF#1 and #6 to allow periodic CQI/ PMI to multiplex with the HARQ-ACK on PUSCH in uplink SF#0 and #5.			
Note 4:	To avoid the ambiguity of TE behaviour when applying CQI and PMI during rank switching, RI reports are to be applied at the TE with one subframe delay in addition to Note 1 to align with CQI and PMI reports.			

**Table 9.5.2.1-2: Minimum requirement (FDD)**

	<b>Test 1</b>	<b>Test 2</b>	<b>Test 3</b>
$\gamma_1$	N/A	1.05	0.9
$\gamma_2$	1	N/A	N/A
UE Category	$\geq 2$	$\geq 2$	$\geq 2$

### 9.5.2.2 TDD

The minimum performance requirement in Table 9.5.2.2-2 is defined as

- a) The ratio of the throughput obtained when transmitting based on UE reported RI and that obtained when transmitting with fixed rank 1 shall be  $\geq \gamma_1$ ;
- b) The ratio of the throughput obtained when transmitting based on UE reported RI and that obtained when transmitting with fixed rank 2 shall be  $\geq \gamma_2$ ;

For the parameters specified in Table 9.5.2.2-1, and using the downlink physical channels specified in Annex C.3.2, the minimum requirements are specified in Table 9.5.2.2-2.

Table 9.5.2.2-1: RI Test (TDD)

Parameter	Unit	Test 1	Test 2	Test 3
Bandwidth	MHz		10	
PDSCH transmission mode			9	
Downlink power allocation	$\rho_A$	dB	0	
	$\rho_B$	dB	0	
	$\rho_C$	dB	0	
	$\sigma$	dB	0	
Uplink downlink configuration			1	
Special subframe configuration			4	
Propagation condition and antenna configuration			2 x 2 EPA5	
Cell-specific reference signals			Antenna ports 0	
CSI reference signals			Antenna ports 15, 16	
Beamforming Model			As specified in Section B.4.3	
CSI reference signal configuration			4	
CSI-RS periodicity and subframe offset $T_{\text{CSI-RS}} / \Delta_{\text{CSI-RS}}$			5/4	
CodeBookSubsetRestriction bitmap			000011 for fixed RI = 1 010000 for fixed RI = 2 010011 for UE reported RI	
Antenna correlation		Low	Low	High
RI configuration		Fixed RI=2 and follow RI	Fixed RI=1 and follow RI	Fixed RI=1 and follow RI
SNR	dB	0	20	20
$N_{oc}^{(j)}$	dB[mW/15kHz]	-98	-98	-98
$\hat{I}_{or}^{(j)}$	dB[mW/15kHz]	-98	-78	-78
Maximum number of HARQ transmissions			1	
Reporting mode			PUCCH 1-1	
Physical channel for CQI/ PMI reporting			PUSCH (Note 3)	
PUCCH report type for CQI/ PMI			2	
Physical channel for RI reporting			PUCCH Format 2	
Reporting periodicity	ms		$N_{pd} = 5$	
PMI and CQI delay	ms		10	
ACK/NACK feedback mode			Bundling	
<i>cqi-pmi-ConfigurationIndex</i>			4	
<i>ri-ConfigurationInd</i>			1	
Note 1:	If the UE reports in an available uplink reporting instance at subframe SF#n based on PMI and CQI estimation at a downlink subframe not later than SF#(n-4), this reported PMI and wideband CQI cannot be applied at the eNB downlink before SF#(n+4).			
Note 2:	Reference measurement channel RC.9 TDD according to Table A.4-1 with one sided dynamic OCNG Pattern OP.1 TDD as described in Annex A.5.2.1.			
Note 3:	To avoid collisions between CQI/PMI reports and HARQ-ACK it is necessary to report both on PUSCH instead of PUCCH. PDCCH DCI format 0 shall be transmitted in downlink SF#4 and #9 to allow periodic CQI/PMI to multiplex with the HARQ-ACK on PUSCH in uplink SF#3 and #8.			

Table 9.5.2.2-2: Minimum requirement (TDD)

	Test 1	Test 2	Test 3
$\gamma_1$	N/A	1.05	0.9
$\gamma_2$	1	N/A	N/A
UE Category	$\geq 2$	$\geq 2$	$\geq 2$

### 9.5.3 Minimum requirement (CSI measurements in case two CSI subframe sets are configured)

#### 9.5.3.1 FDD

The minimum performance requirement in Table 9.5.3.1-2 is defined as

- a) The ratio of the throughput obtained when transmitting based on UE reported RI and that obtained when transmitting with fixed rank 1 shall be  $\geq \gamma_1$

For the parameters specified in Table 9.5.3.1-1, and using the downlink physical channels specified in Annex C.3.2, the minimum requirements are specified in Table 9.5.3.1-2.

**Table 9.5.3.1-1: RI Test (FDD)**



Parameter	Unit	Test 1		Test 2	
		Cell 1	Cell 2	Cell 1	Cell 2
Bandwidth	MHz	10		10	
PDSCH transmission mode		3	Note 10	3	Note 10
Downlink power allocation	$\rho_A$	-3		-3	
	$\rho_B$	-3		-3	
	$\sigma$	0		0	
Propagation condition and antenna configuration		2 x 2 EPA5		2 x 2 EPA5	
CodeBookSubsetRestriction bitmap		01 for fixed RI = 1 10 for fixed RI = 2 11 for UE reported RI	N/A	01 for fixed RI = 1 10 for fixed RI = 2 11 for UE reported RI	N/A
Antenna correlation		Low		Low	
RI configuration		Fixed RI=1 and follow RI	N/A	Fixed RI=1 and follow RI	N/A
$E_s/N_{oc2}$	dB	0	-12	20	6
$N_{oc}^{(j)}$	$N_{ocd}^{(j)}$	-98 (Note 3)	N/A	-102 (Note 3)	N/A
	$N_{oc2}^{(j)}$	-98 (Note 4)	N/A	-98 (Note 4)	N/A
	$N_{oc3}^{(j)}$	-98 (Note 5)	N/A	-94.8 (Note 5)	N/A
$\hat{I}_{of}^{(j)}$	dB[mW/15kHz]	-98	-110	-78	-92
Subframe Configuration		Non-MBSFN	Non-MBSFN	Non-MBSFN	Non-MBSFN
Cell Id		0	1	0	1
Time Offset between Cells	$\mu$ s	2.5 (synchronous cells)		2.5 (synchronous cells)	
ABS Pattern (Note 6)		N/A	10000000 10000000 10000000 10000000 10000000	N/A	10000000 10000000 10000000 10000000 10000000
RLM/RRM Measurement Subframe Pattern (Note 7)		10000000 10000000 10000000 10000000 10000000	N/A	10000000 10000000 10000000 10000000 10000000	N/A
CSI Subframe Sets (Note 8)	$C_{CSI,0}$	10000000 10000000 10000000 10000000 10000000 10000000	N/A	10000000 10000000 10000000 10000000 10000000 10000000	N/A
	$C_{CSI,1}$	01111111 01111111 01111111 01111111 01111111		01111111 01111111 01111111 01111111 01111111	
Number of control OFDM Symbols		3	3	3	3
Maximum number of HARQ transmissions		1		1	
Reporting mode		PUCCH 1-0		PUCCH 1-0	
Physical channel for CQI reporting		PUCCH Format 2		PUCCH Format 2	
PUCCH Report Type for CQI		4		4	
Physical channel for RI reporting		PUCCH Format 2		PUCCH Format 2	
PUCCH Report Type for RI		3		3	

Reporting periodicity	ms	$N_{\text{PRB}}=10$		$N_{\text{PRB}}=10$	
<i>cqi-pmi-ConfigurationIndex</i>		11		11	
<i>ri-ConfigurationInd</i>		5		5	
<i>cqi-pmi-ConfigurationIndex2</i>		10		10	
<i>ri-ConfigurationInd2</i>		2		2	
Cyclic prefix		Normal	Normal	Normal	Normal
Note 1:	If the UE reports in an available uplink reporting instance at subframe SF#n based on CQI estimation at a downlink subframe not later than SF#(n-4), this reported wideband CQI cannot be applied at the eNB downlink before SF#(n+4).				
Note 2:	Reference measurement channel in Cell 1 RC.2 FDD according to Table A.4-1 with one sided dynamic OCNG Pattern OP.1 FDD as described in Annex A.5.1.1.				
Note 3:	This noise is applied in OFDM symbols #1, #2, #3, #5, #6, #8, #9, #10, #12, #13 of a subframe overlapping with the aggressor ABS.				
Note 4:	This noise is applied in OFDM symbols #0, #4, #7, #11 of a subframe overlapping with the aggressor ABS.				
Note 5:	This noise is applied in all OFDM symbols of a subframe overlapping with aggressor non-ABS				
Note 6:	ABS pattern as defined in [9].				
Note 7:	Time-domain measurement resource restriction pattern for PCell measurements as defined in [7].				
Note 8:	As configured according to the time-domain measurement resource restriction pattern for CSI measurements defined in [7].				
Note 9:	Cell 1 is the serving cell. Cell 2 is the aggressor cell. The number of the CRS ports in Cell 1 and Cell 2 is the same.				
Note 10:	Downlink physical channel setup in Cell 2 in accordance with Annex C.3.3 applying OCNG pattern as defined in Annex A.5.1.5.				

Table 9.5.3.1-2: Minimum requirement (FDD)

	Test 1	Test 2
$\gamma$	0.9	1.05
UE Category	$\geq 2$	$\geq 2$

### 9.5.3.2 TDD

The minimum performance requirement in Table 9.5.3.2-2 is defined as

- a) The ratio of the throughput obtained when transmitting based on UE reported RI and that obtained when transmitting with fixed rank 1 shall be  $\geq \gamma$ .

For the parameters specified in Table 9.5.3.2-1, and using the downlink physical channels specified in Annex C.3.2, the minimum requirements are specified in Table 9.5.3.2-2.

**Table 9.5.3.2-1: RI Test (TDD)**

Parameter	Unit	Test1		Test2	
		Cell 1	Cell 2	Cell 1	Cell 2
Bandwidth	MHz	10		10	
PDSCH transmission mode		3	Note 11	3	Note 11
Uplink downlink configuration		1		1	
Special subframe configuration		4		4	
Downlink power allocation	$\rho_A$	dB		-3	
	$\rho_B$	dB		-3	
	$\sigma$	dB		0	
Propagation condition and antenna configuration		2 x 2 EPA5		2 x 2 EPA5	
CodeBookSubsetRestriction bitmap		01 for fixed RI = 1 10 for fixed RI = 2 11 for UE reported RI	N/A	01 for fixed RI = 1 10 for fixed RI = 2 11 for UE reported RI	N/A
Antenna correlation		Low		Low	
RI configuration		Fixed RI=1 and follow RI	N/A	Fixed RI=1 and follow RI	N/A
$E_s/N_{oc2}$	dB	0	-12	20	6
$N_{oc}^{(j)}$	$N_{ocd}^{(j)}$	-98 (Note 4)	N/A	-102 (Note 4)	N/A
	$N_{oc2}^{(j)}$	-98 (Note 5)	N/A	-98 (Note 5)	N/A
	$N_{oc3}^{(j)}$	-98 (Note 6)	N/A	-94.8 (Note 6)	N/A
$\hat{I}_{or}^{(j)}$	dB[mW/15k Hz]	-98	-110	-78	-92
Subframe Configuration		Non-MBSFN	Non-MBSFN	Non-MBSFN	Non-MBSFN
Cell Id		0	1	0	1
Time Offset between Cells	$\mu$ s	2.5 (synchronous cells)		2.5 (synchronous cells)	
ABS Pattern (Note 7)		N/A	0000000 001 0000000 001	N/A	000000001 000000001
RLM/RRM Measurement Subframe Pattern (Note 8)		00000000 01 00000000 01	N/A	000000001 000000001	N/A
CSI Subframe Sets (Note 9)	$C_{CSI,0}$	00000000 01 00000000 01	N/A	000000001 000000001	N/A
	$C_{CSI,1}$	11001110 00 11001110 00		1100111000 1100111000	
Number of control OFDM Symbols		3	3	3	3
Maximum number of HARQ transmissions		1		1	
Reporting mode		PUCCH 1-0		PUCCH 1-0	
Physical channel for $C_{CSI,0}$ CQI and RI reporting		PUCCH Format 2		PUCCH Format 2	
PUCCH Report Type for CQI		4		4	
Physical channel for $C_{CSI,1}$ CQI and RI reporting		PUSCH (Note 3)		PUSCH (Note 3)	

PUCCH Report Type for RI		3	3
Reporting periodicity	ms	$N_{pd}=10$	$N_{pd}=10$
ACK/NACK feedback mode		Multiplexing	Multiplexing
<i>cqi-pmi-ConfigurationIndex</i>		8	8
<i>ri-ConfigurationInd</i>		5	5
<i>cqi-pmi-ConfigurationIndex2</i>		9	9
<i>ri-ConfigurationInd2</i>		0	0
Cyclic prefix		Normal	Normal
Note 1:	If the UE reports in an available uplink reporting instance at subframe SF#n based on CQI estimation at a downlink subframe not later than SF#(n-4), this reported wideband CQI cannot be applied at the eNB downlink before SF#(n+4).		
Note 2:	Reference measurement channel in Cell 1 RC.2 TDD according to Table A.4-1 with one sided dynamic OCNG Pattern OP.1 TDD as described in Annex A.5.2.1.		
Note 3:	To avoid collisions between RI/CQI reports and HARQ-ACK it is necessary to report them on PUSCH instead of PUCCH. PDCCH DCI format 0 shall be transmitted in downlink SF#4 and #9 to allow periodic RI/CQI to multiplex with the HARQ-ACK on PUSCH in uplink subframe SF#8 and #3.		
Note 4:	This noise is applied in OFDM symbols #1, #2, #3, #5, #6, #8, #9, #10, #12, #13 of a subframe overlapping with the aggressor ABS		
Note 5:	This noise is applied in OFDM symbols #0, #4, #7, #11 of a subframe overlapping with the aggressor ABS.		
Note 6:	This noise is applied in all OFDM symbols of a subframe overlapping with aggressor non-ABS		
Note 7:	ABS pattern as defined in [9].		
Note 8:	Time-domain measurement resource restriction pattern for PCell measurements as defined in [7].		
Note 9:	As configured according to the time-domain measurement resource restriction pattern for CSI measurements defined in [7].		
Note 10:	Cell 1 is the serving cell. Cell 2 is the aggressor cell. The number of the CRS ports in Cell 1 and Cell 2 is the same.		
Note 11:	Downlink physical channel setup in Cell 2 in accordance with Annex C.3.3 applying OCNG pattern as defined in Annex A.5.2.5.		

Table 9.5.3.2-2: Minimum requirement (TDD)

	Test 1	Test 2
$\gamma_1$	0.9	1.05
UE Category	$\geq 2$	$\geq 2$

#### 9.5.4 Minimum requirement (CSI measurements in case two CSI subframe sets are configured and CRS assistance information are configured)

##### 9.5.4.1 FDD

For the parameters specified in Table 9.5.4.1-1, the minimum performance requirement in Table 9.5.4.1-2 is defined as

- The ratio of the throughput obtained when transmitting based on UE reported RI and that obtained when transmitting with fixed rank 1 shall be  $\geq \gamma_1$ ;
- The ratio of the throughput obtained when transmitting based on UE reported RI and that obtained when transmitting with fixed rank 2 shall be  $\geq \gamma_2$ ;

In Table 9.5.4.1-1, Cell 1 is the serving cell, and Cell 2 and Cell 3 are the aggressor cells. The downlink physical channel setup for Cell 1 is according to Annex C.3.2 and for Cell 2 and Cell 3 is according to Annex C.3.3, respectively. The CRS assistance information [7] including Cell 2 and Cell 3 is provided.

**Table 9.5.4.1-1: RI Test (FDD)**

Parameter	Unit	Cell 1	Cell 2	Cell 3
Bandwidth	MHz	10	10	10
PDSCH transmission mode		3	As defined in Note 1	As defined in Note 1
Downlink power allocation	$\rho_A$	dB	-3	-3
	$\rho_B$	dB	-3	-3
	$\sigma$	dB	0	N/A
Propagation condition and antenna configuration		2x2 EPA5 (Note 2)	2x2 EPA5 (Note 2)	2x2 EPA5 (Note 2)
CodeBookSubsetRestriction bitmap		01 for fixed RI = 1 10 for fixed RI = 2 11 for UE reported RI	As defined in Note 1	As defined in Note 1
$N_{oc}$ at antenna port	$N_{oc1}$	dB[mW/15k Hz]	-98 (Note 3)	N/A
	$N_{oc2}$	dB[mW/15k Hz]	-98 (Note 4)	N/A
	$N_{oc3}$	dB[mW/15k Hz]	-93 (Note 5)	N/A
$\hat{E}_s/N_{oc2}$	dB	Reference Value in Table 9.5.4.1-2 for each test	12	10
$\hat{I}_{or}^{(j)}$	dB[mW/15k Hz]	Reference Value in Table 9.5.4.1-2 for each test	-86	-88
Subframe Configuration		Non-MBSFN	Non-MBSFN	Non-MBSFN
Time Offset between Cells	$\mu$ s	N/A	3	-1
Frequency shift between Cells	Hz	N/A	300	-100
Cell Id		0	126	1
ABS pattern (Note 6)		N/A	10000000 10000000 10000000 10000000 10000000	10000000 10000000 10000000 10000000 10000000
RLM/RRM Measurement Subframe Pattern (Note 7)		10000000 10000000 10000000 10000000 10000000	N/A	N/A
CSI Subframe Sets (Note 8)	$C_{CSI,0}$	10000000 10000000 10000000 10000000 10000000	N/A	N/A
	$C_{CSI,1}$	01111111 01111111 01111111 01111111 01111111	N/A	N/A
Number of control OFDM symbols		3	Note 9	Note 9
Maximum number of HARQ transmissions		1	N/A	N/A
Reporting mode		PUCCH 1-0	N/A	N/A
Physical channel for CQI reporting		PUCCH format 2	N/A	N/A
PUCCH Report Type for CQI		4	N/A	N/A
Physical channel for RI reporting		PUCCH Format 2	N/A	N/A
PUCCH Report Type for RI		3	N/A	N/A
Reporting periodicity	ms	$N_{\text{rep}} = 10$	N/A	N/A
$cqi\text{-}pmi\text{-}ConfigurationIndex$		11	N/A	N/A
$ri\text{-}ConfigurationInd$		5	N/A	N/A

<i>cqi-pmi-ConfigurationIndex2</i>		10	N/A	N/A
<i>ri-ConfigurationInd2</i>		2	N/A	N/A
Cyclic prefix		Normal	Normal	Normal
Note 1:	Downlink physical channel setup in Cell 2 and Cell 3 in accordance with Annex C.3.3 applying OCNG pattern OP.5 FDD as defined in Annex A.5.1.5.			
Note 2:	The propagation conditions for Cell 1, Cell 2 and Cell 3 are statistically independent.			
Note 3:	This noise is applied in OFDM symbols #1, #2, #3, #5, #6, #8, #9, #10, #12, #13 of a subframe overlapping with the aggressor ABS.			
Note 4:	This noise is applied in OFDM symbols #0, #4, #7, #11 of a subframe overlapping with the aggressor ABS.			
Note 5:	This noise is applied in all OFDM symbols of a subframe overlapping with aggressor non-ABS			
Note 6:	ABS pattern as defined in [9]. PDSCH other than SIB1/paging and its associated PDCCH/PCFICH are transmitted in the serving cell subframe when the subframe is overlapped with the ABS subframe of aggressor cell and the subframe is available in the definition of the reference channel.			
Note 7:	Time-domain measurement resource restriction pattern for PCell measurements as defined in [7]			
Note 8:	As configured according to the time-domain measurement resource restriction pattern for CSI measurements defined in [7].			
Note 9:	The number of control OFDM symbols is not available for ABS and is 3 for the subframe indicated by "0" of ABS pattern.			
Note 10:	If the UE reports in an available uplink reporting instance at subframe SF#n based on CQI estimation at a downlink subframe not later than SF#(n-4), this reported wideband CQI cannot be applied at the eNB downlink before SF#(n+4).			
Note 11:	Reference measurement channel in Cell 1 RC.2 FDD according to Table A.4-1 with one sided dynamic OCNG Pattern OP.1 FDD as described in Annex A.5.1.1.			
Note 12:	The number of the CRS ports in Cell1, Cell2 and Cell 3 is the same.			
Note 13:	SIB-1 will not be transmitted in Cell2 and Cell 3 in this test.			

Table 9.5.4.1-2: Minimum requirement (FDD)

	Test 1	Test 2	Test 3
$\bar{E}_s / N_{oc,2}$ for Cell 1 (dB)	4	20	20
$\hat{I}_{or}^{(j)}$ for Cell 1 (dB[mW/15kHz])	-94	-78	-78
Antenna correlation	High for Cell 1, low for Cell 2 and Cell 3	Low for Cell 1, Cell 2 and Cell 3	High for Cell 1, low for Cell 2 and Cell 3
$\gamma_1$	N/A	1.05	0.9
$\gamma_2$	1.05	N/A	N/A
UE Category	$\geq 2$	$\geq 2$	$\geq 2$

### 9.5.4.2 TDD

For the parameters specified in Table 9.5.4.2-1, the minimum performance requirement in Table 9.5.4.2-2 is defined as

- The ratio of the throughput obtained when transmitting based on UE reported RI and that obtained when transmitting with fixed rank 1 shall be  $\geq \gamma_1$ ;
- The ratio of the throughput obtained when transmitting based on UE reported RI and that obtained when transmitting with fixed rank 2 shall be  $\geq \gamma_2$ ;

In Table 9.5.4.2-1, Cell 1 is the serving cell, and Cell 2 and Cell 3 are the aggressor cells. The downlink physical channel setup for Cell 1 is according to Annex C.3.2 and for Cell 2 and Cell 3 is according to Annex C.3.3, respectively. The CRS assistance information [7] including Cell 2 and Cell 3 is provided.



**Table 9.5.4.2-1: RI Test (TDD)**

Parameter		Unit	Cell 1	Cell 2	Cell 3
Bandwidth		MHz	10	10	10
PDSCH transmission mode			3	As defined in Note 1	As defined in Note 1
Uplink downlink configuration			1	1	1
Special subframe configuration			4	4	4
Downlink power allocation	$\rho_A$	dB	-3	-3	-3
	$\rho_B$	dB	-3	-3	-3
	$\sigma$	dB	0	N/A	N/A
Propagation condition and antenna configuration			2x2 EPA5 (Note 2)	2x2 EPA5 (Note 2)	2x2 EPA5 (Note 2)
CodeBookSubsetRestriction bitmap			01 for fixed RI = 1 10 for fixed RI = 2 11 for UE reported RI	As defined in Note 1	As defined in Note 1
$N_{oc}$ at antenna port	$N_{oc1}$	dB[mW/15k Hz]	-98 (Note 3)	N/A	N/A
	$N_{oc2}$	dB[mW/15k Hz]	-98 (Note 4)	N/A	N/A
	$N_{oc3}$	dB[mW/15k Hz]	-93 (Note 5)	N/A	N/A
$\hat{E}_s / N_{oc2}$		dB	Reference Value in Table 9.5.4.2-2 for each test	12	10
$\hat{I}_{or}^{(j)}$		dB[mW/15k Hz]	Reference Value in Table 9.5.4.2-2 for each test	-86	-88
Subframe Configuration			Non-MBSFN	Non-MBSFN	Non-MBSFN
Time Offset between Cells		$\mu$ s	N/A	3	-1
Frequency shift between Cells		Hz	N/A	300	-100
Cell Id			0	126	1
ABS pattern (Note 6)			N/A	000000001 000000001	000000001 000000001
RLM/RRM Measurement Subframe Pattern (Note 7)			000000001 000000001	N/A	N/A
CSI Subframe Sets (Note 8)	$C_{CSI,0}$		000000001 000000001	N/A	N/A
	$C_{CSI,1}$		1100111000 1100111000	N/A	N/A
Number of control OFDM symbols			3	Note 9	Note 9
Maximum number of HARQ transmissions			1	N/A	N/A
Reporting mode			PUCCH 1-0	N/A	N/A
Physical channel for $C_{CSI,0}$ CQI and RI reporting			PUCCH format 2	N/A	N/A
Physical channel for $C_{CSI,1}$ CQI and RI reporting			PUSCH (Note 14)	N/A	N/A
PUCCH Report Type for CQI			4	N/A	N/A
PUCCH Report Type for RI			3	N/A	N/A
Reporting periodicity		ms	$N_{rep} = 10$	N/A	N/A
ACK/NACK feedback mode			Multiplexing	N/A	N/A
$cqi-pmi-ConfigurationIndex$			8	N/A	N/A
$ri-ConfigurationInd$			5	N/A	N/A
$cqi-pmi-ConfigurationIndex2$			9	N/A	N/A
$ri-ConfigurationInd2$			0	N/A	N/A
Cyclic prefix			Normal	Normal	Normal

Note 1:	Downlink physical channel setup in Cell 2 and Cell 3 in accordance with Annex C.3.3 applying OCNG pattern OP.5 TDD as defined in Annex A.5.2.5.
Note 2:	The propagation conditions for Cell 1, Cell 2 and Cell 3 are statistically independent.
Note 3:	This noise is applied in OFDM symbols #1, #2, #3, #5, #6, #8, #9, #10, #12, #13 of a subframe overlapping with the aggressor ABS.
Note 4:	This noise is applied in OFDM symbols #0, #4, #7, #11 of a subframe overlapping with the aggressor ABS.
Note 5:	This noise is applied in all OFDM symbols of a subframe overlapping with aggressor non-ABS
Note 6:	ABS pattern as defined in [9]. PDSCH other than SIB1/paging and its associated PDCCH/PCFICH are transmitted in the serving cell subframe when the subframe is overlapped with the ABS subframe of aggressor cell and the subframe is available in the definition of the reference channel.
Note 7:	Time-domain measurement resource restriction pattern for PCell measurements as defined in [7]
Note 8:	As configured according to the time-domain measurement resource restriction pattern for CSI measurements defined in [7].
Note 9:	The number of control OFDM symbols is not available for ABS and is 3 for the subframe indicated by "0" of ABS pattern.
Note 10:	If the UE reports in an available uplink reporting instance at subframe SF#n based on CQI estimation at a downlink subframe not later than SF#(n-4), this reported wideband CQI cannot be applied at the eNB downlink before SF#(n+4).
Note 11:	Reference measurement channel in Cell 1 RC.2 TDD according to Table A.4-1 with one sided dynamic OCNG Pattern OP.1 TDD as described in Annex A.5.2.1.
Note 12:	The number of the CRS ports in Cell1, Cell2 and Cell 3 is the same.
Note 13:	SIB-1 will not be transmitted in Cell2 and Cell 3 in this test.
Note 14:	To avoid collisions between RI/CQI reports and HARQ-ACK it is necessary to report them on PUSCH instead of PUCCH. PDCCH DCI format 0 shall be transmitted in downlink SF#4 and #9 to allow periodic RI/CQI to multiplex with the HARQ-ACK on PUSCH in uplink subframe SF#8 and #3.

Table 9.5.4.2-2: Minimum requirement (TDD)

	Test 1	Test 2	Test 3
$\bar{E}_s / N_{oc2}$ for Cell 1 (dB)	4	20	20
$\hat{I}_{or}^{(j)}$ for Cell 1 (dB[mW/15kHz])	-94	-78	-78
Antenna correlation	High for Cell 1, low for Cell 2 and Cell 3	Low for Cell 1, Cell 2 and Cell 3	High for Cell 1, low for Cell 2 and Cell 3
$\gamma_1$	N/A	1.05	0.9
$\gamma_2$	1.05	N/A	N/A
UE Category	$\geq 2$	$\geq 2$	$\geq 2$

### 9.5.5 Minimum requirement (with CSI process)

Each CSI process is associated with a CSI-RS resource and a CSI-IM resource as shown in Table 9.5.5-1.

For UE supports one CSI process, CSI process 0 is configured for Test 1 and Test 2, but CSI process 1 is not configured for Test 2. The corresponding  $\gamma$  requirements for Test 1 and Test 2 shall be fulfilled. The requirement on reported RI for CSI process 1 in Test 2 is not applicable.

For UE supports multiple CSI processes, CSI process 0 is configured for Test 1 and CSI processes 0 and 1 are configured for Test 2. The corresponding  $\gamma$  requirements for Test 1 and Test 2 shall be fulfilled, and also the requirement on reported RI for CSI process 1 in Test 2.

Table 9.5.5-1: Configuration of CSI processes

	CSI process 0	CSI process 1
CSI-RS resource	CSI-RS signal 0	CSI-RS signal 1
CSI-IM resource	CSI-IM resource 0	CSI-IM resource 1

### 9.5.5.1 FDD

The minimum performance requirement in Table 9.5.5.1-2 is defined as

- a) The ratio of the throughput obtained when transmitting based on UE reported RI and that obtained when transmitting with fixed rank 1 shall be  $\geq \gamma$ ;
- b) The ratio of the throughput obtained when transmitting based on UE reported RI and that obtained when transmitting with fixed rank 2 shall be  $\geq \gamma$ ;
- c) For Test 2, the RI reported for CSI process 1 shall be the same as the most recent RI reported for CSI process 0 if UE is configured with multiple CSI processes.

For the parameters specified in Table 9.5.5.1-1, and using the downlink physical channels specified in Annex C.3.2, the minimum requirements are specified in Table 9.5.5.1-2.

**Table 9.5.5.1-1: RI Test (FDD)**

Parameter	Unit	Test 1		Test 2	
		TP1	TP2	TP1	TP2
Bandwidth	MHz	10 MHz		10 MHz	
Transmission mode		10	10	10	10
Downlink power allocation	$\rho_A$	0		0	
	$\rho_B$	0		0	
	$\rho_C$	0	0	0	0
	$\sigma$	0		0	
SNR	dB	0	0	20	20
$\hat{I}_{or}^{(j)}$	dB[mW/15kHz]	-98	-98	-78	-78
$N_{oc}^{(j)}$	dB[mW/15kHz]	-98		-98	
Propagation channel		EPA 5 Low	EPA 5 Low	EPA 5 Low	EPA 5 High
Antenna configuration		2x2	2x2	2x2	2x2
Beamforming Model		As specified in Section B.4.3		As specified in Section B.4.3	
Timing offset between TPs	us	0		0	
Frequency offset between TPs	Hz	0		0	
Cell-specific reference signals		Antenna ports 0		Antenna ports 0	
CSI-RS signal 0		Antenna ports 15,16	N/A	Antenna ports 15,16	N/A
CSI-RS 0 periodicity and subframe offset $T_{CSI-RS} / \Delta_{CSI-RS}$		5/1	N/A	5/1	N/A
CSI-RS 0 configuration		0	N/A	0	N/A
CSI-RS signal 1		N/A	Antenna ports 15,16	N/A	Antenna ports 15,16
CSI-RS 1 periodicity and subframe offset $T_{CSI-RS} / \Delta_{CSI-RS}$		N/A	5/1	N/A	5/1
CSI-RS 1 configuration		N/A	3	N/A	3
Zero-power CSI-RS 0 configuration $l_{CSI-RS} / ZeroPowerCSI-RS$ bitmap		N/A	1 / 10000010000 00000	N/A	1] / 10000010000 00000
Zero-power CSI-RS 1 configuration $l_{CSI-RS} / ZeroPowerCSI-RS$ bitmap		1 / 00110000000 00000	N/A	1 / 00110000000 00000	N/A
CSI-IM 0 periodicity and subframe offset $T_{CSI-IM} / \Delta_{CSI-IM}$		5/1	N/A	5/1	N/A
CSI-IM 0 configuration		2	N/A	2	N/A
CSI-IM 1 periodicity and subframe offset $T_{CSI-IM} / \Delta_{CSI-IM}$		N/A	5/1	N/A	5/1
CSI-IM 1 configuration		N/A	6	N/A	6
RI configuration		Fixed RI=2 and follow RI	N/A	Fixed RI=1 and follow RI	N/A
Physical channel for CQI/PMI reporting		PUSCH (Note 6)	N/A	PUSCH (Note 6)	PUSCH (Note 6)
PUCCH Report Type for CQI/PMI		2	N/A	2	2
Physical channel for RI reporting		PUCCH Format 2	N/A	PUCCH Format 2	PUCCH Format 2
PUCCH Report Type for RI		3	N/A	3	3
CSI process 0 (Note 7)	CSI-RS	CSI-RS 0	N/A	CSI-RS 0	N/A
	CSI-IM	CSI-IM 0	N/A	CSI-IM 0	N/A
	Reporting mode	PUCCH 1-1	N/A	PUCCH 1-1	N/A
	Reporting periodicity	ms	$N_{pd} = 5$	$N_{pd} = 5$	N/A
	CQI delay	ms	8	10	N/A
	$cqi-pmi-ConfigurationIndex$ $ri-ConfigIndex$		6	N/A	6
CSI process 1 (Note 7, Note 9)	CSI-RS	N/A	N/A	N/A	CSI-RS 1
	CSI-IM	N/A	N/A	N/A	CSI-IM 1
	Reporting mode	N/A	N/A	N/A	PUCCH 1-1
	Reporting periodicity	ms	N/A	N/A	$N_{pd} = 5$
	CQI delay	ms	N/A	N/A	10

	<i>cqi-pmi-ConfigurationIndex</i>		N/A	N/A	N/A	4
	<i>ri-ConfigIndex</i>		N/A	N/A	N/A	1
CSI process for PDSCH scheduling			CSI process 0		CSI process 0	
Cell ID			0	6	0	6
Quasi-co-located CSI-RS			CSI-RS 0	CSI-RS 1	CSI-RS 0	CSI-RS 1
Quasi-co-located CRS			Same Cell ID as Cell 1	Same Cell ID as Cell 2	Same Cell ID as Cell 1	Same Cell ID as Cell 2
PMI for subframe 2, 3, 4, 7, 8 and 9			010000 for fixed RI = 2 010011 for UE reported RI	100000	000011 for fixed RI = 1 010011 for UE reported RI	N/A
PMI for subframe 1 and 6			100000	100000	100000	N/A
Max number of HARQ transmissions			1	N/A	1	N/A
Note 1:	If the UE reports in an available uplink reporting instance at subframe SF#n based on CQI estimation at a downlink SF not later than SF#(n-4), this reported wideband CQI cannot be applied at the eNB downlink before SF#(n+4)					
Note 2:	3 symbols allocated to PDCCH					
Note 3:	Reference measurement channel RC.13 FDD according to Table A.4-1. PDSCH transmission is scheduled on subframe 2, 3, 4, 7, 8 and 9 from TP1.					
Note 4:	TM10 OCNB as specified in A.5.1.8 is transmitted on subframe 1 and 6 from TP1.					
Note 5:	TM10 OCNB as specified in A.5.1.8 is transmitted on subframe 1, 2, 3, 4, 6, 7, 8 and 9 from TP2 for Test 1; TP2 is blanked for Test 2.					
Note 6:	To avoid collisions between CQI/PMI reports and HARQ-ACK it is necessary to report both on PUSCH instead of PUCCH. PDCCH DCI format 0 shall be transmitted in downlink SF#1 and #6 to allow periodic CQI/PMI to multiplex with the HARQ-ACK on PUSCH in uplink SF#0 and #5.					
Note 7:	If UE supports multiple CSI processes, CSI process 0 is configured as 'RI-reference CSI process' for CSI process 1.					
Note 8:	PDCCH DCI format 0 with a trigger for aperiodic CQI shall be transmitted in downlink SF#1 and #6 to allow aperiodic CQI/PMI/RI to be transmitted in uplink SF#0 and #5.					
Note 9:	If UE supports one CSI process, CSI process 1 is not configured in Test 2.					

Table 9.5.5.1-2: Minimum requirement (FDD)

	Test 1	Test 2
$\gamma_1$	N/A	1.0
$\gamma_2$	1.0	N/A
UE Category	$\geq 2$	$\geq 2$

### 9.5.5.2 TDD

The minimum performance requirement in Table 9.5.5.2-2 is defined as

- The ratio of the throughput obtained when transmitting based on UE reported RI and that obtained when transmitting with fixed rank 1 shall be  $\geq \gamma_1$ ;
- The ratio of the throughput obtained when transmitting based on UE reported RI and that obtained when transmitting with fixed rank 2 shall be  $\geq \gamma_2$ ;
- For Test 2, the RI reported for CSI process 1 shall be the same as the most recent RI reported for CSI process 0 if UE is configured with multiple CSI processes.

For the parameters specified in Table 9.5.5.2-1, and using the downlink physical channels specified in Annex C.3.2, the minimum requirements are specified in Table 9.5.5.2-2.

**Table 9.5.5.2-1: RI Test (TDD)**



Parameter	Unit	Test 1		Test 2	
		TP1	TP2	TP1	TP2
Bandwidth	MHz	10 MHz		10 MHz	
Transmission mode		10	10	10	10
Downlink power allocation	$\rho_A$	0		0	
	$\rho_B$	0		0	
	$\rho_C$	0	0	0	0
	$\sigma$	0		0	
Uplink downlink configuration		2	2	2	2
Special subframe configuration		4	4	4	4
SNR	dB	0	0	20	20
$\hat{I}_{or}^{(j)}$	dB[mW/15kHz]	-98	-98	-78	-78
$N_{oc}^{(j)}$	dB[mW/15kHz]	-98		-98	
Propagation channel		EPA 5 Low	EPA 5 Low	EPA 5 Low	EPA 5 High
Antenna configuration		2x2	2x2	2x2	2x2
Beamforming Model		As specified in Section B.4.3		As specified in Section B.4.3	
Timing offset between TPs	us	0		0	
Frequency offset between TPs	Hz	0		0	
Cell-specific reference signals		Antenna ports 0		Antenna ports 0	
CSI-RS signal 0		Antenna ports 15,16	N/A	Antenna ports 15,16	N/A
CSI-RS 0 periodicity and subframe offset $T_{CSI-RS} / \Delta_{CSI-RS}$		5/3	N/A	5/3	N/A
CSI-RS 0 configuration		0	N/A	0	N/A
CSI-RS signal 1		N/A	Antenna ports 15,16	N/A	Antenna ports 15,16
CSI-RS 1 periodicity and subframe offset $T_{CSI-RS} / \Delta_{CSI-RS}$		N/A	5/3	N/A	5/3
CSI-RS 1 configuration		N/A	3	N/A	3
Zero-power CSI-RS 0 configuration $l_{CSI-RS} / \text{ZeroPowerCSI-RS}$ bitmap		N/A	3 / 10000010000000000	N/A	3 / 10000010000000000
Zero-power CSI-RS 1 configuration $l_{CSI-RS} / \text{ZeroPowerCSI-RS}$ bitmap		3 / 00110000000000000	N/A	3 / 00110000000000000	N/A
CSI-IM 0 periodicity and subframe offset $T_{CSI-IM} / \Delta_{CSI-IM}$		5/3	N/A	5/3	N/A
CSI-IM 0 configuration		2	N/A	2	N/A
CSI-IM 1 periodicity and subframe offset $T_{CSI-IM} / \Delta_{CSI-IM}$		N/A	5/3	N/A	5/3
CSI-IM 1 configuration		N/A	6	N/A	6
RI configuration		Fixed RI=2 and follow RI	N/A	Fixed RI=1 and follow RI	N/A
CSI process 0 (Note 6, 7)	CSI-RS	CSI-RS 0	N/A	CSI-RS 0	N/A
	CSI-IM	CSI-IM 0	N/A	CSI-IM 0	N/A
	Reporting mode	PUSCH 3-1	N/A	PUSCH 3-1	N/A
	Reporting Interval	ms	5	ms	5
	CQI delay	ms	11	ms	11
CSI process 1 (Note 6, 7, 8)	CSI-RS	N/A	N/A	N/A	CSI-RS 1
	CSI-IM	N/A	N/A	N/A	CSI-IM 1
	Reporting mode	N/A	N/A	N/A	PUSCH 3-1
	Reporting Interval	ms	N/A	ms	5
	CQI delay	ms	N/A	ms	11
CSI process for PDSCH scheduling		CSI process 0		CSI process 0	
Cell ID		0	6	0	6
Quasi-co-located CSI-RS		CSI-RS 0	CSI-RS 1	CSI-RS 0	CSI-RS 1
Quasi-co-located CRS		Same Cell ID as Cell 1	Same Cell ID as Cell 2	Same Cell ID as Cell 1	Same Cell ID as Cell 2
PMI for subframe 4 and 9		010000 for fixed RI = 2 010011 for UE reported RI	100000	000011 for fixed RI = 1 010011 for UE reported RI	N/A
PMI for subframe 3 and 8		100000	100000	100000	N/A

Max number of HARQ transmissions		1	N/A	1	N/A
ACK/NACK feedback mode		Multiplexing	N/A	Multiplexing	N/A
Note 1:	If the UE reports in an available uplink reporting instance at subframe SF#n based on CQI estimation at a downlink SF not later than SF#(n-4), this reported wideband CQI cannot be applied at the eNB downlink before SF#(n+4)				
Note 2:	3 symbols allocated to PDCCH				
Note 3:	Reference measurement channel RC.13 TDD according to Table A.4-1. PDSCH transmission is scheduled on subframe 4 and 9 from TP1.				
Note 4:	TM10 OCNG as specified in A.5.2.8 is transmitted on subframe 3 and 8 from TP1.				
Note 5:	TM10 OCNG as specified in A.5.2.8 is transmitted on subframe 3, 4, 8 and 9 from TP2 for Test 1; TP2 is blanked for Test 2.				
Note 6:	Reported wideband CQI and PMI are used and sub-band CQI is discarded.				
Note 7:	If UE supports multiple CSI processes, CSI process 0 is configured as 'RI-reference CSI process' for CSI process 1.				
Note 8:	If UE supports one CSI process, CSI process 1 is not configured in Test 2.				
Note 9:	PDCCH DCI format 0 with a trigger for aperiodic CQI shall be transmitted in downlink SF#3 and #8 to allow aperiodic CQI/PMI/RI to be transmitted in uplink SF#7 and #2.				

Table 9.5.5.2-2: Minimum requirement (TDD)

	Test 1	Test 2
$\gamma_1$	N/A	1.0
$\gamma_2$	1.0	N/A
UE Category	$\geq 2$	$\geq 2$

## 9.6 Additional requirements for carrier aggregation

This clause includes requirements for the reporting of channel state information (CSI) with the UE configured for carrier aggregation. The purpose is to verify that the channel state for each cell is correctly reported with multiple cells configured for periodic reporting.

### 9.6.1 Periodic reporting on multiple cells (Cell-Specific Reference Symbols)

#### 9.6.1.1 FDD

The following requirements apply to UE Category  $\geq 3$ . For CA with 2 DL CC, for the parameters specified in Table 9.6.1.1-1 and Table 9.6.1.1-2, and using the downlink physical channels specified in tables C.3.2-1 and C.3.2-2 on each cell, the difference between the wideband CQI indices of Pcell and Scell reported shall be such that

$$\text{wideband CQI}_{\text{Pcell}} - \text{wideband CQI}_{\text{Scell}} \geq 2$$

for more than 90% of the time.

**Table 9.6.1.1-1: Parameters for PUCCH 1-0 static test on multiple cells (FDD, 2 DL CA)**

Parameter	Unit	Pcell	Scell
PDSCH transmission mode			1
Downlink power allocation	$\rho_A$	dB	0
	$\rho_B$	dB	0
Propagation condition and antenna configuration		AWGN (1 x 2)	
SNR	dB	10	4
$\hat{I}_{or}^{(j)}$	dB[mW/15kHz]	-88	-94
$N_{oc}^{(j)}$	dB[mW/15kHz]	-98	-98
Physical channel for CQI reporting		PUCCH Format 2	
PUCCH Report Type		4	
Reporting periodicity	ms	$N_{pd} = 10$	
<i>cqi-pmi-ConfigurationIndex</i>		11	16 (shift of 5 ms relative to Pcell)
Note 1:	3 symbols are allocated to PDCCH. No PDSCH for user data is scheduled for the UE with one sided dynamic OCNG Pattern OP.1 FDD as described in Annex A.5.1.1.		
Note 2:	Void		

**Table 9.6.1.1-2: PUCCH 1-0 static test (FDD, 2 DL CA)**

Test number	Bandwidth combination
1	10MHz for both cells
2	20MHz for both cells
3	5MHz for both cells
4	5MHz for PCell and 10MHz for SCell
5	5MHz for PCell and 15MHz for SCell
Note 1:	The applicability of requirements for different CA configurations and bandwidth combination sets is defined in 9.1.1.2. The test coverage for different number of component carriers is defined in 9.1.1.3.
Note 2:	Mapping of PCell and Scell to the CCs shall be constant for all the iterations during the test. Each execution of the test shall use the same mapping.

The following requirements for 3DL CA apply to UE Category  $\geq 5$ . For CA with 3 DL CC, for the parameters specified in Table 9.6.1.1-3 and Table 9.6.1.1-4, and using the downlink physical channels specified in tables C.3.2-1 and C.3.2-2 on each cell, the difference between the wideband CQI indices of PCell and SCell1 reported, and the difference between the wideband CQI indices of SCell 1 and SCell2 reported shall be such that

$$\text{wideband CQI}_{\text{PCell}} - \text{wideband CQI}_{\text{SCell1}} \geq 2$$

$$\text{wideband CQI}_{\text{SCell1}} - \text{wideband CQI}_{\text{SCell2}} \geq 2$$

for more than 90% of the time.

The following requirements for 4DL CA apply to UE Category  $\geq 8$ . For CA with 4 DL CC, for the parameters specified in Table 9.6.1.1-3 and Table 9.6.1.1-5, and using the downlink physical channels specified in tables C.3.2-1 and C.3.2-2 on each cell, the difference between the wideband CQI indices of PCell and SCell1 reported, and the difference between the wideband CQI indices of SCell 1 and SCell2, and SCell 1 and SCell 3 reported shall be such that

$$\text{wideband CQI}_{\text{PCell}} - \text{wideband CQI}_{\text{SCell1}} \geq 2$$

$$\text{wideband CQI}_{\text{SCell1}} - \text{wideband CQI}_{\text{SCell2}} \geq 2$$

$$\text{wideband CQI}_{\text{SCell1}} - \text{wideband CQI}_{\text{SCell3}} \geq 2$$

for more than 90% of the time.

**Table 9.6.1.1-3: Parameters for PUCCH 1-0 static test on multiple cells (FDD, 3 and 4 DL CA)**

Parameter	Unit	Pcell	Scell1	Scell2, 3
PDSCH transmission mode				1
Downlink power allocation	$\rho_A$	dB		
	$\rho_B$	dB		
Propagation condition and antenna configuration		AWGN (1 x 2)		
SNR	dB	12	6	0
$\hat{I}_{or}^{(j)}$	dB[mW/15kHz]	-86	-92	-98
$N_{oc}^{(j)}$	dB[mW/15kHz]	-98	-98	-98
Physical channel for CQI reporting		PUCCH Format 2		
PUCCH Report Type		4		
Reporting periodicity	ms	$N_{pd} = 20$		
<i>cqi-pmi-ConfigurationIndex</i>		21	26 (shift of 5 ms relative to Pcell)	31 for Scell2 (shift of 10 ms relative to Pcell) , 36 for Scell3 (shift of 15ms relative to Pcell)
Note 1: 3 symbols are allocated to PDCCH. No PDSCH for user data is scheduled for the UE with one sided dynamic OCNG Pattern OP.1 FDD as described in Annex A.5.1.1.				
Note 2: Void				

**Table 9.6.1.1-4: PUCCH 1-0 static test (FDD, 3 DL CA)**

Test number	Bandwidth combination (MHz)
1	3x20
2	20+20+15
3	20+20+10
4	20+15+15
5	20+15+10
6	20+10+10
7	15+15+10
8	20+10+5
9	20+15+5
10	10+10+5
11	5+5+20
12	3x10
13	5+5+10
Note 1: The applicability of requirements for different CA configurations and bandwidth combination sets is defined in 9.1.1.2. The test coverage for different number of component carriers is defined in 9.1.1.3.	
Note 2: If more than one cell can be configured as PCell, choose one of the cells with the smallest bandwidth as PCell. Mapping of PCell and Scells to the CCs shall be constant for all the iterations during the test. Each execution of the test shall use the same mapping.	

**Table 9.6.1.1-5: PUCCH 1-0 static test (FDD, 4 DL CA)**

Test number	Bandwidth combination (MHz)
1	4x20
2	20+20+20+10
3	20+20+10+10
4	20+20+10+5
5	20+10+10+5
6	15+3x20
7	2x15+2x20
8	10+15+2x20
9	3x10+20
10	2x5+2x20
11	2x5+10+20
12	4x10
Note 1:	The applicability of requirements for different CA configurations and bandwidth combination sets is defined in 9.1.1.2. The test coverage for different number of component carriers is defined in 9.1.1.3.
Note 2:	If more than one cell can be configured as PCell, choose one of the cells with the smallest bandwidth as PCell. Mapping of PCell and SCells to the CCs shall be constant for all the iterations during the test. Each execution of the test shall use the same mapping.

The following requirements for 5DL CA apply to UE Category 8 and  $\geq 11$ . For CA with 5 DL CC, for the parameters specified in Table 9.6.1.1-6 and Table 9.6.1.1-7, and using the downlink physical channels specified in tables C.3.2-1 and C.3.2-2 on each cell, the difference between the wideband CQI indices of PCell and SCell1 reported, and the difference between the wideband CQI indices of SCell 1 and SCell2, SCell 1 and SCell 3, and SCell 1 and SCell 4 reported shall be such that

$$\text{wideband CQI}_{\text{PCell}} - \text{wideband CQI}_{\text{SCell1}} \geq 2$$

$$\text{wideband CQI}_{\text{SCell1}} - \text{wideband CQI}_{\text{SCell2}} \geq 2$$

$$\text{wideband CQI}_{\text{SCell1}} - \text{wideband CQI}_{\text{SCell3}} \geq 2$$

$$\text{wideband CQI}_{\text{SCell1}} - \text{wideband CQI}_{\text{SCell4}} \geq 2$$

for more than 90% of the time.

**Table 9.6.1.1-6: Parameters for PUCCH 1-0 static test on multiple cells (FDD, 5 DL CA)**

Parameter	Unit	Pcell	Scell1	Scell2, 3, 4
PDSCCH transmission mode		1		
Downlink power allocation	$\rho_A$	0		
	$\rho_B$	0		
Propagation condition and antenna configuration		AWGN (1 x 2)		
SNR	dB	12	6	0
$\hat{I}_{or}^{(j)}$	dB[mW/15kHz]	-86	-92	-98
$N_{oc}^{(j)}$	dB[mW/15kHz]	-98	-98	-98
Physical channel for CQI reporting		PUCCH Format 2		
PUCCH Report Type		4		
Reporting periodicity	ms	$N_{pd} = 40$		
<i>cqi-pmi-ConfigurationIndex</i>		41	46 (shift of 5 ms relative to Pcell)	51 for Scell 2 (shift of 10 ms relative to Pcell), 56 for Scell 3 (shift of 15ms relative to Pcell), 61 for Scell4 (shift of 20ms relative to Pcell)
Note 1:	3 symbols are allocated to PDCCH. No PDSCH for user data is scheduled for the UE with one sided dynamic OCNB Pattern OP.1 FDD as described in Annex A.5.1.1.			
Note 2:	Void			

**Table 9.6.1.1-7: PUCCH 1-0 static test (FDD, 5 DL CA)**

Test number	Bandwidth combination (MHz)
1	5x20
2	15+4x20
3	10+4x20
4	2x10+3x20
5	5+10+3x20
6	3x10+2x20
7	4x10+20
Note 1:	The applicability of requirements for different CA configurations and bandwidth combination sets is defined in 9.1.1.2. The test coverage for different number of component carriers is defined in 9.1.1.3.
Note 2:	If more than one cell can be configured as PCell, choose one of the cells with the smallest bandwidth as PCell. Mapping of PCell and Scells to the CCs shall be constant for all the iterations during the test. Each execution of the test shall use the same mapping.

The following requirements for 6DL CA apply to UE Category 8 and  $\geq 11$ . For CA with 6 DL CC, for the parameters specified in Table 9.6.1.1-8 and Table 9.6.1.1-9, and using the downlink physical channels specified in tables C.3.2-1 and C.3.2-2 on each cell, the difference between the wideband CQI indices of PCell and SCell1 reported, and the difference between the wideband CQI indices of SCell 1 and SCell2, SCell 1 and SCell 3, SCell 1 and SCell 4, and SCell 1 and SCell 5 reported shall be such that

$$\text{wideband CQI}_{\text{PCell}} - \text{wideband CQI}_{\text{SCell1}} \geq 2$$

$$\text{wideband CQI}_{\text{SCell1}} - \text{wideband CQI}_{\text{SCell2}} \geq 2$$

$$\text{wideband CQI}_{\text{SCell1}} - \text{wideband CQI}_{\text{SCell3}} \geq 2$$

$$\text{wideband CQI}_{\text{SCell1}} - \text{wideband CQI}_{\text{SCell4}} \geq 2$$

$$\text{wideband CQI}_{\text{SCell1}} - \text{wideband CQI}_{\text{SCell5}} \geq 2$$

for more than 90% of the time.

**Table 9.6.1.1-8: Parameters for PUCCH 1-0 static test on multiple cells (FDD, 6 DL CA)**

Parameter	Unit	Pcell	Scell1	Scell2, 3, 4, 5
PD SCH transmission mode		1		
Downlink power allocation	$\rho_A$	0		
	$\rho_B$	0		
Propagation condition and antenna configuration		AWGN (1 x 2)		
SNR	dB	12	6	0
$\hat{I}_{or}^{(j)}$	dB[mW/15kHz]	-86	-92	-98
$N_{oc}^{(j)}$	dB[mW/15kHz]	-98	-98	-98
Physical channel for CQI reporting		PUCCH Format 2		
PUCCH Report Type		4		
Reporting periodicity	ms	$N_{pd} = 40$		
<i>cqi-pmi-ConfigurationIndex</i>		41	46 (shift of 5 ms relative to Pcell)	51 for Scell 2 (shift of 10 ms relative to Pcell), 56 for Scell 3 (shift of 15ms relative to Pcell), 61 for Scell4 (shift of 20ms relative to Pcell), 66 for Scell5 (shift of 25ms relative to Pcell)
Note 1:	3 symbols are allocated to PD CCH. No PD SCH for user data is scheduled for the UE with one sided dynamic OCNG Pattern OP.1 FDD as described in Annex A.5.1.1.			
Note 2:	Void			

**Table 9.6.1.1-9: PUCCH 1-0 static test (FDD, 6 DL CA)**

Test number	Bandwidth combination (MHz)
1	6x20
Note 1:	The applicability of requirements for different CA configurations and bandwidth combination sets is defined in 9.1.1.2. The test coverage for different number of component carriers is defined in 9.1.1.3.
Note 2:	If more than one cell can be configured as PCell, choose one of the cells with the smallest bandwidth as PCell. Mapping of PCell and Scells to the CCs shall be constant for all the iterations during the test. Each execution of the test shall use the same mapping.

The following requirements for 7DL CA apply to UE Category 8 and  $\geq 11$ . For CA with 7 DL CC, for the parameters specified in Table 9.6.1.1-10 and Table 9.6.1.1-11, and using the downlink physical channels specified in tables C.3.2-1 and C.3.2-2 on each cell, the difference between the wideband CQI indices of PCell and SCell1 reported, and the difference between the wideband CQI indices of SCell 1 and SCell2, SCell 1 and SCell 3, SCell 1 and SCell 4, SCell 1 and SCell 5, and SCell 1 and SCell 6 reported shall be such that

$$\text{wideband CQI}_{\text{PCell}} - \text{wideband CQI}_{\text{SCell1}} \geq 2$$

$$\text{wideband CQI}_{\text{SCell1}} - \text{wideband CQI}_{\text{SCell2}} \geq 2$$

$$\text{wideband CQI}_{\text{SCell1}} - \text{wideband CQI}_{\text{SCell3}} \geq 2$$

$$\text{wideband CQI}_{\text{SCell1}} - \text{wideband CQI}_{\text{SCell4}} \geq 2$$

$$\text{wideband CQI}_{\text{SCell1}} - \text{wideband CQI}_{\text{SCell5}} \geq 2$$

$$\text{wideband CQI}_{\text{SCell1}} - \text{wideband CQI}_{\text{SCell6}} \geq 2$$

for more than 90% of the time.

**Table 9.6.1.1-10: Parameters for PUCCH 1-0 static test on multiple cells (FDD, 7 DL CA)**

Parameter	Unit	Pcell	Scell1	Scell2, 3, 4, 5, 6
PDSCH transmission mode		1		
Downlink power allocation	$\rho_A$	0		
	$\rho_B$	0		
Propagation condition and antenna configuration		AWGN (1 x 2)		
SNR	dB	12	6	0
$\hat{I}_{or}^{(j)}$	dB[mW/15kHz]	-86	-92	-98
$N_{oc}^{(j)}$	dB[mW/15kHz]	-98	-98	-98
Physical channel for CQI reporting		PUCCH Format 2		
PUCCH Report Type		4		
Reporting periodicity	ms	$N_{pd} = 40$		
<i>cqi-pmi-ConfigurationIndex</i>		41	46 (shift of 5 ms relative to Pcell)	51 for Scell 2 (shift of 10 ms relative to Pcell), 56 for Scell 3 (shift of 15ms relative to Pcell), 61 for Scell4 (shift of 20ms relative to Pcell), 66 for Scell5 (shift of 25ms relative to Pcell), 71 for Scell6 (shift of 30ms relative to Pcell)
Note 1:	3 symbols are allocated to PDCCH. No PDSCH for user data is scheduled for the UE with one sided dynamic OCNB Pattern OP.1 FDD as described in Annex A.5.1.1.			
Note 2:	Void			

**Table 9.6.1.1-11: PUCCH 1-0 static test (FDD, 7 DL CA)**

Test number	Bandwidth combination (MHz)
1	7x20
Note 1:	The applicability of requirements for different CA configurations and bandwidth combination sets is defined in 9.1.1.2. The test coverage for different number of component carriers is defined in 9.1.1.3.
Note 2:	If more than one cell can be configured as PCell, choose one of the cells with the smallest bandwidth as PCell. Mapping of PCell and Scells to the CCs shall be constant for all the iterations during the test. Each execution of the test shall use the same mapping.

### 9.6.1.2 TDD

The following requirements apply to UE Category  $\geq 3$ . For CA with 2 DL CC, for the parameters specified in Table 9.6.1.2-1 and Table 9.6.1.2-2, and using the downlink physical channels specified in tables C.3.2-1 and C.3.2-2 on each cell, the difference between the wideband CQI indices of Pcell and Scell reported shall be such that

$$\text{wideband CQI}_{\text{Pcell}} - \text{wideband CQI}_{\text{Scell}} \geq 2$$

for more than 90% of the time.



**Table 9.6.1.2-1: PUCCH 1-0 static test on multiple cells (TDD, 2 DL CA)**

Parameter	Unit	Pcell	Scell
PDSCH transmission mode			1
Uplink downlink configuration			2
Special subframe configuration			4
Downlink power allocation	$\rho_A$	dB	0
	$\rho_B$	dB	0
Propagation condition and antenna configuration		AWGN (1 x 2)	
SNR	dB	10	4
$\hat{I}_{or}^{(j)}$	dB[mW/15kHz]	-88	-94
$N_{oc}^{(j)}$	dB[mW/15kHz]	-98	-98
Physical channel for CQI reporting		PUCCH Format 2	
PUCCH Report Type		4	
Reporting periodicity	ms	$N_{pd} = 10$	
<i>cqi-pmi-ConfigurationIndex</i>		8	13 (shift of 5 ms relative to Pcell)
Note 1:	3 symbols are allocated to PDCCH. No PDSCH for user data is scheduled for the UE with one sided dynamic OCNG Pattern OP.1 TDD as described in Annex A.5.2.1.		
Note 2:	Void		

**Table 9.6.1.2-2: PUCCH 1-0 static test (TDD, 2 DL CA)**

Test number	Bandwidth combination
1	20MHz for both cells
2	15MHz for PCell and 20MHz for SCell
Note 1:	The applicability of requirements for different CA configurations and bandwidth combination sets is defined in 9.1.1.2. The test coverage for different number of component carriers is defined in 9.1.1.3.
Note 2:	Mapping of PCell and Scell to the CCs shall be constant for all the iterations during the test. Each execution of the test shall use the same mapping.

The following requirements for 3DL CA apply to UE Category  $\geq 5$ . For CA with 3 DL CC, for the parameters specified in Table 9.6.1.2-3 and Table 9.6.1.2-4, and using the downlink physical channels specified in tables C.3.2-1 and C.3.2-2 on each cell, the difference between the wideband CQI indices of PCell and SCell1 reported, and the difference between the wideband CQI indices of SCell 1 and SCell2 reported shall be such that

$$\text{wideband CQI}_{\text{PCell}} - \text{wideband CQI}_{\text{SCell1}} \geq 2$$

$$\text{wideband CQI}_{\text{SCell1}} - \text{wideband CQI}_{\text{SCell2}} \geq 2$$

for more than 90% of the time.

The following requirements for 4DL CA apply to UE Category  $\geq 8$ . For CA with 4 DL CC, for the parameters specified in Table 9.6.1.2-3 and Table 9.6.1.2-5, and using the downlink physical channels specified in tables C.3.2-1 and C.3.2-2 on each cell, the difference between the wideband CQI indices of PCell and SCell1 reported, and the difference between the wideband CQI indices of SCell 1 and SCell2, and SCell 1 and SCell 3 reported shall be such that

$$\text{wideband CQI}_{\text{PCell}} - \text{wideband CQI}_{\text{SCell1}} \geq 2$$

$$\text{wideband CQI}_{\text{SCell1}} - \text{wideband CQI}_{\text{SCell2}} \geq 2$$

$$\text{wideband CQI}_{\text{SCell1}} - \text{wideband CQI}_{\text{SCell3}} \geq 2$$

for more than 90% of the time.

**Table 9.6.1.2-3: PUCCH 1-0 static test on multiple cells (TDD, 3 and 4 DL CA)**

Parameter	Unit	Pcell	Scell1	Scell2, 3
PDSCH transmission mode			1	
Uplink downlink configuration			2	
Special subframe configuration			4	
Downlink power allocation	$\rho_A$	dB	0	
	$\rho_B$	dB	0	
Propagation condition and antenna configuration		AWGN (1 x 2)		
SNR	dB	12	6	0
$\hat{I}_{or}^{(j)}$	dB[mW/15kHz]	-86	-92	-98
$N_{oc}^{(j)}$	dB[mW/15kHz]	-98	-98	-98
Physical channel for CQI reporting		PUCCH Format 2		
PUCCH Report Type		4		
Reporting periodicity	ms	$N_{pd} = 20$		
<i>cqi-pmi-ConfigurationIndex</i>		18	23 (shift of 5 ms relative to Pcell)	28 (shift of 10 ms relative to Pcell) , 33 for Scell3 (shift of 15ms relative to Pcell)
Note 1:	3 symbols are allocated to PDCCH. No PDSCH for user data is scheduled for the UE with one sided dynamic OCNG Pattern OP.1 TDD as described in Annex A.5.2.1.			
Note 2:	Void			

**Table 9.6.1.2-4: PUCCH 1-0 static test (TDD, 3 DL CA)**

Test number	Bandwidth combination (MHz)
1	3x20
2	20+20+15
Note 1:	The applicability of requirements for different CA configurations and bandwidth combination sets is defined in 9.1.1.2. The test coverage for different number of component carriers is defined in 9.1.1.3.
Note 2:	If more than one cell can be configured as PCell, choose one of the cells with the smallest bandwidth as PCell. Mapping of PCell and Scells to the CCs shall be constant for all the iterations during the test. Each execution of the test shall use the same mapping.

**Table 9.6.1.2-5: PUCCH 1-0 static test (TDD, 4 DL CA)**

Test number	Bandwidth combination (MHz)
1	4x20
2	20+20+20+15
Note 1:	The applicability of requirements for different CA configurations and bandwidth combination sets is defined in 9.1.1.2. The test coverage for different number of component carriers is defined in 9.1.1.3.
Note 2:	If more than one cell can be configured as PCell, choose one of the cells with the smallest bandwidth as PCell. Mapping of PCell and Scells to the CCs shall be constant for all the iterations during the test. Each execution of the test shall use the same mapping.

The following requirements for 5DL CA apply to UE Category 8 and  $\geq 11$ . For CA with 5 DL CC, for the parameters specified in Table 9.6.1.2-6 and Table 9.6.1.2-7, and using the downlink physical channels specified in tables C.3.2-1

and C.3.2-2 on each cell, the difference between the wideband CQI indices of PCell and SCell1 reported, and the difference between the wideband CQI indices of SCell 1 and SCell2, SCell 1 and SCell 3, and SCell 1 and SCell 4 reported shall be such that

$$\text{wideband CQI}_{\text{PCell}} - \text{wideband CQI}_{\text{SCell1}} \geq [2]$$

$$\text{wideband CQI}_{\text{SCell1}} - \text{wideband CQI}_{\text{SCell2}} \geq [2]$$

$$\text{wideband CQI}_{\text{SCell1}} - \text{wideband CQI}_{\text{SCell3}} \geq [2]$$

$$\text{wideband CQI}_{\text{SCell1}} - \text{wideband CQI}_{\text{SCell4}} \geq [2]$$

for more than 90% of the time.

**Table 9.6.1.2-6: Parameters for PUCCH 1-0 static test on multiple cells (TDD, 5 DL CA)**

Parameter	Unit	Pcell	Scell1	Scell2, 3, 4
PDSCH transmission mode				1
Uplink downlink configuration				2
Special subframe configuration				4
Downlink power allocation	$\rho_A$	dB		0
	$\rho_B$	dB		0
Propagation condition and antenna configuration		AWGN (1 x 2)		
SNR	dB	12	6	0
$\hat{I}_{or}^{(j)}$	dB[mW/15kHz]	-86	-92	-98
$N_{oc}^{(j)}$	dB[mW/15kHz]	-98	-98	-98
Physical channel for CQI reporting		PUCCH Format 2		
PUCCH Report Type		4		
Reporting periodicity	ms	$N_{pd} = 40$		
<i>cqi-pmi-ConfigurationIndex</i>		38	43 (shift of 5 ms relative to Pcell)	48 (shift of 10 ms relative to Pcell), 53 for Scell3 (shift of 15ms relative to Pcell), 58 for Scell4 (shift of 20ms relative to Pcell)
Note 1:	3 symbols are allocated to PDCCH. No PDSCH for user data is scheduled for the UE with one sided dynamic OCN Pattern OP.1 TDD as described in Annex A.5.2.1.			
Note 2:	Void			

**Table 9.6.1.2-7: PUCCH 1-0 static test (TDD, 5 DL CA)**

Test number	Bandwidth combination (MHz)
1	5x20
2	15+4x20
Note 1:	The applicability of requirements for different CA configurations and bandwidth combination sets is defined in 9.1.1.2. The test coverage for different number of component carriers is defined in 9.1.1.3.
Note 2:	If more than one cell can be configured as PCell, choose one of the cells with the smallest bandwidth as PCell. Mapping of PCell and Scells to the CCs shall be constant for all the iterations during the test. Each execution of the test shall use the same mapping.

The following requirements for 6DL CA apply to UE Category 8 and  $\geq 11$ . For CA with 6 DL CC, for the parameters specified in Table 9.6.1.2-8 and Table 9.6.1.2-9, and using the downlink physical channels specified in tables C.3.2-1 and C.3.2-2 on each cell, the difference between the wideband CQI indices of PCell and SCell1 reported, and the

difference between the wideband CQI indices of SCell 1 and SCell2, SCell 1 and SCell 3, SCell 1 and SCell 4, and SCell 1 and SCell 5 reported shall be such that

$$\begin{aligned} \text{wideband CQI}_{\text{Pcell}} - \text{wideband CQI}_{\text{Scell1}} &\geq [2] \\ \text{wideband CQI}_{\text{Scell1}} - \text{wideband CQI}_{\text{Scell2}} &\geq [2] \\ \text{wideband CQI}_{\text{Scell1}} - \text{wideband CQI}_{\text{Scell3}} &\geq [2] \\ \text{wideband CQI}_{\text{Scell1}} - \text{wideband CQI}_{\text{Scell4}} &\geq [2] \\ \text{wideband CQI}_{\text{Scell1}} - \text{wideband CQI}_{\text{Scell5}} &\geq [2] \end{aligned}$$

for more than 90% of the time.

**Table 9.6.1.2-8: Parameters for PUCCH 1-0 static test on multiple cells (TDD, 6 DL CA)**

Parameter	Unit	Pcell	Scell1	Scell2, 3, 4, 5
PDSCH transmission mode		1		
Uplink downlink configuration		2		
Special subframe configuration		4		
Downlink power allocation	$\rho_A$	dB		
	$\rho_B$	dB		
Propagation condition and antenna configuration		AWGN (1 x 2)		
SNR	dB	12	6	0
$\hat{I}_{or}^{(j)}$	dB[mW/15kHz]	-86	-92	-98
$N_{oc}^{(j)}$	dB[mW/15kHz]	-98	-98	-98
Physical channel for CQI reporting		PUCCH Format 2		
PUCCH Report Type		4		
Reporting periodicity	ms	$N_{pd} = 40$		
<i>cqi-pmi-ConfigurationIndex</i>		38	43 (shift of 5 ms relative to Pcell)	48 (shift of 10 ms relative to Pcell), 53 for Scell3 (shift of 15ms relative to Pcell), 58 for Scell4 (shift of 20ms relative to Pcell), 63 for Scell5 (shift of 25ms relative to Pcell)
Note 1:	3 symbols are allocated to PDCCH. No PDSCH for user data is scheduled for the UE with one sided dynamic OCN Pattern OP.1 TDD as described in Annex A.5.2.1.			
Note 2:	Void			

**Table 9.6.1.2-9: PUCCH 1-0 static test (TDD, 6 DL CA)**

Test number	Bandwidth combination (MHz)
1	6x20
Note 1:	The applicability of requirements for different CA configurations and bandwidth combination sets is defined in 9.1.1.2. The test coverage for different number of component carriers is defined in 9.1.1.3.
Note 2:	If more than one cell can be configured as PCell, choose one of the cells with the smallest bandwidth as PCell. Mapping of PCell and Scells to the CCs shall be constant for all the iterations during the test. Each execution of the test shall use the same mapping.

The following requirements for 7DL CA apply to UE Category 8 and  $\geq 11$ . For CA with 7 DL CC, for the parameters specified in Table 9.6.1.2-10 and Table 9.6.1.2-11, and using the downlink physical channels specified in tables C.3.2-1 and C.3.2-2 on each cell, the difference between the wideband CQI indices of PCell and SCell1 reported, and the

difference between the wideband CQI indices of SCell 1 and SCell2, SCell 1 and SCell 3, SCell 1 and SCell 4, SCell 1 and SCell 5, SCell 1 and SCell 6 reported shall be such that

$$\text{wideband CQI}_{\text{Pcell}} - \text{wideband CQI}_{\text{Scell1}} \geq [2]$$

$$\text{wideband CQI}_{\text{Scell1}} - \text{wideband CQI}_{\text{Scell2}} \geq [2]$$

$$\text{wideband CQI}_{\text{Scell1}} - \text{wideband CQI}_{\text{Scell3}} \geq [2]$$

$$\text{wideband CQI}_{\text{Scell1}} - \text{wideband CQI}_{\text{Scell4}} \geq [2]$$

$$\text{wideband CQI}_{\text{Scell1}} - \text{wideband CQI}_{\text{Scell5}} \geq [2]$$

$$\text{wideband CQI}_{\text{Scell1}} - \text{wideband CQI}_{\text{Scell6}} \geq [2]$$

for more than 90% of the time.

**Table 9.6.1.2-10: Parameters for PUCCH 1-0 static test on multiple cells (TDD, 7 DL CA)**

Parameter	Unit	Pcell	Scell1	Scell2, 3, 4, 5, 6
PDSCH transmission mode		1		
Uplink downlink configuration		2		
Special subframe configuration		4		
Downlink power allocation	$\rho_A$	0		
	$\rho_B$	0		
Propagation condition and antenna configuration		AWGN (1 x 2)		
SNR	dB	12	6	0
$\hat{I}_{or}^{(j)}$	dB[mW/15kHz]	-86	-92	-98
$N_{oc}^{(j)}$	dB[mW/15kHz]	-98	-98	-98
Physical channel for CQI reporting		PUCCH Format 2		
PUCCH Report Type		4		
Reporting periodicity	ms	$N_{pd} = 40$		
<i>cqi-pmi-ConfigurationIndex</i>		38	43 (shift of 5 ms relative to Pcell)	48 (shift of 10 ms relative to Pcell), 53 for Scell3 (shift of 15ms relative to Pcell), 58 for Scell4 (shift of 20ms relative to Pcell), 63 for Scell5 (shift of 25ms relative to Pcell), 68 for Scell6 (shift of 30ms relative to Pcell)
Note 1:	3 symbols are allocated to PDCCH. No PDSCH for user data is scheduled for the UE with one sided dynamic OCN Pattern OP.1 TDD as described in Annex A.5.2.1.			
Note 2:	Void			

**Table 9.6.1.2-11: PUCCH 1-0 static test (TDD, 7 DL CA)**

Test number	Bandwidth combination (MHz)
1	7x20
Note 1:	The applicability of requirements for different CA configurations and bandwidth combination sets is defined in 9.1.1.2. The test coverage for different number of component carriers is defined in 9.1.1.3.
Note 2:	If more than one cell can be configured as PCell, choose one of the cells with the smallest bandwidth as PCell. Mapping of PCell and Scells to the CCs shall be constant for all the iterations during the test. Each execution of the test shall use the same mapping.

### 9.6.1.3 TDD-FDD CA with FDD PCell

The following requirements apply to UE Category  $\geq 5$ . For TDD-FDD CA with FDD PCell with 2 DL CC, for the parameters specified in Table 9.6.1.3-1 and Table 9.6.1.3-2, and using the downlink physical channels specified in tables C.3.2-1 and C.3.2-2 on each cell, the difference between the wideband CQI indices of PCell and SCell reported shall be such that

$$\text{wideband CQI}_{\text{PCell}} - \text{wideband CQI}_{\text{SCell}} \geq 2$$

for more than 90% of the time.

**Table 9.6.1.3-1: Parameters for PUCCH 1-0 static test on multiple cells (TDD-FDD CA with FDD PCell, 2 DL CA)**

Parameter	Unit	PCell	SCell
PDSCH transmission mode			1
Uplink downlink configuration		N/A	2
Special subframe configuration		N/A	4
Downlink power allocation	$\rho_A$	dB	0
	$\rho_B$	dB	0
Propagation condition and antenna configuration		AWGN (1 x 2)	
SNR	dB	10	4
$\hat{I}_{ar}^{(j)}$	dB[mW/15kHz]	-88	-94
$N_{oc}^{(j)}$	dB[mW/15kHz]	-98	-98
Physical channel for CQI reporting		PUCCH Format 2	
PUCCH Report Type		4	
Reporting periodicity	ms	$N_{pd} = 10$	
<i>cqi-pmi-ConfigurationIndex</i>		9	14 (shift of 5 ms relative to Pcell)
Note 1:	3 symbols are allocated to PDCCH. No PDSCH for user data is scheduled for the UE with one sided dynamic OCNG Pattern OP.1 FDD and OP.1 TDD as described in Annex A.5.1.1 and A.5.2.1.		
Note 2:	Void		
Note 3:	Void		

**Table 9.6.1.3-2: PUCCH 1-0 static test (TDD-FDD CA with FDD PCell, 2 DL CA)**

Test number	Bandwidth combination
1	20MHz for FDD cell and 20MHz for TDD cell
2	10MHz for FDD cell and 20MHz for TDD cell
3	15MHz for FDD cell and 20MHz for TDD cell
Note 1:	The applicability of requirements for different CA configurations and bandwidth combination sets is defined in 9.1.1.2A. The test coverage for different number of component carriers is defined in 9.1.1.3.

The following requirements for 3DL CA apply to UE Category  $\geq 5$ . For TDD-FDD CA with FDD PCell with 3 DL CC, for the parameters specified in Table 9.6.1.3-3 and Table 9.6.1.3-4, and using the downlink physical channels specified in tables C.3.2-1 and C.3.2-2 on each cell, the difference between the wideband CQI indices of PCell and SCell1 reported, and the difference between the wideband CQI indices of SCell1 and SCell2 reported shall be such that

$$\text{wideband CQI}_{\text{PCell}} - \text{wideband CQI}_{\text{SCell1}} \geq 2$$

$$\text{wideband CQI}_{\text{SCell1}} - \text{wideband CQI}_{\text{SCell2}} \geq 2$$

for more than 90% of the time.

The following requirements for 4DL CA apply to UE Category  $\geq 8$ . For TDD-FDD CA with FDD PCell with 4 DL CC, for the parameters specified in Table 9.6.1.3-3 and Table 9.6.1.3-5, and using the downlink physical channels specified

in tables C.3.2-1 and C.3.2-2 on each cell, the difference between the wideband CQI indices of PCell and SCell1 reported, and the difference between the wideband CQI indices of SCell1 and SCell2, and SCell1 and SCell3 reported shall be such that

$$\text{wideband CQI}_{\text{PCell}} - \text{wideband CQI}_{\text{SCell1}} \geq 2$$

$$\text{wideband CQI}_{\text{SCell1}} - \text{wideband CQI}_{\text{SCell2}} \geq 2$$

$$\text{wideband CQI}_{\text{SCell1}} - \text{wideband CQI}_{\text{SCell3}} \geq 2$$

for more than 90% of the time.

**Table 9.6.1.3-3: PUCCH 1-0 static test on multiple cells (TDD-FDD CA with FDD PCell, 3 and 4 DL CA)**

Parameter	Unit	PCell	SCell1	SCell2, SCell3
PDSCH transmission mode			1	
Uplink downlink configuration		N/A	2 for TDD Cell N/A for FDD Cell	
Special subframe configuration		N/A	4 for TDD Cell N/A for FDD Cell	
Downlink power allocation	$\rho_A$	dB	0	
	$\rho_B$	dB	0	
Propagation condition and antenna configuration		AWGN (1 x 2)		
SNR	dB	12	6	0
$\hat{I}_{or}^{(j)}$	dB[mW/15kHz]	-86	-92	-98
$N_{oc}^{(j)}$	dB[mW/15kHz]	-98	-98	-98
Physical channel for CQI reporting		PUCCH Format 2		
PUCCH Report Type		4		
Reporting periodicity	ms	$N_{pd} = 20$		
<i>cqi-pmi-ConfigurationIndex</i>		19	24 (shift of 5 ms relative to Pcell)	29 for SCell 2 (shift of 10 ms relative to Pcell) , 34 for SCell 3 (shift of 15ms relative to PCell)
Note 1:	3 symbols are allocated to PDCCH. No PDSCH for user data is scheduled for the UE with one sided dynamic OCNG Pattern OP.1 FDD and OP.1 TDD as described in Annex A.5.1.1 and A.5.2.1.			
Note 2:	Void			
Note 3:	Void			

**Table 9.6.1.3-4: PUCCH 1-0 static test (TDD-FDD CA with FDD PCell, 3 DL CA)**

Test number	Bandwidth combination (MHz)
1	20MHz for FDD cell and 2x20MHz for TDD cell
2	15MHz for FDD cell and 2x20MHz for TDD cell
3	10MHz for FDD cell and 2x20MHz for TDD cell
4	2x20MHz for FDD cell and 20MHz for TDD cell
5	20+15MHz for FDD cell and 20MHz for TDD cell
6	20+10MHz for FDD cell and 20MHz for TDD cell
7	2x10MHz for FDD cell and 20MHz for TDD cell
8	10MHz for FDD cell and 15+20MHz for TDD cell
9	10+15MHz for FDD cell and 20MHz for TDD cell
Note 1:	The applicability of requirements for different CA configurations and bandwidth combination sets is defined in 9.1.1.2A. The test coverage for different number of component carriers is defined in 9.1.1.3.
Note 2:	If more than one cell can be configured as PCell, choose one of the cells with the smallest bandwidth as PCell. Mapping of PCell and Scells to the CCs shall be constant for all the iterations during the test. Each execution of the test shall use the same mapping.

Table 9.6.1.3-5: PUCCH 1-0 static test (TDD-FDD CA with FDD PCell, 4 DL CA)

Test number	Bandwidth combination (MHz)
1	20MHz for FDD cell and 3x20MHz for TDD cell
2	2x20MHz for FDD cell and 2x20MHz for TDD cell
3	20+15MHz for FDD cell and 2x20MHz for TDD cell
4	2x15MHz for FDD cell and 2x20MHz for TDD cell
5	2x20+15MHz for FDD cell and 20MHz for TDD cell
6	2x15+20MHz for FDD cell and 20MHz for TDD cell
7	2x20+10MHz for FDD cell and 20MHz for TDD cell
8	3x20MHz for FDD cell and 20MHz for TDD cell
9	10MHz for FDD cell and 3x20MHz for TDD cell
10	2x10MHz for FDD cell and 2x20MHz for TDD cell
11	2x10MHz for FDD cell and 20+15MHz for TDD cell
12	10+20MHz for FDD cell and 2x20MHz for TDD cell
13	10+15MHz for FDD cell and 2x20MHz for TDD cell
14	10+15+20MHz for FDD cell and 20MHz for TDD cell
Note 1:	The applicability of requirements for different CA configurations and bandwidth combination sets is defined in 9.1.1.2A. The test coverage for different number of component carriers is defined in 9.1.1.3.
Note 2:	If more than one cell can be configured as PCell, choose one of the cells with the smallest bandwidth as PCell. Mapping of PCell and SCells to the CCs shall be constant for all the iterations during the test. Each execution of the test shall use the same mapping.

The following requirements for 5DL CA apply to UE Category 8 and  $\geq 11$ . For TDD-FDD CA with FDD PCell with 5 DL CC, for the parameters specified in Table 9.6.1.3-6 and Table 9.6.1.3-7, and using the downlink physical channels specified in tables C.3.2-1 and C.3.2-2 on each cell, the difference between the wideband CQI indices of PCell and SCell1 reported, and the difference between the wideband CQI indices of SCell1 and SCell2, SCell1 and SCell3, and SCell 1 and SCell 4 reported shall be such that

$$\text{wideband CQI}_{\text{PCell}} - \text{wideband CQI}_{\text{SCell1}} \geq 2$$

$$\text{wideband CQI}_{\text{SCell1}} - \text{wideband CQI}_{\text{SCell2}} \geq 2$$

$$\text{wideband CQI}_{\text{SCell1}} - \text{wideband CQI}_{\text{SCell3}} \geq 2$$

$$\text{wideband CQI}_{\text{SCell1}} - \text{wideband CQI}_{\text{SCell4}} \geq 2$$

for more than 90% of the time.



**Table 9.6.1.3-6: PUCCH 1-0 static test on multiple cells (TDD-FDD CA with FDD PCell, 5 DL CA)**

Parameter	Unit	PCell	SCell1	SCell2, SCell3, SCell4
PDSCH transmission mode				1
Uplink downlink configuration		N/A		2 for TDD Cell N/A for FDD Cell
Special subframe configuration		N/A		4 for TDD Cell N/A for FDD Cell
Downlink power allocation	$\rho_A$	dB		0
	$\rho_B$	dB		0
Propagation condition and antenna configuration				AWGN (1 x 2)
SNR	dB	12	6	0
$\hat{I}_{or}^{(j)}$	dB[mW/15kHz]	-86	-92	-98
$N_{oc}^{(j)}$	dB[mW/15kHz]	-98	-98	-98
Physical channel for CQI reporting				PUCCH Format 2
PUCCH Report Type				4
Reporting periodicity	ms			$N_{pd} = 40$
<i>cqi-pmi-ConfigurationIndex</i>		39	44 (shift of 5 ms relative to Pcell)	49 for SCell 2 (shift of 10 ms relative to Pcell), 54 for SCell 3 (shift of 15 ms relative to Pcell), 59 for SCell 4 (shift of 20 ms relative to Pcell)
Note 1:	3 symbols are allocated to PDCCH. No PDSCH for user data is scheduled for the UE with one sided dynamic OCNG Pattern OP.1 FDD and OP.1 TDD as described in Annex A.5.1.1 and A.5.2.1.			
Note 2:	Void			
Note 3:	Void			

**Table 9.6.1.3-7: PUCCH 1-0 static test (TDD-FDD CA with FDD PCell, 5 DL CA)**

Test number	Bandwidth combination (MHz)
1	15MHz+2x20MHz for FDD cell and 2x20MHz for TDD cell
2	2x15MHz+20MHz for FDD cell and 2x20MHz for TDD cell
3	4x20(FDD)+20(TDD)MHz
4	3x20(FDD)+2x20(TDD)MHz
5	2x20(FDD)+3x20(TDD)MHz
6	20(FDD)+4x20(TDD)MHz
7	10(FDD)+4x20(TDD)MHz
8	2x10(FDD)+3x20(TDD)MHz
9	10+20(FDD)+3x20(TDD)MHz
10	10+2x20(FDD)+2x20(TDD)MHz
11	10+15+20(FDD)+2x20(TDD)MHz
Note 1:	The applicability of requirements for different CA configurations and bandwidth combination sets is defined in 9.1.1.2A. The test coverage for different number of component carriers is defined in 9.1.1.3.
Note 2:	If more than one cell can be configured as PCell, choose one of the cells with the smallest bandwidth as PCell. Mapping of PCell and SCells to the CCs shall be constant for all the iterations during the test. Each execution of the test shall use the same mapping.

The following requirements for 6DL CA apply to UE Category 8 and  $\geq 11$ . For TDD-FDD CA with FDD PCell with 6 DL CC, for the parameters specified in Table 9.6.1.3-8 and Table 9.6.1.3-9, and using the downlink physical channels specified in tables C.3.2-1 and C.3.2-2 on each cell, the difference between the wideband CQI indices of PCell and SCell1 reported, and the difference between the wideband CQI indices of SCell1 and SCell2, SCell1 and SCell3, SCell 1 and SCell 4, and SCell 1 and SCell 5 reported shall be such that

$$\text{wideband CQI}_{\text{PCell}} - \text{wideband CQI}_{\text{SCell1}} \geq 2$$

$$\text{wideband CQI}_{\text{SCell1}} - \text{wideband CQI}_{\text{SCell2}} \geq 2$$

$$\text{wideband CQI}_{\text{SCell1}} - \text{wideband CQI}_{\text{SCell3}} \geq 2$$

wideband  $CQI_{SCell1} - \text{wideband } CQI_{SCell4} \geq 2$

wideband  $CQI_{SCell1} - \text{wideband } CQI_{SCell5} \geq 2$

for more than 90% of the time.

**Table 9.6.1.3-8: PUCCH 1-0 static test on multiple cells (TDD-FDD CA with FDD PCell, 6 DL CA)**

Parameter	Unit	PCell	SCell1	SCell2, SCell3, SCell4, SCell5
PDSCH transmission mode			1	
Uplink downlink configuration		N/A	2 for TDD Cell N/A for FDD Cell	
Special subframe configuration		N/A	4 for TDD Cell N/A for FDD Cell	
Downlink power allocation	$\rho_A$	dB	0	
	$\rho_B$	dB	0	
Propagation condition and antenna configuration		AWGN (1 x 2)		
SNR	dB	12	6	0
$\hat{I}_{or}^{(j)}$	dB[mW/15kHz]	-86	-92	-98
$N_{oc}^{(j)}$	dB[mW/15kHz]	-98	-98	-98
Physical channel for CQI reporting		PUCCH Format 2		
PUCCH Report Type		4		
Reporting periodicity	ms	$N_{pd} = 40$		
<i>cqi-pmi-ConfigurationIndex</i>		39	44 (shift of 5 ms relative to Pcell)	49 for SCell 2 (shift of 10 ms relative to Pcell), 54 for SCell 3 (shift of 15 ms relative to Pcell), 59 for SCell 4 (shift of 20 ms relative to Pcell), 64 for SCell 5 (shift of 25 ms relative to Pcell)
Note 1:	3 symbols are allocated to PDCCH. No PDSCH for user data is scheduled for the UE with one sided dynamic OCNG Pattern OP.1 FDD and OP.1 TDD as described in Annex A.5.1.1 and A.5.2.1.			
Note 2:	Void			
Note 3:	Void			

**Table 9.6.1.3-9: PUCCH 1-0 static test (TDD-FDD CA with FDD PCell, 6 DL CA)**

Test number	Bandwidth combination (MHz)
1	1x20(FDD)+5x20(TDD)
2	2x20(FDD)+4x20(TDD)
Note 1:	The applicability of requirements for different CA configurations and bandwidth combination sets is defined in 9.1.1.2A. The test coverage for different number of component carriers is defined in 9.1.1.3.
Note 2:	If more than one cell can be configured as PCell, choose one of the cells with the smallest bandwidth as PCell. Mapping of PCell and Scells to the CCs shall be constant for all the iterations during the test. Each execution of the test shall use the same mapping.

The following requirements for 7DL CA apply to UE Category 8 and  $\geq 11$ . For TDD-FDD CA with FDD PCell with 7 DL CC, for the parameters specified in Table 9.6.1.3-10 and Table 9.6.1.3-11, and using the downlink physical channels specified in tables C.3.2-1 and C.3.2-2 on each cell, the difference between the wideband CQI indices of PCell and SCell1 reported, and the difference between the wideband CQI indices of SCell1 and SCell2, SCell1 and SCell3, SCell 1 and SCell 4, SCell 1 and SCell 5, SCell 1 and SCell 6 reported shall be such that

wideband  $CQI_{PCell} - \text{wideband } CQI_{SCell1} \geq 2$

wideband  $CQI_{SCell1} - \text{wideband } CQI_{SCell2} \geq 2$

wideband  $CQI_{SCell1} - \text{wideband } CQI_{SCell3} \geq 2$

wideband  $CQI_{SCell1} - \text{wideband } CQI_{SCell4} \geq 2$

wideband  $CQI_{SCell1} - \text{wideband } CQI_{SCell5} \geq 2$

wideband  $CQI_{SCell1} - \text{wideband } CQI_{SCell6} \geq 2$

for more than 90% of the time.

**Table 9.6.1.3-10: PUCCH 1-0 static test on multiple cells (TDD-FDD CA with FDD PCell, 7 DL CA)**

Parameter	Unit	PCell	SCell1	SCell2, SCell3, SCell4, SCell5, SCell6
PDSCH transmission mode			1	
Uplink downlink configuration		N/A	2 for TDD Cell N/A for FDD Cell	
Special subframe configuration		N/A	4 for TDD Cell N/A for FDD Cell	
Downlink power allocation	$\rho_A$	dB	0	
	$\rho_B$	dB	0	
Propagation condition and antenna configuration		AWGN (1 x 2)		
SNR	dB	12	6	0
$\hat{I}_{or}^{(j)}$	dB[mW/15kHz]	-86	-92	-98
$N_{oc}^{(j)}$	dB[mW/15kHz]	-98	-98	-98
Physical channel for CQI reporting		PUCCH Format 2		
PUCCH Report Type		4		
Reporting periodicity	ms	$N_{pd} = 40$		
<i>cqi-pmi-ConfigurationIndex</i>		39	44 (shift of 5 ms relative to Pcell)	49 for SCell 2 (shift of 10 ms relative to Pcell), 54 for SCell 3 (shift of 15 ms relative to Pcell), 59 for SCell 4 (shift of 20 ms relative to Pcell), 64 for SCell 5 (shift of 25 ms relative to Pcell), 69 for SCell 6 (shift of 30 ms relative to Pcell)
Note 1:	3 symbols are allocated to PDCCH. No PDSCH for user data is scheduled for the UE with one sided dynamic OCNG Pattern OP.1 FDD and OP.1 TDD as described in Annex A.5.1.1 and A.5.2.1.			
Note 2:	Void			
Note 3:	Void			

**Table 9.6.1.3-11: PUCCH 1-0 static test (TDD-FDD CA with FDD PCell, 7 DL CA)**

Test number	Bandwidth combination (MHz)
1	1x20(FDD)+6x20(TDD)
2	2x20(FDD)+5x20(TDD)
Note 1:	The applicability of requirements for different CA configurations and bandwidth combination sets is defined in 9.1.1.2A. The test coverage for different number of component carriers is defined in 9.1.1.3.
Note 2:	If more than one cell can be configured as PCell, choose one of the cells with the smallest bandwidth as PCell. Mapping of PCell and Scells to the CCs shall be constant for all the iterations during the test. Each execution of the test shall use the same mapping.

#### 9.6.1.4 TDD-FDD CA with TDD PCell

The following requirements apply to UE Category  $\geq 5$ . For TDD-FDD CA with TDD PCell with 2 DL CC, for the parameters specified in Table 9.6.1.4-1 and Table 9.6.1.4-2, and using the downlink physical channels specified in tables C.3.2-1 and C.3.2-2 on each cell, the difference between the wideband CQI indices of PCell and SCell reported shall be such that

$$\text{wideband CQI}_{\text{PCell}} - \text{wideband CQI}_{\text{SCell}} \geq 2$$

for more than 90% of the time.

**Table 9.6.1.4-1: Parameters for PUCCH 1-0 static test on multiple cells (TDD-FDD CA with TDD PCell, 2 DL CA)**

Parameter	Unit	PCell	SCell
PDSCH transmission mode		1	
Uplink downlink configuration		2	N/A
Special subframe configuration		4	N/A
Downlink power allocation	$\rho_A$	dB	
	$\rho_B$	dB	
Propagation condition and antenna configuration		AWGN (1 x 2)	
SNR	dB	10	4
$\hat{I}_{or}^{(j)}$	dB[mW/15kHz]	-88	-94
$N_{oc}^{(j)}$	dB[mW/15kHz]	-98	-98
Physical channel for CQI reporting		PUCCH Format 2	
PUCCH Report Type		4	
Reporting periodicity	ms	$N_{pd} = 10$	
<i>cqi-pmi-ConfigurationIndex</i>		8	13 (shift of 5 ms relative to PCell)
Note 1:	3 symbols are allocated to PDCCH. No PDSCH for user data is scheduled for the UE with one sided dynamic OCNG Pattern OP.1 FDD and OP.1 TDD as described in Annex A.5.1.1 and A.5.2.1.		
Note 2:	Void		
Note 3:	Void		

**Table 9.6.1.4-2: PUCCH 1-0 static test (TDD-FDD CA with TDD PCell, 2 DL CA)**

Test number	Bandwidth combination
1	20MHz for TDD cell and 20MHz for FDD cell
2	20MHz for TDD cell and 10MHz for FDD cell
3	20MHz for TDD cell and 15MHz for FDD cell
Note 1:	The applicability of requirements for different CA configurations and bandwidth combination sets is defined in 9.1.1.2A. The test coverage for different number of component carriers is defined in 9.1.1.3.

The following requirements for 3DL CA apply to UE Category  $\geq 5$ . For TDD-FDD CA with TDD PCell with 3 DL CC, for the parameters specified in Table 9.6.1.4-3 and Table 9.6.1.4-4, and using the downlink physical channels specified in tables C.3.2-1 and C.3.2-2 on each cell, the difference between the wideband CQI indices of PCell and SCell1 reported, and the difference between the wideband CQI indices of SCell1 and SCell2 reported shall be such that

$$\text{wideband CQI}_{\text{PCell}} - \text{wideband CQI}_{\text{SCell1}} \geq 2$$

$$\text{wideband CQI}_{\text{SCell1}} - \text{wideband CQI}_{\text{SCell2}} \geq 2$$

for more than 90% of the time.

The following requirements for 4DL CA apply to UE Category  $\geq 8$ . For TDD-FDD CA with TDD PCell with 4 DL CC, for the parameters specified in Table 9.6.1.4-3 and Table 9.6.1.4-5, and using the downlink physical channels specified in tables C.3.2-1 and C.3.2-2 on each cell, the difference between the wideband CQI indices of PCell and SCell1 reported, and the difference between the wideband CQI indices of SCell1 and SCell2, and SCell1 and SCell3 reported shall be such that

$$\text{wideband CQI}_{\text{PCell}} - \text{wideband CQI}_{\text{SCell1}} \geq 2$$

$$\text{wideband CQI}_{\text{SCell1}} - \text{wideband CQI}_{\text{SCell2}} \geq 2$$

wideband  $CQI_{SCell1} - \text{wideband } CQI_{SCell3} \geq 2$

for more than 90% of the time.

**Table 9.6.1.4-3: PUCCH 1-0 static test on multiple cells (TDD-FDD CA with TDD PCell, 3 and 4 DL CA)**

Parameter	Unit	PCell	SCell1	SCell2, SCell3
PDSCH transmission mode			1	
Uplink downlink configuration		2	2 for TDD Cell N/A for FDD Cell	
Special subframe configuration		4	4 for TDD Cell N/A for FDD Cell	
Downlink power allocation	$\rho_A$	dB	0	
	$\rho_B$	dB	0	
Propagation condition and antenna configuration		AWGN (1 x 2)		
SNR	dB	12	6	0
$\hat{I}_{or}^{(j)}$	dB[mW/15kHz]	-86	-92	-98
$N_{oc}^{(j)}$	dB[mW/15kHz]	-98	-98	-98
Physical channel for CQI reporting		PUCCH Format 2		
PUCCH Report Type		4		
Reporting periodicity	ms	$N_{pd} = 20$		
<i>cqi-pmi-ConfigurationIndex</i>		18	23 (shift of 5 ms relative to Pcell)	28 for SCell 2 (shift of 10 ms relative to Pcell) , 33 for SCell 3 (shift of 15ms relative to PCell)
Note 1:	3 symbols are allocated to PDCCH. No PDSCH for user data is scheduled for the UE with one sided dynamic OCNG Pattern OP.1 FDD and OP.1 TDD as described in Annex A.5.1.1 and A.5.2.1.			
Note 2:	Void			
Note 3:	Void			

**Table 9.6.1.4-4: PUCCH 1-0 static test (TDD-FDD CA with TDD PCell, 3 DL CA)**

Test number	Bandwidth combination (MHz)
1	2x20MHz for TDD cell and 20MHz for FDD cell
2	2x20MHz for TDD cell and 15MHz for FDD cell
3	2x20MHz for TDD cell and 10MHz for FDD cell
4	2x20MHz for FDD cell and 20MHz for TDD cell
5	20+15MHz for FDD cell and 20MHz for TDD cell
6	20+10MHz for FDD cell and 20MHz for TDD cell
7	2x10MHz for FDD cell and 20MHz for TDD cell
8	10MHz for FDD cell and 15+20MHz for TDD cell
9	10+15MHz for FDD cell and 20MHz for TDD cell
Note 1:	The applicability of requirements for different CA configurations and bandwidth combination sets is defined in 9.1.1.2A. The test coverage for different number of component carriers is defined in 9.1.1.3.
Note 2:	If more than one cell can be configured as PCell, choose one of the cells with the smallest bandwidth as PCell. Mapping of PCell and Scells to the CCs shall be constant for all the iterations during the test. Each execution of the test shall use the same mapping.

**Table 9.6.1.4-5: PUCCH 1-0 static test (TDD-FDD CA with TDD PCell, 4 DL CA)**

Test number	Bandwidth combination (MHz)
1	3x20MHz for TDD cell and 20MHz for FDD cell
2	2x20MHz for FDD cell and 2x20MHz for TDD cell
3	20+15MHz for FDD cell and 2x20MHz for TDD cell
4	2x15MHz for FDD cell and 2x20MHz for TDD cell
5	2x20+15MHz for FDD cell and 20MHz for TDD cell
6	2x15+20MHz for FDD cell and 20MHz for TDD cell
7	2x20+10MHz for FDD cell and 20MHz for TDD cell
8	3x20MHz for FDD cell and 20MHz for TDD cell
9	10MHz for FDD cell and 3x20MHz for TDD cell
10	2x10MHz for FDD cell and 2x20MHz for TDD cell
11	2x10MHz for FDD cell and 20+15MHz for TDD cell
12	10+20MHz for FDD cell and 2x20MHz for TDD cell
13	10+15MHz for FDD cell and 2x20MHz for TDD cell
14	10+15+20MHz for FDD cell and 20MHz for TDD cell
Note 1:	The applicability of requirements for different CA configurations and bandwidth combination sets is defined in 9.1.1.2A. The test coverage for different number of component carriers is defined in 9.1.1.3.
Note 2:	If more than one cell can be configured as PCell, choose one of the cells with the smallest bandwidth as PCell. Mapping of PCell and SCells to the CCs shall be constant for all the iterations during the test. Each execution of the test shall use the same mapping.

The following requirements for 5DL CA apply to UE Category 8 and  $\geq 11$ . For TDD-FDD CA with TDD PCell with 5 DL CC, for the parameters specified in Table 9.6.1.4-6 and Table 9.6.1.4-7, and using the downlink physical channels specified in tables C.3.2-1 and C.3.2-2 on each cell, the difference between the wideband CQI indices of PCell and SCell1 reported, and the difference between the wideband CQI indices of SCell1 and SCell2, SCell1 and SCell3 and SCell 1 and SCell 4 reported shall be such that

$$\text{wideband CQI}_{\text{PCell}} - \text{wideband CQI}_{\text{SCell1}} \geq 2$$

$$\text{wideband CQI}_{\text{SCell1}} - \text{wideband CQI}_{\text{SCell2}} \geq 2$$

$$\text{wideband CQI}_{\text{SCell1}} - \text{wideband CQI}_{\text{SCell3}} \geq 2$$

$$\text{wideband CQI}_{\text{SCell1}} - \text{wideband CQI}_{\text{SCell4}} \geq 2$$

for more than 90% of the time.

**Table 9.6.1.4-6: PUCCH 1-0 static test on multiple cells (TDD-FDD CA with TDD PCell, 5 DL CA)**

Parameter	Unit	PCell	SCell1	SCell2, SCell3, SCell4
PDSCH transmission mode				1
Uplink downlink configuration		2		2 if SCell1 is TDD Cell N/A if SCell1 is FDD Cell
Special subframe configuration		4		4 if SCell1 is TDD Cell N/A if SCell1 is FDD Cell
Downlink power allocation	$\rho_A$	dB		0
	$\rho_B$	dB		0
Propagation condition and antenna configuration				AWGN (1 x 2)
SNR	dB	12	6	0
$\hat{I}_{or}^{(j)}$	dB[mW/15kHz]	-86	-92	-98
$N_{oc}^{(j)}$	dB[mW/15kHz]	-98	-98	-98
Physical channel for CQI reporting				PUCCH Format 2
PUCCH Report Type				4
Reporting periodicity	ms			$N_{pd} = 40$
<i>cqi-pmi-ConfigurationIndex</i>		38	43 (shift of 5 ms relative to Pcell)	48 for SCell 2 (shift of 10 ms relative to Pcell), 53 for SCell 3 (shift of 15 ms relative to Pcell), 58 for SCell 4 (shift of 20 ms relative to Pcell)
Note 1:	3 symbols are allocated to PDCCH. No PDSCH for user data is scheduled for the UE with one sided dynamic OCNG Pattern OP.1 FDD and OP.1 TDD as described in Annex A.5.1.1 and A.5.2.1.			
Note 2:	Void			
Note 3:	Void			

**Table 9.6.1.4-7: PUCCH 1-0 static test (TDD-FDD CA with TDD PCell, 5 DL CA)**

Test number	Bandwidth combination (MHz)
1	15MHz+2x20MHz for FDD cell and 2x20MHz for TDD cell
2	2x15MHz+20MHz for FDD cell and 2x20MHz for TDD cell
3	4x20(FDD)+20(TDD)MHz
4	3x20(FDD)+2x20(TDD)MHz
5	2x20(FDD)+3x20(TDD)N/A
6	20(FDD)+4x20(TDD)MHz
7	10(FDD)+4x20(TDD)MHz
8	2x10(FDD)+3x20(TDD)MH
9	10+20(FDD)+3x20(TDD)MHz
10	10+2x20(FDD)+2x20(TDD)MHz
11	10+15+20(FDD)+2x20(TDD)MHz
Note 1:	The applicability of requirements for different CA configurations and bandwidth combination sets is defined in 9.1.1.2A. The test coverage for different number of component carriers is defined in 9.1.1.3.
Note 2:	If more than one cell can be configured as PCell, choose one of the cells with the smallest bandwidth as PCell. Mapping of PCell and SCells to the CCs shall be constant for all the iterations during the test. Each execution of the test shall use the same mapping.

The following requirements for 6DL CA apply to UE Category 8 and  $\geq 11$ . For TDD-FDD CA with TDD PCell with 6 DL CC, for the parameters specified in Table 9.6.1.4-8 and Table 9.6.1.4-9, and using the downlink physical channels specified in tables C.3.2-1 and C.3.2-2 on each cell, the difference between the wideband CQI indices of PCell and SCell1 reported, and the difference between the wideband CQI indices of SCell1 and SCell2, SCell1 and SCell3, SCell1 and SCell4, and SCell1 and SCell5 reported shall be such that

$$\text{wideband CQI}_{\text{PCell}} - \text{wideband CQI}_{\text{SCell1}} \geq 2$$

$$\text{wideband CQI}_{\text{SCell1}} - \text{wideband CQI}_{\text{SCell2}} \geq 2$$

$$\text{wideband CQI}_{\text{SCell1}} - \text{wideband CQI}_{\text{SCell3}} \geq 2$$

wideband  $CQI_{SCell1} - \text{wideband } CQI_{SCell4} \geq 2$

wideband  $CQI_{SCell1} - \text{wideband } CQI_{SCell5} \geq 2$

for more than 90% of the time.

**Table 9.6.1.4-8: PUCCH 1-0 static test on multiple cells (TDD-FDD CA with TDD PCell, 6 DL CA)**

Parameter	Unit	PCell	SCell1	SCell2, SCell3, SCell4, SCell5
PDSCH transmission mode			1	
Uplink downlink configuration		2	2 if SCell1 is TDD Cell N/A if SCell1 is FDD Cell	
Special subframe configuration		4	4 if SCell1 is TDD Cell N/A if SCell1 is FDD Cell	
Downlink power allocation	$\rho_A$	dB	0	
	$\rho_B$	dB	0	
Propagation condition and antenna configuration		AWGN (1 x 2)		
SNR	dB	12	6	0
$\hat{I}_{or}^{(j)}$	dB[mW/15kHz]	-86	-92	-98
$N_{oc}^{(j)}$	dB[mW/15kHz]	-98	-98	-98
Physical channel for CQI reporting		PUCCH Format 2		
PUCCH Report Type		4		
Reporting periodicity	ms	$N_{pd} = 40$		
<i>cqi-pmi-ConfigurationIndex</i>		38	43 (shift of 5 ms relative to Pcell)	48 for SCell 2 (shift of 10 ms relative to Pcell), 53 for SCell 3 (shift of 15 ms relative to Pcell), 58 for SCell 4 (shift of 20 ms relative to Pcell), 63 for SCell 5 (shift of 25 ms relative to Pcell)
Note 1:	3 symbols are allocated to PDCCH. No PDSCH for user data is scheduled for the UE with one sided dynamic OCNG Pattern OP.1 FDD and OP.1 TDD as described in Annex A.5.1.1 and A.5.2.1.			
Note 2:	Void			
Note 3:	Void			

**Table 9.6.1.4-9: PUCCH 1-0 static test (TDD-FDD CA with TDD PCell, 6 DL CA)**

Test number	Bandwidth combination (MHz)
1	1x20(FDD)+ 5x20(TDD)MHz
2	2x20(FDD)+4x20(TDD)MHz
Note 1:	The applicability of requirements for different CA configurations and bandwidth combination sets is defined in 9.1.1.2A. The test coverage for different number of component carriers is defined in 9.1.1.3.
Note 2:	If more than one cell can be configured as PCell, choose one of the cells with the smallest bandwidth as PCell. Mapping of PCell and Scells to the CCs shall be constant for all the iterations during the test. Each execution of the test shall use the same mapping.

The following requirements for 7DL CA apply to UE Category 8 and  $\geq 11$ . For TDD-FDD CA with TDD PCell with 7 DL CC, for the parameters specified in Table 9.6.1.4-10 and Table 9.6.1.4-11, and using the downlink physical channels specified in tables C.3.2-1 and C.3.2-2 on each cell, the difference between the wideband CQI indices of PCell and SCell1 reported, and the difference between the wideband CQI indices of SCell1 and SCell2, SCell1 and SCell3, SCell1 and SCell4, SCell1 and SCell5, and SCell1 and SCell6 reported shall be such that

wideband  $CQI_{PCell} - \text{wideband } CQI_{SCell1} \geq 2$

wideband  $CQI_{SCell1} - \text{wideband } CQI_{SCell2} \geq 2$

wideband  $CQI_{SCell1} - \text{wideband } CQI_{SCell3} \geq 2$



wideband  $CQI_{SCell1}$  – wideband  $CQI_{SCell4} \geq 2$

wideband  $CQI_{SCell1}$  – wideband  $CQI_{SCell5} \geq 2$

wideband  $CQI_{SCell1}$  – wideband  $CQI_{SCell6} \geq 2$

for more than 90% of the time.

**Table 9.6.1.4-10: PUCCH 1-0 static test on multiple cells (TDD-FDD CA with TDD PCell, 7 DL CA)**

Parameter	Unit	PCell	SCell1	SCell2, SCell3, SCell4, SCell5
PDSCH transmission mode			1	
Uplink downlink configuration		2	2 if SCell1 is TDD Cell N/A if SCell1 is FDD Cell	
Special subframe configuration		4	4 if SCell1 is TDD Cell N/A if SCell1 is FDD Cell	
Downlink power allocation	$\rho_A$	dB	0	
	$\rho_B$	dB	0	
Propagation condition and antenna configuration		AWGN (1 x 2)		
SNR	dB	12	6	0
$\hat{I}_{or}^{(j)}$	dB[mW/15kHz]	-86	-92	-98
$N_{oc}^{(j)}$	dB[mW/15kHz]	-98	-98	-98
Physical channel for CQI reporting		PUCCH Format 2		
PUCCH Report Type		4		
Reporting periodicity	ms	$N_{pd} = 40$		
<i>cqi-pmi-ConfigurationIndex</i>		38	43 (shift of 5 ms relative to Pcell)	48 for SCell 2 (shift of 10 ms relative to Pcell), 53 for SCell 3 (shift of 15 ms relative to Pcell), 58 for SCell 4 (shift of 20 ms relative to Pcell), 63 for SCell 5 (shift of 25 ms relative to Pcell), 68 for SCell 5 (shift of 30 ms relative to Pcell)
Note 1:	3 symbols are allocated to PDCCH. No PDSCH for user data is scheduled for the UE with one sided dynamic OCNG Pattern OP.1 FDD and OP.1 TDD as described in Annex A.5.1.1 and A.5.2.1.			
Note 2:	Void			
Note 3:	Void			

**Table 9.6.1.4-11: PUCCH 1-0 static test (TDD-FDD CA with TDD PCell, 7 DL CA)**

Test number	Bandwidth combination (MHz)
1	1x20(FDD)+ 6x20(TDD)MHz
2	2x20(FDD)+5x20(TDD)MHz
Note 1:	The applicability of requirements for different CA configurations and bandwidth combination sets is defined in 9.1.1.2A. The test coverage for different number of component carriers is defined in 9.1.1.3.
Note 2:	If more than one cell can be configured as PCell, choose one of the cells with the smallest bandwidth as PCell. Mapping of PCell and Scells to the CCs shall be constant for all the iterations during the test. Each execution of the test shall use the same mapping.

## 9.7 CSI reporting (Single receiver antenna)

The number of receiver antennas  $N_{RX}$  assumed for the minimum performance requirement in this clause is 1.

## 9.7.1 CQI reporting definition under AWGN conditions

### 9.7.1.1 FDD and half-duplex FDD

The following requirements apply to UE DL Category 0. For the parameters specified in Table 9.7.1.1-1, and using the downlink physical channels specified in tables C.3.2-1 and C.3.2-2, the reported CQI value according to RC.16 FDD in Table A.4-1 shall be in the range of  $\pm 1$  of the reported median more than 90% of the time. If the PDSCH BLER using the transport format indicated by median CQI is less than or equal to 0.1, the BLER using the transport format indicated by the (median CQI + 1) shall be greater than 0.1. If the PDSCH BLER using the transport format indicated by the median CQI is greater than 0.1, the BLER using transport format indicated by (median CQI – 1) shall be less than or equal to 0.1.

**Table 9.7.1.1-1: PUCCH 1-0 static test (FDD and half-duplex FDD)**

Parameter		Unit	Test 1		Test 2	
Bandwidth		MHz	10			
PDSCH transmission mode			1			
Downlink power allocation	$\rho_A$	dB	0			
	$\rho_B$	dB	0			
	$\sigma$	dB	0			
Propagation condition and antenna configuration			AWGN (1 x 1)			
SNR (Note 2)		dB	0	1	6	7
$\hat{I}_{or}^{(j)}$		dB[mW/15kHz]	-98	-97	-92	-91
$N_{oc}^{(j)}$		dB[mW/15kHz]	-98		-98	
Max number of HARQ transmissions			1			
Physical channel for CQI reporting			PUCCH Format 2			
PUCCH Report Type			4			
Reporting periodicity		ms	$N_{pd} = 40$			
<i>cqi-pmi-ConfigurationIndex</i>			41			
Note 1: Reference measurement channel RC.16 FDD according to Table A.4-1 with one/two sided dynamic OCNG Pattern OP.1/OP.2 FDD as described in Annex A.5.1.1/A.5.1.2.						
Note 2: For each test, the minimum requirements shall be fulfilled for at least one of the two SNR(s) and the respective wanted signal input level.						

### 9.7.1.2 TDD

The following requirements apply to UE DL Category 0. For the parameters specified in Table 9.7.1.2-1, and using the downlink physical channels specified in tables C.3.2-1 and C.3.2-2, the reported CQI value according to RC.16 TDD in Table A.4-1 shall be in the range of  $\pm 1$  of the reported median more than 90% of the time. If the PDSCH BLER using the transport format indicated by median CQI is less than or equal to 0.1, the BLER using the transport format indicated by the (median CQI + 1) shall be greater than 0.1. If the PDSCH BLER using the transport format indicated by the median CQI is greater than 0.1, the BLER using transport format indicated by (median CQI – 1) shall be less than or equal to 0.1.

Table 9.7.1.2-1: PUCCH 1-0 static test (TDD)

Parameter		Unit	Test 1		Test 2	
Bandwidth		MHz	10			
PDSCH transmission mode			1			
Uplink downlink configuration			2			
Special subframe configuration			4			
Downlink power allocation	$\rho_A$	dB	0			
	$\rho_B$	dB	0			
	$\sigma$	dB	0			
Propagation condition and antenna configuration			AWGN (1 x 1)			
SNR (Note 2)		dB	0	1	6	7
$\hat{I}_{or}^{(j)}$		dB[mW/15kHz]	-98	-97	-92	-91
$N_{oc}^{(j)}$		dB[mW/15kHz]	-98		-98	
Max number of HARQ transmissions			1			
Physical channel for CQI reporting			PUSCH (Note 3)			
PUCCH Report Type			4			
Reporting periodicity		ms	$N_{pd} = 5$			
cqi-pmi-ConfigurationIndex			3			
ACK/NACK feedback mode			Multiplexing			
<p>Note 1: Reference measurement channel RC.16 TDD according to Table A.4-1 with one/two sided dynamic OCN Pattern OP.1/OP.2 TDD as described in Annex A.5.2.1/A.5.2.2.</p> <p>Note 2: For each test, the minimum requirements shall be fulfilled for at least one of the two SNR(s) and the respective wanted signal input level.</p> <p>Note 3: To avoid collisions between CQI reports and HARQ-ACK it is necessary to report both on PUSCH instead of PUCCH. PDCCH DCI format 0 shall be transmitted in downlink SF#3 and #8 to allow periodic CQI to multiplex with the HARQ-ACK on PUSCH in uplink subframe SF#7 and #2.</p>						

### 9.7.1.3 FDD (Category 1bis UE)

The following requirements apply to UE DL Category 1bis. For the parameters specified in Table 9.7.1.3-1, and using the downlink physical channels specified in tables C.3.2-1 and C.3.2-2, the reported CQI value according to RC.4 FDD in Table A.4-1 shall be in the range of  $\pm 1$  of the reported median more than 90% of the time. If the PDSCH BLER using the transport format indicated by median CQI is less than or equal to 0.1, the BLER using the transport format indicated by the (median CQI + 1) shall be greater than 0.1. If the PDSCH BLER using the transport format indicated by the median CQI is greater than 0.1, the BLER using transport format indicated by (median CQI - 1) shall be less than or equal to 0.1.

Table 9.7.1.3-1: PUCCH 1-0 static test (FDD)

Parameter		Unit	Test 1		Test 2	
Bandwidth		MHz	10			
PDSCH transmission mode			1			
Downlink power allocation	$\rho_A$	dB	0			
	$\rho_B$	dB	0			
	$\sigma$	dB	0			

Propagation condition and antenna configuration		AWGN (1 x 1)			
SNR (Note 2)	dB	0	1	6	7
$\hat{I}_{or}^{(j)}$	dB[mW/15kHz]	-98	-97	-92	-91
$N_{oc}^{(j)}$	dB[mW/15kHz]	-98		-98	
Max number of HARQ transmissions		1			
Physical channel for CQI reporting		PUCCH Format 2			
PUCCH Report Type		4			
Reporting periodicity	ms	$N_{pd} = 5$			
<i>cqi-pmi-ConfigurationIndex</i>		6			
Note 1: Reference measurement channel RC.4 FDD according to Table A.4-1 with one/two sided dynamic OCN Pattern OP.2 FDD as described in Annex A.5.1.2.					
Note 2: For each test, the minimum requirements shall be fulfilled for at least one of the two SNR(s) and the respective wanted signal input level.					

#### 9.7.1.4 TDD (Category 1bis UE)

The following requirements apply to UE DL Category 1bis. For the parameters specified in Table 9.7.1.4-1, and using the downlink physical channels specified in tables C.3.2-1 and C.3.2-2, the reported CQI value according to RC.4 TDD in Table A.4-1 shall be in the range of  $\pm 1$  of the reported median more than 90% of the time. If the PDSCH BLER using the transport format indicated by median CQI is less than or equal to 0.1, the BLER using the transport format indicated by the (median CQI + 1) shall be greater than 0.1. If the PDSCH BLER using the transport format indicated by the median CQI is greater than 0.1, the BLER using transport format indicated by (median CQI – 1) shall be less than or equal to 0.1.

**Table 9.7.1.4-1: PUCCH 1-0 static test (TDD)**

Parameter		Unit	Test 1		Test 2	
Bandwidth		MHz	10			
PDSCH transmission mode			1			
Uplink downlink configuration			2			
Special subframe configuration			4			
Downlink power allocation	$\rho_A$	dB	0			
	$\rho_B$	dB	0			
	$\sigma$	dB	0			
Propagation condition and antenna configuration			AWGN (1 x 1)			
SNR (Note 2)	dB	0	1	6	7	
$\hat{I}_{or}^{(j)}$	dB[mW/15kHz]	-98	-97	-92	-91	
$N_{oc}^{(j)}$	dB[mW/15kHz]	-98		-98		
Max number of HARQ transmissions		1				
Physical channel for CQI reporting		PUSCH (Note 3)				
PUCCH Report Type		4				
Reporting periodicity	ms	$N_{pd} = 5$				
<i>cqi-pmi-ConfigurationIndex</i>		3				
ACK/NACK feedback mode		Multiplexing				
Note 1: Reference measurement channel RC.4 TDD according to Table A.4-1 with one/two sided dynamic OCN Pattern OP.1/OP.2 TDD as described in Annex A.5.2.1/A.5.2.2.						
Note 2: For each test, the minimum requirements shall be fulfilled for at least one of the two SNR(s) and the respective wanted signal input level.						
Note 3: To avoid collisions between CQI reports and HARQ-ACK it is necessary to report both on PUSCH instead of PUCCH. PDCCH DCI format 0 shall be transmitted in downlink SF#3 and #8 to allow periodic CQI to multiplex with the HARQ-ACK on PUSCH in uplink subframe SF#7 and #2.						

## 9.7.2 CQI reporting under fading conditions

### 9.7.2.1 FDD and half-duplex FDD

For the parameters specified in Table 9.7.2.1-1, and using the downlink physical channels specified in Annex C.3.2, the minimum requirements are specified in Table 9.7.2.1-2 and by the following

- a sub-band differential CQI offset level of 0 shall be reported at least  $\alpha\%$  of the time but less than  $\beta\%$  for each sub-band;
- the ratio of the throughput obtained when transmitting on a randomly selected sub-band among the sub-bands with the highest differential CQI offset level the corresponding TBS and that obtained when transmitting the TBS indicated by the reported wideband CQI median on a randomly selected sub-band in set  $S$  shall be  $\geq \gamma$ ;
- when transmitting on a randomly selected sub-band among the sub-bands with the highest differential CQI offset level the corresponding TBS, the average BLER for the indicated transport formats shall be greater or equal to 0.05.

The requirements only apply for sub-bands of full size and the random scheduling across the sub-bands is done by selecting a new sub-band in each TTI for FDD and in each available downlink transmission instance for half-duplex FDD.

**Table 9.7.2.1-1 Sub-band test for single antenna transmission (FDD and half-duplex FDD)**

Parameter	Unit	Test 1		Test 2	
Bandwidth	MHz	10 MHz			
Transmission mode		1 (port 0)			
Downlink power allocation	$\rho_A$	dB			
	$\rho_B$	dB			
	$\sigma$	dB			
SNR (Note 3)	dB	8	9	13	14
$\hat{I}_{or}^{(j)}$	dB[mW/15kHz]	-90	-89	-85	-84
$N_{oc}^{(j)}$	dB[mW/15kHz]	-98		-98	
Propagation channel		Clause B.2.4 with $\tau_d = 0.45 \mu s$ , $a = 1$ , $f_D = 5$ Hz			
Antenna configuration		1 x 1			
Reporting interval	ms	8			
CQI delay	ms	8			
Reporting mode		PUSCH 3-0			
Sub-band size	RB	6 (full size)			
Max number of HARQ transmissions		1			
<p>Note 1: If the UE reports in an available uplink reporting instance at subframe SF#n based on CQI estimation at a downlink subframe not later than SF#(n-4), this reported subband or wideband CQI cannot be applied at the eNB downlink before SF#(n+4)</p> <p>Note 2: Reference measurement channel RC.16 FDD according to Table A.4-1 with one/two sided dynamic OCNG Pattern OP.1/2 FDD as described in Annex A.5.1.1/2.</p> <p>Note 3: For each test, the minimum requirements shall be fulfilled for at least one of the two SNR(s) and the respective wanted signal input level.</p>					

**Table 9.7.2.1-2 Minimum requirement (FDD and half-duplex FDD)**

	Test 1	Test 2
$\alpha$ [%]	2	2
$\beta$ [%]	55	55
$\gamma$	1.1	1.1
UE DL Category	0	0

## 9.7.2.2 TDD

For the parameters specified in Table 9.7.2.2-1, and using the downlink physical channels specified in Annex C.3.2, the minimum requirements are specified in Table 9.7.2.2-2 and by the following

- a sub-band differential CQI offset level of 0 shall be reported at least  $\alpha\%$  of the time but less than  $\beta\%$  for each sub-band;
- the ratio of the throughput obtained when transmitting on a randomly selected sub-band among the sub-bands with the highest differential CQI offset level the corresponding TBS and that obtained when transmitting the TBS indicated by the reported wideband CQI median on a randomly selected sub-band in set  $S$  shall be  $\geq \gamma$ ;
- when transmitting on a randomly selected sub-band among the sub-bands with the highest differential CQI offset level the corresponding TBS, the average BLER for the indicated transport formats shall be greater or equal to 0.05.

The requirements only apply for sub-bands of full size and the random scheduling across the sub-bands is done by selecting a new sub-band in each available downlink transmission instance for TDD.

**Table 9.7.2.2-1 Sub-band test for single antenna transmission (TDD)**

Parameter		Unit	Test 1		Test 2	
Bandwidth		MHz	10 MHz			
Transmission mode			1 (port 0)			
Downlink power allocation	$\rho_A$	dB	0			
	$\rho_B$	dB	0			
	$\sigma$	dB	0			
Uplink downlink configuration			2			
Special subframe configuration			4			
SNR (Note 3)		dB	8	9	13	14
$\hat{I}_{or}^{(j)}$		dB[mW/15kHz]	-90	-89	-85	-84
$N_{oc}^{(j)}$		dB[mW/15kHz]	-98		-98	
Propagation channel			Clause B.2.4 with $\tau_d = 0.45$ $\mu s, a = 1, f_D = 5$ Hz			
Antenna configuration			1 x 1			
Reporting interval		ms	5			
CQI delay		ms	10 or 11			
Reporting mode			PUSCH 3-0			
Sub-band size		RB	6 (full size)			
Max number of HARQ transmissions			1			
ACK/NACK feedback mode			Multiplexing			
<p>Note 1: If the UE reports in an available uplink reporting instance at subframe SF#n based on CQI estimation at a downlink subframe not later than SF#(n-4), this reported subband or wideband CQI cannot be applied at the eNB downlink before SF#(n+4)</p> <p>Note 2: Reference measurement channel RC.16 TDD according to Table A.4-1 with one/two sided dynamic OCNG Pattern OP.1/2 TDD as described in Annex A.5.2.1/2.</p> <p>Note 3: For each test, the minimum requirements shall be fulfilled for at least one of the two SNR(s) and the respective wanted signal input level.</p>						

**Table 9.7.2.2-2 Minimum requirement (TDD)**

	Test 1	Test 2
$\alpha$ [%]	2	2
$\beta$ [%]	55	55
$\gamma$	1.1	1.1
UE DL Category	0	0

### 9.7.2.3 FDD (Category 1bis UE)

The following requirements apply to UE DL Category 1bis. For the parameters specified in Table 9.7.2.3-1, and using the downlink physical channels specified in Annex C.3.2, the minimum requirements are specified in Table 9.7.2.3-2 and by the following

- a sub-band differential CQI offset level of 0 shall be reported at least  $\alpha\%$  of the time but less than  $\beta\%$  for each sub-band;
- the ratio of the throughput obtained when transmitting on a randomly selected sub-band among the sub-bands with the highest differential CQI offset level the corresponding TBS and that obtained when transmitting the TBS indicated by the reported wideband CQI median on a randomly selected sub-band in set  $S$  shall be  $\geq \gamma$ ;
- when transmitting on a randomly selected sub-band among the sub-bands with the highest differential CQI offset level the corresponding TBS, the average BLER for the indicated transport formats shall be greater or equal to 0.05.

The requirements only apply for sub-bands of full size and the random scheduling across the sub-bands is done by selecting a new sub-band in each TTI.

**Table 9.7.2.3-1 Sub-band test for single antenna transmission (FDD)**

Parameter		Unit	Test 1		Test 2	
Bandwidth		MHz	10 MHz			
Transmission mode			1 (port 0)			
Downlink power allocation	$\rho_A$	dB	0			
	$\rho_B$	dB	0			
	$\sigma$	dB	0			
SNR (Note 3)		dB	8	9	13	14
$\hat{I}_{or}^{(j)}$		dB[mW/15kHz]	-90	-89	-85	-84
$N_{oc}^{(j)}$		dB[mW/15kHz]	-98		-98	
Propagation channel			Clause B.2.4 with $\tau_d = 0.45 \mu s$ , $a = 1$ , $f_D = 5$ Hz			
Antenna configuration			1 x 1			
Reporting interval		ms	5			
CQI delay		ms	8			
Reporting mode			PUSCH 3-0			
Sub-band size		RB	6 (full size)			
Max number of HARQ transmissions			1			
<p>Note 1: If the UE reports in an available uplink reporting instance at subframe SF#n based on CQI estimation at a downlink subframe not later than SF#(n-4), this reported subband or wideband CQI cannot be applied at the eNB downlink before SF#(n+4)</p> <p>Note 2: Reference measurement channel RC.3 FDD according to Table A.4-1 with one/two sided dynamic OCNG Pattern OP.2 FDD as described in Annex A.5.1.2.</p> <p>Note 3: For each test, the minimum requirements shall be fulfilled for at least one of the two SNR(s) and the respective wanted signal input level.</p>						

**Table 9.7.2.3-2 Minimum requirement (FDD)**

	Test 1	Test 2
$\alpha$ [%]	2	2
$\beta$ [%]	55	55
$\gamma$	1.15	1.15
UE DL Category	1bis	1bis

#### 9.7.2.4 TDD (Category 1bis UE)

The following requirements apply to UE DL Category 1bis. For the parameters specified in Table 9.7.2.4-1, and using the downlink physical channels specified in Annex C.3.2, the minimum requirements are specified in Table 9.7.2.4-2 and by the following

- a sub-band differential CQI offset level of 0 shall be reported at least  $\alpha\%$  of the time but less than  $\beta\%$  for each sub-band;
- the ratio of the throughput obtained when transmitting on a randomly selected sub-band among the sub-bands with the highest differential CQI offset level the corresponding TBS and that obtained when transmitting the TBS indicated by the reported wideband CQI median on a randomly selected sub-band in set  $S$  shall be  $\geq \gamma$ ;
- when transmitting on a randomly selected sub-band among the sub-bands with the highest differential CQI offset level the corresponding TBS, the average BLER for the indicated transport formats shall be greater or equal to 0.05.

The requirements only apply for sub-bands of full size and the random scheduling across the sub-bands is done by selecting a new sub-band in each available downlink transmission instance for TDD.

**Table 9.7.2.4-1 Sub-band test for single antenna transmission (TDD)**

Parameter		Unit	Test 1	Test 2
Bandwidth		MHz	10 MHz	
Transmission mode			1 (port 0)	
Downlink power allocation	$\rho_A$	dB	0	
	$\rho_B$	dB	0	
	$\sigma$	dB	0	



Uplink downlink configuration		2			
Special subframe configuration		4			
SNR (Note 3)	dB	8	9	13	14
$\hat{I}_{or}^{(j)}$	dB[mW/15kHz]	-90	-89	-85	-84
$N_{oc}^{(j)}$	dB[mW/15kHz]	-98		-98	
Propagation channel		Clause B.2.4 with $\tau_d = 0.45$ $\mu s$ , $a = 1$ , $f_D = 5$ Hz			
Antenna configuration		1 x 1			
Reporting interval	ms	5			
CQI delay	ms	10 or 11			
Reporting mode		PUSCH 3-0			
Sub-band size	RB	6 (full size)			
Max number of HARQ transmissions		1			
ACK/NACK feedback mode		Multiplexing			
Note 1:	If the UE reports in an available uplink reporting instance at subframe SF#n based on CQI estimation at a downlink subframe not later than SF#(n-4), this reported subband or wideband CQI cannot be applied at the eNB downlink before SF#(n+4)				
Note 2:	Reference measurement channel RC.3 TDD according to Table A.4-1 with one/two sided dynamic OCNG Pattern OP.1/2 TDD as described in Annex A.5.2.1/2.				
Note 3:	For each test, the minimum requirements shall be fulfilled for at least one of the two SNR(s) and the respective wanted signal input level.				

Table 9.7.2.4-2 Minimum requirement (TDD)

	Test 1	Test 2
$\alpha$ [%]	2	2
$\beta$ [%]	55	55
$\gamma$	1.15	1.15
UE DL Category	1bis	1bis

## 9.8 CSI reporting (UE supporting coverage enhancement)

The requirements in this sub-clause are defined based on the simulation results with UE DL Category M1 unless otherwise stated.

The requirements of UE DL Category M1 in 9.8.1 and 9.8.2 are applicable for UE DL Category M2 and UE DL Category 0.

The requirements of UE DL Category M1 in 9.8.3 and 9.8.4 are applicable for UE DL Category M2.

The requirements in 9.8.5 are defined based on the simulation results with Non-BL UEs, and they are applicable for non-BL UEs supporting coverage enhancement.

### 9.8.1 CQI reporting definition under AWGN conditions

#### 9.8.1.1 FDD and half-duplex FDD

The following requirements apply to UE supporting coverage enhancement. For the parameters specified in Table 9.8.1.1-1, and using the downlink physical channels specified in tables C.3.2-1 and C.3.2-2, the reported CQI value according to RC.23 FDD in Table A.4-1 shall be in the range of  $\pm 1$  of the reported median more than 90% of the time. If the PDSCH BLER using the transport format indicated by median CQI is less than or equal to 0.1, the BLER using the transport format indicated by the (median CQI + 1) shall be greater than 0.1. If the PDSCH BLER using the

transport format indicated by the median CQI is greater than 0.1, the BLER using transport format indicated by (median CQI – 1) shall be less than or equal to 0.1.

**Table 9.8.1.1-1: PUCCH 1-0 static test (FDD and half-duplex FDD)**

Parameter	Unit	Test 1	
Bandwidth	MHz	10	
PDSCH transmission mode		1	
Downlink power allocation	$\rho_A$	0	
	$\rho_B$	0	
	$\sigma$	0	
	$\delta$	0	
Propagation condition and antenna configuration		AWGN (1 x 1)	
SNR (Note 2)	dB	5	6
$\hat{I}_{or}^{(j)}$	dB[mW/15kHz]	-93	-92
$N_{oc}^{(j)}$	dB[mW/15kHz]	-98	-98
Max number of HARQ transmissions		1	
Physical channel for CQI reporting		PUSCH (Note 4)	
PUCCH Report Type		4	
Reporting periodicity	ms	$N_{PR} = 10$	
CQI delay	ms	10	
<i>cqi-pmi-ConfigurationIndex</i>		12	
Frequency hopping		Disabled	
Frequency hopping interval (interval-FDD)		N/A	
Starting OFDM symbol (startSymbolBR)		3	
PDSCH repetition level		1	
MPDCCH repetition level		1	
Beamforming Precoder for MPDCCH		No precoding	
Precoder update granularity for MPDCCH		N/A	
BL/CE DL subframe configuration (fdd-DownlinkOrTddSubframeBitmapBR)		1111111111	
Note 1:	Reference measurement channel RC.23 FDD according to Table A.4-1 with one sided dynamic OCNB Pattern OP.1 FDD and two sided dynamic OCNB pattern OP.2 FDD as described in Annex A.5.1.1 and A.5.1.2.		
Note 2:	The minimum requirements shall be fulfilled for at least one of the two SNR(s) and the respective wanted signal input level.		
Note 3:	DC subcarrier puncturing shall be considered.		
Note 4:	To avoid collisions between CQI reports and HARQ-ACK it is necessary to report both on PUSCH instead of PUCCH. MPDCCH DCI format 6-0A shall be transmitted in downlink SF#1 to allow periodic CQI to multiplex with the HARQ-ACK on PUSCH in uplink subframe SF#5.		

### 9.8.1.2 TDD

The following requirements apply to UE supporting coverage enhancement. For the parameters specified in Table 9.7.3.2-1, and using the downlink physical channels specified in tables C.3.2-1 and C.3.2-2, the reported CQI value according to RC.23 TDD in Table A.4-1 shall be in the range of  $\pm 1$  of the reported median more than 90% of the time. If the PDSCH BLER using the transport format indicated by median CQI is less than or equal to 0.1, the BLER using the transport format indicated by the (median CQI + 1) shall be greater than 0.1. If the PDSCH BLER using the transport format indicated by the median CQI is greater than 0.1, the BLER using transport format indicated by (median CQI – 1) shall be less than or equal to 0.1.

Table 9.8.1.2-1: PUCCH 1-0 static test (TDD)

Parameter	Unit	Test 1	
Bandwidth	MHz	10	
PDSCH transmission mode		1	
Downlink power allocation	$\rho_A$	dB	0
	$\rho_B$	dB	0
	$\sigma$	dB	0
	$\delta$	dB	0
Propagation condition and antenna configuration		AWGN (1 x 1)	
SNR (Note 2)	dB	4	5
$\hat{I}_{or}^{(j)}$	dB[mW/15kHz]	-94	-93
$N_{oc}^{(j)}$	dB[mW/15kHz]	-98	-98
Max number of HARQ transmissions		1	
Physical channel for CQI reporting		PUSCH (Note 3)	
PUCCH Report Type		4	
Reporting periodicity	ms	$N_{pd} = 5$	
<i>cqi-pmi-ConfigurationIndex</i>		3	
Frequency hopping		Disabled	
Frequency hopping interval (interval-TDD)		N/A	
Starting OFDM symbol (startSymbolLC)		3	
PDSCH repetition level		1	
ACK/NACK feedback mode		Multiplexing	
MPDCCH repetition level		1	
Beamforming Precoder for MPDCCH		No precoding	
Precoder update granularity for MPDCCH		N/A	
BL/CE DL subframe configuration (fdd-DownlinkOrTddSubframeBitmapBR)		1011110111	
Note 1:	Reference measurement channel RC.23 TDD according to Table A.4-1 with one sided dynamic OCNG Pattern OP.1 TDD and two sided dynamic OCNG pattern OP.2 TDD as described in Annex A.5.2.1 and A.5.2.2.		
Note 2:	The minimum requirements shall be fulfilled for at least one of the two SNR(s) and the respective wanted signal input level.		
Note 3:	To avoid collisions between CQI reports and HARQ-ACK it is necessary to report both on PUSCH instead of PUCCH. MPDCCH DCI format 6-0A shall be transmitted in downlink SF#3 and #8 to allow periodic CQI to multiplex with the HARQ-ACK on PUSCH in uplink subframe SF#7 and #2.		
Note 4:	DC subcarrier puncturing shall be considered.		

## 9.8.2 UE-selected subband CQI

### 9.8.2.1 FDD and half-duplex FDD

The following requirements apply to UE supporting coverage enhancement. For the parameters specified in Table 9.8.2.1-1, and using the downlink physical channels specified in Annex C.3.2, the minimum requirements are specified in Table 9.8.2.1-2 and by the following

- a) the ratio of the throughput obtained when transmitting on the best narrowband reported by the UE the corresponding TBS and that obtained when transmitting the TBS indicated by the reported wideband CQI median on a randomly selected narrowband within the set of narrowbands in which MPDCCH is monitored shall be  $\geq \gamma$ ;

The requirements only apply for narrowbands of full size and the random scheduling across the narrowbands is done by selecting a new narrowband in each TTI for FDD and half-duplex FDD. The transport block size TBS (wideband CQI median) is that resulting from the code rate which is closest to that indicated by the wideband CQI median and the  $N_{PRB}$  entry in Table 7.1.7.2.1-1 of TS 36.213 [6] that corresponds to the narrowband size.

**Table 9.8.2.1-1 Sub-band test for single antenna transmission (FDD and half-duplex FDD)**

Parameter	Unit	Test 1	
Bandwidth	MHz	10 MHz	
Transmission mode		1 (port 0)	
Downlink power allocation	$\rho_A$	dB	0
	$\rho_B$	dB	0
	$\sigma$	dB	0
	$\delta$	dB	0
SNR (Note 3)	dB	5	6
$\hat{I}_{or}^{(j)}$	dB[mW/15kHz]	-93	-92
$N_{oc}^{(j)}$	dB[mW/15kHz]	-98	-98
Propagation channel		Clause B.2.4 with $\tau_d = 0.45 \mu\text{s}$ , $a = 1$ , $f_D = 1 \text{ Hz}$	
Reporting interval	ms	10	
CQI delays for each narrowband	ms	11, 12, 13, 14	
Reporting mode		PUSCH 2-0	
Max number of HARQ transmissions		1	
Number of preferred subbands ( $M$ )		1	
Number of narrowbands		4	
Frequency hopping		Enabled	
Frequency hopping offset		1	
Starting OFDM symbol (startSymbolBR)		3	
Maximum number of MPDCCH repetitions (mpdcch-NumRepetition)		4	
MPDCCH repetition level (Note 6)		1	
PDSCH repetition level		1	
MPDCCH narrowband (mpdcch-Narrowband)		7 (Note 5)	
MPDCCH hopping interval (interval-FDD)		1	
Start subframe configuration for MPDCCH (mpdcch-startSF-UeSS)		2.5	
Beamforming Precoder for MPDCCH		No preconding	
Precoder update granularity for MPDCCH		N/A	
BL/CE DL subframe configuration (fdd-DownlinkOrTddSubframeBitmapBR)		1111111111	
$R_{csi}^{(j)}$ (csi-NumRepetitionCE)	Subframe	1	

Note 1:	If the UE reports in an available uplink reporting instance at subframe SF#n based on CQI estimation at a downlink subframe not later than SF#(n-4), this reported narrowband or wideband CQI cannot be applied at the eNB downlink before SF#(n+4)
Note 2:	Reference measurement channel RC.25 FDD according to Table A.4-1 with one sided and dynamic OCNG Pattern OP.1/2 FDD as described in Annex A.5.1.1/2.
Note 3:	The minimum requirements shall be fulfilled for at least one of the two SNR(s) and the respective wanted signal input level
Note 4:	DC subcarrier puncturing shall be considered
Note 5:	For RRC parameter setting, mpdcch-narroband is set to 8.
Note 6:	DCI format 6-1A is scheduled in the subframe k2 according to TS36.213 subclause 9.1.5.

**Table 9.8.2.1-2 Minimum requirement (FDD and half-duplex FDD)**

	Test 1
$\gamma$	1.3
UE DL Category	M1, $\geq 0$

### 9.8.2.2 TDD

The following requirements apply to UE supporting coverage enhancement. For the parameters specified in Table 9.8.2.2-1, and using the downlink physical channels specified in Annex C.3.2, the minimum requirements are specified in Table 9.8.2.2-2 and by the following

- a) the ratio of the throughput obtained when transmitting on the best narrowband reported by the UE the corresponding TBS and that obtained when transmitting the TBS indicated by the reported wideband CQI median on a randomly selected narrowband within the set of narrowbands in which MPDCCH is monitored shall be  $\geq \gamma$ ;

The requirements only apply for subbands of full size and the random scheduling across the subbands is done by selecting a new narrowband in each available downlink transmission instance for TDD. The transport block size TBS (wideband CQI median) is that resulting from the code rate which is closest to that indicated by the wideband CQI median and the  $N_{PRB}$  entry in Table 7.1.7.2.1-1 of TS 36.213 [6] that corresponds to the narrowband size.

**Table 9.8.2.2-1 Sub-band test for single antenna transmission (TDD)**



Parameter	Unit	Test 1	
Bandwidth	MHz	10 MHz	
Transmission mode		1 (port 0)	
Downlink power allocation	$\rho_A$	dB	0
	$\rho_B$	dB	0
	$\sigma$	dB	0
	$\delta$	dB	0
Uplink downlink configuration		2	
Special subframe configuration		4	
SNR (Note 3)	dB	5	6
$\hat{I}_{or}^{(j)}$	dB[mW/15kHz]	-93	-92
$N_{oc}^{(j)}$	dB[mW/15kHz]	-98	-98
Propagation channel		Clause B.2.4 with $\tau_d = 0,45 \mu\text{s}$ , $a = 1$ , $f_D = 1 \text{ Hz}$	
Reporting interval	ms	20	
CQI delay	ms	23, 24, 25, 28	
Reporting mode		PUSCH 2-0	
Max number of HARQ transmissions		1	
Number of preferred subbands ( $M$ )		1	
ACK/NACK feedback mode		Multiplexing	
Number of narrowbands		4	
Frequency hopping		Enabled	
Frequency hopping offset		1	
Starting OFDM symbol (startSymbolBR)		3	
Maximum number of MPDCCH repetitions (mpdcch-NumRepetition)		4	
PDSCH repetition level		1	
MPDCCH narrowband (mpdcch-Narrowband)		7 (Note 5)	
MPDCCH hopping interval (interval-TDD)		1	
Start subframe configuration for MPDCCH (mpdcch-startSF-UeSS)		5	
Beamforming Precoder for MPDCCH		No precoding	
Precoder update granularity for MPDCCH		N/A	
BL/CE DL subframe configuration (fdd-DownlinkOrTddSubframeBitmapBR)		1011110111	
$R_{csi}^{(j)}$ (csi-NumRepetitionCE)	Subframe	1	

Note 1:	If the UE reports in an available uplink reporting instance at subframe SF#n based on CQI estimation at a downlink subframe not later than SF#(n-4), this reported subband or wideband CQI cannot be applied at the eNB downlink before SF#(n+4)
Note 2:	Reference measurement channel RC.25 TDD according to Table A.4-1 with one sided and dynamic OCNG Pattern OP.1/2 TDD as described in Annex A.5.2.1/2.
Note 3:	The minimum requirements shall be fulfilled for at least one of the two SNR(s) and the respective wanted signal input level.
Note 4:	DC subcarrier puncturing shall be considered
Note 5:	For RRC parameter setting, mpdcch-narroband is set to 8.
Note 6:	DCI format 6-1A is scheduled in the subframe k2 according to TS36.213 subclause 9.1.5.
Note 7:	In the case CQI reports and HARQ-ACK collide, CQI reports and HARQ-ACK will be multiplexed.

**Table 9.8.2.2-2 Minimum requirement (TDD)**

	<b>Test 1</b>
$\gamma$	1.3
UE Category	M1, $\geq 0$

### 9.8.3 CQI reporting definition for UE supporting 64QAM under AWGN

#### 9.8.3.1 FDD and half-duplex FDD

The following requirements apply to UE supporting *ce-ModeA-r13* and *ce-PDSCH-64QAM-r15*. For the parameters specified in Table 9.8.3.1-1, and using the downlink physical channels specified in tables C.3.2-1 and C.3.2-2, the reported CQI value according to RC.31 FDD in Table A.4-1 shall be in the range of  $\pm 1$  of the reported median more than 90% of the time. If the PDSCH BLER using the transport format indicated by median CQI is less than or equal to 0.1, the BLER using the transport format indicated by the (median CQI + 1) shall be greater than 0.1. If the PDSCH BLER using the transport format indicated by the median CQI is greater than 0.1, the BLER using transport format indicated by (median CQI – 1) shall be less than or equal to 0.1.

Table 9.8.3.1-1: PUCCH 1-0 static test (FDD and half-duplex FDD)

Parameter	Unit	Test 1	
Bandwidth	MHz	10	
PDSCH transmission mode		1	
Downlink power allocation	$\rho_A$	dB	0
	$\rho_B$	dB	0
	$\sigma$	dB	0
	$\delta$	dB	0
Propagation condition and antenna configuration		AWGN (1 x 1)	
SNR (Note 2)	dB	11	12
$\hat{I}_{or}^{(j)}$	dB[mW/15kHz]	-87	-86
$N_{oc}^{(j)}$	dB[mW/15kHz]	-98	-98
Max number of HARQ transmissions		1	
Physical channel for CQI reporting		PUSCH (Note 4)	
PUCCH Report Type		4	
Reporting periodicity	ms	$N_{pd} = 10$	
CQI delay	ms	10	
<i>cqi-pmi-ConfigurationIndex</i>		12	
Frequency hopping		Disabled	
Frequency hopping interval (interval-FDD)		N/A	
Starting OFDM symbol (startSymbolBR)		3	
PDSCH repetition level		1	
MPDCCH repetition level		1	
Beamforming Precoder for MPDCCH		No precoding	
Precoder update granularity for MPDCCH		N/A	
BL/CE DL subframe configuration (fdd-DownlinkOrTddSubframeBitmapBR)		1111111111	
Note 1:	Reference measurement channel RC.31 FDD according to Table A.4-1 with one sided dynamic OCNG Pattern OP.1 FDD and two sided dynamic OCNG pattern OP.2 FDD as described in Annex A.5.1.1 and A.5.1.2.		
Note 2:	The minimum requirements shall be fulfilled for at least one of the two SNR(s) and the respective wanted signal input level.		
Note 3:	DC subcarrier puncturing shall be considered.		
Note 4:	To avoid collisions between CQI reports and HARQ-ACK it is necessary to report both on PUSCH instead of PUCCH. MPDCCH DCI format 6-0A shall be transmitted in downlink SF#1 to allow periodic CQI to multiplex with the HARQ-ACK on PUSCH in uplink subframe SF#5.		

### 9.8.3.2 TDD

The following requirements apply to UE supporting supporting *ce-ModeA-r13* and *ce-PDSCH-64QAM-r15*. For the parameters specified in Table 9.8.3.2-1, and using the downlink physical channels specified in tables C.3.2-1 and C.3.2-2, the reported CQI value according to RC.31 TDD in Table A.4-1 shall be in the range of  $\pm 1$  of the reported median more than 90% of the time. If the PDSCH BLER using the transport format indicated by median CQI is less than or equal to 0.1, the BLER using the transport format indicated by the (median CQI + 1) shall be greater than 0.1. If the PDSCH BLER using the transport format indicated by the median CQI is greater than 0.1, the BLER using transport format indicated by (median CQI - 1) shall be less than or equal to 0.1.

Table 9.8.3.2-1: PUCCH 1-0 static test (TDD)

Parameter	Unit	Test 1	
Bandwidth	MHz	10	
PDSCH transmission mode		1	
Downlink power allocation	$\rho_A$	dB	0
	$\rho_B$	dB	0
	$\sigma$	dB	0
	$\delta$	dB	0
Propagation condition and antenna configuration		AWGN (1 x 1)	
SNR (Note 2)	dB	11	12
$\hat{I}_{or}^{(j)}$	dB[mW/15kHz]	-87	-86
$N_{oc}^{(j)}$	dB[mW/15kHz]	-98	-98
Max number of HARQ transmissions		1	
Physical channel for CQI reporting		PUSCH (Note 3)	
PUCCH Report Type		4	
Reporting periodicity	ms	$N_{pd} = 5$	
<i>cqi-pmi-ConfigurationIndex</i>		3	
Frequency hopping		Disabled	
Frequency hopping interval (interval-TDD)		N/A	
Starting OFDM symbol (startSymbolLC)		3	
PDSCH repetition level		1	
ACK/NACK feedback mode		Multiplexing	
MPDCCH repetition level		1	
Beamforming Precoder for MPDCCH		No precoding	
Precoder update granularity for MPDCCH		N/A	
BL/CE DL subframe configuration (fdd-DownlinkOrTddSubframeBitmapBR)		1011110111	
Note 1:	Reference measurement channel RC.31 TDD according to Table A.4-1 with one sided dynamic OCNG Pattern OP.1 TDD and two sided dynamic OCNG pattern OP.2 TDD as described in Annex A.5.2.1 and A.5.2.2.		
Note 2:	The minimum requirements shall be fulfilled for at least one of the two SNR(s) and the respective wanted signal input level.		
Note 3:	To avoid collisions between CQI reports and HARQ-ACK it is necessary to report both on PUSCH instead of PUCCH. MPDCCH DCI format 6-0A shall be transmitted in downlink SF#3 and #8 to allow periodic CQI to multiplex with the HARQ-ACK on PUSCH in uplink subframe SF#7 and #2.		
Note 4:	DC subcarrier puncturing shall be considered.		

## 9.8.4 CQI reporting definition for UE supporting alternative table under AWGN

### 9.8.4.1 FDD and half-duplex FDD

The following requirements apply to UE supporting *ce-ModeA-r13* and *ce-CQI-AlternativeTable-r15*. For the parameters specified in Table 9.8.4.1-1, and using the downlink physical channels specified in tables C.3.2-1 and C.3.2-2, the reported CQI value according to RC.32 FDD in Table A.4-1 shall be in the range of  $\pm 1$  of the reported median more than 90% of the time. If the PDSCH BLER using the transport format indicated by median CQI is less than or equal to 0.1, the BLER using the transport format indicated by the (median CQI + 1) shall be greater than 0.1. If the PDSCH BLER using the transport format indicated by the median CQI is greater than 0.1, the BLER using transport format indicated by (median CQI - 1) shall be less than or equal to 0.1.

Table 9.8.4.1-1: PUCCH 1-0 static test (FDD and half-duplex FDD)

Parameter	Unit	Test 1	
Bandwidth	MHz	10	
PDSCH transmission mode		1	
Downlink power allocation	$\rho_A$	dB	0
	$\rho_B$	dB	0
	$\sigma$	dB	0
	$\delta$	dB	0
Propagation condition and antenna configuration		AWGN (1 x 1)	
SNR (Note 2)	dB	5	6
$\hat{I}_{or}^{(j)}$	dB[mW/15kHz]	-93	-92
$N_{oc}^{(j)}$	dB[mW/15kHz]	-98	-98
Max number of HARQ transmissions		1	
Physical channel for CQI reporting		PUSCH (Note 4)	
PUCCH Report Type		4	
Reporting periodicity	ms	$N_{pd} = 10$	
CQI delay	ms	10	
<i>cqi-pmi-ConfigurationIndex</i>		12	
Frequency hopping		Disabled	
Frequency hopping interval (interval-FDD)		N/A	
Starting OFDM symbol (startSymbolBR)		3	
PDSCH repetition level		1	
MPDCCH repetition level		1	
Beamforming Precoder for MPDCCH		No precoding	
Precoder update granularity for MPDCCH		N/A	
BL/CE DL subframe configuration (fdd-DownlinkOrTddSubframeBitmapBR)		1111111111	
Note 1:	Reference measurement channel RC.32 FDD according to Table A.4-1 with one sided dynamic OCNG Pattern OP.1 FDD and two sided dynamic OCNG pattern OP.2 FDD as described in Annex A.5.1.1 and A.5.1.2.		
Note 2:	The minimum requirements shall be fulfilled for at least one of the two SNR(s) and the respective wanted signal input level.		
Note 3:	DC subcarrier puncturing shall be considered.		
Note 4:	To avoid collisions between CQI reports and HARQ-ACK it is necessary to report both on PUSCH instead of PUCCH. MPDCCH DCI format 6-0A shall be transmitted in downlink SF#1 to allow periodic CQI to multiplex with the HARQ-ACK on PUSCH in uplink subframe SF#5.		

### 9.8.4.2 TDD

The following requirements apply to UE supporting *ce-ModeA-r13* and *ce-CQI-AlternativeTable-r15*. For the parameters specified in Table 9.8.4.2-1, and using the downlink physical channels specified in tables C.3.2-1 and C.3.2-2, the reported CQI value according to RC.32 TDD in Table A.4-1 shall be in the range of  $\pm 1$  of the reported median more than 90% of the time. If the PDSCH BLER using the transport format indicated by median CQI is less than or equal to 0.1, the BLER using the transport format indicated by the (median CQI + 1) shall be greater than 0.1. If the PDSCH BLER using the transport format indicated by the median CQI is greater than 0.1, the BLER using transport format indicated by (median CQI - 1) shall be less than or equal to 0.1.

Table 9.8.4.2-1: PUCCH 1-0 static test (TDD)

Parameter	Unit	Test 1	
Bandwidth	MHz	10	
PDSCH transmission mode		1	
Downlink power allocation	$\rho_A$	0	
	$\rho_B$	0	
	$\sigma$	0	
	$\delta$	0	
Propagation condition and antenna configuration		AWGN (1 x 1)	
SNR (Note 2)	dB	5	6
$\hat{I}_{or}^{(j)}$	dB[mW/15kHz]	-93	-92
$N_{oc}^{(j)}$	dB[mW/15kHz]	-98	-98
Max number of HARQ transmissions		1	
Physical channel for CQI reporting		PUSCH (Note 3)	
PUCCH Report Type		4	
Reporting periodicity	ms	$N_{pd} = 5$	
<i>cqi-pmi-ConfigurationIndex</i>		3	
Frequency hopping		Disabled	
Frequency hopping interval (interval-TDD)		N/A	
Starting OFDM symbol (startSymbolLC)		3	
PDSCH repetition level		1	
ACK/NACK feedback mode		Multiplexing	
MPDCCH repetition level		1	
Beamforming Precoder for MPDCCH		No precoding	
Precoder update granularity for MPDCCH		N/A	
BL/CE DL subframe configuration (fdd-DownlinkOrTddSubframeBitmapBR)		1011110111	
Note 1:	Reference measurement channel RC.32 TDD according to Table A.4-1 with one sided dynamic OCNG Pattern OP.1 TDD and two sided dynamic OCNG pattern OP.2 TDD as described in Annex A.5.2.1 and A.5.2.2.		
Note 2:	The minimum requirements shall be fulfilled for at least one of the two SNR(s) and the respective wanted signal input level.		
Note 3:	To avoid collisions between CQI reports and HARQ-ACK it is necessary to report both on PUSCH instead of PUCCH. MPDCCH DCI format 6-0A shall be transmitted in downlink SF#3 and #8 to allow periodic CQI to multiplex with the HARQ-ACK on PUSCH in uplink subframe SF#7 and #2.		
Note 4:	DC subcarrier puncturing shall be considered.		

### 9.8.5 PMI reporting with PUCCH 1-1 (CSI Reference Symbol)

The minimum performance requirements of PMI reporting are defined based on the precoding gain, expressed as the relative increase in throughput when the transmitter is configured according to the UE reports compared to the case when the transmitter is using random precoding, respectively. When the transmitter uses random precoding, for each PDSCH allocation a precoder is randomly generated and applied to the PDSCH. A fixed transport format (FRC) is configured for all requirements.

The requirements are specified in terms of the ratio

$$\gamma = \frac{t_{ue}}{t_{rnd}}$$

In the definition of  $\gamma$ ,  $t_{ue}$  is 70% of the maximum throughput obtained at  $SNR_{follow}$  using the precoders configured according to the UE reports, and  $t_{rnd}$  is the throughput measured at  $SNR_{follow}$  with random precoding.

## 9.8.5.1 FDD

For the parameters specified in Table 9.8.5.1-1 and using the downlink physical channels specified in Annex C.3.2, the minimum requirements are specified in Table 9.8.5.1-2.

Table 9.8.5.1-1 PMI test for single-layer (FDD)

Parameter	Unit	Test 1	
Bandwidth	MHz	10	
Transmission mode		9	
Propagation channel		EPA5	
Precoding granularity	PRB	6	
Downlink power allocation	$\rho_A$	dB	0
	$\rho_B$	dB	0
	$\sigma$	dB	-3
	$\delta$	dB	0
$N_{oc}^{(j)}$	dB[mW/15kHz]	-98	
Correlation and antenna configuration		High XP 8 x 2	
Beamforming model		Annex B.4.3	
Cell-specific reference signals		Antenna ports 0,1	
CSI reference signals		Antenna ports 15,...,22	
CSI-RS periodicity and subframe offset $T_{CSI-RS} / \Delta_{CSI-RS}$		5/1	
CSI-RS reference signal configuration		0	
CodeBookSubsetRestriction bitmap		0x0000 0000 001F FFE0 0000 0000 FFFF	
Reporting mode		PUCCH 1-1 submode1	
Reporting interval	ms	5	
PMI delay (Note 2)	ms	10	
Physical channel for CQI/PMI reporting		PUSCH (Note 3)	
PUCCH Report Type for CQI/second PMI		2b	
PUCCH Report Type for RI/ first PMI		2a	
<i>cqi-pmi-ConfigurationIndex</i>		4	
Measurement channel		R.108 FDD	
OCNG Pattern		OP.1 FDD	
Max number of HARQ transmissions		4	
Redundancy version coding sequence		{0,1,2,3}	
ce-csi-rs-feedback-config		Configured	
Frequency hopping		Disabled	
Frequency hopping interval (interval-FDD)		N/A	
Starting OFDM symbol (startSymbolBR)		3	
PDSCH repetition level		1	
MPDCCH repetition level		1	
Beamforming Precoder for MPDCCH		No precoding	
Precoder update granularity for MPDCCH		N/A	
BL/CE DL subframe configuration (fdd-DownlinkOrTddSubframeBitmapBR)		1111111111	
Note 1: For random precoder selection, the precoder shall be updated in each TTI (1 ms granularity)			
Note 2: If the UE reports in an available uplink reporting instance at subframe SF#n based on PMI estimation at a downlink SF not later than SF#(n-4), this reported PMI cannot be applied at the eNB downlink before SF#(n+4).			
Note 3: To avoid collisions between CQI/PMI reports and HARQ-ACK it is necessary to report both on PUSCH instead of PUCCH.			
Note 4: PDSCH_RA = 0dB, PDSCH_RB = 0dB in order to have the same PDSCH and OCNG power per subcarrier at the receiver.			
Note 5: Randomization of the principle beam direction shall be used as specified in B.2.3A.4			

**Table 9.8.5.1-2 Minimum requirement (FDD)**

Parameter	Test 1
$\gamma$	1.2
UE Category	$\geq 1$

### 9.8.5.2 TDD

For the parameters specified in Table 9.8.5.2-1 and using the downlink physical channels specified in Annex C.3.2, the minimum requirements are specified in Table 9.8.5.2-2.

**Table 9.8.5.2-1 PMI test for single-layer (TDD)**

Parameter	Unit	Test 1	
Bandwidth	MHz	10	
Transmission mode		9	
Uplink downlink configuration		1	
Special subframe configuration		4	
Propagation channel		EPA5	
Precoding granularity	PRB	6	
Downlink power allocation	$\rho_A$	dB	0
	$\rho_B$	dB	0
	$P_C$	dB	-3
	$\sigma$	dB	0



$N_{\text{CR}}^{(D)}$	dB[mW/15kHz]	-98
Correlation and antenna configuration		High XP 8 x 2
Beamforming model		Annex B.4.3
Cell-specific reference signals		Antenna ports 0,1
CSI reference signals		Antenna ports 15,...,22
CSI-RS periodicity and subframe offset $T_{\text{CSI-RS}} / \Delta_{\text{CSI-RS}}$		5/4
CSI-RS reference signal configuration		6
CodeBookSubsetRestriction bitmap		0x0000 0000 001F FFE0 0000 FFFF
Reporting mode		PUCCH 1-1 submode1
Reporting interval	ms	5
PMI delay (Note 2)	ms	15
Physical channel for CQI/PMI reporting		PUSCH (Note 3)
PUCCH Report Type for CQI/second PMI		2b
PUCCH Report Type for RI/ first PMI		2a
<i>cqi-pmi-ConfigurationIndex</i>		4
Measurement channel		R.108 TDD
OCNG Pattern		OP.1 TDD
Max number of HARQ transmissions		4
Redundancy version coding sequence		{0,1,2,3}
ACK/NACK feedback mode		Multiplexing
ce-csi-rs-feedback-config		Configured
Frequency hopping		Disabled
Frequency hopping interval (interval-TDD)		N/A
Starting OFDM symbol (startSymbolBR)		3
PDSCH repetition level		1
MPDCCH repetition level		1
Beamforming Precoder for MPDCCH		No precoding
Precoder update granularity for MPDCCH		N/A
BL/CE DL subframe configuration (fd-DownlinkOrTddSubframeBitmapBR)		1011110111
Note 1: For random precoder selection, the precoder shall be updated in each TTI (1 ms granularity)		
Note 2: If the UE reports in an available uplink reporting instance at subframe SF#n based on PMI estimation at a downlink SF not later than SF#(n-4), this reported PMI cannot be applied at the eNB downlink before SF#(n+4).		
Note 3: To avoid collisions between CQI/PMI reports and HARQ-ACK it is necessary to report both on PUSCH instead of PUCCH.		
Note 4: PDCCH DCI format 0 with a trigger for aperiodic CQI shall be transmitted in downlink SF#4 and #9 to allow aperiodic CQI/PMI/RI to be transmitted on uplink SF#3 and #8.		
Note 5: Randomization of the principle beam direction shall be used as specified in B.2.3A.4.		

Table 9.8.5.2-2 Minimum requirement (TDD)

Parameter	Test 1
$\gamma$	1.2
UE Category	$\geq 1$

## 9.9 CSI reporting for 4Rx UE

### 9.9.1 CQI reporting definition under AWGN conditions

The reporting accuracy of the channel quality indicator (CQI) under frequency non-selective conditions is determined by the reporting variance and the BLER performance using the transport format indicated by the reported CQI median.

The purpose is to verify that the reported CQI values are in accordance with the CQI definition given in TS 36.213 [6]. To account for sensitivity of the input SNR the reporting definition is considered to be verified if the reporting accuracy is met for at least one of two SNR levels separated by an offset of 1 dB.

### 9.9.1.1 Minimum requirement PUCCH 1-0 with Rank 1 (Cell-Specific Reference Symbols)

#### 9.9.1.1.1 FDD

The following requirements apply to UE Category  $\geq 1$ . For the parameters specified in Table 9.9.1.1.1-1, using the downlink physical channels specified in tables C.3.2-1 and C.3.2-2, the reported CQI value according to RC.1 FDD / RC.4 FDD in Table A.4-1 shall be in the range of  $\pm 1$  of the reported median more than 90% of the time. If the PDSCH BLER using the transport format indicated by median CQI is less than or equal to 0.1, the BLER using the transport format indicated by the (median CQI + 1) shall be greater than 0.1. If the PDSCH BLER using the transport format indicated by the median CQI is greater than 0.1, the BLER using transport format indicated by (median CQI – 1) shall be less than or equal to 0.1.

**Table 9.9.1.1.1-1: PUCCH 1-0 static test (FDD)**

Parameter	Unit	Test 1		Test 2	
Bandwidth	MHz	10			
PDSCH transmission mode		1			
Downlink power allocation	$\rho_A$	dB			
	$\rho_B$	dB			
	$\sigma$	dB			
Propagation condition and antenna configuration		AWGN (1 x 4)			
SNR (Note 2)	dB	-2	-1	4	5
$\hat{I}_{or}^{(j)}$	dB[mW/15kHz]	-100	-99	-94	-93
$N_{oc}^{(j)}$	dB[mW/15kHz]	-98		-98	
Max number of HARQ transmissions		1			
Physical channel for CQI reporting		PUCCH Format 2			
PUCCH Report Type		4			
Reporting periodicity	ms	$N_{pd} = 5$			
<i>cqi-pmi-ConfigurationIndex</i>		6			
Note 1:	Reference measurement channel RC.1 FDD according to Table A.4-1 with one sided dynamic OCNG Pattern OP.1 FDD as described in Annex A.5.1.1, except for category 1 UE use RC.4 FDD with two sided dynamic OCNG Pattern OP.2 FDD as described in Annex A.5.1.2.				
Note 2:	For each test, the minimum requirements shall be fulfilled for at least one of the two SNR(s) and the respective wanted signal input level.				

#### 9.9.1.1.2 TDD

The following requirements apply to UE Category  $\geq 1$ . For the parameters specified in Table 9.9.1.1.2-1, using the downlink physical channels specified in tables C.3.2-1 and C.3.2-2, the reported CQI value according to RC.1/RC.4 TDD in Table A.4-1 shall be in the range of  $\pm 1$  of the reported median more than 90% of the time. If the PDSCH BLER using the transport format indicated by median CQI is less than or equal to 0.1, the BLER using the transport format indicated by the (median CQI + 1) shall be greater than 0.1. If the PDSCH BLER using the transport format indicated by the median CQI is greater than 0.1, the BLER using transport format indicated by (median CQI – 1) shall be less than or equal to 0.1.

Table 9.9.1.1.2-1: PUCCH 1-0 static test (TDD)

Parameter		Unit	Test 1		Test 2	
Bandwidth		MHz			10	
PDSCH transmission mode					1	
Uplink downlink configuration					2	
Special subframe configuration					4	
Downlink power allocation	$\rho_A$	dB			0	
	$\rho_B$	dB			0	
	$\sigma$	dB			0	
Propagation condition and antenna configuration			AWGN (1 x 4)			
SNR (Note 2)		dB	-2	-1	4	5
$\hat{I}_{or}^{(j)}$		dB[mW/15kHz]	-100	-99	-94	-93
$N_{oc}^{(j)}$		dB[mW/15kHz]	-98		-98	
Max number of HARQ transmissions			1			
Physical channel for CQI reporting			PUSCH (Note 3)			
PUCCH Report Type			4			
Reporting periodicity		ms	$N_{pd} = 5$			
<i>cqi-pmi-ConfigurationIndex</i>			3			
ACK/NACK feedback mode			Multiplexing			
<p>Note 1: Reference measurement channel RC.1 TDD according to Table A.4-1 with one sided dynamic OCNG Pattern OP.1 TDD as described in Annex A.5.2.1, except for category 1 UE use RC.4 TDD with two sided dynamic OCNG Pattern OP.2 TDD as described in Annex A.5.2.2.</p> <p>Note 2: For each test, the minimum requirements shall be fulfilled for at least one of the two SNR(s) and the respective wanted signal input level.</p> <p>Note 3: To avoid collisions between CQI reports and HARQ-ACK it is necessary to report both on PUSCH instead of PUCCH. PDCCH DCI format 0 shall be transmitted in downlink SF#3 and #8 to allow periodic CQI to multiplex with the HARQ-ACK on PUSCH in uplink subframe SF#7 and #2.</p>						

### 9.9.1.2 Minimum requirement PUCCH 1-1 with Rank 2 (CSI Reference Symbols)

The minimum requirements for dual codeword transmission are defined in terms of a reporting spread of the wideband CQI value for codeword #1, and their BLER performance using the transport format indicated by the reported CQI median of codeword #0 and codeword #1. The precoding used at the transmitter is a fixed precoding matrix specified by the bitmap parameter *codebookSubsetRestriction*. The propagation condition assumed for the minimum performance requirement is defined in subclause B.1.

#### 9.9.1.2.1 FDD

The following requirements apply to UE Category  $\geq 2$ . For the parameters specified in table 9.9.1.2.1-1, and using the downlink physical channels specified in tables C.3.2-1 and C.3.2-2, the reported offset level of the wideband spatial differential CQI for codeword #1 (Table 7.2-2 in TS 36.213 [6]) shall be used to determine the wideband CQI index for codeword #1 as

$$\text{wideband CQI}_1 = \text{wideband CQI}_0 - \text{Codeword 1 offset level}$$

The wideband CQI<sub>1</sub> shall be within the set {median CQI<sub>1</sub> - 1, median CQI<sub>1</sub>, median CQI<sub>1</sub> + 1} for more than 90% of the time, where the resulting wideband values CQI<sub>1</sub> shall be used to determine the median CQI values for codeword #1. For both codewords #0 and #1, the PDSCH BLER using the transport format indicated by the respective median CQI<sub>0</sub> - 1 and median CQI<sub>1</sub> - 1 shall be less than or equal to 0.1. Furthermore, for both codewords #0 and #1, the PDSCH BLER using the transport format indicated by the respective median CQI<sub>0</sub> + 1 and median CQI<sub>1</sub> + 1 shall be greater than or equal to 0.1.

Table 9.9.1.2.1-1: PUCCH 1-1 static test (FDD)

Parameter	Unit	Test 1		Test 2	
Bandwidth	MHz			10	
PDSCH transmission mode				9	
Downlink power allocation	$\rho_A$	dB		0	
	$\rho_B$	dB		0	
	$P_C$	dB		-3	
	$\sigma$	dB		-3	
Cell-specific reference signals		Antenna ports 0, 1			
CSI reference signals		Antenna ports 15, ..., 18			
CSI-RS periodicity and subframe offset $T_{\text{CSI-RS}} / \Delta_{\text{CSI-RS}}$		5/1			
CSI reference signal configuration		0			
Propagation condition and antenna configuration		Clause B.1 (4 x 4)			
Beamforming Model		As specified in Section B.4.3			
CodeBookSubsetRestriction bitmap		0x0000 0000 0100 0000			
SNR (Note 2)	dB	5	6	11	12
$\hat{I}_{or}^{(j)}$	dB[mW/15kHz]	-93	-92	-87	-86
$N_{oc}^{(j)}$	dB[mW/15kHz]	-98		-98	
Max number of HARQ transmissions		1			
Physical channel for CQI/PMI reporting		PUSCH (Note3)			
PUCCH Report Type for CQI/PMI		2			
Physical channel for RI reporting		PUCCH Format 2			
PUCCH Report Type for RI		3			
Reporting periodicity	ms	$N_{\text{pd}} = 5$			
CQI delay	ms	8			
<i>cqi-pmi-ConfigurationIndex</i>		2			
<i>ri-ConfigIndex</i>		1			
Note 1:	Reference measurement channel RC.7 FDD according to Table A.4-1 with one sided dynamic OCNG Pattern OP.1 FDD as described in Annex A.5.1.1.				
Note 2:	For each test, the minimum requirements shall be fulfilled for at least one of the two SNR(s) and the respective wanted signal input level.				
Note 3:	To avoid collisions between CQI/PMI reports and HARQ-ACK it is necessary to report both on PUSCH instead of PUCCH. PDCCCH DCI format 0 shall be transmitted in downlink SF#1 and #6 to allow periodic CQI/PMI to multiplex with the HARQ-ACK on PUSCH in uplink SF#0 and #5.				

## 9.9.1.2.2 TDD

The following requirements apply to UE Category  $\geq 2$ . For the parameters specified in table 9.9.1.2.2-1, and using the downlink physical channels specified in tables C.3.2-1 and C.3.2-2, the reported offset level of the wideband spatial differential CQI for codeword #1 (Table 7.2-2 in TS 36.213 [6]) shall be used to determine the wideband CQI index for codeword #1 as

$$\text{wideband CQI}_1 = \text{wideband CQI}_0 - \text{Codeword 1 offset level}$$

The wideband CQI<sub>1</sub> shall be within the set {median CQI<sub>1</sub> - 1, median CQI<sub>1</sub>, median CQI<sub>1</sub> + 1} for more than 90% of the time, where the resulting wideband values CQI<sub>1</sub> shall be used to determine the median CQI values for codeword #1. For both codewords #0 and #1, the PDSCH BLER using the transport format indicated by the respective median CQI<sub>0</sub> - 1 and median CQI<sub>1</sub> - 1 shall be less than or equal to 0.1. Furthermore, for both codewords #0 and #1, the PDSCH BLER using the transport format indicated by the respective median CQI<sub>0</sub> + 1 and median CQI<sub>1</sub> + 1 shall be greater than or equal to 0.1.

Table 9.9.1.2.2-1: PUCCH 1-1 submode 1 static test (TDD)

Parameter	Unit	Test 1		Test 2	
Bandwidth	MHz			10	
PDSCH transmission mode				9	
Uplink downlink configuration				2	
Special subframe configuration				4	
Downlink power allocation	$\rho_A$	dB			0
	$\rho_B$	dB			0
	$\rho_C$	dB			-6
	$\sigma$	dB			-3
CRS reference signals				Antenna ports 0, 1	
CSI reference signals				Antenna ports 15, ..., 22	
CSI-RS periodicity and subframe offset $T_{\text{CSI-RS}} / \Delta_{\text{CSI-RS}}$				5/3	
CSI reference signal configuration				0	
Propagation condition and antenna configuration				Clause B.1 (8 x 4)	
Beamforming Model				As specified in Section B.4.3	
CodeBookSubsetRestriction bitmap				0x0000 0000 0020 0000 0000 0001 0000	
SNR (Note 2)	dB	2	3	8	9
$\hat{I}_{or}^{(j)}$	dB[mW/15kHz]	-96	-95	-90	-89
$N_{oc}^{(j)}$	dB[mW/15kHz]	-98		-98	
Max number of HARQ transmissions				1	
Physical channel for CQI/PMI reporting				PUSCH (Note 3)	
PUCCH Report Type for CQI/second PMI				2b	
Physical channel for RI reporting				PUSCH	
PUCCH Report Type for RI/ first PMI				5	
Reporting periodicity	ms			$M_{pd} = 5$	
CQI delay	ms			10 or 11	
<i>cqi-pmi-ConfigurationIndex</i>				3	
<i>ri-ConfigIndex</i>				805 (Note 4)	
ACK/NACK feedback mode				Multiplexing	
Note 1:	Reference measurement channel RC.7 TDD according to Table A.4-1 with one sided dynamic OCNG Pattern OP.1 TDD as described in Annex A.5.2.1.				
Note 2:	For each test, the minimum requirements shall be fulfilled for at least one of the two SNR(s) and the respective wanted signal input level.				
Note 3:	To avoid collisions between CQI/PMI reports and HARQ-ACK it is necessary to report both on PUSCH instead of PUCCH. PDCCCH DCI format 0 shall be transmitted in downlink SF#3 and #8 to allow periodic CQI/PMI to multiplex with the HARQ-ACK on PUSCH in uplink SF#7 and #2.				
Note 4:	RI reporting interval is set to the maximum allowable length of 160ms to minimise collisions between RI, CQI/PMI and HARQ-ACK reports. In the case when all three reports collide, it is expected that CQI/PMI reports will be dropped, while RI and HARQ-ACK will be multiplexed. At eNB, CQI report collection shall be skipped every 160ms during performance verification.				

### 9.9.1.3 Minimum requirement PUCCH 1-1 with Rank 4 (Cell-Specific Reference Symbols)

The minimum requirements for dual codeword transmission are defined in terms of a reporting spread of the wideband CQI value for codeword #1, and their BLER performance using the transport format indicated by the reported CQI median of codeword #0 and codeword #1. The precoding used at the transmitter is a fixed precoding matrix specified by the bitmap parameter *codebookSubsetRestriction*. The propagation condition assumed for the minimum performance requirement is defined in subclause B.1.

## 9.9.1.3.1 FDD

The following requirements apply to UE Category  $\geq 5$ . For the parameters specified in table 9.9.1.3.1-1, and using the downlink physical channels specified in tables C.3.2-1 and C.3.2-2, the reported offset level of the wideband spatial differential CQI for codeword #1 (Table 7.2-2 in TS 36.213 [6]) shall be used to determine the wideband CQI index for codeword #1 as

$$\text{wideband CQI}_1 = \text{wideband CQI}_0 - \text{Codeword 1 offset level}$$

The wideband CQI<sub>1</sub> shall be within the set {median CQI<sub>1</sub> - 1, median CQI<sub>1</sub>, median CQI<sub>1</sub> + 1} for more than 90% of the time, where the resulting wideband values CQI<sub>1</sub> shall be used to determine the median CQI values for codeword #1. For both codewords #0 and #1, the PDSCH BLER using the transport format indicated by the respective median CQI<sub>0</sub> - 1 and median CQI<sub>1</sub> - 1 shall be less than or equal to 0.1. Furthermore, for both codewords #0 and #1, the PDSCH BLER using the transport format indicated by the respective median CQI<sub>0</sub> + 1 and median CQI<sub>1</sub> + 1 shall be greater than or equal to 0.1.

Table 9.9.1.3.1-1: PUCCH 1-1 static test (FDD)

Parameter	Unit	Test 1		Test 2	
Bandwidth	MHz	10			
PDSCH transmission mode		4			
Downlink power allocation	$\rho_A$	dB		-6	
	$\rho_B$	dB		-6	
	$\sigma$	dB		0	
Propagation condition and antenna configuration		Clause B.1 (4 x 4)			
CodeBookSubsetRestriction bitmap		0x0002 0000 0000 0000			
SNR (Note 2)	dB	5	6	11	12
$\hat{I}_{or}^{(j)}$	dB[mW/15kHz]	-93	-92	-87	-86
$N_{oc}^{(j)}$	dB[mW/15kHz]	-98		-98	
Max number of HARQ transmissions		1			
Physical channel for CQI/PMI reporting		PUCCH Format 2			
PUCCH Report Type for CQI/PMI		2			
PUCCH Report Type for RI		3			
Reporting periodicity	ms	$N_{pd} = 5$			
<i>cqi-pmi-ConfigurationIndex</i>		6			
<i>ri-ConfigIndex</i>		1 (Note 3)			
Note 1:	Reference measurement channel RC.21 FDD according to Table A.4-1 with one sided dynamic OCNG Pattern OP.1 FDD as described in Annex A.5.1.1.				
Note 2:	For each test, the minimum requirements shall be fulfilled for at least one of the two SNR(s) and the respective wanted signal input level.				
Note 3:	It is intended to have UL collisions between RI reports and HARQ-ACK, since the RI reports shall not be used by the eNB in this test.				

## 9.9.1.3.2 TDD

The following requirements apply to UE Category  $\geq 5$ . For the parameters specified in table 9.9.1.3.2-1, and using the downlink physical channels specified in tables C.3.2-1 and C.3.2-2, the reported offset level of the wideband spatial differential CQI for codeword #1 (Table 7.2-2 in TS 36.213 [6]) shall be used to determine the wideband CQI index for codeword #1 as

$$\text{wideband CQI}_1 = \text{wideband CQI}_0 - \text{Codeword 1 offset level}$$

The wideband CQI<sub>1</sub> shall be within the set {median CQI<sub>1</sub> - 1, median CQI<sub>1</sub>, median CQI<sub>1</sub> + 1} for more than 90% of the time, where the resulting wideband values CQI<sub>1</sub> shall be used to determine the median CQI values for codeword #1. For both codewords #0 and #1, the PDSCH BLER using the transport format indicated by the respective median CQI<sub>0</sub> - 1 and median CQI<sub>1</sub> - 1 shall be less than or equal to 0.1. Furthermore, for both codewords #0 and #1, the PDSCH BLER

using the transport format indicated by the respective median  $CQI_0 + 1$  and median  $CQI_1 + 1$  shall be greater than or equal to 0.1.

**Table 9.9.1.3.2-1: PUCCH 1-1 static test (TDD)**

Parameter	Unit	Test 1		Test 2	
Bandwidth	MHz			10	
PDSCH transmission mode				4	
Uplink downlink configuration				2	
Special subframe configuration				4	
Downlink power allocation	$\rho_A$	dB			-6
	$\rho_B$	dB			-6
	$\sigma$	dB			0
Propagation condition and antenna configuration		Clause B.1 (4x4)			
CodeBookSubsetRestriction bitmap		0x0002 0000 0000 0000			
SNR (Note 2)	dB	5	6	11	12
$\hat{I}_{or}^{(j)}$	dB[mW/15kHz]	-93	-92	-87	-86
$N_{oc}^{(j)}$	dB[mW/15kHz]	-98		-98	
Max number of HARQ transmissions		1			
Physical channel for CQI/PMI reporting		PUSCH (Note 3)			
PUCCH Report Type		2			
Reporting periodicity	ms	$N_{pd} = 5$			
<i>cqi-pmi-ConfigurationIndex</i>		3			
<i>ri-ConfigIndex</i>		805 (Note 4)			
ACK/NACK feedback mode		Multiplexing			
Note 1:	Reference measurement channel RC.21 TDD according to Table A.4-1 with one sided dynamic OCNG Pattern OP.1 TDD as described in Annex A.5.2.1.				
Note 2:	For each test, the minimum requirements shall be fulfilled for at least one of the two SNR(s) and the respective wanted signal input level.				
Note 3:	To avoid collisions between CQI/PMI reports and HARQ-ACK it is necessary to report both on PUSCH instead of PUCCH. PDCCH DCI format 0 shall be transmitted in downlink SF#3 and #8 to allow periodic CQI/PMI to multiplex with the HARQ-ACK on PUSCH in uplink subframe SF#7 and #2.				
Note 4:	RI reporting interval is set to the maximum allowable length of 160ms to minimise collisions between RI, CQI/PMI and HARQ-ACK reports. In the case when all three reports collide, it is expected that CQI/PMI reports will be dropped, while RI and HARQ-ACK will be multiplexed. At eNB, CQI report collection shall be skipped every 160ms during performance verification.				

#### 9.9.1.4 Minimum requirement PUCCH 1-1 with Rank 3 (CSI Reference Symbols)

The minimum requirements for dual codeword transmission are defined in terms of a reporting spread of the wideband CQI value for codeword #1, and their BLER performance using the transport format indicated by the reported CQI median of codeword #0 and codeword #1. The precoding used at the transmitter is a fixed precoding matrix specified by the bitmap parameter *codebookSubsetRestriction*. The propagation condition assumed for the minimum performance requirement is defined in subclause B.1.

##### 9.9.1.4.1 FDD

The following requirements apply to UE Category  $\geq 5$ . For the parameters specified in table 9.9.1.4.1-1, and using the downlink physical channels specified in tables C.3.2-1 and C.3.2-2, the reported offset level of the wideband spatial differential CQI for codeword #1 (Table 7.2-2 in TS 36.213 [6]) shall be used to determine the wideband CQI index for codeword #1 as

$$\text{wideband } CQI_1 = \text{wideband } CQI_0 - \text{Codeword 1 offset level}$$

The wideband  $CQI_1$  shall be within the set  $\{\text{median } CQI_1 - 1, \text{median } CQI_1, \text{median } CQI_1 + 1\}$  for more than 90% of the time, where the resulting wideband values  $CQI_1$  shall be used to determine the median CQI values for codeword #1. For both codewords #0 and #1, the PDSCH BLER using the transport format indicated by the respective median  $CQI_0 - 1$  and median  $CQI_1 - 1$  shall be less than or equal to 0.1. Furthermore, for both codewords #0 and #1, the PDSCH BLER using the transport format indicated by the respective median  $CQI_0 + 1$  and median  $CQI_1 + 1$  shall be greater than or equal to 0.1.

**Table 9.9.1.4.1-1: PUCCH 1-1 static test (FDD)**

Parameter	Unit	Test 1		Test 2	
Bandwidth	MHz			10	
PDSCH transmission mode				9	
Downlink power allocation	$\rho_A$	dB		0	
	$\rho_B$	dB		0	
	$\rho_C$	dB		-3	
	$\sigma$	dB		-3	
Cell-specific reference signals		Antenna ports 0, 1			
CSI reference signals		Antenna ports 15, ..., 18			
CSI-RS periodicity and subframe offset $T_{\text{CSI-RS}} / \Delta_{\text{CSI-RS}}$		5/1			
CSI reference signal configuration		0			
Propagation condition and antenna configuration		Clause B.1 (4 x 4)			
Beamforming Model		As specified in Section B.4.3			
CodeBookSubsetRestriction bitmap		0x0000 0020 0000 0000			
SNR (Note 2)	dB	5	6	11	12
$\hat{I}_{or}^{(j)}$	dB[mW/15kHz]	-93	-92	-87	-86
$N_{oc}^{(j)}$	dB[mW/15kHz]	-98		-98	
Max number of HARQ transmissions		1			
Physical channel for CQI/PMI reporting		PUSCH (Note3)			
PUCCH Report Type for CQI/PMI		2			
Physical channel for RI reporting		PUCCH Format 2			
PUCCH Report Type for RI		3			
Reporting periodicity	ms	$N_{\text{pd}} = 5$			
CQI delay	ms	8			
<i>cqi-pmi-ConfigurationIndex</i>		2			
<i>ri-ConfigIndex</i>		1			
Note 1:	Reference measurement channel RC.22 FDD according to Table A.4-1 with one sided dynamic OCNG Pattern OP.1 FDD as described in Annex A.5.1.1.				
Note 2:	For each test, the minimum requirements shall be fulfilled for at least one of the two SNR(s) and the respective wanted signal input level.				
Note 3:	To avoid collisions between CQI/PMI reports and HARQ-ACK it is necessary to report both on PUSCH instead of PUCCH. PDCCH DCI format 0 shall be transmitted in downlink SF#1 and #6 to allow periodic CQI/PMI to multiplex with the HARQ-ACK on PUSCH in uplink SF#0 and #5.				

#### 9.9.1.4.2 TDD

The following requirements apply to UE Category  $\geq 5$ . For the parameters specified in table 9.9.1.4.2-1, and using the downlink physical channels specified in tables C.3.2-1 and C.3.2-2, the reported offset level of the wideband spatial differential CQI for codeword #1 (Table 7.2-2 in TS 36.213 [6]) shall be used to determine the wideband CQI index for codeword #1 as

$$\text{wideband } CQI_1 = \text{wideband } CQI_0 - \text{Codeword 1 offset level}$$

The wideband  $CQI_1$  shall be within the set  $\{\text{median } CQI_1 - 1, \text{median } CQI_1, \text{median } CQI_1 + 1\}$  for more than 90% of the time, where the resulting wideband values  $CQI_1$  shall be used to determine the median CQI values for codeword #1. For both codewords #0 and #1, the PDSCH BLER using the transport format indicated by the respective median  $CQI_0 - 1$



and median  $CQI_1 - 1$  shall be less than or equal to 0.1. Furthermore, for both codewords #0 and #1, the PDSCH BLER using the transport format indicated by the respective median  $CQI_0 + 1$  and median  $CQI_1 + 1$  shall be greater than or equal to 0.1.

**Table 9.9.1.4.2-1: PUCCH 1-1 static test (TDD)**

Parameter	Unit	Test 1		Test 2	
Bandwidth	MHz	10			
PDSCH transmission mode		9			
Uplink downlink configuration		2			
Special subframe configuration		4			
Downlink power allocation	$\rho_A$	dB	0		
	$\rho_B$	dB	0		
	$\rho_C$	dB	-3		
	$\sigma$	dB	-3		
CRS reference signals		Antenna ports 0, 1			
CSI reference signals		Antenna ports 15, ..., 18			
CSI-RS periodicity and subframe offset $T_{CSI-RS} / \Delta_{CSI-RS}$		5/3			
CSI reference signal configuration		0			
Propagation condition and antenna configuration		Clause B.1 (4 x 4)			
Beamforming Model		As specified in Section B.4.3			
CodeBookSubsetRestriction bitmap		0x0000 0020 0000 0000			
SNR (Note 2)	dB	5	6	11	12
$\hat{I}_{or}^{(j)}$	dB[mW/15kHz]	-93	-92	-87	-86
$N_{oc}^{(j)}$	dB[mW/15kHz]	-98		-98	
Max number of HARQ transmissions		1			
Physical channel for CQI/PMI reporting		PUSCH (Note 3)			
PUCCH Report Type for CQI/PMI		2			
Physical channel for RI reporting		PUSCH			
PUCCH Report Type for RI		3			
Reporting periodicity	ms	$N_{pd} = 5$			
CQI delay	ms	10 or 11			
<i>cqi-pmi-ConfigurationIndex</i>		3			
<i>ri-ConfigIndex</i>		805 (Note 4)			
ACK/NACK feedback mode		Multiplexing			
Note 1:	Reference measurement channel RC.22 TDD according to Table A.4-1 with one sided dynamic OCNB Pattern OP.1 TDD as described in Annex A.5.2.1.				
Note 2:	For each test, the minimum requirements shall be fulfilled for at least one of the two SNR(s) and the respective wanted signal input level.				
Note 3:	To avoid collisions between CQI/PMI reports and HARQ-ACK it is necessary to report both on PUSCH instead of PUCCH. PDCCCH DCI format 0 shall be transmitted in downlink SF#3 and #8 to allow periodic CQI/PMI to multiplex with the HARQ-ACK on PUSCH in uplink SF#7 and #2.				
Note 4:	RI reporting interval is set to the maximum allowable length of 160ms to minimise collisions between RI, CQI/PMI and HARQ-ACK reports. In the case when all three reports collide, it is expected that CQI/PMI reports will be dropped, while RI and HARQ-ACK will be multiplexed. At eNB, CQI report collection shall be skipped every 160ms during performance verification.				

## 9.9.2 CQI reporting definition under fading conditions

### 9.9.2.1 Minimum requirement PUCCH 1-0 (Cell-Specific Reference Symbol) for enhanced receiver Type A

The purpose of the test is to verify that the reporting of the channel quality is based on the receiver of the enhanced Type A. Performance requirements are specified in terms of the relative increase of the throughput obtained when the transport format is that indicated by the reported CQI subject to an interference model compared to the case with a

white Gaussian noise model, and a requirement on the minimum BLER of the transmitted transport formats indicated by the reported CQI subject to an interference model.

#### 9.9.2.1.1 FDD

For the parameters specified in Table 9.9.2.1.1-1, and using the downlink physical channels specified in Annex C, the minimum requirements are specified in Table 9.9.2.1.1-2 and by the following

- a) the ratio of the throughput obtained when transmitting the transport format indicated by each reported wideband CQI index subject to an interference source with specified DIP and that obtained when transmitting the transport format indicated by each reported wideband CQI index subject to a white Gaussian noise source shall be  $\geq \gamma$ ;
- b) when transmitting the transport format indicated by each reported wideband CQI index subject to an interference source with specified DIP, the average BLER for the indicated transport formats shall be greater than or equal to 2%.

Table 9.9.2.1.1-1 Fading test for single antenna (FDD)

Parameter	Unit	Cell 1	Cell 2
Bandwidth	MHz	10 MHz	
Transmission mode		1 (port 0)	
Cyclic Prefix		Normal	Normal
Cell ID		0	1
SINR (Note 8)	dB	-4	N/A
$N_{oc}^{(j)}$	dB[mW/15kHz]	-98	N/A
Propagation channel		EPA5	Static (Note 7)
Correlation and antenna configuration		Low (1 x 4)	(1 x 4)
DIP (Note 4)	dB	N/A	-0.41
Reference measurement channel		Note 2	R.2 FDD
Reporting mode		PUCCH 1-0	N/A
Reporting periodicity	ms	$N_{pd} = 2$	N/A
CQI delay	ms	8	N/A
Physical channel for CQI reporting		PUSCH (Note 3)	N/A
PUCCH Report Type		4	N/A
<i>cqi-pmi-ConfigurationIndex</i>		1	N/A
Max number of HARQ transmissions		1	N/A
Note 1:	If the UE reports in an available uplink reporting instance at subframe SF#n based on CQI estimation at a downlink SF not later than SF#(n-4), this reported wideband CQI cannot be applied at the eNB downlink before SF#(n+4)		
Note 2:	Reference measurement channel RC.1 FDD according to Table A.4-1 for Category 2-8 with one sided dynamic OCNG Pattern OP.1 FDD as described in Annex A.5.1.1 and RC.4 FDD according to Table A.4-1 for Category 1 with one/two sided dynamic OCNG Pattern OP.1/2 FDD as described in Annex A.5.1.1/2.		
Note 3:	To avoid collisions between CQI reports and HARQ-ACK it is necessary to report both on PUSCH instead of PUCCH. PDCCH DCI format 0 shall be transmitted in downlink SF#1, #3, #7 and #9 to allow periodic CQI to multiplex with the HARQ-ACK on PUSCH in uplink subframe SF#5, #7, #1 and #3.		
Note 4:	The respective received power spectral density of each interfering cell relative to $N_{oc}^{(j)}$ is defined by its associated DIP value as specified in clause B.5.1.		
Note 5:	Two cells are considered in which Cell 1 is the serving cell and Cell 2 is the interfering cell. The number of the CRS ports in both cells is the same. Interfering cell is fully loaded.		
Note 6:	Both cells are time-synchronous.		
Note 7:	Static channel is used for the interference model. In case for white Gaussian noise model Cell 2 is not present.		
Note 8:	SINR corresponds to $E_s/N_{oc}^{(j)}$ of Cell 1 as defined in clause 8.1.1.		

Table 9.9.2.1.1-2 Minimum requirement (FDD)

$\gamma$	1.8
UE Category	$\geq 1$

## 9.9.2.1.2 TDD

For the parameters specified in Table 9.9.2.1.2-1, and using the downlink physical channels specified in Annex C, the minimum requirements are specified in 9.9.2.1.2-2 and by the following

- a) the ratio of the throughput obtained when transmitting the transport format indicated by each reported wideband CQI index subject to an interference source with specified DIP and that obtained when transmitting the transport format indicated by each reported wideband CQI index subject to a white Gaussian noise source shall be  $\geq \gamma$ ;
- b) when transmitting the transport format indicated by each reported wideband CQI index subject to an interference source with specified DIP, the average BLER for the indicated transport formats shall be greater than or equal to 2%.

Table 9.9.2.1.2-1 Fading test for single antenna (TDD)

Parameter	Unit	Cell 1	Cell 2
Bandwidth	MHz	10 MHz	
Transmission mode		1 (port 0)	
Uplink downlink configuration		2	
Special subframe configuration		4	
Cyclic Prefix		Normal	Normal
Cell ID		0	1
SINR (Note 8)	dB	-4	N/A
$N_{oc}^{(j)}$	dB[mW/15kHz]	-98	-98
Propagation channel		EPA5	Static (Note 7)
Correlation and antenna configuration		Low (1 x 4)	(1 x 4)
DIP (Note 4)	dB	N/A	-0.41
Reference measurement channel		Note 2	R.2A TDD
Reporting mode		PUCCH 1-0	N/A
Reporting periodicity	ms	$N_{pd} = 5$	N/A
CQI delay	ms	10 or 11	N/A
Physical channel for CQI reporting		PUSCH (Note 3)	N/A
PUCCH Report Type		4	N/A
<i>cqi-pmi-ConfigurationIndex</i>		3	N/A
Max number of HARQ transmissions		1	N/A
ACK/NACK feedback mode		Multiplexing	N/A
<p>Note 1: If the UE reports in an available uplink reporting instance at subframe SF#n based on CQI estimation at a downlink SF not later than SF#(n-4), this reported wideband CQI cannot be applied at the eNB downlink before SF#(n+4)</p> <p>Note 2: Reference measurement channel RC.1 TDD according to Table A.4-1 for Category 2-8 with one sided dynamic OCNG Pattern OP.1 TDD as described in Annex A.5.2.1 and RC.4 TDD according to Table A.4-1 for Category 1 with one/two sided dynamic OCNG Pattern OP.1/2 TDD as described in Annex A.5.2.1/2.</p> <p>Note 3: To avoid collisions between CQI reports and HARQ-ACK it is necessary to report both on PUSCH instead of PUCCH. PDCCH DCI format 0 shall be transmitted in downlink SF#3 and #8 to allow periodic CQI to multiplex with the HARQ-ACK on PUSCH in uplink subframe SF#7 and #2.</p> <p>Note 4: The respective received power spectral density of each interfering cell relative to <math>N_{oc}^{(j)}</math> is defined by its associated DIP value as specified in clause B.5.1.</p> <p>Note 5: Two cells are considered in which Cell 1 is the serving cell and Cell 2 is the interfering cell. The number of the CRS ports in both cells is the same. Interfering cell is fully loaded.</p> <p>Note 6: Both cells are time-synchronous.</p> <p>Note 7: Static channel is used for the interference model. In case for white Gaussian noise model Cell 2 is not present.</p> <p>Note 8: SINR corresponds to <math>E_s/N_{oc}^{(j)}</math> of Cell 1 as defined in clause 8.1.1.</p>			

Table 9.3.5.1.2-2 Minimum requirement (TDD)

$\gamma$	1.8
UE Category	$\geq 1$

### 9.9.2.2 Minimum requirement PUCCH 1-1 (CSI Reference Symbol) for enhanced receiver Type A

The purpose of the test is to verify that the reporting of the channel quality is based on the receiver of the enhanced Type A. Performance requirements are specified in terms of the relative increase of the throughput obtained when the transport format is that indicated by the reported CQI subject to an interference model compared to the case with a white Gaussian noise model, and a requirement on the minimum BLER of the transmitted transport formats indicated by the reported CQI subject to an interference model.

#### 9.9.2.2.1 FDD

For the parameters specified in Table 9.9.2.2.1-1, and using the downlink physical channels specified in Annex C, the minimum requirements are specified in Table 9.9.2.2.1-2 and by the following

- a) the ratio of the throughput obtained when transmitting the transport format indicated by each reported wideband CQI index subject to an interference source with specified DIP and that obtained when transmitting the transport format indicated by each reported wideband CQI index subject to a white Gaussian noise source shall be  $\geq \gamma$ ;
- b) when transmitting the transport format indicated by each reported wideband CQI index subject to an interference source with specified DIP, the average BLER for the indicated transport formats shall be greater than or equal to 2%.

**Table 9.9.2.2.1-1 Fading test for single antenna (FDD)**

Parameter	Unit	Cell 1	Cell 2
Bandwidth	MHz	10 MHz	
Transmission mode		9	
Cyclic Prefix		Normal	Normal
Cell ID		0	1
SINR (Note 8)	dB	-4	N/A
$N_{oc}^{(j)}$	dB[mW/15kHz]	-98	N/A
Propagation channel		EPA5	Static (Note 7)
Correlation and antenna configuration		Low (2 x 4)	(1 x 4)
Beamforming Model		As specified in Section B.4.3 (Note 9, 10)	N/A
DIP (Note 4)	dB	N/A	-0.41
Cell-specific reference signals		Antenna ports 0,1	Antenna port 0
CSI reference signals		Antenna ports 15,16	N/A
CSI-RS periodicity and subframe offset		5/1	N/A
CSI-RS reference signal configuration		2	N/A
Zero-power CSI-RS configuration $i_{CSI-RS}$ / ZeroPowerCSI-RS bitmap	Subframes / bitmap	N/A	1 / 001000000000 000
CodeBookSubsetRestriction bitmap		001111	N/A
Reference measurement channel		Note 2	R.2 FDD
Reporting mode		PUCCH 1-1	N/A
Reporting periodicity	ms	$N_{pd} = 5$	N/A
CQI delay	ms	8	N/A
Physical channel for CQI/PMI reporting		PUSCH (Note 3)	N/A
PUCCH Report Type for CQI/PMI		2	N/A
PUCCH channel for RI reporting		PUCCH Format 2	N/A
PUCCH Report Type for RI		3	N/A
$cqi-pmi-ConfigurationIndex$		2	N/A
$ri-ConfigIndex$		1	N/A
Max number of HARQ transmissions		1	N/A



Note 1:	If the UE reports in an available uplink reporting instance at subframe SF#n based on CQI estimation at a downlink SF not later than SF#(n-4), this reported wideband CQI cannot be applied at the eNB downlink before SF#(n+4)
Note 2:	Reference measurement channel RC.11 FDD according to Table A.4-1 with one sided dynamic OCNG Pattern OP.1 FDD as described in Annex A.5.1.1.
Note 3:	To avoid collisions between CQI/ PMI reports and HARQ-ACK it is necessary to report both on PUSCH instead of PUCCH. PDCCH DCI format 0 shall be transmitted in downlink SF#1 and #6 to allow periodic CQI/ PMI to multiplex with the HARQ-ACK on PUSCH in uplink subframe SF#0 and #5.
Note 4:	The respective received power spectral density of each interfering cell relative to $N_{oc}$ is defined by its associated DIP value as specified in clause B.5.1.
Note 5:	Two cells are considered in which Cell 1 is the serving cell and Cell 2 is the interfering cell. Interfering cell is fully loaded.
Note 6:	Both cells are time-synchronous.
Note 7:	Static channel is used for the interference model. In case for white Gaussian noise model Cell 2 is not present.
Note 8:	SINR corresponds to $E_s/N_{oc}$ of Cell 1 as defined in clause 8.1.1.
Note 9:	The precoder in clause B.4.3 follows UE recommended PMI.
Note 10:	If the UE reports in an available uplink reporting instance at subframe SF#n based on PMI estimation at a downlink SF not later than SF#(n-4), this reported PMI cannot be applied at the eNB downlink before SF#(n+4).

**Table 9.9.2.2-1-2 Minimum requirement (FDD)**

$\gamma$	1.8
UE Category	$\geq 2$

**9.9.2.2.2 TDD**

For the parameters specified in Table 9.9.2.2-1, and using the downlink physical channels specified in Annex C, the minimum requirements are specified in 9.9.2.2-2 and by the following

- the ratio of the throughput obtained when transmitting the transport format indicated by each reported wideband CQI index subject to an interference source with specified DIP and that obtained when transmitting the transport format indicated by each reported wideband CQI index subject to a white Gaussian noise source shall be  $\geq \gamma$ ;
- when transmitting the transport format indicated by each reported wideband CQI index subject to an interference source with specified DIP, the average BLER for the indicated transport formats shall be greater than or equal to 2%.

**Table 9.9.2.2.2-1 Fading test for single antenna (TDD)**

Parameter	Unit	Cell 1	Cell 2
Bandwidth	MHz	10 MHz	
Transmission mode		9	
Uplink downlink configuration		2	
Special subframe configuration		4	
Cyclic Prefix		Normal	Normal
Cell ID		0	1
SINR (Note 8)	dB	[-4]	N/A
$N_{oc}^{(j)}$	dB[mW/15kHz]	-98	-98
Propagation channel		EPA5	Static (Note 7)
Correlation and antenna configuration		Low (2 x 4)	(1 x 4)
Beamforming Model		As specified in Section B.4.3 (Note 10, 11)	N/A
DIP (Note 4)	dB	N/A	-0.41
Cell-specific reference signals		Antenna ports 0,1	Antenna port 0
CSI reference signals		Antenna ports 15,16	N/A
CSI-RS periodicity and subframe offset		5/3	N/A
CSI-RS reference signal configuration		2	N/A
Zero-power CSI-RS configuration $I_{CSI-RS}$ / ZeroPowerCSI-RS bitmap	Subframes / bitmap	N/A	3 / 001000000000 0000
CodeBookSubsetRestriction bitmap		001111	N/A
Reference measurement channel		Note 2	R.2A TDD
Reporting mode		PUCCH 1-1	N/A
Reporting periodicity	ms	$N_{pd} = 5$	N/A
CQI delay	ms	10	N/A
Physical channel for CQI/PMI reporting		PUSCH (Note 3)	N/A
PUCCH Report Type for CQI/PMI		2	N/A
Physical channel for RI reporting		PUCCH Format 2	N/A
PUCCH Report Type for RI		3	N/A
$cqi-pmi-ConfigurationIndex$		3	N/A
$ri-ConfigIndex$		805 (Note 9)	N/A
Max number of HARQ transmissions		1	N/A
ACK/NACK feedback mode		Multiplexing	N/A

Note 1:	If the UE reports in an available uplink reporting instance at subframe SF#n based on CQI estimation at a downlink SF not later than SF#(n-4), this reported wideband CQI cannot be applied at the eNB downlink before SF#(n+4)
Note 2:	Reference measurement channel RC.11 TDD according to Table A.4-1 with one sided dynamic OCNG Pattern OP.1 TDD as described in Annex A.5.2.1.
Note 3:	To avoid collisions between CQI/ PMI reports and HARQ-ACK it is necessary to report both on PUSCH instead of PUCCH. PDCCH DCI format 0 shall be transmitted in downlink SF#3 and #8 to allow periodic CQI/ PMI to multiplex with the HARQ-ACK on PUSCH in uplink subframe SF#2 and #7.
Note 4:	The respective received power spectral density of each interfering cell relative to $N_{oc}$ is defined by its associated DIP value as specified in clause B.5.1.
Note 5:	Two cells are considered in which Cell 1 is the serving cell and Cell 2 is the interfering cell. Interfering cell is fully loaded.
Note 6:	Both cells are time-synchronous.
Note 7:	Static channel is used for the interference model. In case for white Gaussian noise model Cell 2 is not present.
Note 8:	SINR corresponds to $E_s/N_{oc}$ of Cell 1 as defined in clause 8.1.1.
Note 9:	RI reporting interval is set to the maximum allowable length of 160ms to minimise collisions between RI, CQI/PMI and HARQ-ACK reports. In the case when all three reports collide, it is expected that CQI/PMI reports will be dropped, while RI and HARQ-ACK will be multiplexed. At eNB, CQI report collection shall be skipped every 160ms during performance verification and the reported CQI in subframe SF#7 of the previous frame is applied in downlink subframes until a new CQI (after CQI/PMI dropping) is available.
Note 10:	The precoder in clause B.4.3 follows UE recommended PMI.
Note 11:	If the UE reports in an available uplink reporting instance at subframe SF#n based on PMI estimation at a downlink SF not later than SF#(n-4), this reported PMI cannot be applied at the eNB downlink before SF#(n+4).

Table 9.9.2.2-2 Minimum requirement (TDD)

$\gamma$	1.8
UE Category	$\geq 2$

### 9.9.3 Reporting of Precoding Matrix Indicator (PMI) for 4Rx UE

The minimum performance requirements of PMI reporting are defined based on the precoding gain, expressed as the relative increase in throughput when the transmitter is configured according to the UE reports compared to the case when the transmitter is using random precoding, respectively. When the transmitter uses random precoding, for each PDSCH allocation a precoder is randomly generated and applied to the PDSCH. A fixed transport format (FRC) is configured for all requirements.

The requirements for transmission mode 9 with 8 TX are specified in terms of the ratio

$$\gamma = \frac{t_{ue, follow 1, follow 2}}{t_{rd 1, rd 2}}$$

In the definition of  $\gamma$ , for PUSCH 3-1 single PMI  $t_{follow 1, follow 2}$  is 70% of the maximum throughput obtained at

$SNR_{follow 1, follow 2}$  using the precoders configured according to the UE reports, and  $t_{rd 1, rd 2}$  is the throughput measured at  $SNR_{follow 1, follow 2}$  with random precoding.

### 9.9.3.1 Minimum requirement PUSCH 3-1 (CSI Reference Symbol)

#### 9.9.3.1.1 TDD

For the parameters specified in Table 9.9.3.1.1-1, and using the downlink physical channels specified in Annex C.3.2, the minimum requirements are specified in Table 9.9.3.1.1-2.

Table 9.9.3.1.1-1: PMI test for single-layer (TDD)

Parameter	Unit	Test 1	
Bandwidth	MHz	10	
Transmission mode		9	
Uplink downlink configuration		1	
Special subframe configuration		4	
Propagation channel		EVA5	
Precoding granularity	PRB	50	
Antenna configuration		8 x 4	
Correlation modeling		High, Cross polarized	
Cell-specific reference signals		Antenna ports 0,1	
CSI reference signals		Antenna ports 15,...,22	
Beamforming model		Annex B.4.3	
CSI-RS periodicity and subframe offset $T_{\text{CSI-RS}} / \Delta_{\text{CSI-RS}}$		5/4	
CSI-RS reference signal configuration		0	
CodeBookSubsetRestriction bitmap		0x0000 0000 001F FFE0 0000 0000 FFFF	
Downlink power allocation	$\rho_A$	dB	0
	$\rho_B$	dB	0
	$\rho_C$	dB	-6
	$\sigma$	dB	-3
$N_{oc}^{(j)}$	dB[mW/15kHz]	-98	
Reporting mode		PUSCH 3-1	
Reporting interval	ms	5	
PMI delay (Note 2)	ms	10	
Measurement channel		R,45-2 TDD	
OCNG Pattern		OP.1 TDD	
Max number of HARQ transmissions		4	
Redundancy version coding sequence		{0,0,1,2}	
ACK/NACK feedback mode		Multiplexing	
Note 1:	For random precoder selection, the precoder shall be updated in each TTI (1 ms granularity).		
Note 2:	If the UE reports in an available uplink reporting instance at subframe SF#n based on PMI estimation at a downlink SF not later than SF#(n-4), this reported PMI cannot be applied at the eNB downlink before SF#(n+4).		
Note 3:	PDCCH DCI format 0 with a trigger for aperiodic CQI shall be transmitted in downlink SF#4 and #9 to allow aperiodic CQI/PMI/RI to be transmitted on uplink SF#3 and #8.		
Note 4:	Randomization of the principle beam direction shall be used as specified in B.2.3A.4		

**Table 9.9.3.1.1-2: Minimum requirement (TDD)**

Parameter	Test 1
$\gamma$	2.5
UE Category	$\geq 2$

## 9.9.4 Reporting of Rank Indicator (RI)

The purpose of this test for 4Rx UEs is to verify that the reported rank indicator accurately represents the channel rank. The accuracy of RI (CQI) reporting is determined by the relative increase of the throughput obtained when transmitting based on the reported rank compared to the case for which a fixed rank is used for transmission. Transmission mode 4 is used with the specified CodebookSubSetRestriction in section 9.9.4.1, transmission mode 9 is used with the specified CodebookSubSetRestriction in section 9.9.4.2.

For the fixed rank 1 transmission with 2 Tx ports the RI and PMI reporting is restricted to two single-layer precoders, For fixed rank 2 transmission with 2 Tx ports the RI and PMI reporting is restricted to one two-layer precoder. For the follow RI transmission for rank 1 and 2 and 2 Tx ports the RI and PMI reporting is restricted to select the union of these precoders.

For the fixed rank 2 transmission with 4 Tx ports the RI and PMI reporting is restricted to any 2 Layer precoder, for the follow RI transmission the RI and PMI reporting is not restricted at all.

Channels with low and high correlation are used to ensure that RI reporting reflects the channel condition.

### 9.9.4.1 Minimum requirement (Cell-Specific Reference Symbols)

#### 9.9.4.1.1 FDD

The minimum performance requirement in Table 9.9.4.1.1-2 is defined as

- a) The ratio of the throughput obtained when transmitting based on UE reported RI and that obtained when transmitting with fixed rank 1 shall be  $\geq \gamma_1$ ;
- b) The ratio of the throughput obtained when transmitting based on UE reported RI and that obtained when transmitting with fixed rank 2 shall be  $\geq \gamma_2$ ;

For the parameters specified in Table 9.9.4.1.1-1, and using the downlink physical channels specified in Annex C.3.2, the minimum requirements are specified in Table 9.9.4.1.1-2.

Table 9.9.4.1.1-1: RI Test (FDD)

Parameter	Unit	Test 1	Test 2	Test 3	Test 4
Bandwidth	MHz	10			
PDSCH transmission mode		4			
Downlink power allocation	$\rho_A$	dB	-3		-6
	$\rho_B$	dB	-3		-6
	$\sigma$	dB	0		3
Propagation condition and antenna configuration		2 x 4 EPA5			4 x 4 EPA5
Cell-specific reference signals		Antenna ports 0, 1			Antenna ports 0-3
CodeBookSubsetRestriction bitmap		000011 for fixed RI = 1 010000 for fixed RI = 2 010011 for UE reported RI			Note 6
Antenna correlation		Low	Low	High	Low
RI configuration		Fixed RI=2 and follow RI	Fixed RI=1 and follow RI	Fixed RI=1 and follow RI	Fixed RI=2 and follow RI
SNR	dB	-4	16	16	25
$N_{oc}^{(j)}$	dB[mW/15kHz]	-98	-98	-98	-98
$\hat{I}_{or}^{(j)}$	dB[mW/15kHz]	-102	-82	-82	-73
Maximum number of HARQ transmissions		1			
Reporting mode		PUCCH 1-1 (Note 4)			
Physical channel for CQI/PMI reporting		PUCCH Format 2			
PUCCH Report Type for CQI/PMI		2			
Physical channel for RI reporting		PUSCH (Note 3)			
PUCCH Report Type for RI		3			
Reporting periodicity	ms	$N_{pd}=5$			
PMI and CQI delay	ms	8			
<i>cqi-pmi-ConfigurationIndex</i>		6			
<i>ri-ConfigurationInd</i>		1 (Note 5)			
Note 1:	If the UE reports in an available uplink reporting instance at subframe SF#n based on PMI and CQI estimation at a downlink subframe not later than SF#(n-4), this reported PMI and wideband CQI cannot be applied at the eNB downlink before SF#(n+4).				
Note 2:	Reference measurement channel RC.2 FDD / RC.21 FDD respectively for Test 1-3 / 4 according to Table A.4-1 with one sided dynamic OCN Pattern OP.1 FDD as described in Annex A.5.1.1.				
Note 3:	To avoid collisions between RI reports and HARQ-ACK it is necessary to report both on PUSCH instead of PUCCH. PDCCH DCI format 0 shall be transmitted in downlink SF#4 and #9 to allow periodic RI to multiplex with the HARQ-ACK on PUSCH in uplink subframe SF#8 and #3.				
Note 4:	The bit field for precoding information in DCI format 2 shall be mapped as: <ul style="list-style-type: none"> <li>For reported RI = 1 and PMI = 0 &gt;&gt; precoding information bit field index = 1</li> <li>For reported RI = 1 and PMI = 1 &gt;&gt; precoding information bit field index = 2</li> <li>For reported RI = 2 and PMI = 0 &gt;&gt; precoding information bit field index = 0</li> </ul>				
Note 5:	To avoid the ambiguity of TE behaviour when applying CQI and PMI during rank switching, RI reports are to be applied at the TE with one subframe delay in addition to Note 1 to align with CQI and PMI reports.				
Note 6:	The following precoders are allowed in Test 4: "0x0000 0000 FFFF 0000" for RI=2 "0xFFFF FFFF FFFF FFFF" for UE reported RI				

Table 9.9.4.1.1-2: Minimum requirement (FDD)

	Test 1	Test 2	Test 3	Test 4
$\gamma_1$	N/A	1.05	0.9	N/A
$\gamma_2$	1	N/A	N/A	1.1
UE Category	$\geq 2$	$\geq 2$	$\geq 2$	$\geq 5$



## 9.9.4.1.2 TDD

The minimum performance requirement in Table 9.9.4.1.2-2 is defined as

- The ratio of the throughput obtained when transmitting based on UE reported RI and that obtained when transmitting with fixed rank 1 shall be  $\geq \gamma_1$ ;
- The ratio of the throughput obtained when transmitting based on UE reported RI and that obtained when transmitting with fixed rank 2 shall be  $\geq \gamma_2$ ;

For the parameters specified in Table 9.9.4.1.2-1, and using the downlink physical channels specified in Annex C.3.2, the minimum requirements are specified in Table 9.9.4.1.2-2.

Table 9.9.4.1.2-1: RI Test (TDD)

Parameter	Unit	Test 1	Test 2	Test 3	Test 4
Bandwidth	MHz	10			
PDSCH transmission mode		4			
Downlink power allocation	$\rho_A$	dB	-3		-6
	$\rho_B$	dB	-3		-6
	$\sigma$	dB	0		3
Uplink downlink configuration		2			
Special subframe configuration		4			
Propagation condition and antenna configuration		2 x 4 EPA5			4 x 4 EPA5
Cell-specific reference signals		Antenna ports 0, 1			Antenna ports 0-3
CodeBookSubsetRestriction bitmap		000011 for fixed RI = 1 010000 for fixed RI = 2 010011 for UE reported RI			Note 4
Antenna correlation		Low	Low	High	Low
RI configuration		Fixed RI=2 and follow RI	Fixed RI= 1 and follow RI	Fixed RI=1 and follow RI	Fixed RI=2 and follow RI
SNR	dB	-4	16	16	25
$N_{oc}^{(j)}$	dB[mW/15kHz]	-98	-98	-98	-98
$\hat{I}_{or}^{(j)}$	dB[mW/15kHz]	-102	-82	-82	-73
Maximum number of HARQ transmissions		1			
Reporting mode		PUSCH 3-1 (Note 3)			
Reporting interval	ms	5			
PMI and CQI delay	ms	10 or 11			
ACK/NACK feedback mode		Bundling			
Note 1:	If the UE reports in an available uplink reporting instance at subframe SF#n based on PMI and CQI estimation at a downlink subframe not later than SF#(n-4), this reported PMI and wideband CQI cannot be applied at the eNB downlink before SF#(n+4).				
Note 2:	Reference measurement channel RC.2 TDD / RC.21 TDD respectively for Test 1-3 / 4 according to Table A.4-1 with one sided dynamic OCNG Pattern OP.1 TDD as described in Annex A.5.2.1.				
Note 3:	Reported wideband CQI and PMI are used and sub-band CQI is discarded.				
Note 4:	The following precoders are allowed in Test 4: "0x0000 0000 FFFF 0000" for RI=2 "0xFFFF FFFF FFFF FFFF" for UE reported RI				

Table 9.9.4.1.2-2: Minimum requirement (TDD)

	Test 1	Test 2	Test 3	Test 4
$\gamma_1$	N/A	1.05	0.9	N/A
$\gamma_2$	1	N/A	N/A	1.1
UE Category	$\geq 2$	$\geq 2$	$\geq 2$	$\geq 5$

## 9.9.4.2 Minimum requirement (CSI Reference Symbols)

### 9.9.4.2.1 FDD

The minimum performance requirement in Table 9.9.4.2.1-2 is defined as

- a) The ratio of the throughput obtained when transmitting based on UE reported RI and that obtained when transmitting with fixed rank 1 shall be  $\geq \gamma_1$ ;
- b) The ratio of the throughput obtained when transmitting based on UE reported RI and that obtained when transmitting with fixed rank 2 shall be  $\geq \gamma_2$ ;

For the parameters specified in Table 9.9.4.2.1-1, and using the downlink physical channels specified in Annex C.3.2, the minimum requirements are specified in Table 9.9.4.2.1-2.

Table 9.9.4.2.1-1: RI Test (FDD)

Parameter	Unit	Test 1	Test 2	Test 3	Test 4
Bandwidth	MHz		10		
PDSCH transmission mode			9		
Downlink power allocation	$\rho_A$	dB	0		
	$\rho_B$	dB	0		
	$\rho_C$	dB	0		-3
	$\sigma$	dB	0		-3
Propagation condition and antenna configuration			2 x 4 EPA5		4 x 4 EPA5
Cell-specific reference signals			Antenna ports 0		
Beamforming Model			As specified in Section B.4.3		
CSI reference signals			Antenna ports 15, 16		Antenna ports 15-18
CSI-RS periodicity and subframe offset $T_{\text{CSI-RS}} / \Delta_{\text{CSI-RS}}$			5/1		
CSI reference signal configuration			6		
CodeBookSubsetRestriction bitmap			000011 for fixed RI = 1 010000 for fixed RI = 2 010011 for UE reported RI		Note 5
Antenna correlation		Low	Low	High	Low
RI configuration		Fixed RI=2 and follow RI	Fixed RI=1 and follow RI	Fixed RI=1 and follow RI	Fixed RI=2 and follow RI
SNR	dB	-4	16	16	25
$N_{oc}^{(j)}$	dB[mW/15kHz]	-98	-98	-98	-98
$\hat{I}_{or}^{(j)}$	dB[mW/15kHz]	-102	-82	-82	-73
Maximum number of HARQ transmissions		1			
Reporting mode		PUCCH 1-1			
Physical channel for CQI/PMI reporting		PUSCH (Note 3)			
PUCCH Report Type for CQI/PMI		2			
Physical channel for RI reporting		PUCCH Format 2			
PUCCH Report Type for RI		3			
Reporting periodicity	ms	$N_{\text{pd}} = 5$			
PMI and CQI delay	ms	8			
<i>cqi-pmi-ConfigurationIndex</i>		2			
<i>ri-ConfigurationInd</i>		1 (Note 4)			
Note 1:	If the UE reports in an available uplink reporting instance at subframe SF#n based on PMI and CQI estimation at a downlink subframe not later than SF#(n-4), this reported PMI and wideband CQI cannot be applied at the eNB downlink before SF#(n+4).				
Note 2:	Reference measurement channel RC.9 FDD / RC.9B FDD respectively for Test 1-3 / 4 according to Table A.4-1 with one sided dynamic OCN Pattern OP.1 FDD as described in Annex A.5.1.1.				
Note 3:	To avoid collisions between CQI/ PMI reports and HARQ-ACK it is necessary to report both on PUSCH instead of PUCCH. PDCCH DCI format 0 shall be transmitted in downlink SF#1 and #6 to allow periodic CQI/ PMI to multiplex with the HARQ-ACK on PUSCH in uplink SF#0 and #5.				
Note 4:	To avoid the ambiguity of TE behaviour when applying CQI and PMI during rank switching, RI reports are to be applied at the TE with one subframe delay in addition to Note 1 to align with CQI and PMI reports.				
Note 5:	The following precoders are allowed in Test 4: "0x0000 0000 FFFF 0000" for RI=2 "0xFFFF FFFF FFFF FFFF" for UE reported RI				

**Table 9.9.4.2.1-2: Minimum requirement (FDD)**

	<b>Test 1</b>	<b>Test 2</b>	<b>Test 3</b>	<b>Test 4</b>
$\gamma_1$	N/A	1.05	0.9	N/A
$\gamma_2$	1	N/A	N/A	1.1
UE Category	$\geq 2$	$\geq 2$	$\geq 2$	$\geq 5$

#### 9.9.4.2.2 TDD

The minimum performance requirement in Table 9.9.4.2.2-2 is defined as

- a) The ratio of the throughput obtained when transmitting based on UE reported RI and that obtained when transmitting with fixed rank 1 shall be  $\geq \gamma_1$ ;
- b) The ratio of the throughput obtained when transmitting based on UE reported RI and that obtained when transmitting with fixed rank 2 shall be  $\geq \gamma_2$ ;

For the parameters specified in Table 9.9.4.2.1-1, and using the downlink physical channels specified in Annex C.3.2, the minimum requirements are specified in Table 9.9.4.2.2-2.

Table 9.9.4.2.2-1: RI Test (TDD)

Parameter	Unit	Test 1	Test 2	Test 3	Test 4
Bandwidth	MHz		10		
PDSCH transmission mode			9		
Downlink power allocation	$\rho_A$	dB	0		
	$\rho_B$	dB	0		
	$\rho_C$	dB	0		-3
	$\sigma$	dB	0		-3
Uplink downlink configuration			1		
Special subframe configuration			4		
Propagation condition and antenna configuration			2 x 4 EPA5		4 x 4 EPA5
Cell-specific reference signals			Antenna ports 0		
CSI reference signals			Antenna ports 15, 16		Antenna ports 15-18
Beamforming Model			As specified in Section B.4.3		
CSI reference signal configuration			4		
CSI-RS periodicity and subframe offset $T_{CSI-RS} / \Delta_{CSI-RS}$			5/4		
CodeBookSubsetRestriction bitmap			000011 for fixed RI = 1 010000 for fixed RI = 2 010011 for UE reported RI		Note 4
Antenna correlation		Low	Low	High	Low
RI configuration		Fixed RI=2 and follow RI	Fixed RI=1 and follow RI	Fixed RI=1 and follow RI	Fixed RI=2 and follow RI
SNR	dB	-4	16	16	25
$N_{oc}^{(j)}$	dB[mW/15kHz]	-98	-98	-98	-98
$\hat{I}_{or}^{(j)}$	dB[mW/15kHz]	-102	-82	-82	-73
Maximum number of HARQ transmissions		1			
Reporting mode		PUCCH 1-1			
Physical channel for CQI/ PMI reporting		PUSCH (Note 3)			
PUCCH report type for CQI/ PMI		2			
Physical channel for RI reporting		PUCCH Format 2			
Reporting periodicity	ms	$N_{pd} = 5$			
PMI and CQI delay	ms	10			
ACK/NACK feedback mode		Bundling			
<i>cqi-pmi-ConfigurationIndex</i>		4			
<i>ri-ConfigurationInd</i>		1			
Note 1:	If the UE reports in an available uplink reporting instance at subframe SF#n based on PMI and CQI estimation at a downlink subframe not later than SF#(n-4), this reported PMI and wideband CQI cannot be applied at the eNB downlink before SF#(n+4).				
Note 2:	Reference measurement channel RC.9 TDD / RC.9B TDD respectively for Test 1-3 / 4 according to Table A.4-1 with one sided dynamic OCNG Pattern OP.1 TDD as described in Annex A.5.2.1.				
Note 3:	To avoid collisions between CQI/PMI reports and HARQ-ACK it is necessary to report both on PUSCH instead of PUCCH. PDCCH DCI format 0 shall be transmitted in downlink SF#4 and #9 to allow periodic CQI/PMI to multiplex with the HARQ-ACK on PUSCH in uplink SF#3 and #8.				
Note 4:	The following precoders are allowed in Test 4: "0x0000 0000 FFFF 0000" for RI=2 "0xFFFF FFFF FFFF FFFF" for UE reported RI				

Table 9.9.4.2.2-2: Minimum requirement (TDD)

	Test 1	Test 2	Test 3	Test 4
$\gamma_1$	N/A	1.05	0.9	N/A
$\gamma_2$	1	N/A	N/A	1.1
UE Category	$\geq 2$	$\geq 2$	$\geq 2$	$\geq 5$

## 9.10 Reporting of CSI-RS Resource Indicator (CRI)

The purpose of this test is to verify that the reported CSI-RS Resource Indicator is accurate. The accuracy of CRI reporting for Tests in Section 9.10.1 is determined by:

- a) The ratio of the throughput obtained when transmitting based on the reported CRI and fixed precoder with multiple CSI-RS resources configured compared to that obtained when transmitting based on the fixed precoder with one CSI-RS resource configured:  $\gamma = \frac{t_{ue\_follow\_CRI\_fixed\_PMI}}{t_{fixed\_CRI\_fixed\_PMI}}$
- $t_{ue\_follow\_CRI\_fixed\_PMI}$  is [70%] of the maximum throughput obtained at  $SNR_{ue\_follow\_CRI\_fixed\_PMI}$  using fixed precoder and power scaling factor according to UE reported CRI value with multiple CSI-RS resources configured
  - $t_{fixed\_CRI\_fixed\_PMI}$  is throughput obtained at  $SNR_{ue\_follow\_CRI\_fixed\_PMI}$  using fixed precoder and power scaling factor according to the one configured CSI-RS resource
  - $SNR_{ue\_follow\_CRI\_fixed\_PMI}$  is specified based on CRS RE power
- b) Each candidate CRI value among 0, 1, ..., K-1 shall be reported at least  $\alpha\%$  of the time at  $SNR_{ue\_follow\_CRI\_fixed\_PMI}$  with multiple CSI-RS resources configured
- The number of configured CSI-RS resources K is specific to a test.

The accuracy of CRI reporting for Tests in Section 9.10.2 is determined by:

- a) The ratio of the throughput obtained when transmitting based on the reported CRI and fixed precoder with multiple CSI-RS resources configured compared to that obtained when transmitting based on the fixed precoder with one CSI-RS resource configured:  $\gamma = \frac{t_{ue\_follow\_CRI}}{t_{fixed\_TP1}}$
- $t_{ue\_follow\_CRI}$  is [70%] of the maximum throughput obtained at  $SNR_{ue\_follow\_CRI}$  using the CRI configured according to the CSI UE report
  - $t_{fixed\_TP1}$  is throughput obtained at  $SNR_{ue\_follow\_CRI}$  under assumption of single TP1 transmission
- b) CRI 2 value among 0, 1 and 2 shall be reported at least  $\alpha\%$  of the time at  $SNR_{ue\_follow\_CRI}$  with 2 CSI-RS resources configured
- c) CRI 0 value among 0, 1 and 2 shall be reported at least  $\beta\%$  of the time at  $SNR_{fixed\_TP1}$  with 2 CSI-RS resources configured
- $SNR_{fixed\_TP1}$  corresponds to [70%] of the maximum throughput under assumption of single TP1 transmission

## 9.10.1 Minimum requirement (PUSCH 3-1)

### 9.10.1.1 FDD

For the parameters specified in Table 9.10.1.1-1, and using the downlink physical channels specified in Annex C.3.2, the minimum requirements are specified in Table 9.10.1.1-2.

Table 9.10.1.1-1: CRI Test (FDD)

Parameter	Unit	Test 1-1 (K,N)=(2,8)	Test 1-2 (K,N)=(2,16)	Test 1-3 (K,N)=(4,32)	Test 1-4 (K,N)=(8,64)	
Bandwidth	MHz	10				
Transmission mode		9				
Propagation channel		EPA5				
Beamforming model		Annex B.4.6				
Precoding granularity	PRB	50				
Correlation and antenna configuration (Note 1)		4x2 XP High	8x2 XP High	8x2 XP High	8x2 XP High	
Cell-specific reference signals		Antenna ports 0,1				
eMIMO-Type		Class B				
Number of NZP-CSI resources (K) (Note 3)		2 for following CRI 1 for fixed CRI	2 for following CRI 1 for fixed CRI	4 for following CRI 1 for fixed CRI	8 for following CRI 1 for fixed CRI	
NZP-CSI-RS-ID-List		{0,1}	{0,1}	{0,1,2,3}	{0,1,2,3,4,5,6,7}	
legacyCSRLIST		{0,0}	{0,0}	{0,0,0,0}	{0,0,0,0,0,0,0,0}	
CSI reference signal configuration List		{0,1}	{0,1}	{0,1,2,3}	{0,1,2,3,0,1,2,3}	
Number of CSI-RS ports (N <sub>k</sub> )		{4,4}	{8,8}	{8,8,8,8}	{8,8,8,8,8,8,8,8}	
CSI-RS-SubframeConfig List		{1,1}	{1,1}	{1,1,1,1}	{1,1,1,1,2,2,2,2}	
CodeBookSubsetRestriction with ID=0		0x 0000 00000000 0001	0x 0000 0000 0000 0020 0000 0000 0001	0x 0000 0000 0000 0020 0000 0000 0001	0x 0000 0000 0000 0020 0000 0000 0001	
alternativeCodeBookEnabledFor4TX-r12		FALSE	N/A	N/A	N/A	
Downlink power allocation	$\rho_A$	dB	0	0	0	0
	$\rho_B$	dB	0	0	0	0
	$P_c$	dB	-3	-6	-6	-6
	$\sigma$	dB	-3	-3	-3	-3
$N_{oc}^{(j)}$	dB[mW/15kHz]	-98				
Reporting mode		PUSCH 3-1				
Reporting interval	ms	5				
CRI Delay	ms	8				
PMI delay	ms	8				
Measurement channel		R.50A-1 FDD	R.50A-2 FDD	R.50A-2 FDD	R.50A-3 FDD	
OCNG Pattern		OP.1 FDD				
Rank Number of PDSCH		1				
Scheduled PDSCH SFs		SF 0,2,3,4,7,8,9	SF 0,2,3,4,7,8,9	SF 0,2,3,4,7,8,9	SF 0,3,4,8,9	
Max number of HARQ transmissions		4				
Redundancy version coding sequence		{0,1,2,3}				
Note 1:	If the UE reports in an available uplink reporting instance at subframe SF#n based on CRI/PMI estimation at a downlink SF not later than SF#(n-4), this reported CRI/PMI cannot be applied at the eNB downlink before SF#(n+4).					
Note 2:	PDSCH_RA= 0 dB, PDSCH_RB= 0 dB in order to have the same PDSCH and OCNG power per subcarrier at the receiver.					
Note 3:	When one CSI-RS resource configured, the configurations according to NZP-CSI-RS-ID = 0 are configured.					



**Table 9.10.1.1-2: Minimum requirement (FDD)**

	Test 1-1	Test 1-2	Test 1-3	Test 1-4
$\gamma$	1.2	1.2	1.3	1.35
$\alpha$	40	40	20	10
UE Category	$\geq 2$	$\geq 2$	$\geq 2$	$\geq 2$
Note1:	According to UE capability configuration list for the maximum number of NZP CSI-RS resource Kmax and the maximum number of total NZP CSI-RS ports N in each K =2,..., Kmax: if UE supports the combination of (K,N) =(8,64), then test 1-4 is applicable ; else if UE supports the combination of (K,N) =(4,32), then test 1-3 is applicable; else if UE supports the combination of (K,N) =(2,16), then test 1-2 is applicable; otherwise test 1-1 is applicable.			

### 9.10.1.2 TDD

For the parameters specified in Table 9.10.1.2-1, and using the downlink physical channels specified in Annex C.3.2, the minimum requirements are specified in Table 9.10.1.2-2.

Table 9.10.1.2-1: CRI Test (TDD)

Parameter		Unit	Test 1-1 (K,N)=(2,8)	Test 1-2 (K,N)=(2,16)	Test 1-3 (K,N)=(4,32)	Test 1-4 (K,N)=(8,64)
Bandwidth		MHz	10			
Transmission mode			9			
Uplink downlink configuration			2			
Special subframe configuration			4			
Propagation channel			EPA5			
Beamforming model			Annex B.4.6			
Precoding granularity		PRB	50			
Correlation and antenna configuration (Note 1)			4x2 XP High	8x2 XP High	8x2 XP High	8x2 XP High
Cell-specific reference signals eMIMO-Type			Antenna ports 0,1 Class B			
Number of NZP-CSI resources (K) (Note 3)			2 for following CRI 1 for fixed CRI	2 for following CRI 1 for fixed CRI	4 for following CRI 1 for fixed CRI	8 for following CRI 1 for fixed CRI
NZP-CSI-RS-ID-List			{0,1}	{0,1}	{0,1,2,3}	{0,1,2,3,4,5,6,7}
legacyCSRList			{0,0}	{0,0}	{0,0,0,0}	{0,0,0,0,0,0,0,0}
CSI reference signal configuration List			{0,1}	{0,1}	{0,1,2,3}	{0,1,2,3,0,1,2,3}
Number of CSI-RS ports (Nk)			{4,4}	{8,8}	{8,8,8,8}	{8,8,8,8,8,8,8,8}
CSI-RS-SubframeConfig List			{9,9}	{9,9}	{9,9,9,9}	{8,8,8,8,9,9,9,9}
CodeBookSubsetRestriction with ID=0			0x 0000 00000000 0001	0x 0000 0000 0000 0020 0000 0000 0001	0x 0000 0000 0000 0020 0000 0000 0001	0x 0000 0000 0000 0020 0000 0000 0001
alternativeCodeBookEnabledFor4TX-r12			FALSE	N/A	N/A	N/A
Downlink power allocation	$\rho_A$	dB	0	0	0	0
	$\rho_B$	dB	0	0	0	0
	$\alpha$ Pc	dB	-3	-6	-6	-6
	$\sigma$	dB	-3	-3	-3	-3
$M_{oc}^{(j)}$		dB[mW/15kHz]	-98			
Reporting mode			PUSCH 3-1			
Reporting interval		ms	10			
CRI Delay		ms	12			
PMI delay		ms	12			
Measurement channel			R.44A-1 TDD	R.44A-2 TDD	R.44A-2 TDD	R.44A-3 TDD
OCNG Pattern			OP.1 TDD			
Rank Number of PDSCH			1			
Scheduled PDSCH SFs			SF 0,1,3,6,8,9	SF 0,1,3,6,8,9	SF 0,1,3,6,8,9	SF 0,1,6,8,9
Max number of HARQ transmissions			4			
Redundancy version coding sequence			{0,1,2,3}			
ACK/NACK feedback mode			Multiplexing			
Note 1: If the UE reports in an available uplink reporting instance at subframe SF#n based on PMI estimation at a downlink SF not later than SF#(n-4), this reported PMI cannot be applied at the eNB downlink before SF#(n+4).						
Note 2: PDSCH_RA= 0 dB, PDSCH_RB= 0 dB in order to have the same PDSCH and OCNG power per subcarrier at the receiver.						
Note 3: When one CSI-RS resource configured, the configurations according to NZP-CSI-RS-ID 0 are configured.						
Note 4: PDCCH DCI format 0 with a trigger for aperiodic CQI shall be transmitted in downlink SF#4 to allow aperiodic CRI/CQI/PMI/RI to be transmitted on uplink SF#2.						

**Table 9.10.1.2-2: Minimum requirement (TDD)**

	Test 1-1	Test 1-2	Test 1-3	Test 1-4
$\gamma$	1.2	1.2	1.3	1.35
$\alpha$	40	40	20	10
UE Category	$\geq 2$	$\geq 2$	$\geq 2$	$\geq 2$
Note1:	According to UE capability configuration list for the maximum number of NZP CSI-RS resource Kmax and the maximum number of total NZP CSI-RS ports N in each K =2,..., Kmax: if UE supports the combination of (K,N) =(8,64), then test 1-4 is applicable; else if UE supports the combination of (K,N) =(4,32), then test 1-3 is applicable; else if UE supports the combination of (K,N) =(2,16), then test 1-2 is applicable; otherwise test 1-1 is applicable.			

## 9.10.2 Minimum requirement (PUSCH 3-1, QCL Type C)

### 9.10.2.1 FDD

The requirements are specified in Table 9.10.2.1-4, with the additional parameters in Table 9.10.2.1-1, Table 9.10.2.1-2 and Table 9.10.2.1-3. In Table 9.10.2.1-1, transmission point 1 (TP 1) is the serving cell transmitting PDCCCH, synchronization signals, PBCH and can transmit PDSCH, and transmission point 2 (TP 2) has different Cell ID and can transmit PDSCH. The downlink physical channel setup for TP 1 is according to Table C.3.2 and for TP 2 according to Table C.3.2.

**Table 9.10.2.1-1: Test Parameters**

Parameter		Unit	Fixed TP1 case		Follow CRI case	
			TP 1	TP 2	TP 1	TP 2
Downlink power allocation	$\rho_A$	dB	0	0	0	0
	$\rho_B$	dB	0 (Note 1)	0	0 (Note 1)	0
	$\sigma$	dB	-3	-3	-3	-3
$E_s/N_{oc}$		dB	SNR1 (Note 2)	SNR2 = SNR1 - [9] dB	SNR1 (Note 2)	SNR2 = SNR1 - [9] dB
$N_{oc}$ at antenna port		dBm/15kHz	-98			
BW <sub>Channel</sub>		MHz	10			
Cyclic Prefix			Normal			
PDSCH transmission mode			10			
Number of allocated resource block			50			
Cell ID			0	126	0	126
Number of control OFDM symbols / PDSCH start			2	2	2	2
Cell-specific reference signals			Antenna ports 0,1			
eMIMO-Type			Class B			
CSI reference signals 0			Antenna ports {15,16}	N/A	Antenna ports {15,16}	NA
CSI-RS 0 periodicity and subframe offset $T_{CSI-RS} / \Delta_{CSI-RS}$		Subframes	5 / 2		5 / 2	
CSI reference signal 0 configuration			0		0	
CSI reference signals 1			N/A	Antenna ports {15,16}	Antenna ports {15,16}	
CSI-RS 1 periodicity and subframe offset $T_{CSI-RS} / \Delta_{CSI-RS}$		Subframes		5 / 2	N/A	5 / 2
CSI reference signal 1 configuration				8		8
CodeBookSubsetRestriction for CSI-RS 0			001111	N/A	001111	N/A
CodeBookSubsetRestriction for CSI-RS 1			N/A	001111	N/A	001111
Zero-power CSI-RS 0 configuration $I_{CSI-RS} / \text{ZeroPower CSI-RS bitmap}$		Subframes/bitmap	2/ 001000000000 0000	N/A	2/ 001000000000 0000	N/A
Zero-power CSI-RS1 configuration $I_{CSI-RS} / \text{ZeroPower CSI-RS bitmap}$		Subframes/bitmap	N/A	2/ 001000000000 0000	N/A	2/ 001000000000 0000
Timing offset relative to TP 1		us	N/A	0	N/A	0
Frequency offset relative to TP 1		Hz	N/A	0	N/A	0
qcl-Operation, 'PDSCH RE Mapping and Quasi-Co-Location Indicator'			Type B, '00' Table 9.10.2.1-2		Type C, PQI based on UE reporting Table 9.10.2.1-3	
Reporting mode			PUSCH 3-1			
Reporting interval		ms	5			
CRI Delay		ms	8			
PMI delay		ms	8			
Measurement channel			R.97 FDD			
Correlation and antenna configuration			2x2 Low			

Propagation channel		EPA5
Note 1: $P_B = 1$ Note 2: TP1 SNR based on SNR value derived for exact test metric verification and can be equal to $SNR_{ue\_follow\_CRI}$ or $SNR_{fixed\_TP1}$		

**Table 9.10.2.1-2: Configurations of PQI and DL transmission hypothesis for each PQI set (Fixed TP1 case)**

PQI set index	Parameters in each PQI set		DL transmission hypothesis for each PQI Set	
	NZP CSI-RS Index (For quasi co-location)	ZP CSI-RS configuration	TP 1	TP 2
PQI set 0	CSI-RS 0	ZP CSI-RS 0	PDSCH	Blank

**Table 9.10.2.1-3: Configurations of PQI and DL transmission hypothesis for each PQI set (Follow CRI case)**

PQI set index	Parameters in each PQI set		DL transmission hypothesis for each PQI Set	
	NZP CSI-RS Index (For quasi co-location)	ZP CSI-RS configuration	TP 1	TP 2
PQI set 0	CSI-RS 0	ZP CSI-RS 0	PDSCH	Blank
PQI set 1	CSI-RS 1	ZP CSI-RS 1	Blank	PDSCH
PQI set 2	CSI-RS 0 for CW1 CSI-RS 1 for CW2	ZP CSI-RS 0	PDSCH	PDSCH

**Table 9.10.2.1-4: Minimum requirement (FDD)**

	Test 1
$\gamma$	1.2
$\alpha$	40
$\beta$	60
UE Category	$\geq 2$

## 9.10.2.2 TDD

The requirements are specified in Table 9.10.2.2-4, with the additional parameters in Table 9.10.2.2-1, Table 9.10.2.2-2 and Table 9.10.2.2-3. In Table 9.10.2.2-1, transmission point 1 (TP 1) is the serving cell transmitting PDCCCH, synchronization signals, PBCH and can transmit PDSCH, and transmission point 2 (TP 2) has different Cell ID and can transmit PDSCH. The downlink physical channel setup for TP 1 is according to Table C.3.2 and for TP 2 according to Table C.3.2.

**Table 9.10.2.2-1: Test Parameters**

Parameter		Unit	Fixed TP1 case		Follow CRI case	
			TP 1	TP 2	TP 1	TP 2
Downlink power allocation	$\rho_A$	dB	0	0	0	0
	$\rho_B$	dB	0 (Note 1)	0	0 (Note 1)	0
	$\sigma$	dB	-3	-3	-3	-3
$E_s/N_{oc}$		dB	SNR1 (Note 2)	SNR2 = SNR1 - [9] dB	SNR1 (Note 2)	SNR2 = SNR1 - [9] dB
$N_{oc}$ at antenna port		dBm/15kHz	-98			
Uplink downlink configuration			1			
Special subframe configuration			4			
BW <sub>Channel</sub>		MHz	10			
Cyclic Prefix			Normal			
PDSCH transmission mode			10			
Number of allocated resource block			50			
Cell ID			0	126	0	126
Number of control OFDM symbols / PDSCH start			2	2	2	2
Cell-specific reference signals			Antenna ports 0,1			
eMIMO-Type			Class B			
CSI reference signals 0			Antenna ports {15,16}	N/A	Antenna ports {15,16}	NA
CSI-RS 0 periodicity and subframe offset $T_{CSI-RS} / \Delta_{CSI-RS}$		Subframes	5 / 4		5 / 4	
CSI reference signal 0 configuration			0		0	
CSI reference signals 1			Antenna ports {15,16}	N/A	Antenna ports {15,16}	
CSI-RS 1 periodicity and subframe offset $T_{CSI-RS} / \Delta_{CSI-RS}$		Subframes	5 / 4		5 / 4	
CSI reference signal 1 configuration			8		8	
CodeBookSubsetRestriction for CSI-RS 0			001111	N/A	001111	N/A
CodeBookSubsetRestriction for CSI-RS 1			N/A	001111	N/A	001111
Zero-power CSI-RS 0 configuration $I_{CSI-RS} / \text{ZeroPower CSI-RS bitmap}$		Subframes/bitmap	4/ 001000000000 0000	N/A	4/ 001000000000 0000	N/A
Zero-power CSI-RS1 configuration $I_{CSI-RS} / \text{ZeroPower CSI-RS bitmap}$		Subframes/bitmap	N/A	4/ 001000000000 0000	N/A	4/ 001000000000 0000
Timing offset relative to TP <sub>1</sub>		us	N/A	0	N/A	0
Frequency offset relative to TP <sub>1</sub>		Hz	N/A	0	N/A	0
<i>qcl-Operation</i> , 'PDSCH RE Mapping and Quasi-Co-Location Indicator'			Type B, '00' Table 9.10.2.2-2		Type C, PQI based on UE reporting Table 9.10.2.2-3	
Reporting mode			PUSCH 3-1			



Reporting interval	ms	5
CRI Delay	ms	8
PMI delay	ms	8
Measurement channel		R.97 TDD
Correlation and antenna configuration		2x2 Low
Propagation channel		EPA5
Note 1: $P_B = 1$		
Note 2: TP1 SNR based on SNR value derived for exact test metric verification and can be equal to $SNR_{ue\_follow\_CRI}$ or $SNR_{fixed\_TP1}$		

**Table 9.10.2.2-2: Configurations of PQI and DL transmission hypothesis for each PQI set (Fixed TP1 case)**

PQI set index	Parameters in each PQI set		DL transmission hypothesis for each PQI Set	
	NZP CSI-RS Index (For quasi co-location)	ZP CSI-RS configuration	TP 1	TP 2
PQI set 0	CSI-RS 0	ZP CSI-RS 0	PDSCH	Blank

**Table 9.10.2.2-3: Configurations of PQI and DL transmission hypothesis for each PQI set (Follow CRI case)**

PQI set index	Parameters in each PQI set		DL transmission hypothesis for each PQI Set	
	NZP CSI-RS Index (For quasi co-location)	ZP CSI-RS configuration	TP 1	TP 2
PQI set 0	CSI-RS 0	ZP CSI-RS 0	PDSCH	Blank
PQI set 1	CSI-RS 1	ZP CSI-RS 1	Blank	PDSCH
PQI set 2	CSI-RS 0 for CW1 CSI-RS 1 for CW2	ZP CSI-RS 0	PDSCH	PDSCH

**Table 9.10.2.2-4: Minimum requirement (FDD)**

	Test 1
$\gamma$	1.2
$\alpha$	40
$\beta$	60
UE Category	$\geq 2$

## 9.11 Reporting of Hybrid Channel state information

### 9.11.1 Minimum requirement (with eMIMO-Type configured as Class B with more than one CSI-RS resource configured and eMIMO-Type2 as Class B with one CSI-RS resource configured)

The purpose of this test is to verify that the reported CRI<sup>(1)</sup> from eMIMO-Type and PMI<sup>(2)</sup> from eMIMO-Type2 are accurate.

The accuracy of CRI and PMI reporting are determined by the ratio of the throughput obtained when transmitting based on UE reported CRI<sup>(1)</sup> and PMI<sup>(2)</sup> compared to that obtained when transmitting based on the random precoding and fixed CRI:

$$\gamma = \frac{t_{ue, followCRI^{(1)}, followPMI^{(2)}}}{t_{fixedCRI^{(1)}, rndPMI^{(2)}}}$$

- $t_{ue, followCRI^{(1)}, followPMI^{(2)}}$  is [70%] of the maximum throughput obtained at  $SNR_{ue, followCRI^{(1)}, followPMI^{(2)}}$  using following precoder according to UE reported PMI<sup>(2)</sup> for eMIMO-Type2 and power scaling factor according to UE reported CRI<sup>(1)</sup> for eMIMO-Type
- $t_{fixedCRI^{(1)}, rndPMI^{(2)}}$  is throughput obtained at  $SNR_{ue, followCRI^{(1)}, followPMI^{(2)}}$  using random precoder and power scaling factor according to the one configured CSI-RS resource
- $SNR_{ue, followCRI^{(1)}, followPMI^{(2)}}$  is specified based on CRS RE power

#### 9.11.1.1 FDD

For the parameters specified in Table 9.11.1.1-1, and using the downlink physical channels specified in Annex C.3.2, the minimum requirements are specified in Table 9.11.1.1-2.

Table 9.11.1.1-1: CRI/PMI test for single layer (FDD)

Parameter	Unit	Test 1	
Bandwidth	MHz	10	
Transmission mode		9	
Propagation channel		EPA5	
Precoding granularity (only for reporting and following PMI)	PRB	50	
Correlation and antenna configuration		4*2 ULA Low	
Cell-specific reference signals		Antenna ports 0,1	
Beamforming model		B.4.6 (Note 4)	
CSI reference signal configuration List		{0,1}	
Number of CSI-RS ports (Nk)		{4,4}	
CSI-RS-SubframeConfig List		{1,1}	
eMIMO-Type		Class B	
Number of NZP-CSI resources (K)		2 for following CRI	
NZP-CSI-RS-ID-List		{0,1}	
eMIMO-Type2		Class B	
NZP-CSI-RS-ID		{0}	
alternativeCodebookEnabledCL ASSB_K1		FALSE	
codebookSubsetRestriction		001111	
Reporting mode		PUSCH 3-1	
Physical channel for CRI <sup>(1)</sup> reporting		PUSCH	
Reporting interval for CRI <sup>(1)</sup> reporting	ms	40 (Note 5)	
Physical channel for RI <sup>(2)</sup> /CQI <sup>(2)</sup> /PMI <sup>(2)</sup> reporting		PUSCH	
Reporting Interval for RI <sup>(2)</sup> /CQI <sup>(2)</sup> /PMI <sup>(2)</sup> reporting	ms	5	
Downlink power allocation	$\rho_A$	dB	0
	$\rho_B$	dB	0
	$P_c$	dB	-3
	$\sigma$	dB	-3
Rank Number of PDSCH		1	
Measurement channel		R.50A-1 FDD	
OCNG Pattern		OP.1 FDD	
Max number of HARQ transmissions		4	
Redundancy version coding sequence		{0,1,2,3}	
Scheduled PDSCH SFs		SF 0,2,3,4,7,8,9	
Note 1:	For random precoder selection, the precoder shall be updated in each TTI (1 ms granularity).		
Note 2:	If the UE reports in an available uplink reporting instance at subframe SF#n based on CRI,PMI estimation at a downlink SF not later than SF#(n-4), this reported CRI, PMI cannot be applied at the eNB downlink before SF#(n+4).		
Note 3:	To avoid collisions between CQI/PMI reports and HARQ-ACK it is necessary to report both on PUSCH instead of PUCCH.		
Note 4:	The precoder matrix as specified in Table 6.3.4.2.3-1 of [4]. For following PMI, PMI equals to UE reported PMI <sup>(2)</sup> for eMIMO-Type2 "Class B".		
Note 5:	PDCCH DCI format 0 with a trigger for aperiodic CSI of eMIMO-Type shall be transmitted in downlink SF#1 to allow aperiodic CRI <sup>(1)</sup> to be transmitted on uplink SF#5. PDCCH DCI format 0 with a trigger for aperiodic CSI of eMIMO-Type2 shall be transmitted in downlink SF#1,6 to allow aperiodic RI <sup>(2)</sup> /CQI <sup>(2)</sup> /PMI <sup>(2)</sup> to be transmitted on uplink SF#5,0.		

**Table 9.11.1.1-2: Minimum requirement (FDD)**

Parameter	Test 1
$\gamma$	[1.3]
UE Category	$\geq 2$

### 9.11.1.2 TDD

For the parameters specified in Table 9.11.1.2-1, and using the downlink physical channels specified in Annex C.3.2, the minimum requirements are specified in Table 9.11.1.2-2.

Table 9.11.1.2-1: CRI/PMI test for single layer (TDD)

Parameter	Unit	Test 1	
Bandwidth	MHz	10	
Transmission mode		9	
Uplink downlink configuration		2	
Special subframe configuration		4	
Propagation channel		EPA5	
Precoding granularity (only for reporting and following PMI)	PRB	50	
Correlation and antenna configuration		4*2 ULA Low	
Cell-specific reference signals		Antenna ports 0,1	
Beamforming model		B.4.6 (Note 4)	
CSI reference signal configuration List		{0,1}	
Number of CSI-RS ports (Nk)		{4,4}	
CSI-RS-SubframeConfig List		{9,9}	
eMIMO-Type		Class B	
Number of NZP-CSI resources (K)		2 for following CRI	
NZP-CSI-RS-ID-List		{0,1}	
eMIMO-Type2		Class B	
NZP-CSI-RS-ID		{0}	
alternativeCodebookEnabledCL		FALSE	
codebookSubsetRestriction		001111	
Reporting mode		PUSCH 3-1	
Physical channel for CRI <sup>(1)</sup> reporting		PUSCH	
Reporting interval for CRI <sup>(1)</sup> reporting	ms	40 (Note 5)	
Physical channel for RI <sup>(2)</sup> /CQI <sup>(2)</sup> /PMI <sup>(2)</sup> reporting		PUSCH	
Reporting Interval for RI <sup>(2)</sup> /CQI <sup>(2)</sup> /PMI <sup>(2)</sup> reporting	ms	10	
Downlink power allocation	$\rho_A$	dB	0
	$\rho_B$	dB	0
	$\rho_C$	dB	-3
	$\sigma$	dB	-3
Rank Number of PDSCH		1	
Measurement channel		R.44A-1 TDD	
OCNG Pattern		OP.1 TDD	
Max number of HARQ transmissions		4	
Redundancy version coding sequence		{0,1,2,3}	
Scheduled PDSCH SFs		SF 0,1,3,6,8,9	
Note 1: For random precoder selection, the precoder shall be updated in each TTI (1 ms granularity).			
Note 2: If the UE reports in an available uplink reporting instance at subframe SF#n based on CRI,PMI estimation at a downlink SF not later than SF#(n-4), this reported CRI, PMI cannot be applied at the eNB downlink before SF#(n+4).			
Note 3: To avoid collisions between CQI/PMI reports and HARQ-ACK it is necessary to report both on PUSCH instead of PUCCH.			
Note 4: The precoder matrix as specified in Table 6.3.4.2.3-1of [4].For following PMI, PMI equals to UE reported PMI <sup>(2)</sup> for eMIMO-Type2 "Class B".			
Note 5: PDCCH DCI format 0 with a trigger for aperiodic CSI of eMIMO-Type shall be transmitted in downlink SF#4 to allow aperiodic CRI <sup>(1)</sup> to be transmitted on uplink SF#4. PDCCH DCI format 0 with a trigger for aperiodic CSI of eMIMO-Type2 shall be transmitted in downlink SF#4 to allow aperiodic RI <sup>(2)</sup> /CQI <sup>(2)</sup> /PMI <sup>(2)</sup> to be transmitted on uplink SF#2.			

**Table 9.11.2.2-2: Minimum requirement (TDD)**

Parameter	Test 1
$\gamma$	[1.3]
UE Category	$\geq 2$

## 9.12 CSI reporting (UE supporting Short TTI)

The requirements in this sub-clause are valid for UEs capable of short TTI.

### 9.12.1 CQI reporting under fading conditions (Cell-Specific Reference Symbol)

The reporting accuracy of the channel quality indicator (CQI) under frequency non-selective fading conditions is determined by the reporting variance, and the relative increase of the throughput obtained when the transport format transmitted is that indicated by the reported CQI compared to the case for which a fixed transport format configured according to the reported median CQI is transmitted. In addition, the reporting accuracy is determined by a minimum BLER using the transport formats indicated by the reported CQI. The purpose is to verify that the UE is tracking the channel variations and selecting the largest transport format possible according to the prevailing channel state for frequently non-selective scheduling. To account for sensitivity of the input SNR the CQI reporting under frequency non-selective fading conditions is considered to be verified if the reporting accuracy is met for at least one of two SNR levels separated by an offset of 1 dB.

#### 9.12.1.1 FDD

For the parameters specified in Table 9.12.1.1-1, Table 9.12.1.1-2 and Table 9.12.1.1-3 using the downlink physical channels specified in Annex C.3.2, the minimum requirements are specified in Table 9.12.1.1-4 by the following

- a) a CQI index not in the set {median CQI -1, median CQI, median CQI +1} shall be reported at least  $\alpha\%$  of the time;
- b) the ratio of the throughput obtained when transmitting the transport format indicated by each reported wideband CQI index and that obtained when transmitting a fixed transport format configured according to the wideband CQI median shall be  $\geq \gamma$ ;
- c) when transmitting the transport format indicated by each reported wideband CQI index, the average BLER for the indicated transport formats shall be greater or equal to 0.02.

Table 9.12.1.1-1: Fading test for slot-PDSCH (FDD)

Parameter	Unit	Test 1		Test 2	
Bandwidth	MHz	10 MHz			
Transmission mode		4 (ports 0 and 1)			
Downlink power allocation	$\rho_A$	-3			
	$\rho_B$	-3			
	$\sigma$	0			
SNR (Note 3)	dB	1	2	9	10
$\hat{I}_{or}^{(j)}$	dB[mW/15kHz]	-97	-96	-89	-88
$N_{oc}^{(j)}$	dB[mW/15kHz]	-98		-98	
Propagation channel		EPA5			
Correlation and antenna configuration		High (2 x 2)			
Reporting mode		PUSCH 1-1			
Reporting interval	ms	5			
CQI delay	slots	8			
Max number of HARQ transmissions		1			
CodeBookSubsetRestriction bitmap		00 0001			
DL TTI length		Slot			
Configured SPDCCH-PRB sets		{Set 1}			
SPDCCH-PRB set used for DCI transmission		Set 1			
Note 1:	If the UE reports in an available uplink reporting instance at slot #n based on CQI estimation at a downlink slot not later than slot #(n-4), this reported wideband CQI cannot be applied at the eNB downlink before slot #(n+4).				
Note 2:	Reference measurement channel RC.26 FDD according to Table A.4-1 for Categories 2 or higher with one sided dynamic OCNG Pattern OP.1 FDD as described in Annex A.5.1.1.				
Note 3:	For each test, the minimum requirements shall be fulfilled for at least one of the two SNR(s) and the respective wanted signal input level.				

Table 9.12.1.1-2: Fading test for subslot-PDSCH (FDD)

Parameter	Unit	Test 3		Test 4	
Bandwidth	MHz	10 MHz			
Transmission mode		4 (ports 0 and 1)			
Downlink power allocation	$\rho_A$	-3			
	$\rho_B$	-3			
	$\sigma$	0			
SNR (Note 3)	dB	1	2	9	10
$\hat{I}_{or}^{(j)}$	dB[mW/15kHz]	-97	-96	-89	-88
$N_{oc}^{(j)}$	dB[mW/15kHz]	-98		-98	
Propagation channel		EPA5			
Correlation and antenna configuration		High (2 x 2)			
Reporting mode		PUSCH 1-1			
Reporting interval	ms	5			
CQI delay	subslots	8 or 12 (Note 1)			
Max number of HARQ transmissions		1			
CodeBookSubsetRestriction bitmap		00 0001			
DL TTI length		Subslot			
Configured SPDCCH-PRB sets		{Set 1}			
SPDCCH-PRB set used for DCI transmission		Set 1			
Note 1:	If the UE reports in an available uplink reporting instance at subslot #n based on CQI estimation at a downlink slot not later than subslot #(n-k), this reported wideband CQI cannot be applied at the eNB downlink before subslot #(n+k), where k = 4 for UE capability <i>ProcessingTimelineSet=set1</i> and k=6 for UE capability <i>ProcessingTimelineSet=set2</i> .				
Note 2:	Reference measurement channel RC.28 FDD according to Table A.4-1 for Categories 2 or higher with one sided dynamic OCNB Pattern OP.1 FDD as described in Annex A.5.1.1.				
Note 3:	For each test, the minimum requirements shall be fulfilled for at least one of the two SNR(s) and the respective wanted signal input level.				

Table 9.12.1.1-3: SPDCCH parameters (FDD)

Parameter	Unit	Set 1
Reference symbol		CRS
Number of PRB per SPDCCH-PRB set		16
Transmission type		Localized
Number of OFDM symbols		1
Number of PRBs per SPDCCH-PRB set (Note 1)		16
Rate Matching mode		Mode 1
SPDCCH L1 Reuse Indication		Not configured
Aggregation level	SCCE	4
Note 1:	PRB = {0, 1, ..., 15}.	

Table 9.12.1.1-4: Minimum requirement for slot/subslot-PDSCH (FDD)

	Test 1	Test 2	Test 3	Test 4
$\alpha$ [%]	20	20	20	20
$\gamma$	1.05	1.05	1.05	1.05
UE Category	$\geq 2$	$\geq 2$	$\geq 2$	$\geq 2$



## 9.12.1.2 TDD

For the parameters specified in Table 9.12.1.2-1 and Table 9.12.1.2-2 using the downlink physical channels specified in Annex C.3.2, the minimum requirements are specified in Table 9.12.1.2-3 by the following

- a CQI index not in the set {median CQI -1, median CQI, median CQI +1} shall be reported at least  $\alpha\%$  of the time;
- the ratio of the throughput obtained when transmitting the transport format indicated by each reported wideband CQI index and that obtained when transmitting a fixed transport format configured according to the wideband CQI median shall be  $\geq \gamma$ ;
- when transmitting the transport format indicated by each reported wideband CQI index, the average BLER for the indicated transport formats shall be greater or equal to 0.02.

Table 9.12.1.2-1: Fading test for slot-PDSCH (TDD)

Parameter		Unit	Test 1		Test 2	
Bandwidth		MHz	10 MHz			
Transmission mode			4 (ports 0 and 1)			
Uplink downlink configuration			2			
Special subframe configuration			4			
Downlink power allocation	$\rho_A$	dB	-3			
	$\rho_B$	dB	-3			
	$\sigma$	dB	0			
SNR (Note 3)		dB	1	2	9	10
$\hat{I}_{or}^{(j)}$		dB[mW/15kHz]	-97	-96	-89	-88
$N_{oc}^{(j)}$		dB[mW/15kHz]	-98		-98	
Propagation channel			EPA5			
Correlation and antenna configuration			High (2 x 2)			
Reporting mode			PUSCH 1-1			
Reporting interval		ms	5			
CQI delay		slots	8			
Max number of HARQ transmissions			1			
CodeBookSubsetRestriction bitmap			00 0001			
DL TTI length			Slot			
Configured SPDCCH-PRB sets			{Set 1}			
SPDCCH-PRB set used for DCI transmission			Set 1			
ACK/NACK feedback mode			Multiplexing			
<p>Note 1: If the UE reports in an available uplink reporting instance at slot #n based on CQI estimation at a downlink slot not later than slot #(n-4), this reported wideband CQI cannot be applied at the eNB downlink before slot #(n+4).</p> <p>Note 2: Reference measurement channel RC.26 TDD according to Table A.4-1 for Categories 2 or higher with one sided dynamic OCNG Pattern OP.1 TDD as described in Annex A.5.1.1.</p> <p>Note 3: For each test, the minimum requirements shall be fulfilled for at least one of the two SNR(s) and the respective wanted signal input level.</p>						

**Table 9.12.1.2-2: SPDCCH parameters (FDD)**

Parameter	Unit	Set 1
Reference symbol		CRS
Number of PRB per SPDCCH-PRB set		16
Transmission type		Localized
Number of OFDM symbols		1
Number of PRBs per SPDCCH-PRB set (Note 1)		16
Rate Matching mode		Mode 1
SPDCCH L1 Reuse Indication		Not configured
Aggregatoin level	SCCE	4

Note 1: PRB = {0, 1, ..., 15}.

**Table 9.12.1.2-3: Minimum requirement for slot-PDSCH (FDD)**

	Test 1	Test 2
$\alpha$ [%]	20	20
$\gamma$	1.05	1.05
UE Category	$\geq 2$	$\geq 2$

## 9.12.2 CQI reporting under fading conditions (CSI Reference Symbol)

### 9.12.2.1 FDD

For the parameters specified in Table 9.12.2.1-1, Table 9.12.2.1-2, and Table 9.12.2.1-3 using the downlink physical channels specified in Annex C.3.2, the minimum requirements are specified in Table 9.12.2.1-4 by the following

- a CQI index not in the set {median CQI -1, median CQI, median CQI +1} shall be reported at least  $\alpha\%$  of the time;
- the ratio of the throughput obtained when transmitting the transport format indicated by each reported wideband CQI index and that obtained when transmitting a fixed transport format configured according to the wideband CQI median shall be  $\geq \gamma$ ;
- when transmitting the transport format indicated by each reported wideband CQI index, the average BLER for the indicated transport formats shall be greater or equal to [0.02].

Table 9.12.2.1-1: Fading test for slot-PDSCH (FDD)

Parameter	Unit	Test 1		Test 2	
Bandwidth	MHz	10 MHz			
Transmission mode		9			
Downlink power allocation	$\rho_A$	dB			
	$\rho_B$	dB			
	$\sigma$	dB			
SNR (Note 3)	dB	3	4	12	13
$\hat{I}_{or}^{(j)}$	dB[mW/15kHz]	-95	-94	-86	-85
$N_{oc}^{(j)}$	dB[mW/15kHz]	-98		-98	
Propagation channel		EPA5			
Correlation and antenna configuration		High (2 x 2)			
Beamforming Model		As specified in Section B.4.3			
Cell-specific reference signals		Antenna ports 0,1			
CSI reference signals		Antenna ports 15,16			
CSI-RS periodicity and subframe offset $T_{CSI-RS} / \Delta_{CSI-RS}$		5/1			
CSI-RS reference signal configuration		0			
Reporting mode		PUSCH 1-1			
Reporting interval	ms	5			
CQI delay	slots	8			
Max number of HARQ transmissions		1			
CodeBookSubsetRestriction bitmap		00 0001			
DL TTI length		Slot			
Configured SPDCCH-PRB sets		{Set 1}			
SPDCCH-PRB set used for DCI transmission		Set 1			
Note 1:	For slot-PDSCH, if the UE reports in an available uplink reporting instance at slot #n based on CQI estimation at a downlink slot not later than slot #(n-4), this reported wideband CQI cannot be applied at the eNB downlink before slot #(n+4).				
Note 2:	Reference measurement channel RC.27 FDD according to Table A.4-1 for Categories 2 or higher with one sided dynamic OCNG Pattern OP.1 FDD as described in Annex A.5.1.1.				
Note 3:	For each test, the minimum requirements shall be fulfilled for at least one of the two SNR(s) and the respective wanted signal input level.				

Table 9.12.2.1-2: Fading test for subslot-PDSCH (FDD)

Parameter	Unit	Test 3		Test 4	
Bandwidth	MHz	10 MHz			
Transmission mode		9			
Downlink power allocation	$\rho_A$	dB			
	$\rho_B$	dB			
	$\sigma$	dB			
SNR (Note 3)	dB	4	5	12	13
$\hat{I}_{or}^{(j)}$	dB[mW/15kHz]	-94	-93	-86	-85
$N_{oc}^{(j)}$	dB[mW/15kHz]	-98		-98	
Propagation channel		EPA5			
Correlation and antenna configuration		High (2 x 2)			
Beamforming Model		As specified in Section B.4.3			
Cell-specific reference signals		Antenna ports 0,1			
CSI reference signals		Antenna ports 15,16			
CSI-RS periodicity and subframe offset $T_{CSI-RS} / \Delta_{CSI-RS}$		5/1			
CSI-RS reference signal configuration		0			
Reporting mode		PUSCH 1-1			
Reporting interval	ms	5			
CQI delay	subslots	8 or 12 (Note 1)			
Max number of HARQ transmissions		1			
CodeBookSubsetRestriction bitmap		00 0001			
DL TTI length		Subslot			
Configured SPDCCH-PRB sets		{Set 1}			
SPDCCH-PRB set used for DCI transmission		Set 1			
<p>Note 1: If the UE reports in an available uplink reporting instance at subslot #n based on CQI estimation at a downlink slot not later than subslot #(n-k), this reported wideband CQI cannot be applied at the eNB downlink before subslot #(n+k), where k = 4 for UE capability <i>ProcessingTimelineSet=set1</i> and k=6 for UE capability <i>ProcessingTimelineSet=set2</i>.</p> <p>Note 2: Reference measurement channel RC.29 FDD according to Table A.4-1 for Categories 2 or higher with one sided dynamic OCNG Pattern OP.1 FDD as described in Annex A.5.1.1.</p> <p>Note 3: For each test, the minimum requirements shall be fulfilled for at least one of the two SNR(s) and the respective wanted signal input level.</p>					

**Table 9.12.2.1-3: SPDCCH parameters (FDD)**

Parameter	Unit	Set 1
Reference symbol		CRS
Number of PRB per SPDCCH-PRB set		16
Transmission type		Localized
Number of OFDM symbols		2
Number of PRBs per SPDCCH-PRB set (Note 1)		16
Rate Matching mode		Mode 1
SPDCCH L1 Reuse Indication		Not configured
Aggregatoin level	SCCE	8

Note 1: PRB = {0, 1, ..., 15}.

**Table 9.12.2.1-4: Minimum requirement for slot/subslot-PDSCH (FDD)**

	Test 1	Test 2	Test 3	Test 4
$\alpha$ [%]	20	20	20	20
$\gamma$	1.05	1.05	1.05	1.05
UE Category	$\geq 2$	$\geq 2$	$\geq 2$	$\geq 2$

### 9.12.2.2 TDD

For the parameters specified in Table 9.12.2.2-1 and Table 9.12.2.2-2 using the downlink physical channels specified in Annex C.3.2, the minimum requirements are specified in Table 9.12.2.2-3 by the following

- a) a CQI index not in the set {median CQI -1, median CQI, median CQI +1} shall be reported at least  $\alpha\%$  of the time;
- b) the ratio of the throughput obtained when transmitting the transport format indicated by each reported wideband CQI index and that obtained when transmitting a fixed transport format configured according to the wideband CQI median shall be  $\geq \gamma$ ;
- c) when transmitting the transport format indicated by each reported wideband CQI index, the average BLER for the indicated transport formats shall be greater or equal to [0.02].

Table 9.12.2.2-1: Fading test for slot-PDSCH (TDD)

Parameter		Unit	Test 1		Test 2	
Bandwidth		MHz	10 MHz			
Transmission mode			9			
Uplink downlink configuration			2			
Special subframe configuration			4			
Downlink power allocation	$\rho_A$	dB	0			
	$\rho_B$	dB	0			
	$\sigma$	dB	-3			
SNR (Note 3)		dB	3	4	12	13
$\hat{I}_{or}^{(j)}$		dB[mW/15kHz]	-95	-94	-86	-85
$N_{oc}^{(j)}$		dB[mW/15kHz]	-98		-98	
Propagation channel			EPA5			
Correlation and antenna configuration			High (2 x 2)			
Beamforming Model			As specified in Section B.4.3			
Cell-specific reference signals			Antenna ports 0,1			
CSI reference signals			Antenna ports 15,16			
CSI-RS periodicity and subframe offset $T_{CSI-RS} / \Delta_{CSI-RS}$			5/1			
CSI-RS reference signal configuration			0			
Reporting mode			PUSCH 1-1			
Reporting interval		ms	5			
CQI delay		Slots	8			
Max number of HARQ transmissions			1			
CodeBookSubsetRestriction bitmap			00 0001			
DL TTI length			Slot			
Configured SPDCCH-PRB sets			{Set 1}			
SPDCCH-PRB set used for DCI transmission			Set 1			
ACK/NACK feedback mode			Multiplexing			
<p>Note 1: If the UE reports in an available uplink reporting instance at slot #n based on CQI estimation at a downlink slot not later than slot #(n-4), this reported wideband CQI cannot be applied at the eNB downlink before slot #(n+4).</p> <p>Note 2: Reference measurement channel RC.27 TDD according to Table A.4-1 for Categories 2 or higher with one sided dynamic OCNB Pattern OP.1 TDD as described in Annex A.5.1.1.</p> <p>Note 3: For each test, the minimum requirements shall be fulfilled for at least one of the two SNR(s) and the respective wanted signal input level.</p>						

Table 9.12.2.2-2: SPDCCH parameters (TDD)

Parameter	Unit	Set 1
Reference symbol		CRS
Number of PRB per SPDCCH-PRB set		16
Transmission type		Localized
Number of OFDM symbols		2
Number of PRBs per SPDCCH-PRB set (Note 1)		16
Rate Matching mode		Mode 1
SPDCCH L1 Reuse Indication		Not configured
Aggregation level	SCCE	8

Note 1: PRB = {0, 1, ..., 15}.

Table 9.12.2.2-3: Minimum requirement for slot-PDSCH (TDD)

	Test 1	Test 2
$\alpha$ [%]	20	20
$\gamma$	1.05	1.05
UE Category	$\geq 2$	$\geq 2$

## 9.13 CSI reporting for 8Rx UE

### 9.13.1 CQI reporting definition under AWGN conditions

The reporting accuracy of the channel quality indicator (CQI) under frequency non-selective conditions is determined by the reporting variance and the BLER performance using the transport format indicated by the reported CQI median. The purpose is to verify that the reported CQI values are in accordance with the CQI definition given in TS 36.213 [6]. To account for sensitivity of the input SNR the reporting definition is considered to be verified if the reporting accuracy is met for at least one of two SNR levels separated by an offset of 1 dB.

#### 9.13.1.1 Minimum requirement PUCCH 1-1 with Rank 4 (CSI Reference Symbols)

The minimum requirements for dual codeword transmission are defined in terms of a reporting spread of the wideband CQI value for codeword #1, and their BLER performance using the transport format indicated by the reported CQI median of codeword #0 and codeword #1. The precoding used at the transmitter is a fixed precoding matrix specified by the bitmap parameter *codebookSubsetRestriction*. The propagation condition assumed for the minimum performance requirement is defined in subclause B.1.

##### 9.13.1.2.1 Void

##### 9.13.1.2.2 TDD

The following requirements apply to UE Category 8 and DL Category 14, 17~20,  $\geq 22$ . For the parameters specified in table 9.13.1.2.2-1, and using the downlink physical channels specified in tables C.3.2-1 and C.3.2-2, the reported offset level of the wideband spatial differential CQI for codeword #1 (Table 7.2-2 in TS 36.213 [6]) shall be used to determine the wideband CQI index for codeword #1 as

$$\text{wideband CQI}_1 = \text{wideband CQI}_0 - \text{Codeword 1 offset level}$$

The wideband CQI<sub>1</sub> shall be within the set {median CQI<sub>1</sub> - 1, median CQI<sub>1</sub>, median CQI<sub>1</sub> + 1} for more than 90% of the time, where the resulting wideband values CQI<sub>1</sub> shall be used to determine the median CQI values for codeword #1. For both codewords #0 and #1, the PDSCH BLER using the transport format indicated by the respective median CQI<sub>0</sub> - 1 and median CQI<sub>1</sub> - 1 shall be less than or equal to 0.1. Furthermore, for both codewords #0 and #1, the PDSCH BLER using the transport format indicated by the respective median CQI<sub>0</sub> + 1 and median CQI<sub>1</sub> + 1 shall be greater than or equal to 0.1.

Table 9.13.1.2.2-1: PUCCH 1-1 static test 4x8 (TDD)

Parameter	Unit	Test 1		Test 2	
Bandwidth	MHz			10	
PDSCH transmission mode				9	
Uplink downlink configuration				2	
Special subframe configuration				4	
Downlink power allocation	$\rho_A$	dB			0
	$\rho_B$	dB			0
	$\rho_C$	dB			-6
	$\sigma$	dB			-3
CRS reference signals				Antenna ports 0, 1	
CSI reference signals				Antenna ports 15, ..., 18	
CSI-RS periodicity and subframe offset $T_{\text{CSI-RS}} / \Delta_{\text{CSI-RS}}$				5/3	
CSI reference signal configuration				0	
Propagation condition and antenna configuration				Clause B.1 (4x8 for Rank4)	
Beamforming Model				As specified in Section B.4.3	
CodeBookSubsetRestriction bitmap				0x0001 0000 0000 0000	
SNR (Note 2)	dB	4	5	11	12
$\hat{I}_{or}^{(j)}$	dB[mW/15kHz]	-94	-93	-87	-86
$N_{oc}^{(j)}$	dB[mW/15kHz]	-98		-98	
Max number of HARQ transmissions				1	
Physical channel for CQI/PMI reporting				PUSCH (Note 3)	
PUCCH Report Type for CQI/PMI				2	
Physical channel for RI reporting				PUSCH	
PUCCH Report Type for RI				3	
Reporting periodicity	ms			$M_{pd} = 5$	
CQI delay	ms			10 or 11	
<i>cqi-pmi-ConfigurationIndex</i>				3	
<i>ri-ConfigIndex</i>				805 (Note 4)	
ACK/NACK feedback mode				Multiplexing	
Note 1:	Reference measurement channel RC.23 TDD according to Table A.4-1 with one sided dynamic OCNG Pattern OP.1 TDD as described in Annex A.5.2.1.				
Note 2:	For each test, the minimum requirements shall be fulfilled for at least one of the two SNR(s) and the respective wanted signal input level.				
Note 3:	To avoid collisions between CQI/PMI reports and HARQ-ACK it is necessary to report both on PUSCH instead of PUCCH. PDCCCH DCI format 0 shall be transmitted in downlink SF#3 and #8 to allow periodic CQI/PMI to multiplex with the HARQ-ACK on PUSCH in uplink SF#7 and #2.				
Note 4:	RI reporting interval is set to the maximum allowable length of 160ms to minimise collisions between RI, CQI/PMI and HARQ-ACK reports. In the case when all three reports collide, it is expected that CQI/PMI reports will be dropped, while RI and HARQ-ACK will be multiplexed. At eNB, CQI report collection shall be skipped every 160ms during performance verification.				

## 10 Performance requirement (MBMS)

### 10.1 FDD (Fixed Reference Channel)

The parameters specified in Table 10.1-1 are valid for all FDD tests unless otherwise stated. For the requirements defined in this section, the difference between CRS EPRE and the MBSFN RS EPRE should be set to 0 dB as the UE demodulation performance might be different when this condition is not met (e.g. in scenarios where power offsets are present, such as scenarios when reserved cells are present).



**Table 10.1-1: Common Test Parameters (FDD)**

Parameter	Unit	Value
Number of HARQ processes	Processes	None
Subcarrier spacing	kHz	15 kHz
Allocated subframes per Radio Frame (Note 1)		6 subframes
Number of OFDM symbols for PDCCH		2
Cyclic Prefix		Extended
Note1:	For FDD mode, up to 6 subframes (#1/2/3/6/7/8) are available for MBMS, in line with TS 36.331.	

All tests specified in 10.1 and 10.3 the applicability rules are defined as the following. The requirements in clause 10.3 are applicable to UEs that support FeMBMS. The test case applicability is in according to Table 10.1-2 depending on set of supported UE capabilities.

**Table 10.1-2: FeMBMS PMCH tests applicability**

Tests / clause	Applicable if UE indicates at least the following capability
10.3.1	FeMBMS support of <i>febmsMixedCell</i> and <i>unicast-febmsMixedSCell</i> with corresponding subcarrier spacing
10.3.2	FeMBMS support of <i>febmsMixedCell</i> with corresponding subcarrier spacing
10.3.3	FeMBMS support of <i>febmsDedicatedCell</i> with corresponding subcarrier spacing

For FeMBMS capable UEs, if corresponding tests listed in clause 10.1 or 10.3.1 or 10.3.2 are tested, the test coverage can be considered fulfilled without executing the corresponding tests listed in clause 10.3.3.

### 10.1.1 Minimum requirement

The receive characteristic of MBMS is determined by the BLER. The requirement is valid for all RRC states for which the UE has capabilities for MBMS.

For the parameters specified in Table 10.1-1 and Table 10.1.1-1 and Annex A.3.8.1, the average downlink SNR shall be below the specified value for the BLER shown in Table 10.1.1-2.

**Table 10.1.1-1: Test Parameters for Testing**

Parameter	Unit	Test 1-4	
Downlink power allocation	$\rho_A$	dB	0
	$\rho_B$	dB	0 (Note 1)
	$\sigma$	dB	0
$N_{oc}$ at antenna port	dBm/15kHz	-98	
Note 1:	$P_B = 0$ .		

Table 10.1.1-2: Minimum performance

Test number	Bandwidth	Reference Channel	OCNG Pattern	Propagation condition	Correlation Matrix and antenna	Reference value		MBMS UE Category
						BLER (%)	SNR(dB)	
1	10 MHz	R.37 FDD	OP.4 FDD	MBSFN channel model (Table B.2.6-1)	1x2 low	1	4.1	≥1
2	10 MHz	R.38 FDD	OP.4 FDD				11.0	≥1
3	10 MHz	R.39 FDD	OP.4 FDD				20.1	≥2
	5.0MHz	R.39-1 FDD	OP.4 FDD				20.5	1
4	1.4 MHz	R.40 FDD	OP.4 FDD				6.6	≥1

## 10.2 TDD (Fixed Reference Channel)

The parameters specified in Table 10.2-1 are valid for all TDD tests unless otherwise stated. For the requirements defined in this section, the difference between CRS EPRE and the MBSFN RS EPRE should be set to 0 dB as the UE demodulation performance might be different when this condition is not met (e.g. in scenarios where power offsets are present, such as scenarios when reserved cells are present).

Table 10.2-1: Common Test Parameters (TDD)

Parameter	Unit	Value
Number of HARQ processes	Processes	None
Subcarrier spacing	kHz	15 kHz
Allocated subframes per Radio Frame (Note 1)		5 subframes
Number of OFDM symbols for PDCCH		2
Cyclic Prefix		Extended
Note1: For TDD mode, in line with TS 36.331, Uplink-Downlink Configuration 5 is proposed, up to 5 subframes (#3/4/7/8/9) are available for MBMS.		

### 10.2.1 Minimum requirement

The receive characteristic of MBMS is determined by the BLER. The requirement is valid for all RRC states for which the UE has capabilities for MBMS.

For the parameters specified in Table 10.2-1 and Table 10.2.1-1 and Annex A.3.8.2, the average downlink SNR shall be below the specified value for the BLER shown in Table 10.2.1-2.

Table 10.2.1-1: Test Parameters for Testing

Parameter	Unit	Test 1-4	
Downlink power allocation	$\rho_A$	dB	0
	$\rho_B$	dB	0 (Note 1)
	$\sigma$	dB	0
$N_{oc}$ at antenna port	dBm/15kHz	-98	
Note 1: $P_B = 0$ .			

Table 10.2.1-2: Minimum performance

Test number	Bandwidth	Reference Channel	OCNG Pattern	Propagation condition	Correlation Matrix and antenna	Reference value		MBMS UE Category
						BLER (%)	SNR(dB)	
1	10 MHz	R.37 TDD	OP.4 TDD	MBSFN channel model (Table B.2.6-1)	1x2 low	1	3.4	≥1
2	10 MHz	R.38 TDD	OP.4 TDD				11.1	≥1
3a	10 MHz	R.39 TDD	OP.4 TDD				20.1	≥2
3b	5MHz	R.39-1 TDD	OP.4 TDD				20.5	1
4	1.4 MHz	R.40 TDD	OP.4 TDD				5.8	≥1

## 10.3 FDD (Fixed Reference Channel) with FeMBMS

For the requirements defined in this section, the difference between CRS EPRE and the MBSFN RS EPRE should be set to 0 dB for subcarrier spacing as 15kHz, 3dB for for subcarrier spacing as 7.5kHz and 10.8dB for for subcarrier spacing as 1.25kHz because the UE demodulation performance might be different when this condition is not met (e.g. in scenarios where power offsets are present, such as scenarios when reserved cells are present).

### 10.3.1 Minimum requirement for FeMBMS Unicast-mixed Cell under CA

#### 10.3.1.1 Minimum requirement with 1.25kHz subcarrier spacing

The receive characteristic of MBMS is determined by the BLER. The requirement is valid for all RRC states for which the UE has capabilities for FeMBMS Unicast-mixed Cell under CA.

For the parameters specified in Table 10.3.1.1-1 and Annex A.3.8.1, the average downlink SNR shall be below the specified value for the BLER shown in Table 10.3.1.1-2.

Table 10.3.1.1-1: Test Parameters for Testing

Parameter	Unit	Test 1-2	
Downlink power allocation	$\rho_A$	dB	0
	$\rho_B$	dB	0 (Note 1)
	$\sigma$	dB	0
$N_{oc}$ at antenna port	dBm/15kHz	-98	
PDSCH transmission mode in PCell and SCell		1	
Subcarrier spacing for SCell	kHz	1.25 kHz	
Allocated subframes per Radio Frame for SCell (Note 2)		8 subframes	
Number of OFDM symbols for PDCCH for SCell		0 (MBSFN subframes) 2 (non-MBSFN subframes)	
Cyclic Prefix for SCell in non-MBSFN subframes		Extended	
Note 1: $P_B = 0$ .			
Note 2: For SCell with FDD mode, up to 8 subframes (#1/2/3/4/6/7/8/9) are available for MBMS, in line with TS 36.331.			

Table 10.3.1.1-2: Minimum performance

Test number	Cell	Bandwidth (MHz)	Reference Channel	OCNG Pattern	Propagation condition	Correlation Matrix and antenna	Reference value		MBMS UE Category
							BLER (%)	SNR(dB)	
1	PCell	10	NA	OP.1 FDD	AWGN	1x2 low	NA	NA	NA
	SCell	10	R.81-1 FDD	OP.4A FDD	MBSFN channel model (Table B.2.6.2-1)	1x2 low	1	14.1	≥2
2	PCell	10	NA	OP.1 FDD	AWGN	1x2 low	NA	NA	NA
	SCell	10	R.81-2 FDD	OP.4A FDD	MBSFN channel model (Table B.2.6.2-1)	1x2 low	1	26.0	≥2

### 10.3.1.2 Minimum requirement with 7.5kHz subcarrier spacing

The receive characteristic of MBMS is determined by the BLER. The requirement is valid for all RRC states for which the UE has capabilities for FeMBMS Unicast-mixed Cell under CA.

For the parameters specified in Table 10.3.1.2-1 and Annex A.3.8.1, the average downlink SNR shall be below the specified value for the BLER shown in Table 10.3.1.2-2.

Table 10.3.1.2-1: Test Parameters for Testing

Parameter		Unit	Test 1
Downlink power allocation	$\rho_A$	dB	0
	$\rho_B$	dB	0 (Note 1)
	$\sigma$	dB	0
$N_{oc}$ at antenna port		dBm/15kHz	-98
PDSCH transmission mode in PCell and SCell			1
Subcarrier spacing for SCell		kHz	7.5 kHz
Allocated subframes per Radio Frame for SCell (Note 2)			8 subframes
Number of OFDM symbols for PDCCH for SCell			0 (MBSFN subframes) 2 (non-MBSFN subframes)
Cyclic Prefix for SCell in non-MBSFN subframes			Extended
Note 1: $P_B = 0$ .			
Note 2: For SCell with FDD mode, up to 8 subframes (#1/2/3/4/6/7/8/9) are available for MBMS, in line with TS 36.331.			

Table 10.3.1.2-2: Minimum performance

Test number	Cell	Bandwidth (MHz)	Reference Channel	OCNG Pattern	Propagation condition	Correlation Matrix and antenna	Reference value		MBMS UE Category
							BLER (%)	SNR(dB)	
1	PCell	10	NA	OP.1 FDD	AWGN	1x2 low	NA	NA	NA
	SCell	10	R.82-1 FDD	OP.4A FDD	MBSFN channel model (Table B.2.6.1-1)	1x2 low	1	13.9	≥2

## 10.3.2 Minimum requirement for FeMBMS Unicast-mixed Cell as Non-Serving Cell

### 10.3.2.1 Minimum requirement with 1.25kHz subcarrier spacing

The receive characteristic of MBMS is determined by the BLER. The requirement is valid for all RRC states for which the UE has capabilities for FeMBMS Unicast-mixed Cell as non-serving cell.

For the parameters specified in Table 10.3.2.1-1 and Annex A.3.8.1, the average downlink SNR shall be below the specified value for the BLER shown in Table 10.3.2.1-2.

Table 10.3.2.1-1: Test Parameters for Testing

Parameter	Unit	Test 1-4	
Downlink power allocation	$\rho_A$	dB	0
	$\rho_B$	dB	0 (Note 1)
	$\sigma$	dB	0
$N_{oc}$ at antenna port	dBm/15kHz	-98	
Subcarrier spacing	kHz	1.25 kHz	
Allocated subframes per Radio Frame (Note 2)		8 subframes	
Number of OFDM symbols for PDCCH		0 (MBSFN subframes) 2 (non-MBSFN subframes)	
Cyclic Prefix in non-MBSFN subframes		Extended	
Note 1: $P_B = 0$ .			
Note 2: For FDD mode, up to 8 subframes (#1/2/3/4/6/7/8/9) are available for MBMS, in line with TS 36.331.			

Table 10.3.2.1-2: Minimum performance

Test number	Cell	Bandwidth (MHz)	Reference Channel	OCNG Pattern	Propagation condition	Correlation Matrix and antenna	Reference value		MBMS UE Category
							BLER (%)	SNR(dB)	
1	PCell	10	NA	OP.1 FDD	AWGN	1x2 low	NA	NA	NA
	FeMBMS Unicast-mixed Cell as non-serving cell	10	R.81-1 FDD	OP.4A FDD	MBSFN channel model (Table B.2.6.2-1)	1x2 low	1	14.1	≥2
2	PCell	10	NA	OP.1 FDD	AWGN	1x2 low	NA	NA	NA
	FeMBMS Unicast-mixed Cell as non-serving cell	10	R.81-2 FDD	OP.4A FDD	MBSFN channel model (Table B.2.6.2-1)	1x2 low	1	26.0	≥2

### 10.3.2.2 Minimum requirement with 7.5kHz subcarrier spacing

The receive characteristic of MBMS is determined by the BLER. The requirement is valid for all RRC states for which the UE has capabilities for enhanced FeMBMS Unicast-mixed Cell as non-serving cell.

For the parameters specified in Table 10.3.2.2-1 and Annex A.3.8.1, the average downlink SNR shall be below the specified value for the BLER shown in Table 10.3.2.2-2.

Table 10.3.2.2-1: Test Parameters for Testing

Parameter	Unit	Test 1-4	
Downlink power allocation	$\rho_A$	dB	0
	$\rho_B$	dB	0 (Note 1)
	$\sigma$	dB	0
$N_{oc}$ at antenna port	dBm/15kHz	-98	
Subcarrier spacing	kHz	7.5 kHz	
Allocated subframes per Radio Frame (Note 2)		8 subframes	
Number of OFDM symbols for PDCCH		0 (MBSFN subframes) 2 (non-MBSFN subframes)	
Cyclic Prefix in non-MBSFN subframes		Extended	
Note 1: $P_B = 0$ .			
Note 2: For FDD mode, up to 8 subframes (#1/2/3/4/6/7/8/9) are available for MBMS, in line with TS 36.331.			

Table 10.3.2.2-2: Minimum performance

Test number	Cell	Bandwidth (MHz)	Reference Channel	OCNG Pattern	Propagation condition	Correlation Matrix and antenna	Reference value		MBMS UE Category
							BLER (%)	SNR(dB)	
1	PCell	10	NA	OP.1 FDD	AWGN	1x2 low	NA	NA	NA
	FeMBMS Unicast-mixed Cell as non-serving cell	10	R.82-1 FDD	OP.4A FDD	MBSFN channel model (Table B.2.6.1-1)	1x2 low	1	13.9	≥2

### 10.3.3 Minimum requirement for MBMS Dedicated cell

#### 10.3.3.1 Minimum requirement with 1.25kHz subcarrier spacing

The receive characteristic of MBMS is determined by the BLER. The requirement is valid for all RRC states for which the UE has capabilities for MBMS Dedicated Cell.

For the parameters specified in Table 10.3.3.1-1 and Annex A.3.8.1, the average downlink SNR shall be below the specified value for the BLER shown in Table 10.3.3.1-2.

Table 10.3.3.1-1: Test Parameters for Testing MBMS Dedicated Cell

Parameter	Unit	Test 1-2	
Downlink power allocation	$\rho_A$	dB	0
	$\rho_B$	dB	0 (Note 1)
	$\sigma$	dB	0
$N_{oc}$ at antenna port	dBm/1.25kHz	-98	
PDSCH transmission mode in PCell		1	
Subcarrier spacing for MBMS Dedicated Cell	kHz	1.25 kHz	
Allocated subframes per Radio Frame for MBMS Dedicated Cell (Note 2)		10 subframes	
Number of OFDM symbols for PDCCH for MBMS Dedicated Cell		0 (MBSFN subframes) 2 (non-MBSFN subframes)	
Cyclic Prefix for CAS in MBMS Dedicated Cell		Extended	
Note 1: $P_B = 0$ .			
Note 2: All subframes are MBSFN subframes except CAS			

Table 10.3.3.1-2: Minimum performance for MBMS dedicated Cell

Test number	Cell	Bandwidth (MHz)	Reference Channel	OCNG Pattern	Propagation condition	Correlation Matrix and antenna	Reference value		MBMS UE Category
							BLER (%)	SNR(dB)	
1	PCell	10	NA	OP.1 FDD	AWGN	1x2 low	NA	NA	NA
	MBMS Dedicated Cell	10	R.83-1 FDD	NA	MBSFN channel model (Table B.2.6.2-1)	1x2 low	1	14.1	≥2
2	PCell	10	NA	OP.1 FDD	AWGN	1x2 low	NA	NA	NA
	MBMS Dedicated Cell	10	R.83-2 FDD	NA	MBSFN channel model (Table B.2.6.2-1)	1x2 low	1	26.0	≥2

### 10.3.3.2 Minimum requirement with 7.5kHz subcarrier spacing

The receive characteristic of MBMS is determined by the BLER. The requirement is valid for all RRC states for which the UE has capabilities for MBMS Dedicated Cell.

For the parameters specified in Table 10.3.3.2-1 and Annex A.3.8.1, the average downlink SNR shall be below the specified value for the BLER shown in Table 10.3.3.2-2.

Table 10.3.3.2-1: Test Parameters for Testing MBMS Dedicated Cell

Parameter		Unit	Test 1
Downlink power allocation	$\rho_A$	dB	0
	$\rho_B$	dB	0 (Note 1)
	$\sigma$	dB	0
$N_{oc}$ at antenna port		dBm/1.25kHz	-98
PDSCH transmission mode in PCell			1
Subcarrier spacing for MBMS Dedicated Cell		kHz	7.5 kHz
Allocated subframes per Radio Frame for MBMS Dedicated Cell (Note 2)			10 subframes
Number of OFDM symbols for PDCCH for MBMS Dedicated Cell			0 (MBSFN subframes) 2 (non-MBSFN subframes)
Cyclic Prefix for CAS in MBMS Dedicated Cell			Extended
Note 1: $P_B = 0$ .			
Note 2: All subframes are MBSFN subframes except CAS			



**Table 10.3.3.2-2: Minimum performance for MBMS dedicated Cell**

Test number	Cell	Bandwidth (MHz)	Reference Channel	OCNG Pattern	Propagation condition	Correlation Matrix and antenna	Reference value		MBMS UE Category
							BLER (%)	SNR(dB)	
1	PCell	10	NA	OP.1 FDD	AWGN	1x2 low	NA	NA	NA
	MBMS Dedicated Cell	10	R.84-1 FDD	NA	MBSFN channel model (Table B.2.6.1-1)	1x2 low	1	13.9	≥2

### 10.3.3.3 Minimum requirement with 15kHz subcarrier spacing

The receive characteristic of MBMS is determined by the BLER. The requirement is valid for all RRC states for which the UE has capabilities for MBMS Dedicated Cell.

For the parameters specified in Table 10.3.3.3-1 and Annex A.3.8.1, the average downlink SNR shall be below the specified value for the BLER shown in Table 10.3.3.3-2.

**Table 10.3.3.3-1: Test Parameters for Testing MBMS Dedicated Cell**

Parameter	Unit	Test 1-3	
Downlink power allocation	$\rho_A$	dB	0
	$\rho_B$	dB	0 (Note 1)
	$\sigma$	dB	0
$N_{oc}$ at antenna port	dBm/1.25kHz	-98	
PDSCH transmission mode in PCell		1	
Subcarrier spacing for MBMS Dedicated Cell	kHz	15 kHz	
Allocated subframes per Radio Frame for MBMS Dedicated Cell (Note 2)		10 subframes	
Number of OFDM symbols for PDCCH for MBMS Dedicated Cell		0 (MBSFN subframes) 2 (non-MBSFN subframes)	
Cyclic Prefix for MBMS Dedicated Cell		Extended	
Note 1: $P_B = 0$ .			
Note 2: All subframes are MBSFN subframes			

Table 10.3.3.3-2: Minimum performance for MBMS dedicated Cell

Test number	Cell	Bandwidth (MHz)	Reference Channel	OCNG Pattern	Propagation condition	Correlation Matrix and antenna	Reference value		MBMS UE Category
							BLER (%)	SNR(dB)	
1	PCell	10	NA	OP.1 FDD	AWGN	1x2 low	NA	NA	NA
	MBMS Dedicated Cell	3	R.85-1 FDD	NA	MBSFN channel model (Table B.2.6.1-1)	1x2 low	1	7.0	≥2
2	PCell	10	NA	OP.1 FDD	AWGN	1x2 low	NA	NA	NA
	MBMS Dedicated Cell	5	R.85-2 FDD	NA	MBSFN channel model (Table B.2.6.1-1)	1x2 low	1	13.5	≥2
3	PCell	10	NA	OP.1 FDD	AWGN	1x2 low	NA	NA	NA
	MBMS Dedicated Cell	10	R.85-3 FDD	NA	MBSFN channel model (Table B.2.6.1-1)	1x2 low	1	22.3	≥2

## 10.4 FDD with 5G terrestrial broadcast

For all tests in section 10.4 the applicability rules are defined in Table 10.4-1 depending on the capabilities of the UE. The requirements in clause 10.4 are applicable to UEs that support 5G terrestrial broadcast.

Table 10.4-1: 5G terrestrial broadcast tests applicability

Tests	Applicable if UE supports at least the following capability
Table 10.4.1.1-2 test 1	5G terrestrial broadcast support of <i>mbms-ScalingFactor0dot37-r16</i> and <i>timeSeparationSlot4-r16</i>
Table 10.4.1.1-2 test 2	5G terrestrial broadcast support of <i>mbms-ScalingFactor0dot37-r16</i> and <i>timeSeparationSlot2-r16</i>
Table 10.4.1.2-2 test 1	5G terrestrial broadcast support of <i>mbms-ScalingFactor2dot5-r16</i>
Table 10.4.2.1-1 test 1	5G terrestrial broadcast support of <i>mbms-ScalingFactor0dot37-r16</i> and 5G terrestrial broadcast support of PBCH repetition in CAS
Table 10.4.2.1-1 test 2	5G terrestrial broadcast support of <i>mbms-ScalingFactor2dot5-r16</i> and 5G terrestrial broadcast support of PBCH repetition in CAS

For the requirements defined in this section, the difference between CRS EPRE and the MBSFN RS EPRE should be set to 16dB for subcarrier spacing as 0.37kHz, 7.8 dB for subcarrier spacing as 2.5kHz because the UE demodulation performance might be different when this condition is not met (e.g. in scenarios where power offsets are present, such as scenarios when reserved cells are present).

### 10.4.1 Minimum requirement for PMCH decoding

#### 10.4.1.1 Minimum requirement with 0.37kHz subcarrier spacing

The receive characteristic of MBMS is determined by the BLER.

For the parameters specified in Table 10.4.1.1-1 and Table A.3.8.1-9, the average downlink SNR shall be below the specified value for the BLER shown in Table 10.4.1.1-2.

**Table 10.4.1.1-1: Test Parameters for Testing**

Parameter		Unit	
Downlink power allocation	$\rho_A$	dB	0
	$\rho_B$	dB	0 (Note 1)
	$\sigma$	dB	0
$N_{oc}$ at antenna port		dBm/15kHz	-98
PDSCH transmission mode in PCell			1
Subcarrier spacing for MBSFN cell		kHz	0.37 kHz
Bandwidth		MHz	10(Note 2)
Note 1: $P_B = 0$ .			
Note 2: For both Pcell and Scell.			

**Table 10.4.1.1-2: Minimum performance**

Test number	Cell	Bandwidth (MHz)	Reference Channel	MBSFN RS type	OCN G Pattern	Propagation condition	Correlation Matrix and antenna	Reference value		MBMS UE Category
								BLER (%)	SNR(dB)	
1	PCell	10	N/A	N/A	OP.1 FDD	AWGN	1x1	N/A	N/A	N/A
	MBMS Dedicated Cell	10	R.106-1 FDD	Type 1	N/A	MBSFN channel model (Table B.2.6.3-1)	1x1	1	18.5	$\geq 2$
2	PCell	10	N/A	N/A	OP.1 FDD	AWGN	1x1	N/A	N/A	N/A
	MBMS Dedicated Cell	10	R.106-2 FDD	Type 2	N/A	MBSFN channel model (Table B.2.6.3-1)	1x1	1	20.2	$\geq 2$

#### 10.4.1.2 Minimum requirement with 2.5kHz subcarrier spacing

The receive characteristic of MBMS is determined by the BLER.

For the parameters specified in Table 10.4.1.2-1 and Table A.3.8.1-10, the average downlink SNR shall be below the specified value for the BLER shown in Table 10.4.1.2-2.

**Table 10.4.1.2-1: Test Parameters for Testing**

Parameter		Unit	
Downlink power allocation	$\rho_A$	dB	0
	$\rho_B$	dB	0 (Note 1)
	$\sigma$	dB	0

$N_{oc}$ at antenna port	dBm/15kHz	$N_{oc}$ at antenna port
PDSCH transmission mode in PCell		1
Subcarrier spacing for MBSFN cell	kHz	2.5 kHz
Bandwidth	MHz	10(Note 2)
Note 1: $P_B = 0$ .		
Note 2: For both Pcell and Scell.		

Table 10.4.1.2-2: Minimum performance

Test number	Cell	Bandwidth (MHz)	Reference Channel	OCNG Pattern	Propagation condition	Correlation Matrix and antenna	Reference value		MBMS UE Category
							BLER (%)	SNR(dB)	
1	PCell	10	N/A	OP.1 FDD	AWGN	1x2 low	N/A	N/A	N/A
	MBMS Dedicated Cell	10	R.107 FDD	N/A	MBSFN channel model (Table B.2.6.4-1)	1x2 low	1	12.9	$\geq 2$

## 10.4.2 Minimum requirement for CAS detection

### 10.4.2.1 Minimum requirement for PBCH detection

For the parameters specified in Table 8.6.1-1, the average probability of a miss-detected PBCH ( $P_{m-bch}$ ) shall be below the specified value in Table 10.4.2.1-1. The downlink physical setup is in accordance with Annex C.3.2.

Table 10.4.2.1-1: Minimum performance

Test number	Cell	Bandwidth (MHz)	Reference Channel	OCNG Pattern	Propagation condition	Correlation Matrix and antenna	Reference value		MBMS UE Category
							$P_{m-bch}$ (%)	SNR(dB)	
1	PCell	10	N/A	OP.1 FDD	AWGN	1x1 low	N/A	N/A	N/A
	MBMS Dedicated Cell	10	R.23-1	N/A	AWGN	1x1 low	1	-7.2	$\geq 2$
2	PCell	10	N/A	OP.1 FDD	AWGN	1x2 low	N/A	N/A	N/A
	MBMS Dedicated Cell	10	R.23-1	N/A	EVA 162Hz	1x2 low	1	-6.7	$\geq 2$

## 11 Performance requirement (ProSe Direct Discovery)

This clause contains the performance requirements for the Sidelink physical channels specified for ProSe Direct Discovery.

## 11.1 General

### 11.1.1 Applicability of requirements

The requirements in this clause are applicable to UEs that support ProSe Direct Discovery. The test case applicability is in according to table 11.1.1-1 depending on set of supported UE capabilities.

**Table 11.1.1-1: ProSe Direct Discovery test applicability**

FDD/TDD	Tests / clause	Applicable if UE indicates at least the following capability
FDD	11.2.1	ProSe Direct Discovery without support of <i>disc-SLSS-r12</i>
	11.2.3	ProSe Direct Discovery with support of <i>discPeriodicSLSS-r13</i> and ProSe Direct Communication
	11.3.1	ProSe Direct Discovery
	11.4.1	ProSe Direct Discovery with support of <i>disc-SLSS-r12</i>
	11.5.1	ProSe Direct Discovery
TDD	11.2.2	ProSe Direct Discovery
	11.3.2	ProSe Direct Discovery
	11.5.2	ProSe Direct Discovery

For maximum Sidelink Processes test specified in clause 11.5, the UE is required to only meet the test for the maximum channel bandwidth over the ProSe operating bands supported by the UE. Test case 11.2.3 for 5MHz channel bandwidth is applicable to UEs that support ProSe Direct Communication on Band 31 only.

### 11.1.2 Reference DRX configuration

**Table 11.1.2-1: Reference DRX configuration**

Parameter	Value	Comments
onDurationTimer	psf1	
drx-InactivityTimer	psf1	
drx-RetransmissionTimer	psf1	
longDRX-CycleStartOffset	sf2560_0	
shortDRX	disabled	
NOTE 1: For further information see clause 6.3.2 in TS 36.331.		

## 11.2 Demodulation of PSDCH (single link performance)

The purpose of the requirements in this subclause is to verify the PSDCH demodulation performance with a single active PSDCH link under different operating scenarios and channel conditions.

The active cell(s), when present, are specified in the test parameters specific to the test.

### 11.2.1 FDD (in-coverage)

The minimum requirements are specified in Table 11.2.1-2 with the test parameters specified in Table 11.2.1-1. The receiver UE under test is associated with Cell 1.

Table 11.2.1-1: Test Parameters

Parameter		Unit	Test 1	
Discovery resource pool configuration			As specified in Table A.7.1.1-1 (Configuration #1-FDD)	
DRX configuration			As specified in Table 11.1.2-1	
$N_{oc}$ at antenna port (NOTE 3)		dBm/15kHz	-98	
Active cell(s)			Cell 1 (Serving cell)	
Cell 1	Cyclic prefix		Normal	
	Cell ID		0	
	Downlink power allocation	$\rho_A$	dB	0
		$\rho_B$	dB	0 (NOTE 1)
		$\sigma$	dB	0
	OCNG Pattern (NOTE 2)			OP.1 FDD
	Propagation channel			AWGN
Antenna configuration			1x2	
RSRP		dBm/15kHz	-92	
Active Sidelink UE(s)			Sidelink UE 1	
Sidelink UE 1	Sidelink Transmissions		PSDCH	
	PSDCH RB allocation		PRB pairs $\{2i..2i+1\}$ , where $i$ is chosen randomly uniformly from $[0,11]$ in each discovery period.	
	Time offset (NOTE 4)	$\mu$ s	+1	
	Frequency offset (NOTE 5)	Hz	+200	
	Propagation Channel			EPA5
	Antenna configuration			1x2 Low
NOTE 1: $P_B = 0$ .				
NOTE 2: OCNG is used to fully allocate the available resource blocks to virtual UEs.				
NOTE 3: Applicable to both DL channel and ProSe Direct Discovery Subframes on UL.				
NOTE 4: Time offset of Sidelink UE receive signal with respect to Cell 1 downlink timing at the tested UE.				
NOTE 5: Frequency offset of Sidelink UE with respect to Cell 1 uplink frequency.				

Table 11.2.1-2: Minimum performance

Test num.	Sidelink UE	Band-width	Reference channel	Reference value	
				BLER of PSDCH (%)	SNR (dB)
1	1	5 MHz	D.1 FDD	30	4.6

## 11.2.2 TDD (in-coverage)

The minimum requirements are specified in Table 11.2.2-2 with the test parameters specified in Table 11.2.2-1. The receiver UE under test is associated with Cell 1.

Table 11.2.2-1: Test Parameters

Parameter		Unit	Test 1	
Discovery resource pool configuration			As specified in Table A.7.1.2-1 (Configuration #1-TDD)	
DRX configuration			As specified in Table 11.1.2-1	
$N_{oc}$ at antenna port (NOTE 5)		dBm/15kHz	-98	
Active cell(s)			Cell 1 (Serving cell)	
Cell 1	Cyclic prefix		Normal	
	Uplink downlink configuration (NOTE 3)		0	
	Special subframe configuration (NOTE 4)		4	
	Cell ID		0	
	Downlink power allocation	$\rho_A$	dB	0
		$\rho_B$	dB	0 (NOTE 1)
		$\sigma$	dB	0
	OCNG Pattern <sup>NOTE 2</sup>		OP.1 TDD	
	Propagation channel		AWGN	
	Antenna configuration		1x2	
RSRP	dBm/15kHz	-92		
Active Sidelink UE(s)			Sidelink UE 1	
Sidelink UE 1	Sidelink Transmissions		PSDCH	
	RB allocation		PRB pairs $\{2i..2i+1\}$ , where $i$ is chosen randomly uniformly from $[0,11]$ in each discovery period.	
	Time offset (NOTE 6)	$\mu$ s	+1	
	Frequency offset (NOTE 7)	Hz	+200	
	Propagation Channel		EPA5	
	Antenna configuration		1x2 Low	
NOTE 1: $P_B = 0$ .				
NOTE 2: OCNG is used to fully allocate the available resource blocks to virtual UEs.				
NOTE 3: As specified in Table 4.2-2 in TS 36.211 [4].				
NOTE 4: As specified in Table 4.2-1 in TS 36.211 [4].				
NOTE 5: Applicable to both DL subframes and UL subframes configured for ProSe Direct Discovery.				
NOTE 6: Time offset of Sidelink UE receive signal with respect to Cell 1 downlink timing at the tested UE.				
NOTE 7: Frequency offset of Sidelink UE with respect to Cell 1 uplink frequency.				

Table 11.2.2-2: Minimum performance

Test num.	Sidelink UE	Band-width	Reference channel	Reference value	
				BLER of PSDCH (%)	SNR (dB)
1	1	5 MHz	D.1 TDD	30	4.6

### 11.2.3 FDD (out-of-coverage)

The minimum requirements are specified in Table 11.2.3-2 with the test parameters specified in Table 11.2.3-1. The receiver UE under test is out of network coverage.

Table 11.2.3-1: Test Parameters

Parameter	Unit	Test 1	
Resource pool configuration		As specified in Table A.7.1.1-4 (Configuration #4-FDD)	
DRX configuration		As specified in Table 11.1.2-1	
$N_{oc}$ at antenna port	dBm/15kHz	-98	
Active cell(s)		None	
Active Sidelink UE(s)		Sidelink UEs 1, 2	
Sidelink UE 1	Sidelink Transmissions	SLSS + PSBCH	
	networkControlledSyncTx	ON	
	slssid	30	
	inCoverage (in MIB-SL)	TRUE	
	syncOffsetIndicator	Set same as syncOffsetIndicator1 in Configuration #4-FDD	
	Propagation channel	EPA5	
	Antenna configuration	1x2 Low	
$E_s$ at antenna port	dBm/15kHz	-82	
Sidelink UE 2	Sidelink Transmissions	PSDCH	
	PSDCH RB allocation	PRB pairs $\{2i..2i+1\}$ , where $i$ is chosen randomly uniformly from $[0,11]$ (for 5MHz) or $[0,24]$ (for 10MHz) in each discovery period.	
	Time offset (Note 1)	$\mu$ s	+1
	Frequency offset (Note 2)	Hz	+200
	Propagation Channel		EPA5
Antenna configuration		1x2 Low	
NOTE 1: Time offset of Sidelink UE 2 receive signal timing with respect to Sidelink UE 1 receive signal timing at the tested UE.			
NOTE 2: Frequency offset of Sidelink UE 2 with respect to Sidelink UE 1 transmit frequency.			

Table 11.2.3-2: Minimum performance

Test number	Sidelink UE	Band-width	Reference channel	Reference value	
				BLER of PSDCH (%)	SNR (dB)
1	1	5 MHz	D.1 FDD	30	4.6
		10 MHz			

## 11.3 Power imbalance performance with two links

The purpose of this test is to check the demodulation performance when receiving PSDCH transmissions from two Sidelink UEs with power imbalance in one subframe.

### 11.3.1 FDD

The minimum requirements are specified in Table 11.3.1-2 with the test parameters specified in Table 11.3.1-1. The receiver UE under test is associated with Cell 1. The Sidelink UE 1 and 2 are synchronized to Cell 1 and transmit PSDCH on adjacent RBs.



Table 11.3.1-1: Test Parameters

Parameter		Unit	Test 1	
Discovery resource pool configuration			As specified in Table A.7.1.1-1 (Configuration #1-FDD)	
DRX configuration			As specified in Table 11.1.2-1	
$N_{oc}$ at antenna port (NOTE 3)		dBm/15kHz	-98	
Active cell(s)			Cell 1 (Serving cell)	
Cell 1	Cyclic prefix		Normal	
	Cell ID		0	
	Downlink power allocation	$\rho_A$	dB	0
		$\rho_B$	dB	0 (NOTE 1)
		$\sigma$	dB	0
	OCNG Pattern (NOTE 2)			OP.1 FDD
	Propagation channel			AWGN
Antenna configuration			1x2	
RSRP		dBm/15kHz	-92	
Active Sidelink UE(s)			Sidelink UE 1, Sidelink UE 2	
Sidelink UE 1	Sidelink Transmissions		PSDCH	
	PSDCH RB allocation		PRB pairs {4..5}	
	Time offset (NOTE 3)	$\mu$ s	0	
	Frequency offset (NOTE 4)	Hz	0	
	Propagation Channel		AWGN	
Antenna configuration			1x2 Low	
Sidelink UE 2	Sidelink Transmissions		PSDCH	
	PSDCH RB allocation		PRB pairs {6..7}	
	Time offset (w.r.t. Cell 1 DL)	$\mu$ s	0	
	Frequency offset (w.r.t. Cell 1 UL)	Hz	0	
	Propagation Channel		AWGN	
Antenna configuration			1x2 Low	
NOTE 1: $P_B = 0$ .				
NOTE 2: OCNG is used to fully allocate the available resource blocks to virtual UEs.				
NOTE 3: Applicable to both DL channel and ProSe Direct Discovery Subframes on UL.				
NOTE 4: Time offset of Sidelink UE receive signal with respect to Cell 1 downlink timing at the tested UE.				
NOTE 5: Frequency offset of Sidelink UE with respect to Cell 1 uplink frequency.				

Table 11.3.1-2: Minimum performance

Test num.	Band-width	Sidelink UE	Reference channel	Reference value	
				BLER of PSDCH (%)	SNR (dB)
1	5 MHz	1	D.1 FDD	(NOTE 1)	24.3
		2	D.1 FDD	30	6.9
NOTE 1: There is no BLER requirement for Sidelink UE 1.					

## 11.3.2 TDD

The minimum requirements are specified in Table 11.3.2-2 with the test parameters specified in Table 11.3.2-1. The receiver UE under test is associated with Cell 1. The Sidelink UE 1 and 2 are synchronized to Cell 1 and transmit PSDCH on adjacent RBs.

Table 11.3.2-1: Test Parameters

Parameter		Unit	Test 1	
Discovery resource pool configuration			As specified in Table A.7.1.2-1 (Configuration #1-TDD)	
DRX configuration			As specified in Table 11.1.2-1	
$N_{oc}$ at antenna port (NOTE 5)		dBm/15kHz	-98	
Active cell(s)			Cell 1 (Serving cell)	
Cell 1	Cyclic prefix		Normal	
	Uplink downlink configuration (NOTE 3)		0	
	Special subframe configuration (NOTE 4)		4	
	Cell ID		0	
	Downlink power allocation	$\rho_A$	dB	0
		$\rho_B$	dB	0 (NOTE 1)
		$\sigma$	dB	0
	OCNG Pattern <sup>NOTE 2</sup>			OP.1 TDD
	Propagation channel			AWGN
	Antenna configuration			1x2
RSRP		dBm/15kHz	-92	
Active Sidelink UE(s)			Sidelink UE 1, Sidelink UE 2	
Sidelink UE 1	Sidelink Transmissions		PSDCH	
	PSDCH RB allocation		PRB pairs {4..5}	
	Time offset (NOTE 6)		$\mu$ s	0
	Frequency offset (NOTE 7)		Hz	0
	Propagation Channel			AWGN
	Antenna configuration			1x2 Low
	Sidelink UE 2	Sidelink Transmissions		PSDCH
RB allocation		PRB pairs {6..7}		
Time offset (NOTE 6)		$\mu$ s	0	
Frequency offset (NOTE 7)		Hz	0	
Propagation Channel			AWGN	
Antenna configuration			1x2 Low	
NOTE 1: $P_B = 0$ .				
NOTE 2: OCNG is used to fully allocate the available resource blocks to virtual UEs.				
NOTE 3: As specified in Table 4.2-2 in TS 36.211 [4].				
NOTE 4: As specified in Table 4.2-1 in TS 36.211 [4].				
NOTE 5: Applicable to both DL subframes and UL subframes configured for ProSe Direct Discovery.				
NOTE 6: Time offset of Sidelink UE receive signal with respect to Cell 1 downlink timing at the tested UE.				
NOTE 7: Frequency offset of Sidelink UE with respect to Cell 1 uplink frequency.				

Table 11.3.2-2: Minimum performance

Test num.	Band-width	Sidelink UE	Reference channel	Reference value	
				BLER of PSDCH (%)	SNR (dB)
1	5 MHz	1	D.1 TDD	(NOTE 1)	24.3
		2	D.1 TDD	30	6.9

NOTE 1: There is no BLER requirement for Sidelink UE 1.

## 11.4 Multiple timing reference test

The purpose of this test is to check the demodulation performance when receiving from two Sidelink UEs that follow different timing references and transmitting on different resources (non-overlapping in time).

## 11.4.1 FDD

The test parameters are specified in Table 11.4.1-1. Sidelink UE 2 and the receiver UE under test are associated with Cell 1. Sidelink UE 1 and 3 are associated with another cell and use a different timing, and UE 1 acts as a synchronization reference. The minimum requirements are specified in Table 11.4.1-2.

Table 11.4.1-1: Test Parameters

Parameter		Unit	Test 1	
Discovery resource pool configuration			As specified in Table A.7.1.1-2 (Configuration #2-FDD)	
DRX configuration			As specified in Table 11.1.2-1	
$N_{oc}$ at antenna port (NOTE 3)		dBm/15kHz	-98	
Active cell(s)			Cell 1 (Serving cell)	
Cell 1	Cyclic prefix		Normal	
	Cell ID		0	
	Downlink power allocation	$\rho_A$	dB	0
		$\rho_B$	dB	0 (NOTE 1)
		$\sigma$	dB	0
	OCNG Pattern <sup>NOTE 2</sup>			OP.1 FDD
	Propagation channel			AWGN
	Antenna configuration			1x2
RSRP		dBm/15kHz	-92	
Active Sidelink UE(s)			Sidelink UEs 1, 2, 3	
Sidelink UE 1	Sidelink Transmissions		SLSS	
	networkControlledSyncTx		ON	
	slssid		30	
	Time offset (NOTE 4)		$\mu$ s	3511
	Frequency offset (NOTE 5)		Hz	-100
	Propagation channel			EPA5
	Antenna configuration			1x2 Low
	$E_s$ of SLSS at antenna port		dBm/15kHz	-82
Sidelink UE 2	Sidelink Transmissions		PSDCH	
	Resource pool used for transmissions		<i>discRxPool(0)</i>	
	RB allocation		PRB pairs $\{2i..2i+1\}$ , where $i$ is chosen randomly uniformly from $[0,11]$ in each discovery period.	
	Time offset (NOTE 4)		$\mu$ s	+1
	Frequency offset (NOTE 5)		Hz	+200
	Propagation Channel			EPA5
Antenna configuration			1x2 Low	
Sidelink UE 3	Sidelink Transmissions		PSDCH	
	Resource pool used for transmissions		<i>discRxPool(1)</i>	
	RB allocation		PRB pairs $\{2i..2i+1\}$ , where $i$ is chosen randomly uniformly from $[0,11]$ in each discovery period.	
	Time offset (NOTE 4)		$\mu$ s	3511
	Frequency offset (NOTE 5)		Hz	+300
	Propagation Channel			EPA5
Antenna configuration			1x2 Low	
NOTE 1: $P_B = 0$ .				
NOTE 2: OCNG is used to fully allocate the available resource blocks to virtual UEs.				
NOTE 3: Applicable to both DL channel and ProSe Direct Discovery Subframes on UL.				
NOTE 4: Time offset of Sidelink UE receive signal with respect to Cell 1 downlink timing at the tested UE.				
NOTE 5: Frequency offset of Sidelink UE with respect to Cell 1 uplink frequency.				

Table 11.4.1-2: Minimum performance

Test num.	Band-width	Sidelink UE	Reference channel	Reference value	
				BLER of PSDCH (%) <sup>NOTE 1</sup>	SNR (dB)
1	5 MHz	2	D.1 FDD	30	4,6
		3	D.1 FDD	30	4,6

NOTE 1: The BLER is measured after 5 D2D Discovery periods (1600 frames) of lead time during which the test UE detects and synchronizes to Sidelink UE 1 SLSS.

## 11.5 Maximum Sidelink processes test

The purpose of this test is to verify the maximum number of Sidelink processes supported by the UE as reported using UE capability signalling (*discSupportedProc*).

The UE is required to meet only the test for the maximum channel bandwidth over the ProSe operating bands supported by the UE.

### 11.5.1 FDD

The test parameters are specified in Table 11.5.1-1. Multiple discovery resource pools are interleaved. Each Sidelink UE transmits in one of the resource pools with 3 retransmissions. The minimum requirements are specified in Table 11.5.1-2.

Table 11.5.1-1: Test Parameters

Parameter		Unit	Test 1-7	
Discovery resource pool configuration			As specified in Table A.7.1.1-3 (Configuration #3-FDD) with parameters $BW_{\text{Channel}}$ , $N_{\text{Pools}}$ = Number of configured resource pools (as specified in Table 11.5.1-2), and $N = \text{discSupportedProc}$	
DRX configuration			As specified in Table 11.1.2-1	
Active cell(s)			Cell 1 (Serving cell)	
Cell 1	Cyclic prefix		Normal	
	Cell ID		0	
	Downlink power allocation	$\rho_A$	dB	0
		$\rho_B$	dB	0 (NOTE 1)
		$\sigma$	dB	0
	OCNG Pattern <small>NOTE 2</small>		OP.1 FDD	
	Propagation channel		Static propagation condition No external noise sources are applied	
Antenna configuration		1x2		
RSRP	dBm/15kHz		-85	
Active Sidelink UE(s)			Sidelink UE $i$ , $i = 0, \dots, \text{discSupportedProc}-1$	
Sidelink UE $i$	Sidelink Transmissions		PSDCH (D.1 FDD)	
	Resource pool index (NOTE 3)		$\left\lfloor \frac{i}{N_{\text{MAX\_SF}}} \right\rfloor$	
	PSDCH RB allocation (NOTE 3)		PRB pairs $\{2*(i \% N_{\text{MAX\_SF}}), 2*(i \% N_{\text{MAX\_SF}})+1\}$	
	Time offset (NOTE 4)	$\mu\text{s}$	0	
	Frequency offset (NOTE 4)	Hz	0	
	Propagation Channel		Static propagation condition No external noise sources are applied	
	Antenna configuration		1x2 Low	
NOTE 1: $P_B = 0$ .				
NOTE 2: OCNG is used to fully allocate the available resource blocks to virtual UEs..				
NOTE 3: $N_{\text{MAX\_SF}}$ represents the maximum number of Sidelink UEs transmitting in one subframe. $N_{\text{MAX\_SF}} = 12$ (5 MHz), 25 (10MHz), 37 (15MHz), 50 (10MHz).				
NOTE 4: Time offset of Sidelink UE receive signal with respect to Cell 1 downlink timing at the tested UE.				
NOTE 5: Frequency offset of Sidelink UE with respect to Cell 1 uplink frequency.				

Table 11.5.1-2: Minimum performance

Test num.	Bandwidth	discSupportedProc	Number of configured resource pools	$\hat{E}_s$ at antenna port (dBm/15kHz)	Reference value for Sidelink UE $i=0\dots\text{discSupportedProc}-1$
					Fraction of maximum throughput (%)
1	5 MHz	50	5	-85	95
2	10 MHz	50	2	-85	95
3	15 MHz	50	2	-85	95
4	20 MHz	50	1	-85	95
5	10 MHz	400	16	-85	95
6	15 MHz	400	11	-85	95
7	20 MHz	400	8	-85	95

## 11.5.2 TDD

The test parameters are specified in Table 11.5.2-1. Multiple discovery resource pools are interleaved. Each Sidelink UE transmits in one of the resource pools with 3 retransmissions. The minimum requirements are specified in Table 11.5.2-2.

Table 11.5.2-1: Test Parameters

Parameter		Unit	Test 1-7	
Discovery resource pool configuration			As specified in Table A.7.1.2-2 (Configuration #2-TDD) with parameters $BW_{Channel}$ , $N_{Pools}$ = Number of configured resource pools (as specified in Table 11.5.2-2), and $N = discSupportedProc$	
DRX configuration			As specified in Table 11.1.2-1	
Active cell(s)			Cell 1 (Serving cell)	
Cell 1	Cyclic prefix		Normal	
	Uplink downlink configuration (NOTE 3)		0	
	Special subframe configuration (NOTE 4)		4	
	Cell ID		0	
	Downlink power allocation	$\rho_A$	dB	0
		$\rho_B$	dB	0 (NOTE 1)
		$\sigma$	dB	0
	OCNG Pattern <sup>NOTE 2</sup>		OP.1 TDD	
	Propagation channel		Static propagation condition No external noise sources are applied	
	Antenna configuration		1x2	
RSRP		dBm/15kHz	-85	
Active Sidelink UE(s)			Sidelink UE $i$ , $i = 0, \dots, discSupportedProc-1$	
Sidelink UE $i$	Sidelink Transmissions		PSDCH (D.1 TDD)	
	PSDCH Resource pool (NOTE 5)		$\left\lfloor \frac{i}{N_{MAX\_SF}} \right\rfloor$	
	PSDCH RB allocation (NOTE 5)		PRB pairs $\{2*(i \% N_{MAX\_SF}), 2*(i \% N_{MAX\_SF})+1\}$	
	Time offset (NOTE 6)		$\mu s$	0
	Frequency offset (NOTE 7)		Hz	0
	Propagation Channel		Static propagation condition No external noise sources are applied	
	Antenna configuration		1x2 Low	
NOTE 1: $P_B = 0$ .				
NOTE 2: OCNG is used to fully allocate the available resource blocks to virtual UEs.				
NOTE 3: As specified in Table 4.2-2 in TS 36.211 [4].				
NOTE 4: As specified in Table 4.2-1 in TS 36.211 [4].				
NOTE 5: $N_{MAX\_SF}$ represents the maximum number of Sidelink UEs transmitting in one subframe. $N_{MAX\_SF} = 12$ (5 MHz), 25 (10MHz), 37 (15MHz), 50 (10MHz).				
NOTE 6: Time offset of Sidelink UE receive signal with respect to Cell 1 downlink timing at the tested UE.				
NOTE 7: Frequency offset of Sidelink UE with respect to Cell 1 uplink frequency.				

Table 11.5.2-2: Minimum performance

Test num.	Bandwidth	discSupportedProc	Number of configured resource pools	$\hat{E}_s$ at antenna port (dBm/15kHz)	Reference value
					Fraction of maximum throughput (%) for Sidelink UE $i=0\dots\text{discSupportedProc}-1$
1	5 MHz	50	5	-85	95
2	10 MHz	50	2	-85	95
3	15 MHz	50	2	-85	95
4	20 MHz	50	1	-85	95
5	10 MHz	400	16	-85	95
6	15 MHz	400	11	-85	95
7	20 MHz	400	8	-85	95

## 12 Performance requirement (ProSe Direct Communication)

This clause contains the performance requirements for the Sidelink physical channels specified for ProSe Direct Communication in TS 36.211 [4].

### 12.1 General

#### 12.1.1 Applicability of requirements

##### 12.1.1.1 Applicability of requirements for different channel bandwidths

The requirements in this clause are applicable to UEs that support ProSe Direct Communication. Test cases defined for 5MHz channel bandwidth are applicable to UEs that support ProSe Direct Communication on only Band 31.

##### 12.1.1.2 Test coverage for different number of component carriers

For FDD tests specified in 12.8, if corresponding CA tests are tested, the test coverage can be considered fulfilled without executing single carrier tests.

##### 12.1.1.3 Applicability and test rules for different CA configurations and bandwidth combination sets

The performance requirement for CA UE demodulation tests with active Sidelink in Clause 12 are defined independent of CA configurations and bandwidth combination sets specified in Clause 5.6A.1. For UEs supporting different CA configurations and bandwidth combination sets, the applicability and test rules are defined in Table 12.1.1.3-1. For simplicity, CA configuration below refers to combination of CA configuration and bandwidth combination set.

Table 12.1.1.3-1: Applicability and test rules for CA UE demodulation tests with active Sidelink

Tests	CA capability where the tests apply	CA configuration from the selected CA capability where the tests apply	CA Bandwidth combination to be tested in priority order
CA tests with 2CCs in Clause 12.8	Any one of the supported CA capabilities with largest aggregated CA bandwidth combination	Any one of the supported FDD CA configurations with largest aggregated CA bandwidth combination	Largest aggregated CA bandwidth combination

## 12.1.2 Reference DRX configuration

**Table 12.1.2-1: Reference DRX configuration**

Parameter	Value	Comments
onDurationTimer	psf1	
drx-InactivityTimer	psf1	
drx-RetransmissionTimer	psf1	
longDRX-CycleStartOffset	sf2560, 0	
shortDRX	disabled	
NOTE 1: For further information see clause 6.3.2 in TS 36.331.		

## 12.2 Demodulation of PSSCH

The purpose of the requirements in this subclause is to verify the PSSCH demodulation performance with a single active PSSCH link.

### 12.2.1 FDD

The minimum requirements are specified in Table 12.2.1-2 with the test parameters specified in Table 12.2.1-1. This test specifies an out-of-coverage scenario where Sidelink UE 1 is the synchronization reference only and Sidelink UE 2 transmits PSCCH and PSSCH.



Table 12.2.1-1: Test Parameters

Parameter		Unit	Test 1	
Communication resource pool configuration			As specified in Table A.7.2.1-1 (Configuration #1-FDD)	
$N_{oc}$ at antenna port (NOTE 1)		dBm/15 kHz	-98	
Active cell(s)			None	
Sidelink UE 1	Sidelink Transmissions		SLSS + PSBCH	
	networkControlledSyncTx		ON	
	slssid		30	
	inCoverage (in MIB-SL)		FALSE	
	syncOffsetIndicator		Set same as syncOffsetIndicator1 in Configuration #1-FDD	
	Propagation channel		EPA5	
	Antenna configuration		1x2 Low	
$E_s$ at antenna port	dBm/15 kHz		-85	
Sidelink UE 2	Sidelink Transmissions		PSCCH + PSSCH	
	PSCCH RMC		5MHz: CC.3 FDD 10 MHz: CC.4 FDD	
	PSCCH subframe allocation		As defined by TS 36.213 with $n_{PSCCH}$ chosen randomly (uniformly) in $[0, M_{RB}^{PSCCH} - RP / 2]_{L_{PSCCH} - 1}$ every sc-period	
	PSCCH RB allocation			
	$E_s$ of PSCCH at antenna port	dBm/15 kHz		-85
	PSSCH RMC		As specified in Table 12.2.1-2	
	PSSCH subframe allocation		As per time repetition pattern specified in PSCCH	
	PSSCH RB allocation		First transmission: Chosen randomly (uniformly) among the allowed RBs as per TS36.213 HARQ retransmission: As per frequency hopping indicated in PSCCH and specified in TS36.213	
	Time offset (NOTE 2)	$\mu$ s		+1
	Frequency offset (NOTE 3)	Hz		+200
Propagation Channel			EVA70	
Antenna configuration			1x2 Low	
NOTE 1: Applicable to both DL channel and ProSe Direct Communication Subframes on UL.				
NOTE 2: Time offset of Sidelink UE 2 receive signal timing with respect to Sidelink UE 1 receive signal timing at the tested UE.				
NOTE 3: Frequency offset of Sidelink UE 2 with respect to Sidelink UE 1 transmit frequency.				

Table 12.2.1-2: Minimum performance

Test num.	Sidelink UE	Bandwidth	PSSCH Reference channel	Reference value	
				Fraction of maximum throughput (%) (NOTE 1)	SNR (dB) of PSSCH
1	2	10 MHz	CD.1 FDD	70	-3.4
		5 MHz		70	-3.3
NOTE 1: The throughput is measured after 40 radio frames of lead time during which the test UE detects and synchronizes to Sidelink UE 1.					

## 12.3 Demodulation of PSCCH

The purpose of the requirements in this subclause is to verify the PSCCH demodulation performance with a single active PSSCH link.

## 12.3.1 FDD

The minimum requirements are specified in Table 12.3.1-2 with the test parameters specified in Table 12.3.1-1. This test specifies an out-of-coverage scenario where Sidelink UE 1 is the synchronization reference only and Sidelink UE 2 transmits PSCCH and PSSCH.

**Table 12.3.1-1: Test Parameters**

Parameter		Unit	Test 1
Communication resource pool configuration			As specified in Table A.7.2.1-1 (Configuration #1-FDD)
$N_{oc}$ at antenna port (NOTE 1)		dBm/15 kHz	-98
Active cell(s)			None
Sidelink UE 1	Sidelink Transmissions		SLSS + PSBCH
	networkControlledSyncTx		ON
	sIssid		30
	inCoverage (in MIB-SL)		FALSE
	syncOffsetIndicator		Set same as syncOffsetIndicator1 in Configuration #1-FDD
	Propagation channel		EPA5
	Antenna configuration		1x2 Low
$E_s$ at antenna port	dBm/15 kHz		-85
Sidelink UE 2	Sidelink Transmissions		PSCCH + PSSCH
	PSCCH RMC		As specified in Table 12.3.1-2
	PSCCH subframe allocation		As defined by TS 36.213 with $n_{PSCCH}$ chosen randomly (uniformly) in $[0, M_{RB}^{PSCCH} - RP / 2 \lfloor L_{PSCCH} - 1 \rfloor]$ every sc-period
	PSCCH RB allocation		CD.1 FDD
	PSSCH RMC		As per time repetition pattern specified in PSCCH
	PSSCH subframe allocation		As per time repetition pattern specified in PSCCH
	PSSCH RB allocation		First transmission: Chosen randomly (uniformly) among the allowed RBs as per TS36.213 HARQ retransmission: As per frequency hopping indicated in PSCCH and specified in TS36.213
	Time offset (NOTE 2)	$\mu$ s	+1
	Frequency offset (NOTE 3)	Hz	+200
	Propagation Channel		EVA70
Antenna configuration		1x2 Low	
NOTE 1: Applicable to both DL channel and ProSe Direct Communication Subframes on UL.			
NOTE 2: Time offset of Sidelink UE 2 receive signal timing with respect to Sidelink UE 1 receive signal timing at the tested UE.			
NOTE 3: Frequency offset of Sidelink UE 2 with respect to Sidelink UE 1 transmit frequency.			

**Table 12.3.1-2: Minimum performance**

Test num.	Sidelink UE	Band-width	PSCCH Reference channel	Reference value	
				Probability of missed PSCCH (%) (NOTE 1)	SNR (dB) of PSCCH
1	2	10 MHz	CC.4 FDD	1	4.7
		5 MHz	CC.3 FDD	1	4.8
NOTE 1: The probability is measured after 40 radio frames of lead time during which the test UE detects and synchronizes to Sidelink UE 1.					

## 12.4 Demodulation of PSBCH

The purpose of the requirements in this subclause is to verify the PSBCH demodulation performance with a single active link.

### 12.4.1 FDD

The minimum requirements are specified in Table 12.4.1-2 with the test parameters specified in Table 12.4.1-1.

**Table 12.4.1-1: Test Parameters**

Parameter		Unit	Test 1
Communication resource pool configuration			As specified in Table A.7.2.1-1 (Configuration #1-FDD)
$N_{oc}$ at antenna port		dBm/15kHz	-98
Active cell(s)			None
Sidelink UE 1	Sidelink Transmissions		SLSS + PSBCH (CP.1 FDD)
	networkControlledSyncTx		ON
	slsid		30
	inCoverage (in MIB-SL)		FALSE
	syncOffsetIndicator		Set same as syncOffsetIndicator1 in Configuration #1-FDD
	Propagation channel		EPA5
	Antenna configuration		1x2 Low

**Table 12.4.1-2: Minimum performance**

Test num.	Sidelink UE	Bandwidth	Reference channel	Reference value	
				Probability of missed PSBCH (%) (NOTE 1)	SNR (dB)
1	1	10 MHz	PSBCH (CP.1 FDD)	1	4.4
		5 MHz			
NOTE 1: The probability is measured after 40 radio frames of lead time during which the test UE detects and synchronizes to Sidelink UE 1.					

## 12.5 Power imbalance performance with two links

The purpose of this test is to check the demodulation performance when receiving PSSCH transmissions from two Sidelink UEs with power imbalance in one subframe.

### 12.5.1 FDD

The test parameters in Table 12.5.1-1 specifies an in-coverage scenario where Sidelink UE 1 and 2 are synchronized to Cell 1 and transmit PSSCH on adjacent RBs. The minimum requirements are specified in Table 12.5.1-2.

Table 12.5.1-1: Test Parameters

Parameter		Unit	Test 1	
Communication resource pool configuration			As specified in Table A.7.2.1-2 (Configuration #2-FDD)	
DRX configuration			As specified in Table 12.1.2-1	
$N_{oc}$ at antenna port (Note 3)		dBm/15kHz	-98	
Active cell(s)			Cell 1 (Serving cell)	
Cell 1	Cyclic prefix		Normal	
	Cell ID		0	
	Downlink power allocation	$\rho_A$	dB	0
		$\rho_B$	dB	0 (NOTE 1)
		$\sigma$	dB	0
	OCNG Pattern (Note 2)		OP.1 FDD	
	Propagation channel		AWGN	
Antenna configuration		1x2		
RSRP	dBm/15kHz	-92		
Active Sidelink UE(s)			Sidelink UE 1, Sidelink UE 2	
Sidelink UE 1	Sidelink Transmissions		PSCCH + PSSCH	
	PSCCH RMC		5 MHz: CC.1 FDD 10 MHz: CC.2 FDD	
	PSCCH subframe allocation		$n_{PSCCH} = 0$ (as defined in TS 36.213)	
	PSCCH RB allocation			
	$E_s$ of PSCCH at antenna port	dBm/15kHz	-85	
	PSSCH RMC		As specified in Table 12.5.1-2	
	PSSCH subframe allocation		As per time repetition pattern specified in PSCCH	
	PSSCH RB allocation		PRB pairs {4, 5}	
	Time offset (NOTE 4)	$\mu$ s	0	
	Frequency offset (NOTE 5)	Hz	0	
	Propagation Channel		AWGN	
	Antenna configuration		1x2	
	Sidelink UE 2	Sidelink Transmissions		PSCCH + PSSCH
PSCCH RMC			5 MHz: CC.1 FDD 10 MHz: CC.2 FDD	
PSCCH subframe allocation			$n_{PSCCH} = 2$ (as defined in TS 36.213)	
PSCCH RB allocation				
$E_s$ of PSCCH at antenna port		dBm/15kHz	-85	
PSSCH RMC			As specified in Table 12.5.1-2	
PSSCH subframe allocation			As per time repetition pattern specified in PSCCH	
PSSCH RB allocation			PRB pairs {6, 7}	
Time offset (NOTE 4)		$\mu$ s	0	
Frequency offset (NOTE 5)		Hz	0	
Propagation Channel			AWGN	
Antenna configuration			1x2	
NOTE 1: $P_B = 0$ .				
NOTE 2: OCNG is used to fully allocate the available resource blocks to virtual UEs.				
NOTE 3: Applicable to both DL channel and ProSe Direct Communication Subframes on UL.				
NOTE 4: The power of PSCCH is set high to ensure reliable reception of PSCCH.				
NOTE 5: Time offset of Sidelink UE receive signal with respect to Cell 1 downlink timing at the tested UE.				
NOTE 6: Frequency offset of Sidelink UE with respect to Cell 1 uplink frequency.				

**Table 12.5.1-2: Minimum performance**

Test num.	Bandwidth	Sidelink UE	PSSCH Reference channel	Reference value	
				Fraction of maximum throughput (%)	SNR (dB) of PSSCH
1	5 / 10 MHz	1	CD.5 FDD	(NOTE 1)	24.35
		2	CD.5 FDD	70	2.4

NOTE 1: There is no throughput requirement for Sidelink UE 1.

## 12.6 Multiple timing reference test

The purpose of this test is to check the PSSCH demodulation performance when receiving from two Sidelink UEs that follow different timing references and transmitting on different resources (non-overlapping in time).

### 12.6.1 FDD

The test parameters are specified in Table 12.6.1-1. Sidelink UE 2 and the receiver UE under test are associated with Cell 1. Sidelink UE 1 and Sidelink UE 3 are associated with another cell and use a different timing, and Sidelink UE 1 acts as a synchronization reference only. The minimum requirements are specified in Table 12.6.1-2.

**Table 12.6.1-1: Test Parameters**

Parameter		Unit	Test 1	
Communication resource pool configuration			As specified in Table A.7.2.1-3 (Configuration #3-FDD)	
DRX configuration			As specified in Table 12.1.2-1	
$N_{oc}$ at antenna port (Note 3)		dBm/15kHz	-98	
Active cell(s)			Cell 1 (Serving cell)	
Cell 1	Cyclic prefix		Normal	
	Cell ID		0	
	Downlink power allocation	$\rho_A$	dB	0
		$\rho_B$	dB	0 (NOTE 1)
		$\sigma$	dB	0
	OCNG Pattern <sup>NOTE 2</sup>		OP.1 FDD	
	Propagation channel		AWGN	
	Antenna configuration		1x2	
RSRP	dBm/15kHz	-92		
Active Sidelink UE(s)			Sidelink UE 1, Sidelink UE 2, Sidelink UE 3	
Sidelink UE 1	Sidelink Transmissions		SLSS + PSBCH	
	networkControlledSyncTx		ON	
	slssid		30	
	inCoverage (in MIB-SL)		TRUE	
	syncOffsetIndicator		Set same as syncOffsetIndicator in Configuration #3-FDD	
	Time offset (NOTE 5)	ms	+12.51 ms	
	Frequency offset (NOTE 6)	Hz	-100 Hz	
	Propagation channel		EPA5	
	Antenna configuration		1x2 Low	
	$E_s$ at antenna port	dBm/15kHz	-85	
Sidelink UE 2	Sidelink Transmissions		PSCCH + PSSCH	
	Resource pool		<i>commRxPool(0)</i>	
	PSCCH RMC		5MHz: CC.1 FDD 10 MHz: CC.2 FDD (NOTE 5)	
	PSCCH subframe allocation		As defined by TS 36.213 with $n_{PSCCH}$ chosen randomly (uniformly) in	
	PSCCH RB allocation		$[0, M_{RB}^{PSCCH} - RP / 2 \lfloor L_{PSCCH} - 1 \rfloor]$ every sc-period	
	$E_s$ of PSCCH at antenna port	dBm/15kHz	-85	
	PSSCH RMC		As specified in Table 12.6.1-2	
	PSSCH subframe allocation		As per time repetition pattern specified in PSCCH	
	PSSCH RB allocation		First transmission: Chosen randomly (uniformly) among the allowed RBs as per TS36.213 HARQ retransmission: As per frequency hopping indicated in PSCCH and specified in TS36.213	
	Time offset (NOTE 4, 5)		PSCCH: +1 $\mu$ s PSSCH: +1 $\mu$ s – 288T <sub>s</sub>	
	Frequency offset (NOTE 6)	Hz	+200	
Propagation Channel		EVA70		
Antenna configuration		1x2 Low		
Sidelink UE 3	Sidelink Transmissions		PSCCH + PSSCH	
	Resource pool		<i>commRxPool(1)</i>	
	PSCCH RMC		5MHz: CC.5 FDD 10 MHz: CC.6 FDD	
	PSCCH subframe allocation		As defined by TS 36.213 with $n_{PSCCH}$ chosen randomly (uniformly) in	
	PSCCH RB allocation		$[0, M_{RB}^{PSCCH} - RP / 2 \lfloor L_{PSCCH} - 1 \rfloor]$ every sc-period	
	$E_s$ of PSCCH at antenna port	dBm/15kHz	-85	
	PSSCH RMC		As specified in Table 12.6.1-2	
	PSSCH subframe allocation		As per time repetition pattern specified in PSCCH	

	PSSCH RB allocation		First transmission: Chosen randomly (uniformly) among the allowed RBs as per TS36.213 HARQ retransmission: As per frequency hopping indicated in PSCCH and specified in TS36.213
	Time offset (NOTE 5)	ms	+12.509
	Frequency offset (NOTE 6)	Hz	+300
	Propagation Channel		EVA70
	Antenna configuration		1x2 Low
NOTE 1: $P_B = 0$ .			
NOTE 2: OCNG is used to fully allocate the available resource blocks to virtual UEs.			
NOTE 3: Applicable to both DL channel and ProSe Direct Communication Subframes on UL.			
NOTE 4: Timing advance indication in PSSCH is set as 18 ( $=288T_s$ ) in this test. PSSCH timing is advanced with respect to PSCCH timing by the quantity (i.e., PSSCH timing shall be $+1\mu s - 288T_s$ in this test).			
NOTE 5: Time offset of Sidelink UE receive signal with respect to Cell 1 downlink timing at the tested UE.			
NOTE 6: Frequency offset of Sidelink UE with respect to Cell 1 uplink frequency.			

Table 12.6.1-2: Minimum performance

Test num.	Bandwidth	Sidelink UE	PSSCH Reference channel	Reference value	
				Fraction of maximum throughput (%) (NOTE 1)	SNR (dB)
1	10 MHz	2	CD.4 FDD	70	3.0
		3	CD.2 FDD	70	2.8
	5 MHz	2	CD.3 FDD	70	2.9
		3	CD.2 FDD	70	2.8
NOTE 1: The throughput is measured after 40 radio frames of lead time during which the test UE detects and synchronizes to Sidelink UE 1.					

## 12.7 Maximum Sidelink processes test

The purpose of this test is to verify the maximum number of Sidelink processes and the maximum number of bits per TTI supported by the UE.

### 12.7.1 FDD

The test parameters are specified in Table 12.7.1-1. Multiple communication resource pools are interleaved. Each active Sidelink UE transmits in one of the resource pools with 3 retransmissions. The minimum requirements are specified in Table 12.7.1-2.



Table 12.7.1-1: Test Parameters

Parameter		Unit	Test 1	
Communication resource pool configuration			As specified in Table A.7.2.1-4 (Configuration #4-FDD)	
DRX configuration			As specified in Table 12.1.2-1	
Active cell(s)			Cell 1 (Serving cell)	
Cell 1	Cyclic prefix		Normal	
	Cell ID		0	
	Downlink power allocation	$\rho_A$	dB	0
		$\rho_B$	dB	0 (NOTE 1)
		$\sigma$	dB	0
	OCNG Pattern (Note 2)		OP.1 FDD	
	Propagation channel		Static propagation condition No external noise sources are applied	
Antenna configuration		1x2		
RSRP	dBm/15kHz		-85	
Active Sidelink UE(s)			Sidelink UE $i$ , $0 \leq i \leq 15$	
Sidelink UE $i$ , $0 \leq i \leq 15$	Sidelink Transmissions		PSCCH + PSSCH	
	Resource pool		$commRxPool\left(\frac{i}{8}\right)$	
	PSCCH RMC		5MHz: CC.1 FDD with $l_{TRP}=i\%8$ (NOTE 3) 10 MHz: CC.2 FDD with $l_{TRP}=i\%8$ (NOTE 3)	
	PSCCH subframe allocation		As defined by TS 36.213 with $n_{PSCCH} = i$	
	PSCCH RB allocation			
	PSSCH RMC		As specified in Table 12.7.1-2	
	PSSCH subframe allocation		As per time repetition pattern specified in PSCCH	
	PSSCH RB allocation		Fully allocated	
	Time offset (NOTE 4)	$\mu s$		0
	Frequency offset (NOTE 5)	Hz		0
	Propagation Channel		Static propagation condition No external noise sources are applied	
Antenna configuration		1x2 Low		
NOTE 1: $P_B = 0$ .				
NOTE 2: OCNG is used to fully allocate the available resource blocks to virtual UEs.				
NOTE 3: For $N_{TRP} = 8$ (FDD) and $trpt-Subset = 001$ , $l_{TRP} = 0$ corresponds to a time repetition pattern of (1,0,0,0,0,0,0,0), $l_{TRP} = 1$ corresponds to a time repetition pattern of (0,1,0,0,0,0,0,0), etc.				
NOTE 4: Time offset of Sidelink UE receive signal with respect to Cell 1 downlink timing at the tested UE.				
NOTE 5: Frequency offset of Sidelink UE with respect to Cell 1 uplink frequency.				

Table 12.7.1-2: Minimum performance

Test num.	Bandwidth	PSCCH Reference channel	$\hat{E}_s$ at antenna port (dBm/15kHz)	Reference value for Sidelink UE $i=0\dots15$
				Fraction of maximum throughput (%)
1	10 MHz	CD.7 FDD	-85	95
	5 MHz	CD.6 FDD	-85	95

## 12.8 Sustained downlink data rate with active Sidelink

The purpose of this test is to verify the downlink data rate is not impacted when Sidelink resource are also configured. The test parameters are in Table 12.8.1-1. Cell 1 is the serving cell and UE 1 and UE 2 are transmitters of Prose Direct Communication. The test UE is expected to receive all PDSCH transmissions, and prioritize the transmission of ACK/NACK over the reception of UE 2's PSSCH.

The test cases apply to UE categories and bandwidth combinations with maximum aggregated bandwidth as specified in Table 12.8.1-2. The minimum requirements are specified in Table 12.8.1-3. The TB success rate in the cellular link shall be sustained during at least 300 frames.

**Table 12.8.1-1: Test parameters for sustained downlink data rate (FDD 64QAM) with active Sidelink**

Parameter		Unit	Test 1, 2, 3A, 3B, 4A, 6C
Communication resource pool configuration <sup>Note 5</sup>			As specified in Table A.7.2.1-5 (Configuration #5-FDD)
Active cell(s)			Cell 1 (PCell) Cell 2 (SCell) for Test 3B, 4A, 6C
Cell 1	Test parameters		As specified in clause 8.7.1: Table 8.7.1-1 and Test 1, 2, 3A, 3B, 4A, 6C in Table 8.7.1-2
Active Sidelink UE(s)			Sidelink UE 1, Sidelink UE 2
Sidelink UE 1	Sidelink Transmissions		PSCCH + PSSCH
	PSCCH RMC		10 MHz: CC.2 FDD with $I_{TRP}=0$ (NOTE 1)
	PSCCH subframe allocation		As defined by TS 36.213 with $n_{PSCCH} = 0$
	PSCCH RB allocation		
	PSSCH RMC		10 MHz: CD.7 FDD
	PSSCH subframe allocation		As per time repetition pattern specified in PSCCH
	PSSCH RB allocation		Fully allocated
	Time offset (NOTE 3)	μs	0
	Frequency offset (NOTE 4)	Hz	0
	Propagation Channel		Static propagation condition No external noise sources are applied
Antenna configuration		1x2 Low	
$E_s$ at antenna port	dBm/15kHz		-85
Sidelink UE 2	Sidelink Transmissions		PSCCH (NOTE 2)
	PSCCH RMC		10 MHz: CC.2 FDD with $I_{TRP}=1$ (NOTE 1)
	PSCCH subframe allocation		As defined by TS 36.213 with $n_{PSCCH} = 1$
	PSCCH RB allocation		
	Time offset (NOTE 3)	μs	0
	Frequency offset (NOTE 4)	Hz	0
	Propagation Channel		Static propagation condition No external noise sources are applied
	Antenna configuration		1x2 Low
$E_s$ at antenna port	dBm/15kHz		-85
NOTE 1: For $N_{TRP} = 8$ (FDD) and $trpt-Subset = 001$ , $I_{TRP} = 0$ corresponds to a time repetition pattern of (1,0,0,0,0,0,0,0), $I_{TRP} = 1$ corresponds to a time repetition pattern of (0,1,0,0,0,0,0,0).			
NOTE 2: Sidelink UE 2 transmits PSCCH but not PSSCH.			
NOTE 3: Time offset of Sidelink UE receive signal with respect to Cell 1 downlink timing at the tested UE.			
NOTE 4: Frequency offset of Sidelink UE with respect to Cell 1 uplink frequency.			
NOTE 5: Sidelink Communication resources are configured on the primary serving cell.			

**Table 12.8.1-2: Test cases for sustained data rate**

CA config	Maximum supported Bandwidth/ Bandwidth combination (MHz)	Cat. 1	Cat. 2	Cat. 3	Cat. 4	Cat. 6,7	Cat. 9,10	Cat 11, 12	DL Cat. 15
								DL Cat. 11,12	
Single carrier	10	1	2	3A	3A	3A	3A	3A	3A
CA with 2CCs (Note1)	10+10	-	-	3B	4A	4A	4A	4A	4A
	10+20	-	-	3B	4A	6C	6C	6C	6C
NOTE 1: Sidelink operation is configured on PCC									

Table 12.8.1-3: Minimum requirements (FDD 64QAM) with active Sidelink

Test	Bandwidth (MHz)	Number of bits of a DL-SCH transport block received within a TTI	Measurement channel	Reference value
				PDSCH TB success rate (%)
1	10	10296	R.31-1 FDD (NOTE 2)	95
2	10	25456	R.31-2 FDD (NOTE 2)	95
3A	10	36696 (NOTE 1)	R.31-3A FDD (NOTE 2)	85
3B	10+10	25456	R.31-2 FDD (NOTE 2)	95
4A	10+10	75376 (NOTE 3)	R.31-4 FDD (NOTE 2)	85
6C	10+20	36696 (NOTE 1) for 10MHz CC 75376 (NOTE 3) for 20MHz CC	R.31-3A FDD for 10MHz CC R.31-4 FDD for 20MHz CC	85

NOTE 1: 35160 bits for sub-frame 5.  
NOTE 2: PDSCH scheduling pattern is changed as per the following bitmap that repeats every 40ms, and applies to all the serving cells.  
PDSCH scheduling subframe bitmap = {01110111 11110111 11110111 11110111 11111110}.

NOTE 3: 71112 bits for sub-frame 5.

## 13 Void

## 14 Performance requirement (V2X Sidelink Communication)

This clause contains the performance requirements for the sidelink physical channels specified for V2X Sidelink Communication.

### 14.1 General

#### 14.1.1 Applicability of requirements

The requirements in this clause are applicable to UEs that support V2X sidelink communication using Band 47.

When GNSS or GNSS-equivalent synchronization source is used, the reference GNSS signal power is as specified in Table B.6.1-1 in TS 36.133.

The test case applicability is in according to Table 14.1.1-1.

Table 14.1.1-1: V2X test applicability

Tests / clause	Applicable if UE supports the following capability
14.2 14.3 14.4 14.8 Test 1	UE supporting V2X sidelink If the SL-C-RX Category 4 UE passes 14.11 Test 1 or 2, then the test coverage can be considered fulfilled without executing 14.8 Test 1.
14.5	UE with support of <i>slss-TxRx-r14</i> [7]
14.6 14.9	UE supporting concurrent operation band for V2X and E-UTRA
14.7	UE not supporting concurrent operation band for V2X and E-UTRA
14.8 Test 2	UE with support of <i>v2x-HighReception-r14</i> [7]. If the SL-C-RX Category 4 UE passes 14.11 Test 3 or 4, then the test coverage can be considered fulfilled without executing 14.8 Test 2.
14.10 Test 1 14.11 Test 1	UE with support of CA with 2 SL CCs and without support of CA with 3 SL CCs
14.10 Test 2 14.11 Test 2	UE with support of CA with 3 SL CCs
14.11 Test 3	UE with support of <i>v2x-EnhancedHighReception-r15</i> [7] and CA with 2 SL CCs and without support of CA with 3 SL CCs
14.11 Test 4	UE with support of <i>v2x-EnhancedHighReception-r15</i> [7] and CA with 3 SL CCs

## 14.2 Demodulation of PSSCH

The purpose of the requirements in this subclause is to verify the PSSCH for V2X demodulation performance with a single active PSSCH link.

The minimum requirements are specified in Table 14.2-2 with the test parameters specified in Table 14.2-1. In this test scenario, GNSS or GNSS-equivalent synchronization source is used and Sidelink UE 1 transmits PSSCH and PSSCH.

Table 14.2-1: Test Parameters

Parameter	Unit	Test 1, 2	Test 3, 4	
Communication resource pool configuration		As specified in Table A.9-1 (Configuration #1-V2X)		
$N_{oc}$ at antenna port	dBm/15 kHz	-98		
Active cell(s)		None		
V2X Tx format (SL-V2X-TxProfileList-r15)		N/A	SL-V2X-TxProfile-r15 = rel15	
Sidelink UE 1	Sidelink Transmissions	PSSCH+PSSCH		
	Timing offset (Note 1)	CP/2-12Ts		
	Frequency offset (Note 2)	Hz	+600	
	Synchronization	GNSS or GNSS-equivalent		
	Antenna configuration	1x2 Low		
Note 1:	Time offset of Sidelink UE receive signal with respect to GNSS reference timing.			
Note 2:	Frequency offset of Sidelink UE with respect to GNSS reference frequency.			

Table 14.2-2: Minimum performance

Test num.	Bandwidth	PSSCH Reference channel	Propagation condition	Reference value	
				PSSCH BLER (%)	SNR (dB) of PSSCH
1	20 MHz	CD.8	EVA180	10	14.2
2	10 MHz	CD.9	EVA2700		5.4
3	20 MHz	CD.13	EVA180		12.5
4	10 MHz	CD.14	EVA2700		2.8

## 14.3 Demodulation of PSCCH

The purpose of the requirements in this subclause is to verify the PSCCH for V2X demodulation performance with a single active PSSCH link.

The minimum requirements are specified in Table 14.3-2 with the test parameters specified in Table 14.3-1. In this test scenario, GNSS or GNSS-equivalent synchronization source is used and Sidelink UE 1 transmits PSCCH and PSSCH.

**Table 14.3-1: Test Parameters**

Parameter		Unit	Test 1
Communication resource pool configuration			As specified in Table A.9-1 (Configuration #1-V2X)
$N_{oc}$ at antenna port		dBm/15 kHz	-98
Active cell(s)			None
Sidelink UE 1	Sidelink Transmissions		PSCCH+PSSCH
	Timing offset (Note 1)		CP/2-12Ts
	Frequency offset (Note 2)	Hz	+600
	Synchronization		GNSS or GNSS-equivalent
	Antenna configuration		1x2 Low
PSSCH RMC			CD.9
Note 1: Time offset of Sidelink UE receive signal with respect to GNSS reference timing.			
Note 2: Frequency offset of Sidelink UE with respect to GNSS reference frequency.			
Note 3: Cyclic shift for PSCCH DMRS is randomly selected between {0, 3, 6, 9} for each PSCCH transmission.			

**Table 14.3-2: Minimum performance**

Test number	Bandwidth	PSCCH Reference channel	Propagation condition	Reference value	
				Probability of missed PSCCH (%)	SNR (dB) of PSCCH
1	10 MHz	CC.8	EVA1500	1	2.6

## 14.4 Power imbalance performance with two links

The purpose of this test is to check the demodulation performance when receiving PSSCH transmissions from two Sidelink UEs with power imbalance in one subframe.

The minimum requirements are specified in Table 14.4-2 with the test parameters specified in Table 14.4-1. The Sidelink UE 1 and 2 are synchronized to GNSS or GNSS-equivalent synchronization reference.

Table 14.4-1: Test Parameters

Parameter	Unit	Test 1	
Communication resource pool configuration		As specified in Table A.9-2 (Configuration #2-V2X)	
$N_{oc}$ at antenna port	dBm/15kHz	-98	
Active cell(s)		None	
Active Sidelink UE(s)		Sidelink UE 1, Sidelink UE 2	
Sidelink UE 1	Sidelink Transmissions	PSCCH + PSSCH	
	PSCCH RB allocation	PRB pairs {5, 6}	
	PSSCH RMC	As specified in Table 14.4-2	
	PSSCH RB allocation	PRB pairs {7, 8, 9}	
	Time offset (Note 1)	$\mu$ s	0
	Frequency offset (Note 2)	Hz	0
	Propagation Channel		AWGN
	Antenna configuration		1x2
Sidelink UE 2	Sidelink Transmissions	PSCCH + PSSCH	
	PSCCH RB allocation	PRB pairs {20, 21}	
	PSSCH RMC	As specified in Table 14.4-2	
	PSSCH RB allocation	PRB pairs {22, 23, 24}	
	Time offset (Note 1)	$\mu$ s	0
	Frequency offset (Note 2)	Hz	0
	Propagation Channel		AWGN
	Antenna configuration		1x2
Note 1: Time offset of Sidelink UE receive signal with respect to GNSS reference timing.			
Note 2: Frequency offset of Sidelink UE with respect to GNSS reference frequency.			

Table 14.4-2: Minimum performance

Test number	Bandwidth	Sidelink UE	PSSCH Reference channel	Reference value	
				PSSCH BLER (%)	SNR (dB) of PSSCH
1	20MHz	1	CD.10	(Note 1)	30.35
		2	CD.10	10	13.3
Note 1: There is no throughput requirement for Sidelink UE 1.					

## 14.5 Demodulation of PSBCH

The purpose of the requirements in this subclause is to verify the PSBCH demodulation performance with a single active link.

The minimum requirements are specified in Table 14.5-2 with the test parameters specified in Table 14.5-1. The Sidelink UE 1 is synchronized to SLSS as synchronization reference.

Table 14.5-1: Test Parameters

Parameter	Unit	Test 1	
Communication resource pool configuration		As specified in Table A.9-1 (Configuration #1-V2X)	
$N_{oc}$ at antenna port	dBm/15kHz	-98	
Active cell(s)		None	
Sidelink UE 1	Sidelink Transmissions	SLSS+PSBCH (Note 3)	
	slssid	169	
	Time offset (Note 1)	$\mu$ s	0
	Frequency offset (Note 2)	Hz	0
	Synchronization source		SLSS
	Antenna configuration		1x2 Low
Note 1: Time offset of Sidelink UE receive signal with respect to GNSS reference timing.			
Note 2: Frequency offset of Sidelink UE with respect to GNSS reference frequency.			
Note 3: PSBCH transmits together with corresponding SLSS in the same subframe.			

Table 14.5-2: Minimum performance

Test number	Bandwidth	PSBCH Reference channel	Propagation condition	Reference value	
				Probability of missed PSBCH (%)	SNR (dB) of PSBCH
1	20 MHz	CP.2	EVA180	1	2.5

## 14.6 Demodulation of PSSCH with eNB based synchronization

The purpose of the requirements in this subclause is to verify the PSSCH for V2X demodulation performance with a single active PSSCH link under eNB based synchronization.

The minimum requirement is specified in Table 14.6-2 with the test parameters specified in Table 14.6-1. In this test scenario, eNB based synchronization source is used and Sidelink UE 1 transmits PSCCH and PSSCH.

Table 14.6-1: Test Parameters

Parameter		Unit	Test 1	
Communication resource pool configuration			As specified in Table A.9-3 (Configuration #3-V2X)	
$N_{oc}$ at antenna port		dBm/15 kHz	-98	
Active cell(s)			Cell 1 (Serving cell)	
Cell 1	Cyclic prefix		Normal	
	Cell ID		0	
	Downlink power allocation	$\rho_A$	dB	0
		$\rho_B$	dB	0 (Note 1)
		$\sigma$	dB	0
	OCNG Pattern (Note 2)			OP.1 FDD
	Propagation channel			AWGN
	Antenna configuration			1x2 Low
RSRP		dBm/15 kHz	-92	
Sidelink UE 1	Sidelink Transmissions		PSCCH+PSSCH	
	Timing offset (Note 3)		CP/2-24Ts	
	Frequency offset (Note 4)	Hz	+1300	
	Synchronization source		Cell 1	
	Antenna configuration		1x2 Low	
Note 1: $P_B = 0$ .				
Note 2: OCNG is used to fully allocate the available resource blocks to virtual UEs.				
Note 3: Time offset of Sidelink UE receive signal with respect to Cell1 reference timing.				
Note 4: Frequency offset of Sidelink UE with respect to Cell 1 reference frequency.				

Table 14.6-2: Minimum performance

Test num.	Bandwidth	PSSCH Reference channel	Propagation condition	Reference value	
				PSSCH BLER (%)	SNR (dB) of PSSCH
1	20 MHz	CD.12	EVA180	10	4.9

## 14.7 Soft buffer test

The purpose of this test is to verify the maximum number of bits per TTI supported by the V2X UE.

The minimum requirement is specified in Table 14.7-2 with the test parameters specified in Table 14.7-1.

**Table 14.7-1: Test Parameters**

Parameter	Unit	Test 1	Test 2
Communication resource pool configuration		As specified in Table A.9-4 (Configuration #4-V2X)	
$N_{oc}$ at antenna port	dBm/15kHz	-98	
Active cell(s)		None	
V2X Tx format (SL-V2X-TxProfileList-r15)		N/A	SL-V2X-TxProfile-r15 = rel15
Active Sidelink UE(s)		Sidelink UE $i$ , $0 \leq i \leq 14$	
Sidelink UE $i$ , $0 \leq i \leq 14$	Sidelink Transmissions	PSCCH + PSSCH	
	Time gap between initial transmission and retransmission	Subframe	15
	Timing offset (Note 1)	$\mu$ s	0
	Frequency offset (Note 2)	Hz	0
	Synchronization source	GNSS or GNSS-equivalent	
Antenna configuration		1x2	
Note 1:	Time offset of Sidelink UE receive signal with respect to GNSS reference timing.		
Note 2:	Frequency offset of Sidelink UE with respect to GNSS reference frequency.		
Note 3:	15 sidelink UEs should transmit one by one circularly for every subframe.		

**Table 14.7-2: Minimum performance**

Test num.	Bandwidth	PSSCH Reference channel	Propagation condition	Reference value		ue- CategorySL- C-RX
				PSSCH BLER (%)	SNR (dB) of PSSCH	
1	20 MHz	CD.11	AWGN	5	8.0	SL-C-RX Category 2
2	20 MHz	CD.15	AWGN	5	12.0	SL-C-RX Category 3

## 14.8 PSCCH/PSSCH decoding capability test

The purpose of this test is to verify the maximum number of Sidelink processes supported by the V2X UE.

The minimum requirements are specified in Table 14.8-3 with the test parameters specified in Table 14.8-1 and Table 14.8-2 according to UE capability.

**Table 14.8-1: Test Parameters**

Parameter	Unit	Test 1
Communication resource pool configuration		As specified in Table A.9-5 (Configuration #5-V2X)
Active cell(s)		None
Sidelink UE $i$ , $0 \leq i \leq 9$	Sidelink Transmissions	PSCCH + PSSCH
	Timing offset (Note 1)	$\mu$ s
	Frequency offset (Note 2)	Hz
	Synchronization source	GNSS or GNSS-equivalent
	Propagation Channel	Static propagation condition No external noise sources are applied
	Antenna configuration	1x2
PSSCH RMC		CD.12
Note 1:	Time offset of Sidelink UE receive signal with respect to GNSS reference timing.	
Note 2:	Frequency offset of Sidelink UE with respect to GNSS reference frequency.	
Note 3:	Cyclic shift for PSCCH DMRS is randomly selected between {0, 3, 6, 9} for each PSCCH transmission.	



Table 14.8-2: Test Parameters

Parameter		Unit	Test 2
Communication resource pool configuration			As specified in Table A.9-5 (Configuration #5-V2X)
Active cell(s)			None
Sidelink UE $i$ , $0 \leq i \leq 19$	Sidelink Transmissions		PSCCH + PSSCH
	Timing offset (Note 1)	$\mu\text{s}$	0
	Frequency offset (Note 2)	Hz	0
	Synchronization source		GNSS or GNSS-equivalent
	Propagation Channel		Static propagation condition No external noise sources are applied
	Antenna configuration		1x2
PSSCH RMC			CD.10
Note 1: Time offset of Sidelink UE receive signal with respect to GNSS reference timing.			
Note 2: Frequency offset of Sidelink UE with respect to GNSS reference frequency.			
Note 3: Cyclic shift for PSCCH DMRS is randomly selected between {0, 3, 6, 9} for each PSCCH transmission.			

Table 14.8-3: Minimum performance

Test number	Bandwidth	PSCCH Reference channel	$\hat{E}_s$ at antenna port (dBm/15kHz)	Reference value
				Probability of missed PSCCH (%)
1	20 MHz	CC.8	-85	1
2	20 MHz	CC.8	-85	1

## 14.9 Sustained downlink data rate with active sidelink

The purpose of this test is to verify the WAN and V2X operation is not impacted with each other when UE is under concurrent operation. This test case applies to UEs support concurrent operation of V2X communication with E-UTRA uplink/downlink on the operating bands combinations listed in Table 5.5G-2.

The test parameters are in Table 14.9-1, and the test UE is expected to receive all PSSCH and PDSCH transmissions simultaneously.

For PDSCH, the test cases apply to UE categories and bandwidth as specified in Table 14.9-2. The minimum requirements for PSSCH are specified in Table 14.7-2, Table 14.10-3 and Table 14.10-4 with corresponding test applicability and the minimum requirements for PDSCH downlink data rate are specified in Table 14.9-3. Both PDSCH and PSSCH performance will be verified simultaneously. The TB success rate in the cellular link shall be sustained during at least 300 frames.

**Table 14.9-1: Test parameters for sustained downlink data rate (FDD 64QAM) and maximum PSSCH processing capability**

Parameter		Unit	Test 1
Communication resource pool configuration			As specified in Table A.9-4 (Configuration #4-V2X)
$N_{oc}$ at antenna port		dBm/15kHz	-98
Active cell(s)			Cell 1 (PCell)
Cell 1	Test parameters		As specified in Table 8.7.1-1 and Table 14.9-2
Active Sidelink UE(s)			Sidelink UE $i$ , $0 \leq i \leq 14$
Sidelink UE $i$ , $0 \leq i \leq 14$	Sidelink Transmissions		PSCCH + PSSCH
	Time gap between initial transmission and retransmission	Subframe	15
	Timing offset (Note 1)	$\mu$ s	0
	Frequency offset (Note 2)	Hz	0
	Synchronization		GNSS or GNSS-equivalent
Antenna configuration			1x2
Note 1: Time offset of Sidelink UE receive signal with respect to GNSS reference timing.			
Note 2: Frequency offset of Sidelink UE with respect to GNSS reference frequency.			
Note 3: 15 sidelink UEs should transmit one by one circularly for every subframe.			

**Table 14.9-2: Test cases for sustained data rate**

CA config	Maximum supported Bandwidth/ Bandwidth combination (MHz)	Cat. 1	Cat. 2	Cat. 3	Cat. 4	Cat. 6,7	Cat. 9,10	Cat 11, 12	DL Cat. 15
								DL Cat. 11,12	
Single carrier	10	1	2	3A	3A	3A	3A	3A	3A
	20	-	-	3	4	6	6	6	6

**Table 14.9-3: Minimum requirements (FDD 64QAM) for PDSCH**

Test	Bandwidth (MHz)	Number of bits of a DL-SCH transport block received within a TTI	Measurement channel	Reference value
				PDSCH TB success rate (%)
1	10	10296	R.31-1 FDD (NOTE 2)	95
2	10	25456	R.31-2 FDD (NOTE 2)	95
3	20	51024	R.31-3 FDD	95
3A	10	36696 (NOTE 1)	R.31-3A FDD (NOTE 2)	85
4	20	75376 (Note 2)	R.31-4 FDD	85
6	20	75376 (Note 2)	R.31-4 FDD	85
NOTE 1: 35160 bits for sub-frame 5.				
NOTE 2: 71112 bits for sub-frame 5.				

## 14.10 Soft buffer test (CA)

The purpose of this test is to verify the maximum number of bits per TTI supported by the V2X UE with UE SL-C-RX Category 4 for UEs supporting V2X CA.

For CA with 2 SL CCs, the requirements are specified in Table 14.10-3, based on single carrier requirement specified in Table 14.10-2, with the test parameters specified in Table 14.10-1.

For CA with 3 SL CCs, the requirements are specified in Table 14.10-4, based on single carrier requirement specified in Table 14.10-2, with the test parameters specified in Table 14.10-1.

Table 14.10-1: Test Parameters

Parameter	Unit	Test 1, 2	
Communication resource pool configuration		As specified in Table A.9-4 (Configuration #4-V2X)	
$N_{oc}$ at antenna port	dBm/15kHz	-98	
Active cell(s)		None	
V2X Tx format (SL-V2X-TxProfileList-r15)		SL-V2X-TxProfile-r15 = rel15	
Active Sidelink UE(s)		Sidelink UE $i$ , $0 \leq i \leq 14$	
Sidelink UE $i$ , $0 \leq i \leq 14$	Sidelink Transmissions	PSSCH + PSSCH	
	Time gap between initial transmission and retransmission	Subframe	15
	Timing offset (Note 1)	$\mu$ s	0
	Frequency offset (Note 2)	Hz	0
	Synchronization source		GNSS or GNSS-equivalent
	Antenna configuration		1x2
Note 1:	Time offset of Sidelink UE receive signal with respect to GNSS reference timing.		
Note 2:	Frequency offset of Sidelink UE with respect to GNSS reference frequency.		
Note 3:	15 sidelink UEs should transmit one by one circularly for every subframe.		

Table 14.10-2: Single carrier performance with different bandwidths for multiple CA configurations

Bandwidth	PSSCH Reference channel	Propagation condition	Reference value	
			PSSCH BLER (%)	SNR (dB) of PSSCH
10 MHz	CD.16	AWGN	5	12.0
20 MHz	CD.15	AWGN	5	12.0

Table 14.10-3: Minimum performance for CA with 2 SL CCs

Test num.	CA Bandwidth combination	Requirement	ue-CategorySL-C-RX
1	10+20 MHz	As specified in 14.10-2 per CC	SL-C-RX Category 4

Table 14.10-4: Minimum performance for CA with 3 SL CCs

Test num.	CA Bandwidth combination	Requirement	ue-CategorySL-C-RX
2	3x10 MHz	As specified in 14.10-2 per CC	SL-C-RX Category 4

## 14.11 PSSCH/PSSCH decoding capability test (CA)

The purpose of this test is to verify the maximum number of Sidelink processes and the maximum number of bits per TTI supported by the UE with UE SL-C-RX Category 4 for UEs supporting V2X CA.

For CA with 2 SL CCs, the requirements are specified in Table 14.11-4 based on single carrier requirement specified in Table 14.11-3, with the test parameters specified in Table 14.11-1 and Table 14.11-2 according to UE capability.

For CA with 3 SL CCs, the requirements are specified in Table 14.11-5 based on single carrier requirement specified in Table 14.11-3, with test parameters specified in Table 14.11-1 and Table 14.11-2 according to UE capability.

Table 14.11-1: Test Parameters

Parameter	Unit	Test 1	Test 2
Communication resource pool configuration		As specified in Table A.9-5 and A.9-6 (Configuration #5-V2X and #6-V2X)	As specified in Table A.9-6 (Configuration #6-V2X)
V2X Tx format (SL-V2X-TxProfileList-r15)		SL-V2X-TxProfile-r15 = rel15	
Active cell(s)		None	
Sidelink UE $i$ , $0 \leq i \leq 14$	Sidelink Transmissions	PSCCH + PSSCH	
	Timing offset (Note 1)	$\mu\text{s}$	0
	Frequency offset (Note 2)	Hz	0
	Synchronization source	GNSS or GNSS-equivalent	
	Propagation Channel	Static propagation condition No external noise sources are applied	
	Antenna configuration	1x2	
	PSSCH RMC	CD.17 and CD.18	CD.18
Note 1: Time offset of Sidelink UE receive signal with respect to GNSS reference timing. Note 2: Frequency offset of Sidelink UE with respect to GNSS reference frequency. Note 3: Cyclic shift for PSCCH DMRS is randomly selected between {0, 3, 6, 9} for each PSCCH transmission.			

Table 14.11-2: Test Parameters

Parameter	Unit	Test 3	Test 4
Communication resource pool configuration		As specified in Table A.9-5 and A.9-6 (Configuration #5-V2X and #6-V2X)	As specified in Table A.9-6 (Configuration #6-V2X)
V2X Tx format (SL-V2X-TxProfileList-r15)		SL-V2X-TxProfile-r15 = rel15	
Active cell(s)		None	
Sidelink UE $i$ , $0 \leq i \leq 29$	Sidelink Transmissions	PSCCH + PSSCH	
	Timing offset (Note 1)	$\mu\text{s}$	0
	Frequency offset (Note 2)	Hz	0
	Synchronization source	GNSS or GNSS-equivalent	
	Propagation Channel	Static propagation condition No external noise sources are applied	
	Antenna configuration	1x2	
	PSSCH RMC	CD.19 and CD.20	CD.20
Note 1: Time offset of Sidelink UE receive signal with respect to GNSS reference timing. Note 2: Frequency offset of Sidelink UE with respect to GNSS reference frequency. Note 3: Cyclic shift for PSCCH DMRS is randomly selected between {0, 3, 6, 9} for each PSCCH transmission.			

Table 14.11-3: Single carrier performance with different bandwidths for multiple CA configurations

Bandwidth	PSCCH Reference channel	$\hat{E}_s$ at antenna port (dBm/15kHz)	Reference value
			Probability of missed PSCCH (%)
10 MHz	CC.8	-85	1
20 MHz	CC.8	-85	1

Table 14.11-4: Minimum performance for CA configuration with 2 SL CCs

Test number	CA Bandwidth combination (MHz)	Minimum performance requirement
1	10+20	As defined in Table 14.11-3 per CC
3	10+20	As defined in Table 14.11-3 per CC

**Table 14.11-5: Minimum performance for CA configuration with 3 SL CCs**

Test number	CA Bandwidth combination (MHz)	Minimum performance requirement
2	3x10	As defined in Table 14.11-3 per CC
4	3x10	As defined in Table 14.11-3 per CC

---

## Annex A (normative): Measurement channels

### A.1 General

The throughput values defined in the measurement channels specified in Annex A, are calculated and are valid per datastream (codeword). For multi-stream (more than one codeword) transmissions, the throughput referenced in the minimum requirements is the sum of throughputs of all datastreams (codewords).

The UE category entry in the definition of the reference measurement channel in Annex A is only informative and reveals the UE categories, which can support the corresponding measurement channel. Whether the measurement channel is used for testing a certain UE category or not is specified in the individual minimum requirements.

---

### A.2 UL reference measurement channels

#### A.2.1 General

The measurement channels in the following subclauses are defined to derive the requirements in clause 6 (Transmitter Characteristics) and clause 7 (Receiver Characteristics). The measurement channels represent example configurations of physical channels for different data rates.

##### A.2.1.1 Applicability and common parameters

The UL reference measurement channels comprise transmission of PUSCH and Demodulation Reference signals only. The following conditions apply:

- 1 HARQ transmission
- Cyclic Prefix normal
- PUSCH hopping off
- Link adaptation off
- Demodulation Reference signal as per TS 36.211 [4] subclause 5.5.2.1.2.

Where ACK/NACK is transmitted, it is assumed to be multiplexed on PUSCH as per TS 36.212 [5] subclause 5.2.2.6.

- ACK/NACK 1 bit
- ACK/NACK mapping adjacent to Demodulation Reference symbol
- ACK/NACK resources punctured into data
- Max number of resources for ACK/NACK: 4 SC-FDMA symbols per subframe
- No CQI transmitted, no RI transmitted

##### A.2.1.2 Determination of payload size

The algorithm for determining the payload size  $A$  is as follows; given a desired coding rate  $R$  and radio block allocation  $N_{RB}$

1. Calculate the number of channel bits  $N_{ch}$  that can be transmitted during the first transmission of a given sub-frame.
2. Find  $A$  such that the resulting coding rate is as close to  $R$  as possible, that is,

$$\min |R - (A + 24 * (N_{CB} + 1)) / N_{ch}|, \text{ where } N_{CB} = \begin{cases} 0, & \text{if } C = 1 \\ C, & \text{if } C > 1 \end{cases}$$

subject to

- A is a valid TB size according to section 7.1.7 of TS 36.213 [6] assuming an allocation of  $N_{RB}$  resource blocks.
- C is the number of Code Blocks calculated according to section 5.1.2 of TS 36.212 [5].
- For RMC-s, which at the nominal target coding rate do not cover all the possible UE categories for the given modulation, reduce the target coding rate gradually (within the same modulation), until the maximal possible number of UE categories is covered.

3. If there is more than one A that minimises the equation above, then the larger value is chosen per default and the chosen code rate should not exceed 0.93.

### A.2.1.3 Overview of UL reference measurement channels

In Table A.2.1.3-1 to A.2.1.3-1K are listed the UL reference measurement channels specified in annexes A.2.2 and A.2.3 of this release of TS 36.101. This table is informative and serves only to a better overview. The reference for the concrete reference measurement channels and corresponding implementation's parameters as to be used for requirements are annexes A.2.2 and A.2.3 as appropriate.

**Table A.2.1.3-1: Overview of UL reference measurement channels (FDD, Full RB allocation, QPSK)**

Duplex	Table	Name	BW	Mod	TCR	RB	RB Off set	UE Cat eg	Notes
FDD	Table A.2.2.1.1-1		1.4	QPSK	1/3	6		≥ 1	
FDD	Table A.2.2.1.1-1		3	QPSK	1/3	15		≥ 1	
FDD	Table A.2.2.1.1-1		5	QPSK	1/3	25		≥ 1	
FDD	Table A.2.2.1.1-1		10	QPSK	1/3	50		≥ 1	
FDD	Table A.2.2.1.1-1		15	QPSK	1/5	75		≥ 1	
FDD	Table A.2.2.1.1-1		20	QPSK	1/6	100		≥ 1	
FDD / HD-FDD	Table A.2.2.1.1-1a		1.4	QPSK	1/3	6		-	UE UL category 0
FDD / HD-FDD	Table A.2.2.1.1-1a		3	QPSK	1/5	15		-	UE UL category 0
FDD / HD-FDD	Table A.2.2.1.1-1a		5	QPSK	1/8	25		-	UE UL category 0
FDD / HD-FDD	Table A.2.2.1.1-1a		10	QPSK	1/10	36		-	UE UL category 0
FDD / HD-FDD	Table A.2.2.1.1-1a		15	QPSK	1/10	36		-	UE UL category 0
FDD / HD-FDD	Table A.2.2.1.1-1a		20	QPSK	1/10	36		-	UE UL category 0
FDD / HD-FDD	Table A.2.2.1.1-1b		1.4	QPSK	1/3	6		-	UE UL category M1
FDD / HD-FDD	Table A.2.2.1.1-1b		3	QPSK	1/3	6		-	UE UL category M1
FDD / HD-FDD	Table A.2.2.1.1-1b		5	QPSK	1/3	6		-	UE UL category M1
FDD / HD-FDD	Table A.2.2.1.1-1b		10	QPSK	1/3	6		-	UE UL category M1
FDD / HD-FDD	Table A.2.2.1.1-1b		15	QPSK	1/3	6		-	UE UL category M1
FDD / HD-FDD	Table A.2.2.1.1-1b		20	QPSK	1/3	6		-	UE UL category M1
FDD / HD-FDD	Table A.2.2.1.1-1c		1.4	QPSK	1/3	6		-	UE UL category M2
FDD / HD-FDD	Table A.2.2.1.1-1c		3	QPSK	1/3	12		-	UE UL category M2
FDD / HD-FDD	Table A.2.2.1.1-1c		5	QPSK	1/3	24		-	UE UL category M2
FDD / HD-FDD	Table A.2.2.1.1-1c		10	QPSK	1/3	24		-	UE UL category M2
FDD / HD-FDD	Table A.2.2.1.1-1c		15	QPSK	1/3	24		-	UE UL category M2
FDD / HD-FDD	Table A.2.2.1.1-1c		20	QPSK	1/3	24		-	UE UL category M2

Table A.2.1.3-1A: Overview of UL reference measurement channels (FDD, Full RB allocation, 16-QAM)

Duplex	Table	Name	BW	Mod	TCR	RB	RB Off set	UE Cat eg	Notes
FDD	Table A.2.2.1.2-1		1.4	16QAM	3/4	6		≥ 1	
FDD	Table A.2.2.1.2-1		3	16QAM	1/2	15		≥ 1	
FDD	Table A.2.2.1.2-1		5	16QAM	1/3	25		≥ 1	
FDD	Table A.2.2.1.2-1		10	16QAM	3/4	50		≥ 2	
FDD	Table A.2.2.1.2-1		15	16QAM	1/2	75		≥ 2	
FDD	Table A.2.2.1.2-1		20	16QAM	1/3	100		≥ 2	
FDD / HD-FDD	Table A.2.2.1.2-1a		1.4	16QAM	1/3	5		-	UE UL category 0
FDD / HD-FDD	Table A.2.2.1.2-1a		3	16QAM	1/3	5		-	UE UL category 0
FDD / HD-FDD	Table A.2.2.1.2-1a		5	16QAM	1/3	5		-	UE UL category 0
FDD / HD-FDD	Table A.2.2.1.2-1a		10	16QAM	1/3	5		-	UE UL category 0
FDD / HD-FDD	Table A.2.2.1.2-1a		15	16QAM	1/3	5		-	UE UL category 0
FDD / HD-FDD	Table A.2.2.1.2-1a		20	16QAM	1/3	5		-	UE UL category 0
FDD / HD-FDD	Table A.2.2.1.2-1b		1.4	16QAM	1/3	5		-	UE UL category M1
FDD / HD-FDD	Table A.2.2.1.2-1b		3	16QAM	1/3	5		-	UE UL category M1
FDD / HD-FDD	Table A.2.2.1.2-1b		5	16QAM	1/3	5		-	UE UL category M1
FDD / HD-FDD	Table A.2.2.1.2-1b		10	16QAM	1/3	5		-	UE UL category M1
FDD / HD-FDD	Table A.2.2.1.2-1b		15	16QAM	1/3	5		-	UE UL category M1
FDD / HD-FDD	Table A.2.2.1.2-1b		20	16QAM	1/3	5		-	UE UL category M1
FDD / HD-FDD	Table A.2.2.1.2-1c		1.4	16QAM	1/3	6		-	UE UL category M2
FDD / HD-FDD	Table A.2.2.1.2-1c		3	16QAM	1/3	12		-	UE UL category M2
FDD / HD-FDD	Table A.2.2.1.2-1c		5	16QAM	1/3	24		-	UE UL category M2
FDD / HD-FDD	Table A.2.2.1.2-1c		10	16QAM	1/3	24		-	UE UL category M2
FDD / HD-FDD	Table A.2.2.1.2-1c		15	16QAM	1/3	24		-	UE UL category M2
FDD / HD-FDD	Table A.2.2.1.2-1c		20	16QAM	1/3	24		-	UE UL category M2

Table A.2.1.3-1B: Overview of UL reference measurement channels (FDD, Full RB allocation, 64-QAM)

Duplex	Table	Name	BW	Mod	TCR	RB	RB Off set	UE Cat eg	Notes
FDD	Table A.2.2.1.3-1		1.4	64QAM	3/4	6		5,8	UL category 5, 8, 13, 14
FDD	Table A.2.2.1.3-1		3	64QAM	3/4	15		5,8	UL category 5, 8, 13, 14
FDD	Table A.2.2.1.3-1		5	64QAM	3/4	25		5,8	UL category 5, 8, 13, 14
FDD	Table A.2.2.1.3-1		10	64QAM	3/4	50		5,8	UL category 5, 8, 13, 14
FDD	Table A.2.2.1.3-1		15	64QAM	3/4	75		5,8	UL category 5, 8, 13, 14
FDD	Table A.2.2.1.3-1		20	64QAM	3/4	100		5,8	UL category 5, 8, 13, 14



**Table A.2.1.3-1Ba: Overview of UL reference measurement channels (FDD, Full RB allocation, 256-QAM)**

Duplex	Table	Name	BW	Mod	TCR	RB	RB Off set	UE Cat eg	Notes
FDD	Table A.2.2.1.4-1		1.4	256QAM	4/5	6			UL category $\geq 15$
FDD	Table A.2.2.1.4-1		3	256QAM	4/5	15			UL category $\geq 15$
FDD	Table A.2.2.1.4-1		5	256QAM	4/5	25			UL category $\geq 15$
FDD	Table A.2.2.1.4-1		10	256QAM	4/5	50			UL category $\geq 15$
FDD	Table A.2.2.1.4-1		15	256QAM	4/5	75			UL category $\geq 15$
FDD	Table A.2.2.1.4-1		20	256QAM	4/5	100			UL category $\geq 15$

**Table A.2.1.3-1C: Overview of UL reference measurement channels (FDD, Partial RB allocation, QPSK)**

Duplex	Table	Name	BW	Mod	TCR	RB	RB Off set	UE Cat eg	Notes
FDD	Table A.2.2.2.1-1		1.4 - 20	QPSK	1/3	1		≥ 1	
FDD	Table A.2.2.2.1-1		1.4 - 20	QPSK	1/3	2		≥ 1	
FDD	Table A.2.2.2.1-1		1.4 - 20	QPSK	1/3	3		≥ 1	
FDD	Table A.2.2.2.1-1		1.4 - 20	QPSK	1/3	4		≥ 1	
FDD	Table A.2.2.2.1-1		1.4 - 20	QPSK	1/3	5		≥ 1	
FDD	Table A.2.2.2.1-1		3 - 20	QPSK	1/3	6		≥ 1	
FDD	Table A.2.2.2.1-1		3 - 20	QPSK	1/3	8		≥ 1	
FDD	Table A.2.2.2.1-1		3 - 20	QPSK	1/3	9		≥ 1	
FDD	Table A.2.2.2.1-1		3 - 20	QPSK	1/3	10		≥ 1	
FDD	Table A.2.2.2.1-1		3 - 20	QPSK	1/3	12		≥ 1	
FDD	Table A.2.2.2.1-1		5 - 20	QPSK	1/3	15		≥ 1	
FDD	Table A.2.2.2.1-1		5 - 20	QPSK	1/3	16		≥ 1	
FDD	Table A.2.2.2.1-1		5 - 20	QPSK	1/3	18		≥ 1	
FDD	Table A.2.2.2.1-1		5 - 20	QPSK	1/3	20		≥ 1	
FDD	Table A.2.2.2.1-1		5 - 20	QPSK	1/3	24		≥ 1	
FDD	Table A.2.2.2.1-1		10 - 20	QPSK	1/3	25		≥ 1	
FDD	Table A.2.2.2.1-1		10 - 20	QPSK	1/3	27		≥ 1	
FDD	Table A.2.2.2.1-1		10 - 20	QPSK	1/3	30		≥ 1	
FDD	Table A.2.2.2.1-1		10 - 20	QPSK	1/3	32		≥ 1	
FDD	Table A.2.2.2.1-1		10 - 20	QPSK	1/3	36		≥ 1	
FDD	Table A.2.2.2.1-1		10 - 20	QPSK	1/3	40		≥ 1	
FDD	Table A.2.2.2.1-1		10 - 20	QPSK	1/3	45		≥ 1	
FDD	Table A.2.2.2.1-1		10 - 20	QPSK	1/3	48		≥ 1	
FDD	Table A.2.2.2.1-1		15 - 20	QPSK	1/3	50		≥ 1	
FDD	Table A.2.2.2.1-1		15 - 20	QPSK	1/3	54		≥ 1	
FDD	Table A.2.2.2.1-1		15 - 20	QPSK	1/4	60		≥ 1	
FDD	Table A.2.2.2.1-1		15 - 20	QPSK	1/4	64		≥ 1	
FDD	Table A.2.2.2.1-1		15 - 20	QPSK	1/4	72		≥ 1	
FDD	Table A.2.2.2.1-1		20	QPSK	1/5	75		≥ 1	
FDD	Table A.2.2.2.1-1		20	QPSK	1/5	80		≥ 1	
FDD	Table A.2.2.2.1-1		20	QPSK	1/5	81		≥ 1	
FDD	Table A.2.2.2.1-1		20	QPSK	1/6	90		≥ 1	
FDD	Table A.2.2.2.1-1		20	QPSK	1/6	96		≥ 1	
FDD / HD-FDD	Table A.2.2.2.1-1a		1.4 - 20	QPSK	1/3	1		-	UE UL category 0
FDD / HD-FDD	Table A.2.2.2.1-1a		1.4 - 20	QPSK	1/3	2		-	UE UL category 0
FDD / HD-FDD	Table A.2.2.2.1-1a		1.4 - 20	QPSK	1/3	3		-	UE UL category 0
FDD / HD-FDD	Table A.2.2.2.1-1a		1.4 - 20	QPSK	1/3	4		-	UE UL category 0
FDD / HD-FDD	Table A.2.2.2.1-1a		1.4 - 20	QPSK	1/3	5		-	UE UL category 0
FDD / HD-FDD	Table A.2.2.2.1-1a		3-20	QPSK	1/3	6		-	UE UL category 0
FDD / HD-FDD	Table A.2.2.2.1-1a		3-20	QPSK	1/3	8		-	UE UL category 0
FDD / HD-FDD	Table A.2.2.2.1-1a		3-20	QPSK	1/3	9		-	UE UL category 0
FDD / HD-FDD	Table A.2.2.2.1-1a		3-20	QPSK	1/3	10		-	UE UL category 0
FDD / HD-FDD	Table A.2.2.2.1-1a		3-20	QPSK	1/4	12		-	UE UL category 0
FDD / HD-FDD	Table A.2.2.2.1-1a		5-20	QPSK	1/5	15		-	UE UL category 0
FDD / HD-FDD	Table A.2.2.2.1-1a		5-20	QPSK	1/5	16		-	UE UL category 0
FDD / HD-FDD	Table A.2.2.2.1-1a		5-20	QPSK	1/6	18		-	UE UL category 0

ETSI

FDD / HD-FDD	Table A.2.2.2.1-1a		5-20	QPSK	1/6	20		-	UE UL category 0
FDD / HD-FDD	Table A.2.2.2.1-1a		5-20	QPSK	1/8	24		-	UE UL category 0
FDD / HD-FDD	Table A.2.2.2.1-1a		10-20	QPSK	1/8	25		-	UE UL category 0
FDD / HD-FDD	Table A.2.2.2.1-1a		10-20	QPSK	1/8	27		-	UE UL category 0
FDD / HD-FDD	Table A.2.2.2.1-1a		10-20	QPSK	1/10	30		-	UE UL category 0
FDD / HD-FDD	Table A.2.2.2.1-1b		1.4-20	QPSK	1/3	1		-	UE UL category M1
FDD / HD-FDD	Table A.2.2.2.1-1b		1.4-20	QPSK	1/3	2		-	UE UL category M1
FDD / HD-FDD	Table A.2.2.2.1-1b		1.4-20	QPSK	1/3	3		-	UE UL category M1
FDD / HD-FDD	Table A.2.2.2.1-1b		1.4-20	QPSK	1/3	4		-	UE UL category M1
FDD / HD-FDD	Table A.2.2.2.1-1b		1.4-20	QPSK	1/3	5		-	UE UL category M1
FDD / HD-FDD	Table A.2.2.2.1-1b		3-20	QPSK	1/3	6		-	UE UL category M1
FDD / HD-FDD	Table A.2.2.2.1-1c		1.4-20	QPSK	1/3	1		-	UE UL category M2
FDD / HD-FDD	Table A.2.2.2.1-1c		1.4-20	QPSK	1/3	2		-	UE UL category M2
FDD / HD-FDD	Table A.2.2.2.1-1c		1.4-20	QPSK	1/3	3		-	UE UL category M2
FDD / HD-FDD	Table A.2.2.2.1-1c		1.4-20	QPSK	1/3	4		-	UE UL category M2
FDD / HD-FDD	Table A.2.2.2.1-1c		1.4-20	QPSK	1/3	5		-	UE UL category M2
FDD / HD-FDD	Table A.2.2.2.1-1c		3-20	QPSK	1/3	6		-	UE UL category M2
FDD / HD-FDD	Table A.2.2.2.1-1c		3-20	QPSK	1/3	9		-	UE UL category M2
FDD / HD-FDD	Table A.2.2.2.1-1c		3-20	QPSK	1/3	12		-	UE UL category M2
FDD / HD-FDD	Table A.2.2.2.1-1c		5-20	QPSK	1/3	15		-	UE UL category M2
FDD / HD-FDD	Table A.2.2.2.1-1c		5-20	QPSK	1/3	18		-	UE UL category M2
FDD / HD-FDD	Table A.2.2.2.1-1c		5-20	QPSK	1/3	21		-	UE UL category M2

**Table A.2.1.3-1D: Overview of UL reference measurement channels (FDD, Partial RB allocation, 16-QAM)**

Duplex	Table	Name	BW	Mod	TCR	RB	RB Off set	UE Cat eg	Notes
FDD	Table A.2.2.2.2-1		1.4 - 20	16QAM	3/4	1		≥ 1	
FDD	Table A.2.2.2.2-1		1.4 - 20	16QAM	3/4	2		≥ 1	
FDD	Table A.2.2.2.2-1		1.4 - 20	16QAM	3/4	3		≥ 1	
FDD	Table A.2.2.2.2-1		1.4 - 20	16QAM	3/4	4		≥ 1	
FDD	Table A.2.2.2.2-1		1.4 - 20	16QAM	3/4	5		≥ 1	
FDD	Table A.2.2.2.2-1		3 - 20	16QAM	3/4	6		≥ 1	
FDD	Table A.2.2.2.2-1		3 - 20	16QAM	3/4	8		≥ 1	
FDD	Table A.2.2.2.2-1		3 - 20	16QAM	3/4	9		≥ 1	
FDD	Table A.2.2.2.2-1		3 - 20	16QAM	3/4	10		≥ 1	
FDD	Table A.2.2.2.2-1		3 - 20	16QAM	3/4	12		≥ 1	
FDD	Table A.2.2.2.2-1		5 - 20	16QAM	1/2	15		≥ 1	
FDD	Table A.2.2.2.2-1		5 - 20	16QAM	1/2	16		≥ 1	
FDD	Table A.2.2.2.2-1		5 - 20	16QAM	1/2	18		≥ 1	
FDD	Table A.2.2.2.2-1		5 - 20	16QAM	1/3	20		≥ 1	
FDD	Table A.2.2.2.2-1		5 - 20	16QAM	1/3	24		≥ 1	
FDD	Table A.2.2.2.2-1		10 - 20	16QAM	1/3	25		≥ 1	
FDD	Table A.2.2.2.2-1		10 - 20	16QAM	1/3	27		≥ 1	
FDD	Table A.2.2.2.2-1		10 - 20	16QAM	3/4	30		≥ 2	
FDD	Table A.2.2.2.2-1		10 - 20	16QAM	3/4	32		≥ 2	
FDD	Table A.2.2.2.2-1		10 - 20	16QAM	3/4	36		≥ 2	
FDD	Table A.2.2.2.2-1		10 - 20	16QAM	3/4	40		≥ 2	
FDD	Table A.2.2.2.2-1		10 - 20	16QAM	3/4	45		≥ 2	
FDD	Table A.2.2.2.2-1		10 - 20	16QAM	3/4	48		≥ 2	
FDD	Table A.2.2.2.2-1		15 - 20	16QAM	3/4	50		≥ 2	
FDD	Table A.2.2.2.2-1		15 - 20	16QAM	3/4	54		≥ 2	
FDD	Table A.2.2.2.2-1		15 - 20	16QAM	2/3	60		≥ 2	
FDD	Table A.2.2.2.2-1		15 - 20	16QAM	2/3	64		≥ 2	
FDD	Table A.2.2.2.2-1		15 - 20	16QAM	1/2	72		≥ 2	
FDD	Table A.2.2.2.2-1		20	16QAM	1/2	75		≥ 2	
FDD	Table A.2.2.2.2-1		20	16QAM	1/2	80		≥ 2	
FDD	Table A.2.2.2.2-1		20	16QAM	1/2	81		≥ 2	
FDD	Table A.2.2.2.2-1		20	16QAM	2/5	90		≥ 2	
FDD	Table A.2.2.2.2-1		20	16QAM	2/5	96		≥ 2	
FDD / HD-FDD	Table A.2.2.2.2-1a		1.4 - 20	16QAM	3/4	1		-	UE UL category 0
FDD / HD-FDD	Table A.2.2.2.2-1a		1.4 - 20	16QAM	3/4	2		-	UE UL category 0
FDD / HD-FDD	Table A.2.2.2.2-1a		1.4 - 20	16QAM	2/5	4		-	UE UL category 0
FDD / HD-FDD	Table A.2.2.2.2-1b		1.4 - 20	16QAM	3/4	1		-	UE UL category M1
FDD / HD-FDD	Table A.2.2.2.2-1b		1.4 - 20	16QAM	3/4	2		-	UE UL category M1
FDD / HD-FDD	Table A.2.2.2.2-1b		1.4 - 20	16QAM	2/5	4		-	UE UL category M1
FDD / HD-FDD	Table A.2.2.2.2-1c		1.4 - 20	16QAM	1/2	1		-	UE UL category M2
FDD / HD-FDD	Table A.2.2.2.2-1c		1.4 - 20	16QAM	1/2	2		-	UE UL category M2
FDD / HD-FDD	Table A.2.2.2.2-1c		1.4 - 20	16QAM	1/2	3		-	UE UL category M2
FDD / HD-FDD	Table A.2.2.2.2-1c		1.4 - 20	16QAM	1/2	4		-	UE UL category M2
FDD / HD-FDD	Table A.2.2.2.2-1c		1.4 - 20	16QAM	1/2	5		-	UE UL category M2
FDD / HD-FDD	Table A.2.2.2.2-1c		3 - 20	16QAM	1/2	6		-	UE UL category M2
FDD / HD-FDD	Table A.2.2.2.2-1c		3 - 20	16QAM	1/2	9		-	UE UL category M2

ETSI

FDD / HD-FDD	Table A.2.2.2.2-1c		3 - 20	16QAM	1/2	12		-	UE UL category M2
FDD / HD-FDD	Table A.2.2.2.2-1c		5 - 20	16QAM	1/2	15		-	UE UL category M2
FDD / HD-FDD	Table A.2.2.2.2-1c		5 - 20	16QAM	1/2	18		-	UE UL category M2
FDD / HD-FDD	Table A.2.2.2.2-1c		5 - 20	16QAM	1/2	21		-	UE UL category M2
FDD / HD-FDD	Table A.2.2.2.2-1c		5 - 20	16QAM	1/2	24		-	UE UL category M2

**Table A.2.1.3-1E: Overview of UL reference measurement channels (FDD, Partial RB allocation, 64-QAM)**

Duplex	Table	Name	BW	Mod	TCR	RB	RB Off set	UE Cat eg	Notes
FDD	Table A.2.2.2.3-1		1.4 - 20	64QAM	3/4	1		5,8	UL category 5, 8, 13, 14
FDD	Table A.2.2.2.3-1		1.4 - 20	64QAM	3/4	2		5,8	UL category 5, 8, 13, 14
FDD	Table A.2.2.2.3-1		1.4 - 20	64QAM	3/4	3		5,8	UL category 5, 8, 13, 14
FDD	Table A.2.2.2.3-1		1.4 - 20	64QAM	3/4	4		5,8	UL category 5, 8, 13, 14
FDD	Table A.2.2.2.3-1		1.4 - 20	64QAM	3/4	5		5,8	UL category 5, 8, 13, 14
FDD	Table A.2.2.2.3-1		3 - 20	64QAM	3/4	6		5,8	UL category 5, 8, 13, 14
FDD	Table A.2.2.2.3-1		3 - 20	64QAM	3/4	8		5,8	UL category 5, 8, 13, 14
FDD	Table A.2.2.2.3-1		3 - 20	64QAM	3/4	9		5,8	UL category 5, 8, 13, 14
FDD	Table A.2.2.2.3-1		3 - 20	64QAM	3/4	10		5,8	UL category 5, 8, 13, 14
FDD	Table A.2.2.2.3-1		3 - 20	64QAM	3/4	12		5,8	UL category 5, 8, 13, 14
FDD	Table A.2.2.2.3-1		5 - 20	64QAM	3/4	15		5,8	UL category 5, 8, 13, 14
FDD	Table A.2.2.2.3-1		5 - 20	64QAM	3/4	16		5,8	UL category 5, 8, 13, 14
FDD	Table A.2.2.2.3-1		5 - 20	64QAM	3/4	18		5,8	UL category 5, 8, 13, 14
FDD	Table A.2.2.2.3-1		5 - 20	64QAM	3/4	20		5,8	UL category 5, 8, 13, 14
FDD	Table A.2.2.2.3-1		5 - 20	64QAM	3/4	24		5,8	UL category 5, 8, 13, 14
FDD	Table A.2.2.2.3-1		10 - 20	64QAM	3/4	25		5,8	UL category 5, 8, 13, 14
FDD	Table A.2.2.2.3-1		10 - 20	64QAM	3/4	27		5,8	UL category 5, 8, 13, 14
FDD	Table A.2.2.2.3-1		10 - 20	64QAM	3/4	30		5,8	UL category 5, 8, 13, 14
FDD	Table A.2.2.2.3-1		10 - 20	64QAM	3/4	32		5,8	UL category 5, 8, 13, 14
FDD	Table A.2.2.2.3-1		10 - 20	64QAM	3/4	36		5,8	UL category 5, 8, 13, 14
FDD	Table A.2.2.2.3-1		10 - 20	64QAM	3/4	40		5,8	UL category 5, 8, 13, 14
FDD	Table A.2.2.2.3-1		10 - 20	64QAM	3/4	45		5,8	UL category 5, 8, 13, 14
FDD	Table A.2.2.2.3-1		10 - 20	64QAM	3/4	48		5,8	UL category 5, 8, 13, 14
FDD	Table A.2.2.2.3-1		15 - 20	64QAM	3/4	50		5,8	UL category 5, 8, 13, 14
FDD	Table A.2.2.2.3-1		15 - 20	64QAM	3/4	54		5,8	UL category 5, 8, 13, 14
FDD	Table A.2.2.2.3-1		15 - 20	64QAM	3/4	60		5,8	UL category 5, 8, 13, 14
FDD	Table A.2.2.2.3-1		15 - 20	64QAM	3/4	64		5,8	UL category 5, 8, 13, 14
FDD	Table A.2.2.2.3-1		15 - 20	64QAM	3/4	72		5,8	UL category 5, 8, 13, 14
FDD	Table A.2.2.2.3-1		20	64QAM	3/4	75		5,8	UL category 5, 8, 13, 14
FDD	Table A.2.2.2.3-1		20	64QAM	3/4	80		5,8	UL category 5, 8, 13, 14
FDD	Table A.2.2.2.3-1		20	64QAM	3/4	81		5,8	UL category 5, 8, 13, 14
FDD	Table A.2.2.2.3-1		20	64QAM	3/4	90		5,8	UL category 5, 8, 13, 14
FDD	Table A.2.2.2.3-1		20	64QAM	3/4	96		5,8	UL category 5, 8, 13, 14



**Table A.2.1.3-1Ea: Overview of UL reference measurement channels (FDD, Partial RB allocation, 256-QAM)**

Duplex	Table	Name	BW	Mod	TCR	RB	RB Off set	UE Cat eg	Notes
FDD	Table A.2.2.2.4-1		1.4 - 20	256QAM	4/5	1			UL category $\geq$ 15
FDD	Table A.2.2.2.4-1		1.4 - 20	256QAM	4/5	2			UL category $\geq$ 15
FDD	Table A.2.2.2.4-1		1.4 - 20	256QAM	4/5	3			UL category $\geq$ 15
FDD	Table A.2.2.2.4-1		1.4 - 20	256QAM	4/5	4			UL category $\geq$ 15
FDD	Table A.2.2.2.4-1		1.4 - 20	256QAM	4/5	5			UL category $\geq$ 15
FDD	Table A.2.2.2.4-1		3 - 20	256QAM	4/5	6			UL category $\geq$ 15
FDD	Table A.2.2.2.4-1		3 - 20	256QAM	4/5	8			UL category $\geq$ 15
FDD	Table A.2.2.2.4-1		3 - 20	256QAM	4/5	9			UL category $\geq$ 15
FDD	Table A.2.2.2.4-1		3 - 20	256QAM	4/5	10			UL category $\geq$ 15
FDD	Table A.2.2.2.4-1		3 - 20	256QAM	4/5	12			UL category $\geq$ 15
FDD	Table A.2.2.2.4-1		5 - 20	256QAM	4/5	15			UL category $\geq$ 15
FDD	Table A.2.2.2.4-1		5 - 20	256QAM	4/5	16			UL category $\geq$ 15
FDD	Table A.2.2.2.4-1		5 - 20	256QAM	4/5	18			UL category $\geq$ 15
FDD	Table A.2.2.2.4-1		5 - 20	256QAM	4/5	20			UL category $\geq$ 15
FDD	Table A.2.2.2.4-1		5 - 20	256QAM	4/5	24			UL category $\geq$ 15
FDD	Table A.2.2.2.4-1		10 - 20	256QAM	4/5	25			UL category $\geq$ 15
FDD	Table A.2.2.2.4-1		10 - 20	256QAM	4/5	27			UL category $\geq$ 15
FDD	Table A.2.2.2.4-1		10 - 20	256QAM	4/5	30			UL category $\geq$ 15
FDD	Table A.2.2.2.4-1		10 - 20	256QAM	4/5	32			UL category $\geq$ 15
FDD	Table A.2.2.2.4-1		10 - 20	256QAM	4/5	36			UL category $\geq$ 15
FDD	Table A.2.2.2.4-1		10 - 20	256QAM	4/5	40			UL category $\geq$ 15
FDD	Table A.2.2.2.4-1		10 - 20	256QAM	4/5	45			UL category $\geq$ 15
FDD	Table A.2.2.2.4-1		10 - 20	256QAM	4/5	48			UL category $\geq$ 15
FDD	Table A.2.2.2.4-1		15 - 20	256QAM	4/5	50			UL category $\geq$ 15
FDD	Table A.2.2.2.4-1		15 - 20	256QAM	4/5	54			UL category $\geq$ 15
FDD	Table A.2.2.2.4-1		15 - 20	256QAM	4/5	60			UL category $\geq$ 15
FDD	Table A.2.2.2.4-1		15 - 20	256QAM	4/5	64			UL category $\geq$ 15
FDD	Table A.2.2.2.4-1		15 - 20	256QAM	4/5	72			UL category $\geq$ 15
FDD	Table A.2.2.2.4-1		20	256QAM	4/5	75			UL category $\geq$ 15
FDD	Table A.2.2.2.4-1		20	256QAM	4/5	80			UL category $\geq$ 15
FDD	Table A.2.2.2.4-1		20	256QAM	4/5	81			UL category $\geq$ 15
FDD	Table A.2.2.2.4-1		20	256QAM	4/5	90			UL category $\geq$ 15
FDD	Table A.2.2.2.4-1		20	256QAM	4/5	96			UL category $\geq$ 15

Table A.2.1.3-1F: Overview of UL reference measurement channels (TDD, Full RB allocation, QPSK)

Duplex	Table	Name	BW	Mod	TCR	RB	RB Off set	UE Cat eg	Notes
TDD	Table A.2.3.1.1-1		1.4	QPSK	1/3	6		≥ 1	
TDD	Table A.2.3.1.1-1		3	QPSK	1/3	15		≥ 1	
TDD	Table A.2.3.1.1-1		5	QPSK	1/3	25		≥ 1	
TDD	Table A.2.3.1.1-1		10	QPSK	1/3	50		≥ 1	
TDD	Table A.2.3.1.1-1		15	QPSK	1/5	75		≥ 1	
TDD	Table A.2.3.1.1-1		20	QPSK	1/6	100		≥ 1	
TDD	Table A.2.3.1.1-1A		1.4	QPSK	1/3	6		≥ 1	UL-DL configuration 0
TDD	Table A.2.3.1.1-1A		3	QPSK	1/3	15		≥ 1	UL-DL configuration 0
TDD	Table A.2.3.1.1-1A		5	QPSK	1/3	25		≥ 1	UL-DL configuration 0
TDD	Table A.2.3.1.1-1A		10	QPSK	1/3	50		≥ 1	UL-DL configuration 0
TDD	Table A.2.3.1.1-1A		15	QPSK	1/5	75		≥ 1	UL-DL configuration 0
TDD	Table A.2.3.1.1-1A		20	QPSK	1/6	100		≥ 1	UL-DL configuration 0
TDD	Table A.2.3.1.1-1a		1.4	QPSK	1/3	6		-	UE UL category 0
TDD	Table A.2.3.1.1-1a		3	QPSK	1/5	15		-	UE UL category 0
TDD	Table A.2.3.1.1-1a		5	QPSK	1/8	25		-	UE UL category 0
TDD	Table A.2.3.1.1-1a		10	QPSK	1/10	36		-	UE UL category 0
-	Table A.2.3.1.1-1a		15	QPSK	1/10	36		-	UE UL category 0
TDD	Table A.2.3.1.1-1a		20	QPSK	1/10	36		-	UE UL category 0
TDD	Table A.2.3.1.1-1b		1.4	QPSK	1/3	6		-	UE UL category M1
TDD	Table A.2.3.1.1-1b		3	QPSK	1/3	6		-	UE UL category M1
TDD	Table A.2.3.1.1-1b		5	QPSK	1/3	6		-	UE UL category M1
TDD	Table A.2.3.1.1-1b		10	QPSK	1/3	6		-	UE UL category M1
TDD	Table A.2.3.1.1-1b		15	QPSK	1/3	6		-	UE UL category M1
TDD	Table A.2.3.1.1-1b		20	QPSK	1/3	6		-	UE UL category M1
TDD	Table A.2.3.1.1-1c		1.4	QPSK	1/3	6		-	UE UL category M2
TDD	Table A.2.3.1.1-1c		3	QPSK	1/3	12		-	UE UL category M2
TDD	Table A.2.3.1.1-1c		5	QPSK	1/3	24		-	UE UL category M2
TDD	Table A.2.3.1.1-1c		10	QPSK	1/3	24		-	UE UL category M2
TDD	Table A.2.3.1.1-1c		15	QPSK	1/3	24		-	UE UL category M2
TDD	Table A.2.3.1.1-1c		20	QPSK	1/3	24		-	UE UL category M2

Table A.2.1.3-1G: Overview of UL reference measurement channels (TDD, Full RB allocation, 16-QAM)

Duplex	Table	Name	BW	Mod	TCR	RB	RB Off set	UE Cat eg	Notes
TDD	Table A.2.3.1.2-1		1.4	16QAM	3/4	6		≥ 1	
TDD	Table A.2.3.1.2-1		3	16QAM	1/2	15		≥ 1	
TDD	Table A.2.3.1.2-1		5	16QAM	1/3	25		≥ 1	
TDD	Table A.2.3.1.2-1		10	16QAM	3/4	50		≥ 2	
TDD	Table A.2.3.1.2-1		15	16QAM	1/2	75		≥ 2	
TDD	Table A.2.3.1.2-1		20	16QAM	1/3	100		≥ 2	
TDD	Table A.2.3.1.2-1A		1.4	16QAM	3/4	6		≥ 1	UL-DL configuration 0
TDD	Table A.2.3.1.2-1A		3	16QAM	1/2	15		≥ 1	UL-DL configuration 0
TDD	Table A.2.3.1.2-1A		5	16QAM	1/3	25		≥ 1	UL-DL configuration 0
TDD	Table A.2.3.1.2-1A		10	16QAM	3/4	50		≥ 2	UL-DL configuration 0
TDD	Table A.2.3.1.2-1A		15	16QAM	1/2	75		≥ 2	UL-DL configuration 0
TDD	Table A.2.3.1.2-1A		20	16QAM	1/3	100		≥ 2	UL-DL configuration 0
TDD	Table A.2.3.1.2-1a		1.4	16QAM	1/3	5		-	UE UL category 0
TDD	Table A.2.3.1.2-1a		3	16QAM	1/3	5		-	UE UL category 0
TDD	Table A.2.3.1.2-1a		5	16QAM	1/3	5		-	UE UL category 0
TDD	Table A.2.3.1.2-1a		10	16QAM	1/3	5		-	UE UL category 0
TDD	Table A.2.3.1.2-1a		15	16QAM	1/3	5		-	UE UL category 0
TDD	Table A.2.3.1.2-1a		20	16QAM	1/3	5		-	UE UL category 0
TDD	Table A.2.3.1.1-1b		1.4	16QAM	1/3	5		-	UE UL category M1
TDD	Table A.2.3.1.1-1b		3	16QAM	1/3	5		-	UE UL category M1
TDD	Table A.2.3.1.1-1b		5	16QAM	1/3	5		-	UE UL category M1
TDD	Table A.2.3.1.1-1b		10	16QAM	1/3	5		-	UE UL category M1
TDD	Table A.2.3.1.1-1b		15	16QAM	1/3	5		-	UE UL category M1
TDD	Table A.2.3.1.1-1b		20	16QAM	1/3	5		-	UE UL category M1
TDD	Table A.2.3.1.1-1c		1.4	16QAM	1/3	6		-	UE UL category M2
TDD	Table A.2.3.1.1-1c		3	16QAM	1/3	12		-	UE UL category M2
TDD	Table A.2.3.1.1-1c		5	16QAM	1/3	24		-	UE UL category M2
TDD	Table A.2.3.1.1-1c		10	16QAM	1/3	24		-	UE UL category M2
TDD	Table A.2.3.1.1-1c		15	16QAM	1/3	24		-	UE UL category M2
TDD	Table A.2.3.1.1-1c		20	16QAM	1/3	24		-	UE UL category M2

Table A.2.1.3-1H: Overview of UL reference measurement channels (TDD, Full RB allocation, 64-QAM)

Duplex	Table	Name	BW	Mod	TCR	RB	RB Off set	UE Cat eg	Notes
TDD	Table A.2.3.1.3-1		1.4	64QAM	3/4	6		5,8	UL category 5, 8, 13, 14
TDD	Table A.2.3.1.3-1		3	64QAM	3/4	15		5,8	UL category 5, 8, 13, 14
TDD	Table A.2.3.1.3-1		5	64QAM	3/4	25		5,8	UL category 5, 8, 13, 14
TDD	Table A.2.3.1.3-1		10	64QAM	3/4	50		5,8	UL category 5, 8, 13, 14
TDD	Table A.2.3.1.3-1		15	64QAM	3/4	75		5,8	UL category 5, 8, 13, 14
TDD	Table A.2.3.1.3-1		20	64QAM	3/4	100		5,8	UL category 5, 8, 13, 14

**Table A.2.1.3-1Ha: Overview of UL reference measurement channels (TDD, Full RB allocation, 256-QAM)**

Duplex	Table	Name	BW	Mod	TCR	RB	RB Off set	UE Cat eg	Notes
TDD	Table A.2.3.1.4-1		1.4	256QAM	4/5	6			UL category $\geq 15$
TDD	Table A.2.3.1.4-1		3	256QAM	4/5	15			UL category $\geq 15$
TDD	Table A.2.3.1.4-1		5	256QAM	4/5	25			UL category $\geq 15$
TDD	Table A.2.3.1.4-1		10	256QAM	4/5	50			UL category $\geq 15$
TDD	Table A.2.3.1.4-1		15	256QAM	4/5	75			UL category $\geq 15$
TDD	Table A.2.3.1.4-1		20	256QAM	4/5	100			UL category $\geq 15$

**Table A.2.1.3-11: Overview of UL reference measurement channels (TDD, Partial RB allocation, QPSK)**

Duplex	Table	Name	BW	Mod	TCR	RB	RB Off set	UE Cat eg	Notes
TDD	Table A.2.3.2.1-1		1.4 - 20	QPSK	1/3	1		≥ 1	
TDD	Table A.2.3.2.1-1		1.4 - 20	QPSK	1/3	2		≥ 1	
TDD	Table A.2.3.2.1-1		1.4 - 20	QPSK	1/3	3		≥ 1	
TDD	Table A.2.3.2.1-1		1.4 - 20	QPSK	1/3	4		≥ 1	
TDD	Table A.2.3.2.1-1		1.4 - 20	QPSK	1/3	5		≥ 1	
TDD	Table A.2.3.2.1-1		3 - 20	QPSK	1/3	6		≥ 1	
TDD	Table A.2.3.2.1-1		3 - 20	QPSK	1/3	8		≥ 1	
TDD	Table A.2.3.2.1-1		3 - 20	QPSK	1/3	9		≥ 1	
TDD	Table A.2.3.2.1-1		3 - 20	QPSK	1/3	10		≥ 1	
TDD	Table A.2.3.2.1-1		3 - 20	QPSK	1/3	12		≥ 1	
TDD	Table A.2.3.2.1-1		5 - 20	QPSK	1/3	15		≥ 1	
TDD	Table A.2.3.2.1-1		5 - 20	QPSK	1/3	16		≥ 1	
TDD	Table A.2.3.2.1-1		5 - 20	QPSK	1/3	18		≥ 1	
TDD	Table A.2.3.2.1-1		5 - 20	QPSK	1/3	20		≥ 1	
TDD	Table A.2.3.2.1-1		5 - 20	QPSK	1/3	24		≥ 1	
TDD	Table A.2.3.2.1-1		10 - 20	QPSK	1/3	25		≥ 1	
TDD	Table A.2.3.2.1-1		10 - 20	QPSK	1/3	27		≥ 1	
TDD	Table A.2.3.2.1-1		10 - 20	QPSK	1/3	30		≥ 1	
TDD	Table A.2.3.2.1-1		10 - 20	QPSK	1/3	32		≥ 1	
TDD	Table A.2.3.2.1-1		10 - 20	QPSK	1/3	36		≥ 1	
TDD	Table A.2.3.2.1-1		10 - 20	QPSK	1/3	40		≥ 1	
TDD	Table A.2.3.2.1-1		10 - 20	QPSK	1/3	45		≥ 1	
TDD	Table A.2.3.2.1-1		10 - 20	QPSK	1/3	48		≥ 1	
TDD	Table A.2.3.2.1-1		15 - 20	QPSK	1/3	50		≥ 1	
TDD	Table A.2.3.2.1-1		15 - 20	QPSK	1/3	54		≥ 1	
TDD	Table A.2.3.2.1-1		15 - 20	QPSK	1/4	60		≥ 1	
TDD	Table A.2.3.2.1-1		15 - 20	QPSK	1/4	64		≥ 1	
TDD	Table A.2.3.2.1-1		15 - 20	QPSK	1/4	72		≥ 1	
TDD	Table A.2.3.2.1-1		20	QPSK	1/5	75		≥ 1	
TDD	Table A.2.3.2.1-1		20	QPSK	1/5	80		≥ 1	
TDD	Table A.2.3.2.1-1		20	QPSK	1/5	81		≥ 1	
TDD	Table A.2.3.2.1-1		20	QPSK	1/6	90		≥ 1	
TDD	Table A.2.3.2.1-1		20	QPSK	1/6	96		≥ 1	
TDD	Table A.2.3.2.1-1A		1.4 - 20	QPSK	1/3	1		≥ 1	UL-DL configuration 0
TDD	Table A.2.3.2.1-1A		1.4 - 20	QPSK	1/3	2		≥ 1	UL-DL configuration 0
TDD	Table A.2.3.2.1-1A		1.4 - 20	QPSK	1/3	3		≥ 1	UL-DL configuration 0
TDD	Table A.2.3.2.1-1A		1.4 - 20	QPSK	1/3	4		≥ 1	UL-DL configuration 0
TDD	Table A.2.3.2.1-1A		1.4 - 20	QPSK	1/3	5		≥ 1	UL-DL configuration 0
TDD	Table A.2.3.2.1-1A		3 - 20	QPSK	1/3	6		≥ 1	UL-DL configuration 0
TDD	Table A.2.3.2.1-1A		3 - 20	QPSK	1/3	8		≥ 1	UL-DL configuration 0
TDD	Table A.2.3.2.1-1A		3 - 20	QPSK	1/3	9		≥ 1	UL-DL configuration 0
TDD	Table A.2.3.2.1-1A		3 - 20	QPSK	1/3	10		≥ 1	UL-DL configuration 0
TDD	Table A.2.3.2.1-1A		3 - 20	QPSK	1/3	12		≥ 1	UL-DL configuration 0
TDD	Table A.2.3.2.1-1A		5 - 20	QPSK	1/3	15		≥ 1	UL-DL configuration 0
TDD	Table A.2.3.2.1-1A		5 - 20	QPSK	1/3	16		≥ 1	UL-DL configuration 0
TDD	Table A.2.3.2.1-1A		5 - 20	QPSK	1/3	18		≥ 1	UL-DL configuration 0

TDD	Table A.2.3.2.1-1A		5 - 20	QPSK	1/3	20		$\geq 1$	UL-DL configuration 0
TDD	Table A.2.3.2.1-1A		5 - 20	QPSK	1/3	24		$\geq 1$	UL-DL configuration 0
TDD	Table A.2.3.2.1-1A		10 - 20	QPSK	1/3	25		$\geq 1$	UL-DL configuration 0
TDD	Table A.2.3.2.1-1A		10 - 20	QPSK	1/3	27		$\geq 1$	UL-DL configuration 0
TDD	Table A.2.3.2.1-1A		10 - 20	QPSK	1/3	30		$\geq 1$	UL-DL configuration 0
TDD	Table A.2.3.2.1-1A		10 - 20	QPSK	1/3	32		$\geq 1$	UL-DL configuration 0
TDD	Table A.2.3.2.1-1A		10 - 20	QPSK	1/3	36		$\geq 1$	UL-DL configuration 0
TDD	Table A.2.3.2.1-1A		10 - 20	QPSK	1/3	40		$\geq 1$	UL-DL configuration 0
TDD	Table A.2.3.2.1-1A		10 - 20	QPSK	1/3	45		$\geq 1$	UL-DL configuration 0
TDD	Table A.2.3.2.1-1A		10 - 20	QPSK	1/3	48		$\geq 1$	UL-DL configuration 0
TDD	Table A.2.3.2.1-1A		15 - 20	QPSK	1/3	50		$\geq 1$	UL-DL configuration 0
TDD	Table A.2.3.2.1-1A		15 - 20	QPSK	1/3	54		$\geq 1$	UL-DL configuration 0
TDD	Table A.2.3.2.1-1A		15 - 20	QPSK	1/4	60		$\geq 1$	UL-DL configuration 0
TDD	Table A.2.3.2.1-1A		15 - 20	QPSK	1/4	64		$\geq 1$	UL-DL configuration 0
TDD	Table A.2.3.2.1-1A		15 - 20	QPSK	1/4	72		$\geq 1$	UL-DL configuration 0
TDD	Table A.2.3.2.1-1A		20	QPSK	1/5	75		$\geq 1$	UL-DL configuration 0
TDD	Table A.2.3.2.1-1A		20	QPSK	1/5	80		$\geq 1$	UL-DL configuration 0
TDD	Table A.2.3.2.1-1A		20	QPSK	1/5	81		$\geq 1$	UL-DL configuration 0
TDD	Table A.2.3.2.1-1A		20	QPSK	1/6	90		$\geq 1$	UL-DL configuration 0
TDD	Table A.2.3.2.1-1A		20	QPSK	1/6	96		$\geq 1$	UL-DL configuration 0
TDD	Table A.2.3.2.1-1a		1.4 - 20	QPSK	1/3	1		-	UE UL category 0
TDD	Table A.2.3.2.1-1a		1.4 - 20	QPSK	1/3	2		-	UE UL category 0
TDD	Table A.2.3.2.1-1a		1.4 - 20	QPSK	1/3	3		-	UE UL category 0
TDD	Table A.2.3.2.1-1a		1.4 - 20	QPSK	1/3	4		-	UE UL category 0
TDD	Table A.2.3.2.1-1a		1.4 - 20	QPSK	1/3	5		-	UE UL category 0
TDD	Table A.2.3.2.1-1a		3-20	QPSK	1/3	6		-	UE UL category 0
TDD	Table A.2.3.2.1-1a		3-20	QPSK	1/3	8		-	UE UL category 0
TDD	Table A.2.3.2.1-1a		3-20	QPSK	1/3	9		-	UE UL category 0
TDD	Table A.2.3.2.1-1a		3-20	QPSK	1/3	10		-	UE UL category 0
TDD	Table A.2.3.2.1-1a		3-20	QPSK	1/4	12		-	UE UL category 0
TDD	Table A.2.3.2.1-1a		5-20	QPSK	1/5	15		-	UE UL category 0
TDD	Table A.2.3.2.1-1a		5-20	QPSK	1/5	16		-	UE UL category 0
TDD	Table A.2.3.2.1-1a		5-20	QPSK	1/6	18		-	UE UL category 0
TDD	Table A.2.3.2.1-1a		5-20	QPSK	1/6	20		-	UE UL category 0
TDD	Table A.2.3.2.1-1a		5-20	QPSK	1/8	24		-	UE UL category 0
TDD	Table A.2.3.2.1-1a		10-20	QPSK	1/8	25		-	UE UL category 0
TDD	Table A.2.3.2.1-1a		10-20	QPSK	1/8	27		-	UE UL category 0
TDD	Table A.2.3.2.1-1a		10-20	QPSK	1/10	30		-	UE UL category 0
TDD	Table A.2.3.2.1-1b		1.4-20	QPSK	1/3	1		-	UE UL category M1
TDD	Table A.2.3.2.1-1b		1.4-20	QPSK	1/3	2		-	UE UL category M1
TDD	Table A.2.3.2.1-1b		1.4-20	QPSK	1/3	3		-	UE UL category M1
TDD	Table A.2.3.2.1-1b		1.4-20	QPSK	1/3	4		-	UE UL category M1
TDD	Table A.2.3.2.1-1b		1.4-20	QPSK	1/3	5		-	UE UL category M1
TDD	Table A.2.3.2.1-1b		3-20	QPSK	1/3	6		-	UE UL category M1
TDD	Table A.2.3.2.1-1c		1.4-20	QPSK	1/3	1		-	UE UL category M2
TDD	Table A.2.3.2.1-1c		1.4-20	QPSK	1/3	2		-	UE UL category M2
TDD	Table A.2.3.2.1-1c		1.4-20	QPSK	1/3	3		-	UE UL category M2
TDD	Table A.2.3.2.1-1c		1.4-20	QPSK	1/3	4		-	UE UL category M2

TDD	Table A.2.3.2.1-1c		1,4-20	QPSK	1/3	5		-	UE UL category M2
TDD	Table A.2.3.2.1-1c		3-20	QPSK	1/3	6		-	UE UL category M2
TDD	Table A.2.3.2.1-1c		3-20	QPSK	1/3	9		-	UE UL category M2
TDD	Table A.2.3.2.1-1c		3-20	QPSK	1/3	12		-	UE UL category M2
TDD	Table A.2.3.2.1-1c		5-20	QPSK	1/3	15		-	UE UL category M2
TDD	Table A.2.3.2.1-1c		5-20	QPSK	1/3	18		-	UE UL category M2
TDD	Table A.2.3.2.1-1c		5-20	QPSK	1/3	21		-	UE UL category M2



**Table A.2.1.3-1J: Overview of UL reference measurement channels (TDD, Partial RB allocation, 16-QAM)**

Duplex	Table	Name	BW	Mod	TCR	RB	RB Off set	UE Cat eg	Notes
TDD	Table A.2.3.2.2-1		1.4 - 20	16QAM	3/4	1		≥ 1	
TDD	Table A.2.3.2.2-1		1.4 - 20	16QAM	3/4	2		≥ 1	
TDD	Table A.2.3.2.2-1		1.4 - 20	16QAM	3/4	3		≥ 1	
TDD	Table A.2.3.2.2-1		1.4 - 20	16QAM	3/4	4		≥ 1	
TDD	Table A.2.3.2.2-1		1.4 - 20	16QAM	3/4	5		≥ 1	
TDD	Table A.2.3.2.2-1		3 - 20	16QAM	3/4	6		≥ 1	
TDD	Table A.2.3.2.2-1		3 - 20	16QAM	3/4	8		≥ 1	
TDD	Table A.2.3.2.2-1		3 - 20	16QAM	3/4	9		≥ 1	
TDD	Table A.2.3.2.2-1		3 - 20	16QAM	3/4	10		≥ 1	
TDD	Table A.2.3.2.2-1		3 - 20	16QAM	3/4	12		≥ 1	
TDD	Table A.2.3.2.2-1		5 - 20	16QAM	1/2	15		≥ 1	
TDD	Table A.2.3.2.2-1		5 - 20	16QAM	1/2	16		≥ 1	
TDD	Table A.2.3.2.2-1		5 - 20	16QAM	1/2	18		≥ 1	
TDD	Table A.2.3.2.2-1		5 - 20	16QAM	1/3	20		≥ 1	
TDD	Table A.2.3.2.2-1		5 - 20	16QAM	1/3	24		≥ 1	
TDD	Table A.2.3.2.2-1		10 - 20	16QAM	1/3	25		≥ 1	
TDD	Table A.2.3.2.2-1		10 - 20	16QAM	1/3	27		≥ 1	
TDD	Table A.2.3.2.2-1		10 - 20	16QAM	3/4	30		≥ 2	
TDD	Table A.2.3.2.2-1		10 - 20	16QAM	3/4	32		≥ 2	
TDD	Table A.2.3.2.2-1		10 - 20	16QAM	3/4	36		≥ 2	
TDD	Table A.2.3.2.2-1		10 - 20	16QAM	3/4	40		≥ 2	
TDD	Table A.2.3.2.2-1		10 - 20	16QAM	3/4	45		≥ 2	
TDD	Table A.2.3.2.2-1		10 - 20	16QAM	3/4	48		≥ 2	
TDD	Table A.2.3.2.2-1		15 - 20	16QAM	3/4	50		≥ 2	
TDD	Table A.2.3.2.2-1		15 - 20	16QAM	3/4	54		≥ 2	
TDD	Table A.2.3.2.2-1		15 - 20	16QAM	2/3	60		≥ 2	
TDD	Table A.2.3.2.2-1		15 - 20	16QAM	2/3	64		≥ 2	
TDD	Table A.2.3.2.2-1		15 - 20	16QAM	1/2	72		≥ 2	
TDD	Table A.2.3.2.2-1		20	16QAM	1/2	75		≥ 2	
TDD	Table A.2.3.2.2-1		20	16QAM	1/2	80		≥ 2	
TDD	Table A.2.3.2.2-1		20	16QAM	1/2	81		≥ 2	
TDD	Table A.2.3.2.2-1		20	16QAM	2/5	90		≥ 2	
TDD	Table A.2.3.2.2-1		20	16QAM	2/5	96		≥ 2	
TDD	Table A.2.3.2.2-1A		1.4 - 20	16QAM	3/4	1		≥ 1	UL-DL configuration 0
TDD	Table A.2.3.2.2-1A		1.4 - 20	16QAM	3/4	2		≥ 1	UL-DL configuration 0
TDD	Table A.2.3.2.2-1A		1.4 - 20	16QAM	3/4	3		≥ 1	UL-DL configuration 0
TDD	Table A.2.3.2.2-1A		1.4 - 20	16QAM	3/4	4		≥ 1	UL-DL configuration 0
TDD	Table A.2.3.2.2-1A		1.4 - 20	16QAM	3/4	5		≥ 1	UL-DL configuration 0
TDD	Table A.2.3.2.2-1A		3 - 20	16QAM	3/4	6		≥ 1	UL-DL configuration 0
TDD	Table A.2.3.2.2-1A		3 - 20	16QAM	3/4	8		≥ 1	UL-DL configuration 0
TDD	Table A.2.3.2.2-1A		3 - 20	16QAM	3/4	9		≥ 1	UL-DL configuration 0
TDD	Table A.2.3.2.2-1A		3 - 20	16QAM	3/4	10		≥ 1	UL-DL configuration 0
TDD	Table A.2.3.2.2-1A		3 - 20	16QAM	3/4	12		≥ 1	UL-DL configuration 0
TDD	Table A.2.3.2.2-1A		5 - 20	16QAM	1/2	15		≥ 1	UL-DL configuration 0
TDD	Table A.2.3.2.2-1A		5 - 20	16QAM	1/2	16		≥ 1	UL-DL configuration 0
TDD	Table A.2.3.2.2-1A		5 - 20	16QAM	1/2	18		≥ 1	UL-DL configuration 0

TDD	Table A.2.3.2.2-1A		5 - 20	16QAM	1/3	20		$\geq 1$	UL-DL configuration 0
TDD	Table A.2.3.2.2-1A		5 - 20	16QAM	1/3	24		$\geq 1$	UL-DL configuration 0
TDD	Table A.2.3.2.2-1A		10 - 20	16QAM	1/3	25		$\geq 1$	UL-DL configuration 0
TDD	Table A.2.3.2.2-1A		10 - 20	16QAM	1/3	27		$\geq 1$	UL-DL configuration 0
TDD	Table A.2.3.2.2-1A		10 - 20	16QAM	3/4	30		$\geq 2$	UL-DL configuration 0
TDD	Table A.2.3.2.2-1A		10 - 20	16QAM	3/4	32		$\geq 2$	UL-DL configuration 0
TDD	Table A.2.3.2.2-1A		10 - 20	16QAM	3/4	36		$\geq 2$	UL-DL configuration 0
TDD	Table A.2.3.2.2-1A		10 - 20	16QAM	3/4	40		$\geq 2$	UL-DL configuration 0
TDD	Table A.2.3.2.2-1A		10 - 20	16QAM	3/4	45		$\geq 2$	UL-DL configuration 0
TDD	Table A.2.3.2.2-1A		10 - 20	16QAM	3/4	48		$\geq 2$	UL-DL configuration 0
TDD	Table A.2.3.2.2-1A		15 - 20	16QAM	3/4	50		$\geq 2$	UL-DL configuration 0
TDD	Table A.2.3.2.2-1A		15 - 20	16QAM	3/4	54		$\geq 2$	UL-DL configuration 0
TDD	Table A.2.3.2.2-1A		15 - 20	16QAM	2/3	60		$\geq 2$	UL-DL configuration 0
TDD	Table A.2.3.2.2-1A		15 - 20	16QAM	2/3	64		$\geq 2$	UL-DL configuration 0
TDD	Table A.2.3.2.2-1A		15 - 20	16QAM	1/2	72		$\geq 2$	UL-DL configuration 0
TDD	Table A.2.3.2.2-1A		20	16QAM	1/2	75		$\geq 2$	UL-DL configuration 0
TDD	Table A.2.3.2.2-1A		20	16QAM	1/2	80		$\geq 2$	UL-DL configuration 0
TDD	Table A.2.3.2.2-1A		20	16QAM	1/2	81		$\geq 2$	UL-DL configuration 0
TDD	Table A.2.3.2.2-1A		20	16QAM	2/5	90		$\geq 2$	UL-DL configuration 0
TDD	Table A.2.3.2.2-1A		20	16QAM	2/5	96		$\geq 2$	UL-DL configuration 0
TDD	Table A.2.3.2.2-1a		1.4 - 20	16QAM	3/4	1		-	UE UL category 0
TDD	Table A.2.3.2.2-1a		1.4 - 20	16QAM	3/4	2		-	UE UL category 0
TDD	Table A.2.3.2.2-1a		1.4 - 20	16QAM	2/5	4		-	UE UL category 0
TDD	Table A.2.3.2.2-1b		1.4 - 20	16QAM	3/4	1		-	UE UL category M1
TDD	Table A.2.3.2.2-1b		1.4 - 20	16QAM	3/4	2		-	UE UL category M1
TDD	Table A.2.3.2.2-1b		1.4 - 20	16QAM	2/5	4		-	UE UL category M1
TDD	Table A.2.3.2.2-1c		1.4 - 20	16QAM	1/2	1		-	UE UL category M2
TDD	Table A.2.3.2.2-1c		1.4 - 20	16QAM	1/2	2		-	UE UL category M2
TDD	Table A.2.3.2.2-1c		1.4 - 20	16QAM	1/2	3		-	UE UL category M2
TDD	Table A.2.3.2.2-1c		1.4 - 20	16QAM	1/2	4		-	UE UL category M2
TDD	Table A.2.3.2.2-1c		1.4 - 20	16QAM	1/2	5		-	UE UL category M2
TDD	Table A.2.3.2.2-1c		3 - 20	16QAM	1/2	6		-	UE UL category M2
TDD	Table A.2.3.2.2-1c		3 - 20	16QAM	1/2	9		-	UE UL category M2
TDD	Table A.2.3.2.2-1c		3 - 20	16QAM	1/2	12		-	UE UL category M2
TDD	Table A.2.3.2.2-1c		5 - 20	16QAM	1/2	15		-	UE UL category M2
TDD	Table A.2.3.2.2-1c		5 - 20	16QAM	1/2	18		-	UE UL category M2
TDD	Table A.2.3.2.2-1c		5 - 20	16QAM	1/2	21		-	UE UL category M2
TDD	Table A.2.3.2.2-1c		5 - 20	16QAM	1/2	24		-	UE UL category M2

**Table A.2.1.3-1K: Overview of UL reference measurement channels (TDD, Partial RB allocation, 64-QAM)**

Duplex	Table	Name	BW	Mod	TCR	RB	RB Off set	UE Cat eg	Notes
TDD	Table A.2.3.2.3-1		1.4 - 20	64QAM	3/4	1		5,8	UL category 5, 8, 13, 14
TDD	Table A.2.3.2.3-1		1.4 - 20	64QAM	3/4	2		5,8	UL category 5, 8, 13, 14
TDD	Table A.2.3.2.3-1		1.4 - 20	64QAM	3/4	3		5,8	UL category 5, 8, 13, 14
TDD	Table A.2.3.2.3-1		1.4 - 20	64QAM	3/4	4		5,8	UL category 5, 8, 13, 14
TDD	Table A.2.3.2.3-1		1.4 - 20	64QAM	3/4	5		5,8	UL category 5, 8, 13, 14
TDD	Table A.2.3.2.3-1		3 - 20	64QAM	3/4	6		5,8	UL category 5, 8, 13, 14
TDD	Table A.2.3.2.3-1		3 - 20	64QAM	3/4	8		5,8	UL category 5, 8, 13, 14
TDD	Table A.2.3.2.3-1		3 - 20	64QAM	3/4	9		5,8	UL category 5, 8, 13, 14
TDD	Table A.2.3.2.3-1		3 - 20	64QAM	3/4	10		5,8	UL category 5, 8, 13, 14
TDD	Table A.2.3.2.3-1		3 - 20	64QAM	3/4	12		5,8	UL category 5, 8, 13, 14
TDD	Table A.2.3.2.3-1		5 - 20	64QAM	3/4	15		5,8	UL category 5, 8, 13, 14
TDD	Table A.2.3.2.3-1		5 - 20	64QAM	3/4	16		5,8	UL category 5, 8, 13, 14
TDD	Table A.2.3.2.3-1		5 - 20	64QAM	3/4	18		5,8	UL category 5, 8, 13, 14
TDD	Table A.2.3.2.3-1		5 - 20	64QAM	3/4	20		5,8	UL category 5, 8, 13, 14
TDD	Table A.2.3.2.3-1		5 - 20	64QAM	3/4	24		5,8	UL category 5, 8, 13, 14
TDD	Table A.2.3.2.3-1		10 - 20	64QAM	3/4	25		5,8	UL category 5, 8, 13, 14
TDD	Table A.2.3.2.3-1		10 - 20	64QAM	3/4	27		5,8	UL category 5, 8, 13, 14
TDD	Table A.2.3.2.3-1		10 - 20	64QAM	3/4	30		5,8	UL category 5, 8, 13, 14
TDD	Table A.2.3.2.3-1		10 - 20	64QAM	3/4	32		5,8	UL category 5, 8, 13, 14
TDD	Table A.2.3.2.3-1		10 - 20	64QAM	3/4	36		5,8	UL category 5, 8, 13, 14
TDD	Table A.2.3.2.3-1		10 - 20	64QAM	3/4	40		5,8	UL category 5, 8, 13, 14
TDD	Table A.2.3.2.3-1		10 - 20	64QAM	3/4	45		5,8	UL category 5, 8, 13, 14
TDD	Table A.2.3.2.3-1		10 - 20	64QAM	3/4	48		5,8	UL category 5, 8, 13, 14
TDD	Table A.2.3.2.3-1		15 - 20	64QAM	3/4	50		5,8	UL category 5, 8, 13, 14
TDD	Table A.2.3.2.3-1		15 - 20	64QAM	3/4	54		5,8	UL category 5, 8, 13, 14
TDD	Table A.2.3.2.3-1		15 - 20	64QAM	3/4	60		5,8	UL category 5, 8, 13, 14
TDD	Table A.2.3.2.3-1		15 - 20	64QAM	3/4	64		5,8	UL category 5, 8, 13, 14
TDD	Table A.2.3.2.3-1		15 - 20	64QAM	3/4	72		5,8	UL category 5, 8, 13, 14
TDD	Table A.2.3.2.3-1		20	64QAM	3/4	75		5,8	UL category 5, 8, 13, 14
TDD	Table A.2.3.2.3-1		20	64QAM	3/4	80		5,8	UL category 5, 8, 13, 14
TDD	Table A.2.3.2.3-1		20	64QAM	3/4	81		5,8	UL category 5, 8, 13, 14
TDD	Table A.2.3.2.3-1		20	64QAM	3/4	90		5,8	UL category 5, 8, 13, 14
TDD	Table A.2.3.2.3-1		20	64QAM	3/4	96		5,8	UL category 5, 8, 13, 14

**Table A.2.1.3-1Ka: Overview of UL reference measurement channels (TDD, Partial RB allocation, 256-QAM)**

ETSI

Duplex	Table	Name	BW	Mod	TCR	RB	RB Off set	UE Cat eg	Notes
TDD	Table A.2.3.2.4-1		1.4 - 20	256QAM	4/5	1			UL category $\geq$ 15
TDD	Table A.2.3.2.4-1		1.4 - 20	256QAM	4/5	2			UL category $\geq$ 15
TDD	Table A.2.3.2.4-1		1.4 - 20	256QAM	4/5	3			UL category $\geq$ 15
TDD	Table A.2.3.2.4-1		1.4 - 20	256QAM	4/5	4			UL category $\geq$ 15
TDD	Table A.2.3.2.4-1		1.4 - 20	256QAM	4/5	5			UL category $\geq$ 15
TDD	Table A.2.3.2.4-1		3 - 20	256QAM	4/5	6			UL category $\geq$ 15
TDD	Table A.2.3.2.4-1		3 - 20	256QAM	4/5	8			UL category $\geq$ 15
TDD	Table A.2.3.2.4-1		3 - 20	256QAM	4/5	9			UL category $\geq$ 15
TDD	Table A.2.3.2.4-1		3 - 20	256QAM	4/5	10			UL category $\geq$ 15
TDD	Table A.2.3.2.4-1		3 - 20	256QAM	4/5	12			UL category $\geq$ 15
TDD	Table A.2.3.2.4-1		5 - 20	256QAM	4/5	15			UL category $\geq$ 15
TDD	Table A.2.3.2.4-1		5 - 20	256QAM	4/5	16			UL category $\geq$ 15
TDD	Table A.2.3.2.4-1		5 - 20	256QAM	4/5	18			UL category $\geq$ 15
TDD	Table A.2.3.2.4-1		5 - 20	256QAM	4/5	20			UL category $\geq$ 15
TDD	Table A.2.3.2.4-1		5 - 20	256QAM	4/5	24			UL category $\geq$ 15
TDD	Table A.2.3.2.4-1		10 - 20	256QAM	4/5	25			UL category $\geq$ 15
TDD	Table A.2.3.2.4-1		10 - 20	256QAM	4/5	27			UL category $\geq$ 15
TDD	Table A.2.3.2.4-1		10 - 20	256QAM	4/5	30			UL category $\geq$ 15
TDD	Table A.2.3.2.4-1		10 - 20	256QAM	4/5	32			UL category $\geq$ 15
TDD	Table A.2.3.2.4-1		10 - 20	256QAM	4/5	36			UL category $\geq$ 15
TDD	Table A.2.3.2.4-1		10 - 20	256QAM	4/5	40			UL category $\geq$ 15
TDD	Table A.2.3.2.4-1		10 - 20	256QAM	4/5	45			UL category $\geq$ 15
TDD	Table A.2.3.2.4-1		10 - 20	256QAM	4/5	48			UL category $\geq$ 15
TDD	Table A.2.3.2.4-1		15 - 20	256QAM	4/5	50			UL category $\geq$ 15
TDD	Table A.2.3.2.4-1		15 - 20	256QAM	4/5	54			UL category $\geq$ 15
TDD	Table A.2.3.2.4-1		15 - 20	256QAM	4/5	60			UL category $\geq$ 15
TDD	Table A.2.3.2.4-1		15 - 20	256QAM	4/5	64			UL category $\geq$ 15
TDD	Table A.2.3.2.4-1		15 - 20	256QAM	4/5	72			UL category $\geq$ 15
TDD	Table A.2.3.2.4-1		20	256QAM	4/5	75			UL category $\geq$ 15
TDD	Table A.2.3.2.4-1		20	256QAM	4/5	80			UL category $\geq$ 15
TDD	Table A.2.3.2.4-1		20	256QAM	4/5	81			UL category $\geq$ 15
TDD	Table A.2.3.2.4-1		20	256QAM	4/5	90			UL category $\geq$ 15
TDD	Table A.2.3.2.4-1		20	256QAM	4/5	96			UL category $\geq$ 15

**Table A.2.1.3-1L: Overview of UL reference measurement channels (HD-FDD, NB-IoT, QPSK)**

Duplex	Table	Name	BW	Mod	TCR	RB	RB Off set	UE Cat eg	Notes
HD-FDD	Table A.2.4-1		0.2	$\pi/2$ BPSK	1/3	1		NB1	
HD-FDD	Table A.2.4-1		0.2	$\pi/4$ QPSK	1/3	1		NB1	
HD-FDD	Table A.2.4-1		0.2	$\pi/2$ BPSK	1/3	1		NB1	
HD-FDD	Table A.2.4-1		0.2	$\pi/4$ QPSK	1/3	1		NB1	
HD-FDD	Table A.2.4-1		0.2	QPSK	1/3	1		NB1	
HD-FDD	Table A.2.4-1		0.2	QPSK	1/3	1		NB1	
HD-FDD	Table A.2.4-1		0.2	QPSK	1/3	1		NB1	

## A.2.2 Reference measurement channels for FDD

### A.2.2.1 Full RB allocation

#### A.2.2.1.1 QPSK

**Table A.2.2.1.1-1: Reference Channels for QPSK with full RB allocation**

Parameter	Unit	Value					
		1.4	3	5	10	15	20
Channel bandwidth	MHz	1.4	3	5	10	15	20
Allocated resource blocks		6	15	25	50	75	100
DFT-OFDM Symbols per Sub-Frame		12	12	12	12	12	12
Modulation		QPSK	QPSK	QPSK	QPSK	QPSK	QPSK
Target Coding rate		1/3	1/3	1/3	1/3	1/5	1/6
Payload size	Bits	600	1544	2216	5160	4392	4584
Transport block CRC	Bits	24	24	24	24	24	24
Number of code blocks per Sub-Frame (Note 1)		1	1	1	1	1	1
Total number of bits per Sub-Frame	Bits	1728	4320	7200	14400	21600	28800
Total symbols per Sub-Frame		864	2160	3600	7200	10800	14400
UE Category		$\geq 1$	$\geq 1$	$\geq 1$	$\geq 1$	$\geq 1$	$\geq 1$

Note 1: If more than one Code Block is present, an additional CRC sequence of L = 24 Bits is attached to each Code Block (otherwise L = 0 Bit)

**Table A.2.2.1.1-1a: Reference Channels for QPSK with full/maximum RB allocation for UE UL category 0**

Parameter	Unit	Value					
		1.4	3	5	10	15	20
Channel bandwidth	MHz	1.4	3	5	10	15	20
Allocated resource blocks		6	15	25	36	36	36
DFT-OFDM Symbols per Sub-Frame		12	12	12	12	12	12
Modulation		QPSK	QPSK	QPSK	QPSK	QPSK	QPSK
Target Coding rate		1/3	1/5	1/8	1/10	1/10	1/10
Payload size	Bits	600	872	904	1000	1000	1000
Transport block CRC	Bits	24	24	24	24	24	24
Number of code blocks per Sub-Frame (NOTE 1)		1	1	1	1	1	1
Total number of bits per Sub-Frame	Bits	1728	4320	7200	10368	10368	10368
Total symbols per Sub-Frame		864	2160	3600	5184	5184	5184
UE UL Category		0	0	0	0	0	0
NOTE 1: If more than one Code Block is present, an additional CRC sequence of L = 24 Bits is attached to each Code Block (otherwise L = 0 Bit)							
NOTE 2: For HD-FDD UE, the uplink subframes are scheduled at the 4th, 5th, 6th, 12th, 13th, 14th, 20th, 21st, 22nd, 28th, 29th, 30th, 36th, 37th, and 38th subframes every 40ms. Information bit payload is available if uplink subframe is scheduled.							

**Table A.2.2.1.1-1b: Reference Channels for QPSK with full/maximum RB allocation for UE UL category M1**

Parameter	Unit	Value					
		1.4	3	5	10	15	20
Channel bandwidth	MHz	1.4	3	5	10	15	20
Allocated resource blocks		6	6	6	6	6	6
DFT-OFDM Symbols per Sub-Frame		12	12	12	12	12	12
Modulation		QPSK	QPSK	QPSK	QPSK	QPSK	QPSK
Target Coding rate		1/3	1/3	1/3	1/3	1/3	1/3
Payload size	Bits	600	600	600	600	600	600
Transport block CRC	Bits	24	24	24	24	24	24
Number of code blocks per Sub-Frame (NOTE 1)		1	1	1	1	1	1
Total number of bits per Sub-Frame	Bits	1728	1728	1728	1728	1728	1728
Total symbols per Sub-Frame		864	864	864	864	864	864
UE UL Category		M1	M1	M1	M1	M1	M1
NOTE 1: If more than one Code Block is present, an additional CRC sequence of L = 24 Bits is attached to each Code Block (otherwise L = 0 Bit)							
NOTE 2: For HD-FDD UE with $N_{abs}^{PUSCH} = 1$ , the uplink subframes are scheduled at the 4th, 5th and 6th subframes every 10ms for the channel bandwidth 5MHz/10MHz/15MHz/20MHz. For HD-FDD UE, the uplink subframes are scheduled at the 5th, 6th and 7th subframes every 10ms for the channel bandwidth 1.4MHz/3MHz. Information bit payload is available if uplink subframe is scheduled. $N_{abs}^{PUSCH}$ is total number of absolute subframes a PUSCH with repetition spans [4].							
NOTE 3: For HD-FDD UE with $N_{abs}^{PUSCH} > 1$ , MPDCCH are scheduled at 0th DL subframe every $N_{abs}^{PUSCH} + 5$ subframes (starting from the 0th subframe). The associated PUSCH is scheduled at the 4th to $(N_{abs}^{PUSCH} + 3)$ -th UL subframes every $N_{abs}^{PUSCH} + 5$ subframes. Information bit payload is available if uplink subframe is scheduled.							

**Table A.2.2.1.1-1c: Reference Channels for QPSK with full/maximum RB allocation for UE UL category M2**

Parameter	Unit	Value					
		1.4	3	5	10	15	20
Channel bandwidth	MHz	1.4	3	5	10	15	20
Allocated resource blocks		6	12	24	24	24	24
DFT-OFDM Symbols per Sub-Frame		12	12	12	12	12	12
Modulation		QPSK	QPSK	QPSK	QPSK	QPSK	QPSK
Target Coding rate		1/3	1/3	1/3	1/3	1/3	1/3
Payload size	Bits	600	1224	2472	2472	2472	2472
Transport block CRC	Bits	24	24	24	24	24	24
Number of code blocks per Sub-Frame (NOTE 1)		1	1	1	1	1	1
Total number of bits per Sub-Frame	Bits	1728	3456	6912	6912	6912	6912
Total symbols per Sub-Frame		864	1728	3456	3456	3456	3456
UE UL Category		M2	M2	M2	M2	M2	M2
NOTE 1: If more than one Code Block is present, an additional CRC sequence of L = 24 Bits is attached to each Code Block (otherwise L = 0 Bit)							
NOTE 2: For HD-FDD UE, the uplink subframes are scheduled at the 4th, 5th and 6th subframes every 10ms for the channel bandwidth 5MHz/10MHz/15MHz/20MHz. For HD-FDD UE, the uplink subframes are scheduled at the 5th, 6th and 7th subframes every 10ms for the channel bandwidth 1.4MHz/3MHz. Information bit payload is available if uplink subframe is scheduled.							

## A.2.2.1.2 16-QAM

**Table A.2.2.1.2-1: Reference Channels for 16-QAM with full RB allocation**

Parameter	Unit	Value					
		1.4	3	5	10	15	20
Channel bandwidth	MHz	1.4	3	5	10	15	20
Allocated resource blocks		6	15	25	50	75	100
DFT-OFDM Symbols per Sub-Frame		12	12	12	12	12	12
Modulation		16QAM	16QAM	16QAM	16QAM	16QAM	16QAM
Target Coding rate		3/4	1/2	1/3	3/4	1/2	1/3
Payload size	Bits	2600	4264	4968	21384	21384	19848
Transport block CRC	Bits	24	24	24	24	24	24
Number of code blocks per Sub-Frame (Note 1)		1	1	1	4	4	4
Total number of bits per Sub-Frame	Bits	3456	8640	14400	28800	43200	57600
Total symbols per Sub-Frame		864	2160	3600	7200	10800	14400
UE Category		≥ 1	≥ 1	≥ 1	≥ 2	≥ 2	≥ 2
Note 1: If more than one Code Block is present, an additional CRC sequence of L = 24 Bits is attached to each Code Block (otherwise L = 0 Bit)							



**Table A.2.2.1.2-1a: Reference Channels for 16-QAM with maximum RB allocation for UE UL category 0**

Parameter	Unit	Value					
		1.4	3	5	10	15	20
Channel bandwidth	MHz	1.4	3	5	10	15	20
Allocated resource blocks		5	5	5	5	5	5
DFT-OFDM Symbols per Sub-Frame		12	12	12	12	12	12
Modulation		16QAM	16QAM	16QAM	16QAM	16QAM	16QAM
Target Coding rate		1/3	1/3	1/3	1/3	1/3	1/3
Payload size	Bits	872	872	872	872	872	872
Transport block CRC	Bits	24	24	24	24	24	24
Number of code blocks per Sub-Frame		1	1	1	1	1	1
Total number of bits per Sub-Frame	Bits	2880	2880	2880	2880	2880	2880
Total symbols per Sub-Frame		720	720	720	720	720	720
UE UL Category		0	0	0	0	0	0

NOTE 1: If more than one Code Block is present, an additional CRC sequence of L = 24 Bits is attached to each Code Block (otherwise L = 0 Bit)

NOTE 2: For HD-FDD UE, the uplink subframes are scheduled at the 4th, 5th, 6th, 12th, 13th, 14th, 20th, 21st, 22nd, 28th, 29th, 30th, 36th, 37th, and 38th subframes every 40ms. Information bit payload is available if uplink subframe is scheduled.

**Table A.2.2.1.2-1b: Reference Channels for 16-QAM with maximum RB allocation for UE UL category M1**

Parameter	Unit	Value					
		1.4	3	5	10	15	20
Channel bandwidth	MHz	1.4	3	5	10	15	20
Allocated resource blocks		5	5	5	5	5	5
DFT-OFDM Symbols per Sub-Frame		12	12	12	12	12	12
Modulation		16QAM	16QAM	16QAM	16QAM	16QAM	16QAM
Target Coding rate		1/3	1/3	1/3	1/3	1/3	1/3
Payload size	Bits	872	872	872	872	872	872
Transport block CRC	Bits	24	24	24	24	24	24
Number of code blocks per Sub-Frame		1	1	1	1	1	1
Total number of bits per Sub-Frame	Bits	2880	2880	2880	2880	2880	2880
Total symbols per Sub-Frame		720	720	720	720	720	720
UE Category		M1	M1	M1	M1	M1	M1

NOTE 1: If more than one Code Block is present, an additional CRC sequence of L = 24 Bits is attached to each Code Block (otherwise L = 0 Bit).

NOTE 2: For HD-FDD UE, the uplink subframes are scheduled at the 4th, 5th and 6th subframes every 10ms for the channel bandwidth 5MHz/10MHz/15MHz/20MHz. For HD-FDD UE, the uplink subframes are scheduled at the 5th, 6th and 7th subframes every 10ms for the channel bandwidth 1.4MHz/3MHz. Information bit payload is available if uplink subframe is scheduled.

**Table A.2.2.1.2-1c: Reference Channels for 16-QAM with maximum RB allocation for UE UL category M2**

Parameter	Unit	Value					
		1.4	3	5	10	15	20
Channel bandwidth	MHz	1.4	3	5	10	15	20
Allocated resource blocks		6	12	24	24	24	24
DFT-OFDM Symbols per Sub-Frame		12	12	12	12	12	12
Modulation		16QAM	16QAM	16QAM	16QAM	16QAM	16QAM
Target Coding rate		1/3	1/3	1/3	1/3	1/3	1/3
Payload size	Bits	1032	2088	4264	4264	4264	4264
Transport block CRC	Bits	24	24	24	24	24	24
Number of code blocks per Sub-Frame		1	1	1	1	1	1
Total number of bits per Sub-Frame	Bits	3456	6912	13824	13824	13824	13824
Total symbols per Sub-Frame		864	1728	3456	3456	3456	3456
UE Category		M2	M2	M2	M2	M2	M2

NOTE 1: If more than one Code Block is present, an additional CRC sequence of L = 24 Bits is attached to each Code Block (otherwise L = 0 Bit).

NOTE 2: For HD-FDD UE, the uplink subframes are scheduled at the 4th, 5th and 6th subframes every 10ms for the channel bandwidth 5MHz/10MHz/15MHz/20MHz. For HD-FDD UE, the uplink subframes are scheduled at the 5th, 6th and 7th subframes every 10ms for the channel bandwidth 1.4MHz/3MHz. Information bit payload is available if uplink subframe is scheduled.

**A.2.2.1.3 64-QAM****Table A.2.2.1.3-1: Reference Channels for 64-QAM with full RB allocation**

Parameter	Unit	Value					
		1.4	3	5	10	15	20
Channel bandwidth	MHz	1.4	3	5	10	15	20
Allocated resource blocks		6	15	25	50	75	100
DFT-OFDM Symbols per Sub-Frame		12	12	12	12	12	12
Modulation		64QAM	64QAM	64QAM	64QAM	64QAM	64QAM
Target Coding rate		3/4	3/4	3/4	3/4	3/4	3/4
Payload size	Bits	3752	9528	15840	31704	46888	63776
Transport block CRC	Bits	24	24	24	24	24	24
Number of code blocks per Sub-Frame (Note 1)		1	2	3	6	8	11
Total number of bits per Sub-Frame	Bits	5184	12960	21600	43200	64800	86400
Total symbols per Sub-Frame		864	2160	3600	7200	10800	14400
UE Category (Note 2)		5, 8	5, 8	5, 8	5, 8	5, 8	5, 8
UE UL Category (Note 2)		5, 8, 13, 14	5, 8, 13, 14	5, 8, 13, 14	5, 8, 13, 14	5, 8, 13, 14	5, 8, 13, 14

Note 1: If more than one Code Block is present, an additional CRC sequence of L = 24 Bits is attached to each Code Block (otherwise L = 0 Bit)

Note 2: If UE does not report UE UL category, then the applicability of reference channel is determined by UE category. If UE reports UE UL category, then the applicability of reference channel is determined by UE UL category.

## A.2.2.1.4 256 QAM

Table A.2.2.1.4-1: Reference Channels for 256 QAM with full RB allocation

Parameter	Unit	Value					
		1.4	3	5	10	15	20
Channel bandwidth	MHz	1.4	3	5	10	15	20
Allocated resource blocks		6	15	25	50	75	100
DFT-OFDM Symbols per Sub-Frame		12	12	12	12	12	12
Modulation		256QAM	256QAM	256QAM	256QAM	256QAM	256QAM
Target Coding rate		3/4	3/4	3/4	3/4	3/4	3/4
Payload size	Bits	5160	12960	21384	42368	63776	84760
Transport block CRC	Bits	24	24	24	24	24	24
Number of code blocks per Sub-Frame (Note 1)		1	3	4	8	11	15
Total number of bits per Sub-Frame	Bits	6912	17280	28800	57600	86400	115200
Total symbols per Sub-Frame		864	2160	3600	7200	10800	14400
UE UL Category		≥ 15	≥ 15	≥ 15	≥ 15	≥ 15	≥ 15
Note 1: If more than one Code Block is present, an additional CRC sequence of L = 24 Bits is attached to each Code Block (otherwise L = 0 Bit)							

## A.2.2.2 Partial RB allocation

For each channel bandwidth, various partial RB allocations are specified. The number of allocated RBs is chosen according to values specified in the Tx and Rx requirements. The single allocated RB case is included.

The allocated RBs are contiguous and start from one end of the channel bandwidth. A single allocated RB is at one end of the channel bandwidth.

## A.2.2.2.1 QPSK

Table A.2.2.2.1-1: Reference Channels for QPSK with partial RB allocation

Parameter	Ch BW	Allocated RBs	DFT-OFDM Symbols per Sub-Frame	Mod'n	Target Coding rate	Payload size	Transport block CRC	Number of code blocks per Sub-Frame (Note 1)	Total number of bits per Sub-Frame	Total symbols per Sub-Frame	UE Category
Unit	MHz					Bits	Bits		Bits		
	1.4 - 20	1	12	QPSK	1/3	72	24	1	288	144	≥ 1
	1.4 - 20	2	12	QPSK	1/3	176	24	1	576	288	≥ 1
	1.4 - 20	3	12	QPSK	1/3	256	24	1	864	432	≥ 1
	1.4 - 20	4	12	QPSK	1/3	392	24	1	1152	576	≥ 1
	1.4 - 20	5	12	QPSK	1/3	424	24	1	1440	720	≥ 1
	3-20	6	12	QPSK	1/3	600	24	1	1728	864	≥ 1
	3-20	8	12	QPSK	1/3	808	24	1	2304	1152	≥ 1
	3-20	9	12	QPSK	1/3	776	24	1	2592	1296	≥ 1
	3-20	10	12	QPSK	1/3	872	24	1	2880	1440	≥ 1
	3-20	12	12	QPSK	1/3	1224	24	1	3456	1728	≥ 1
	5-20	15	12	QPSK	1/3	1320	24	1	4320	2160	≥ 1
	5-20	16	12	QPSK	1/3	1384	24	1	4608	2304	≥ 1
	5-20	18	12	QPSK	1/3	1864	24	1	5184	2592	≥ 1
	5-20	20	12	QPSK	1/3	1736	24	1	5760	2880	≥ 1
	5-20	24	12	QPSK	1/3	2472	24	1	6912	3456	≥ 1
	10-20	25	12	QPSK	1/3	2216	24	1	7200	3600	≥ 1
	10-20	27	12	QPSK	1/3	2792	24	1	7776	3888	≥ 1
	10-20	30	12	QPSK	1/3	2664	24	1	8640	4320	≥ 1
	10-20	32	12	QPSK	1/3	2792	24	1	9216	4608	≥ 1
	10-20	36	12	QPSK	1/3	3752	24	1	10368	5184	≥ 1
	10-20	40	12	QPSK	1/3	4136	24	1	11520	5760	≥ 1
	10-20	45	12	QPSK	1/3	4008	24	1	12960	6480	≥ 1
	10-20	48	12	QPSK	1/3	4264	24	1	13824	6912	≥ 1
	15 - 20	50	12	QPSK	1/3	5160	24	1	14400	7200	≥ 1
	15 - 20	54	12	QPSK	1/3	4776	24	1	15552	7776	≥ 1
	15 - 20	60	12	QPSK	1/4	4264	24	1	17280	8640	≥ 1
	15 - 20	64	12	QPSK	1/4	4584	24	1	18432	9216	≥ 1
	15 - 20	72	12	QPSK	1/4	5160	24	1	20736	10368	≥ 1
	20	75	12	QPSK	1/5	4392	24	1	21600	10800	≥ 1
	20	80	12	QPSK	1/5	4776	24	1	23040	11520	≥ 1
	20	81	12	QPSK	1/5	4776	24	1	23328	11664	≥ 1
	20	90	12	QPSK	1/6	4008	24	1	25920	12960	≥ 1
	20	96	12	QPSK	1/6	4264	24	1	27648	13824	≥ 1

Note 1: If more than one Code Block is present, an additional CRC sequence of L = 24 Bits is attached to each Code Block (otherwise L = 0 Bit)

Table A.2.2.2.1-1a: Reference Channels for QPSK with partial RB allocation for UE UL category 0

Parameter	Ch BW	Allocated RBs	DFT-OFDM Symbols per Sub-Frame	Mod'n	Target Coding rate	Payload size	Transport block CRC	Number of code blocks per Sub-Frame (Note 1)	Total number of bits per Sub-Frame	Total symbols per Sub-Frame	UE UL Category
<b>Unit</b>	<b>MHz</b>					<b>Bits</b>	<b>Bits</b>		<b>Bits</b>		
	1.4 - 20	1	12	QPSK	1/3	72	24	1	288	144	0
	1.4 - 20	2	12	QPSK	1/3	176	24	1	576	288	0
	1.4 - 20	3	12	QPSK	1/3	256	24	1	864	432	0
	1.4 - 20	4	12	QPSK	1/3	392	24	1	1152	576	0
	1.4 - 20	5	12	QPSK	1/3	424	24	1	1440	720	0
	3-20	6	12	QPSK	1/3	600	24	1	1728	864	0
	3-20	8	12	QPSK	1/3	808	24	1	2304	1152	0
	3-20	9	12	QPSK	1/3	776	24	1	2592	1296	0
	3-20	10	12	QPSK	1/3	872	24	1	2880	1440	0
	3-20	12	12	QPSK	1/4	840	24	1	3456	1728	0
	5-20	15	12	QPSK	1/5	872	24	1	4320	2160	0
	5-20	16	12	QPSK	1/5	904	24	1	4608	2304	0
	5-20	18	12	QPSK	1/6	776	24	1	5184	2592	0
	5-20	20	12	QPSK	1/6	872	24	1	5760	2880	0
	5-20	24	12	QPSK	1/8	872	24	1	6912	3456	0
	10-20	25	12	QPSK	1/8	904	24	1	7200	3600	0
	10-20	27	12	QPSK	1/8	968	24	1	7776	3888	0
	10-20	30	12	QPSK	1/10	808	24	1	8640	4320	0

Note 1: If more than one Code Block is present, an additional CRC sequence of L = 24 Bits is attached to each Code Block (otherwise L = 0 Bit)

Note 2: For HD-FDD UE, the uplink subframes are scheduled at the 4th, 5th, 6th, 12th, 13th, 14th, 20th, 21st, 22nd, 28th, 29th, 30th, 36th, 37th, and 38th subframes every 40ms. Information bit payload is available if uplink subframe is scheduled.

Table A.2.2.2.1-1b: Reference Channels for QPSK with partial RB allocation for UE UL category M1

Parameter	Ch BW	Allocated RBs	DFT-OFDM Symbols per Sub-Frame	Mod'n	Target Coding rate	Payload size	Transport block CRC	Number of code blocks per Sub-Frame (Note 1)	Total number of bits per Sub-Frame	Total symbols per Sub-Frame	UE Category
<b>Unit</b>	<b>MHz</b>					<b>Bits</b>	<b>Bits</b>		<b>Bits</b>		
	1.4 - 20	1	12	QPSK	1/3	72	24	1	288	144	M1
	1.4 - 20	2	12	QPSK	1/3	176	24	1	576	288	M1
	1.4 - 20	3	12	QPSK	1/3	256	24	1	864	432	M1
	1.4 - 20	4	12	QPSK	1/3	392	24	1	1152	576	M1
	1.4 - 20	5	12	QPSK	1/3	424	24	1	1440	720	M1
	3-20	6	12	QPSK	1/3	600	24	1	1728	864	M1

Note 1: If more than one Code Block is present, an additional CRC sequence of L = 24 Bits is attached to each Code Block (otherwise L = 0 Bit).

Note 2: For HD-FDD UE, the uplink subframes are scheduled at the 4th, 5th and 6th subframes every 10ms for the channel bandwidth 5MHz/10MHz/15MHz/20MHz. For HD-FDD UE, the uplink subframes are scheduled at the 5th, 6th and 7th subframes every 10ms for the channel bandwidth 1.4MHz/3MHz. Information bit payload is available if uplink subframe is scheduled.

Table A.2.2.2.1-1c: Reference Channels for QPSK with partial RB allocation for UE UL category M2

Parameter	Ch BW	Allocated RBs	DFT-OFDM Symbols per Sub-Frame	Mod'n	Target Coding rate	Payload size	Transport block CRC	Number of code blocks per Sub-Frame (Note 1)	Total number of bits per Sub-Frame	Total symbols per Sub-Frame	UE Category
Unit	MHz					Bits	Bits		Bits		
	1.4 - 20	1	12	QPSK	1/3	72	24	1	288	144	M2
	1.4 - 20	2	12	QPSK	1/3	176	24	1	576	288	M2
	1.4 - 20	3	12	QPSK	1/3	256	24	1	864	432	M2
	1.4 - 20	4	12	QPSK	1/3	392	24	1	1152	576	M2
	1.4 - 20	5	12	QPSK	1/3	424	24	1	1440	720	M2
	3-20	6	12	QPSK	1/3	600	24	1	1728	864	M2
	3-20	9	12	QPSK	1/3	776	24	1	2592	1296	M2
	3-20	12	12	QPSK	1/3	1032	24	1	3456	1728	M2
	5-20	15	12	QPSK	1/3	1320	24	1	4320	2160	M2
	5-20	18	12	QPSK	1/3	1864	24	1	5184	2592	M2
	5-20	21	12	QPSK	1/3	2216	24	1	6068	3024	M2
Note 1:	If more than one Code Block is present, an additional CRC sequence of L = 24 Bits is attached to each Code Block (otherwise L = 0 Bit).										
Note 2:	For HD-FDD UE, the uplink subframes are scheduled at the 4th, 5th and 6th subframes every 10ms for the channel bandwidth 5MHz/10MHz/15MHz/20MHz. For FD-FDD UE, the uplink subframes are scheduled at the 5th, 6th and 7th subframes every 10ms for the channel bandwidth 1.4MHz/3MHz. Information bit payload is available if uplink subframe is scheduled.										

## A.2.2.2.2 16-QAM

Table A.2.2.2-1 Reference Channels for 16-QAM with partial RB allocation

Parameter	Ch BW	Allocated RBs	DFT-OFDM Symbols per Sub-Frame	Mod'n	Target Coding rate	Payload size	Transport block CRC	Number of code blocks per Sub-Frame (Note 1)	Total number of bits per Sub-Frame	Total symbols per Sub-Frame	UE Category
Unit	MHz					Bits	Bits		Bits		
	1.4 - 20	1	12	16QAM	3/4	408	24	1	576	144	≥ 1
	1.4 - 20	2	12	16QAM	3/4	840	24	1	1152	288	≥ 1
	1.4 - 20	3	12	16QAM	3/4	1288	24	1	1728	432	≥ 1
	1.4 - 20	4	12	16QAM	3/4	1736	24	1	2304	576	≥ 1
	1.4 - 20	5	12	16QAM	3/4	2152	24	1	2880	720	≥ 1
	3-20	6	12	16QAM	3/4	2600	24	1	3456	864	≥ 1
	3-20	8	12	16QAM	3/4	3496	24	1	4608	1152	≥ 1
	3-20	9	12	16QAM	3/4	3880	24	1	5184	1296	≥ 1
	3-20	10	12	16QAM	3/4	4264	24	1	5760	1440	≥ 1
	3-20	12	12	16QAM	3/4	5160	24	1	6912	1728	≥ 1
	5-20	15	12	16QAM	1/2	4264	24	1	8640	2160	≥ 1
	5-20	16	12	16QAM	1/2	4584	24	1	9216	2304	≥ 1
	5-20	18	12	16QAM	1/2	5160	24	1	10368	2592	≥ 1
	5-20	20	12	16QAM	1/3	4008	24	1	11520	2880	≥ 1
	5-20	24	12	16QAM	1/3	4776	24	1	13824	3456	≥ 1
	10-20	25	12	16QAM	1/3	4968	24	1	14400	3600	≥ 1
	10-20	27	12	16QAM	1/3	4776	24	1	15552	3888	≥ 1
	10-20	30	12	16QAM	3/4	12960	24	3	17280	4320	≥ 2
	10-20	32	12	16QAM	3/4	13536	24	3	18432	4608	≥ 2
	10-20	36	12	16QAM	3/4	15264	24	3	20736	5184	≥ 2
	10-20	40	12	16QAM	3/4	16992	24	3	23040	5760	≥ 2
	10-20	45	12	16QAM	3/4	19080	24	4	25920	6480	≥ 2
	10-20	48	12	16QAM	3/4	20616	24	4	27648	6912	≥ 2
	15 - 20	50	12	16QAM	3/4	21384	24	4	28800	7200	≥ 2
	15 - 20	54	12	16QAM	3/4	22920	24	4	31104	7776	≥ 2
	15 - 20	60	12	16QAM	2/3	23688	24	4	34560	8640	≥ 2
	15 - 20	64	12	16QAM	2/3	25456	24	4	36864	9216	≥ 2
	15 - 20	72	12	16QAM	1/2	20616	24	4	41472	10368	≥ 2
	20	75	12	16QAM	1/2	21384	24	4	43200	10800	≥ 2
	20	80	12	16QAM	1/2	22920	24	4	46080	11520	≥ 2
	20	81	12	16QAM	1/2	22920	24	4	46656	11664	≥ 2
	20	90	12	16QAM	2/5	20616	24	4	51840	12960	≥ 2
	20	96	12	16QAM	2/5	22152	24	4	55296	13824	≥ 2

Note 1: If more than one Code Block is present, an additional CRC sequence of L = 24 Bits is attached to each Code Block (otherwise L = 0 Bit)

Table A.2.2.2-1a Reference Channels for 16-QAM with partial RB allocation for UE UL category 0

Parameter	Ch BW	Allocated RBs	DFT-OFDM Symbols per Sub-Frame	Mod'n	Target Coding rate	Payload size	Transport block CRC	Number of code blocks per Sub-Frame (Note 1)	Total number of bits per Sub-Frame	Total symbols per Sub-Frame	UE UL Category
Unit	MHz					Bits	Bits		Bits		
	1.4 - 20	1	12	16QAM	3/4	408	24	1	576	144	0
	1.4 - 20	2	12	16QAM	3/4	840	24	1	1152	288	0
	1.4 - 20	4	12	16QAM	2/5	904	24	1	2304	576	0

Note 1: If more than one Code Block is present, an additional CRC sequence of L = 24 Bits is attached to each Code Block (otherwise L = 0 Bit)

Note 2: For HD-FDD UE, the uplink subframes are scheduled at the 4th, 5th, 6th, 12th, 13th, 14th, 20th, 21st, 22nd, 28th, 29th, 30th, 36th, 37th, and 38th subframes every 40ms. Information bit payload is available if uplink subframe is scheduled.

Table A.2.2.2-1b Reference Channels for 16-QAM with partial RB allocation for UE UL category M1

Parameter	Ch BW	Allocated RBs	DFT-OFDM Symbols per Sub-Frame	Mod'n	Target Coding rate	Payload size	Transport block CRC	Number of code blocks per Sub-Frame (Note 1)	Total number of bits per Sub-Frame	Total symbols per Sub-Frame	UE Category
Unit	MHz					Bits	Bits		Bits		
	1.4 - 20	1	12	16QAM	1/2	256	24	1	576	144	M1
	1.4 - 20	2	12	16QAM	1/2	552	24	1	1152	288	M1
	1.4 - 20	3	12	16QAM	1/2	840	24	1	1728	432	M1
	1.4 - 20	4	12	16QAM	2/5	904	24	1	2304	576	M1

Note 1: If more than one Code Block is present, an additional CRC sequence of L = 24 Bits is attached to each Code Block (otherwise L = 0 Bit)

Note 2: For HD-FDD UE, the uplink subframes are scheduled at the 4th, 5th, 6th, 12th, 13th, 14th, 20th, 21st, 22nd, 28th, 29th, 30th, 36th, 37th, and 38th subframes every 40ms. Information bit payload is available if uplink subframe is scheduled.

Table A.2.2.2-1c Reference Channels for 16-QAM with partial RB allocation for UE UL category M2

Parameter	Ch BW	Allocated RBs	DFT-OFDM Symbols per Sub-Frame	Mod'n	Target Coding rate	Payload size	Transport block CRC	Number of code blocks per Sub-Frame (Note 1)	Total number of bits per Sub-Frame	Total symbols per Sub-Frame	UE Category
Unit	MHz					Bits	Bits		Bits		
	1.4 - 20	1	12	16QAM	1/2	256	24	1	576	144	M2
	1.4 - 20	2	12	16QAM	1/2	552	24	1	1152	288	M2
	1.4 - 20	3	12	16QAM	1/2	840	24	1	1728	432	M2
	1.4 - 20	4	12	16QAM	1/2	1128	24	1	2304	576	M2
	1.4 - 20	5	12	16QAM	1/2	1416	24	1	2880	720	M2
	3 - 20	6	12	16QAM	1/2	1736	24	1	3456	864	M2
	3 - 20	9	12	16QAM	1/2	2600	24	1	5184	1296	M2
	3 - 20	12	12	16QAM	1/2	3496	24	1	6912	1728	M2
	5 - 20	15	12	16QAM	1/2	4264	24	1	8640	2160	M2
	5 - 20	18	12	16QAM	1/2	5160	24	1	10368	2592	M2
	5 - 20	21	12	16QAM	1/2	5992	24	1	12096	3024	M2
	5 - 20	24	12	16QAM	1/2	6968	24	2	13824	3456	M2

Note 1: If more than one Code Block is present, an additional CRC sequence of L = 24 Bits is attached to each Code Block (otherwise L = 0 Bit)

Note 2: For HD-FDD UE, the uplink subframes are scheduled at the 4th, 5th and 6th subframes every 10ms for the channel bandwidth 5MHz/10MHz/15MHz/20MHz. For HD-FDD, the uplink subframes are scheduled at the 5th, 6th, and 7th subframes every 10ms for the channel bandwidth 1.4MHz/3MHz. Information bit payload is available if uplink subframe is scheduled.



A.2.2.2.3 64-QAM

**Table A.2.2.2.3-1: Reference Channels for 64-QAM with partial RB allocation**

Parameter	Ch BW	Allocated RBs	DFT-OFDM Symbols per Sub-Frame	Mod'n	Target Coding rate	Payload size	Transport block CRC	Number of code blocks per Sub-Frame (Note 1)	Total number of bits per Sub-Frame	Total symbols per Sub-Frame	UE Category (Note 2)	UE UL Category (Note 2)
Unit	MHz					Bits	Bits		Bits			
	1.4 - 20	1	12	64QAM	3/4	616	24	1	864	144	5,8	5, 8, 13, 14
	1.4 - 20	2	12	64QAM	3/4	1256	24	1	1728	288	5,8	5, 8, 13, 14
	1.4 - 20	3	12	64QAM	3/4	1864	24	1	2592	432	5,8	5, 8, 13, 14
	1.4 - 20	4	12	64QAM	3/4	2536	24	1	3456	576	5,8	5, 8, 13, 14
	1.4 - 20	5	12	64QAM	3/4	3112	24	1	4320	720	5,8	5, 8, 13, 14
	3-20	6	12	64QAM	3/4	3752	24	1	5184	864	5,8	5, 8, 13, 14
	3-20	8	12	64QAM	3/4	5160	24	1	6912	1152	5,8	5, 8, 13, 14
	3-20	9	12	64QAM	3/4	5736	24	1	7776	1296	5,8	5, 8, 13, 14
	3-20	10	12	64QAM	3/4	6200	24	2	8640	1440	5,8	5, 8, 13, 14
	3-20	12	12	64QAM	3/4	7480	24	2	10368	1728	5,8	5, 8, 13, 14
	5-20	15	12	64QAM	3/4	9528	24	2	12960	2160	5,8	5, 8, 13, 14
	5-20	16	12	64QAM	3/4	10296	24	2	13824	2304	5,8	5, 8, 13, 14
	5-20	18	12	64QAM	3/4	11448	24	2	15552	2592	5,8	5, 8, 13, 14
	5-20	20	12	64QAM	3/4	12576	24	3	17280	2880	5,8	5, 8, 13, 14
	5-20	24	12	64QAM	3/4	15264	24	3	20736	3456	5,8	5, 8, 13, 14
	10-20	25	12	64QAM	3/4	15840	24	3	21600	3600	5,8	5, 8, 13, 14
	10-20	27	12	64QAM	3/4	16992	24	3	23328	3888	5,8	5, 8, 13, 14
	10-20	30	12	64QAM	3/4	19080	24	4	25920	4320	5,8	5, 8, 13, 14
	10-20	32	12	64QAM	3/4	20616	24	4	27648	4608	5,8	5, 8, 13, 14
	10-20	36	12	64QAM	3/4	22920	24	4	31104	5184	5,8	5, 8, 13, 14
	10-20	40	12	64QAM	3/4	25456	24	5	34560	5760	5,8	5, 8, 13, 14
	10-20	45	12	64QAM	3/4	28336	24	5	38880	6480	5,8	5, 8, 13, 14
	10-20	48	12	64QAM	3/4	30576	24	5	41472	6912	5,8	5, 8, 13, 14
	15 - 20	50	12	64QAM	3/4	31704	24	6	43200	7200	5,8	5, 8, 13, 14
	15 - 20	54	12	64QAM	3/4	34008	24	6	46656	7776	5,8	5, 8, 13, 14
	15 - 20	60	12	64QAM	3/4	37888	24	7	51840	8640	5,8	5, 8, 13, 14
	15 - 20	64	12	64QAM	3/4	40576	24	7	55296	9216	5,8	5, 8, 13, 14
	15 - 20	72	12	64QAM	3/4	45352	24	8	62208	10368	5,8	5, 8, 13, 14
	20	75	12	64QAM	3/4	46888	24	8	64800	10800	5,8	5, 8, 13, 14
	20	80	12	64QAM	3/4	51024	24	9	69120	11520	5,8	5, 8, 13, 14
	20	81	12	64QAM	3/4	51024	24	9	69984	11664	5,8	5, 8, 13, 14
	20	90	12	64QAM	2/3	51024	24	9	77760	12960	5,8	5, 8, 13, 14

	20	96	12	64QAM	3/4	61664	24	11	82944	13824	5,8	5, 8, 13, 14
Note 1:	If more than one Code Block is present, an additional CRC sequence of L = 24 Bits is attached to each Code Block (otherwise L = 0 Bit)											
Note2:	If UE does not report UE UL category, then the applicability of reference channel is determined by UE category. If UE reports UE UL category, then the applicability of reference channel is determined by UE UL category											

A.2.2.2.4 256 QAM

Table A.2.2.2.4-1: Reference Channels for 256 QAM with partial RB allocation

Parameter	Ch BW	Allocated RBs	DFT-OFDM Symbols per Sub-Frame	Mod'n	Target Coding rate	Payload size	Transport block CRC	Number of code blocks per Sub-Frame (Note 1)	Total number of bits per Sub-Frame	Total symbols per Sub-Frame	UE UL Category
Unit	MHz					Bits	Bits		Bits		
1.4 - 20	1	12	256QAM	3/4	840	24	1	1152	144	≥ 15	
1.4 - 20	2	12	256QAM	3/4	1672	24	1	2304	288	≥ 15	
1.4 - 20	3	12	256QAM	3/4	2536	24	1	3456	432	≥ 15	
1.4 - 20	4	12	256QAM	3/4	3368	24	1	4608	576	≥ 15	
1.4 - 20	5	12	256QAM	3/4	4264	24	1	5760	720	≥ 15	
3-20	6	12	256QAM	3/4	5160	24	1	6912	864	≥ 15	
3-20	8	12	256QAM	3/4	6712	24	2	9216	1152	≥ 15	
3-20	9	12	256QAM	3/4	7736	24	2	10368	1296	≥ 15	
3-20	10	12	256QAM	3/4	8504	24	2	11520	1440	≥ 15	
3-20	12	12	256QAM	3/4	10296	24	2	13824	1728	≥ 15	
5-20	15	12	256QAM	3/4	12960	24	3	17280	2160	≥ 15	
5-20	16	12	256QAM	3/4	13536	24	3	18432	2304	≥ 15	
5-20	18	12	256QAM	3/4	15264	24	3	20736	2592	≥ 15	
5-20	20	12	256QAM	3/4	16992	24	3	23040	2880	≥ 15	
5-20	24	12	256QAM	3/4	20616	24	4	27648	3456	≥ 15	
10-20	25	12	256QAM	3/4	21384	24	4	28800	3600	≥ 15	
10-20	27	12	256QAM	3/4	22920	24	4	31104	3888	≥ 15	
10-20	30	12	256QAM	3/4	25456	24	5	34560	4320	≥ 15	
10-20	32	12	256QAM	3/4	27376	24	5	36864	4608	≥ 15	
10-20	36	12	256QAM	3/4	30576	24	6	41472	5184	≥ 15	
10-20	40	12	256QAM	3/4	34008	24	6	46080	5760	≥ 15	
10-20	45	12	256QAM	3/4	37888	24	7	51840	6480	≥ 15	
10-20	48	12	256QAM	3/4	40576	24	8	55296	6912	≥ 15	
15 - 20	50	12	256QAM	3/4	42368	24	8	57600	7200	≥ 15	
15 - 20	54	12	256QAM	3/4	46888	24	8	62208	7776	≥ 15	
15 - 20	60	12	256QAM	3/4	51024	24	9	69120	8640	≥ 15	
15 - 20	64	12	256QAM	3/4	55056	24	9	73728	9216	≥ 15	
15 - 20	72	12	256QAM	3/4	61664	24	11	82944	10368	≥ 15	
20	75	12	256QAM	3/4	63776	24	11	86400	10800	≥ 15	
20	80	12	256QAM	3/4	68808	24	12	92160	11520	≥ 15	
20	81	12	256QAM	3/4	68808	24	12	93312	11664	≥ 15	
20	90	12	256QAM	3/4	76208	24	13	103680	12960	≥ 15	
20	96	12	256QAM	3/4	81176	24	14	110592	13824	≥ 15	

Note 1: If more than one Code Block is present, an additional CRC sequence of L = 24 Bits is attached to each Code Block (otherwise L = 0 Bit)

A.2.2.3 Void

Table A.2.2.3-1: Void

## A.2.3 Reference measurement channels for TDD

For TDD, the measurement channel is based on DL/UL configuration ratio of 2DL:2UL, or 1DL:4UL. 2DL:2UL is the default and used unless explicitly specified in the test case

### A.2.3.1 Full RB allocation

#### A.2.3.1.1 QPSK

**Table A.2.3.1.1-1: Reference Channels for QPSK with full RB allocation**

Parameter	Unit	Value					
		1.4	3	5	10	15	20
Channel bandwidth	MHz	1.4	3	5	10	15	20
Allocated resource blocks		6	15	25	50	75	100
Uplink-Downlink Configuration (Note 2)		1	1	1	1	1	1
DFT-OFDM Symbols per Sub-Frame		12	12	12	12	12	12
Modulation		QPSK	QPSK	QPSK	QPSK	QPSK	QPSK
Target Coding rate		1/3	1/3	1/3	1/3	1/5	1/6
Payload size							
For Sub-Frame 2,3,7,8	Bits	600	1544	2216	5160	4392	4584
Transport block CRC	Bits	24	24	24	24	24	24
Number of code blocks per Sub-Frame (Note 1)							
For Sub-Frame 2,3,7,8		1	1	1	1	1	1
Total number of bits per Sub-Frame							
For Sub-Frame 2,3,7,8	Bits	1728	4320	7200	14400	21600	28800
Total symbols per Sub-Frame							
For Sub-Frame 2,3,7,8		864	2160	3600	7200	10800	14400
UE Category		≥ 1	≥ 1	≥ 1	≥ 1	≥ 1	≥ 1
Note 1:	If more than one Code Block is present, an additional CRC sequence of L = 24 Bits is attached to each Code Block (otherwise L = 0 Bit)						
Note 2:	As per Table 4.2-2 in TS 36.211 [4]						

**Table A.2.3.1.1-1A: Reference Channels for QPSK with full RB allocation, UL-DL configuration 0**

Parameter	Unit	Value					
		1.4	3	5	10	15	20
Channel bandwidth	MHz	1.4	3	5	10	15	20
Allocated resource blocks		6	15	25	50	75	100
Uplink-Downlink Configuration (Note 2)		0	0	0	0	0	0
DFT-OFDM Symbols per Sub-Frame		12	12	12	12	12	12
Modulation		QPSK	QPSK	QPSK	QPSK	QPSK	QPSK
Target Coding rate		1/3	1/3	1/3	1/3	1/5	1/6
Payload size							
For Sub-Frame 2,3,4,7,8,9	Bits	600	1544	2216	5160	4392	4584
Transport block CRC	Bits	24	24	24	24	24	24
Number of code blocks per Sub-Frame (Note 1)		1	1	1	1	1	1
Total number of bits per Sub-Frame							
For Sub-Frame 2,3,4,7,8,9	Bits	1728	4320	7200	14400	21600	28800
Total symbols per Sub-Frame							
For Sub-Frame 2,3,4,7,8,9		864	2160	3600	7200	10800	14400
UE Category		≥ 1	≥ 1	≥ 1	≥ 1	≥ 1	≥ 1
Note 1:	If more than one Code Block is present, an additional CRC sequence of L = 24 Bits is attached to each Code Block (otherwise L = 0 Bit)						
Note 2:	As per Table 4.2-2 in TS 36.211 [4]						

**Table A.2.3.1.1-1a: Reference Channels for QPSK with full/maximum RB allocation for UE UL category 0**

Parameter	Unit	Value					
		1.4	3	5	10	15	20
Channel bandwidth	MHz	1.4	3	5	10	15	20
Allocated resource blocks		6	15	25	36	36	36
Uplink-Downlink Configuration (Note 2)		1	1	1	1	1	1
DFT-OFDM Symbols per Sub-Frame		12	12	12	12	12	12
Modulation		QPSK	QPSK	QPSK	QPSK	QPSK	QPSK
Target Coding rate		1/3	1/5	1/8	1/10	1/10	1/10
Payload size							
For Sub-Frame 2,3,7,8	Bits	600	872	904	1000	1000	1000
Transport block CRC	Bits	24	24	24	24	24	24
Number of code blocks per Sub-Frame (Note 1)							
For Sub-Frame 2,3,7,8		1	1	1	1	1	1
Total number of bits per Sub-Frame							
For Sub-Frame 2,3,7,8	Bits	1728	4320	7200	10368	10368	10368
Total symbols per Sub-Frame							
For Sub-Frame 2,3,7,8		864	2160	3600	5184	5184	5184
UE UL Category		0	0	0	0	0	0

NOTE 1: If more than one Code Block is present, an additional CRC sequence of L = 24 Bits is attached to each Code Block (otherwise L = 0 Bit)

NOTE 2: As per Table 4.2-2 in TS 36.211

**Table A.2.3.1.1-1b: Reference Channels for QPSK with full/maximum RB allocation for UE UL category M1**

Parameter	Unit	Value					
		1.4	3	5	10	15	20
Channel bandwidth	MHz	1.4	3	5	10	15	20
Allocated resource blocks		6	6	6	6	6	6
Uplink-Downlink Configuration (Note 2)		1	1	1	1	1	1
DFT-OFDM Symbols per Sub-Frame		12	12	12	12	12	12
Modulation		QPSK	QPSK	QPSK	QPSK	QPSK	QPSK
Target Coding rate		1/3	1/3	1/3	1/3	1/3	1/3
Payload size							
For Sub-Frame 2,3,7,8	Bits	600	600	600	600	600	600
Transport block CRC	Bits	24	24	24	24	24	24
Number of code blocks per Sub-Frame (Note 1)							
For Sub-Frame 2,3,7,8		1	1	1	1	1	1
Total number of bits per Sub-Frame							
For Sub-Frame 2,3,7,8	Bits	1728	1728	1728	1728	1728	1728
Total symbols per Sub-Frame							
For Sub-Frame 2,3,7,8		864	864	864	864	864	864
UE UL Category		M1	M1	M1	M1	M1	M1

NOTE 1: If more than one Code Block is present, an additional CRC sequence of L = 24 Bits is attached to each Code Block (otherwise L = 0 Bit)

NOTE 2: As per Table 4.2-2 in TS 36.211

**Table A.2.3.1.1-1c: Reference Channels for QPSK with full/maximum RB allocation for UE UL category M2**

Parameter	Unit	Value					
Channel bandwidth	MHz	1.4	3	5	10	15	20
Allocated resource blocks		6	12	24	24	24	24
Uplink-Downlink Configuration (Note 2)		1	1	1	1	1	1
DFT-OFDM Symbols per Sub-Frame		12	12	12	12	12	12
Modulation		QPSK	QPSK	QPSK	QPSK	QPSK	QPSK
Target Coding rate		1/3	1/3	1/3	1/3	1/3	1/3
Payload size							
For Sub-Frame 2,3,7,8	Bits	600	1224	2472	2472	2472	2472
Transport block CRC	Bits	24	24	24	24	24	24
Number of code blocks per Sub-Frame (Note 1)							
For Sub-Frame 2,3,7,8		1	1	1	1	1	1
Total number of bits per Sub-Frame							
For Sub-Frame 2,3,7,8	Bits	1728	3456	6912	6912	6912	6912
Total symbols per Sub-Frame							
For Sub-Frame 2,3,7,8		864	1728	3456	3456	3456	3456
UE UL Category		M2	M2	M2	M2	M2	M2

NOTE 1: If more than one Code Block is present, an additional CRC sequence of L = 24 Bits is attached to each Code Block (otherwise L = 0 Bit)

NOTE 2: As per Table 4.2-2 in TS 36.211

**A.2.3.1.2 16-QAM****Table A.2.3.1.2-1: Reference Channels for 16-QAM with full RB allocation**

Parameter	Unit	Value					
Channel bandwidth	MHz	1.4	3	5	10	15	20
Allocated resource blocks		6	15	25	50	75	100
Uplink-Downlink Configuration (Note 2)		1	1	1	1	1	1
DFT-OFDM Symbols per Sub-Frame		12	12	12	12	12	12
Modulation		16QAM	16QAM	16QAM	16QAM	16QAM	16QAM
Target Coding rate		3/4	1/2	1/3	3/4	1/2	1/3
Payload size							
For Sub-Frame 2,3,7,8	Bits	2600	4264	4968	21384	21384	19848
Transport block CRC	Bits	24	24	24	24	24	24
Number of code blocks per Sub-Frame (Note 1)							
For Sub-Frame 2,3,7,8		1	1	1	4	4	4
Total number of bits per Sub-Frame							
For Sub-Frame 2,3,7,8	Bits	3456	8640	14400	28800	43200	57600
Total symbols per Sub-Frame							
For Sub-Frame 2,3,7,8		864	2160	3600	7200	10800	14400
UE Category		≥ 1	≥ 1	≥ 1	≥ 2	≥ 2	≥ 2

Note 1: If more than one Code Block is present, an additional CRC sequence of L = 24 Bits is attached to each Code Block (otherwise L = 0 Bit)

Note 2: As per Table 4.2-2 in TS 36.211 [4]

**Table A.2.3.1.2-1A: Reference Channels for 16-QAM with full RB allocation, UL-DL configuration 0**

Parameter	Unit	Value					
Channel bandwidth	MHz	1.4	3	5	10	15	20
Allocated resource blocks		6	15	25	50	75	100
Uplink-Downlink Configuration (Note 2)		0	0	0	0	0	0
DFT-OFDM Symbols per Sub-Frame		12	12	12	12	12	12
Modulation		16QAM	16QAM	16QAM	16QAM	16QAM	16QAM
Target Coding rate		3/4	1/2	1/3	3/4	1/2	1/3
Payload size							
For Sub-Frame 2,3,4,7,8,9	Bits	2600	4264	4968	21384	21384	19848
Transport block CRC	Bits	24	24	24	24	24	24
Number of code blocks - C		1	1	1	4	4	4
Total number of bits per Sub-Frame							
For Sub-Frame 2,3,4,7,8,9	Bits	3456	8640	14400	28800	43200	57600
Total symbols per Sub-Frame							
For Sub-Frame 2,3,4,7,8,9		864	2160	3600	7200	10800	14400
UE Category		≥ 1	≥ 1	≥ 1	≥ 2	≥ 2	≥ 2
Note 1: If more than one Code Block is present, an additional CRC sequence of L = 24 Bits is attached to each Code Block (otherwise L = 0 Bit)							
Note 2: As per Table 4.2-2 in TS 36.211 [4]							

**Table A.2.3.1.2-1a: Reference Channels for 16-QAM with maximum RB allocation for UE UL category 0**

Parameter	Unit	Value					
Channel bandwidth	MHz	1.4	3	5	10	15	20
Allocated resource blocks		5	5	5	5	5	5
Uplink-Downlink Configuration (Note 2)		1	1	1	1	1	1
DFT-OFDM Symbols per Sub-Frame		12	12	12	12	12	12
Modulation		16QAM	16QAM	16QAM	16QAM	16QAM	16QAM
Target Coding rate		1/3	1/3	1/3	1/3	1/3	1/3
Payload size							
For Sub-Frame 2,3,7,8	Bits	872	872	872	872	872	872
Transport block CRC	Bits	24	24	24	24	24	24
Number of code blocks per Sub-Frame (Note 1)							
For Sub-Frame 2,3,7,8		1	1	1	1	1	1
Total number of bits per Sub-Frame							
For Sub-Frame 2,3,7,8	Bits	2880	2880	2880	2880	2880	2880
Total symbols per Sub-Frame							
For Sub-Frame 2,3,7,8		720	720	720	720	720	720
UE UL Category		0	0	0	0	0	0
NOTE 1: If more than one Code Block is present, an additional CRC sequence of L = 24 Bits is attached to each Code Block (otherwise L = 0 Bit)							
NOTE 2: As per Table 4.2-2 in TS 36.211[4]							

**Table A.2.3.1.2-1b: Reference Channels for 16-QAM with maximum RB allocation for UE UL category M1**

Parameter	Unit	Value					
		1.4	3	5	10	15	20
Channel bandwidth	MHz	1.4	3	5	10	15	20
Allocated resource blocks		5	5	5	5	5	5
Uplink-Downlink Configuration (Note 2)		1	1	1	1	1	1
DFT-OFDM Symbols per Sub-Frame		12	12	12	12	12	12
Modulation		16QAM	16QAM	16QAM	16QAM	16QAM	16QAM
Target Coding rate		1/3	1/3	1/3	1/3	1/3	1/3
Payload size							
For Sub-Frame 2,3,7,8	Bits	872	872	872	872	872	872
Transport block CRC	Bits	24	24	24	24	24	24
Number of code blocks per Sub-Frame (Note 1)							
For Sub-Frame 2,3,7,8		1	1	1	1	1	1
Total number of bits per Sub-Frame							
For Sub-Frame 2,3,7,8	Bits	2880	2880	2880	2880	2880	2880
Total symbols per Sub-Frame							
For Sub-Frame 2,3,7,8		720	720	720	720	720	720
UE Category		M1	M1	M1	M1	M1	M1
NOTE 1: If more than one Code Block is present, an additional CRC sequence of L = 24 Bits is attached to each Code Block (otherwise L = 0 Bit)							
NOTE 2: As per Table 4.2-2 in TS 36.211[4]							

**Table A.2.3.1.2-1c: Reference Channels for 16-QAM with maximum RB allocation for UE UL category M2**

Parameter	Unit	Value					
		1.4	3	5	10	15	20
Channel bandwidth	MHz	1.4	3	5	10	15	20
Allocated resource blocks		6	12	24	24	24	24
Uplink-Downlink Configuration (Note 2)		1	1	1	1	1	1
DFT-OFDM Symbols per Sub-Frame		12	12	12	12	12	12
Modulation		16QAM	16QAM	16QAM	16QAM	16QAM	16QAM
Target Coding rate		1/3	1/3	1/3	1/3	1/3	1/3
Payload size							
For Sub-Frame 2,3,7,8	Bits	1032	2088	4264	4264	4264	4264
Transport block CRC	Bits	24	24	24	24	24	24
Number of code blocks per Sub-Frame (Note 1)							
For Sub-Frame 2,3,7,8		1	1	1	1	1	1
Total number of bits per Sub-Frame							
For Sub-Frame 2,3,7,8	Bits	3456	6912	13824	13824	13824	13824
Total symbols per Sub-Frame							
For Sub-Frame 2,3,7,8		864	1728	3456	3456	3456	3456
UE Category		M2	M2	M2	M2	M2	M2
NOTE 1: If more than one Code Block is present, an additional CRC sequence of L = 24 Bits is attached to each Code Block (otherwise L = 0 Bit)							
NOTE 2: As per Table 4.2-2 in TS 36.211[4]							



## A.2.3.1.3 64-QAM

Table A.2.3.1.3-1: Reference Channels for 64-QAM with full RB allocation

Parameter	Unit	Value					
		1.4	3	5	10	15	20
Channel bandwidth	MHz	1.4	3	5	10	15	20
Allocated resource blocks		6	15	25	50	75	100
Uplink-Downlink Configuration (Note 2)		1	1	1	1	1	1
DFT-OFDM Symbols per Sub-Frame		12	12	12	12	12	12
Modulation		64QAM	64QAM	64QAM	64QAM	64QAM	64QAM
Target Coding rate		3/4	3/4	3/4	3/4	3/4	3/4
Payload size							
For Sub-Frame 2,3,7,8	Bits	3752	9528	15840	31704	46888	63776
Transport block CRC	Bits	24	24	24	24	24	24
Number of code blocks per Sub-Frame (Note 1)							
For Sub-Frame 2,3,7,8		1	2	3	6	8	11
Total number of bits per Sub-Frame							
For Sub-Frame 2,3,7,8	Bits	5184	12960	21600	43200	64800	86400
Total symbols per Sub-Frame							
For Sub-Frame 2,3,7,8		864	2160	3600	7200	10800	14400
UE Category (Note 3)		5, 8	5, 8	5, 8	5, 8	5, 8	5, 8
UE UL Category (Note 3)		5, 8, 13, 14	5, 8, 13, 14	5, 8, 13, 14	5, 8, 13, 14	5, 8, 13, 14	5, 8, 13, 14
Note 1: If more than one Code Block is present, an additional CRC sequence of L = 24 Bits is attached to each Code Block (otherwise L = 0 Bit) Note 2: As per Table 4.2-2 in TS 36.211 [4] Note 3: If UE does not report UE UL category, then the applicability of reference channel is determined by UE category. If UE reports UE UL category, then the applicability of reference channel is determined by UE UL category.							

## A.2.3.1.4 256 QAM

Table A.2.3.1.4-1: Reference Channels for 256 QAM with full RB allocation

Parameter	Unit	Value					
		1.4	3	5	10	15	20
Channel bandwidth	MHz	1.4	3	5	10	15	20
Allocated resource blocks		6	15	25	50	75	100
Uplink-Downlink Configuration (Note 2)		1	1	1	1	1	1
DFT-OFDM Symbols per Sub-Frame		12	12	12	12	12	12
Modulation		256QAM	256QAM	256QAM	256QAM	256QAM	256QAM
Target Coding rate		3/4	3/4	3/4	3/4	3/4	3/4
Payload size							
For Sub-Frame 2,3,7,8	Bits	5160	12960	21384	42368	63776	84760
Transport block CRC	Bits	24	24	24	24	24	24
Number of code blocks per Sub-Frame (Note 1)							
For Sub-Frame 2,3,7,8		1	3	4	8	11	15
Total number of bits per Sub-Frame							
For Sub-Frame 2,3,7,8	Bits	6912	17280	28800	57600	86400	115200
Total symbols per Sub-Frame							
For Sub-Frame 2,3,7,8		864	2160	3600	7200	10800	14400
UE UL Category		≥ 15	≥ 15	≥ 15	≥ 15	≥ 15	≥ 15
Note 1: If more than one Code Block is present, an additional CRC sequence of L = 24 Bits is attached to each Code Block (otherwise L = 0 Bit) Note 2: As per Table 4.2-2 in TS 36.211 [4]							

## A.2.3.2 Partial RB allocation

For each channel bandwidth, various partial RB allocations are specified. The number of allocated RBs is chosen according to values specified in the Tx and Rx requirements. The single allocated RB case is included.

The allocated RBs are contiguous and start from one end of the channel bandwidth. A single allocated RB is at one end of the channel bandwidth.

### A.2.3.2.1 QPSK

**Table A.2.3.2.1-1: Reference Channels for QPSK with partial RB allocation**

Parameter	Ch BW	Allocated RBs	UDL Configuration (Note 2)	DFT-OFDM Symbols per Sub-Frame	Mod'n	Target Coding rate	Payload size for Sub-Frame 2, 3, 7, 8	Transport block CRC	Number of code blocks per Sub-Frame (Note 1)	Total number of bits per Sub-Frame for Sub-Frame 2, 3, 7, 8	Total symbols per Sub-Frame for Sub-Frame 2, 3, 7, 8	UE Category
Unit	MHz						Bits	Bits		Bits		
	1.4 - 20	1	1	12	QPSK	1/3	72	24	1	288	144	≥ 1
	1.4 - 20	2	1	12	QPSK	1/3	176	24	1	576	288	≥ 1
	1.4 - 20	3	1	12	QPSK	1/3	256	24	1	864	432	≥ 1
	1.4 - 20	4	1	12	QPSK	1/3	392	24	1	1152	576	≥ 1
	1.4 - 20	5	1	12	QPSK	1/3	424	24	1	1440	720	≥ 1
	3-20	6	1	12	QPSK	1/3	600	24	1	1728	864	≥ 1
	3-20	8	1	12	QPSK	1/3	808	24	1	2304	1152	≥ 1
	3-20	9	1	12	QPSK	1/3	776	24	1	2592	1296	≥ 1
	3-20	10	1	12	QPSK	1/3	872	24	1	2880	1440	≥ 1
	3-20	12	1	12	QPSK	1/3	1224	24	1	3456	1728	≥ 1
	5-20	15	1	12	QPSK	1/3	1320	24	1	4320	2160	≥ 1
	5-20	16	1	12	QPSK	1/3	1384	24	1	4608	2304	≥ 1
	5-20	18	1	12	QPSK	1/3	1864	24	1	5184	2592	≥ 1
	5-20	20	1	12	QPSK	1/3	1736	24	1	5760	2880	≥ 1
	5-20	24	1	12	QPSK	1/3	2472	24	1	6912	3456	≥ 1
	10-20	25	1	12	QPSK	1/3	2216	24	1	7200	3600	≥ 1
	10-20	27	1	12	QPSK	1/3	2792	24	1	7776	3888	≥ 1
	10-20	30	1	12	QPSK	1/3	2664	24	1	8640	4320	≥ 1
	10-20	32	1	12	QPSK	1/3	2792	24	1	9216	4608	≥ 1
	10-20	36	1	12	QPSK	1/3	3752	24	1	10368	5184	≥ 1
	10-20	40	1	12	QPSK	1/3	4136	24	1	11520	5760	≥ 1
	10-20	45	1	12	QPSK	1/3	4008	24	1	12960	6480	≥ 1
	10-20	48	1	12	QPSK	1/3	4264	24	1	13824	6912	≥ 1
	15 - 20	50	1	12	QPSK	1/3	5160	24	1	14400	7200	≥ 1
	15 - 20	54	1	12	QPSK	1/3	4776	24	1	15552	7776	≥ 1
	15 - 20	60	1	12	QPSK	1/4	4264	24	1	17280	8640	≥ 1
	15 - 20	64	1	12	QPSK	1/4	4584	24	1	18432	9216	≥ 1
	15 - 20	72	1	12	QPSK	1/4	5160	24	1	20736	10368	≥ 1
	20	75	1	12	QPSK	1/5	4392	24	1	21600	10800	≥ 1
	20	80	1	12	QPSK	1/5	4776	24	1	23040	11520	≥ 1
	20	81	1	12	QPSK	1/5	4776	24	1	23328	11664	≥ 1
	20	90	1	12	QPSK	1/6	4008	24	1	25920	12960	≥ 1
	20	96	1	12	QPSK	1/6	4264	24	1	27648	13824	≥ 1

Note 1: If more than one Code Block is present, an additional CRC sequence of L = 24 Bits is attached to each Code Block (otherwise L = 0 Bit)

Note 2: As per Table 4.2-2 in TS 36.211 [4]

Table A.2.3.2.1-1A: Reference Channels for QPSK with partial RB allocation, UL-DL configuration 0

Parameter	Ch BW	Allocated RBs	UDL Configuration (Note 2)	DFT-OFDM Symbols per Sub-Frame	Mod'n	Target Coding rate	Payload size for Sub-Frame 2, 3, 4, 7, 8, 9	Transport block CRC	Number of code blocks per Sub-Frame (Note 1)	Total number of bits per Sub-Frame for Sub-Frame 2, 3, 4, 7, 8, 9	Total symbols per Sub-Frame for Sub-Frame 2, 3, 4, 7, 8, 9	UE Category
Unit	MHz						Bits	Bits		Bits		
	1.4-20	1	0	12	QPSK	1/3	72	24	1	288	144	≥ 1
	1.4-20	2	0	12	QPSK	1/3	176	24	1	576	288	≥ 1
	1.4-20	3	0	12	QPSK	1/3	256	24	1	864	432	≥ 1
	1.4-20	4	0	12	QPSK	1/3	392	24	1	1152	576	≥ 1
	1.4-20	5	0	12	QPSK	1/3	424	24	1	1440	720	≥ 1
	3-20	6	0	12	QPSK	1/3	600	24	1	1728	864	≥ 1
	3-20	8	0	12	QPSK	1/3	808	24	1	2304	1152	≥ 1
	3-20	9	0	12	QPSK	1/3	776	24	1	2592	1296	≥ 1
	3-20	10	0	12	QPSK	1/3	872	24	1	2880	1440	≥ 1
	3-20	12	0	12	QPSK	1/3	1224	24	1	3456	1728	≥ 1
	5-20	15	0	12	QPSK	1/3	1320	24	1	4320	2160	≥ 1
	5-20	16	0	12	QPSK	1/3	1384	24	1	4608	2304	≥ 1
	5-20	18	0	12	QPSK	1/3	1864	24	1	5184	2592	≥ 1
	5-20	20	0	12	QPSK	1/3	1736	24	1	5760	2880	≥ 1
	5-20	24	0	12	QPSK	1/3	2472	24	1	6912	3456	≥ 1
	10-20	25	0	12	QPSK	1/3	2216	24	1	7200	3600	≥ 1
	10-20	27	0	12	QPSK	1/3	2792	24	1	7776	3888	≥ 1
	10-20	30	0	12	QPSK	1/3	2664	24	1	8640	4320	≥ 1
	10-20	32	0	12	QPSK	1/3	2792	24	1	9216	4608	≥ 1
	10-20	36	0	12	QPSK	1/3	3752	24	1	10368	5184	≥ 1
	10-20	40	0	12	QPSK	1/3	4136	24	1	11520	5760	≥ 1
	10-20	45	0	12	QPSK	1/3	4008	24	1	12960	6480	≥ 1
	10-20	48	0	12	QPSK	1/3	4264	24	1	13824	6912	≥ 1
	15-20	50	0	12	QPSK	1/3	5160	24	1	14400	7200	≥ 1
	15-20	54	0	12	QPSK	1/3	4776	24	1	15552	7776	≥ 1
	15-20	60	0	12	QPSK	1/4	4264	24	1	17280	8640	≥ 1
	15-20	64	0	12	QPSK	1/4	4584	24	1	18432	9216	≥ 1
	15-20	72	0	12	QPSK	1/4	5160	24	1	20736	10368	≥ 1
	20	75	0	12	QPSK	1/5	4392	24	1	21600	10800	≥ 1
	20	80	0	12	QPSK	1/5	4776	24	1	23040	11520	≥ 1
	20	81	0	12	QPSK	1/5	4776	24	1	23328	11664	≥ 1
	20	90	0	12	QPSK	1/6	4008	24	1	25920	12960	≥ 1
	20	96	0	12	QPSK	1/6	4264	24	1	27648	13824	≥ 1

Note 1: If more than one Code Block is present, an additional CRC sequence of L = 24 Bits is attached to each Code Block (otherwise L = 0 Bit)

Note 2: As per Table 4.2-2 in TS 36.211 [4]

Table A.2.3.2.1-1a: Reference Channels for QPSK with partial RB allocation for UE UL category 0

Parameter	Ch BW	Allocated RBs	UDL Configuration (Note 2)	DFT-OFDM Symbols per Sub-Frame	Mod'n	Target Coding rate	Payload size for Sub-Frame 2, 3, 7, 8	Transport block CRC	Number of code blocks per Sub-Frame (Note 1)	Total number of bits per Sub-Frame for Sub-Frame 2, 3, 7, 8	Total symbols per Sub-Frame for Sub-Frame 2, 3, 7, 8	UE UL Category
Unit	MHz						Bits	Bits		Bits		
	1.4 - 20	1	1	12	QPSK	1/3	72	24	1	288	144	0
	1.4 - 20	2	1	12	QPSK	1/3	176	24	1	576	288	0
	1.4 - 20	3	1	12	QPSK	1/3	256	24	1	864	432	0
	1.4 - 20	4	1	12	QPSK	1/3	392	24	1	1152	576	0
	1.4 - 20	5	1	12	QPSK	1/3	424	24	1	1440	720	0
	3-20	6	1	12	QPSK	1/3	600	24	1	1728	864	0
	3-20	8	1	12	QPSK	1/3	808	24	1	2304	1152	0
	3-20	9	1	12	QPSK	1/3	776	24	1	2592	1296	0
	3-20	10	1	12	QPSK	1/3	872	24	1	2880	1440	0
	3-20	12	1	12	QPSK	1/4	840	24	1	3456	1728	0
	5-20	15	1	12	QPSK	1/5	872	24	1	4320	2160	0
	5-20	16	1	12	QPSK	1/5	904	24	1	4608	2304	0
	5-20	18	1	12	QPSK	1/6	776	24	1	5184	2592	0
	5-20	20	1	12	QPSK	1/6	872	24	1	5760	2880	0
	5-20	24	1	12	QPSK	1/8	872	24	1	6912	3456	0
	10-20	25	1	12	QPSK	1/8	904	24	1	7200	3600	0
	10-20	27	1	12	QPSK	1/8	968	24	1	7776	3888	0
	10-20	30	1	12	QPSK	1/10	808	24	1	8640	4320	0
Note 1:	If more than one Code Block is present, an additional CRC sequence of L = 24 Bits is attached to each Code Block (otherwise L = 0 Bit)											
Note 2:	As per Table 4.2-2 in TS 36.211 [4]											

Table A.2.3.2.1-1b: Reference Channels for QPSK with partial RB allocation for UE UL category M1

Parameter	Ch BW	Allocated RBs	UDL Configuration (Note 2)	DFT-OFDM Symbols per Sub-Frame	Mod'n	Target Coding rate	Payload size for Sub-Frame 2, 3, 7, 8	Transport block CRC	Number of code blocks per Sub-Frame (Note 1)	Total number of bits per Sub-Frame for Sub-Frame 2, 3, 7, 8	Total symbols per Sub-Frame for Sub-Frame 2, 3, 7, 8	UE Category
Unit	MHz						Bits	Bits		Bits		
	1.4 - 20	1	1	12	QPSK	1/3	72	24	1	288	144	M1
	1.4 - 20	2	1	12	QPSK	1/3	176	24	1	576	288	M1
	1.4 - 20	3	1	12	QPSK	1/3	256	24	1	864	432	M1
	1.4 - 20	4	1	12	QPSK	1/3	392	24	1	1152	576	M1
	1.4 - 20	5	1	12	QPSK	1/3	424	24	1	1440	720	M1
	3-20	6	1	12	QPSK	1/3	600	24	1	1728	864	M1
Note 1:	If more than one Code Block is present, an additional CRC sequence of L = 24 Bits is attached to each Code Block (otherwise L = 0 Bit)											
Note 2:	As per Table 4.2-2 in TS 36.211 [4]											

Table A.2.3.2.1-1c: Reference Channels for QPSK with partial RB allocation for UE UL category M2

Parameter	Ch BW	Allocated RBs	UDL Configuration (Note 2)	DFT-OFDM Symbols per Sub-Frame	Mod'n	Target Coding rate	Payload size for Sub-Frame 2, 3, 7, 8	Transport block CRC	Number of code blocks per Sub-Frame (Note 1)	Total number of bits per Sub-Frame for Sub-Frame 2, 3, 7, 8	Total symbols per Sub-Frame for Sub-Frame 2, 3, 7, 8	UE Category
Unit	MHz						Bits	Bits		Bits		
	1.4 - 20	1	1	12	QPSK	1/3	72	24	1	288	144	M2
	1.4 - 20	2	1	12	QPSK	1/3	176	24	1	576	288	M2
	1.4 - 20	3	1	12	QPSK	1/3	256	24	1	864	432	M2
	1.4 - 20	4	1	12	QPSK	1/3	392	24	1	1152	576	M2
	1.4 - 20	5	1	12	QPSK	1/3	424	24	1	1440	720	M2
	3-20	6	1	12	QPSK	1/3	600	24	1	1728	864	M2
	3-20	9	1	12	QPSK	1/3	776	24	1	2592	1296	M2
	3-20	12	1	12	QPSK	1/3	1032	24	1	3456	1728	M2
	5-20	15	1	12	QPSK	1/3	1320	24	1	4320	2160	M2
	5-20	18	1	12	QPSK	1/3	1864	24	1	5184	2592	M2
	5-20	21	1	12	QPSK	1/3	2216	24	1	6068	3024	M2
Note 1:	If more than one Code Block is present, an additional CRC sequence of L = 24 Bits is attached to each Code Block (otherwise L = 0 Bit).											
Note 2:	As per Table 4.2-2 in TS 36.211 [4].											

A.2.3.2.2 16-QAM

Table A.2.3.2.2-1: Reference Channels for 16QAM with partial RB allocation

Parameter	Ch BW	Allocated RBs	UDL Configuration (Note 2)	DFT-OFDM Symbols per Sub-Frame	Mod'n	Target Coding rate	Payload size for Sub-Frame 2, 3, 7, 8	Transport block CRC	Number of code blocks per Sub-Frame (Note 1)	Total number of bits per Sub-Frame for Sub-Frame 2, 3, 7, 8	Total symbols per Sub-Frame for Sub-Frame 2, 3, 7, 8	UE Category
Unit	MHz						Bits	Bits		Bits		
	1.4 - 20	1	1	12	16QAM	3/4	408	24	1	576	144	≥ 1
	1.4 - 20	2	1	12	16QAM	3/4	840	24	1	1152	288	≥ 1
	1.4 - 20	3	1	12	16QAM	3/4	1288	24	1	1728	432	≥ 1
	1.4 - 20	4	1	12	16QAM	3/4	1736	24	1	2304	576	≥ 1
	1.4 - 20	5	1	12	16QAM	3/4	2152	24	1	2880	720	≥ 1
	3-20	6	1	12	16QAM	3/4	2600	24	1	3456	864	≥ 1
	3-20	8	1	12	16QAM	3/4	3496	24	1	4608	1152	≥ 1
	3-20	9	1	12	16QAM	3/4	3880	24	1	5184	1296	≥ 1
	3-20	10	1	12	16QAM	3/4	4264	24	1	5760	1440	≥ 1
	3-20	12	1	12	16QAM	3/4	5160	24	1	6912	1728	≥ 1
	5-20	15	1	12	16QAM	1/2	4264	24	1	8640	2160	≥ 1
	5-20	16	1	12	16QAM	1/2	4584	24	1	9216	2304	≥ 1
	5-20	18	1	12	16QAM	1/2	5160	24	1	10368	2592	≥ 1
	5-20	20	1	12	16QAM	1/3	4008	24	1	11520	2880	≥ 1
	5-20	24	1	12	16QAM	1/3	4776	24	1	13824	3456	≥ 1
	10-20	25	1	12	16QAM	1/3	4968	24	1	14400	3600	≥ 1
	10-20	27	1	12	16QAM	1/3	4776	24	1	15552	3888	≥ 1
	10-20	30	1	12	16QAM	3/4	12960	24	3	17280	4320	≥ 2
	10-20	32	1	12	16QAM	3/4	13536	24	3	18432	4608	≥ 2
	10-20	36	1	12	16QAM	3/4	15264	24	3	20736	5184	≥ 2
	10-20	40	1	12	16QAM	3/4	16992	24	3	23040	5760	≥ 2
	10-20	45	1	12	16QAM	3/4	19080	24	4	25920	6480	≥ 2
	10-20	48	1	12	16QAM	3/4	20616	24	4	27648	6912	≥ 2
	15 - 20	50	1	12	16QAM	3/4	21384	24	4	28800	7200	≥ 2
	15 - 20	54	1	12	16QAM	3/4	22920	24	4	31104	7776	≥ 2
	15 - 20	60	1	12	16QAM	2/3	23688	24	4	34560	8640	≥ 2
	15 - 20	64	1	12	16QAM	2/3	25456	24	4	36864	9216	≥ 2
	15 - 20	72	1	12	16QAM	1/2	20616	24	4	41472	10368	≥ 2
	20	75	1	12	16QAM	1/2	21384	24	4	43200	10800	≥ 2
	20	80	1	12	16QAM	1/2	22920	24	4	46080	11520	≥ 2
	20	81	1	12	16QAM	1/2	22920	24	4	46656	11664	≥ 2
	20	90	1	12	16QAM	2/5	20616	24	4	51840	12960	≥ 2
	20	96	1	12	16QAM	2/5	22152	24	4	55296	13824	≥ 2

Note 1: If more than one Code Block is present, an additional CRC sequence of L = 24 Bits is attached to each Code Block (otherwise L = 0 Bit)  
 Note 2: As per Table 4.2-2 in TS 36.211 [4]

**Table A.2.3.2.2-1A: Reference Channels for 16-QAM with partial RB allocation, UL-DL configuration 0**

Parameter	Ch BW	Allocated RBs	UDL Configuration (Note 2)	DFT-OFDM Symbols per Sub-Frame	Mod'n	Target Coding rate	Payload size for Sub-Frame 2, 3, 4, 7, 8, 9	Transport block CRC	Number of code blocks per Sub-Frame (Note 1)	Total number of bits per Sub-Frame for Sub-Frame 2, 3, 4, 7, 8, 9	Total symbols per Sub-Frame for Sub-Frame 2, 3, 4, 7, 8, 9	UE Category
Unit	MHz					Bits	Bits			Bits		
	1.4-20	1	0	12	16QAM	3/4	408	24	1	576	144	≥ 1
	1.4-20	2	0	12	16QAM	3/4	840	24	1	1152	288	≥ 1
	1.4-20	3	0	12	16QAM	3/4	1288	24	1	1728	432	≥ 1
	1.4-20	4	0	12	16QAM	3/4	1736	24	1	2304	576	≥ 1
	1.4-20	5	0	12	16QAM	3/4	2152	24	1	2880	720	≥ 1
	3-20	6	0	12	16QAM	3/4	2600	24	1	3456	864	≥ 1
	3-20	8	0	12	16QAM	3/4	3496	24	1	4608	1152	≥ 1
	3-20	9	0	12	16QAM	3/4	3880	24	1	5184	1296	≥ 1
	3-20	10	0	12	16QAM	3/4	4264	24	1	5760	1440	≥ 1
	3-20	12	0	12	16QAM	3/4	5160	24	1	6912	1728	≥ 1
	5-20	15	0	12	16QAM	1/2	4264	24	1	8640	2160	≥ 1
	5-20	16	0	12	16QAM	1/2	4584	24	1	9216	2304	≥ 1
	5-20	18	0	12	16QAM	1/2	5160	24	1	10368	2592	≥ 1
	5-20	20	0	12	16QAM	1/3	4008	24	1	11520	2880	≥ 1
	5-20	24	0	12	16QAM	1/3	4776	24	1	13824	3456	≥ 1
	10-20	25	0	12	16QAM	1/3	4968	24	1	14400	3600	≥ 1
	10-20	27	0	12	16QAM	1/3	4776	24	1	15552	3888	≥ 1
	10-20	30	0	12	16QAM	3/4	12960	24	3	17280	4320	≥ 2
	10-20	32	0	12	16QAM	3/4	13536	24	3	18432	4608	≥ 2
	10-20	36	0	12	16QAM	3/4	15264	24	3	20736	5184	≥ 2
	10-20	40	0	12	16QAM	3/4	16992	24	3	23040	5760	≥ 2
	10-20	45	0	12	16QAM	3/4	19080	24	4	25920	6480	≥ 2
	10-20	48	0	12	16QAM	3/4	20616	24	4	27648	6912	≥ 2
	15-20	50	0	12	16QAM	3/4	21384	24	4	28800	7200	≥ 2
	15-20	54	0	12	16QAM	3/4	22920	24	4	31104	7776	≥ 2
	15-20	60	0	12	16QAM	2/3	23688	24	4	34560	8640	≥ 2



	15-20	64	0	12	16QAM	2/3	25456	24	4	36864	9216	≥ 2
	15-20	72	0	12	16QAM	1/2	20616	24	4	41472	10368	≥ 2
	20	75	0	12	16QAM	1/2	21384	24	4	43200	10800	≥ 2
	20	80	0	12	16QAM	1/2	22920	24	4	46080	11520	≥ 2
	20	81	0	12	16QAM	1/2	22920	24	4	46656	11664	≥ 2
	20	90	0	12	16QAM	2/5	20616	24	4	51840	12960	≥ 2
	20	96	0	12	16QAM	2/5	22152	24	4	55296	13824	≥ 2
Note 1: If more than one Code Block is present, an additional CRC sequence of L = 24 Bits is attached to each Code Block (otherwise L = 0 Bit)												
Note 2: As per Table 4.2-2 in TS 36.211 [4]												

Table A.2.3.2.2-1a: Reference Channels for 16QAM with partial RB allocation UE UL category 0

Parameter	Ch BW	Allocated RBs	UDL Configuration (Note 2)	DFT-OFDM Symbols per Sub-Frame	Mod'n	Target Coding rate	Payload size for Sub-Frame 2, 3, 7, 8	Transport block CRC	Number of code blocks per Sub-Frame (Note 1)	Total number of bits per Sub-Frame for Sub-Frame 2, 3, 7, 8	Total symbols per Sub-Frame for Sub-Frame 2, 3, 7, 8	UE UL Category
Unit	MHz						Bits	Bits		Bits		
	1.4 - 20	1	1	12	16QAM	3/4	408	24	1	576	144	0
	1.4 - 20	2		12	16QAM	3/4	840	24	1	1152	288	0
	1.4 - 20	4		12	16QAM	2/5	904	24	1	2304	576	0
Note 1: If more than one Code Block is present, an additional CRC sequence of L = 24 Bits is attached to each Code Block (otherwise L = 0 Bit)												
Note 2: As per Table 4.2-2 in TS 36.211 [4]												

Table A.2.3.2.2-1b: Reference Channels for 16QAM with partial RB allocation UE UL category M1

Parameter	Ch BW	Allocated RBs	UDL Configuration (Note 2)	DFT-OFDM Symbols per Sub-Frame	Mod'n	Target Coding rate	Payload size for Sub-Frame 2, 3, 7, 8	Transport block CRC	Number of code blocks per Sub-Frame (Note 1)	Total number of bits per Sub-Frame for Sub-Frame 2, 3, 7, 8	Total symbols per Sub-Frame for Sub-Frame 2, 3, 7, 8	UE Category
Unit	MHz						Bits	Bits		Bits		
	1.4 - 20	1	1	12	16QAM	1/2	256	24	1	576	144	M1
	1.4 - 20	2	1	12	16QAM	1/2	552	24	1	1152	288	M1
	1.4 - 20	3	1	12	16QAM	1/2	840	24	1	1728	432	M1
	1.4 - 20	4	1	12	16QAM	2/5	904	24	1	2304	576	M1
Note 1: If more than one Code Block is present, an additional CRC sequence of L = 24 Bits is attached to each Code Block (otherwise L = 0 Bit).												
Note 2: As per Table 4.2-2 in TS 36.211 [4].												

Table A.2.3.2.2-1c: Reference Channels for 16QAM with partial RB allocation UE UL category M2

Parameter	Ch BW	Allocated RBs	UDL Configuration (Note 2)	DFT-OFDM Symbols per Sub-Frame	Mod'n	Target Coding rate	Payload size for Sub-Frame 2, 3, 7, 8	Transport block CRC	Number of code blocks per Sub-Frame (Note 1)	Total number of bits per Sub-Frame for Sub-Frame 2, 3, 7, 8	Total symbols per Sub-Frame for Sub-Frame 2, 3, 7, 8	UE Category
Unit	MHz						Bits	Bits		Bits		
	1.4 - 20	1	1	12	16QAM	1/2	256	24	1	576	144	M2
	1.4 - 20	2	1	12	16QAM	1/2	552	24	1	1152	288	M2
	1.4 - 20	3	1	12	16QAM	1/2	840	24	1	1728	432	M2
	1.4 - 20	4	1	12	16QAM	1/2	1128	24	1	2304	576	M2
	1.4 - 20	5	1	12	16QAM	1/2	1416	24	1	2880	720	M2
	3 - 20	6	1	12	16QAM	1/2	1736	24	1	3456	864	M2
	3 - 20	9	1	12	16QAM	1/2	2600	24	1	5184	1296	M2
	3 - 20	12	1	12	16QAM	1/2	3496	24	1	6912	1728	M2
	5 - 20	15	1	12	16QAM	1/2	4264	24	1	8640	2160	M2
	5 - 20	18	1	12	16QAM	1/2	5160	24	1	10368	2592	M2
	5 - 20	21	1	12	16QAM	1/2	5992	24	1	12096	3024	M2
	5 - 20	24	1	12	16QAM	1/2	6968	24	2	13824	3456	M2

Note 1: If more than one Code Block is present, an additional CRC sequence of L = 24 Bits is attached to each Code Block (otherwise L = 0 Bit).

Note 2: As per Table 4.2-2 in TS 36.211 [4].

A.2.3.2.3 64-QAM

**Table A.2.3.2.3-1: Reference Channels for 64-QAM with partial RB allocation**

Parameter	Ch BW	Allocated RBs	DFT-OFDM Symbols per Sub-Frame	Mod'n	Target Coding rate	Payload size	Transport block CRC	Number of code blocks per Sub-Frame (Note 1)	Total number of bits per Sub-Frame	Total symbols per Sub-Frame	UE Category (Note 3)	UE UL Category (Note 3)
Unit	MHz					Bits	Bits		Bits			
	1.4 - 20	1	12	64QAM	3/4	616	24	1	864	144	5,8	5, 8, 13, 14
	1.4 - 20	2	12	64QAM	3/4	1256	24	1	1728	288	5,8	5, 8, 13, 14
	1.4 - 20	3	12	64QAM	3/4	1864	24	1	2592	432	5,8	5, 8, 13, 14
	1.4 - 20	4	12	64QAM	3/4	2536	24	1	3456	576	5,8	5, 8, 13, 14
	1.4 - 20	5	12	64QAM	3/4	3112	24	1	4320	720	5,8	5, 8, 13, 14
	3-20	6	12	64QAM	3/4	3752	24	1	5184	864	5,8	5, 8, 13, 14
	3-20	8	12	64QAM	3/4	5160	24	1	6912	1152	5,8	5, 8, 13, 14
	3-20	9	12	64QAM	3/4	5736	24	1	7776	1296	5,8	5, 8, 13, 14
	3-20	10	12	64QAM	3/4	6200	24	2	8640	1440	5,8	5, 8, 13, 14
	3-20	12	12	64QAM	3/4	7480	24	2	10368	1728	5,8	5, 8, 13, 14
	5-20	15	12	64QAM	3/4	9528	24	2	12960	2160	5,8	5, 8, 13, 14
	5-20	16	12	64QAM	3/4	10296	24	2	13824	2304	5,8	5, 8, 13, 14
	5-20	18	12	64QAM	3/4	11448	24	2	15552	2592	5,8	5, 8, 13, 14
	5-20	20	12	64QAM	3/4	12576	24	3	17280	2880	5,8	5, 8, 13, 14
	5-20	24	12	64QAM	3/4	15264	24	3	20736	3456	5,8	5, 8, 13, 14
	10-20	25	12	64QAM	3/4	15840	24	3	21600	3600	5,8	5, 8, 13, 14
	10-20	27	12	64QAM	3/4	16992	24	3	23328	3888	5,8	5, 8, 13, 14
	10-20	30	12	64QAM	3/4	19080	24	4	25920	4320	5,8	5, 8, 13, 14
	10-20	32	12	64QAM	3/4	20616	24	4	27648	4608	5,8	5, 8, 13, 14
	10-20	36	12	64QAM	3/4	22920	24	4	31104	5184	5,8	5, 8, 13, 14
	10-20	40	12	64QAM	3/4	25456	24	5	34560	5760	5,8	5, 8, 13, 14
	10-20	45	12	64QAM	3/4	28336	24	5	38880	6480	5,8	5, 8, 13, 14
	10-20	48	12	64QAM	3/4	30576	24	5	41472	6912	5,8	5, 8, 13, 14
	15 - 20	50	12	64QAM	3/4	31704	24	6	43200	7200	5,8	5, 8, 13, 14
	15 - 20	54	12	64QAM	3/4	34008	24	6	46656	7776	5,8	5, 8, 13, 14
	15 - 20	60	12	64QAM	3/4	37888	24	7	51840	8640	5,8	5, 8, 13, 14
	15 - 20	64	12	64QAM	3/4	40576	24	7	55296	9216	5,8	5, 8, 13, 14
	15 - 20	72	12	64QAM	3/4	45352	24	8	62208	10368	5,8	5, 8, 13, 14
	20	75	12	64QAM	3/4	46888	24	8	64800	10800	5,8	5, 8, 13, 14
	20	80	12	64QAM	3/4	51024	24	9	69120	11520	5,8	5, 8, 13, 14
	20	81	12	64QAM	3/4	51024	24	9	69984	11664	5,8	5, 8, 13, 14
	20	90	12	64QAM	3/4	51024	24	9	77760	12960	5,8	5, 8, 13, 14

	20	96	12	64QAM	3/4	61664	24	11	82944	13824	5,8	5, 8, 13, 14
Note 1:	If more than one Code Block is present, an additional CRC sequence of L = 24 Bits is attached to each Code Block (otherwise L = 0 Bit)											
Note 2:	As per Table 4.2-2 in TS 36.211 [4].											
Note 3:	If UE does not report UE UL category, then the applicability of reference channel is determined by UE category. If UE reports UE UL category, then the applicability of reference channel is determined by UE UL category											

A.2.3.2.4 256 QAM

Table A.2.3.2.4-1: Reference Channels for 256 QAM with partial RB allocation

Parameter	Ch BW	Allocated RBs	UDL Configuration (Note 2)	DFT-OFDM Symbols per Sub-Frame	Mod'n	Target Coding rate	Payload size	Trans-port block CRC	Number of code blocks per Sub-Frame (Note 1)	Total number of bits per Sub-Frame	Total symbols per Sub-Frame	UE UL Category
Unit	MHz						Bits	Bits		Bits		
	1.4 - 20	1	1	12	256QAM	3/4	840	24	1	1152	144	≥ 15
	1.4 - 20	2	1	12	256QAM	3/4	1672	24	1	2304	288	≥ 15
	1.4 - 20	3	1	12	256QAM	3/4	2536	24	1	3456	432	≥ 15
	1.4 - 20	4	1	12	256QAM	3/4	3368	24	1	4608	576	≥ 15
	1.4 - 20	5	1	12	256QAM	3/4	4264	24	1	5760	720	≥ 15
	3-20	6	1	12	256QAM	3/4	5160	24	1	6912	864	≥ 15
	3-20	8	1	12	256QAM	3/4	6712	24	2	9216	1152	≥ 15
	3-20	9	1	12	256QAM	3/4	7736	24	2	10368	1296	≥ 15
	3-20	10	1	12	256QAM	3/4	8504	24	2	11520	1440	≥ 15
	3-20	12	1	12	256QAM	3/4	10296	24	2	13824	1728	≥ 15
	5-20	15	1	12	256QAM	3/4	12960	24	3	17280	2160	≥ 15
	5-20	16	1	12	256QAM	3/4	13536	24	3	18432	2304	≥ 15
	5-20	18	1	12	256QAM	3/4	15264	24	3	20736	2592	≥ 15
	5-20	20	1	12	256QAM	3/4	16992	24	3	23040	2880	≥ 15
	5-20	24	1	12	256QAM	3/4	20616	24	4	27648	3456	≥ 15
	10-20	25	1	12	256QAM	3/4	21384	24	4	28800	3600	≥ 15
	10-20	27	1	12	256QAM	3/4	22920	24	4	31104	3888	≥ 15
	10-20	30	1	12	256QAM	3/4	25456	24	5	34560	4320	≥ 15
	10-20	32	1	12	256QAM	3/4	27376	24	5	36864	4608	≥ 15
	10-20	36	1	12	256QAM	3/4	30576	24	6	41472	5184	≥ 15
	10-20	40	1	12	256QAM	3/4	34008	24	6	46080	5760	≥ 15
	10-20	45	1	12	256QAM	3/4	37888	24	7	51840	6480	≥ 15
	10-20	48	1	12	256QAM	3/4	40576	24	8	55296	6912	≥ 15
	15 - 20	50	1	12	256QAM	3/4	42368	24	8	57600	7200	≥ 15
	15 - 20	54	1	12	256QAM	3/4	46888	24	8	62208	7776	≥ 15
	15 - 20	60	1	12	256QAM	3/4	51024	24	9	69120	8640	≥ 15
	15 - 20	64	1	12	256QAM	3/4	55056	24	9	73728	9216	≥ 15
	15 - 20	72	1	12	256QAM	3/4	61664	24	11	82944	10368	≥ 15
	20	75	1	12	256QAM	3/4	63776	24	11	86400	10800	≥ 15
	20	80	1	12	256QAM	3/4	68808	24	12	92160	11520	≥ 15
	20	81	1	12	256QAM	3/4	68808	24	12	93312	11664	≥ 15
	20	90	1	12	256QAM	3/4	76208	24	13	103680	12960	≥ 15
	20	96	1	12	256QAM	3/4	81176	24	14	110592	13824	≥ 15
Note 1:	If more than one Code Block is present, an additional CRC sequence of L = 24 Bits is attached to each Code Block (otherwise L = 0 Bit)											
Note 2:	As per Table 4.2-2 in TS 36.211 [4]											

A.2.3.3 Void

Table A.2.3.3-1: Void

## A.2.4 Reference measurement channels for UE category NB1

**Table A.2.4-1 Reference Channels for UE category NB1**

Parameter	Value						
	3.75	3.75	15	15	15	15	15
Sub-carrier spacing (kHz)	1	1	1	1	3	6	12
Number of tone	$\pi/2$ BPSK	$\pi/4$ QPSK	$\pi/2$ BPSK	$\pi/4$ QPSK	QPSK	QPSK	QPSK
Number of NPUSCH repetition	1	1	1	1	1	1	1
IMCS / ITBS	0 / 0	3 / 3	0 / 0	3 / 3	5 / 5	5 / 5	5 / 5
Payload size (bits)	32	40	32	40	72	72	72
Allocated resource unit	2	1	2	1	1	1	1
Code rate (target)	1/3	1/3	1/3	1/3	1/3	1/3	1/3
Code rate (effective)	0.29	0.33	0.29	0.33	0.33	0.33	0.33
Transport block CRC (bits)	24	24	24	24	24	24	24
Code block CRC size (bits)	0	0	0	0	0	0	0
Number of code blocks – C	1	1	1	1	1	1	1
Total number of bits per resource unit	96	192	96	192	288	288	288
Total symbols per resource unit	96	96	96	96	144	144	144
Tx time (ms)	64	32	16	8	4	2	1

NOTE 1: If more than one Code Block is present, an additional CRC sequence of L = 24 Bits is attached to each Code Block (otherwise L = 0 Bit)

NOTE 2: Parameters related to NPUSCH format 1 scheduling are defined in Table A.2.4-2.

NOTE 3: NPDCCH is not transmitted in the subframes used for transmission of SI messages.

NOTE 4: SI messages transmission should be prioritized over NPDCCH transmission in case of collision. NPDCCH transmission is postponed until the next NB-IoT downlink subframe in case NPDCCH transmission occurs in a non NB-IoT downlink subframe, where an NB-IoT downlink subframe is a subframe that does not contain NPSS/NSSS/NPBCH/SIB1-NB transmission.

**Table A.2.4-2: NPDCCH configuration for NPUSCH format 1 scheduling**

Parameter	Unit	Value
DCI format		DCI format N0
NPDCCH format		1
Scheduling delay ( $I_{\text{Delay}}$ )		0
DCI subframe repetition number		00
$R_{\text{max}}$ ( <i>npdcch-NumRepetitions</i> )		1
G ( <i>NPDCCH-startSF-USS</i> )		8
$\alpha_{\text{offset}}$ ( <i>npdcch-Offset-USS</i> )		1/4

## A.2.5 Reference measurement channels for LAA

### A.2.5.1 Full RB allocation

#### A.2.5.1.1 QPSK

**Table A.2.5.1.1-1: Reference Channels for QPSK with full RB allocation**

Parameter	Unit	Value	
Channel bandwidth	MHz	10	20
Allocated resource blocks		50	100
DFT-OFDM Symbols per Sub-Frame		12	12
Modulation		QPSK	QPSK
Target Coding rate		1/3	1/6
Payload size	Bits	5160	4584
Transport block CRC	Bits	24	24
Number of code blocks per Sub-Frame (Note 1)		1	1
Total number of bits per Sub-Frame	Bits	14400	28800
Total symbols per Sub-Frame		7200	14400
UE Category		≥ 1	≥ 1
Note 1: If more than one Code Block is present, an additional CRC sequence of L = 24 Bits is attached to each Code Block (otherwise L = 0 Bit)			

#### A.2.5.1.2 16QAM

**Table A.2.5.1.2-1: Reference Channels for 16QAM with full RB allocation**

Parameter	Unit	Value	
Channel bandwidth	MHz	10	20
Allocated resource blocks		50	100
DFT-OFDM Symbols per Sub-Frame		12	12
Modulation		16QAM	16QAM
Target Coding rate		3/4	1/3
Payload size	Bits	21384	19848
Transport block CRC	Bits	24	24
Number of code blocks per Sub-Frame (Note 1)		4	4
Total number of bits per Sub-Frame	Bits	28800	57600
Total symbols per Sub-Frame		7200	14400
UE Category		≥ 2	≥ 2
Note 1: If more than one Code Block is present, an additional CRC sequence of L = 24 Bits is attached to each Code Block (otherwise L = 0 Bit)			

## A.2.5.1.3 64QAM

Table A.2.5.1.3-1: Reference Channels for 64QAM with full RB allocation

Parameter	Unit	Value	
Channel bandwidth	MHz	10	20
Allocated resource blocks		50	100
DFT-OFDM Symbols per Sub-Frame		12	12
Modulation		64QAM	64QAM
Target Coding rate		3/4	3/4
Payload size	Bits	31704	63776
Transport block CRC	Bits	24	24
Number of code blocks per Sub-Frame (Note 1)		8	11
Total number of bits per Sub-Frame	Bits	43200	86400
Total symbols per Sub-Frame		7200	14400
UE Category (Note 2)		5,8	5,8
UE UL Category (Note 2)		5,8,13, 14	5,8,13, 14
Note 1: If more than one Code Block is present, an additional CRC sequence of L = 24 Bits is attached to each Code Block (otherwise L = 0 Bit)			
Note 2: If UE does not report UE UL category, then the applicability of reference channel is determined by UE category. If UE reports UE UL category, then the applicability of reference channel is determined by UE UL category.			

## A.2.5.2 Partial RB allocation

For each channel bandwidth, various partial RB allocations are specified. The number of allocated RBs is chosen according to values specified in the Tx and Rx requirements.

## A.2.5.2.1 QPSK

Table A.2.5.2.1-1: Reference Channels for QPSK with partial RB allocation

Parameter	Ch BW	Allocated RBs	DFT-OFDM Symbols per Sub-Frame	Mod'n	Target Coding rate	Payload size	Transport block CRC	Number of code blocks per Sub-Frame (Note 1)	Total number of bits per Sub-Frame	Total symbols per Sub-Frame	UE Category
Unit	MHz					Bits	Bits		Bits		
	10 - 20	10	12	QPSK	1/3	872	24	1	2880	1440	≥ 1
	10 - 20	20	12	QPSK	1/3	1736	24	1	5760	2880	≥ 1
	10 - 20	30	12	QPSK	1/3	2664	24	1	8640	4320	≥ 1
	10 - 20	40	12	QPSK	1/3	4136	24	1	11520	5760	≥ 1
	20	50	12	QPSK	1/3	5160	24	1	14400	7200	≥ 1
	20	60	12	QPSK	1/4	4264	24	1	17280	8640	≥ 1
	20	70	12	QPSK	1/4	4968	24	1	20160	10080	≥ 1
	20	80	12	QPSK	1/5	4776	24	1	23040	11520	≥ 1
	20	90	12	QPSK	1/6	4008	24	1	25920	12960	≥ 1
Note 1: If more than one Code Block is present, an additional CRC sequence of L = 24 Bits is attached to each Code Block (otherwise L = 0 Bit)											
Note 2: For the channel bandwidth of 10MHz, the allocated RBs are distributed over the channel bandwidth at the RB index = {N, N+5, N+10, ..., N+45 for N = 0, ..., N <sub>Interface</sub> -1 } where N <sub>Interface</sub> is 1, ..., 4 for the allocated RBs of 10, ..., 40, respectively.											
Note 3: For the channel bandwidth of 20MHz, the allocated RBs are distributed over the channel bandwidth at the RB index = {N, N+10, N+20, ..., N+90 for N = 0, ..., N <sub>Interface</sub> -1 } where N <sub>Interface</sub> is 1, ..., 9 for the allocated RBs of 10, ..., 90, respectively.											



A.2.5.2.2 16QAM

Table A.2.5.2.2-1: Reference Channels for 16QAM with partial RB allocation

Parameter	Ch BW	Allocated RBs	DFT-OFDM Symbols per Sub-Frame	Mod'n	Target Coding rate	Payload size	Transport block CRC	Number of code blocks per Sub-Frame (Note 1)	Total number of bits per Sub-Frame	Total symbols per Sub-Frame	UE Category
Unit	MHz					Bits	Bits		Bits		
	10 - 20	10	12	16QAM	3/4	4264	24	1	5760	1440	≥ 2
	10 - 20	20	12	16QAM	1/3	4008	24	1	11520	2880	≥ 2
	10 - 20	30	12	16QAM	3/4	12960	24	3	17280	4320	≥ 2
	10 - 20	40	12	16QAM	3/4	16992	24	3	23040	5760	≥ 2
	20	50	12	16QAM	3/4	21384	24	4	28800	7200	≥ 2
	20	60	12	16QAM	2/3	23688	24	4	34560	8640	≥ 2
	20	70	12	16QAM	1/2	19848	24	4	40320	10080	≥ 2
	20	80	12	16QAM	1/2	22920	24	4	46080	11520	≥ 2
	20	90	12	16QAM	2/5	20616	24	4	51840	12960	≥ 2

Note 1: If more than one Code Block is present, an additional CRC sequence of L = 24 Bits is attached to each Code Block (otherwise L = 0 Bit)

Note 2: For the channel bandwidth of 10Mhz, the allocated RBs are distributed over the channel bandwidth at the RB index = {N, N+5, N+10, ..., N+45 for N = 0, ..., N<sub>Interface</sub>-1 } where N<sub>Interface</sub> is 1, ..., 4 for the allocated RBs of 10, ..., 40, respectively.

Note 3: For the channel bandwidth of 20Mhz, the allocated RBs are distributed over the channel bandwidth at the RB index = {N, N+10, N+20, ..., N+90 for N = 0, ..., N<sub>Interface</sub>-1 } where N<sub>Interface</sub> is 1, ..., 9 for the allocated RBs of 10, ..., 90, respectively.

A.2.5.2.3 64QAM

Table A.2.5.2.3-1: Reference Channels for 64QAM with partial RB allocation

Parameter	Ch BW	Allocated RBs	DFT-OFDM Symbols per Sub-Frame	Mod'n	Target Coding rate	Payload size	Transport block CRC	Number of code blocks per Sub-Frame (Note 1)	Total number of bits per Sub-Frame	Total symbols per Sub-Frame	UE Category (Note 2)	UE UL Category (Note 2)
Unit	MHz					Bits	Bits		Bits			
	10 - 20	10	12	64QAM	3/4	6200	24	2	8640	1440	5,8	5, 8, 13, 14
	10 - 20	20	12	64QAM	3/4	12576	24	3	17280	2880	5,8	5, 8, 13, 14
	10 - 20	30	12	64QAM	3/4	19080	24	4	25920	4320	5,8	5, 8, 13, 14
	10 - 20	40	12	64QAM	3/4	25456	24	5	34560	5760	5,8	5, 8, 13, 14
	20	50	12	64QAM	3/4	31704	24	6	43200	7200	5,8	5, 8, 13, 14
	20	60	12	64QAM	3/4	37888	24	7	51840	8640	5,8	5, 8, 13, 14
	20	70	12	64QAM	3/4	43816	24	4	60480	10080	5,8	5, 8, 13, 14
	20	80	12	64QAM	3/4	51024	24	9	69120	11520	5,8	5, 8, 13, 14
	20	90	12	64QAM	2/3	51024	24	9	77760	12960	5,8	5, 8, 13, 14

Note 1: If more than one Code Block is present, an additional CRC sequence of L = 24 Bits is attached to each Code Block (otherwise L = 0 Bit)

Note 2: If UE does not report UE UL category, then the applicability of reference channel is determined by UE category. If UE reports UE UL category, then the applicability of reference channel is determined by UE UL category

Note 3: For the channel bandwidth of 10Mhz, the allocated RBs are distributed over the channel bandwidth at the RB index = {N, N+5, N+10, ..., N+45 for N = 0, ..., N<sub>Interface</sub>-1 } where N<sub>Interface</sub> is 1, ..., 4 for the allocated RBs of 10, ..., 40, respectively.

Note 4: For the channel bandwidth of 20Mhz, the allocated RBs are distributed over the channel bandwidth at the RB index = {N, N+10, N+20, ..., N+90 for N = 0, ..., N<sub>Interface</sub>-1 } where N<sub>Interface</sub> is 1, ..., 9 for the allocated RBs of 10, ..., 90, respectively.

## A.3 DL reference measurement channels

### A.3.1 General

The number of available channel bits varies across the sub-frames due to PBCH and PSS/SSS overhead. The payload size per sub-frame is varied in order to keep the code rate constant throughout a frame.

Unless otherwise stated, no user data is scheduled on subframes #5 in order to facilitate the transmission of system information blocks (SIB).

The algorithm for determining the payload size  $A$  is as follows; given a desired coding rate  $R$  and radio block allocation  $N_{RB}$

1. Calculate the number of channel bits  $N_{ch}$  that can be transmitted during the first transmission of a given sub-frame.
2. Find  $A$  such that the resulting coding rate is as close to  $R$  as possible, that is,

$$\min |R - (A + 24 * (N_{CB} + 1)) / N_{ch}|, \text{ where } N_{CB} = \begin{cases} 0, & \text{if } C = 1 \\ C, & \text{if } C > 1 \end{cases}$$

subject to

- a)  $A$  is a valid TB size according to section 7.1.7 of TS 36.213 [6] assuming an allocation of  $N_{RB}$  resource blocks.
  - b)  $C$  is the number of Code Blocks calculated according to section 5.1.2 of TS 36.212 [5].
3. If there is more than one  $A$  that minimizes the equation above, then the larger value is chosen per default and the chosen code rate should not exceed 0.93.
  4. For TDD, the measurement channel is based on DL/UL configuration ratio of 2DL+DwPTS (12 OFDM symbol): 2UL

#### A.3.1.1 Overview of DL reference measurement channels

In Table A.3.1.1-1 to A.3.1.1-1V are listed the DL reference measurement channels specified in annexes A.3.2 to A.3.15 of this release of TS 36.101. This table is informative and serves only to a better overview. The reference for the concrete reference measurement channels and corresponding implementation's parameters as to be used for requirements are annexes A.3.2 to A.3.15 as appropriate.

Table A.3.1.1-1: Overview of DL reference measurement channels (FDD, Receiver requirements)

Duplex	Table	Name	BW	Mod	TCR	RB	RB Off set	UE Cat eg	Notes
FDD	Table A.3.2-1		1.4	QPSK	1/3	6		≥ 1	
FDD	Table A.3.2-1		3	QPSK	1/3	15		≥ 1	
FDD	Table A.3.2-1		5	QPSK	1/3	25		≥ 1	
FDD	Table A.3.2-1		10	QPSK	1/3	50		≥ 1	
FDD	Table A.3.2-1		15	QPSK	1/3	75		≥ 1	
FDD	Table A.3.2-1		20	QPSK	1/3	100		≥ 1	
FDD / HD-FDD	Table A.3.2-1a		1.4	QPSK	1/3	6		-	UE DL Category 0
FDD / HD-FDD	Table A.3.2-1a		3	QPSK	1/3	14		-	UE DL Category 0
FDD / HD-FDD	Table A.3.2-1a		5	QPSK	1/3	14		-	UE DL Category 0
FDD / HD-FDD	Table A.3.2-1a		10	QPSK	1/3	14		-	UE DL Category 0
FDD / HD-FDD	Table A.3.2-1a		15	QPSK	1/3	14		-	UE DL Category 0
FDD / HD-FDD	Table A.3.2-1a		20	QPSK	1/3	14		-	UE DL Category 0
FDD / HD-FDD	Table A.3.2-1b		1.4	QPSK	1/3	4		M1	
FDD / HD-FDD	Table A.3.2-1b		3	QPSK	1/3	4		M1	
FDD / HD-FDD	Table A.3.2-1b		5	QPSK	1/3	4		M1	
FDD / HD-FDD	Table A.3.2-1b		10	QPSK	1/3	4		M1	
FDD / HD-FDD	Table A.3.2-1b		15	QPSK	1/3	4		M1	
FDD / HD-FDD	Table A.3.2-1b		20	QPSK	1/3	4		M1	
HD-FDD	Table A.3.2-1c		0.2	QPSK	1/3	1		NB1	
HD-FDD	Table A.3.2-1d		0.2	QPSK	1/3	1		NB1	
FDD / HD-FDD	Table A.3.2-1h		1.4	QPSK	1/3	4		M2	
FDD / HD-FDD	Table A.3.2-1h		3	QPSK	1/3	8		M2	
FDD / HD-FDD	Table A.3.2-1h		5	QPSK	1/3	16		M2	
FDD / HD-FDD	Table A.3.2-1h		10	QPSK	1/3	16		M2	
FDD / HD-FDD	Table A.3.2-1h		15	QPSK	1/3	16		M2	
FDD / HD-FDD	Table A.3.2-1h		20	QPSK	1/3	16		M2	

Table A.3.1.1-1A: Overview of DL reference measurement channels (TDD, Receiver requirements)

Duplex	Table	Name	BW	Mod	TCR	RB	RB Off set	UE Cat eg	Notes
TDD	Table A.3.2-2		1.4	QPSK	1/3	6		≥ 1	
TDD	Table A.3.2-2		3	QPSK	1/3	15		≥ 1	
TDD	Table A.3.2-2		5	QPSK	1/3	25		≥ 1	
TDD	Table A.3.2-2		10	QPSK	1/3	50		≥ 1	
TDD	Table A.3.2-2		15	QPSK	1/3	75		≥ 1	
TDD	Table A.3.2-2		20	QPSK	1/3	100		≥ 1	
TDD	Table A.3.2-2a		1.4	QPSK	1/3	6		-	UE DL Category 0
TDD	Table A.3.2-2a		3	QPSK	1/3	14		-	UE DL Category 0
TDD	Table A.3.2-2a		5	QPSK	1/3	14		-	UE DL Category 0
TDD	Table A.3.2-2a		10	QPSK	1/3	14		-	UE DL Category 0
TDD	Table A.3.2-2a		15	QPSK	1/3	14		-	UE DL Category 0
-	Table A.3.2-2a		20	QPSK	1/3	14		-	UE DL Category 0
TDD Band 46	Table A.3.2-2c		20	QPSK	1/3	100		≥ 3	
TDD	Table A.3.2-2b		1.4	QPSK	1/3	4		M1	
TDD	Table A.3.2-2b		3	QPSK	1/3	4		M1	
TDD	Table A.3.2-2b		5	QPSK	1/3	4		M1	
TDD	Table A.3.2-2b		10	QPSK	1/3	4		M1	
TDD	Table A.3.2-2b		15	QPSK	1/3	4		M1	
TDD	Table A.3.2-2b		20	QPSK	1/3	4		M1	
TDD	Table A.3.2-2d		1.4	QPSK	1/3	4		M2	
TDD	Table A.3.2-2d		3	QPSK	1/3	8		M2	
TDD	Table A.3.2-2d		5	QPSK	1/3	16		M2	
TDD	Table A.3.2-2d		10	QPSK	1/3	16		M2	
TDD	Table A.3.2-2d		15	QPSK	1/3	16		M2	
TDD	Table A.3.2-2d		20	QPSK	1/3	16		M2	

**Table A.3.1.1-1B: Overview of DL reference measurement channels (FDD, Receiver requirements, Maximum input level)**

Duplex	Table	Name	BW	Mod	TCR	RB	RB Off set	UE Cat eg	Notes
<b>UE Categories <math>\geq 3</math></b>									
FDD	Table A.3.2-3		1.4	64QAM	3/4	6		-	
FDD	Table A.3.2-3		3	64QAM	3/4	15		-	
FDD	Table A.3.2-3		5	64QAM	3/4	25		-	
FDD	Table A.3.2-3		10	64QAM	3/4	50		-	
FDD	Table A.3.2-3		15	64QAM	3/4	75		-	
FDD	Table A.3.2-3		20	64QAM	3/4	100		-	
<b>UE Category 1</b>									
FDD	Table A.3.2-3a		1.4	64QAM	3/4	6		-	
FDD	Table A.3.2-3a		3	64QAM	3/4	15		-	
FDD	Table A.3.2-3a		5	64QAM	3/4	18		-	
FDD	Table A.3.2-3a		10	64QAM	3/4	17		-	
FDD	Table A.3.2-3a		15	64QAM	3/4	17		-	
FDD	Table A.3.2-3a		20	64QAM	3/4	17		-	
<b>UE Category 2</b>									
FDD	Table A.3.2-3b		1.4	64QAM	3/4	6		-	
FDD	Table A.3.2-3b		3	64QAM	3/4	15		-	
FDD	Table A.3.2-3b		5	64QAM	3/4	25		-	
FDD	Table A.3.2-3b		10	64QAM	3/4	50		-	
FDD	Table A.3.2-3b		15	64QAM	3/4	75		-	
FDD	Table A.3.2-3b		20	64QAM	3/4	83		-	
<b>UE DL Category 0</b>									
FDD	Table A.3.2-3c		1.4	64QAM	3/4	2		-	
FDD	Table A.3.2-3c		3	64QAM	3/4	2		-	
FDD	Table A.3.2-3c		5	64QAM	3/4	2		-	
FDD	Table A.3.2-3c		10	64QAM	3/4	2		-	
FDD	Table A.3.2-3c		15	64QAM	3/4	2		-	
FDD	Table A.3.2-3c		20	64QAM	3/4	2		-	
<b>UE Categories 11/12 and UE DL categories <math>\geq 11</math></b>									
FDD	Table A.3.2-5		1.4	256QAM	4/5	6		-	
FDD	Table A.3.2-5		3	256QAM	4/5	15		-	
FDD	Table A.3.2-5		5	256QAM	4/5	25		-	
FDD	Table A.3.2-5		10	256QAM	4/5	50		-	
FDD	Table A.3.2-5		15	256QAM	4/5	75		-	
FDD	Table A.3.2-5		20	256QAM	4/5	100		-	
<b>UE DL Category M1</b>									
FDD/HD-FDD	Table A.3.2-3d		1.4	16QAM	3/5	2		-	
FDD/HD-FDD	Table A.3.2-3d		3	16QAM	3/5	2		-	
FDD/HD-FDD	Table A.3.2-3d		5	16QAM	3/5	2		-	
FDD/HD-FDD	Table A.3.2-3d		10	16QAM	3/5	2		-	
FDD/HD-FDD	Table A.3.2-3d		15	16QAM	3/5	2		-	
FDD/HD-FDD	Table A.3.2-3d		20	16QAM	3/5	2		-	
<b>UE DL Category M2</b>									
FDD/HD-FDD	Table A.3.2-3e		1.4	16QAM	3/5	2		-	

FDD/HD-FDD	Table A.3.2-3e		3	16QAM	3/5	8		-	
FDD/HD-FDD	Table A.3.2-3e		5	16QAM	1/2	15		-	
FDD/HD-FDD	Table A.3.2-3e		10	16QAM	1/2	15		-	
FDD/HD-FDD	Table A.3.2-3e		15	16QAM	1/2	15		-	
FDD/HD-FDD	Table A.3.2-3e		20	16QAM	1/2	15		-	
<b>UE DL category 20 and UE DL categories <math>\geq</math> 22</b>									
FDD	Table A.3.2-8		1.4	1024QAM	4/5	6		-	
FDD	Table A.3.2-8		3	1024QAM	4/5	15		-	
FDD	Table A.3.2-8		5	1024QAM	4/5	25		-	
FDD	Table A.3.2-8		10	1024QAM	4/5	50		-	
FDD	Table A.3.2-8		15	1024QAM	4/5	75		-	
FDD	Table A.3.2-8		20	1024QAM	4/5	100		-	

**Table A.3.1.1-1C: Overview of DL reference measurement channels (TDD, Receiver requirements, Maximum input level)**



Duplex	Table	Name	BW	Mod	TCR	RB	RB Off set	UE Cat eg	Notes
<b>UE Categories <math>\geq 3</math></b>									
TDD	Table A.3.2-4		1.4	64QAM	3/4	6		-	
TDD	Table A.3.2-4		3	64QAM	3/4	15		-	
TDD	Table A.3.2-4		5	64QAM	3/4	25		-	
TDD	Table A.3.2-4		10	64QAM	3/4	50		-	
TDD	Table A.3.2-4		15	64QAM	3/4	75		-	
TDD	Table A.3.2-4		20	64QAM	3/4	100		-	
TDD Band 46	Table A.3.2-4d		20	64QAM	3/4	100		-	
<b>UE Category 1</b>									
TDD	Table A.3.2-4a		1.4	64QAM	3/4	6		-	
TDD	Table A.3.2-4a		3	64QAM	3/4	15		-	
TDD	Table A.3.2-4a		5	64QAM	3/4	18		-	
TDD	Table A.3.2-4a		10	64QAM	3/4	17		-	
TDD	Table A.3.2-4a		15	64QAM	3/4	17		-	
TDD	Table A.3.2-4a		20	64QAM	3/4	17		-	
<b>UE Category 2</b>									
TDD	Table A.3.2-4b		1.4	64QAM	3/4	6		-	
TDD	Table A.3.2-4b		3	64QAM	3/4	15		-	
TDD	Table A.3.2-4b		5	64QAM	3/4	25		-	
TDD	Table A.3.2-4b		10	64QAM	3/4	50		-	
TDD	Table A.3.2-4b		15	64QAM	3/4	75		-	
TDD	Table A.3.2-4b		20	64QAM	3/4	83		-	
<b>UE DL Category 0</b>									
TDD	Table A.3.2-4c		1.4	64QAM	3/4	2		-	
TDD	Table A.3.2-4c		3	64QAM	3/4	2		-	
TDD	Table A.3.2-4c		5	64QAM	3/4	2		-	
TDD	Table A.3.2-4c		10	64QAM	3/4	2		-	
TDD	Table A.3.2-4c		15	64QAM	3/4	2		-	
TDD	Table A.3.2-4c		20	64QAM	3/4	2		-	
<b>UE Categories 11/12 and UE DL categories <math>\geq 11</math></b>									
TDD	Table A.3.2-6		1.4	256QAM	4/5	6		-	
TDD	Table A.3.2-6		3	256QAM	4/5	15		-	
TDD	Table A.3.2-6		5	256QAM	4/5	25		-	
TDD	Table A.3.2-6		10	256QAM	4/5	50		-	
TDD	Table A.3.2-6		15	256QAM	4/5	75		-	
TDD	Table A.3.2-6		20	256QAM	4/5	100		-	
TDD Band 46	Table A.3.2-7		20	256QAM	4/5	100		-	
<b>UE DL Category M1</b>									
TDD	Table A.3.2-4e		1.4	16QAM	3/5	2		-	
TDD	Table A.3.2-4e		3	16QAM	3/5	2		-	
TDD	Table A.3.2-4e		5	16QAM	3/5	2		-	
TDD	Table A.3.2-4e		10	16QAM	3/5	2		-	
TDD	Table A.3.2-4e		15	16QAM	3/5	2		-	
TDD	Table A.3.2-4e		20	16QAM	3/5	2		-	
<b>UE DL Category M2</b>									

TDD	Table A.3.2-4f		1.4	16QAM	3/5	2		-	
TDD	Table A.3.2-4f		3	16QAM	3/5	8		-	
TDD	Table A.3.2-4f		5	16QAM	1/2	15		-	
TDD	Table A.3.2-4f		10	16QAM	1/2	15		-	
TDD	Table A.3.2-4f		15	16QAM	1/2	15		-	
TDD	Table A.3.2-4f		20	16QAM	1/2	15		-	
<b>UE DL category 20 and UE DL categories ≥ 22</b>									
TDD	Table A.3.2-9		1.4	1024QAM	4/5	6		-	
TDD	Table A.3.2-9		3	1024QAM	4/5	15		-	
TDD	Table A.3.2-9		5	1024QAM	4/5	25		-	
TDD	Table A.3.2-9		10	1024QAM	4/5	50		-	
TDD	Table A.3.2-9		15	1024QAM	4/5	75		-	
TDD	Table A.3.2-9		20	1024QAM	4/5	100		-	
TDD Band 46	Table A.3.2-10		20	1024QAM	4/5	100		-	

**Table A.3.1.1-1D: Overview of DL reference measurement channels (FDD, PDSCH Performance, Single-antenna transmission (CRS))**

Duplex	Table	Name	BW	Mod	TCR	RB	RB Off set	UE Cat eg	Notes
FDD	Table A.3.3.1-1	R.4 FDD	1.4	QPSK	1/3	6		≥ 1	
FDD	Table A.3.3.1-1	R.42 FDD	20	QPSK	1/3	100		≥ 1	
FDD	Table A.3.3.1-1	R.42-1 FDD	3	QPSK	1/3	15		≥ 1	
FDD	Table A.3.3.1-1	R.42-2 FDD	5	QPSK	1/3	25		≥ 1	
FDD	Table A.3.3.1-1	R.42-3 FDD	15	QPSK	1/3	75		≥ 1	
FDD	Table A.3.3.1-1	R.2 FDD	10	QPSK	1/3	50		≥ 1	
FDD	Table A.3.3.1-2	R.3-1 FDD	5	16QAM	1/2	25		≥ 1	
FDD	Table A.3.3.1-2	R.3 FDD	10	16QAM	1/2	50		≥ 2	
FDD	Table A.3.3.1-3	R.5 FDD	3	64QAM	3/4	15		≥ 1	
FDD	Table A.3.3.1-3	R.6 FDD	5	64QAM	3/4	25		≥ 2	
FDD	Table A.3.3.1-3	R.7 FDD	10	64QAM	3/4	50		≥ 2	
FDD	Table A.3.3.1-3	R.8 FDD	15	64QAM	3/4	75		≥ 2	
FDD	Table A.3.3.1-3	R.9 FDD	20	64QAM	3/4	100		≥ 3	
FDD	Table A.3.3.1-3a	R.6-1 FDD	5	64QAM	3/4	18		≥ 1	
FDD	Table A.3.3.1-3a	R.7-1 FDD	10	64QAM	3/4	17		≥ 1	
FDD	Table A.3.3.1-3a	R.8-1 FDD	15	64QAM	3/4	17		≥ 1	
FDD	Table A.3.3.1-3a	R.9-1 FDD	20	64QAM	3/4	17		≥ 1	
FDD	Table A.3.3.1-3a	R.9-2 FDD	20	64QAM	3/4	83		≥ 2	
FDD	Table A.3.3.1-6	R.41 FDD	10	QPSK	1/10	50		≥ 1	
<b>Single PRB (Channel edge)</b>									
FDD	Table A.3.3.1-4	R.0 FDD	3	16QAM	1/2	1		≥ 1	
FDD	Table A.3.3.1-4	R.1 FDD	10 / 20	16QAM	1/2	1		≥ 1	
<b>Single PRB (MBSFN Configuration)</b>									
FDD	Table A.3.3.1-5	R.29 FDD	10	16QAM	1/2	1		≥ 1	

**Table A.3.1.1-E: Overview of DL reference measurement channels (PDSCH Performance: Carrier aggregation with power imbalance)**

Duplex	Table	Name	BW	Mod	TCR	RB	RB Off set	UE Cat eg	Notes
<b>FDD</b>									
FDD	Table A.3.3.1-7	R.49 FDD	20	64QAM	0.84-0.87	100		≥ 5	
FDD	Table A.3.3.1-7	R.49-1 FDD	10	64QAM	0.84-0.87	50		≥ 2	
FDD	Table A.3.3.1-7	R.49-2 FDD	5	64QAM	0.84-0.86	25		≥ 2	
<b>TDD</b>									
TDD	Table A.3.4.1-7	R.49 TDD	20	64QAM	0.81-0.87	100		≥ 5	
TDD	Table A.3.4.1-7	R.49-1 TDD	15	64QAM	0.80-0.86	75		≥ 3	

**Table A.3.1.1-F: Overview of DL reference measurement channels (FDD, PDSCH Performance, Multi-antenna transmission (CRS))**

Duplex	Table	Name	BW	Mod	TCR	RB	RB Off set	UE Cat eg	Notes
<b>Two antenna ports</b>									
FDD	Table A.3.3.2.1-1	R.10 FDD	10	QPSK	1/3	50		≥ 1	
FDD	Table A.3.3.2.1-1	R.11 FDD	10	16QAM	1/2	50		≥ 2	
FDD	Table A.3.3.2.1-1	R.11-1 FDD	10	16QAM	1/2	50		≥ 2	
FDD	Table A.3.3.2.1-1	R.11-2 FDD	5	16QAM	1/2	25		≥ 1	
FDD	Table A.3.3.2.1-1	R.11-3 FDD	10	16QAM	1/2	40		≥ 1	
FDD	Table A.3.3.2.1-1	R.11-4 FDD	10	QPSK	1/2	50		≥ 1	
FDD	Table A.3.3.2.1-9	R.11-13 FDD	10	16QAM	1/2	50		≥ 2	
FDD	Table A.3.3.2.1-1	R.30 FDD	20	16QAM	1/2	100		≥ 2	
FDD	Table A.3.3.2.1-1	R.30-1 FDD	15	16QAM	1/2	75		≥ 2	
FDD	Table A.3.3.2.1-1	R.35 FDD	10	64QAM	1/2	50		≥ 2	
FDD	Table A.3.3.2.1-1	R.35-1 FDD	20	64QAM	0.39	100		4	
FDD	Table A.3.3.2.1-1	R.35-2 FDD	15	64QAM	0.39	75		≥ 2	
FDD	Table A.3.3.2.1-1	R.35-3 FDD	10	64QAM	0.39	50		≥ 2	
FDD	Table A.3.3.2.1-2	R.35-4 FDD	10	64QAM	0.47	50		≥ 2	
FDD	Table A.3.3.2.1-2	R.46 FDD	10	QPSK		50		≥ 1	
FDD	Table A.3.3.2.1-2	R.47 FDD	10	16QAM		50		≥ 1	
FDD	Table A.3.3.2.1-7	R.47-1 FDD	5	16QAM		25		≥ 1	
FDD	Table A.3.3.2.1-7	R.47-2 FDD	15	16QAM		75		≥ 1	
FDD	Table A.3.3.2.1-7	R.47-3 FDD	20	16QAM		100		≥ 1	
FDD	Table A.3.3.2.1-2	R.11-5 FDD	1.4	16QAM	1/2	6		≥ 1	
FDD	Table A.3.3.2.1-2	R.11-6 FDD	3	16QAM	1/2	15		≥ 1	
FDD	Table A.3.3.2.1-2	R.11-7 FDD	15	16QAM	1/2	75		≥ 2	
FDD	Table A.3.3.2.1-2	R.11-8 FDD	10	QPSK	3/5	50		≥ 2	
FDD	Table A.3.3.2.1-2	R.11-9 FDD	10	QPSK	0.58	50		≥ 1	
FDD	Table A.3.3.2.1-2	R.11-10 FDD	10	QPSK	0.67	50		≥ 1	
FDD	Table A.3.3.2.1-2	R.10-2 FDD	5	QPSK	1/3	25		≥ 1	
FDD	Table A.3.3.2.1-2	R.10-3 FDD	10	16QAM	0.58	50		≥ 2	

FDD	Table A.3.3.2.1-2	R.65 FDD	10	256QAM	0.55	50		11-15	
FDD	Table A.3.3.2.1-3	R.62 FDD	10	16QAM	1/2	3		0	
FDD	Table A.3.3.2.1-3	R.63 FDD	10	64QAM	1/2	1		0	
FDD	Table A.3.3.2.1-4	R.79 FDD	10	16QAM	1/2	3		M1, M2, $\geq 0$	
FDD	Table A.3.3.2.1-5	R.81 FDD	10	QPSK	1/10	6		M1, $\geq 0$	
FDD	Table A.3.3.2.1-6	R.84 FDD	10	16QAM	1/2	39		$\geq 1$	
FDD	Table A.3.3.2.1-6	R.aa FDD	10	QPSK	0.6-0.65	50		$\geq 1$	
FDD	Table A.3.3.2.1-6	R.bb FDD	10	16QAM	0.3-0.32	50		$\geq 2$	
FDD	Table A.3.3.2.1-6	R.87 FDD	10	64QAM	0.39	50		$\geq 1$	
FDD	Table A.3.3.2.1-6	R.87-1 FDD	10	16QAM	0.44	50		$\geq 1$	
FDD	Table A.3.3.2.1-6	R.87-2 FDD	5	64QAM	0.39	25		$\geq 1$	
FDD	Table A.3.3.2.1-6	R.87-3 FDD	15	64QAM	0.39	75		$\geq 1$	
FDD	Table A.3.3.2.1-6	R.87-4 FDD	20	64QAM	0.39	100		$\geq 1$	
FDD	Table A.3.3.2.1-8	R.90 FDD	10	QPSK	1/3	18		M2	
FDD	Table A.3.3.2.1-8	R.91 FDD	10	QPSK	1/10	18		M2	
FDD	Table A.3.3.2.1-8	R.92-1 FDD	10	QPSK	1/2	36		$\geq 1$	
FDD	Table A.3.3.2.1-8	R.92-2 FDD	10	QPSK	1/2	36		$\geq 1$	
FDD	Table A.3.3.2.1-4	R.103 FDD	10	QPSK	1/3	3		M1, M2	
FDD	Table A.3.3.2.1-4	R.104 FDD	10	64QAM	0.4	3		M1, M2	
<b>Four antenna ports</b>									
FDD	Table A.3.3.2.2-1	R.12 FDD	1.4	QPSK	1/3	6		$\geq 1$	
FDD	Table A.3.3.2.2-1	R.13 FDD	10	QPSK	1/3	50		$\geq 1$	
FDD	Table A.3.3.2.2-1	R.14 FDD	10	16QAM	1/2	50		$\geq 2$	
FDD	Table A.3.3.2.2-1	R.14-1 FDD	10	16QAM	1/2	6		$\geq 1$	
FDD	Table A.3.3.2.2-1	R.14-2 FDD	10	16QAM	1/2	3		$\geq 1$	
FDD	Table A.3.3.2.2-1	R.14-3 FDD	20	16QAM	1/2	100		$\geq 2$	
FDD	Table A.3.3.2.2-1	R.36 FDD	10	64QAM	1/2	50		$\geq 2$	
FDD	Table A.3.3.2.2-1	R.14-4 FDD	1.4	16QAM	1/2	6		$\geq 1$	
FDD	Table A.3.3.2.2-1	R.14-5 FDD	3	16QAM	1/2	15		$\geq 1$	
FDD	Table A.3.3.2.2-1	R.14-6 FDD	5	16QAM	1/2	25		$\geq 1$	
FDD	Table A.3.3.2.2-1	R.14-7 FDD	15	16QAM	1/2	75		$\geq 2$	
FDD	Table A.3.3.2.2-2	R.72 FDD	10	256QAM	0.62	50		$\geq 11$	
FDD	Table A.3.3.2.2-2	R.72-1 FDD	5	256QAM	0.62	25		$\geq 11$	
FDD	Table A.3.3.2.2-2	R.72-2 FDD	15	256QAM	0.62	75		$\geq 11$	
FDD	Table A.3.3.2.2-2	R.72-3 FDD	20	256QAM	0.62	100		$\geq 11$	
FDD	Table A.3.3.2.2-2	R.73 FDD	10	64QAM	0.43	50		$\geq 5$	
FDD	Table A.3.3.2.2-2	R.74 FDD	10	16QAM	1/2	50		$\geq 5$	
FDD	Table A.3.3.2.2-3	R.74-1 FDD	5	16QAM	1/2	25		$\geq 5$	
FDD	Table A.3.3.2.2-3	R.74-2 FDD	15	16QAM	1/2	75		$\geq 5$	
FDD	Table A.3.3.2.2-3	R.74-3 FDD	20	16QAM	1/2	100		$\geq 5$	
FDD	Table A.3.3.2.2-2	R.85 FDD	10	64QAM	1/2	24		$\geq 1$	
FDD	Table A.3.3.2.2-2	R.93 FDD	10	64QAM	0.52	24		$\geq 1$	
FDD	Table A.3.3.2.2-4	R.95 FDD	10	16QAM	1/2	3		M2	
FDD	Table A.3.3.2.2-3	R.xx1 FDD	10	1024QAM		50		20, $\geq 22$	UE DL Category

**Table A.3.1.1-1G: Overview of DL reference measurement channels (FDD, PDSCH Performance (UE specific RS))**

Duplex	Table	Name	BW	Mod	TCR	RB	RB Off set	UE Cat eg	Notes
<b>Without CSI-RS</b>									
FDD	Table A.3.3.3.0-1	R.70 FDD	10	QPSK	0.65	50		≥ 1	
FDD	Table A.3.3.3.0-1	R.71 FDD	10	16QAM	0.6	50		≥ 2	
FDD	Table A.3.3.3.0-2	R.80 FDD	10	QPSK	1/3	6		M1, ≥ 0	
<b>Two antenna ports (CSI-RS)</b>									
FDD	Table A.3.3.3.1-1	R.51 FDD	10	16QAM	1/2	50		≥ 2	
FDD	Table A.3.3.3.1-1	R.51-1 FDD	10	16QAM	0.54	50		≥ 2	
FDD	Table A.3.3.3.1-1	R.51-2 FDD	5	16QAM	0.54	25		≥ 2	
FDD	Table A.3.3.3.1-1	R.51-3 FDD	15	16QAM	0.54	75		≥ 2	
FDD	Table A.3.3.3.1-1	R.51-4 FDD	20	16QAM	0.54	100		≥ 2	

FDD	Table A.3.3.3.1-1	R.76 FDD	10	QPSK		50		≥ 2	
FDD	Table A.3.3.3.1-3	R.76-1 FDD	5	QPSK		25		≥ 2	
FDD	Table A.3.3.3.1-3	R.76-2 FDD	15	QPSK		75		≥ 2	
FDD	Table A.3.3.3.1-3	R.76-3 FDD	20	QPSK		100		≥ 2	
FDD	Table A.3.3.3.1-3	R.76-4 FDD	5	QPSK		25		≥ 2	
FDD	Table A.3.3.3.1-3	R.76-5 FDD	10	QPSK		50		≥ 2	
FDD	Table A.3.3.3.1-3	R.76-6 FDD	15	QPSK		75		≥ 2	
FDD	Table A.3.3.3.1-3	R.76-7 FDD	20	QPSK		100		≥ 2	
FDD	Table A.3.3.3.1-1	R.86 FDD	10	QPSK	1/3	50		≥ 1	
FDD	Table A.3.3.3.1-1	R.86A FDD	10	QPSK	1/3	50		≥ 1	
FDD	Table A.3.3.3.1-1	R.94 FDD	10	QPSK	2/3	24		≥ 1	
<b>Two antenna ports (CSI-RS, non Quasi Co-located)</b>									
FDD	Table A.3.3.3.1-2	R.52 FDD	10	64QAM	1/2	50		≥ 2	
FDD	Table A.3.3.3.1-2	R.52-1 FDD	10	16QAM	0.54	50		≥ 2	
FDD	Table A.3.3.3.1-2	R.53 FDD	10	64QAM	1/2	50		≥ 2	
FDD	Table A.3.3.3.1-2	R.54 FDD	10	16QAM	1/2	50		≥ 2	
FDD	Table A.3.3.3.1-2	R.97 FDD	10	16QAM	1/2	50		≥ 2	
<b>Four antenna ports (CSI-RS)</b>									
FDD	Table A.3.3.3.2-1	R.43 FDD	10	QPSK	1/3	50		≥ 1	
FDD	Table A.3.3.3.2-1	R.50 FDD	10	64QAM	1/2	50		≥ 2	
FDD	Table A.3.3.3.2-2	R.50A-1 FDD	10	64QAM	1/2	50		≥ 2	
FDD	Table A.3.3.3.2-2	R.44 FDD	10	QPSK	1/3	50		≥ 1	
FDD	Table A.3.3.3.2-2	R.45 FDD	10	16QAM	1/2	50		≥ 2	
FDD	Table A.3.3.3.2-2	R.45-1 FDD	10	16QAM	1/2	39		≥ 1	
FDD	Table A.3.3.3.2-1	R.45A-1 FDD	10	16QAM	1/2	50		≥ 2	
FDD	Table A.3.3.3.2-2	R.45A-2 FDD	10	16QAM	1/2	50		≥ 2	
FDD	Table A.3.3.3.2-1	R.48 FDD	10	QPSK		50		≥ 1	
FDD	Table A.3.3.3.2-2	R.60 FDD	10	QPSK	1/2	50		≥ 1	
FDD	Table A.3.3.3.2-3	R.64 FDD	10	QPSK	1/3	6		0	
FDD	Table A.3.3.3.2-1	R.66 FDD	10	256QAM	0.77	50		11-15	
FDD	Table A.3.3.3.2-4	R.69 FDD	10	QPSK	0.74-0.8	50		≥ 1	
FDD	Table A.3.3.3.2-1	R.75 FDD	10	16QAM	0.57	50		≥ 5	
FDD	Table A.3.3.3.2-1	R.75A FDD	10	16QAM	0.51	50		≥ 5	
FDD	Table A.3.3.3.2-1	R.cc FDD	10	16QAM	0.64	50		≥ 2	
FDD	Table A.3.3.3.2-1	R.xx2 FDD	10	1024QAM		50		20, ≥ 22	UE DL Category
<b>Four antenna ports (CSI-RS, non Quasi Co-located)</b>									
FDD	Table A.3.3.3.2-5	R.98 FDD	10	16QAM	1/2	50		≥ 2	
FDD	Table A.3.3.3.2-5	R.99 FDD	10	16QAM	1/2	50		≥ 2	
FDD	Table A.3.3.3.2-6	R.100 FDD	10	16QAM	1/2	50		≥ 2	
<b>Eight antenna ports (CSI-RS)</b>									
FDD	Table A.3.3.3.2A-1	R.50A-2 FDD	10	64QAM	1/2	50		≥ 2	
FDD	Table A.3.3.3.2A-1	R.50A-3 FDD	10	64QAM	1/2	50		≥ 2	
FDD	Table A.3.3.3.2A-2	R.108 FDD	10	QPSK	1/2	4		≥ 1	
<b>Twelve antenna ports (CSI-RS)</b>									
FDD	Table A.3.3.3.3-1	R.77 FDD	10	64QAM	1/2	50		≥ 2	
<b>Sixteen antenna ports (CSI-RS)</b>									
FDD	Table A.3.3.3.4-1	R.78 FDD	10	16QAM	1/2	50		≥ 2	

Twenty-four antenna ports (CSI-RS)								
FDD	Table A.3.3.3.5-1	R.88 FDD	10	16QAM	1/2	50		≥ 2
FDD	Table A.3.3.3.5-1	R.88A FDD	10	16QAM	1/2	50		≥ 2
Thirty-two antenna ports (CSI-RS)								
FDD	Table A.3.3.3.6-1	R.89 FDD	10	64QAM	1/2	50		≥ 2

**Table A.3.1.1-1H: Overview of DL reference measurement channels (TDD, PDSCH Performance, Single-antenna transmission (CRS))**

Duplex	Table	Name	BW	Mod	TCR	RB	RB Off set	UE Cat eg	Notes
TDD	Table A.3.4.1-1	R.4 TDD	1.4	QPSK	1/3	6		≥ 1	
TDD	Table A.3.4.1-1	R.42 TDD	20	QPSK	1/3	100		≥ 1	
TDD	Table A.3.4.1-1	R.2 TDD	10	QPSK	1/3	50		≥ 1	
TDD	Table A.3.4.1-1	R.2A TDD	10	QPSK	1/3	50		≥ 1	
TDD	Table A.3.4.1-1	R.42-1 TDD	3	QPSK	1/3	15		≥ 1	
TDD	Table A.3.4.1-1	R.42-2 TDD	5	QPSK	1/3	25		≥ 1	
TDD	Table A.3.4.1-1	R.42-3 TDD	15	QPSK	1/3	75		≥ 1	
TDD	Table A.3.4.1-2	R.3-1 TDD	5	16QAM	1/2	25		≥ 1	
TDD	Table A.3.4.1-2	R.3 TDD	10	16QAM	1/2	50		≥ 2	
TDD	Table A.3.4.1-3	R.5 TDD	3	64QAM	3/4	15		≥ 1	
TDD	Table A.3.4.1-3	R.6 TDD	5	64QAM	3/4	25		≥ 2	
TDD	Table A.3.4.1-3	R.7 TDD	10	64QAM	3/4	50		≥ 2	
TDD	Table A.3.4.1-3	R.8 TDD	15	64QAM	3/4	75		≥ 2	
TDD	Table A.3.4.1-3	R.9 TDD	20	64QAM	3/4	100		≥ 3	
TDD	Table A.3.4.1-3a	R.6-1 TDD	5	64QAM	3/4	18		≥ 1	
TDD	Table A.3.4.1-3a	R.7-1 TDD	10	64QAM	3/4	17		≥ 1	
TDD	Table A.3.4.1-3a	R.8-1 TDD	15	64QAM	3/4	17		≥ 1	
TDD	Table A.3.4.1-3a	R.9-1 TDD	20	64QAM	3/4	17		≥ 1	
TDD	Table A.3.4.1-3a	R.9-2 TDD	20	64QAM	3/4	83		≥ 2	
TDD	Table A.3.4.1-6	R.41 TDD	10	QPSK	1/10	50		≥ 1	
Single PRB (Channel edge)									
TDD	Table A.3.4.1-4	R.0 TDD	3	16QAM	1/2	1		≥ 1	
TDD	Table A.3.4.1-4	R.1 TDD	10 / 20	16QAM	1/2	1		≥ 1	
Single PRB (MBSFN Configuration)									
TDD	Table A.3.4.1-5	R.29 TDD	10	16QAM	1/2	1		≥ 1	

**Table A.3.1.1-1I: Overview of DL reference measurement channels (TDD, PDSCH Performance, Multi-antenna transmission (CRS))**

Duplex	Table	Name	BW	Mod	TCR	RB	RB Off set	UE Cat eg	Notes
<b>Two antenna ports</b>									
TDD	Table A.3.4.2.1-1	R.10 TDD	10	QPSK	1/3	50		≥ 1	
TDD	Table A.3.4.2.1-1	R.11 TDD	10	16QAM	1/2	50		≥ 2	
TDD	Table A.3.4.2.1-1	R.11-1 TDD	10	16QAM	1/2	50		≥ 2	
TDD	Table A.3.4.2.1-1	R.11-2 TDD	5	16QAM	1/2	25		≥ 1	
TDD	Table A.3.4.2.1-1	R.11-3 TDD	10	16QAM	1/2	40		≥ 1	
TDD	Table A.3.4.2.1-1	R.11-4 TDD	10	QPSK	1/2	50		≥ 1	
TDD	Table A.3.4.2.1-11	R.11-13 TDD	10	16QAM	1/2	50		≥ 2	
TDD	Table A.3.4.2.1-1	R.30 TDD	20	16QAM	1/2	100		≥ 2	
TDD	Table A.3.4.2.1-1	R.30-1 TDD	20	16QAM	1/2	100		≥ 2	
TDD	Table A.3.4.2.1-1	R.30-2 TDD	20	16QAM	1/2	100		3	
TDD	Table A.3.4.2.1-1	R.35 TDD	10	64QAM	1/2	50		≥ 2	
TDD	Table A.3.4.2.1-1	R.35-1 TDD	20	64QAM	0.39	100		4	
TDD	Table A.3.4.2.1-2	R.35-2 TDD	10	64QAM	0.47	50		≥ 2	
TDD	Table A.3.4.2.1-2	R.46 TDD	10	QPSK		50		≥ 1	
TDD	Table A.3.4.2.1-2	R.47 TDD	10	16QAM		50		≥ 1	
TDD	Table A.3.4.2.1-9	R.47-1 TDD	5	16QAM		25		≥ 1	
TDD	Table A.3.4.2.1-9	R.47-2 TDD	15	16QAM		75		≥ 1	
TDD	Table A.3.4.2.1-9	R.47-3 TDD	20	16QAM		100		≥ 1	
TDD	Table A.3.4.2.1-2	R.11-5 TDD	1.4	16QAM	1/2	6		≥ 1	
TDD	Table A.3.4.2.1-2	R.11-6 TDD	3	16QAM	1/2	15		≥ 1	
TDD	Table A.3.4.2.1-2	R.11-7 TDD	5	16QAM	1/2	25		≥ 1	
TDD	Table A.3.4.2.1-2	R.11-8 TDD	10	16QAM	1/2	50		≥ 2	
TDD	Table A.3.4.2.1-2	R.11-9 TDD	15	16QAM	1/2	75		≥ 2	
TDD	Table A.3.4.2.1-2	R.11-10 TDD	10	QPSK	3/5	50		≥ 2	
TDD	Table A.3.4.2.1-2	R.11-11 TDD	10	QPSK	0.48-0.58	50		≥ 1	
TDD	Table A.3.4.2.1-2	R.11-12 TDD	10	QPSK	0.54-0.66	50		≥ 1	
TDD	Table A.3.4.2.1-2	R.10-3 TDD	10	16QAM	0.57-0.58	50		≥ 1	



TDD	Table A.3.4.2.1-3	R.62 TDD	10	16QAM	1/2	3		0	
TDD	Table A.3.4.2.1-3	R.63 TDD	10	64QAM	1/2	1		0	
TDD	Table A.3.4.2.1-4	R.65 TDD	20	256QAM	0.6	100		11-15	
TDD	Table A.3.4.2.1-5	R.67 TDD	10	16QAM	0.4	50		≥ 1	
TDD	Table A.3.4.2.1-6	R.79 TDD	10	16QAM	1/2	3		M1, M2, ≥ 0	
TDD	Table A.3.4.2.1-7	R.81 TDD	10	QPSK	1/10	6		M1, ≥ 0	
TDD	Table A.3.4.2.1-4	R.84 TDD	10	16QAM	1/2	39		≥ 1	
TDD	Table A.3.4.2.1-8	R.aa TDD	10	QPSK	0.54-0.64	50		≥ 1	
TDD	Table A.3.4.2.1-8	R.bb TDD	10	16QAM	0.27-0.32	50		≥ 2	
TDD	Table A.3.4.2.1-8	R.87 TDD	10	64QAM	0.39	50		≥ 1	
TDD	Table A.3.4.2.1-8	R.87-1 TDD	10	16QAM	0.44	50		≥ 1	
TDD	Table A.3.4.2.1-8	R.87-2 TDD	5	64QAM	0.39	25		≥ 1	
TDD	Table A.3.4.2.1-8	R.87-3 TDD	15	64QAM	0.39	75		≥ 1	
TDD	Table A.3.4.2.1-8	R.87-4 TDD	20	64QAM	0.39	100		≥ 1	
TDD	Table A.3.4.2.1-10	R.90 TDD	10	QPSK	1/3	18		M2	
TDD	Table A.3.4.2.1-10	R.91 TDD	10	QPSK	1/10	18		M2	
TDD	Table A.3.4.2.1-10	R.92-1 TDD	10	QPSK	1/2	36		≥ 1	
TDD	Table A.3.4.2.1-10	R.92-2 TDD	10	QPSK	1/2	36		≥ 1	
TDD	Table A.3.4.2.1-6	R.103 TDD	10	QPSK	1/3	3		M1, M2	
TDD	Table A.3.4.2.1-6	R.104 TDD	10	64QAM	0.4	3		M1, M2	
<b>Four antenna ports</b>									
TDD	Table A.3.4.2.2-1	R.12 TDD	1.4	QPSK	1/3	6		≥ 1	
TDD	Table A.3.4.2.2-1	R.13 TDD	10	QPSK	1/3	50		≥ 1	
TDD	Table A.3.4.2.2-1	R.14 TDD	10	16QAM	1/2	50		≥ 2	
TDD	Table A.3.4.2.2-1	R.14-1 TDD	10	16QAM	1/2	6		≥ 1	
TDD	Table A.3.4.2.2-1	R.14-2 TDD	10	16QAM	1/2	3		≥ 1	
TDD	Table A.3.4.2.2-1	R.43 TDD	20	16QAM	1/2	100		≥ 2	
TDD	Table A.3.4.2.2-1	R.36 TDD	10	64QAM	1/2	50		≥ 2	
TDD	Table A.3.4.2.2-1	R.43-1 TDD	1.4	16QAM	1/2	6		≥ 1	
TDD	Table A.3.4.2.2-1	R.43-2 TDD	3	16QAM	1/2	15		≥ 1	
TDD	Table A.3.4.2.2-1	R.43-3 TDD	5	16QAM	1/2	25		≥ 1	
TDD	Table A.3.4.2.2-1	R.43-4 TDD	10	16QAM	1/2	50		≥ 2	
TDD	Table A.3.4.2.2-1	R.43-5 TDD	15	16QAM	1/2	75		≥ 2	
TDD	Table A.3.4.2.2-2	R.72 TDD	10	256QAM	0.62	50		≥ 11	
TDD	Table A.3.4.2.2-2	R.72-1 TDD	5	256QAM	0.62	25		≥ 11	
TDD	Table A.3.4.2.2-2	R.72-2 TDD	15	256QAM	0.62	75		≥ 11	
TDD	Table A.3.4.2.2-2	R.72-3 TDD	20	256QAM	0.62	100		≥ 11	
TDD	Table A.3.4.2.2-2	R.73 TDD	10	64QAM	0.44	50		≥ 5	
TDD	Table A.3.4.2.2-2	R.74 TDD	10	16QAM	1/2	50		≥ 5	
TDD	Table A.3.4.2.2-3	R.74-1 TDD	5	16QAM	1/2	25		≥ 5	
TDD	Table A.3.4.2.2-3	R.74-2 TDD	15	16QAM	1/2	75		≥ 5	
TDD	Table A.3.4.2.2-3	R.74-3 TDD	20	16QAM	1/2	100		≥ 5	
TDD	Table A.3.4.2.2-2	R.85 TDD	10	64QAM	1/2	24		≥ 1	
TDD	Table A.3.4.2.2-2	R.93 TDD	10	64QAM	0.50	24		≥ 1	
TDD	Table A.3.4.2.2-4	R.95 TDD	10	16QAM	1/2	3		M2	

Table A.3.1.1-1J: Overview of DL reference measurement channels (TDD, PDSCH Performance (DRS))

Duplex	Table	Name	BW	Mod	TCR	RB	RB Off set	UE Cat eg	Notes
<b>Single antenna port</b>									
TDD	Table A.3.4.3.1-1	R.25 TDD	10	QPSK	1/3	50		≥ 1	
TDD	Table A.3.4.3.1-1	R.26 TDD	10	16QAM	1/2	50		≥ 2	
TDD	Table A.3.4.3.1-1	R.26-1 TDD	5	16QAM	1/2	25		≥ 1	
TDD	Table A.3.4.3.1-1	R.27 TDD	10	64QAM	3/4	50		≥ 2	
TDD	Table A.3.4.3.1-1	R.27-1 TDD	10	64QAM	3/4	18		≥ 1	
TDD	Table A.3.4.3.1-1	R.28 TDD	10	16QAM	1/2	1		≥ 1	
TDD	Table A.3.4.3.1-2	R.80 TDD	10	QPSK	1/10	6		M1, ≥ 0	
<b>Two antenna ports</b>									
TDD	Table A.3.4.3.2-1	R.31 TDD	10	QPSK	1/3	50		≥ 1	
TDD	Table A.3.4.3.2-1	R.32 TDD	10	16QAM	1/2	50		≥ 2	
TDD	Table A.3.4.3.2-1	R.32-1 TDD	5	16QAM	1/2	[25]		≥ 1	
TDD	Table A.3.4.3.2-1	R.33 TDD	10	64QAM	3/4	50		≥ 2	
TDD	Table A.3.4.3.2-1	R.33-1 TDD	10	64QAM	3/4	[18]		≥ 1	
TDD	Table A.3.4.3.2-1	R.34 TDD	10	64QAM	1/2	50		≥ 2	
TDD	Table A.3.4.3.2	R.70 TDD	10	QPSK	0.54- 0.65	50		≥ 1	
TDD	Table A.3.4.3.2	R.71 TDD	10	16QAM	0.5- 0.6	50		≥ 2	
TDD	Table A.3.4.3.2-1	R.86 TDD	10	QPSK	1/3	50		≥ 1	

Table A.3.1.1-1K: Overview of DL reference measurement channels (TDD, PDSCH Performance (UE specific RS))

Duplex	Table	Name	BW	Mod	TCR	RB	RB Off set	UE Cat eg	Notes
<b>Two antenna ports (CSI-RS)</b>									
TDD	Table A.3.4.3.3-1	R.51 TDD	10	16QAM	1/2	50		≥ 2	
TDD	Table A.3.4.3.3-1	R.51-1 TDD	10	16QAM	0.57	50		≥ 2	
TDD	Table A.3.4.3.3-1	R.51-2 TDD	5	16QAM	0.57	25		≥ 2	
TDD	Table A.3.4.3.3-1	R.51-3 TDD	15	16QAM	0.57	75		≥ 2	
TDD	Table A.3.4.3.3-1	R.51-4 TDD	20	16QAM	0.57	100		≥ 2	

TDD	Table A.3.4.3.3-1	R.76 FDD	10	QPSK		50		≥ 2	
TDD	Table A.3.4.3.3-3	R.76-1 FDD	5	QPSK		25		≥ 2	
TDD	Table A.3.4.3.3-3	R.76-2 FDD	15	QPSK		75		≥ 2	
TDD	Table A.3.4.3.3-3	R.76-3 FDD	20	QPSK		100		≥ 2	
TDD	Table A.3.4.3.3-3	R.76-4 FDD	5	QPSK		25		≥ 2	
TDD	Table A.3.4.3.3-3	R.76-5 FDD	10	QPSK		50		≥ 2	
TDD	Table A.3.4.3.3-3	R.76-6 FDD	15	QPSK		75		≥ 2	
TDD	Table A.3.4.3.3-3	R.76-7 FDD	20	QPSK		100		≥ 2	
TDD	Table A.3.4.3.1-2	R.76A TDD	10	QPSK	1/3	50		≥ 2	
TDD	Table A.3.4.3.1-2	R.94 TDD	10	QPSK	2/3	24		≥ 1	
<b>Two antenna ports (CSI-RS, non Quasi Co-located)</b>									
TDD	Table A.3.4.3.3-2	R.52 TDD	10	64QAM	1/2	50		≥ 2	
TDD	Table A.3.4.3.3-2	R.52-1 TDD	10	16QAM	0.57	50		≥ 2	
TDD	Table A.3.4.3.3-2	R.53 TDD	10	64QAM	1/2	50		≥ 2	
TDD	Table A.3.4.3.3-2	R.54 TDD	10	16QAM	1/2	50		≥ 2	
TDD	Table A.3.4.3.3-2	R.97 TDD	10	16QAM	1/2	50		≥ 2	
<b>Four antenna ports (CSI-RS)</b>									
TDD	Table A.3.4.3.4-1	R.44 TDD	10	64QAM	1/2	50		≥ 2	
TDD	Table A.3.4.3.4-5	R.44A-1 TDD	10	64QAM	1/2	50		≥ 2	
TDD	Table A.3.4.3.4-1	R.48 TDD	10	QPSK		50		≥ 1	
TDD	Table A.3.4.3.4-2	R.60 TDD	10	QPSK	1/2	50		≥ 1	
TDD	Table A.3.4.3.4-2	R.61 TDD	10	16QAM	1/2	50		≥ 2	
TDD	Table A.3.4.3.4-2	R.61-1 TDD	10	16QAM	1/2	39		≥ 1	
TDD	Table A.3.4.3.4-1	R.61A TDD	10	16QAM	1/2	50		≥ 2	
TDD	Table A.3.4.3.4-3	R.64 TDD	10	QPSK	1/3	6		0	
TDD	Table A.3.4.3.4-1	R.66 TDD	20	256QAM		100		11-15	
TDD	Table A.3.4.3.4-4	R.69 TDD	10	QPSK	0.61-0.8	50		≥ 1	
TDD	Table A.3.4.3.4-1	R.75 TDD	10	16QAM	0.57	50		≥ 5	
TDD	Table A.3.4.3.4-1	R.75A TDD	10	16QAM	0.51	50		≥ 5	
TDD	Table A.3.4.3.4-1	R.cc TDD	10	16QAM		50		≥ 2	
<b>Four antenna ports (CSI-RS, non Quasi Co-located)</b>									
TDD	Table A.3.4.3.4-6	R.98 TDD	10	16QAM	1/2	50		≥ 2	
TDD	Table A.3.4.3.4-6	R.99 TDD	10	16QAM	1/2	50		≥ 2	
TDD	Table A.3.4.3.4-7	R.100 TDD	10	16QAM	1/2	50		≥ 2	
<b>Eight antenna ports (CSI-RS)</b>									
TDD	Table A.3.4.3.5-1	R.50 TDD	10	QPSK	1/3	50		≥ 1	
TDD	Table A.3.4.3.5-2	R.45 TDD	10	16QAM	1/2	50		≥ 2	
TDD	Table A.3.4.3.5-2	R.45-1 TDD	10	16QAM	1/2	39		≥ 1	
TDD	Table A.3.4.3.5-2	R.45A TDD	10	16QAM	1/2	50		≥ 2	
TDD	Table A.3.4.3.5-2	R.45-2 TDD	10	64QAM		50		≥ 2	
TDD	Table A.3.4.3.5-3	R.44A-2 TDD	10	64QAM	1/2	50		≥ 2	
TDD	Table A.3.4.3.5-3	R.44A-3 TDD	10	64QAM	1/2	50		≥ 2	
TDD	Table A.3.4.3.5-1	R.50-3 TDD	5	16QAM	1/2	25		8	
TDD	Table A.3.4.3.5-1	R.50-4 TDD	10	16QAM	1/2	50		8	
TDD	Table A.3.4.3.5-1	R.50-5 TDD	15	16QAM	1/2	75		8	
TDD	Table A.3.4.3.5-1	R.50-6 TDD	20	16QAM	1/2	100		8	
TDD	Table A.3.4.3.5-4	R.108 TDD	10	QPSK	1/2	4		≥ 1	
<b>Twelve antenna ports (CSI-RS)</b>									

TDD	Table A.3.4.3.6-1	R.77 TDD	10	64QAM	1/2	50		≥ 2	
<b>Sixteen antenna ports (CSI-RS)</b>									
TDD	Table A.3.4.3.7-1	R.78 TDD	10	16QAM	1/2	50		≥ 2	
<b>Twenty-four antenna ports (CSI-RS)</b>									
TDD	Table A.3.4.3.8-1	R.88 TDD	10	16QAM	1/2	50		≥ 2	
TDD	Table A.3.4.3.8-1	R.88A TDD	10	16QAM	1/2	50		≥ 2	
<b>Thirty-two antenna ports (CSI-RS)</b>									
TDD	Table A.3.4.3.9-1	R.89 TDD	10	64QAM	1/2	50		≥ 2	

Table A.3.1.1-1L: Overview of DL reference measurement channels (PDCCH / PCFICH Performance)

Duplex	Table	Name	BW	Mod	TCR	RB	RB Off set	UE Cat eg	Notes
<b>FDD</b>									
FDD	Table A.3.5.1-1	R.15 FDD	10	PDCCH					
FDD	Table A.3.5.1-1	R.15-1 FDD	10	PDCCH					
FDD	Table A.3.5.1-1	R.15-2 FDD	10	PDCCH					
FDD	Table A.3.5.1-1	R.16 FDD	10	PDCCH					
FDD	Table A.3.5.1-1	R.16-1 FDD	10	PDCCH					
FDD	Table A.3.5.1-1	R.16-2 FDD	10	PDCCH					
FDD	Table A.3.5.1-1	R.16-3 FDD	10	PDCCH					
FDD	Table A.3.5.1-1	R.16-4 FDD	10	PDCCH					
FDD	Table A.3.5.1-1	R.17 FDD	5	PDCCH					
FDD	Table A.3.5.1-1	R.17-3 FDD	10	PDCCH					
<b>TDD</b>									
TDD	Table A.3.5.2-1	R.15 TDD	10	PDCCH					
TDD	Table A.3.5.2-1	R.15-1 TDD	10	PDCCH					
TDD	Table A.3.5.2-1	R.15-2 TDD	10	PDCCH					
TDD	Table A.3.5.2-1	R.16 TDD	10	PDCCH					
TDD	Table A.3.5.2-1	R.16-1 TDD	10	PDCCH					
TDD	Table A.3.5.2-1	R.16-2 TDD	10	PDCCH					
TDD	Table A.3.5.2-1	R.16-3 TDD	10	PDCCH					
TDD	Table A.3.5.2-1	R.16-4 TDD	10	PDCCH					
TDD	Table A.3.5.2-1	R.17 TDD	5	PDCCH					
TDD	Table A.3.5.2-1	R.17-3 TDD	10	PDCCH					
<b>FS3</b>									
FS3	Table A.3.5.3-1	R.3 FS3	20	PDCCH					
FS3	Table A.3.5.3-2	R.4 FS3	20	PDCCH					

**Table A.3.1.1-1M: Overview of DL reference measurement channels (PHICH Performance)**

Duplex	Table	Name	BW	Mod	TCR	RB	RB Off set	UE Cat eg	Notes
FDD / TDD	Table A.3.6-1	R.18	10	PHICH					
FDD / TDD	Table A.3.6-1	R.19	10	PHICH					
FDD	Table A.3.6.1	R.19-1	5	PHICH					
FDD / TDD	Table A.3.6-1	R.20	5	PHICH					
FDD / TDD	Table A.3.6-1	R.24	10	PHICH					

**Table A.3.1.1-1N: Overview of DL reference measurement channels (PBCH Performance)**

Duplex	Table	Name	BW	Mod	TCR	RB	RB Off set	UE Cat eg	Notes
FDD / TDD	Table A.3.7-1	R.21	1.4	QPSK	40/1920				
FDD / TDD	Table A.3.7-1	R.22	1.4	QPSK	40/1920				
FDD / TDD	Table A.3.7-1	R.23	1.4	QPSK	40/1920				
FDD / TDD	Table A.3.7-1	R.23-1	1.4	QPSK	40/4416				

Table A.3.1.1-10: Overview of DL reference measurement channels (PMCH Performance)

Duplex	Table	Name	BW	Mod	TCR	RB	RB Off set	UE Cat eg	Notes
<b>FDD</b>									
FDD	Table A.3.8.1-1	R.40 FDD	1.4	QPSK	1/3	6		≥ 1	
FDD	Table A.3.8.1-1	R.37 FDD	10	QPSK	1/3	50		≥ 1	
FDD	Table A.3.8.1-2	R.38 FDD	10	16QAM	1/2	50		≥ 1	
FDD	Table A.3.8.1-3	R.39-1 FDD	5	64QAM	2/3	25		≥ 1	
FDD	Table A.3.8.1-3	R.39 FDD	10	64QAM	2/3	50		≥ 2	
FDD	Table A.3.8.1-4	R.81-1 FDD	10	16QAM	1/2	50		≥ 2	
FDD	Table A.3.8.1-4	R.81-2 FDD	10	64QAM	2/3	50		≥ 2	
FDD	Table A.3.8.1-5	R.82-1 FDD	10	16QAM	1/2	50		≥ 2	
FDD	Table A.3.8.1-6	R.83-1 FDD	10	16QAM	1/2	50		≥ 2	
FDD	Table A.3.8.1-6	R.83-2 FDD	10	64QAM	2/3	50		≥ 2	
FDD	Table A.3.8.1-7	R.84-1 FDD	10	16QAM	1/2	50		≥ 2	
FDD	Table A.3.8.1-8	R.85-1 FDD	3	QPSK	1/3	15		≥ 1	
FDD	Table A.3.8.1-8	R.85-2 FDD	5	16QAM	1/2	25		≥ 1	
FDD	Table A.3.8.1-8	R.85-3 FDD	10	64QAM	2/3	50		≥ 2	
FDD	Table A.3.8.1-9	R.106-1 FDD	10	64QAM	0.48	50		≥ 2	
FDD	Table A.3.8.1-9	R.106-2 FDD	10	64QAM	0.52	50		≥ 2	
FDD	Table A.3.8.1-10	R.107 FDD	10	16QAM	0.46	50		≥ 2	
<b>TDD</b>									
TDD	Table A.3.8.2-1	R.40 TDD	1.4	QPSK	1/3	6		≥ 1	
TDD	Table A.3.8.2-1	R.37 TDD	10	QPSK	1/3	50		≥ 1	
TDD	Table A.3.8.2-2	R.38 TDD	10	16QAM	1/2	50		≥ 1	
TDD	Table A.3.8.2-3	R.39-1 TDD	5	64QAM	2/3	25		≥ 1	
TDD	Table A.3.8.2-3	R.39 TDD	10	64QAM	2/3	50		≥ 2	

**Table A.3.1.1-1P: Overview of DL reference measurement channels (Sustained data rate)**

Duplex	Table	Name	BW	Mod	TCR	RB	RB Off set	UE Cat eg	Notes
<b>FDD</b>									
FDD	Table A.3.9.1-1	R.31-1 FDD	10	64QAM	0.40			≥ 1	
FDD	Table A.3.9.1-2	R.31-1A FDD	20	64QAM	0.41			≥ 1	
FDD	Table A.3.9.1-1	R.31-2 FDD	10	64QAM	0.59-0.64			≥ 2	
FDD	Table A.3.9.1-1	R.31-3 FDD	20	64QAM	0.59-0.62			≥ 2	
FDD	Table A.3.9.1-1	R.31-3A FDD	10	64QAM	0.85-0.90			≥ 2	
FDD	Table A.3.9.1-1	R.31-3C FDD	15	64QAM	0.87-0.91			≥ 3	
FDD	Table A.3.9.1-1	R.31-4 FDD	20	64QAM	0.87-0.90			≥ 3	
FDD	Table A.3.9.1-1	R.31-4B FDD	15	64QAM	0.85-0.88			≥ 4	
FDD	Table A.3.9.1-1	R.31-5 FDD	15	64QAM	0.85-0.91			≥ 3	
FDD	Table A.3.9.1-2	R.31-6 FDD	5	64QAM	0.83-0.85			≥ 2	
FDD	Table A.3.9.1-2	R.31-7 FDD	10	64QAM	0.78-0.83			≥ 6	
FDD	Table A.3.9.1-2	R.31-8 FDD	15	64QAM	0.77-0.80			≥ 6	
FDD	Table A.3.9.1-2	R.31-9 FDD	20	64QAM	0.79-0.81			≥ 6	
FDD	Table A.3.9.1-2	R.31-10 FDD	5	64QAM	0.78-0.85			≥ 6	
FDD	Table A.3.9.1-3	R.68 FDD	20	256QAM	0.74-0.85			11-12	
FDD	Table A.3.9.1-3	R.68-1 FDD	15	256QAM	0.74-0.88			11-12	
FDD	Table A.3.9.1-3	R.68-2 FDD	10	256QAM	0.74-0.85			11-12	
FDD	Table A.3.9.1-3	R.68-3 FDD	5	256QAM	0.77-0.85			11-12	
FDD	Table A.3.9.1-3	R.68-4 FDD	10	256QAM	0.78-0.83			11-12	
FDD	Table A.3.9.1-3	R.68-5 FDD	15	256QAM	0.79-0.82			11-12	
FDD	Table A.3.9.1-3	R.68-6 FDD	20	256QAM	0.78-0.80			11-12	
FDD	Table A.3.9.1-3	R.68-7 FDD	5	256QAM	0.77-0.85			11-12	
<b>TDD</b>									
TDD	Table A.3.9.2-1	R.31-1 TDD	10	64QAM	0.40			≥ 1	
TDD	Table A.3.9.2-1	R.31-1A TDD	20	64QAM	0.41			≥ 1	
TDD	Table A.3.9.2-1	R.31-2 TDD	10	64QAM	0.59-0.64			≥ 2	
TDD	Table A.3.9.2-1	R.31-3 TDD	20	64QAM	0.59-0.62			≥ 2	
TDD	Table A.3.9.2-1	R.31-3A TDD	15	64QAM	0.87-0.90			≥ 2	
TDD	Table A.3.9.2-1	R.31-4 TDD	20	64QAM	0.87-0.90			≥ 3	
TDD	Table A.3.9.2-1	R.31-4A TDD	20	64QAM	0.87-0.90			≥ 3	
TDD	Table A.3.9.2-1	R.31-5 TDD	15	64QAM	0.85-0.88			≥ 3	
TDD	Table A.3.9.2-1	R.31-5A TDD	15	64QAM	0.85-0.88			≥ 3	
TDD	Table A.3.9.2-1	R.31-6 TDD	10	64QAM	0.85-0.88			≥ 2	
TDD	Table A.3.9.2-1A	R.31-7 TDD	10	64QAM	0.78-0.82			≥ 6	
TDD	Table A.3.9.2-1A	R.31-8 TDD	15	64QAM	0.77-0.79			≥ 6	
TDD	Table A.3.9.2-1A	R.31-9 TDD	20	64QAM	0.79-0.81			≥ 6	



TDD	Table A.3.9.2-1A	R.31-7 TDD	10	64QAM	0.75-0.85			8	
TDD	Table A.3.9.2-1A	R.31-8 TDD	15	64QAM	0.76-0.84			8	
TDD	Table A.3.9.2-1A	R.31-9 TDD	20	64QAM	0.74-0.85			8	
TDD	Table A.3.9.2-2	R.68 TDD	20	256QAM				11-12	
TDD	Table A.3.9.2-2	R.68-1 TDD	15	256QAM				11-12	
TDD	Table A.3.9.2-2	R.68-2 TDD	10	256QAM				11-12	
TDD	Table A.3.9.2-2	R.68-3 TDD	20	256QAM				11-12	
TDD	Table A.3.9.2-2	R.68-4 TDD	15	256QAM				11-12	
TDD	Table A.3.9.2-3	R.68-5 TDD	10	256QAM	0.78-0.82			11-12	
TDD	Table A.3.9.2-3	R.68-6 TDD	15	256QAM	0.79-0.82			11-12	
TDD	Table A.3.9.2-3	R.68-7 TDD	20	256QAM	0.78-0.80			11-12	
TDD	Table A.3.9.2-3	R.68-8 TDD	10	256QAM	0.70-0.77			8	
TDD	Table A.3.9.2-3	R.68-9 TDD	15	256QAM	0.70-0.76			8	
TDD	Table A.3.9.2-3	R.68-10 TDD	20	256QAM	0.69-0.77			8	
<b>FDD, EPDCCH scheduling</b>									
FDD	Table A.3.9.3-1	R.31E-1 FDD	10	64QAM	0.40-0			≥ 1	
FDD	Table A.3.9.3-1	R.31E-2 FDD	10	64QAM	0.59-0.66			≥ 2	
FDD	Table A.3.9.3-1	R.31E-3 FDD	20	64QAM	0.59-0.63			≥ 2	
FDD	Table A.3.9.1-1	R.31E-3C FDD	15	64QAM	0.87-0.92			≥ 3	
FDD	Table A.3.9.3-1	R.31E-3A FDD	10	64QAM	0.85-0.92			≥ 2	
FDD	Table A.3.9.3-1	R.31E-4 FDD	20	64QAM	0.87-0.91			≥ 3	
FDD	Table A.3.9.1-1	R.31E-4B FDD	15	64QAM	0.87-0.90			≥ 4	
<b>TDD, EPDCCH scheduling</b>									
TDD	Table A.3.9.4-1	R.31E-1 TDD	10	64QAM	0.40-0.41			≥ 1	
TDD	Table A.3.9.4-1	R.31E-2 TDD	10	64QAM	0.59-0.65			≥ 2	
TDD	Table A.3.9.4-1	R.31E-3 TDD	20	64QAM	0.59-0.63			≥ 2	
TDD	Table A.3.9.4-1	R.31E-3A TDD	15	64QAM	0.87-0.92			≥ 2	
TDD	Table A.3.9.4-1	R.31E-4 TDD	20	64QAM	0.87-0.90			≥ 3	

Table A.3.1.1-1Q: Overview of DL reference measurement channels (EPDCCH)

Duplex	Table	Name	BW	Mod	TCR	RB	RB Off set	UE Cat eg	Notes
<b>FDD</b>									
FDD	Table A.3.10.1-1	R.55 FDD	10	EPDCCH					
FDD	Table A.3.10.1-1	R.55-1 FDD	10	EPDCCH					
FDD	Table A.3.10.1-1	R.56 FDD	10	EPDCCH					
FDD	Table A.3.10.1-1	R.57 FDD	10	EPDCCH					
FDD	Table A.3.10.1-1	R.58 FDD	10	EPDCCH					
FDD	Table A.3.10.1-1	R.59 FDD	10	EPDCCH					
<b>TDD</b>									
TDD	Table A.3.10.2-1	R.55 TDD	10	EPDCCH					
TDD	Table A.3.10.2-1	R.55-1 TDD	10	EPDCCH					
TDD	Table A.3.10.2-1	R.56 TDD	10	EPDCCH					
TDD	Table A.3.10.2-1	R.57 TDD	10	EPDCCH					
TDD	Table A.3.10.2-1	R.58 TDD	10	EPDCCH					
TDD	Table A.3.10.2-1	R.59 TDD	10	EPDCCH					

Table A.3.1.1-1R: Overview of DL reference measurement channels (MPDCCH)

Duplex	Table	Name	BW	Mod	TCR	RB	RB Off set	UE Cat eg	Notes
<b>FDD</b>									
FDD	Table A.3.11.1-1	R.82 FDD	10	MPDCCH					
FDD	Table A.3.11.1-1	R.83 FDD	10	MPDCCH					
FDD	Table A.3.11.1-1	R.96 FDD	10	MPDCCH					
<b>TDD</b>									
TDD	Table A.3.11.2-1	R.82 TDD	10	MPDCCH					
TDD	Table A.3.11.2-1	R.83 TDD	10	MPDCCH					
TDD	Table A.3.11.2-1	R.96 TDD	10	MPDCCH					

Table A.3.1.1-1S: Overview of DL reference measurement channels (NPDSCH)

Duplex	Table	Name	BW(KHz)	Mod	TCR	RB	RB Off set	UE Cat eg	Notes
<b>FDD</b>									
HD-FDD	Table A.3.12.1.2-1	R.NB.5 FDD	200	QPSK	1/3			NB1	
HD-FDD	Table A.3.12.1.2-1	R.NB.5-1 FDD	200	QPSK	1/3			NB1	
HD-FDD	Table A.3.12.2.1-1	R.NB.6 FDD	200	QPSK	1/2			NB1	
HD-FDD	Table A.3.12.2.1-1	R.NB.6-1 FDD	200	QPSK	1/3			NB1	

Table A.3.1.1-1T: Overview of DL reference measurement channels (NPDCCH)

Duplex	Table	Name	BW(KHz)	Mod	TCR	RB	RB Off set	UE Cat eg	Notes
<b>FDD</b>									
HD-FDD	Table A.3.13.1-1	R.NB.3 FDD	200	QPSK				NB1	
HD-FDD	Table A.3.13.1-1	R.NB.4 FDD	200	QPSK				NB1	

Table A.3.1.1-1U: Overview of DL reference measurement channels (NPBCH)

Duplex	Table	Name	BW(KHz)	Mod	TCR	RB	RB Off set	UE Cat eg	Notes
<b>FDD</b>									
HD-FDD	Table A.3.14-1	R.NB.1 FDD	200	QPSK				NB1	
HD-FDD	Table A.3.14-1	R.NB.2 FDD	200	QPSK				NB1	

Table A.3.1.1-1V: Overview of DL reference measurement channels (FS3)

Duplex	Table	Name	BW	Mod	TCR	RB	RB Off set	UE Cat eg	Notes
<b>FS3</b>									
FS3	Table A.3.5.1.1-2	R.1 FS3	20	64QAM	0.6	100		≥ 5	
FS3	Table A.3.15.2.1-1	R.2 FS3	20	16QAM	1/2	100		≥ 5	
FS3	Table A.3.9.5-1	R.5 FS3	20	64QAM	0.88-0.89	100		≥ 5	not supporting both initial and end partial SF
FS3	Table A.3.9.5-1	R.6 FS3	20	64QAM	0.77-0.89	100		≥ 5	supporting end partial SF
FS3	Table A.3.9.5-1	R.7 FS3	20	64QAM	0.88-0.90	100		≥ 5	supporting initial partial SF but not supporting end partial SF
FS3	Table A.3.9.5-1	R.8 FS3	20	64QAM	0.79-0.80	100		≥ 5	not supporting both initial and end partial SF
FS3	Table A.3.9.5-1	R.9 FS3	20	64QAM	0.79-0.82	100		≥ 5	supporting end partial SF
FS3	Table A.3.9.5-1	R.10 FS3	20	64QAM	0.79-0.81	100		≥ 5	supporting initial partial SF but not supporting end partial SF
FS3	Table A.3.9.5-2	R.11 FS3	20	256QAM	0.75-0.85	100		≥ 11	not supporting both initial and end partial SF
FS3	Table A.3.9.5-2	R.12 FS3	20	256QAM	0.74-0.85	100		≥ 11	supporting end partial SF
FS3	Table A.3.9.5-2	R.13 FS3	20	256QAM	0.74-0.85	100		≥ 11	supporting initial partial SF but not supporting end partial SF
FS3	Table A.3.9.5-2	R.14 FS3	20	256QAM	0.78-0.79	100		≥ 11	not supporting both initial and end partial SF
FS3	Table A.3.9.5-2	R.15 FS3	20	256QAM	0.74-0.79	100		≥ 11	supporting end partial SF
FS3	Table A.3.9.5-2	R.16 FS3	20	256QAM	0.77-0.79	100		≥ 11	supporting initial partial SF but not supporting end partial SF

**Table A.3.1.1-1W: Overview of DL reference measurement channels (Slot-PDSCH/Subslot-PDSCH)**

Duplex	Table	Name	BW	Mod	TCR	RB	RB Off set	UE Cat eg	Notes
<b>FDD</b>									
FDD	Table A.3.16.1-1	R.sTTI.1 FDD	10	16QAM	1/2	50		≥2	Slot-PDSCH
FDD	Table A.3.16.1-2	R.sTTI.2 FDD	10	16QAM	0.45	50		≥2	Subslot-PDSCH
FDD	Table A.3.16.1-3	R.sTTI.3 FDD	10	QPSK	1/3	50		≥2	Slot-PDSCH
FDD	Table A.3.16.1-4	R.sTTI.4 FDD	10	QPSK	1/3	50		≥2	Subslot-PDSCH
<b>TDD</b>									
TDD	Table A.3.16.2-1	R.sTTI.1 TDD	10	16QAM	1/2	50		≥2	Slot-PDSCH
TDD	Table A.3.16.2-1	R.sTTI.2 TDD	10	QPSK	1/3	50		≥2	Slot-PDSCH

**Table A.3.1.1-1X: Overview of DL reference measurement channels (SPDCCH)**

Duplex	Table	Name	BW	Mod	TCR	RB	RB Off set	UE Cat eg	Notes
<b>FDD</b>									
FDD	Table A.3.17.1-1	R.sTTI.10 FDD	10	SPDCCH					
FDD	Table A.3.17.1-1	R.sTTI.11 FDD	10	SPDCCH					
<b>TDD</b>									
TDD	Table A.3.17.2-1	R.sTTI.10 TDD	10	SPDCCH					
TDD	Table A.3.17.2-1	R.sTTI.11 TDD	10	SPDCCH					

## A.3.2 Reference measurement channel for receiver characteristics

Unless otherwise stated, Tables A.3.2-1, A.3.2-1a, A.3.2-1b, A.3.2-2, A.3.2-2a and A.3.2-2b are applicable for measurements on the Receiver Characteristics (clause 7) with the exception of subclause 7.4 (Maximum input level).

Unless otherwise stated, Tables A.3.2-3, A.3.2-3a, A.3.2-3b, A.3.2-4, A.3.2-4a and A.3.2-4b are applicable for subclause 7.4 (Maximum input level).

Unless otherwise stated, Tables A.3.2-1, A.3.2-1a, A.3.2-1b, A.3.2-2, A.3.2-2a and A.3.2-2b also apply for the modulated interferer used in Clauses 7.5, 7.6 and 7.8 with test specific bandwidths.

For transmissions in TDD Band 46, Table A.3.2-2c is applicable for measurements of Receiver Characteristics (clause 7) except for the Maximum Input Level (clause 7.4A) for which Table A.3.2-4d and Table A.3.2-7 apply. For these measurements, the discovery signals measurement timing configuration (DMTC) periodicity shall be set at *dmTC-Periodicity* = 40 ms with an offset *dmTC-Offset* = 0 for the channel and the DRS shall be transmitted in the first subframe of each DMTC occasion. Furthermore, no PBCH is transmitted and the PDSCH is also scheduled in subframe #5.

Table A.3.2-1 Fixed Reference Channel for Receiver Requirements (FDD)

Parameter	Unit	Value					
		1.4	3	5	10	15	20
Channel bandwidth	MHz	1.4	3	5	10	15	20
Allocated resource blocks		6	15	25	50	75	100
Subcarriers per resource block		12	12	12	12	12	12
Allocated subframes per Radio Frame		9	9	9	9	9	9
Modulation		QPSK	QPSK	QPSK	QPSK	QPSK	QPSK
Target Coding Rate		1/3	1/3	1/3	1/3	1/3	1/3
Number of HARQ Processes	Processes	8	8	8	8	8	8
Maximum number of HARQ transmissions		1	1	1	1	1	1
Information Bit Payload per Sub-Frame							
For Sub-Frames 1,2,3,4,6,7,8,9	Bits	408	1320	2216	4392	6712	8760
For Sub-Frame 5	Bits	N/A	N/A	N/A	N/A	N/A	N/A
For Sub-Frame 0	Bits	152	872	1800	4392	6712	8760
Transport block CRC	Bits	24	24	24	24	24	24
Number of Code Blocks per Sub-Frame (Note 3)							
For Sub-Frames 1,2,3,4,6,7,8,9	Bits	1	1	1	1	2	2
For Sub-Frame 5	Bits	N/A	N/A	N/A	N/A	N/A	N/A
For Sub-Frame 0	Bits	1	1	1	1	2	2
Binary Channel Bits Per Sub-Frame							
For Sub-Frames 1,2,3,4,6,7,8,9	Bits	1368	3780	6300	13800	20700	27600
For Sub-Frame 5	Bits	N/A	N/A	N/A	N/A	N/A	N/A
For Sub-Frame 0	Bits	528	2940	5460	12960	19860	26760
Max. Throughput averaged over 1 frame	kbps	341.6	1143.	1952.	3952.	6040.	7884
UE Category		≥ 1	≥ 1	≥ 1	≥ 1	≥ 1	≥ 1
Note 1:	2 symbols allocated to PDCCH for 20 MHz, 15 MHz and 10MHz channel BW. 3 symbols allocated to PDCCH for 5 MHz and 3 MHz. 4 symbols allocated to PDCCH for 1.4 MHz						
Note 2:	Reference signal, Synchronization signals and PBCH allocated as per TS 36.211 [4]						
Note 3:	If more than one Code Block is present, an additional CRC sequence of L = 24 Bits is attached to each Code Block (otherwise L = 0 Bit)						

Table A.3.2-1a Fixed Reference Channel for Receiver Requirements (FDD)

Parameter	Unit	Value					
		1.4	3	5	10	15	20
Channel bandwidth	MHz	1.4	3	5	10	15	20
Allocated resource blocks		6	14	14	14	14	14
Subcarriers per resource block		12	12	12	12	12	12
Allocated subframes per Radio Frame		9	9	9	9	9	9
Modulation		QPSK	QPSK	QPSK	QPSK	QPSK	QPSK
Target Coding Rate		1/3	1/3	1/3	1/3	1/3	1/3
Number of HARQ Processes	Processes	8	8	8	8	8	8
Maximum number of HARQ transmissions		1	1	1	1	1	1
Information Bit Payload per Sub-Frame							
For Sub-Frames 1,2,3,4,6,7,8,9	Bits	408	1000	1000	1000	1000	1000
For Sub-Frame 5	Bits	N/A	N/A	N/A	N/A	N/A	N/A
For Sub-Frame 0 (Note 3)	Bits	152	840	840	904	904	904
Transport block CRC	Bits	24	24	24	24	24	24
Number of Code Blocks per Sub-Frame							
For Sub-Frames 1,2,3,4,6,7,8,9	Bits	1	1	1	1	1	1
For Sub-Frame 5	Bits	N/A	N/A	N/A	N/A	N/A	N/A
For Sub-Frame 0	Bits	1	1	1	1	1	1
Binary Channel Bits Per Sub-Frame							
For Sub-Frames 1,2,3,4,6,7,8,9	Bits	1368	3528	3528	3864	3864	3864
For Sub-Frame 5	Bits	N/A	N/A	N/A	N/A	N/A	N/A
For Sub-Frame 0 (Note 3)	Bits	528	2688	2688	3024	3024	3024
Max. Throughput averaged over 1 frame	kbps	341.6	884	884	890.4	890.4	890.4
UE DL Category		0	0	0	0	0	0
Note 1:	2 symbols allocated to PDCCH for 20 MHz, 15 MHz and 10MHz channel BW. 3 symbols allocated to PDCCH for 5 MHz and 3 MHz. 4 symbols allocated to PDCCH for 1.4 MHz						
Note 2:	Reference signal, Synchronization signals and PBCH allocated as per TS 36.211.						
Note 3:	For Sub-Frame 0, it is assumed the 6PRBs are allocated in the centre of the channel where some REs of the same PRBs are occupied by PBCH and synchronization signals.						
Note 4:	For HD-FDD UE, the downlink subframes are scheduled at the 0th, 1st, 2nd, 8th, 9th, 10th, 16th, 17th, 18th, 24th, 25th, 26th, 32nd, 33rd, 34th subframes every 40ms. Information bit payload is available if downlink subframe is scheduled.						

Table A.3.2-1b Fixed Reference Channel for Receiver Requirements (FDD and HD-FDD) – for CAT-M1

Parameter	Unit	Value					
		1.4	3	5	10	15	20
Channel bandwidth	MHz	1.4	3	5	10	15	20
Allocated resource blocks		4	4	4	4	4	4
Subcarriers per resource block		12	12	12	12	12	12
Allocated subframes per Radio Frame (Note 6)		2	2	8	8	8	8
Modulation		QPSK	QPSK	QPSK	QPSK	QPSK	QPSK
Target Coding Rate		1/3	1/3	1/3	1/3	1/3	1/3
Number of HARQ Processes	Processes	8	8	8	8	8	8
Maximum number of HARQ transmissions		1	1	1	1	1	1
Information Bit Payload per Sub-Frame							
For Sub-Frames 3,8	Bits	256	256	256	328	328	328
For Sub-Frames 0,1,2,5,7,9	Bits	N/A	N/A	256	328	328	328
For Sub-Frame 4	Bits	N/A	N/A	N/A	N/A	N/A	N/A
For Sub-Frame 6	Bits	N/A	N/A	N/A	N/A	N/A	N/A
Transport block CRC	Bits	24	24	24	24	24	24
Number of Code Blocks per Sub-Frame							
For Sub-Frames 3,8	Bits	1	1	1	1	1	1
For Sub-Frames 0,1,2,5,7,9	Bits	N/A	N/A	1	1	1	1
For Sub-Frame 4	Bits	N/A	N/A	N/A	N/A	N/A	N/A
For Sub-Frame 6	Bits	N/A	N/A	N/A	N/A	N/A	N/A
Binary Channel Bits Per Sub-Frame							
For Sub-Frames 3,8	Bits	912	1008	1008	1104	1104	1104
For Sub-Frames 0,1,2,5,7,9	Bits	N/A	N/A	1008	1104	1104	1104
For Sub-Frame 4	Bits	N/A	N/A	N/A	N/A	N/A	N/A
For Sub-Frame 6	Bits	N/A	N/A	N/A	N/A	N/A	N/A
Max. Throughput averaged over 1 frame for FDD	kbps	51.2	51.2	204.8	262.4	262.4	262.4
Max. Throughput averaged over 1 frames for HD-FDD	kbps	25.6	25.6	76.8	98.4	98.4	98.4
UE DL Category		M1	M1	M1	M1	M1	M1
Note 1:	2 symbols allocated to PDCCH for 20 MHz, 15 MHz and 10MHz channel BW. 3 symbols allocated to PDCCH for 5 MHz and 3 MHz. 4 symbols allocated to PDCCH for 1.4 MHz						
Note 2:	Reference signal, Synchronization signals and PBCH allocated as per TS 36.211.						
Note 3:	The scheduled narrowband other than 1.4MHz and 3MHz channel bandwidth avoids the centre of the channel where some REs of the same PRBs are occupied by PBCH and synchronization signals.						
Note 4:	For HD-FDD UE, PDSCH are scheduled at the 3rd subframe every 1 radio frame for 1.4MHz and 3MHz channel bandwidth. For other channel bandwidth, PDSCH are scheduled at the 0th, 1st and 2nd subframes every 1 radio frame. Information bit payload is available if downlink subframe is scheduled. The corresponding M-PDCCH is scheduled 2 subframes before the corresponding PDSCH transmission.						
Note 5:	2 resource blocks allocated to M-PDCCH						

**Table A.3.2-1c Fixed Reference Channel for Receiver Requirements (HD-FDD) without repetition – for CAT-NB1**

Parameter		Unit	Value
Channel bandwidth	MHz	0.2	
Number of subcarriers		12	
Modulation		QPSK	
Target Coding Rate		1/3	
Number of HARQ Processes	Processes	1	
Maximum number of HARQ transmissions		1	
Transport block size	Bits	88	
Number of Sub-Frames per transport block		1	
Transport block CRC	Bits	24	
Binary Channel Bits Per Sub-Frame	Bits	320	
LTE CRS port		N/A	
Number of NRS ports		1	
Number of NPDSCH repetitions		0	
UE DL Category		NB1	

Note 1: Category NB1 in stand-alone mode has been considered here.

Note 2: Reference signal, Synchronization signals and NPBCH allocated as per TS 36.211.

Note 3: If more than one Code Block is present, an additional CRC sequence of L = 24 Bits is attached to each Code Block (otherwise L = 0 Bit)

Note 4: Parameters related to NPDSCH scheduling are defined in Table A.3.2-1e to Table A.3.2-1g.

Note 5: NPDCCH and information bit payload are not transmitted in the subframes used for transmission of SI messages.

Note 6: SI messages transmission should be prioritized over NPDCCH transmission in case of collision. NPDCCH transmission is postponed until the next NB-IoT downlink subframe in case NPDCCH transmission occurs in a non NB-IoT downlink subframe, where an NB-IoT downlink subframe is a subframe that does not contain NPSS/NSSS/NPBCH/SIB1-NB transmission.

**Table A.3.2-1d: Void****Table A.3.2-1e: General configuration for CAT-NB1**

Parameter	Unit	Value
NB-IoT downlink subframe bitmap for anchor carrier ( <i>downlinkBitmap</i> )		Not configured
NB-IoT downlink subframe bitmap for non-anchor carrier ( <i>downlinkBitmapNonAnchor</i> )		Not configured
Downlink gap configuration for anchor carrier ( <i>dl-Gap</i> )		Not configured
Downlink gap configuration for non-anchor carrier ( <i>dl-GapNonAnchor</i> )		Not configured



**Table A.3.2-1f: NPDCCH configuration for NPDSCH scheduling**

Parameter	Unit	Value
DCI format		DCI format N1
NPDCCH format		1
Scheduling delay ( $I_{\text{Delay}}$ )		0
DCI subframe repetition number		00
$R_{\text{max}}$ ( <i>npdcch-NumRepetitions</i> )		1
G ( <i>NPDCCH-startSF-USS</i> )		8
$\alpha_{\text{offset}}$ ( <i>npdcch-Offset-USS</i> )		1/4

**Table A.3.2-1g: NPUSCH format 2 configurations for NPDSCH scheduling**

Parameter	Unit	Value
Scheduling delay ( $I_{\text{Delay}}$ )		0
$N_{\text{Rep}}^{\text{AN}}$ ( <i>ack-NACK-NumRepetitions</i> )		1
ACK/NACK resource field		0

Table A.3.2-1h: Fixed Reference Channel for Receiver Requirements (FDD and HD-FDD) – for CAT-M2

Parameter	Unit	Value					
		1.4	3	5	10	15	20
Channel bandwidth	MHz	1.4	3	5	10	15	20
Allocated resource blocks (Note 6)		4	8	16	16	16	16
Subcarriers per resource block		12	12	12	12	12	12
Allocated subframes per Radio Frame (Note 4)		2	2	8	8	8	8
Modulation		QPSK	QPSK	QPSK	QPSK	QPSK	QPSK
Target Coding Rate		1/3	1/3	1/3	1/3	1/3	1/3
Number of HARQ Processes	Processes	8	8	8	8	8	8
Maximum number of HARQ transmissions		1	1	1	1	1	1
Information Bit Payload per Sub-Frame							
For Sub-Frames 3,8	Bits	256	680	1384	1384	1384	1384
For Sub-Frames 0,1,2,5,7,9	Bits	N/A	N/A	N/A	N/A	1384	1384
For Sub-Frame 4	Bits	N/A	N/A	N/A	N/A	N/A	N/A
For Sub-Frame 6	Bits	N/A	N/A	N/A	N/A	N/A	N/A
Transport block CRC	Bits	24	24	24	24	24	24
Number of Code Blocks per Sub-Frame							
For Sub-Frames 3,8	Bits	1	1	1	1	1	1
For Sub-Frames 0,1,2,5,7,9	Bits	N/A	N/A	1	1	1	1
For Sub-Frame 4	Bits	N/A	N/A	N/A	N/A	N/A	N/A
For Sub-Frame 6	Bits	N/A	N/A	N/A	N/A	N/A	N/A
Binary Channel Bits Per Sub-Frame							
For Sub-Frames 3,8	Bits	912	2016	4032	4416	4416	4416
For Sub-Frames 0,1,2,5,7,9	Bits	N/A	N/A	N/A	N/A	4416	4416
For Sub-Frame 4	Bits	N/A	N/A	N/A	N/A	N/A	N/A
For Sub-Frame 6	Bits	N/A	N/A	N/A	N/A	N/A	N/A
Max. Throughput averaged over 1 frame for FDD	kbps	51.2	136.0	276.8	276.8	1107.2	1107.2
Max. Throughput averaged over 1 frames for HD-FDD	kbps	25.6	68.0	138.4	138.4	415.2	415.2
UE DL Category		M2	M2	M2	M2	M2	M2
Note 1:	2 symbols allocated to PDCCH for 20 MHz, 15 MHz and 10MHz channel BW. 3 symbols allocated to PDCCH for 5 MHz and 3 MHz. 4 symbols allocated to PDCCH for 1.4 MHz						
Note 2:	Reference signal, Synchronization signals and PBCH allocated as per TS 36.211.						
Note 3:	The scheduled wideband other than 1.4MHz/3MHz/5MHz/15MHz channel bandwidth avoids the centre of the channel where some REs of the same PRBs are occupied by PBCH and synchronization signals.						
Note 4:	For HD-FDD UE, PDSCH are scheduled at the 3rd subframe every 1 radio frame for 1.4MHz/3MHz/5MHz/10MHz channel bandwidth. For other channel bandwidth, PDSCH are scheduled at the 0th, 1st and 2nd subframes every 1 radio frame. Information bit payload is available if downlink subframe is scheduled. The corresponding MPDCCH is scheduled 2 subframes before the corresponding PDSCH transmission.						
Note 5:	2 resource blocks allocated to MPDCCH.						
Note 6:	4 resource blocks in each narrowband allocated to PDSCH.						

Table A.3.2-2 Fixed Reference Channel for Receiver Requirements (TDD)

Parameter	Unit	Value					
Channel Bandwidth	MHz	1.4	3	5	10	15	20
Allocated resource blocks		6	15	25	50	75	100
Uplink-Downlink Configuration (Note 5)		1	1	1	1	1	1
Allocated subframes per Radio Frame (D+S)		3	3+2	3+2	3+2	3+2	3+2
Number of HARQ Processes	Processes	7	7	7	7	7	7
Maximum number of HARQ transmission		1	1	1	1	1	1
Modulation		QPSK	QPSK	QPSK	QPSK	QPSK	QPSK
Target coding rate		1/3	1/3	1/3	1/3	1/3	1/3
Information Bit Payload per Sub-Frame	Bits						
For Sub-Frame 4, 9		408	1320	2216	4392	6712	8760
For Sub-Frame 1, 6		N/A	968	1544	3240	4968	6712
For Sub-Frame 5		N/A	N/A	N/A	N/A	N/A	N/A
For Sub-Frame 0		208	1064	1800	4392	6712	8760
Transport block CRC	Bits	24	24	24	24	24	24
Number of Code Blocks per Sub-Frame (Note 4)							
For Sub-Frame 4, 9		1	1	1	1	2	2
For Sub-Frame 1, 6		N/A	1	1	1	1	2
For Sub-Frame 5		N/A	N/A	N/A	N/A	N/A	N/A
For Sub-Frame 0		1	1	1	1	2	2
Binary Channel Bits Per Sub-Frame	Bits						
For Sub-Frame 4, 9		1368	3780	6300	13800	20700	27600
For Sub-Frame 1, 6		N/A	3276	5556	11256	16956	22656
For Sub-Frame 5		N/A	N/A	N/A	N/A	N/A	N/A
For Sub-Frame 0		672	3084	5604	13104	20004	26904
Max. Throughput averaged over 1 frame	kbps	102.4	564	932	1965.6	3007.2	3970.4
UE Category		≥ 1	≥ 1	≥ 1	≥ 1	≥ 1	≥ 1
Note 1:	For normal subframes(0,4,5,9), 2 symbols allocated to PDCCH for 20 MHz, 15 MHz and 10 MHz channel BW; 3 symbols allocated to PDCCH for 5 MHz and 3 MHz; 4 symbols allocated to PDCCH for 1.4 MHz. For special subframe (1&6), only 2 OFDM symbols are allocated to PDCCH for all BWs.						
Note 2:	For 1.4MHz, no data shall be scheduled on special subframes(1&6) to avoid problems with insufficient PDCCH performance						
Note 3:	Reference signal, Synchronization signals and PBCH allocated as per TS 36.211 [4]						
Note 4:	If more than one Code Block is present, an additional CRC sequence of L = 24 Bits is attached to each Code Block (otherwise L = 0 Bit).						
Note 5:	As per Table 4.2-2 in TS 36.211 [4]						

Table A.3.2-2a Fixed Reference Channel for Receiver Requirements (TDD)

Parameter	Unit	Value					
		1.4	3	5	10	15	20
Channel Bandwidth	MHz	1.4	3	5	10	15	20
Allocated resource blocks		6	14	14	14	14	14
Uplink-Downlink Configuration (Note 5)		1	1	1	1	1	1
Allocated subframes per Radio Frame (D+S)		3	3+2	3+2	3+2	3+2	3+2
Number of HARQ Processes	Processes	7	7	7	7	7	7
Maximum number of HARQ transmission		1	1	1	1	1	1
Modulation		QPSK	QPSK	QPSK	QPSK	QPSK	QPSK
Target coding rate		1/3	1/3	1/3	1/3	1/3	1/3
Information Bit Payload per Sub-Frame	Bits						
For Sub-Frame 4, 9		408	1000	1000	1000	1000	1000
For Sub-Frame 1, 6		N/A	872	872	872	872	872
For Sub-Frame 5		N/A	N/A	N/A	N/A	N/A	N/A
For Sub-Frame 0		208	1000	1000	1000	1000	1000
Transport block CRC	Bits	24	24	24	24	24	24
Number of Code Blocks per Sub-Frame (Note 4)							
For Sub-Frame 4, 9		1	1	1	1	1	1
For Sub-Frame 1, 6		N/A	1	1	1	1	1
For Sub-Frame 5		N/A	N/A	N/A	N/A	N/A	N/A
For Sub-Frame 0		1	1	1	1	1	1
Binary Channel Bits Per Sub-Frame	Bits						
For Sub-Frame 4, 9		1368	3528	3528	3864	3864	3864
For Sub-Frame 1, 6		N/A	3048	3048	3048	3048	3048
For Sub-Frame 5		N/A	N/A	N/A	N/A	N/A	N/A
For Sub-Frame 0		672	2832	2832	3168	3168	3168
Max. Throughput averaged over 1 frame	kbps	102.4	474.4	474.4	474.4	474.4	474.4
UE DL Category		0	0	0	0	0	0
Note 1:	For normal subframes(0,4,5,9), 2 symbols allocated to PDCCH for 20 MHz, 15 MHz and 10 MHz channel BW; 3 symbols allocated to PDCCH for 5 MHz and 3 MHz; 4 symbols allocated to PDCCH for 1.4 MHz. For special subframe (1&6), only 2 OFDM symbols are allocated to PDCCH for all BWs.						
Note 2:	For 1.4MHz, no data shall be scheduled on special subframes(1&6) to avoid problems with insufficient PDCCH performance						
Note 3:	Reference signal, Synchronization signals and PBCH allocated as per TS 36.211 [4]						
Note 4:	If more than one Code Block is present, an additional CRC sequence of L = 24 Bits is attached to each Code Block (otherwise L = 0 Bit).						
Note 5:	As per Table 4.2-2 in TS 36.211 [4]						

Table A.3.2-2b Fixed Reference Channel for Receiver Requirements (TDD) – for CAT-M1

Parameter	Unit	Value					
		1.4	3	5	10	15	20
Channel Bandwidth	MHz	1.4	3	5	10	15	20
Allocated resource blocks		4	4	4	4	4	4
Uplink-Downlink Configuration (Note 5)		1	1	1	1	1	1
Allocated subframes per Radio Frame (D)		3	3	3	3	3	3
Number of HARQ Processes	Processes	7	7	7	7	7	7
Maximum number of HARQ transmission		1	1	1	1	1	1
Modulation		QPSK	QPSK	QPSK	QPSK	QPSK	QPSK
Target coding rate		1/3	1/3	1/3	1/3	1/3	1/3
Information Bit Payload per Sub-Frame	Bits						
For Sub-Frame 4, 9		256	256	256	328	328	328
For Sub-Frame 1, 6		N/A	N/A	N/A	N/A	N/A	N/A
For Sub-Frame 5		N/A	N/A	N/A	N/A	N/A	N/A
For Sub-Frame 0		256	256	256	328	328	328
Transport block CRC	Bits	24	24	24	24	24	24
Number of Code Blocks per Sub-Frame (Note 4)							
For Sub-Frame 4, 9		1	1	1	1	1	1
For Sub-Frame 1, 6		N/A	1	1	1	1	1
For Sub-Frame 5		N/A	N/A	N/A	N/A	N/A	N/A
For Sub-Frame 0		1	1	1	1	1	1
Binary Channel Bits Per Sub-Frame	Bits						
For Sub-Frame 4, 9		912	1008	1008	1104	1104	1104
For Sub-Frame 1, 6		N/A	N/A	N/A	N/A	N/A	N/A
For Sub-Frame 5		N/A	N/A	N/A	N/A	N/A	N/A
For Sub-Frame 0		912	1008	1008	1104	1104	1104
Max. Throughput averaged over 1 frame	kbps	76.8	76.8	76.8	98.4	98.4	98.4
UE DL Category		M1	M1	M1	M1	M1	M1
Note 1:	For normal subframes(0,4,5,9), 2 symbols allocated to PDCCH for 20 MHz, 15 MHz and 10 MHz channel BW; 3 symbols allocated to PDCCH for 5 MHz and 3 MHz; 4 symbols allocated to PDCCH for 1.4 MHz. For special subframe (1&6), only 2 OFDM symbols are allocated to PDCCH for all BWs.						
Note 2:	No data shall be scheduled on special subframes(1&6) to avoid problems with insufficient PDCCH performance						
Note 3:	Reference signal, Synchronization signals and PBCH allocated as per TS 36.211 [4]						
Note 4:	If more than one Code Block is present, an additional CRC sequence of L = 24 Bits is attached to each Code Block (otherwise L = 0 Bit).						
Note 5:	As per Table 4.2-2 in TS 36.211 [4]						
Note 6:	For Sub-Frame 0, the scheduled narrowband avoids the centre of the channel where some REs of the same PRBs are occupied by PBCH and synchronization signals.						
Note 7:	2 resource blocks allocated to MPDCCH						

Table A.3.2-2c Fixed Reference Channel for Receiver Requirements (TDD Band 46)

Parameter	Unit	Value
Channel bandwidth	MHz	20
Allocated resource blocks		100
Uplink-Downlink Configuration		N/A
Subcarriers per resource block		12
Allocated subframes per Radio Frame (D)		8
Modulation		QPSK
Target Coding Rate		1/3
Number of HARQ Processes	Processes	N/A
Maximum number of HARQ transmissions		N/A
Information Bit Payload per Sub-Frame		
For Sub-Frames 3,4,6,7,8,9	Bits	8760
For Sub-Frame 1,2	Bits	N/A
For Sub-Frame 0,5	Bits	8760
Transport block CRC	Bits	24
Number of Code Blocks per Sub-Frame (Note 3)		
For Sub-Frames 3,4,6,7,8,9	Bits	2
For Sub-Frame 1,2	Bits	N/A
For Sub-Frame 0,5	Bits	2
Binary Channel Bits Per Sub-Frame		
For Sub-Frames 3,4,6,7,8,9	Bits	27600
For Sub-Frame 1,2	Bits	N/A
For Sub-Frame 0,5	Bits	27312
Max. Throughput averaged over 1 frame	kbps	7008
UE Category		$\geq 1$
Note 1:	2 symbols allocated to PDCCH.	
Note 2:	Reference signal and Synchronization signals allocated as per TS 36.211 [4].	
Note 3:	If more than one Code Block is present, an additional CRC sequence of L = 24 Bits is attached to each Code Block (otherwise L = 0 Bit).	

Table A.3.2-2d: Fixed Reference Channel for Receiver Requirements (TDD) – for CAT-M2

Parameter	Unit	Value					
		1.4	3	5	10	15	20
Channel Bandwidth	MHz	1.4	3	5	10	15	20
Allocated resource blocks (Note 8)		4	8	16	16	16	16
Uplink-Downlink Configuration (Note 5)		1	1	1	1	1	1
Allocated subframes per Radio Frame (D)		3	3	3	3	3	3
Number of HARQ Processes	Processes	7	7	7	7	7	7
Maximum number of HARQ transmission		1	1	1	1	1	1
Modulation		QPSK	QPSK	QPSK	QPSK	QPSK	QPSK
Target coding rate		1/3	1/3	1/3	1/3	1/3	1/3
Information Bit Payload per Sub-Frame	Bits						
For Sub-Frame 4, 9		256	680	1384	1384	1384	1384
For Sub-Frame 1, 6		N/A	N/A	N/A	N/A	N/A	N/A
For Sub-Frame 5		N/A	N/A	N/A	N/A	N/A	N/A
For Sub-Frame 0		256	680	1384	1384	1384	1384
Transport block CRC	Bits	24	24	24	24	24	24
Number of Code Blocks per Sub-Frame (Note 4)							
For Sub-Frame 4, 9		1	1	1	1	1	1
For Sub-Frame 1, 6		N/A	N/A	N/A	N/A	N/A	N/A
For Sub-Frame 5		N/A	N/A	N/A	N/A	N/A	N/A
For Sub-Frame 0		1	1	1	1	1	1
Binary Channel Bits Per Sub-Frame	Bits						
For Sub-Frame 4, 9		912	2016	4032	4416	4416	4416
For Sub-Frame 1, 6		N/A	N/A	N/A	N/A	N/A	N/A
For Sub-Frame 5		N/A	N/A	N/A	N/A	N/A	N/A
For Sub-Frame 0		912	2016	4032	4416	4416	4416
Max. Throughput averaged over 1 frame	kbps	76.8	204.0	415.2	415.2	415.2	415.2
UE DL Category		M2	M2	M2	M2	M2	M2
Note 1:	For normal subframes(0,4,5,9), 2 symbols allocated to PDCCH for 20 MHz, 15 MHz and 10 MHz channel BW; 3 symbols allocated to PDCCH for 5 MHz and 3 MHz; 4 symbols allocated to PDCCH for 1.4 MHz. For special subframe (1&6), only 2 OFDM symbols are allocated to PDCCH for all BWs.						
Note 2:	No data shall be scheduled on special subframes(1&6) to avoid problems with insufficient PDCCH performance						
Note 3:	Reference signal, Synchronization signals and PBCH allocated as per TS 36.211 [4]						
Note 4:	If more than one Code Block is present, an additional CRC sequence of L = 24 Bits is attached to each Code Block (otherwise L = 0 Bit).						
Note 5:	As per Table 4.2-2 in TS 36.211 [4]						
Note 6:	For Sub-Frame 0, the scheduled narrowband avoids the centre of the channel where some REs of the same PRBs are occupied by PBCH and synchronization signals.						
Note 7:	2 resource blocks allocated to MPDCCH						
Note 8:	4 resource blocks in each narrowband allocated to PDSCH.						

**Table A.3.2-2e Fixed Reference Channel for Receiver Requirements (TDD) – for CAT-NB1 and CAT-NB2**

	Parameter		Unit	Value
Channel bandwidth	MHz	0.2		
Number of subcarriers		12		
Uplink-Downlink Configuration (Note 7)		1		
Modulation		QPSK		
Target Coding Rate		1/3		
Number of HARQ Processes	Processes	1		
Maximum number of HARQ transmissions		1		
Transport block size	Bits	88		
Number of Sub-Frames per transport block		1		
Transport block CRC	Bits	24		
Binary Channel Bits Per Sub-Frame	Bits	320		
LTE CRS port		N/A		
Number of NRS ports		1		
Number of NPDSCH repetitions		0		
UE DL Category		NB1 or NB2		

Note 1:	Category NB1 or NB2 in stand-alone mode has been considered here.
Note 2:	Reference signal, Synchronization signals and NPBCH allocated as per TS 36.211.
Note 3:	If more than one Code Block is present, an additional CRC sequence of L = 24 Bits is attached to each Code Block (otherwise L = 0 Bit)
Note 4:	Parameters related to NPDSCH scheduling are defined in Table A.3.2-1e to Table A.3.2-1g.
Note 5:	NPDCCH and information bit payload are not transmitted in the subframes used for transmission of SI messages.
Note 6:	SI messages transmission should be prioritized over NPDCCH transmission in case of collision. NPDCCH transmission is postponed until the next NB-IoT downlink subframe in case NPDCCH transmission occurs in a non NB-IoT downlink subframe, where an NB-IoT downlink subframe is a subframe that does not contain NPSS/NSSS/NPBCH/SIB1-NB transmission.
Note 7:	As per Table 4.2-2 in TS 36.211 [4]



Table A.3.2-3 Fixed Reference Channel for Maximum input level for UE Categories  $\geq 3$ (FDD)

Parameter	Unit	Value					
Channel bandwidth	MHz	1.4	3	5	10	15	20
Allocated resource blocks		6	15	25	50	75	100
Subcarriers per resource block		12	12	12	12	12	12
Allocated subframes per Radio Frame		8	9	9	9	9	9
Modulation		64QAM	64QAM	64QAM	64QAM	64QAM	64QAM
Target Coding Rate		3/4	3/4	3/4	3/4	3/4	3/4
Number of HARQ Processes	Processes	8	8	8	8	8	8
Maximum number of HARQ transmissions		1	1	1	1	1	1
Information Bit Payload per Sub-Frame							
For Sub-Frames 1,2,3,4,6,7,8,9	Bits	2984	8504	14112	30576	46888	61664
For Sub-Frame 5	Bits	N/A	N/A	N/A	N/A	N/A	N/A
For Sub-Frame 0	Bits	N/A	6456	12576	28336	45352	61664
Transport block CRC	Bits	24	24	24	24	24	24
Number of Code Blocks per Sub-Frame (Note 3)							
For Sub-Frames 1,2,3,4,6,7,8,9		1	2	3	5	8	11
For Sub-Frame 5		N/A	N/A	N/A	N/A	N/A	N/A
For Sub-Frame 0		N/A	2	3	5	8	11
Binary Channel Bits Per Sub-Frame							
For Sub-Frames 1,2,3,4,6,7,8,9	Bits	4104	11340	18900	41400	62100	82800
For Sub-Frame 5	Bits	N/A	N/A	N/A	N/A	N/A	N/A
For Sub-Frame 0	Bits	N/A	8820	16380	38880	59580	80280
Max. Throughput averaged over 1 frame	kbps	2387.2	7448.8	12547	27294	42046	55498
Note 1: 2 symbols allocated to PDCCH for 20 MHz, 15 MHz and 10 MHz channel BW. 3 symbols allocated to PDCCH for 5 MHz and 3 MHz. 4 symbols allocated to PDCCH for 1.4 MHz.							
Note 2: Reference signal, Synchronization signals and PBCH allocated as per TS 36.211 [4].							
Note 3: If more than one Code Block is present, an additional CRC sequence of L = 24 Bits is attached to each Code Block (otherwise L = 0 Bit).							

Table A.3.2-3a Fixed Reference Channel for Maximum input level for UE Category 1 (FDD)

Parameter	Unit	Value					
Channel bandwidth	MHz	1.4	3	5	10	15	20
Allocated resource blocks		6	15	18	17	17	17
Subcarriers per resource block		12	12	12	12	12	12
Allocated subframes per Radio Frame		8	9	9	9	9	9
Modulation		64QAM	64QAM	64QAM	64QAM	64QAM	64QAM
Target Coding Rate		3/4	3/4	3/4	3/4	3/4	3/4
Number of HARQ Processes	Processes	8	8	8	8	8	8
Maximum number of HARQ transmissions		1	1	1	1	1	1
Information Bit Payload							
For Sub-Frames 1,2,3,4,6,7,8,9	Bits	2984	8504	10296	10296	10296	10296
For Sub-Frame 5	Bits	N/A	N/A	N/A	N/A	N/A	N/A
For Sub-Frame 0	Bits	N/A	6456	8248	10296	10296	10296
Transport block CRC	Bits	24	24	24	24	24	24
Number of Code Blocks per Sub-Frame (Note 3)							
For Sub-Frames 1,2,3,4,6,7,8,9		1	2	2	2	2	2
For Sub-Frame 5		N/A	N/A	N/A	N/A	N/A	N/A
For Sub-Frame 0		N/A	2	2	2	2	2
Binary Channel Bits Per Sub-Frame							
For Sub-Frames 1,2,3,4,6,7,8,9	Bits	4104	11340	13608	14076	14076	14076
For Sub-Frame 5	Bits	N/A	N/A	N/A	N/A	N/A	N/A
For Sub-Frame 0	Bits	N/A	8820	11088	14076	14076	14076
Max. Throughput averaged over 1 frame	kbps	2387.2	7448.8	9079.6	9266.4	9266.4	9266.4
Note 1: 2 symbols allocated to PDCCH for 20 MHz, 15 MHz and 10 MHz channel BW. 3 symbols allocated to PDCCH for 5 MHz and 3 MHz. 4 symbols allocated to PDCCH for 1.4 MHz.							
Note 2: Reference signal, Synchronization signals and PBCH allocated as per TS 36.211 [4].							
Note 3: If more than one Code Block is present, an additional CRC sequence of L = 24 Bits is attached to each Code Block (otherwise L = 0 Bit).							

Table A.3.2-3b Fixed Reference Channel for Maximum input level for UE Category 2 (FDD)

Parameter	Unit	Value					
		1.4	3	5	10	15	20
Channel bandwidth	MHz	1.4	3	5	10	15	20
Allocated resource blocks		6	15	25	50	75	83
Subcarriers per resource block		12	12	12	12	12	12
Allocated subframes per Radio Frame		8	9	9	9	9	9
Modulation		64QAM	64QAM	64QAM	64QAM	64QAM	64QAM
Target Coding Rate		3/4	3/4	3/4	3/4	3/4	3/4
Number of HARQ Processes	Processes	8	8	8	8	8	8
Maximum number of HARQ transmissions		1	1	1	1	1	1
Information Bit Payload							
For Sub-Frames 1,2,3,4,6,7,8,9	Bits	2984	8504	14112	30576	46888	51024
For Sub-Frame 5	Bits	N/A	N/A	N/A	N/A	N/A	N/A
For Sub-Frame 0	Bits	N/A	6456	12576	28336	45352	51024
Transport block CRC	Bits	24	24	24	24	24	24
Number of Code Blocks per Sub-Frame (Note 3)							
For Sub-Frames 1,2,3,4,6,7,8,9		1	2	3	5	8	9
For Sub-Frame 5		N/A	N/A	N/A	N/A	N/A	N/A
For Sub-Frame 0		N/A	2	3	5	8	9
Binary Channel Bits Per Sub-Frame							
For Sub-Frames 1,2,3,4,6,7,8,9	Bits	4104	11340	18900	41400	62100	68724
For Sub-Frame 5	Bits	N/A	N/A	N/A	N/A	N/A	N/A
For Sub-Frame 0	Bits	N/A	8820	16380	38880	59580	66204
Max. Throughput averaged over 1 frame	kbps	2387.2	7448.8	12547	27294	42046	45922
Note 1: 2 symbols allocated to PDCCH for 20 MHz, 15 MHz and 10 MHz channel BW. 3 symbols allocated to PDCCH for 5 MHz and 3 MHz. 4 symbols allocated to PDCCH for 1.4 MHz.							
Note 2: Reference signal, Synchronization signals and PBCH allocated as per TS 36.211 [4].							
Note 3: If more than one Code Block is present, an additional CRC sequence of L = 24 Bits is attached to each Code Block (otherwise L = 0 Bit).							

Table A.3.2-3c Fixed Reference Channel for Maximum input level for UE DL Category 0 (FDD)

Parameter	Unit	Value					
		1.4	3	5	10	15	20
Channel bandwidth	MHz	1.4	3	5	10	15	20
Allocated resource blocks		2	2	2	2	2	2
Subcarriers per resource block		12	12	12	12	12	12
Allocated subframes per Radio Frame		8	9	9	9	9	9
Modulation		64QAM	64QAM	64QAM	64QAM	64QAM	64QAM
Target Coding Rate		3/4	3/4	3/4	3/4	3/4	3/4
Number of HARQ Processes	Processes	8	8	8	8	8	8
Maximum number of HARQ transmissions		1	1	1	1	1	1
Information Bit Payload							
For Sub-Frames 1,2,3,4,6,7,8,9	Bits	1000	1000	1000	1000	1000	1000
For Sub-Frame 5	Bits	N/A	N/A	N/A	N/A	N/A	N/A
For Sub-Frame 0 (Note 3)	Bits	N/A	1000	1000	1000	1000	1000
Transport block CRC	Bits	24	24	24	24	24	24
Number of Code Blocks per Sub-Frame							
For Sub-Frames 1,2,3,4,6,7,8,9		1	1	1	1	1	1
For Sub-Frame 5		N/A	N/A	N/A	N/A	N/A	N/A
For Sub-Frame 0		N/A	1	1	1	1	1
Binary Channel Bits Per Sub-Frame							
For Sub-Frames 1,2,3,4,6,7,8,9	Bits	1368	1512	1512	1656	1656	1656
For Sub-Frame 5	Bits	N/A	N/A	N/A	N/A	N/A	N/A
For Sub-Frame 0 (Note 3)	Bits	N/A	1512	1512	1656	1656	1656
Max. Throughput averaged over 1 frame	kbps	800	900	900	900	900	900
Note 1: 2 symbols allocated to PDCCH for 20 MHz, 15 MHz and 10 MHz channel BW. 3 symbols allocated to PDCCH for 5 MHz and 3 MHz. 4 symbols allocated to PDCCH for 1.4 MHz.							
Note 2: Reference signal, Synchronization signals and PBCH allocated as per TS 36.211.							
Note 3: For Sub-Frame 0, it is assumed that the allocated 2PRBs are scheduled on the RBs other than the center 6PRBs as most of the symbols are occupied by PBCH and synchronization signals.							

**Table A.3.2-3d Fixed Reference Channel for Maximum input level for UE DL Category M1 (FDD and HD-FDD)**

Parameter	Unit	Value					
Channel bandwidth	MHz	1.4	3	5	10	15	20
Allocated resource blocks		2	2	2	2	2	2
Subcarriers per resource block		12	12	12	12	12	12
Allocated subframes per Radio Frame (Note 6)		2	2	8	8	8	8
Modulation		16QAM	16QAM	16QAM	16QAM	16QAM	16QAM
Target Coding Rate		3/5	3/5	3/5	3/5	3/5	3/5
Number of HARQ Processes	Processes	8	8	8	8	8	8
Maximum number of HARQ transmissions		1	1	1	1	1	1
Information Bit Payload							
For Sub-Frames 3, 8	Bits	552	552	552	552	552	552
For Sub-Frames 0,1,2,5,7,9	Bits	N/A	N/A	552	552	552	552
For Sub-Frame 4	Bits	N/A	N/A	N/A	N/A	N/A	N/A
For Sub-Frame 6	Bits	N/A	N/A	N/A	N/A	N/A	N/A
Transport block CRC	Bits	24	24	24	24	24	24
Number of Code Blocks per Sub-Frame							
For Sub-Frames 3, 8		1	1	1	1	1	1
For Sub-Frames 0,1,2,5,7,9		N/A	N/A	1	1	1	1
For Sub-Frame 4		N/A	N/A	N/A	N/A	N/A	N/A
For Sub-Frame 6		N/A	N/A	N/A	N/A	N/A	N/A
Binary Channel Bits Per Sub-Frame							
For Sub-Frames 3, 8	Bits	912	1008	1008	1008	1008	1008
For Sub-Frames 0,1,2,5,7,9		N/A	N/A	1008	1008	1008	1008
For Sub-Frame 4	Bits	N/A	N/A	N/A	N/A	N/A	N/A
For Sub-Frame 6	Bits	N/A	N/A	N/A	N/A	N/A	N/A
Max. Throughput averaged over 1 frame for FDD	kbps	110.4	110.4	441.6	441.6	441.6	441.6
Max. Throughput averaged over 1 frame for HD-FDD		55.2	55.2	165.6	165.6	165.6	165.6
Note 1:	4 symbols allocated to PDCCH for 1.4MHz channel bandwidth. 3 symbols allocated to PDCCH for all other channel bandwidths.						
Note 2:	Reference signal, Synchronization signals and PBCH allocated as per TS 36.211.						
Note 3:	The scheduled narrowband other than 1.4MHz and 3MHz channel bandwidth avoids the centre of the channel where some REs of the same PRBs are occupied by PBCH and synchronization signals.						
Note 4:	For HD-FDD UE, PDSCH are scheduled at the 3rd subframe every 1 radio frame for 1.4MHz and 3MHz channel bandwidth. For other channel bandwidth, PDSCH are scheduled at the 0th, 1st, and 2nd subframes every 1 radio frame. Information bit payload is available if downlink subframe is scheduled. The corresponding MPDCCH is scheduled 2 subframes before the corresponding PDSCH transmission.						
Note 5:	2 resource blocks allocated to MPDCCH.						

**Table A.3.2-3e: Fixed Reference Channel for Maximum input level for UE DL Category M2 (FDD and HD-FDD)**

Parameter	Unit	Value					
Channel bandwidth	MHz	1.4	3	5	10	15	20
Allocated resource blocks (Note 6)		2	8	15	15	15	15
Subcarriers per resource block		12	12	12	12	12	12
Allocated subframes per Radio Frame (Note 4)		2	2	8	8	8	8
Modulation		16QAM	16QAM	16QAM	16QAM	16QAM	16QAM
Target Coding Rate		3/5	3/5	1/2	1/2	1/2	1/2
Number of HARQ Processes	Processes	8	8	8	8	8	8
Maximum number of HARQ transmissions		1	1	1	1	1	1
Information Bit Payload							
For Sub-Frames 3, 8	Bits	552	2280	4008	4008	4008	4008
For Sub-Frames 0,1,2,5,7,9	Bits	N/A	N/A	N/A	N/A	4008	4008
For Sub-Frame 4	Bits	N/A	N/A	N/A	N/A	N/A	N/A
For Sub-Frame 6	Bits	N/A	N/A	N/A	N/A	N/A	N/A
Transport block CRC	Bits	24	24	24	24	24	24
Number of Code Blocks per Sub-Frame							
For Sub-Frames 3, 8		1	1	1	1	1	1
For Sub-Frames 0,1,2,5,7,9		N/A	N/A	1	1	1	1
For Sub-Frame 4		N/A	N/A	N/A	N/A	N/A	N/A
For Sub-Frame 6		N/A	N/A	N/A	N/A	N/A	N/A
Binary Channel Bits Per Sub-Frame							
For Sub-Frames 3, 8	Bits	912	4032	7560	7560	7560	7560
For Sub-Frames 0,1,2,5,7,9		N/A	N/A	N/A	N/A	7560	7560
For Sub-Frame 4	Bits	N/A	N/A	N/A	N/A	N/A	N/A
For Sub-Frame 6	Bits	N/A	N/A	N/A	N/A	N/A	N/A
Max. Throughput averaged over 1 frame for FDD	kbps	110.4	456.0	801.6	801.6	3206.4	3206.4
Max. Throughput averaged over 1 frame for HD-FDD		55.2	228.0	400.8	400.8	1202.4	1202.4
Note 1:	4 symbols allocated to PDCCH for 1.4MHz channel bandwidth. 3 symbols allocated to all other channel bandwidths.						
Note 2:	Reference signal, Synchronization signals and PBCH allocated as per TS 36.211.						
Note 3:	The scheduled wideband other than 1.4MHz/3MHz/5MHz/10MHz/ channel bandwidth avoids the centre of the channel where some REs of the same PRBs are occupied by PBCH and synchronization signals.						
Note 4:	For HD-FDD UE, PDSCH are scheduled at the 3rd subframe every 1 radio frame for 1.4MHz/3MHz/5MHz/10MHz channel bandwidth. For other channel bandwidth, PDSCH are scheduled at the 0th, 1st, and 2nd subframes every 1 radio frame. Information bit payload is available if downlink subframe is scheduled. The corresponding MPDCCH is scheduled 2 subframes before the corresponding PDSCH transmission.						
Note 5:	2 resource blocks allocated to MPDCCH.						
Note 6:	2 resource blocks allocated to PDSCH for 1.4MHz channel bandwidth. 2 narrowbands and 4 resource blocks in each narrowband allocated to PDSCH for 3MHz channel bandwidth. For 5MHz/10MHz/15MHz/20MHz channel bandwidth, configure 3 narrowbands and 5 resource blocks in each narrowband allocated to PDSCH.						

Table A.3.2-4 Fixed Reference Channel for Maximum input level for UE Categories  $\geq 3$  (TDD)

Parameter	Unit	Value					
Channel bandwidth	MHz	1.4	3	5	10	15	20
Allocated resource blocks		6	15	25	50	75	100
Subcarriers per resource block		12	12	12	12	12	12
Uplink-Downlink Configuration (Note 5)		1	1	1	1	1	1
Allocated subframes per Radio Frame		2	3+2	3+2	3+2	3+2	3+2
Modulation		64QAM	64QAM	64QAM	64QAM	64QAM	64QAM
Target Coding Rate		3/4	3/4	3/4	3/4	3/4	3/4
Number of HARQ Processes	Processes	7	7	7	7	7	7
Maximum number of HARQ transmissions		1	1	1	1	1	1
Information Bit Payload per Sub-Frame							
For Sub-Frames 4,9	Bits	2984	8504	14112	30576	46888	61664
For Sub-Frames 1,6	Bits	N/A	6968	11448	23688	35160	46888
For Sub-Frame 5	Bits	N/A	N/A	N/A	N/A	N/A	N/A
For Sub-Frame 0	Bits	N/A	6968	12576	30576	45352	61664
Transport block CRC	Bits	24	24	24	24	24	24
Number of Code Blocks per Sub-Frame (Note 4)							
For Sub-Frames 4,9		1	2	3	5	8	11
For Sub-Frames 1,6		N/A	2	2	4	6	8
For Sub-Frame 5		N/A	N/A	N/A	N/A	N/A	N/A
For Sub-Frame 0		N/A	2	3	5	8	11
Binary Channel Bits per Sub-Frame							
For Sub-Frames 4,9	Bits	4104	11340	18900	41400	62100	82800
For Sub-Frames 1,6		N/A	9828	16668	33768	50868	67968
For Sub-Frame 5	Bits	N/A	N/A	N/A	N/A	N/A	N/A
For Sub-Frame 0	Bits	N/A	9252	16812	39312	60012	80712
Max. Throughput averaged over 1 frame	kbps	596.8	3791.2	6369.6	13910	20945	27877
Note 1:	For normal subframes(0,4,5,9), 2 symbols allocated to PDCCH for 20 MHz, 15 MHz and 10 MHz channel BW; 3 symbols allocated to PDCCH for 5 MHz and 3 MHz; 4 symbols allocated to PDCCH for 1.4 MHz. For special subframe (1&6), only 2 OFDM symbols are allocated to PDCCH for all BWs.						
Note 2:	For 1.4MHz, no data shall be scheduled on special subframes(1&6) to avoid problems with insufficient PDCCH performance.						
Note 3:	Reference signal, Synchronization signals and PBCH allocated as per TS 36.211 [4].						
Note 4:	If more than one Code Block is present, an additional CRC sequence of L = 24 Bits is attached to each Code Block (otherwise L = 0 Bit).						
Note 5:	As per Table 4.2-2 in TS 36.211 [4].						

Table A.3.2-4a Fixed Reference Channel for Maximum input level for UE Category 1 (TDD)

Parameter	Unit	Value					
Channel bandwidth	MHz	1.4	3	5	10	15	20
Allocated resource blocks		6	15	18	17	17	17
Subcarriers per resource block		12	12	12	12	12	12
Uplink-Downlink Configuration (Note 5)		1	1	1	1	1	1
Allocated subframes per Radio Frame		2	3+2	3+2	3+2	3+2	3+2
Modulation		64QAM	64QAM	64QAM	64QAM	64QAM	64QAM
Target Coding Rate		3/4	3/4	3/4	3/4	3/4	3/4
Number of HARQ Processes	Processes	7	7	7	7	7	7
Maximum number of HARQ transmissions		1	1	1	1	1	1
Information Bit Payload per Sub-Frame							
For Sub-Frames 4,9	Bits	2984	8504	10296	10296	10296	10296
For Sub-Frames 1,6	Bits	N/A	6968	8248	7480	7480	7480
For Sub-Frame 5	Bits	N/A	N/A	N/A	N/A	N/A	N/A
For Sub-Frame 0	Bits	N/A	6968	8248	10296	10296	10296
Transport block CRC	Bits	24	24	24	24	24	24
Number of Code Blocks per Sub-Frame (Note 4)							
For Sub-Frames 4,9		1	2	2	2	2	2
For Sub-Frames 1,6		N/A	2	2	2	2	2
For Sub-Frame 5		N/A	N/A	N/A	N/A	N/A	N/A
For Sub-Frame 0		N/A	2	2	2	2	2
Binary Channel Bits per Sub-Frame							
For Sub-Frames 4,9	Bits	4104	11340	13608	14076	14076	14076
For Sub-Frames 1,6		N/A	9828	11880	11628	11628	11628
For Sub-Frame 5	Bits	N/A	N/A	N/A	N/A	N/A	N/A
For Sub-Frame 0	Bits	N/A	9252	11520	14076	14076	14076
Max. Throughput averaged over 1 frame	kbps	596.8	3791.2	4533.6	4584.8	4584.8	4584.8
Note 1:	For normal subframes(0,4,5,9), 2 symbols allocated to PDCCH for 20 MHz, 15 MHz and 10 MHz channel BW; 3 symbols allocated to PDCCH for 5 MHz and 3 MHz; 4 symbols allocated to PDCCH for 1.4 MHz. For special subframe (1&6), only 2 OFDM symbols are allocated to PDCCH for all BWs.						
Note 2:	For 1.4MHz, no data shall be scheduled on special subframes(1&6) to avoid problems with insufficient PDCCH performance.						
Note 3:	Reference signal, Synchronization signals and PBCH allocated as per TS 36.211 [4].						
Note 4:	If more than one Code Block is present, an additional CRC sequence of L = 24 Bits is attached to each Code Block (otherwise L = 0 Bit).						
Note 5:	As per Table 4.2-2 in TS 36.211 [4].						

Table A.3.2-4b Fixed Reference Channel for Maximum input level for UE Category 2 (TDD)

Parameter	Unit	Value					
Channel bandwidth	MHz	1.4	3	5	10	15	20
Allocated resource blocks		6	15	25	50	75	83
Subcarriers per resource block		12	12	12	12	12	12
Uplink-Downlink Configuration (Note 5)		1	1	1	1	1	1
Allocated subframes per Radio Frame		2	3+2	3+2	3+2	3+2	3+2
Modulation		64QAM	64QAM	64QAM	64QAM	64QAM	64QAM
Target Coding Rate		3/4	3/4	3/4	3/4	3/4	3/4
Number of HARQ Processes	Processes	7	7	7	7	7	7
Maximum number of HARQ transmissions		1	1	1	1	1	1
Information Bit Payload per Sub-Frame							
For Sub-Frames 4,9	Bits	2984	8504	14112	30576	46888	51024
For Sub-Frames 1,6	Bits	N/A	6968	11448	23688	35160	39232
For Sub-Frame 5	Bits	N/A	N/A	N/A	N/A	N/A	N/A
For Sub-Frame 0	Bits	N/A	6968	12576	30576	45352	51024
Transport block CRC	Bits	24	24	24	24	24	24
Number of Code Blocks per Sub-Frame (Note 4)							
For Sub-Frames 4,9		1	2	3	5	8	9
For Sub-Frames 1,6		N/A	2	3	5	7	7
For Sub-Frame 5		N/A	N/A	N/A	N/A	N/A	N/A
For Sub-Frame 0		N/A	2	3	5	8	9
Binary Channel Bits per Sub-Frame							
For Sub-Frames 4,9	Bits	4104	11340	18900	41400	62100	68724
For Sub-Frames 1,6		N/A	9828	16668	33768	50868	56340
For Sub-Frame 5	Bits	N/A	N/A	N/A	N/A	N/A	N/A
For Sub-Frame 0	Bits	N/A	9252	16380	39312	60012	66636
Max. Throughput averaged over 1 frame	kbps	596.8	3791.2	6369.6	13910	20945	23154
Note 1:	For normal subframes(0,4,5,9), 2 symbols allocated to PDCCH for 20 MHz, 15 MHz and 10 MHz channel BW; 3 symbols allocated to PDCCH for 5 MHz and 3 MHz; 4 symbols allocated to PDCCH for 1.4 MHz. For special subframe (1&6), only 2 OFDM symbols are allocated to PDCCH for all BWs.						
Note 2:	For 1.4MHz, no data shall be scheduled on special subframes(1&6) to avoid problems with insufficient PDCCH performance.						
Note 3:	Reference signal, Synchronization signals and PBCH allocated as per TS 36.211 [4].						
Note 4:	If more than one Code Block is present, an additional CRC sequence of L = 24 Bits is attached to each Code Block (otherwise L = 0 Bit).						
Note 5:	As per Table 4.2-2 in TS 36.211 [4].						

Table A.3.2-4c Fixed Reference Channel for Maximum input level for UE DL Category 0 (TDD)

Parameter	Unit	Value					
Channel bandwidth	MHz	1.4	3	5	10	15	20
Allocated resource blocks		2	2	2	2	2	2
Subcarriers per resource block		12	12	12	12	12	12
Uplink-Downlink Configuration (Note 5)		1	1	1	1	1	1
Allocated subframes per Radio Frame		2	3+2	3+2	3+2	3+2	3+2
Modulation		64QAM	64QAM	64QAM	64QAM	64QAM	64QAM
Target Coding Rate		3/4	3/4	3/4	3/4	3/4	3/4
Number of HARQ Processes	Processes	7	7	7	7	7	7
Maximum number of HARQ transmissions		1	1	1	1	1	1
Information Bit Payload per Sub-Frame							
For Sub-Frames 4,9	Bits	1000	1000	1000	1000	1000	1000
For Sub-Frames 1,6	Bits	N/A	712	712	712	712	712
For Sub-Frame 5	Bits	N/A	N/A	N/A	N/A	N/A	N/A
For Sub-Frame 0	Bits	N/A	1000	1000	1000	1000	1000
Transport block CRC	Bits	24	24	24	24	24	24
Number of Code Blocks per Sub-Frame (Note 4)							
For Sub-Frames 4,9		1	1	1	1	1	1
For Sub-Frames 1,6		N/A	1	1	1	1	1
For Sub-Frame 5		N/A	N/A	N/A	N/A	N/A	N/A
For Sub-Frame 0		N/A	1	1	1	1	1
Binary Channel Bits per Sub-Frame							
For Sub-Frames 4,9	Bits	1368	1512	1512	1656	1656	1656
For Sub-Frames 1,6		N/A	1224	1224	1368	1368	1368
For Sub-Frame 5	Bits	N/A	N/A	N/A	N/A	N/A	N/A
For Sub-Frame 0	Bits	N/A	1512	1512	1656	1656	1656
Max. Throughput averaged over 1 frame	kbps	200	442.4	442.4	442.4	442.4	442.4
Note 1:	For normal subframes(0,4,5,9), 2 symbols allocated to PDCCH for 20 MHz, 15 MHz and 10 MHz channel BW; 3 symbols allocated to PDCCH for 5 MHz and 3 MHz; 4 symbols allocated to PDCCH for 1.4 MHz. For special subframe (1&6), only 2 OFDM symbols are allocated to PDCCH for all BWs.						
Note 2:	For 1.4MHz, no data shall be scheduled on special subframes(1&6) to avoid problems with insufficient PDCCH performance.						
Note 3:	Reference signal, Synchronization signals and PBCH allocated as per TS 36.211 [4].						
Note 4:	If more than one Code Block is present, an additional CRC sequence of L = 24 Bits is attached to each Code Block (otherwise L = 0 Bit).						
Note 5:	As per Table 4.2-2 in TS 36.211 [4].						



**Table A.3.2-4d Fixed Reference Channel for Maximum input level for UE Categories  $\geq 3$  (TDD Band 46)**

Parameter	Unit	Value
Channel bandwidth	MHz	20
Allocated resource blocks		100
Uplink-Downlink Configuration		N/A
Subcarriers per resource block		12
Allocated subframes per Radio Frame (D)		8
Modulation		64QAM
Target Coding Rate		3/4
Number of HARQ Processes	Processes	N/A
Maximum number of HARQ transmissions		N/A
Information Bit Payload per Sub-Frame		
For Sub-Frames 3,4,6,7,8,9	Bits	61664
For Sub-Frame 1,2	Bits	N/A
For Sub-Frame 0,5	Bits	61664
Transport block CRC	Bits	24
Number of Code Blocks per Sub-Frame (Note 3)		
For Sub-Frames 3,4,6,7,8,9		11
For Sub-Frame 1,2		N/A
For Sub-Frame 0,5		11
Binary Channel Bits Per Sub-Frame		
For Sub-Frames 3,4,6,7,8,9	Bits	82800
For Sub-Frame 1,2	Bits	N/A
For Sub-Frame 0,5	Bits	81936
Max. Throughput averaged over 1 frame	kbps	49331.2
Note 1: 2 symbols allocated to PDCCH for 20 MHz.		
Note 2: Reference signal, Synchronization signals allocated as per TS 36.211 [4].		
Note 3: If more than one Code Block is present, an additional CRC sequence of L = 24 Bits is attached to each Code Block (otherwise L = 0 Bit).		

Table A.3.2-4e Fixed Reference Channel for Maximum input level for UE DL Category M1 (TDD)

Parameter	Unit	Value					
Channel bandwidth	MHz	1.4	3	5	10	15	20
Allocated resource blocks		2	2	2	2	2	2
Subcarriers per resource block		12	12	12	12	12	12
Uplink-Downlink Configuration (Note 5)		1	1	1	1	1	1
Allocated subframes per Radio Frame		2	2	2	2	2	2
Modulation		16QAM	16QAM	16QAM	16QAM	16QAM	16QAM
Target Coding Rate		3/5	3/5	3/5	3/5	3/5	3/5
Number of HARQ Processes	Processes	7	7	7	7	7	7
Maximum number of HARQ transmissions		1	1	1	1	1	1
Information Bit Payload per Sub-Frame							
For Sub-Frames 4,9	Bits	552	552	552	552	552	552
For Sub-Frames 1,6	Bits	N/A	N/A	N/A	N/A	N/A	N/A
For Sub-Frame 5	Bits	N/A	N/A	N/A	N/A	N/A	N/A
For Sub-Frame 0	Bits	N/A	N/A	N/A	N/A	N/A	N/A
Transport block CRC	Bits	24	24	24	24	24	24
Number of Code Blocks per Sub-Frame (Note 4)							
For Sub-Frames 4,9		1	1	1	1	1	1
For Sub-Frames 1,6		N/A	N/A	N/A	N/A	N/A	N/A
For Sub-Frame 5		N/A	N/A	N/A	N/A	N/A	N/A
For Sub-Frame 0		N/A	N/A	N/A	N/A	N/A	N/A
Binary Channel Bits per Sub-Frame							
For Sub-Frames 4,9	Bits	912	1008	1008	1008	1008	1008
For Sub-Frames 1,6		N/A	N/A	N/A	N/A	N/A	N/A
For Sub-Frame 5	Bits	N/A	N/A	N/A	N/A	N/A	N/A
For Sub-Frame 0	Bits	N/A	N/A	N/A	N/A	N/A	N/A
Max. Throughput averaged over 1 frame	kbps	110.4	110.4	110.4	110.4	110.4	110.4
Note 1:	For normal subframes(0,4,5,9), 4 symbols allocated to PDCCH for 1.4MHz channel bandwidth and 3 symbols allocated to PDCCH for all other channel bandwidths. For special subframe (1&6), only 2 OFDM symbols are allocated to PDCCH for all BWs.						
Note 2:	For 1.4MHz, no data shall be scheduled on special subframes(1&6) to avoid problems with insufficient PDCCH performance.						
Note 3:	Reference signal, Synchronization signals and PBCH allocated as per TS 36.211 [4].						
Note 4:	If more than one Code Block is present, an additional CRC sequence of L = 24 Bits is attached to each Code Block (otherwise L = 0 Bit).						
Note 5:	As per Table 4.2-2 in TS 36.211 [4].						
Note 6:	2 resource blocks allocated to MPDCCH.						

Table A.3.2-4f: Fixed Reference Channel for Maximum input level for UE DL Category M2 (TDD)

Parameter	Unit	Value					
Channel bandwidth	MHz	1.4	3	5	10	15	20
Allocated resource blocks (Note 7)		2	8	15	15	15	15
Subcarriers per resource block		12	12	12	12	12	12
Uplink-Downlink Configuration (Note 5)		1	1	1	1	1	1
Allocated subframes per Radio Frame		2	2	2	2	2	2
Modulation		16QAM	16QAM	16QAM	16QAM	16QAM	16QAM
Target Coding Rate		3/5	3/5	1/2	1/2	1/2	1/2
Number of HARQ Processes	Processes	7	7	7	7	7	7
Maximum number of HARQ transmissions		1	1	1	1	1	1
Information Bit Payload per Sub-Frame							
For Sub-Frames 4,9	Bits	552	2280	4008	4008	4008	4008
For Sub-Frames 1,6	Bits	N/A	N/A	N/A	N/A	N/A	N/A
For Sub-Frame 5	Bits	N/A	N/A	N/A	N/A	N/A	N/A
For Sub-Frame 0	Bits	N/A	N/A	N/A	N/A	N/A	N/A
Transport block CRC	Bits	24	24	24	24	24	24
Number of Code Blocks per Sub-Frame (Note 4)							
For Sub-Frames 4,9		1	1	1	1	1	1
For Sub-Frames 1,6		N/A	N/A	N/A	N/A	N/A	N/A
For Sub-Frame 5		N/A	N/A	N/A	N/A	N/A	N/A
For Sub-Frame 0		N/A	N/A	N/A	N/A	N/A	N/A
Binary Channel Bits per Sub-Frame							
For Sub-Frames 4,9	Bits	912	4032	7560	7560	7560	7560
For Sub-Frames 1,6		N/A	N/A	N/A	N/A	N/A	N/A
For Sub-Frame 5	Bits	N/A	N/A	N/A	N/A	N/A	N/A
For Sub-Frame 0	Bits	N/A	N/A	N/A	N/A	N/A	N/A
Max. Throughput averaged over 1 frame	kbps	110.4	456.0	801.6	801.6	801.6	801.6
Note 1:	For normal subframes(0,4,5,9), 4 symbols allocated to PDCCH for 1.4MHz channel bandwidth, and 3 symbols allocated for all other channel bandwidths. For special subframe (1&6), only 2 OFDM symbols are allocated to PDCCH for all BWs.						
Note 2:	For 1.4MHz, no data shall be scheduled on special subframes(1&6) to avoid problems with insufficient PDCCH performance.						
Note 3:	Reference signal, Synchronization signals and PBCH allocated as per TS 36.211 [4].						
Note 4:	If more than one Code Block is present, an additional CRC sequence of L = 24 Bits is attached to each Code Block (otherwise L = 0 Bit).						
Note 5:	As per Table 4.2-2 in TS 36.211 [4].						
Note 6:	2 resource blocks allocated to MPDCCH.						
Note 7:	2 resource blocks allocated to PDSCH for 1.4MHz channel bandwidth. 2 narrowbands and 4 resource blocks in each narrowband allocated to PDSCH for 3MHz channel bandwidth. For 5MHz/10MHz/15MHz/20MHz channel bandwidth, configure 3 narrowbands and 5 resource blocks in each narrowband allocated to PDSCH.						

**Table A.3.2-5 Fixed Reference Channel for Maximum input level for UE Categories 11/12 and UE DL categories  $\geq 11$  (FDD)**

Parameter	Unit	Value					
		1.4	3	5	10	15	20
Channel bandwidth	MHz	1.4	3	5	10	15	20
Allocated resource blocks		6	15	25	50	75	100
Subcarriers per resource block		12	12	12	12	12	12
Allocated subframes per Radio Frame		8	9	9	9	9	9
Modulation		256QAM	256QAM	256QAM	256QAM	256QAM	256QAM
Target Coding Rate		4/5	4/5	4/5	4/5	4/5	4/5
Number of HARQ Processes	Processes	8	8	8	8	8	8
Maximum number of HARQ transmissions		1	1	1	1	1	1
Information Bit Payload per Sub-Frame							
For Sub-Frames 1,2,3,4,6,7,8,9	Bits	4392	12216	19848	42368	63776	84760
For Sub-Frame 5	Bits	N/A	N/A	N/A	N/A	N/A	N/A
For Sub-Frame 0	Bits	N/A	9912	17568	40576	63776	84760
Transport block CRC	Bits	24	24	24	24	24	24
Number of Code Blocks per Sub-Frame (Note 3)							
For Sub-Frames 1,2,3,4,6,7,8,9		1	2	4	7	11	14
For Sub-Frame 5		N/A	N/A	N/A	N/A	N/A	N/A
For Sub-Frame 0		N/A	2	3	7	11	14
Binary Channel Bits Per Sub-Frame							
For Sub-Frames 1,2,3,4,6,7,8,9	Bits	5472	15120	25200	55200	82800	110400
For Sub-Frame 5	Bits	N/A	N/A	N/A	N/A	N/A	N/A
For Sub-Frame 0	Bits	N/A	12210	22290	51840	79440	107040
Max. Throughput averaged over 1 frame	kbps	3513.6	10764	17635.2	37952	57398.4	76284
Note 1:	2 symbols allocated to PDCCH for 20 MHz, 15 MHz and 10 MHz channel BW. 3 symbols allocated to PDCCH for 5 MHz and 3 MHz. 4 symbols allocated to PDCCH for 1.4 MHz.						
Note 2:	Reference signal, Synchronization signals and PBCH allocated as per TS 36.211 [4].						
Note 3:	If more than one Code Block is present, an additional CRC sequence of L = 24 Bits is attached to each Code Block (otherwise L = 0 Bit).						

**Table A.3.2-6 Fixed Reference Channel for Maximum input level for UE Categories 11/12 and UE DL categories  $\geq 11$  (TDD)**

Parameter	Unit	Value					
		1.4	3	5	10	15	20
Channel bandwidth	MHz	1.4	3	5	10	15	20
Allocated resource blocks		6	15	25	50	75	100
Subcarriers per resource block		12	12	12	12	12	12
Uplink-Downlink Configuration (Note 5)		1	1	1	1	1	1
Allocated subframes per Radio Frame		2	3+2	3+2	3+2	3+2	3+2
Modulation		256QAM	256QAM	256QAM	256QAM	256QAM	256QAM
Target Coding Rate		4/5	4/5	4/5	4/5	4/5	4/5
Number of HARQ Processes	Processes	7	7	7	7	7	7
Maximum number of HARQ transmissions		1	1	1	1	1	1
Information Bit Payload per Sub-Frame							
For Sub-Frames 4,9	Bits	4392	12216	19848	42368	63776	84760
For Sub-Frames 1,6	Bits	N/A	10680	17568	36696	55056	75376
For Sub-Frame 5	Bits	N/A	N/A	N/A	N/A	N/A	N/A
For Sub-Frame 0	Bits	N/A	9912	17568	42368	63776	84760
Transport block CRC	Bits	24	24	24	24	24	24
Number of Code Blocks per Sub-Frame (Note 4)							
For Sub-Frames 4,9		1	2	4	7	11	14
For Sub-Frames 1,6		N/A	2	3	6	9	13
For Sub-Frame 5		N/A	N/A	N/A	N/A	N/A	N/A
For Sub-Frame 0		N/A	2	3	7	11	14
Binary Channel Bits per Sub-Frame							
For Sub-Frames 4,9	Bits	5472	15120	25200	55200	82800	110400
For Sub-Frames 1,6		N/A	13104	22224	45024	67824	90624
For Sub-Frame 5	Bits	N/A	N/A	N/A	N/A	N/A	N/A
For Sub-Frame 0	Bits	N/A	12336	22416	52416	80016	107616
Max. Throughput averaged over 1 frame	kbps	878.4	5570.4	9240	20049.6	30144	40503.2
Note 1:	For normal subframes(0,4,5,9), 2 symbols allocated to PDCCH for 20 MHz, 15 MHz and 10 MHz channel BW; 3 symbols allocated to PDCCH for 5 MHz and 3 MHz; 4 symbols allocated to PDCCH for 1.4 MHz. For special subframe (1&6), only 2 OFDM symbols are allocated to PDCCH for all BWs.						
Note 2:	For 1.4MHz, no data shall be scheduled on special subframes(1&6) to avoid problems with insufficient PDCCH performance.						
Note 3:	Reference signal, Synchronization signals and PBCH allocated as per TS 36.211 [4].						
Note 4:	If more than one Code Block is present, an additional CRC sequence of L = 24 Bits is attached to each Code Block (otherwise L = 0 Bit).						
Note 5:	As per Table 4.2-2 in TS 36.211 [4].						

**Table A.3.2-7 Fixed Reference Channel for Maximum input level for UE Categories 11/12 and UE DL categories  $\geq 11$  (TDD Band 46)**

Parameter	Unit	Value
Channel bandwidth	MHz	20
Allocated resource blocks		100
Uplink-Downlink Configuration		N/A
Subcarriers per resource block		12
Allocated subframes per Radio Frame (D)		8
Modulation		256QAM
Target Coding Rate		4/5
Number of HARQ Processes	Processes	N/A
Maximum number of HARQ transmissions		N/A
Information Bit Payload per Sub-Frame		
For Sub-Frames 3,4,6,7,8,9	Bits	84760
For Sub-Frame 1,2	Bits	N/A
For Sub-Frame 0,5	Bits	84760
Transport block CRC	Bits	24
Number of Code Blocks per Sub-Frame (Note 3)		
For Sub-Frames 3,4,6,7,8,9		14
For Sub-Frame 1,2		N/A
For Sub-Frame 0,5		14
Binary Channel Bits Per Sub-Frame		
For Sub-Frames 3,4,6,7,8,9	Bits	110400
For Sub-Frame 1,2	Bits	N/A
For Sub-Frame 0,5	Bits	109248
Max. Throughput averaged over 1 frame	kbps	67808
Note 1:	2 symbols allocated to PDCCH for 20 MHz.	
Note 2:	Reference signal, Synchronization signals allocated as per TS 36.211 [4].	
Note 3:	If more than one Code Block is present, an additional CRC sequence of L = 24 Bits is attached to each Code Block (otherwise L = 0 Bit).	

**Table A.3.2-8 Fixed Reference Channel for Maximum input level for UE DL category 20 and UE DL categories  $\geq 22$  (FDD)**

Parameter	Unit	Value					
		1.4	3	5	10	15	20
Channel bandwidth	MHz	1.4	3	5	10	15	20
Allocated resource blocks		6	15	25	50	75	100
Subcarriers per resource block		12	12	12	12	12	12
Allocated subframes per Radio Frame		8	9	9	9	9	9
Modulation		1024QAM	1024QAM	1024QAM	1024QAM	1024QAM	1024QAM
Target Coding Rate		4/5	4/5	4/5	4/5	4/5	4/5
Number of HARQ Processes	Processes	8	8	8	8	8	8
Maximum number of HARQ transmissions		1	1	1	1	1	1
Information Bit Payload per Sub-Frame							
For Sub-Frames 1,2,3,4,6,7,8,9	Bits	6456	15840	26416	55056	81176	110136
For Sub-Frame 5	Bits	N/A	N/A	N/A	N/A	N/A	N/A
For Sub-Frame 0	Bits	N/A	11832	21384	52752	78704	105528
Transport block CRC	Bits	24	24	24	24	24	24
Number of Code Blocks per Sub-Frame (Note 3)							
For Sub-Frames 1,2,3,4,6,7,8,9		2	3	5	9	14	18
For Sub-Frame 5		N/A	N/A	N/A	N/A	N/A	N/A
For Sub-Frame 0		N/A	2	4	9	13	18
Binary Channel Bits Per Sub-Frame							
For Sub-Frames 1,2,3,4,6,7,8,9	Bits	7560	18900	31500	69000	103500	138000
For Sub-Frame 5	Bits	N/A	N/A	N/A	N/A	N/A	N/A
For Sub-Frame 0	Bits	N/A	14700	27300	64800	99300	133800
Max. Throughput averaged over 1 frame	kbps	5164.8	13855.2	23271.2	49320	72811.2	98661.6
<p>Note 1: 2 symbols allocated to PDCCH for 20 MHz, 15 MHz and 10 MHz channel BW. 3 symbols allocated to PDCCH for 5 MHz, 3 MHz and 1.4 MHz.</p> <p>Note 2: Reference signal, Synchronization signals and PBCH allocated as per TS 36.211 [4].</p> <p>Note 3: If more than one Code Block is present, an additional CRC sequence of L = 24 Bits is attached to each Code Block (otherwise L = 0 Bit).</p>							

**Table A.3.2-9 Fixed Reference Channel for Maximum input level for UE DL category 20 and UE DL categories  $\geq 22$  (TDD)**

Parameter	Unit	Value					
		1.4	3	5	10	15	20
Channel bandwidth	MHz	1.4	3	5	10	15	20
Allocated resource blocks		6	15	25	50	75	100
Subcarriers per resource block		12	12	12	12	12	12
Uplink-Downlink Configuration (Note 5)		1	1	1	1	1	1
Allocated subframes per Radio Frame		2	3+2	3+2	3+2	3+2	3+2
Modulation		1024QAM	1024QAM	1024QAM	1024QAM	1024QAM	1024QAM
Target Coding Rate		4/5	4/5	4/5	4/5	4/5	4/5
Number of HARQ Processes	Processes	7	7	7	7	7	7
Maximum number of HARQ transmissions		1	1	1	1	1	1
Information Bit Payload per Sub-Frame							
For Sub-Frames 4,9	Bits	6456	15840	26416	55056	81176	110136
For Sub-Frames 1,6	Bits	N/A	12960	22152	45352	66592	90816
For Sub-Frame 5	Bits	N/A	N/A	N/A	N/A	N/A	N/A
For Sub-Frame 0	Bits	N/A	12216	22920	52752	78704	105528
Transport block CRC	Bits	24	24	24	24	24	24
Number of Code Blocks per Sub-Frame (Note 4)							
For Sub-Frames 4,9		2	3	5	9	14	18
For Sub-Frames 1,6		N/A	3	4	8	11	15
For Sub-Frame 5		N/A	N/A	N/A	N/A	N/A	N/A
For Sub-Frame 0		N/A	2	4	9	13	18
Binary Channel Bits per Sub-Frame							
For Sub-Frames 4,9	Bits	7560	18900	31500	69000	103500	138000
For Sub-Frames 1,6		N/A	16380	27780	56280	84780	113280
For Sub-Frame 5	Bits	N/A	N/A	N/A	N/A	N/A	N/A
For Sub-Frame 0	Bits	N/A	15420	28020	65520	100020	134520
Max. Throughput averaged over 1 frame	kbps	1291.2	6981.6	12005.6	25356.8	37424	50743.2
Note 1:	For normal subframes(0,4,5,9), 2 symbols allocated to PDCCH for 20 MHz, 15 MHz and 10 MHz channel BW; 3 symbols allocated to PDCCH for 5 MHz, 3 MHz and 1.4 MHz. For special subframe (1&6), only 2 OFDM symbols are allocated to PDCCH for all BWs.						
Note 2:	For 1.4MHz, no data shall be scheduled on special subframes(1&6) to avoid problems with insufficient PDCCH performance.						
Note 3:	Reference signal, Synchronization signals and PBCH allocated as per TS 36.211 [4].						
Note 4:	If more than one Code Block is present, an additional CRC sequence of L = 24 Bits is attached to each Code Block (otherwise L = 0 Bit).						
Note 5:	As per Table 4.2-2 in TS 36.211 [4].						



**Table A.3.2-10 Fixed Reference Channel for Maximum input level for UE DL category 20 and UE DL categories  $\geq 22$  (TDD Band 46)**

Parameter	Unit	Value
Channel bandwidth	MHz	20
Allocated resource blocks		100
Uplink-Downlink Configuration		N/A
Subcarriers per resource block		12
Allocated subframes per Radio Frame (D)		8
Modulation		1024QAM
Target Coding Rate		4/5
Number of HARQ Processes	Processes	N/A
Maximum number of HARQ transmissions		N/A
Information Bit Payload per Sub-Frame		
For Sub-Frames 3,4,6,7,8,9	Bits	110136
For Sub-Frame 1,2	Bits	N/A
For Sub-Frame 0,5	Bits	110136
Transport block CRC	Bits	24
Number of Code Blocks per Sub-Frame (Note 3)		
For Sub-Frames 3,4,6,7,8,9		18
For Sub-Frame 1,2		N/A
For Sub-Frame 0,5		18
Binary Channel Bits Per Sub-Frame		
For Sub-Frames 3,4,6,7,8,9	Bits	138000
For Sub-Frame 1,2	Bits	N/A
For Sub-Frame 0,5	Bits	136560
Max. Throughput averaged over 1 frame	kbps	88108.8
Note 1:	2 symbols allocated to PDCCH for 20 MHz.	
Note 2:	Reference signal, Synchronization signals allocated as per TS 36.211 [4].	
Note 3:	If more than one Code Block is present, an additional CRC sequence of L = 24 Bits is attached to each Code Block (otherwise L = 0 Bit).	

### A.3.3 Reference measurement channels for PDSCH performance requirements (FDD)

#### A.3.3.1 Single-antenna transmission (Common Reference Symbols)

**Table A.3.3.1-1: Fixed Reference Channel QPSK R=1/3**

Parameter	Unit	Value					
		R.4 FDD	R.42 FDD	R.42-1 FDD	R.42-2 FDD	R.42-3 FDD	R.2 FDD
Reference channel							
Channel bandwidth	MHz	1.4	20	3	5	15	10
Allocated resource blocks (Note 4)		6	100	15	25	75	50
Allocated subframes per Radio Frame		9	9	9	9	9	9
Modulation		QPSK	QPSK	QPSK	QPSK	QPSK	QPSK
Target Coding Rate		1/3	1/3	1/3	1/3	1/3	1/3
Information Bit Payload (Note 4)							
For Sub-Frames 1,2,3,4,6,7,8,9	Bits	408	8760	1320	2216	6712	4392
For Sub-Frame 5	Bits	N/A	N/A	N/A	N/A	N/A	N/A
For Sub-Frame 0	Bits	152	8760	1064	1800	6712	4392
Number of Code Blocks (Notes 3 and 4)							
For Sub-Frames 1,2,3,4,6,7,8,9		1	2	1	1	2	1
For Sub-Frame 5		N/A	N/A	N/A	N/A	N/A	N/A
For Sub-Frame 0		1	2	1	1	2	1
Binary Channel Bits (Note 4)							
For Sub-Frames 1,2,3,4,6,7,8,9	Bits	1368	27600	3780	6300	20700	13800
For Sub-Frame 5	Bits	N/A	N/A	N/A	N/A	N/A	N/A
For Sub-Frame 0	Bits	528	26760	2940	5460	19860	12960
Max. Throughput averaged over 1 frame (Note 4)	Mbps	0.342	7.884	1.162	1.953	6.041	3.953
UE Category		≥ 1	≥ 1	≥ 1	≥ 1	≥ 1	≥ 1
Note 1:	2 symbols allocated to PDCCH for 20 MHz, 15 MHz and 10 MHz channel BW; 3 symbols allocated to PDCCH for 5 MHz and 3 MHz; 4 symbols allocated to PDCCH for 1.4 MHz.						
Note 2:	Reference signal, synchronization signals and PBCH allocated as per TS 36.211 [4].						
Note 3:	If more than one Code Block is present, an additional CRC sequence of L = 24 Bits is attached to each Code Block (otherwise L = 0 Bit).						
Note 4:	Given per component carrier per codeword.						

Table A.3.3.1-2: Fixed Reference Channel 16QAM R=1/2

Parameter	Unit	Value					
				R.3-1 FDD	R.3 FDD		
Reference channel							
Channel bandwidth	MHz	1.4	3	5	10	15	20
Allocated resource blocks				25	50		
Allocated subframes per Radio Frame				9	9		
Modulation				16QAM	16QAM		
Target Coding Rate				1/2	1/2		
Information Bit Payload							
For Sub-Frames 1,2,3,4,6,7,8,9	Bits			6456	14112		
For Sub-Frame 5	Bits			N/A	N/A		
For Sub-Frame 0	Bits			5736	12960		
Number of Code Blocks per Sub-Frame (Note 3)							
For Sub-Frames 1,2,3,4,6,7,8,9				2	3		
For Sub-Frame 5				N/A	N/A		
For Sub-Frame 0				1	3		
Binary Channel Bits Per Sub-Frame							
For Sub-Frames 1,2,3,4,6,7,8,9	Bits			12600	27600		
For Sub-Frame 5	Bits			N/A	N/A		
For Sub-Frame 0	Bits			10920	25920		
Max. Throughput averaged over 1 frame	Mbps			5.738	12.586		
UE Category				≥ 1	≥ 2		
Note 1: 2 symbols allocated to PDCCH for 20 MHz, 15 MHz and 10 MHz channel BW; 3 symbols allocated to PDCCH for 5 MHz and 3 MHz; 4 symbols allocated to PDCCH for 1.4 MHz.							
Note 2: Reference signal, synchronization signals and PBCH allocated as per TS 36.211 [4].							
Note 3: If more than one Code Block is present, an additional CRC sequence of L = 24 Bits is attached to each Code Block (otherwise L = 0 Bit).							

Table A.3.3.1-3: Fixed Reference Channel 64QAM R=3/4

Parameter	Unit	Value						
			R.5 FDD	R.6 FDD	R.7 FDD	R.8 FDD	R.9 FDD	
Reference channel								
Channel bandwidth	MHz	1.4	3	5	10	15	20	
Allocated resource blocks			15	25	50	75	100	
Allocated subframes per Radio Frame			9	9	9	9	9	
Modulation		64QAM	64QAM	64QAM	64QAM	64QAM	64QAM	
Target Coding Rate		3/4	3/4	3/4	3/4	3/4	3/4	
Information Bit Payload								
For Sub-Frames 1,2,3,4,6,7,8,9	Bits		8504	14112	30576	46888	61664	
For Sub-Frame 5	Bits		N/A	N/A	N/A	N/A	N/A	
For Sub-Frame 0	Bits		6456	12576	28336	45352	61664	
Number of Code Blocks per Sub-Frame (Note 3)								
For Sub-Frames 1,2,3,4,6,7,8,9			2	3	5	8	11	
For Sub-Frame 5			N/A	N/A	N/A	N/A	N/A	
For Sub-Frame 0			2	3	5	8	11	
Binary Channel Bits Per Sub-Frame								
For Sub-Frames 1,2,3,4,6,7,8,9	Bits		11340	18900	41400	62100	82800	
For Sub-Frame 5	Bits		N/A	N/A	N/A	N/A	N/A	
For Sub-Frame 0	Bits		8820	16380	38880	59580	80280	
Max. Throughput averaged over 1 frame	Mbps		7.449	12.547	27.294	42.046	55.498	
UE Category			≥ 1	≥ 2	≥ 2	≥ 2	≥ 3	
Note 1: 2 symbols allocated to PDCCH for 20 MHz, 15 MHz and 10 MHz channel BW; 3 symbols allocated to PDCCH for 5 MHz and 3 MHz; 4 symbols allocated to PDCCH for 1.4 MHz.								
Note 2: Reference signal, synchronization signals and PBCH allocated as per TS 36.211 [4].								
Note 3: If more than one Code Block is present, an additional CRC sequence of L = 24 Bits is attached to each Code Block (otherwise L = 0 Bit).								

Table A.3.3.1-3a: Fixed Reference Channel 64QAM R=3/4

Parameter	Unit	Value				
		R.6-1 FDD	R.7-1 FDD	R.8-1 FDD	R.9-1 FDD	R.9-2 FDD
Reference channel						
Channel bandwidth	MHz	5	10	15	20	20
Allocated resource blocks (Note 3)		18	17	17	17	83
Allocated subframes per Radio Frame		9	9	9	9	9
Modulation		64QAM	64QAM	64QAM	64QAM	64QAM
Target Coding Rate		3/4	3/4	3/4	3/4	3/4
Information Bit Payload						
For Sub-Frames 1,2,3,4,6,7,8,9	Bits	10296	10296	10296	10296	51024
For Sub-Frame 5	Bits	N/A	N/A	N/A	N/A	N/A
For Sub-Frame 0	Bits	8248	10296	10296	10296	51024
Number of Code Blocks per Sub-Frame (Note 4)						
For Sub-Frames 1,2,3,4,6,7,8,9		2	2	2	2	9
For Sub-Frame 5		N/A	N/A	N/A	N/A	N/A
For Sub-Frame 0		2	2	2	2	9
Binary Channel Bits Per Sub-Frame						
For Sub-Frames 1,2,3,4,6,7,8,9	Bits	13608	14076	14076	14076	68724
For Sub-Frame 5	Bits	N/A	N/A	N/A	N/A	N/A
For Sub-Frame 0	Bits	11088	14076	14076	14076	66204
Max. Throughput averaged over 1 frame	Mbps	9.062	9.266	9.266	9.266	45.922
UE Category		≥ 1	≥ 1	≥ 1	≥ 1	≥ 2
Note 1: 2 symbols allocated to PDCCH for 20 MHz, 15 MHz and 10 MHz channel BW; 3 symbols allocated to PDCCH for 5 MHz and 3 MHz; 4 symbols allocated to PDCCH for 1.4 MHz.						
Note 2: Reference signal, synchronization signals and PBCH allocated as per TS 36.211 [4].						
Note 3: Localized allocation started from RB #0 is applied.						
Note 4: If more than one Code Block is present, an additional CRC sequence of L = 24 Bits is attached to each Code Block (otherwise L = 0 Bit).						

Table A.3.3.1-4: Fixed Reference Channel Single PRB (Channel Edge)

Parameter	Unit	Value				
		R.0 FDD		R.1 FDD		
Reference channel						
Channel bandwidth	MHz	1.4	3	5	10/20	15
Allocated resource blocks			1		1	
Allocated subframes per Radio Frame			9		9	
Modulation			16QAM		16QAM	
Target Coding Rate			1/2		1/2	
Information Bit Payload						
For Sub-Frames 1,2,3,4,6,7,8,9	Bits		224		256	
For Sub-Frame 5	Bits		N/A		N/A	
For Sub-Frame 0	Bits		224		256	
Number of Code Blocks per Sub-Frame (Note 3)						
For Sub-Frames 1,2,3,4,6,7,8,9			1		1	
For Sub-Frame 5			N/A		N/A	
For Sub-Frame 0			1		1	
Binary Channel Bits Per Sub-Frame						
For Sub-Frames 1,2,3,4,6,7,8,9	Bits		504		552	
For Sub-Frame 5	Bits		N/A		N/A	
For Sub-Frame 0	Bits		504		552	
Max. Throughput averaged over 1 frame	Mbps		0.202		0.230	
UE Category			≥ 1		≥ 1	
Note 1: 2 symbols allocated to PDCCH for 20 MHz, 15 MHz and 10 MHz channel BW; 3 symbols allocated to PDCCH for 5 MHz and 3 MHz; 4 symbols allocated to PDCCH for 1.4 MHz.						
Note 2: Reference signal, synchronization signals and PBCH allocated as per TS 36.211 [4].						
Note 3: If more than one Code Block is present, an additional CRC sequence of L = 24 Bits is attached to each Code Block (otherwise L = 0 Bit).						

Table A.3.3.1-5: Fixed Reference Channel Single PRB (MBSFN Configuration)

Parameter	Unit	Value	
		R.29 FDD (MBSFN)	R.29-1 FDD (MBSFN)
Reference channel		R.29 FDD (MBSFN)	R.29-1 FDD (MBSFN)
Channel bandwidth	MHz	10	10
Allocated resource blocks		1	1
MBSFN Configuration		111111 (Note 4)	11111111 (Note 5)
Allocated subframes per Radio Frame		3	3
Modulation		16QAM	16QAM
Target Coding Rate		1/2	1/2
Information Bit Payload			
For Sub-Frames 4,9	Bits	256	0 (MBSFN)
For Sub-Frame 5	Bits	N/A	N/A
For Sub-Frame 0	Bits	256	256
For Sub-Frame 1,2,3,6,7,8	Bits	0 (MBSFN)	0 (MBSFN)
Number of Code Blocks per Sub-Frame (Note 3)			
For Sub-Frames 4,9		1	0 (MBSFN)
For Sub-Frame 5		N/A	N/A
For Sub-Frame 0		1	1
For Sub-Frame 1,2,3,6,7,8		0 (MBSFN)	0 (MBSFN)
Binary Channel Bits Per Sub-Frame			
For Sub-Frames 4,9	Bits	552	0 (MBSFN)
For Sub-Frame 5	Bits	N/A	N/A
For Sub-Frame 0	Bits	552	552
For Sub-Frame 1,2,3,6,7,8	Bits	0 (MBSFN)	0 (MBSFN)
Max. Throughput averaged over 1 frame	kbps	76.8	25.6
UE Category		≥ 1	≥ 1
Note 1: 2 symbols allocated to PDCCH.			
Note 2: Reference signal, synchronization signals and PBCH allocated as per TS 36.211 [4].			
Note 3: If more than one Code Block is present, an additional CRC sequence of L = 24 Bits is attached to each Code Block (otherwise L = 0 Bit).			
Note 4: MBSFN Subframe Allocation as defined in TS 36.331 [7], one frame with 6 bits is chosen for MBSFN subframe allocation			
Note 5: MBSFN Subframe Allocation as defined in TS 36.331 [7], one frame with 6 bits and MBSFN Subframe Allocation-v14xy in TS 36.331 [7], one frame with 2 bits, are chosen for MBSFN subframe allocation.			

Table A.3.3.1-6: Fixed Reference Channel QPSK R=1/10

Parameter	Unit	Value					
					R.41 FDD		
Reference channel							
Channel bandwidth	MHz	1.4	3	5	10	15	20
Allocated resource blocks					50		
Allocated subframes per Radio Frame					9		
Modulation					QPSK		
Target Coding Rate					1/10		
Information Bit Payload							
For Sub-Frames 1,2,3,4,6,7,8,9	Bits				1384		
For Sub-Frame 5	Bits				N/A		
For Sub-Frame 0	Bits				1384		
Number of Code Blocks per Sub-Frame (Note 3)							
For Sub-Frames 1,2,3,4,6,7,8,9					1		
For Sub-Frame 5					N/A		
For Sub-Frame 0					1		
Binary Channel Bits Per Sub-Frame							
For Sub-Frames 1,2,3,4,6,7,8,9	Bits				13800		
For Sub-Frame 5	Bits				N/A		
For Sub-Frame 0	Bits				12960		
Max. Throughput averaged over 1 frame	Mbps				1.246		
UE Category					≥ 1		
Note 1:	2 symbols allocated to PDCCH for 20 MHz, 15 MHz and 10 MHz channel BW; 3 symbols allocated to PDCCH for 5 MHz and 3 MHz; 4 symbols allocated to PDCCH for 1.4 MHz.						
Note 2:	Reference signal, synchronization signals and PBCH allocated as per TS 36.211 [4].						
Note 3:	If more than one Code Block is present, an additional CRC sequence of L = 24 Bits is attached to each Code Block (otherwise L = 0 Bit).						

Table A.3.3.1-7: Fixed Reference Channel for CA demodulation with power imbalance

Parameter	Unit	Value		
		R.49 FDD	R.49-1 FDD	R.49-2 FDD
Reference channel				
Channel bandwidth	MHz	20	10	5
Allocated resource blocks		100	50	25
Allocated subframes per Radio Frame		9	9	9
Modulation		64QAM	64QAM	64QAM
Coding Rate				
For Sub-Frame 1,2,3,4,6,7,8,9		0.84	0.84	0.84
For Sub-Frame 5		N/A	N/A	N/A
For Sub-Frame 0		0.87	0.87	0.86
Information Bit Payload				
For Sub-Frames 1,2,3,4,6,7,8,9	Bits	63776	31704	15840
For Sub-Frame 5	Bits	N/A	N/A	N/A
For Sub-Frame 0	Bits	63776	30576	14112
Number of Code Blocks per Sub-Frame (Note 3)				
For Sub-Frames 0,1,2,3,4,6,7,8,9	Code Blocks	11	6	3
For Sub-Frame 5	Code Blocks	N/A	N/A	N/A
Binary Channel Bits Per Sub-Frame			5	3
For Sub-Frames 1,2,3,4,6,7,8,9	Bits	75600		
For Sub-Frame 5	Bits	N/A	37800	18900
For Sub-Frame 0	Bits	73080	N/A	N/A
Max. Throughput averaged over 1 frame	Mbps	57.398	35280	16380
UE Category		≥ 5	≥ 2	≥ 2
Note 1:	3 symbols allocated to PDCCH.			
Note 2:	Reference signal, synchronization signals and PBCH allocated as per TS 36.211 [4].			
Note 3:	If more than one Code Block is present, an additional CRC sequence of L = 24 Bits is attached to each Code Block (otherwise L = 0 Bit).			

## A.3.3.2 Multi-antenna transmission (Common Reference Symbols)

## A.3.3.2.1 Two antenna ports

Table A.3.3.2.1-1: Fixed Reference Channel two antenna ports

Parameter	Unit	Value											
		R.10 FDD	R.11 FDD	R.11-1 FDD	R.11-2 FDD	R.11-3 FDD Note 5	R.11-4 FDD	R.30 FDD	R.30-1 FDD	R.35-1 FDD	R.35 FDD	R.35-2 FDD	R.35-3 FDD
Reference channel													
Channel bandwidth	MHz	10	10	10	5	10	10	20	15	20	10	15	10
Allocated resource blocks (Note 4)		50	50	50	25	40	50	100	75	100	50	75	50
Allocated subframes per Radio Frame		9	9	8	9	9	9	9	8	8	9	8	8
Modulation		QPSK	16QAM	16QAM	16QAM	16QAM	QPSK	16QAM	16QAM	64QAM	64QAM	64QAM	64QAM
Target Coding Rate		1/3	1/2	1/2	1/2	1/2	1/2	1/2	1/2	0.39	1/2	0.39	0.39
Information Bit Payload (Note 4)													
For Sub-Frames 1,2,3,4,6,7,8,9	Bits	4392	12960	12960	5736	10296	6968	25456	19080	30576	19848	22920	15264
For Sub-Frame 5	Bits	N/A	N/A	N/A	N/A	N/A	N/A	N/A	N/A	N/A	N/A	N/A	N/A
For Sub-Frame 0	Bits	4392	12960	N/A	4968	10296	6968	25456	N/A	N/A	18336	N/A	N/A
Number of Code Blocks (Notes 3 and 4)													
For Sub-Frames 1,2,3,4,6,7,8,9	Bits	1	3	3	1	2	2	5	4	5	4	4	3
For Sub-Frame 5	Bits	N/A	N/A	N/A	N/A	N/A	N/A	N/A	N/A	N/A	N/A	N/A	N/A
For Sub-Frame 0	Bits	1	3	N/A	1	2	2	5	N/A	N/A	3	N/A	N/A
Binary Channel Bits (Note 4)													
For Sub-Frames 1,2,3,4,6,7,8,9	Bits	13200	26400	26400	12000	21120	13200	52800	39600	79200	39600	59400	39600
For Sub-Frame 5	Bits	N/A	N/A	N/A	N/A	N/A	N/A	N/A	N/A	N/A	N/A	N/A	N/A
For Sub-Frame 0	Bits	12384	24768	N/A	10368	19488	12384	51168	N/A	N/A	37152	N/A	N/A
Max. Throughput averaged over 1 frame (Note 4)	Mbps	3.953	11.664	10.368	5.086	9.266	6.271	22.910	15.264	24.461	17.712	18.336	12.211
UE Category		≥ 1	≥ 2	≥ 2	≥ 1	≥ 1	≥ 1	≥ 2	≥ 2	4	≥ 2	≥ 2	≥ 2
Note 1:	2 symbols allocated to PDCCH for 20 MHz, 15 MHz and 10 MHz channel BW; 3 symbols allocated to PDCCH for 5 MHz and 3 MHz; 4 symbols allocated to PDCCH for 1.4 MHz.												
Note 2:	Reference signal, synchronization signals and PBCH allocated as per TS 36.211 [4].												
Note 3:	If more than one Code Block is present, an additional CRC sequence of L = 24 Bits is attached to each Code Block (otherwise L = 0 Bit).												
Note 4:	Given per component carrier per codeword.												
Note 5:	For R.11-3 resource blocks of RB6–RB45 are allocated.												

Table A.3.3.2.1-2: Fixed Reference Channel two antenna ports

Parameter	Unit	Value											
		R.46 FDD	R.47 FDD	R.35-4 FDD	R.11-5 FDD	R.11-6 FDD	R.11-7 FDD	R.11-8 FDD	R.11-9 FDD	R.11-10 FDD	R.65 FDD	R.10-2 FDD	R.10-3 FDD
Reference channel													
Channel bandwidth	MHz	10	10	10	1.4	3	15	10	10	10	10	5	10
Allocated resource blocks (Note 4)		50	50	50	6	15	75	50	50	50	50	25	50
Allocated number of PDCCH symbols		2	2	2	4	3	2	2	3	3	2	3	2
Allocated subframes per Radio Frame		9	9	9	8	9	9	9	8	8	8	9	9
Modulation		QPSK	16QA M	64QA M	16QA M	16QA M	16QA M	QPSK	QPSK	QPSK	256QA M	QPSK	16QA M
Target Coding Rate				0.47	1/2	1/2	1/2	3/5	0.58	0.67	0.55	1/3	0.58
Information Bit Payload (Note 4)													
For Sub-Frames 1,2,3,4,6,7,8,9	Bits	5160	8760	18336	1352	3368	19080	7992	6968	7992	31704	1800	15264
For Sub-Frame 5	Bits	N/A	N/A	N/A	N/A	N/A	N/A	N/A	N/A	N/A	N/A	n/a	n/a
For Sub-Frame 0	Bits	5160	8760	16416	N/A	2664	19080	6968	N/A	N/A	N/A	1800	14112
Number of Code Blocks (Notes 3 and 4)													
For Sub-Frames 1,2,3,4,6,7,8,9	Bits	1	2	3	1	1	4	2	2	2	6	1	3
For Sub-Frame 5	Bits	N/A	N/A	N/A	N/A	N/A	N/A	N/A	N/A	N/A	N/A	n/a	n/a
For Sub-Frame 0	Bits	1	2	3	1	1	4	2	N/A	N/A	N/A	1	3
Binary Channel Bits (Note 4)													
For Sub-Frames 1,2,3,4,6,7,8,9	Bits	13200	26400	39600	2592	7200	39600	13200	12000	12000	57600	6000	26400
For Sub-Frame 5	Bits	N/A	N/A	N/A	N/A	N/A	N/A	N/A	N/A	N/A	N/A	n/a	n/a
For Sub-Frame 0	Bits	12384	24768	37152	N/A	5568	37968	12384	N/A	N/A	N/A	5184	24768
Max. Throughput averaged over 1 frame (Note 4)	Mbps	4.644	7.884	16.310	1.082	2.961	17.172	7.0904	5.5744	6.3936	25.363	1.620	13.6224
UE Category		≥ 1	≥ 1	≥ 2	≥ 1	≥ 1	≥ 2	≥ 2	≥ 1	≥ 1	11-12	≥ 1	≥ 2
UE DL Category		≥ 6	≥ 6	≥ 6	≥ 6	≥ 6	≥ 6	≥ 6			≥ 11	≥ 6	
Note 1:	Void												
Note 2:	Reference signal, synchronization signals and PBCH allocated as per TS 36.211 [4]												
Note 3:	If more than one Code Block is present, an additional CRC sequence of L = 24 Bits is attached to each Code Block (otherwise L = 0 Bit)												
Note 4:	Given per component carrier per codeword.												



Table A.3.3.2.1-3: Fixed Reference Channel two antenna ports

Parameter	Unit	Value	
		R.62 FDD	R.63 FDD
Reference channel		R.62 FDD	R.63 FDD
Channel bandwidth	MHz	10	10
Allocated resource blocks (Note 4)		3	1
Allocated DL subframes per 4 Radio Frames (Note 3)		15	15
Modulation		16QAM	64QAM
Target Coding Rate		1/2	1/2
Information Bit Payload			
For Sub-Frames 0,1,2,3,4,5,6,7,8,9	Bits	744	408
Number of Code Blocks			
For Sub-Frames 0,1,2,3,4,5,6,7,8,9	Code blocks	1	1
Binary Channel Bits			
For Sub-Frames 0,1,2,3,4,5,6,7,8,9	Bits	1584	792
Max. Throughput averaged over 4 frames	Mbps	0.279	0.153
UE DL Category		0	0
Note 1:	2 symbols allocated to PDCCH		
Note 2:	Reference signal, synchronization signals and PBCH allocated as per TS 36.211 [4]		
Note 3:	The downlink subframes are scheduled at the 0th, 1st, 2nd, 8th, 9th, 10th, 16th, 17th, 18th, 24th, 25th, 26th, 32nd, 33rd, 34th subframes every 40ms. Information bit payload is available if downlink subframe is scheduled.		
Note 4:	Allocated PRB positions start from {9, 10, ..., 9+N-1}, where N is the number of allocated resource blocks.		

Table A.3.3.2.1-4: Fixed Reference Channel two antenna ports

Parameter	Unit	Values		
		R.79 FDD	R.103 FDD	R.104 FDD
Reference channel		R.79 FDD	R.103 FDD	R.104 FDD
Channel bandwidth	MHz	10	10	10
Allocated resource blocks (Note 4)		3	3	3
Allocated DL subframes per Radio Frame		Note 3	Note 5	Note 3
Modulation		16QAM	QPSK	64QAM
Target Coding Rate		1/2	1/3	0.4
Information Bit Payload				
For Sub-Frames 0,1,2,3,4,5,6,7,8,9	Bits	744	224	968
Number of Code Blocks				
For Sub-Frames 0,1,2,3,4,5,6,7,8,9	Code blocks	1	1	1
Binary Channel Bits				
For Sub-Frames 0,1,2,3,4,5,6,7,8,9	Bits	1584	792	2376
Max. Throughput averaged over 1 frame	Mbps	0.149	0.020	0.194
UE DL Category		M1, M2 ≥ 0	M1, M2	M1, M2
Note 1:	2 symbols allocated to PDCCH.			
Note 2:	Reference signal, synchronization signals and PBCH allocated as per TS 36.211 [4].			
Note 3:	The downlink subframes are scheduled at the 0th and 1st subframes every 10ms. Information bit payload is available if downlink subframe is scheduled (starting from 0th subframe). The corresponding MPDCCH is scheduled 2 subframes before the corresponding PDSCH transmissions.			
Note 4:	Allocated PRB positions for PDSCH are {3, 4, 5} within the assigned narrowband. Allocated PRB positions for MPDCCH are {0, 1} within the assigned narrowband.			
Note 5:	The downlink subframes are scheduled at the 0th subframes every 11ms. Information bit payload is available if downlink subframe is scheduled (starting from 0th subframe). The corresponding MPDCCH is scheduled 5 subframes before the corresponding PDSCH transmissions.			

Table A.3.3.2.1-5: Fixed Reference Channel two antenna ports

Parameter	Unit	Values		
		R.81 FDD	R.81-1 FDD	R.81-2 FDD
Reference channel		R.81 FDD	R.81-1 FDD	R.81-2 FDD
Channel bandwidth	MHz	10	10	10
Allocated resource blocks (Note 4)		6	6	6
Allocated PDSCH subframes		(Note 3)	(Note 6)	(Note 7)
Modulation		QPSK	QPSK	QPSK
Target Coding Rate		1/10	1/10	1/10
Information Bit Payload				
For Sub-Frames 0,1,2,3,4,5,6,7,8,9	Bits	152	152	152
Number of Code Blocks				
For Sub-Frames 0,1,2,3,4,5,6,7,8,9	Code blocks	1	1	1
Binary Channel Bits				
For Sub-Frames 0,1,2,3,4,5,6,7,8,9	Bits	1584	1584	1584
Max. Throughput averaged over one period	kbps	0.950	1.9	4.75
UE DL Category		M1, ≥ 0	≥ 1	≥ 1
Note 1: 2 symbols allocated to PDCCH Note 2: Reference signal, synchronization signals and PBCH allocated as per TS 36.211 [4] Note 3: PDSCH subframes are scheduled at the 65th to 128th subframes every period=160 ms. Information bit payload is available at the 65th to 128th subframes with repetition. (Starting from the 0th subframe) Note 4: Allocated PRB positions are {0, 1, 2, 3, 4, 5} within the assigned narrowband. Note 5: MPDCCH are scheduled at the 0th to 63rd subframes with repetition. The allocated PRB positions are {0, 1, 2, 3, 4, 5} within the assigned narrowband. (Starting from the 0th subframe) Note 6: PDSCH subframes are scheduled at the 33th to 64th subframes every period=80 ms. Information bit payload is available at the 33th to 64th subframes with repetition. (Starting from the 0th subframe) Note 7: PDSCH subframes are scheduled at the 9th to 24th subframes every period=32 ms. Information bit payload is available at the 9th to 24th subframes with repetition. (Starting from the 0th subframe)				

Table A.3.3.2.1-6: Fixed Reference Channel two antenna ports

Parameter	Unit	Values							
		R.87 FDD	R.87-1 FDD	R.84 FDD	R.aa FDD	R.bb FDD	R.87-2 FDD	R.87-3 FDD	R.87-4 FDD
Reference channel		R.87 FDD	R.87-1 FDD	R.84 FDD	R.aa FDD	R.bb FDD	R.87-2 FDD	R.87-3 FDD	R.87-4 FDD
Channel bandwidth	MHz	10	10	10	10	10	5	15	20
Allocated resource blocks (Note 4)		50	50	39	50	50	25	75	100
Allocated number of PDCCH symbols		2	2	2	2	2	2	2	2
Allocated subframes per Radio subframes		8	8	9	9	9	8	8	8

Modulation		64QAM	16QAM	16QAM	QPSK	16QAM	64QAM	64QAM	64QAM
Target Coding Rate									
For Sub-Frames 1,2,3,4,6,7,8,9		0.39	0.44	1/2	0.6	0.3	0.39	0.39	0.39
For Sub-Frames 5		N/A	N/A	N/A	N/A	N/A	N/A	N/A	N/A
For Sub-Frames 0		N/A	N/A	N/A	0.65	0.32	N/A	N/A	N/A
Information Bit Payload (Note 4)									
For Sub-Frames 1,2,3,4,6,7,8,9	Bits	15264	11448	9912	7992	7992	7736	22920	30576
For Sub-Frames 5	Bits	N/A	N/A	N/A	N/A	N/A	N/A	N/A	N/A
For Sub-Frames 0		N/A	N/A	9912	7992	7992	N/A	N/A	N/A
Number of Code Blocks (Notes 3 and 4)									
For Sub-Frames 1,2,3,4,6,7,8,9		3	2	2	2	2	2	4	5
For Sub-Frames 5		N/A	N/A	N/A	N/A	N/A	N/A	N/A	N/A
For Sub-Frames 0		N/A	N/A	2	2	2	N/A	N/A	N/A
Binary Channel Bits (Note 4)									
For Sub-Frames 1,2,3,4,6,7,8,9	Bits	39600	26400	20592	13200	26400	19800	59400	79200
For Sub-Frames 5		N/A	N/A	N/A	N/A	N/A	N/A	N/A	N/A
For Sub-Frames 0		N/A	N/A	20592	12384	24768	N/A	N/A	N/A
Max. Throughput averaged over 1 frame (Note 4)	Mbps	12.211	9.158	8.9208	7.1928	7.1928	6.1888	18.336	24.461
UE Category		≥ 1	≥ 1	1bis	≥ 1	≥ 2	≥ 1	≥ 1	≥ 1
UE DL Category		≥ 6	≥ 6	N/A	≥ 6	≥ 6	≥ 6	≥ 6	≥ 6
Note 1:	Void								
Note 2:	Reference signal, synchronization signals and PBCH allocated as per TS 36.211 [4]								
Note 3:	If more than one Code Block is present, an additional CRC sequence of L = 24 Bits is attached to each Code Block (otherwise L = 0 Bit)								
Note 4:	Given per component carrier per codeword.								
Note 5:	For R.84 FDD, 39 RBs are allocated on RB 0-20 and 30-47.								

Table A.3.3.2.1-7: Fixed Reference Channel two antenna ports

Parameter	Unit	Value		
		R.47-1 FDD	R.47-2 FDD	R.47-3 FDD
Reference channel				
Channel bandwidth	MHz	5	15	20
Allocated resource blocks (Note 4)		25	75	100
Allocated number of PDCCH symbols		2	2	2
Allocated subframes per Radio Frame		9	9	9
Modulation		16QAM	16QAM	16QAM
Target Coding Rate				
Information Bit Payload (Note 4)				
For Sub-Frames 1,2,3,4,6,7,8,9	Bits	4008	12960	17568
For Sub-Frame 5	Bits	N/A	N/A	N/A
For Sub-Frame 0	Bits	3496	12960	17568
Number of Code Blocks				
For Sub-Frames 1,2,3,4,6,7,8,9	Bits	1	3	3
For Sub-Frame 5	Bits	N/A	N/A	N/A
For Sub-Frame 0	Bits	1	3	3
Binary Channel Bits (Note 3)				
For Sub-Frames 1,2,3,4,6,7,8,9	Bits	12000	39600	52800
For Sub-Frame 5	Bits	N/A	N/A	N/A
For Sub-Frame 0	Bits	10368	37968	51168
Max. Throughput averaged over 1 frame (Note 3)	Mbps	3.556	11.664	15.811 2
UE Category		≥ 1	≥ 1	≥ 1
UE DL Category		≥ 6	≥ 6	≥ 6
Note 1: Reference signal, synchronization signals and PBCH allocated as per TS 36.211 [4]				
Note 2: If more than one Code Block is present, an additional CRC sequence of L = 24 Bits is attached to each Code Block (otherwise L = 0 Bit)				
Note 3: Given per component carrier per codeword.				

Table A.3.3.2.1-8: Fixed Reference Channel two antenna ports

Parameter	Unit	Values			
		R.90 FDD	R.91 FDD	R.92-1 FDD	R.92-2 FDD
Reference channel					
Channel bandwidth	MHz	10	10	10	10
Allocated resource blocks		18 (Note 7)	18 (Note 7)	36 (Note 8)	36 (Note 8)
Allocated DL subframes		Note 3	Note 4	Note 5	Note 6
Modulation		QPSK	QPSK	QPSK	QPSK
Target Coding Rate		1/3	1/10	1/2	1/2
Information Bit Payload					
For Sub-Frames 0,1,2,3,4,5,6,7,8,9	Bits	1544	488	4392	4392
Number of Code Blocks					
For Sub-Frames 0,1,2,3,4,5,6,7,8,9	Code blocks	1	1	1	1
Binary Channel Bits					
For Sub-Frames 0,1,2,3,4,5,6,7,8,9	Bits	4752	4752	9504	9504
Max. Throughput averaged over one period	kbps	48.25	3.8125	219.6	439.2
UE DL Category		M2	M2	≥ 1	≥ 1
Note 1:	2 symbols allocated to PDCCH				
Note 2:	Reference signal, synchronization signals and PBCH allocated as per TS 36.211 [4]				
Note 3:	The downlink subframes are scheduled at the 0th to 24th subframes every period=32 ms. Information bit payload is available at the 17th to 24th subframes with repetition. MPDCCH are scheduled at the 0th to 15th subframes with repetition. (Starting from the 0th subframe)				
Note 4:	The downlink subframes are scheduled at the 0th to 96th subframes every period=128 ms. Information bit payload is available at the 65th to 96th subframes with repetition. MPDCCH are scheduled at the 0th to 63rd subframes with repetition. (Starting from the 0th subframe)				
Note 5:	The downlink subframes are scheduled at the 0th to 12th subframes every period= 20 ms. Information bit payload is available at the 9th to 12th subframes with repetition. MPDCCH are scheduled at the 0th to 7th subframes with repetition. (Starting from the 0th subframe)				
Note 6:	The downlink subframes are scheduled at the 0th to 4th subframes every period=10 ms. Information bit payload is available at the 3rd to 4th subframes with repetition. MPDCCH are scheduled at the 0th to 1st subframes with repetition. (Starting from the 0th subframe)				
Note 7:	Allocated PRB positions are {0, 1, ..., 17} within the assigned wideband.				
Note 8:	Allocated PRB positions are {1, 2, 3, ..., 18, 31, 32, ..., 48}.				
Note 9:	Allocated PRB positions for MPDCCH are {0, 1, 2, 3, 4, 5} within the scheduled narrowband.				

Table A.3.3.2.1-9: Fixed Reference Channel two antenna ports

Parameter	Unit	Value	
Reference channel		R.11-13 FDD	
Channel bandwidth	MHz	10	
Allocated resource blocks (Note 4)		50	
Allocated subframes per Radio Frame		9	
Modulation		16QAM	
Target Coding Rate		1/2	
Information Bit Payload (Note 4)			
For Sub-Frames 1,2,3,4,6,7,8,9	Bits	10680	
For Sub-Frame 5	Bits	N/A	
For Sub-Frame 0	Bits	10680	
Number of Code Blocks (Notes 3 and 4)			
For Sub-Frames 1,2,3,4,6,7,8,9	Bits	2	
For Sub-Frame 5	Bits	N/A	
For Sub-Frame 0	Bits	2	
Binary Channel Bits (Note 4)			
For Sub-Frames 1,2,3,4,6,7,8,9	Bits	21648	
For Sub-Frame 5	Bits	N/A	
For Sub-Frame 0	Bits	17424	
Max. Throughput averaged over 1 frame (Note 4)	Mbps	9.612	
UE Category		$\geq 2$	
Note 1: 2 symbols allocated to PDCCH. Note 2: Reference signal, synchronization signals and PBCH allocated as per TS 36.211 [4]. Note 3: If more than one Code Block is present, an additional CRC sequence of L = 24 Bits is attached to each Code Block (otherwise L = 0 Bit). Note 4: Given per component carrier per codeword. Note 5: 41 resource blocks (RB0–RB20 and RB30–RB49) are allocated in sub-frame 0,1,2,3,4,6,7,8,9.			

## A.3.3.2.2 Four antenna ports

Table A.3.3.2.2-1: Fixed Reference Channel four antenna ports

Parameter	Unit	Value												
		R.12 FDD	R.13 FDD	R.14 FDD	R.14-1 FDD	R.14-2 FDD	R.14-3 FDD	R.36 FDD	R.14-4 FDD	R.14-5 FDD	R.14-6 FDD	R.14-7 FDD	R.36-1 FDD	
Reference channel														
Channel bandwidth	MHz	1.4	10	10	10	10	20	10	1.4	3	5	15	10	
Allocated resource blocks (Note 4)		6	50	50	6	3	100	50	6	15	25	75	50	
Allocated subframes per Radio Frame		9	9	9	8	8	9	9	8	9	9	9	9	
Modulation		QPSK	QPSK	16QAM	16QAM	16QAM	16QAM	64QAM	16QAM	16QAM	16QAM	16QAM	64QAM	
Target Coding Rate		1/3	1/3	1/2	1/2	1/2	1/2	1/2	1/2	1/2	1/2	1/2	0.55	
Information Bit Payload (Note 4)														
For Sub-Frames 1,2,3,4,6,7,8,9	Bits	408	4392	12960	1544	744	25456	18336	1192	3368	5736	19080	21384	
For Sub-Frame 5	Bits	N/A	N/A	N/A	N/A	N/A	n/a	N/A	N/A	N/A	N/A	N/A	N/A	
For Sub-Frame 0	Bits	152	3624	11448	N/A	N/A	22920	18336	N/A	2664	4968	19080	19848	
Number of Code Blocks (Notes 3 and 4)														
For Sub-Frames 1,2,3,4,6,7,8,9		1	1	3	1	1	5	3	1	1	1	4	4	
For Sub-Frame 5		N/A	N/A	N/A	N/A	N/A	n/a	N/A	N/A	N/A	N/A	N/A	N/A	
For Sub-Frame 0		1	1	2	N/A	N/A	4	3	N/A	1	1	4	4	
Binary Channel Bits (Note 4)														
For Sub-Frames 1,2,3,4,6,7,8,9	Bits	1248	12800	25600	3072	1536	51200	38400	2496	6960	11600	38400	38400	
For Sub-Frame 5	Bits	N/A	N/A	N/A	N/A	N/A	n/a	N/A	N/A	N/A	N/A	N/A	N/A	
For Sub-Frame 0	Bits	480	12032	24064	N/A	N/A	49664	36096	N/A	5424	10064	36864	36096	
Max. Throughput averaged over 1 frame (Note 4)	Mbps	0.342	3.876	11.513	1.235	0.595	22.656	16.502	0.954	2.961	5.086	17.172	19.092	
UE Category		≥ 1	≥ 1	≥ 2	≥ 1	≥ 1	≥ 2	≥ 2	≥ 1	≥ 1	≥ 1	≥ 2	≥ 2	
Note 1:	2 symbols allocated to PDCCH for 20 MHz, 15 MHz and 10 MHz channel BW; 3 symbols allocated to PDCCH for 5 MHz and 3 MHz; 4 symbols allocated to PDCCH for 1.4 MHz.													
Note 2:	Reference signal, synchronization signals and PBCH allocated as per TS 36.211 [4].													
Note 3:	If more than one Code Block is present, an additional CRC sequence of L = 24 Bits is attached to each Code Block (otherwise L = 0 Bit).													
Note 4:	Given per component carrier per codeword.													

**Table A.3.3.2.2-2: Fixed Reference Channel four antenna ports**

*ETSI*



Parameter	Unit	Value								
		R.72 FDD	R.72-1 FDD	R.72-2 FDD	R.72-3 FDD	R.73 FDD	R.73-1 FDD	R.74 FDD	R.85 FDD	R.93 FDD
Reference channel										
Channel bandwidth	MHz	10	5	15	20	10	10	10	10	10
Allocated resource blocks (Note 4)		50	25	75	100	50	50	50	24 (Note 5)	24 (Note 5)
Allocated subframes per Radio Frame		9	9	9	9	9	9	9	9	9
Modulation		256QAM	256QAM	256QAM	256QAM	64QAM	16QAM	16QAM	64QAM	64QAM
Target Coding Rate		0.62	0.69	0.61	0.62	0.43	1/2	1/2	1/2	0.52
Information Bit Payload (Note 4)										
For Sub-Frames 1,2,3,4,6,7,8,9	Bits	31704	15840	46888	63776	16416 (CW0) 32856 (CW1)	12960 (CW0) 25456 (CW1)	25456	10296	9528
For Sub-Frame 5	Bits	N/A	N/A	N/A	N/A	N/A	N/A	N/A	N/A	N/A
For Sub-Frame 0	Bits	31704	15840	46888	63776	15264 (CW0) 30576 (CW1)	11448 (CW0) 22920 (CW1)	22920	10296	9528
Number of Code Blocks (Notes 3 and 4)										
For Sub-Frames 1,2,3,4,6,7,8,9		6	3	8	11	3 (CW0) 6 (CW1)	3 (CW0) 5 (CW1)	5	2	2
For Sub-Frame 5		N/A	N/A	N/A	N/A	N/A	N/A	N/A	N/A	N/A
For Sub-Frame 0		6	3	8	11	3 (CW0) 5 (CW1)	2 (CW0) 4 (CW1)	5	2	2
Binary Channel Bits (Note 4)										
For Sub-Frames 1,2,3,4,6,7,8,9	Bits	51200	23200	76800	102400	38400 (CW0) 76800 (CW1)	25600 (CW0) 51200 (CW1)	51200	18432	18432
For Sub-Frame 5	Bits	N/A	N/A	N/A	N/A	N/A	N/A	N/A	N/A	N/A
For Sub-Frame 0	Bits	48128	20128	73728	99328	36096 (CW0) 72192 (CW1)	24064 (CW0) 48128 (CW1)	48128	18432	18432
Max. Throughput averaged over 1 frame (Note 4)	Mbps	28.534	14.256	42.1992	57.3984	14.659 (CW0) 29.342 (CW1)	11.513 (CW0) 22.657 (CW1)	22.657	9.2664	8.575
UE Category		≥ 11	≥ 11	≥ 11	≥ 11	≥ 5	≥ 5	≥ 5	1bis	1bis

Note 1:	2 symbols allocated to PDCCH for 20 MHz, 15 MHz and 10 MHz channel BW; 3 symbols allocated to PDCCH for 5 MHz and 3 MHz; 4 symbols allocated to PDCCH for 1.4 MHz.
Note 2:	Reference signal, synchronization signals and PBCH allocated as per TS 36.211 [4].
Note 3:	If more than one Code Block is present, an additional CRC sequence of L = 24 Bits is attached to each Code Block (otherwise L = 0 Bit).
Note 4:	Given per component carrier per codeword.
Note 5:	24 resource blocks (RB 0-20 and 30-32) are allocated in sub-frames 0, 1, 2, 3, 4, 6, 7, 8, 9

Table A.3.3.2.2-3: Fixed Reference Channel four antenna ports

Parameter	Unit	Value			
		R.74-1 FDD	R.74-2 FDD	R.74-3 FDD	R.101 FDD
Reference channel					
Channel bandwidth	MHz	5	15	20	10
Allocated resource blocks (Note 4)		25	75	100	50
Allocated subframes per Radio Frame		9	9	9	9
Modulation		16QAM	16QAM	16QAM	1024QAM
Target Coding Rate		1/2	1/2	1/2	3/4
Information Bit Payload (Note 4)					
For Sub-Frames 1,2,3,4,6,7,8,9	Bits	11448	37888	51024	52752
For Sub-Frame 5	Bits	N/A	N/A	N/A	N/A
For Sub-Frame 0	Bits	9912	37888	51024	N/A
Number of Code Blocks (Notes 3 and 4)					
For Sub-Frames 1,2,3,4,6,7,8,9		2	7	9	9
For Sub-Frame 5		N/A	N/A	N/A	N/A
For Sub-Frame 0		2	7	9	N/A
Binary Channel Bits (Note 4)					
For Sub-Frames 1,2,3,4,6,7,8,9	Bits	23200	76800	102400	68000
For Sub-Frame 5	Bits	N/A	N/A	N/A	N/A
For Sub-Frame 0	Bits	20128	73728	99328	N/A
Max. Throughput averaged over 1 frame (Note 4)	Mbps	10.1496	34.0992	45.9216	42.2016
UE Category		≥ 5	≥ 5	≥ 5	TBD
UE DL Category					20, ≥ 22
Note 1:	2 symbols allocated to PDCCH for 20 MHz, 15 MHz and 10 MHz channel BW; 3 symbols allocated to PDCCH for 5 MHz and 3 MHz; 4 symbols allocated to PDCCH for 1.4 MHz. 1 symbol allocated to PDCCH for reference channel with 1024QAM.				
Note 2:	Reference signal, synchronization signals and PBCH allocated as per TS 36.211 [4].				
Note 3:	If more than one Code Block is present, an additional CRC sequence of L = 24 Bits is attached to each Code Block (otherwise L = 0 Bit).				
Note 4:	Given per component carrier per codeword.				

Table A.3.3.2.2-4: Fixed Reference Channel four antenna ports

Parameter	Unit	Values
Reference channel		R.95 FDD
Channel bandwidth	MHz	10
Allocated resource blocks (Note 4)		3
Allocated DL subframes per Radio Frame (Note 3)		2
Modulation		16QAM
Target Coding Rate		1/2
Information Bit Payload		
For Sub-Frames 0,1,2,3,4,5,6,7,8,9	Bits	744
Number of Code Blocks		
For Sub-Frames 0,1,2,3,4,5,6,7,8,9	Code blocks	1
Binary Channel Bits		
For Sub-Frames 0,1,2,3,4,5,6,7,8,9	Bits	1536
Max. Throughput averaged over 1 frame	Mbps	0.149
UE DL Category		M2
Note 1:	2 symbols allocated to PDCCH.	
Note 2:	Reference signal, synchronization signals and PBCH allocated as per TS 36.211 [4].	
Note 3:	The downlink subframes are scheduled at the 0th and 1st subframes every 10ms. Information bit payload is available if downlink subframe is scheduled (starting from 0th subframe). The corresponding MPDCCH is scheduled 2 subframes before the corresponding PDSCH transmissions.	
Note 4:	Allocated PRB positions for PDSCH are {3, 4, 5} within the assigned narrowband. Allocated PRB positions for MPDCCH are {0, 1} within the assigned narrowband.	

### A.3.3.3 Reference Measurement Channel for UE-Specific Reference Symbols

#### A.3.3.3.0 Two antenna ports (no CSI-RS)

The reference measurement channels in Table A.3.3.3.0-1 apply with two CRS antenna ports and without CSI-RS.

**Table A.3.3.3.0-1: Fixed Reference Channel without CSI-RS**

Parameter	Unit	Value	
		R.70 FDD	R.71 FDD
Reference channel		R.70 FDD	R.71 FDD
Channel bandwidth	MHz	10	10
Allocated resource blocks		50	50
Allocated subframes per Radio Frame		10	10
Modulation		QPSK	16QAM
Target Coding Rate		0.65	0.6
Information Bit Payload			
For Sub-Frames 1,2,3,4,6,7,8,9	Bits	6968	12960
For Sub-Frame 5	Bits	N/A	N/A
For Sub-Frame 0	Bits	N/A	N/A
Number of Code Blocks per Sub-Frame (Note 4)			
For Sub-Frames 1,2,3,4,6,7,8,9		2	3
For Sub-Frame 5		N/A	N/A
For Sub-Frame 0		N/A	N/A
Binary Channel Bits Per Sub-Frame			
For Sub-Frames 1,2,3,4,6,7,8,9	Bits	10800	21600
For Sub-Frame 5	Bits	N/A	N/A
For Sub-Frame 0	Bits	N/A	N/A
Max. Throughput averaged over 1 frame	Mbps	5.5744	10.368
UE Category		≥ 1	≥ 2
Note 1:	3 symbols allocated to PDCCH.		
Note 2:	Reference signal, synchronization signals and PBCH allocated as per TS 36.211 [4]		
Note 3:	If more than one Code Block is present, an additional CRC sequence of L = 24 Bits is attached to each Code Block (otherwise L = 0 Bit)		

The reference measurement channels in Table A.3.3.3.0-2 apply for verifying demodulation performance for UE-specific reference symbols without CSI-RS.

Table A.3.3.3.0-2: Fixed Reference Channel without CSI-RS

Parameter	Unit	Value		
		R.80 FDD	R.80-1 FDD	R.80-2 FDD
Reference channel				
Channel bandwidth	MHz	10	10	10
Allocated resource blocks (Note 4)		6	6	6
Allocated PDSCH subframes		Note 3	Note 6	Note 7
Modulation		QPSK	QPSK	QPSK
Target Coding Rate		1/3	1/3	1/3
Information Bit Payload				
For Sub-Frames 0,1,2,3,4,5,6,7,8,9	Bits	504	504	504
Number of Code Blocks				
For Sub-Frames 0,1,2,3,4,5,6,7,8,9	Code blocks	1	1	1
Binary Channel Bits				
For Sub-Frames 0,1,2,3,4,5,6,7,8,9	Bits	1440	1440	1440
Max. Throughput averaged over one period	kbps	15.75	31.5	50.4
UE DL Category		M1, $\geq 0$	$\geq 1$	$\geq 1$
Note 1:	2 symbols allocated to PDCCCH			
Note 2:	Reference signal, synchronization signals and PBCH allocated as per TS 36.211 [4]			
Note 3:	PDSCH subframes are scheduled at the 9th to 16th subframes every period=32 ms. Information bit payload is available from the 9-th to 16th subframes with repetition. (Starting from the 0th subframe)			
Note 4:	Allocated PRB positions are {0, 1, 2, 3, 4, 5} within the assigned narrowband.			
Note 5:	MPDCCH are scheduled at the 0th to 7th subframes with repetition. The allocated PRB positions are {0, 1, 2, 3, 4, 5} within the assigned narrowband. (Starting from the 0th subframe)			
Note 6:	PDSCH subframes are scheduled at the 3th to 6th subframes every period=16 ms. Information bit payload is available from the 3th to 6th subframes with repetition. (Starting from the 0th subframe)			
Note 7:	PDSCH subframes are scheduled at the 2th to 3th subframes every period=10 ms. Information bit payload is available from the 2th to 3th subframes with repetition. (Starting from the 0th subframe)			

#### A.3.3.3.1 Two antenna port (CSI-RS)

The reference measurement channels in Table A.3.3.3.1-1 apply for verifying demodulation performance for UE-specific reference symbols with two cell-specific antenna ports and two CSI-RS antenna ports.

Table A.3.3.3.1-1: Fixed Reference Channel for CDM-multiplexed DM RS with two CSI-RS antenna ports

Parameter	Unit	Value									
		R.51 FDD	R.51-1 FDD	R.76 FDD	R.51-2 FDD	R.51-3 FDD	R.51-4 FDD	R.86 FDD	R.86A FDD	R.X FDD	R.94 FDD
Reference channel											
Channel bandwidth	MHz	10	10	10	5	15	20	10	10	10	10
Allocated resource blocks		50 (Note 3)	50 (Note 3)	50 (Note 3)	25 (Note 5)	75 (Note 6)	100 (Note 7)	50 (Note 3)	50 (Note 3)	50 (Note 3)	24 (Note 8)
Allocated subframes per Radio Frame		9	9	9	9	9	9	9	9	9	9
Modulation		16QAM	16QAM	QPSK	16QAM	16QAM	16QAM	QPSK	QPSK	64QAM	QPSK
Target Coding Rate		1/2	0.54		1/2	1/2	1/2	1/3	1/3	1/2	2/3
Information Bit Payload											
For Sub-Frames 1,4,6,9	Bits	11448	12960	6200	5736	16992	22920	4392	3624	18336	3752
For Sub-Frames 2,3,7,8	Bits	11448	12960	6200	5736	16992	22920	4392	3624	18336	3752
For Sub-Frame 5	Bits	N/A	N/A	n/a	N/A	N/A	N/A	N/A	N/A	N/A	N/A
For Sub-Frame 0	Bits	9528	10680	4968	3880	14112	19848	3624	2984	14688	3752
Number of Code Blocks (Note 4)											
For Sub-Frames 1,4,6,9	Code blocks	2	3	2	1	3	4	1	1	3	1
For Sub-Frames 2,3,7,8	Code blocks	2	3	2	1	3	4	1	1	3	1
For Sub-Frame 5	Bits	N/A	N/A	n/a	N/A	N/A	N/A	N/A	N/A	N/A	N/A
For Sub-Frame 0	Bits	2	2	1	1	3	4	1	1	3	1
Binary Channel Bits											
For Sub-Frames 1,4,6,9	Bits	24000	24000	12000	10800	36000	48000	12000	11600	36000	5760
For Sub-Frames 2,7		23600	23600	11800	10600	35400	47200	11800	11600	35400	5664
For Sub-Frames 3,8		23200	23200	12000	10400	34800	46400	11600	11200	34800	5568
For Sub-Frame 5	Bits	N/A	N/A	n/a	N/A	N/A	N/A	N/A	N/A	N/A	N/A
For Sub-Frame 0	Bits	19680	19680	9840	6912	30240	42240	11184	9512	29520	5760
Max. Throughput averaged over 1 frame	Mbps	10.1112	11.436	5.4568	4.9768	15.0048	20.3208	3.876	3.1976	16.138	3.376
UE Category		≥ 2	≥ 2	≥ 2	≥ 2	≥ 2	≥ 2	1bis	≥ 1	≥ 2	1bis
Note 1:	2 symbols allocated to PDCCH for 20 MHz, 15 MHz and 10 MHz channel BW; 3 symbols allocated to PDCCH for 5 MHz and 3 MHz; 4 symbols allocated to PDCCH for 1.4 MHz.										
Note 2:	Reference signal, synchronization signals and PBCH allocated as per TS 36.211 [4].										
Note 3:	50 resource blocks are allocated in sub-frames 1, 2, 3, 4, 6, 7, 8, 9 and 41 resource blocks (RB0–RB20 and RB30–RB49) are allocated in sub-frame 0.										
Note 4:	If more than one Code Block is present, an additional CRC sequence of L = 24 Bits is attached to each Code Block (otherwise L = 0 Bit).										
Note 5:	25 resource blocks are allocated in sub-frames 1, 2, 3, 4, 6, 7, 8, 9 and 17 resource blocks (RB0–RB9 and RB18–RB24) are allocated in sub-frame 0.										
Note 6:	75 resource blocks are allocated in sub-frames 1, 2, 3, 4, 6, 7, 8, 9 and 63 resource blocks (RB0–R31 and RB44–RB74) are allocated in sub-frame 0.										
Note 7:	100 resource blocks are allocated in sub-frames 1, 2, 3, 4, 6, 7, 8, 9 and 88 resource blocks (RB0–RB43 and RB56–RB99) are allocated in sub-frame 0.										
Note 8:	24 resource blocks (RB 0-20 and 30-32) are allocated in sub-frames 0, 1, 2, 3, 4, 6, 7, 8, 9										

The reference measurement channels in Table A3.3.3.1-2 apply for verifying demodulation performance for UE-specific reference symbols with two cell specific antenna ports and two CSI-RS antenna ports with ZP CSI-RS and NZP CSI-RS in same subframe.

**Table A.3.3.3.1-2: Fixed Reference Channel for CDM-multiplexed DM RS with two CSI-RS antenna ports with ZP CSI-RS and NZP CSI-RS**

Parameter	Unit	Value				
		R.52 FDD	R.52-1 FDD	R.53 FDD	R.54 FDD	R.97 FDD
Reference channel		R.52 FDD	R.52-1 FDD	R.53 FDD	R.54 FDD	R.97 FDD
Channel bandwidth	MHz	10	10	10	10	10
Allocated resource blocks		50 (Note 3)	50 (Note 3)	50 (Note 3)	50 (Note 3)	50 (Note 3)
Allocated subframes per Radio Frame		9	9	9	9	9
Modulation		64QAM	16QAM	64QAM	16QAM	16QAM
Target Coding Rate		1/2	0.54	1/2	1/2	1/2
Information Bit Payload						
For Sub-Frames 1,3,4,6,8,9	Bits	18336	12960	18336	11448	11448
For Sub-Frames 2,7	Bits	16416	12960	16416	11448	11448
For Sub-Frame 5	Bits	n/a	n/a	n/a	n/a	n/a
For Sub-Frame 0	Bits	14688	10680	14688	9528	9528
Number of Code Blocks (Note 4)						
For Sub-Frames 1,3,4,6,8,9	Code blocks	3	3	3	2	2
For Sub-Frames 2,7	Code blocks	3	3	3	2	2
For Sub-Frame 5	Bits	n/a	n/a	n/a	n/a	n/a
For Sub-Frame 0	Bits	3	2	3	2	2
Binary Channel Bits						
For Sub-Frames 1,3,4,6,8,9	Bits	36000	24000	36000	24000	24000
For Sub-Frames 2,7		34200	22800	33600	22800	22400
For Sub-Frame 5	Bits	n/a	n/a	n/a	n/a	n/a
For Sub-Frame 0	Bits	29520	19680	29520	19680	19680
Max. Throughput averaged over 1 frame	Mbps	15.7536	11.436	15.7536	10.1112	10.1112
Note 1: 2 symbols allocated to PDCCH.						
Note 2: Reference signal, synchronization signals and PBCH allocated as per TS 36.211 [4].						
Note 3: 50 resource blocks are allocated in sub-frames 1, 2, 3, 4, 6, 7, 8, 9 and 41 resource blocks (RB0–RB20 and RB30–RB49) are allocated in sub-frame 0.						
Note 4: If more than one Code Block is present, an additional CRC sequence of L = 24 Bits is attached to each Code Block (otherwise L = 0 Bit).						

**Table A.3.3.3.1-3: Fixed Reference Channel for CDM-multiplexed DM RS with two CSI-RS antenna ports**

Parameter	Unit	Value						
		R.76-1 FDD	R.76-2 FDD	R.76-3 FDD	R.76-4 FDD	R.76-5 FDD	R.76-6 FDD	R.76-7 FDD
Reference channel								
Channel bandwidth	MHz	5	15	20	5	10	15	20
Allocated resource blocks		25 (Note 5)	75 (Note 6)	100 (Note 7)	25 (Note 5)	50 (Note 3)	75 (Note 6)	100 (Note 7)
Allocated subframes per Radio Frame		9	9	9	9	9	9	9
Modulation		QPSK	QPSK	QPSK	QPSK	QPSK	QPSK	QPSK
Target Coding Rate								
Information Bit Payload								
For Sub-Frames 1,4,6,9	Bits	2600	9144	12216	3496	7992	11832	15840
For Sub-Frames 2,3,7,8	Bits	2600	9144	12216	3496	7992	11832	15840
For Sub-Frame 5	Bits	n/a	n/a	n/a	n/a	n/a	n/a	n/a
For Sub-Frame 0	Bits	1736	7736	10680	2344	6456	9912	14112
Number of Code Blocks (Note 4)								
For Sub-Frames 1,4,6,9	Code blocks	1	2	2	1	2	2	3
For Sub-Frames 2,3,7,8	Code blocks	1	2	2	1	2	2	3
For Sub-Frame 5	Bits	n/a	n/a	n/a	n/a	n/a	n/a	n/a
For Sub-Frame 0	Bits	1	2	2	1	2	2	3
Binary Channel Bits								
For Sub-Frames 1,4,6,9	Bits	5400	18000	24000	5400	12000	18000	24000
For Sub-Frames 2,7		5300	17700	23600	5300	11800	17700	23600
For Sub-Frames 3,8		5200	17400	23200	5200	12000	17400	23200
For Sub-Frame 5	Bits	n/a	n/a	n/a	n/a	n/a	n/a	n/a
For Sub-Frame 0	Bits	3456	15120	21120	3456	9840	15120	21120
Max. Throughput averaged over 1 frame	Mbps	2.2536	8.0888	10.8408	3.0312	7.0392	10.4568	14.0832
UE Category		≥ 2	≥ 2	≥ 2	≥ 2	≥ 2	≥ 2	≥ 2
Note 1:	2 symbols allocated to PDCCH for 20 MHz, 15 MHz and 10 MHz channel BW; 3 symbols allocated to PDCCH for 5 MHz and 3 MHz; 4 symbols allocated to PDCCH for 1.4 MHz.							
Note 2:	Reference signal, synchronization signals and PBCH allocated as per TS 36.211 [4].							
Note 3:	50 resource blocks are allocated in sub-frames 1, 2, 3, 4, 6, 7, 8, 9 and 41 resource blocks (RB0–RB20 and RB30–RB49) are allocated in sub-frame 0.							
Note 4:	If more than one Code Block is present, an additional CRC sequence of L = 24 Bits is attached to each Code Block (otherwise L = 0 Bit).							
Note 5:	25 resource blocks are allocated in sub-frames 1, 2, 3, 4, 6, 7, 8, 9 and 17 resource blocks (RB0–RB9 and RB18–RB24) are allocated in sub-frame 0.							
Note 6:	75 resource blocks are allocated in sub-frames 1, 2, 3, 4, 6, 7, 8, 9 and 63 resource blocks (RB0–RB31 and RB44–RB74) are allocated in sub-frame 0.							
Note 7:	100 resource blocks are allocated in sub-frames 1, 2, 3, 4, 6, 7, 8, 9 and 88 resource blocks (RB0–RB43 and RB56–RB99) are allocated in sub-frame 0.							
Note 8:	Given per component carrier per codeword.							

### A.3.3.3.2 Four antenna ports (CSI-RS)

The reference measurement channels in Table A.3.3.3.2-1 apply for verifying demodulation performance for UE-specific reference symbols with two cell-specific antenna ports and four CSI-RS antenna ports.



**Table A.3.3.3.2-1: Fixed Reference Channel for CDM-multiplexed DM RS with four CSI-RS antenna ports**

Parameter	Unit	Value										
		R.43 FDD	R.43-1 FDD	R.43-2 FDD	R.50 FDD	R.48 FDD	R.66 FDD	R.75 FDD	R.75A FDD	R.cc FDD	R.45A-1 FDD	R.102 FDD
Reference channel												
Channel bandwidth	MHz	10	10	10	10	10	10	10	10	10	10	10
Allocated resource blocks		50 (Note 3)	50 (Note 3)	50 (Note 5)	50 (Note 3)	50 (Note 3)	50 (Note 3)	50 (Note 3)	50 (Note 3)	50 (Note 3)	50 (Note 3)	50 (Note 3)
Allocated subframes per Radio Frame		9	9	9	9	9	9	9	9	9	9	9
Modulation		QPSK	QPSK	QPSK	64QAM	QPSK	256QAM	16QAM	16QAM	16QAM	16QAM	1024QAM
Target Coding Rate		1/3	1/3	1/3	1/2		0.77	0.57	0.51	0.64	1/2	3/4
Information Bit Payload												
For Sub-Frames 1,4,6,9	Bits	3624	3624	3624	18336	6200	36696	25456	25456	15264	11448	52752
For Sub-Frames 2,3,7,8	Bits	3624	3624	3624	16416	6200	35160	25456	25456	15264	11448	52752
For Sub-Frame 5	Bits	N/A	N/A	N/A	N/A	N/A	N/A	N/A	N/A	N/A	N/A	N/A
For Sub-Frame 0	Bits	2984	2984	3368	14688	4968	30576	21384	21384	12576	9528	N/A
Number of Code Blocks (Note 4)												
For Sub-Frames 1,4,6,9	Code blocks	1	1	1	3	2	6	5	5	3	2	9
For Sub-Frames 2,3,7,8	Code blocks	1	1	1	3	2	6	5	5	3	2	9
For Sub-Frame 5	Bits	N/A	N/A	N/A	N/A	N/A	N/A	N/A	N/A	N/A	N/A	N/A
For Sub-Frame 0	Bits	1	1	1	3	1	5	4	4	3	2	N/A
Binary Channel Bits												
For Sub-Frames 1,6	Bits	12000	13200	13200	36000	12000	48000	43200	48000	24000	24000	66000
For Sub-Frames 4,9	Bits	12000	12000	12000	36000	12000	48000	43200	48000	24000	24000	66000
For Sub-Frames 2,7	Bits	11600	12800	12800	34800	11600	46400	41600	46400	23200	23200	64000
For Sub-Frames 3,8	Bits	11600	12800	12800	34800	12000	46400	41600	46400	23200	23200	66000
For Sub-Frame 5	Bits	N/A	N/A	N/A	N/A	N/A	N/A	N/A	N/A	N/A	N/A	N/A
For Sub-Frame 0	Bits	9840	9840	10560	29520	9840	39360	35424	40224	19680	19680	N/A
Max. Throughput averaged over 1 frame	Mbps	3.1976	3.1976	3.236	15.3696	5.4568	31.800	22.503	22.503	13.4688	10.1112	46.5832
UE Category		≥ 1	≥ 1	≥ 1	≥ 2	≥ 1	11-12	≥ 5	≥ 5	≥ 2	≥ 2	TBD
UE DL Category		≥ 6	≥ 6	≥ 6	≥ 6	≥ 6	≥ 11	≥ 6	≥ 6	≥ 6	≥ 6	20, ≥ 22

Note 1:	2 symbols allocated to PDCCH. 1 symbol allocated to PDCCH for reference channel with 1024QAM.
Note 2:	Reference signal, synchronization signals and PBCH allocated as per TS 36.211 [4].
Note 3:	50 resource blocks are allocated in sub-frames 1, 2, 3, 4, 6, 7, 8, 9 and 41 resource blocks (RB0–RB20 and RB30–RB49) are allocated in sub-frame 0.
Note 4:	If more than one Code Block is present, an additional CRC sequence of L = 24 Bits is attached to each Code Block (otherwise L = 0 Bit).
Note 5:	50 resource blocks are allocated in sub-frames 1, 2, 3, 4, 6, 7, 8, 9 and 47 resource blocks (RB0–RB23 and RB27–RB49) are allocated in sub-frame 0. In sub-frame 0, PDSCH is rate matched around RB22, RB23 and RB27.

The reference measurement channels in Table A.3.3.3.2-2 apply for verifying FDD PMI accuracy measurement and CRI accuracy measurement with two CRS antenna ports and four CSI-RS antenna ports.

**Table A.3.3.3.2-2: Fixed Reference Channel for four antenna ports (CSI-RS)**

Reference channel	Parameter	Unit						Value
		R.44 FDD	R.45 FDD	R.45-1 FDD	R.60 FDD	R.50A-1 FDD	R.45A-2 FDD	
Channel bandwidth	MHz	10	10	10	10	10	10	
Allocated resource blocks		50 <sup>3</sup>	50 <sup>3</sup>	39	50 <sup>3</sup>	50 <sup>3</sup>	50 <sup>3</sup>	
Allocated subframes per Radio Frame		10	10	10	10	7	10	
Modulation		QPSK	16QAM	16QAM	QPSK	64QAM	16QAM	
Coding Rate		1/3	1/2	1/2	1/2	1/2	1/2	
Modulation Bit Payload								
Sub-Frames (Non CSI-RS subframe)	Bits	3624	11448	8760	6200	18336	11448	
Sub-Frames (CSI-RS subframe)	Bits	3624	11448	8760	6200	N/A	11448	
Resources (ZeroPowerCSI-RS)	Bits	N/A	N/A	N/A	N/A	N/A	N/A	
Sub-Frame 5	Bits	N/A	N/A	N/A	N/A	N/A	N/A	
Sub-Frame 0	Bits	2984	9528	8760	N/A	14688	9528	
Number of Code Blocks per Sub-Frame								
Sub-Frames (Non CSI-RS subframe)		1	2	2	2	3	2	
Sub-Frames (CSI-RS subframe)		1	2	2	2	N/A	2	
Sub-Frames (ZeroPowerCSI-RS subframe)	Bits	N/A	N/A	N/A	N/A	N/A	N/A	
Sub-Frame 5		N/A	N/A	N/A	N/A	N/A	N/A	
Sub-Frame 0		1	2	2	N/A	3	2	
Channel Bits Per Sub-Frame								
Sub-Frames (Non CSI-RS subframe)	Bits	12000	24000	18720	12000	36000	24000	
Sub-Frames (CSI-RS subframe)	Bits	11600	23200	18096	11600	N/A	23600	
Sub-Frames (ZeroPowerCSI-RS subframe)	Bits	N/A	N/A	N/A	N/A	N/A	N/A	
Sub-Frame 5	Bits	N/A	N/A	N/A	N/A	N/A	N/A	
Sub-Frame 0	Bits	9840	19680	18720	N/A	29520	19680	
Throughput averaged over 1 frame	Mbps	3.1976	10.1112	7.884	4.96	12.470	10.111	
Category		≥ 1	≥ 2	≥ 1	≥ 1	≥ 2	≥ 2	

Note 1:	2 symbols allocated to PDCCH for 20 MHz, 15 MHz and 10 MHz channel BW; 3 symbols allocated to PDCCH for 1.4 MHz and 3 MHz; 4 symbols allocated to PDCCH for 1.4 MHz
Note 2:	Reference signal, synchronization signals and PBCH allocated as per TS 36.211 [4]
Note 3:	For R.44, R.45 and R.60, 50 resource blocks are allocated in sub-frames 1,2,3,4,6,7,8,9 and 41 resource blocks (RB0–RB20 and RB30–RB49) are allocated in sub-frame 0. For R.45-1, 39 resource blocks are allocated in sub-frames (RB0–RB20 and RB30–RB47). For R.50A-1, 50 resource blocks are allocated in sub-frames 2, 3 and 41 resource blocks (RB0–RB20 and RB30–RB49) are allocated in sub-frame 0.
Note 4:	If more than one Code Block is present, an additional CRC sequence of L = 24 Bits is attached to each Code Block (otherwise L = 0 Bit)

The reference measurement channels in Table A.3.3.3.2-3 apply for verifying demodulation performance for UE-specific reference symbols with two cell-specific antenna ports and four CSI-RS antenna ports.

**Table A.3.3.3.2-3: Fixed Reference Channel for CDM-multiplexed DM RS with four CSI-RS antenna ports**

Parameter	Unit	Value
Reference channel		R.64 FDD
Channel bandwidth	MHz	10
Allocated resource blocks (Note 4)		6
Allocated subframes per 4 Radio Frames		15
Modulation		QPSK
Target Coding Rate		1/3
Information Bit Payload		
For Sub-Frames 0,1,4,5,6,9 (Note 3)	Bits	504
For Sub-Frames 2,3,7,8 (Note 3)	Bits	504
Number of Code Blocks		
For Sub-Frames 0,1,4,5,6,9	Code blocks	1
For Sub-Frames 2,3,7,8	Code blocks	1
Binary Channel Bits		
For Sub-Frames 0,1,4,5,6,9	Bits	1440
For Sub-Frames 2,3,7,8	Bits	1392
Max. Throughput averaged over 4 frames	Mbps	0.189
UE DL Category		0
Note 1: 2 symbols allocated to PDCCH. Note 2: Reference signal, synchronization signals and PBCH allocated as per TS 36.211 [4]. Note 3: The downlink subframes are scheduled at the 0th, 1st, 2nd, 8th, 9th, 10th, 16th, 17th, 18th, 24th, 25th, 26th, 32nd, 33rd, 34th subframes every 40ms. Information bit payload is available if downlink subframe is scheduled. Note 4: Allocated PRB positions start from {9, 10, ..., 9+N-1}, where N is the number of allocated resource blocks.		

The reference measurement channels in Table A.3.3.3.2-4 apply with two CRS antenna ports and four CSI-RS antenna ports.

Table A.3.3.3.2-4: Fixed Reference Channel for four antenna ports (CSI-RS)

		Parameter	Unit
		R.69 FDD	
	MHz	10	
blocks		50	
blocks per Radio Frame		8	
		QPSK	
2,3,4,6,7,8,9		0.74	
		0.8	
load			
2,3,4,6,7,8,9	Bits	7992	
	Bits	7992	
	Bits	N/A	
	Bits	N/A	
blocks per Sub-Frame			
2,3,4,6,7,8,9		2	
		2	
		N/A	
		N/A	
bits Per Sub-Frame			
2,3,4,6,7,8,9	Bits	10800	
	Bits	10000	
5	Bits	N/A	
	Bits	N/A	
averaged over 1 frame	Mbps	6.3936	
		≥ 1	
		Note 1: 3 symbols allocated to PDCCH.	
		Note 2: Reference signal, synchronization signals and PBCH allocated as per TS 36.	
		Note 3: If more than one Code Block is present, an additional CRC sequence of L = 2 to each Code Block (otherwise L = 0 Bit)	

The reference measurement channels in Table A.3.3.3.2-5 apply with two CRS antenna ports and four CSI-RS antenna ports.

**Table A.3.3.3.2-5: Fixed Reference Channel for CDM-multiplexed DM RS with four CSI-RS antenna ports with ZP CSI-RS and NZP CSI-RS**

Parameter	Unit	Value	
Reference channel		R.98 FDD	R.99 FDD
Channel bandwidth	MHz	10	10
Allocated resource blocks		50 (Note 3)	50 (Note 3)
Allocated subframes per Radio Frame		9	9
Modulation		16QAM	16QAM
Target Coding Rate		1/2	1/2
Information Bit Payload			
For Sub-Frames 1,3,4,6,8,9	Bits	22920	11448
For Sub-Frames 2,7	Bits	22920	11448
For Sub-Frame 5	Bits	n/a	n/a
For Sub-Frame 0	Bits	19080	9528
Number of Code Blocks (Note 4)			
For Sub-Frames 1,3,4,6,8,9	Code blocks	4	2
For Sub-Frames 2, 7	Code blocks	4	2
For Sub-Frame 5	Bits	n/a	n/a
For Sub-Frame 0	Bits	4	2
Binary Channel Bits			
For Sub-Frames 1,3,4,6,8,9	Bits	43200	21600
For Sub-Frames 2,7		38400	19200
For Sub-Frame 5	Bits	n/a	n/a
For Sub-Frame 0	Bits	35424	17712
Max. Throughput averaged over 1 frame	Mbps	20.244	10.1112
Note 1:	2 symbols allocated to PDCCH.		
Note 2:	Reference signal, synchronization signals and PBCH allocated as per TS 36.211 [4].		
Note 3:	50 resource blocks are allocated in sub-frames 1, 2, 3, 4, 6, 7, 8, 9 and 41 resource blocks (RB0–RB20 and RB30–RB49) are allocated in sub-frame 0.		
Note 4:	If more than one Code Block is present, an additional CRC sequence of L = 24 Bits is attached to each Code Block (otherwise L = 0 Bit).		

The reference measurement channels in Table A.3.3.3.2-6 apply with four CRS antenna ports and four CSI-RS antenna ports.

**Table A.3.3.3.2-6: Fixed Reference Channel for CDM-multiplexed DM RS with four CSI-RS antenna ports with ZP CSI-RS and NZP CSI-RS**

Parameter	Unit	Value
Reference channel		R.100 FDD
Channel bandwidth	MHz	10
Allocated resource blocks		50 (Note 3)
Allocated subframes per Radio Frame		9
Modulation		16QAM
Target Coding Rate		1/2
Information Bit Payload		
For Sub-Frames 1,3,4,6,8,9	Bits	22920
For Sub-Frames 2,7	Bits	22920
For Sub-Frame 5	Bits	n/a
For Sub-Frame 0	Bits	19080
Number of Code Blocks (Note 4)		
For Sub-Frames 1,3,4,6,8,9	Code blocks	4
For Sub-Frames 2, 7	Code blocks	4
For Sub-Frame 5	Bits	n/a
For Sub-Frame 0	Bits	4
Binary Channel Bits		
For Sub-Frames 1,3,4,6,8,9	Bits	41600
For Sub-Frames 2,7		36800
For Sub-Frame 5	Bits	n/a
For Sub-Frame 0	Bits	34112
Max. Throughput averaged over 1 frame	Mbps	20.244
Note 1:	2 symbols allocated to PDCCH.	
Note 2:	Reference signal, synchronization signals and PBCH allocated as per TS 36.211 [4].	
Note 3:	50 resource blocks are allocated in sub-frames 1, 2, 3, 4, 6, 7, 8, 9 and 41 resource blocks (RB0–RB20 and RB30–RB49) are allocated in sub-frame 0.	
Note 4:	If more than one Code Block is present, an additional CRC sequence of L = 24 Bits is attached to each Code Block (otherwise L = 0 Bit).	

**A.3.3.3.2A Eight antenna ports (CSI-RS)**

The reference measurement channels in Table A.3.3.3.2A-1 apply for verifying FDD CRI accuracy measurement with two CRS antenna ports and eight CSI-RS antenna ports.

**Table A.3.3.3.2A-1: Fixed Reference Channel for eight antenna ports (CSI-RS)**

Parameter	Unit	Value	
		R.50A-2 FDD	R.50A-3 FDD
Reference channel			
Channel bandwidth	MHz	10	10
Allocated resource blocks		50 <sup>3</sup>	50 <sup>3</sup>
Allocated subframes per Radio Frame		7	5
Modulation		64QAM	64QAM
Target Coding Rate		1/2	1/2
Information Bit Payload			
For Sub-Frames (Non CSI-RS subframe)	Bits	18336	18336
For Sub-Frames (CSI-RS subframe)	Bits	N/A	N/A
For Sub-Frames (ZeroPowerCSI-RS subframe)	Bits	N/A	N/A
For Sub-Frame 5	Bits	N/A	N/A
For Sub-Frame 0	Bits	14688	14688
Number of Code Blocks per Sub-Frame (Note 4)			
For Sub-Frames (Non CSI-RS subframe)		3	3
For Sub-Frames (CSI-RS subframe)		N/A	N/A
For Sub-Frames (ZeroPowerCSI-RS subframe)	Bits	N/A	N/A
For Sub-Frame 5		N/A	N/A
For Sub-Frame 0		3	3
Binary Channel Bits Per Sub-Frame			
For Sub-Frames (Non CSI-RS subframe)	Bits	36000	36000
For Sub-Frames (CSI-RS subframe)	Bits	N/A	N/A
For Sub-Frames (ZeroPowerCSI-RS subframe)	Bits	N/A	N/A
For Sub-Frame 5	Bits	N/A	N/A
For Sub-Frame 0	Bits	29520	29520
Max. Throughput averaged over 1 frame	Mbps	12.4704	8.8032
UE Category		≥ 2	≥ 2
Note 1:	2 symbols allocated to PDCCH for 20 MHz, 15 MHz and 10 MHz channel BW; 3 symbols allocated to PDCCH for 5 MHz and 3 MHz; 4 symbols allocated to PDCCH for 1.4 MHz		
Note 2:	Reference signal, synchronization signals and PBCH allocated as per TS 36.211 [4]		
Note 3:	For R.50A-2, 50 resource blocks are allocated in sub-frames 2, 3, 4, 7, 8, 9 and 41 resource blocks (RB0–RB20 and RB30–RB49) are allocated in sub-frame 0. For R.50A-3, 50 resource blocks are allocated in sub-frames 3, 4, 8, 9 and 41 resource blocks (RB0–RB20 and RB30–RB49) are allocated in sub-frame 0.		
Note 4:	If more than one Code Block is present, an additional CRC sequence of L = 24 Bits is attached to each Code Block (otherwise L = 0 Bit)		

**Table A.3.3.3.2A-2: Fixed Reference Channel for eight antenna ports (CSI-RS)**



Parameter	Unit	Value
Reference channel		R.108 FDD
Channel bandwidth	MHz	10
Allocated resource blocks		4 <sup>3</sup>
Allocated subframes per Radio Frame		8
Modulation		QPSK
Target Coding Rate		1/2
Information Bit Payload		
For Sub-Frames (Non CSI-RS subframe)	Bits	472
For Sub-Frames (CSI-RS subframe)	Bits	472
For Sub-Frame 5,7	Bits	N/A
Number of Code Blocks per Sub-Frame (Note 4)		
For Sub-Frames (Non CSI-RS subframe)		1
For Sub-Frames (CSI-RS subframe)		1
For Sub-Frame 5,7		N/A
Binary Channel Bits Per Sub-Frame		
For Sub-Frames (Non CSI-RS subframe)	Bits	960
For Sub-Frames (CSI-RS subframe)	Bits	896
For Sub-Frame 5,7	Bits	N/A
Max. Throughput averaged over 1 frame	Mbps	0.3776
UE Category		≥ 1
Note 1:	2 symbols allocated to PDCCH.	
Note 2:	Reference signal, synchronization signals and PBCH allocated as per TS 36.211 [4]	
Note 3:	Allocated PRB positions for PDSCH are {2, 3, 4, 5} within the assigned narrowband. Allocated PRB positions for MPDCCH are {0, 1} within the assigned narrowband.	
Note 4:	If more than one Code Block is present, an additional CRC sequence of L = 24 Bits is attached to each Code Block (otherwise L = 0 Bit)	

#### A.3.3.3.3 Twelve antenna port (CSI-RS)

The reference measurement channels in Table A.3.3.3.3-1 apply for verifying PMI accuracy performance for UE-specific reference symbols with two cell-specific antenna ports and twelve CSI-RS antenna ports.

**Table A.3.3.3.3-1: Fixed Reference Channel for CDM-multiplexed DM RS with twelve CSI-RS antenna ports**

Parameter	Unit	Value
Reference channel		R.77 FDD
Channel bandwidth	MHz	10
Allocated resource blocks		50 (Note 3)
Allocated subframes per Radio Frame		9
Modulation		64QAM
Target Coding Rate		1/2
<b>Information Bit Payload</b>		
For Sub-Frames (Non CSI-RS subframe)	Bits	18336
For Sub-Frames (CSI-RS subframe)	Bits	16416
For Sub-Frames (ZeroPowerCSI-RS subframe)	Bits	N/A
For Sub-Frame 5	Bits	N/A
For Sub-Frame 0		14688
<b>Number of Code Blocks per Sub-Frame</b>		
For Sub-Frames (Non CSI-RS subframe)	Code blocks	3
For Sub-Frames (CSI-RS subframe)	Bits	3
For Sub-Frames (ZeroPowerCSI-RS subframe)	Bits	N/A
For Sub-Frame 5		N/A
For Sub-Frame 0	Bits	3
<b>Binary Channel Bits Per Sub-Frame</b>		
For Sub-Frames (Non CSI-RS subframe)		36000
For Sub-Frames (CSI-RS subframe)	Bits	32400
For Sub-Frames (ZeroPowerCSI-RS subframe)	Bits	N/A
For Sub-Frame 5	Bits	N/A
For Sub-Frame 0	Bits	29520
Max. Throughput averaged over 1 frame	Mbps	15.7536
UE Category		$\geq 2$
Note 1: 2 symbols allocated to PDCCH.		
Note 2: Reference signal, synchronization signals and PBCH allocated as per TS 36.211 [4].		
Note 3: 50 resource blocks are allocated in sub-frames 1, 2, 3, 4, 6, 7, 8, 9 and 41 resource blocks (RB0–RB20 and RB30–RB49) are allocated in sub-frame 0.		
Note 4: If more than one Code Block is present, an additional CRC sequence of L = 24 Bits is attached to each Code Block (otherwise L = 0 Bit).		

**A.3.3.3.4 Sixteen antenna port (CSI-RS)**

The reference measurement channels in Table A.3.3.3.4-1 apply for verifying PMI accuracy performance for UE-specific reference symbols with two cell-specific antenna ports and sixteen CSI-RS antenna ports.

**Table A.3.3.3.4-1: Fixed Reference Channel for CDM-multiplexed DM RS with sixteen CSI-RS antenna ports**

Parameter	Unit	Value
-----------	------	-------

Reference channel		R.78 FDD
Channel bandwidth	MHz	10
Allocated resource blocks		50 (Note 3)
Allocated subframes per Radio Frame		9
Modulation		16QAM
Target Coding Rate		1/2
Information Bit Payload		
For Sub-Frames (Non CSI-RS subframe)	Bits	11448
For Sub-Frames (CSI-RS subframe)	Bits	9912
For Sub-Frames (ZeroPowerCSI-RS subframe)	Bits	N/A
For Sub-Frame 5	Bits	N/A
For Sub-Frame 0		9528
Number of Code Blocks per Sub-Frame	Code blocks	
For Sub-Frames (Non CSI-RS subframe)	Code blocks	2
For Sub-Frames (CSI-RS subframe)	Bits	2
For Sub-Frames (ZeroPowerCSI-RS subframe)	Bits	N/A
For Sub-Frame 5		N/A
For Sub-Frame 0	Bits	2
Binary Channel Bits Per Sub-Frame		
For Sub-Frames (Non CSI-RS subframe)		24000
For Sub-Frames (CSI-RS subframe)	Bits	20800
For Sub-Frames (ZeroPowerCSI-RS subframe)	Bits	N/A
For Sub-Frame 5	Bits	N/A
For Sub-Frame 0	Bits	19680
Max. Throughput averaged over 1 frame	Mbps	9.804
UE Category		$\geq 2$
Note 1:	2 symbols allocated to PDCCH.	
Note 2:	Reference signal, synchronization signals and PBCH allocated as per TS 36.211 [4].	
Note 3:	50 resource blocks are allocated in sub-frames 1, 2, 3, 4, 6, 7, 8, 9 and 41 resource blocks (RB0–RB20 and RB30–RB49) are allocated in sub-frame 0.	
Note 4:	If more than one Code Block is present, an additional CRC sequence of L = 24 Bits is attached to each Code Block (otherwise L = 0 Bit).	

#### A.3.3.3.5 Twenty-four antenna port (CSI-RS)

The reference measurement channels in Table A.3.3.3.5-1 apply for verifying PMI accuracy performance for UE-specific reference symbols with two cell-specific antenna ports and twenty-four CSI-RS antenna ports.

**Table A.3.3.3.5-1: Fixed Reference Channel for CDM-multiplexed DM RS with twenty-four CSI-RS antenna ports**

Parameter	Unit	Value	
Reference channel		R.88 FDD	R.88A FDD
Channel bandwidth	MHz	10	10
Allocated resource blocks		50 (Note 3)	50 (Note 3)
Allocated subframes per Radio Frame		9	9
Modulation		16QAM	16QAM
Target Coding Rate		1/2	1/2
Information Bit Payload			
For Sub-Frames (Non CSI-RS subframe)	Bits	11448	11448
For Sub-Frames (CSI-RS subframe)	Bits	9912	11448
For Sub-Frames (ZeroPowerCSI-RS subframe)	Bits	N/A	N/A
For Sub-Frame 5	Bits	N/A	N/A
For Sub-Frame 0		9528	9528
Number of Code Blocks per Sub-Frame	Code blocks		
For Sub-Frames (Non CSI-RS subframe)	Code blocks	2	2
For Sub-Frames (CSI-RS subframe)	Bits	2	2
For Sub-Frames (ZeroPowerCSI-RS subframe)	Bits	N/A	N/A
For Sub-Frame 5		N/A	N/A
For Sub-Frame 0	Bits	2	2
Binary Channel Bits Per Sub-Frame			
For Sub-Frames (Non CSI-RS subframe)		24000	24000
For Sub-Frames (CSI-RS subframe)	Bits	19200	22400
For Sub-Frames (ZeroPowerCSI-RS subframe)	Bits	N/A	N/A
For Sub-Frame 5	Bits	N/A	N/A
For Sub-Frame 0	Bits	19680	19680
Max. Throughput averaged over 1 frame	Mbps	9.804	10.1112
UE Category		≥ 2	≥ 2
Note 1:	2 symbols allocated to PDCCH.		
Note 2:	Reference signal, synchronization signals and PBCH allocated as per TS 36.211 [4].		
Note 3:	50 resource blocks are allocated in sub-frames 1, 2, 3, 4, 6, 7, 8, 9 and 41 resource blocks (RB0–RB20 and RB30–RB49) are allocated in sub-frame 0.		
Note 4:	If more than one Code Block is present, an additional CRC sequence of L = 24 Bits is attached to each Code Block (otherwise L = 0 Bit).		

### A.3.3.3.6 Thirty-two antenna port (CSI-RS)

The reference measurement channels in Table A.3.3.3.6-1 apply for verifying PMI accuracy performance for UE-specific reference symbols with two cell-specific antenna ports and thirty-two CSI-RS antenna ports.

**Table A.3.3.3.6-1: Fixed Reference Channel for CDM-multiplexed DM RS with thirty-two CSI-RS antenna ports**

Parameter	Unit	Value
Reference channel		R.89 FDD
Channel bandwidth	MHz	10
Allocated resource blocks		50 (Note 3)
Allocated subframes per Radio Frame		9
Modulation		64QAM
Target Coding Rate		1/2
<b>Information Bit Payload</b>		
For Sub-Frames (Non CSI-RS subframe)	Bits	18336
For Sub-Frames (CSI-RS subframe)	Bits	15264
For Sub-Frames (ZeroPowerCSI-RS subframe)	Bits	N/A
For Sub-Frame 5	Bits	N/A
For Sub-Frame 0		14688
<b>Number of Code Blocks per Sub-Frame</b>		
For Sub-Frames (Non CSI-RS subframe)	Code blocks	3
For Sub-Frames (CSI-RS subframe)	Bits	3
For Sub-Frames (ZeroPowerCSI-RS subframe)	Bits	N/A
For Sub-Frame 5		N/A
For Sub-Frame 0	Bits	3
<b>Binary Channel Bits Per Sub-Frame</b>		
For Sub-Frames (Non CSI-RS subframe)		36000
For Sub-Frames (CSI-RS subframe)	Bits	26400
For Sub-Frames (ZeroPowerCSI-RS subframe)	Bits	N/A
For Sub-Frame 5	Bits	N/A
For Sub-Frame 0	Bits	29520
Max. Throughput averaged over 1 frame	Mbps	15.5232
UE Category		$\geq 2$
<p>Note 1: 2 symbols allocated to PDCCH.</p> <p>Note 2: Reference signal, synchronization signals and PBCH allocated as per TS 36.211 [4].</p> <p>Note 3: 50 resource blocks are allocated in sub-frames 1, 2, 3, 4, 6, 7, 8, 9 and 41 resource blocks (RB0–RB20 and RB30–RB49) are allocated in sub-frame 0.</p> <p>Note 4: If more than one Code Block is present, an additional CRC sequence of L = 24 Bits is attached to each Code Block (otherwise L = 0 Bit).</p>		

## A.3.4 Reference measurement channels for PDSCH performance requirements (TDD)

### A.3.4.1 Single-antenna transmission (Common Reference Symbols)

**Table A.3.4.1-1: Fixed Reference Channel QPSK R=1/3**

Parameter	Unit	Value						
		R.4 TDD	R.42 TDD	R.2A TDD	R.2 TDD	R.42-1 TDD	R.42-2 TDD	R.42-3 TDD
Reference channel								
Channel bandwidth	MHz	1.4	20	10	10	3	5	15
Allocated resource blocks (Note 6)		6	100	50	50	15	25	75
Uplink-Downlink Configuration (Note 4)		1	1	2	1	1	1	1
Allocated subframes per Radio Frame (D+S)		3	3+2	5+2	3+2	3+2	3+2	3+2
Modulation		QPSK	QPSK	QPSK	QPSK	QPSK	QPSK	QPSK
Target Coding Rate		1/3	1/3	1/3	1/3	1/3	1/3	1/3
Information Bit Payload (Note 6)								
For Sub-Frames 4,9	Bits	408	8760	4392	4392	1320	2216	6712
For Sub-Frames 1,6	Bits	N/A	7736	3240	3240	1128	1864	5992
For Sub-Frames 3,8	Bits	N/A	N/A	4392	N/A	N/A	N/A	N/A
For Sub-Frame 5	Bits	N/A	N/A	N/A	N/A	N/A	N/A	N/A
For Sub-Frame 0	Bits	208	8760	4392	4392	1064	1800	6712
Number of Code Blocks (Notes 5 and 6)								
For Sub-Frames 4,9		1	2	1	1	1	1	2
For Sub-Frames 1,6		N/A	2	1	1	1	1	1
For Sub-Frames 3,8		N/A	N/A	1	N/A	N/A	N/A	N/A
For Sub-Frame 5		N/A	N/A	N/A	N/A	N/A	N/A	N/A
For Sub-Frame 0		1	2	1	1	1	1	2
Binary Channel Bits (Note 6)								
For Sub-Frames 4,9	Bits	1368	27600	13800	13800	3780	6300	20700
For Sub-Frames 1,6	Bits	N/A	22656	11256	11256	3276	5556	16956
For Sub-Frames 3,8		N/A	N/A	13800	N/A	N/A	N/A	N/A
For Sub-Frame 5	Bits	N/A	N/A	N/A	N/A	N/A	N/A	N/A
For Sub-Frame 0	Bits	672	26904	13104	13104	3084	5604	20004
Max. Throughput averaged over 1 frame (Note 6)	Mbps	0.102	4.175	2.844	1.966	0.596	0.996	3.212
UE Category		≥ 1	≥ 1	≥ 1	≥ 1	≥ 1	≥ 1	≥ 1
Note 1:	2 symbols allocated to PDCCH for 20 MHz, 15 MHz and 10 MHz channel BW; 3 symbols allocated to PDCCH for 5 MHz and 3 MHz; 4 symbols allocated to PDCCH for 1.4 MHz. For subframe 1&6, only 2 OFDM symbols are allocated to PDCCH.							
Note 2:	For BW=1.4 MHz, the information bit payloads of special subframes are set to zero (no scheduling) to avoid problems with insufficient PDCCH performance at the test point.							
Note 3:	Reference signal, synchronization signals and PBCH allocated as per TS 36.211 [4].							
Note 4:	As per Table 4.2-2 in TS 36.211 [4].							
Note 5:	If more than one Code Block is present, an additional CRC sequence of L = 24 Bits is attached to each Code Block (otherwise L = 0 Bit).							
Note 6:	Given per component carrier per codeword.							

Table A.3.4.1-2: Fixed Reference Channel 16QAM R=1/2

Parameter	Unit	Value					
				R.3-1 TDD	R.3 TDD		
Reference channel							
Channel bandwidth	MHz	1.4	3	5	10	15	20
Allocated resource blocks				25	50		
Uplink-Downlink Configuration (Note 3)				1	1		
Allocated subframes per Radio Frame (D+S)				3+2	3+2		
Modulation				16QAM	16QAM		
Target Coding Rate				1/2	1/2		
Information Bit Payload							
For Sub-Frames 4,9	Bits			6456	14112		
For Sub-Frames 1,6	Bits			5160	11448		
For Sub-Frame 5	Bits			N/A	N/A		
For Sub-Frame 0	Bits			5736	12960		
Number of Code Blocks per Sub-Frame (Note 4)							
For Sub-Frames 4,9				2	3		
For Sub-Frames 1,6				1	2		
For Sub-Frame 5				N/A	N/A		
For Sub-Frame 0				1	3		
Binary Channel Bits Per Sub-Frame							
For Sub-Frames 4,9	Bits			12600	27600		
For Sub-Frames 1,6	Bits			11112	22512		
For Sub-Frame 5	Bits			N/A	N/A		
For Sub-Frame 0	Bits			11208	26208		
Max. Throughput averaged over 1 frame	Mbps			2.897	6.408		
UE Category				≥ 1	≥ 2		
Note 1:	2 symbols allocated to PDCCH for 20 MHz, 15 MHz and 10 MHz channel BW; 3 symbols allocated to PDCCH for 5 MHz and 3 MHz; 4 symbols allocated to PDCCH for 1.4 MHz. For subframe 1&6, only 2 OFDM symbols are allocated to PDCCH.						
Note 2:	Reference signal, synchronization signals and PBCH allocated as per TS 36.211 [4]						
Note 3:	As per Table 4.2-2 in TS 36.211 [4].						
Note 4:	If more than one Code Block is present, an additional CRC sequence of L = 24 Bits is attached to each Code Block (otherwise L = 0 Bit).						

Table A.3.4.1-3: Fixed Reference Channel 64QAM R=3/4

Parameter	Unit	Value					
		R.5 TDD	R.6 TDD	R.7 TDD	R.8 TDD	R.9 TDD	
Reference channel							
Channel bandwidth	MHz	1.4	3	5	10	15	20
Allocated resource blocks			15	25	50	75	100
Uplink-Downlink Configuration (Note 3)			1	1	1	1	1
Allocated subframes per Radio Frame (D+S)			3+2	3+2	3+2	3+2	3+2
Modulation		64QAM	64QAM	64QAM	64QAM	64QAM	64QAM
Target Coding Rate			3/4	3/4	3/4	3/4	3/4
Information Bit Payload							
For Sub-Frames 4,9	Bits		8504	14112	30576	46888	61664
For Sub-Frames 1,6	Bits		6968	11448	23688	35160	46888
For Sub-Frame 5	Bits		N/A	N/A	N/A	N/A	N/A
For Sub-Frame 0	Bits		6968	12576	30576	45352	61664
Number of Code Blocks per Sub-Frame (Note 4)							
For Sub-Frames 4,9			2	3	5	8	11
For Sub-Frames 1,6			2	2	4	6	8
For Sub-Frame 5			N/A	N/A	N/A	N/A	N/A
For Sub-Frame 0			2	3	5	8	11
Binary Channel Bits Per Sub-Frame							
For Sub-Frames 4,9	Bits		11340	18900	41400	62100	82800
For Sub-Frames 1,6	Bits		9828	16668	33768	50868	67968
For Sub-Frame 5	Bits		N/A	N/A	N/A	N/A	N/A
For Sub-Frame 0	Bits		9252	16812	39312	60012	80712
Max. Throughput averaged over 1 frame	Mbps		3.791	6.370	13.910	20.945	27.877
UE Category			≥ 1	≥ 2	≥ 2	≥ 2	≥ 3
Note 1:	2 symbols allocated to PDCCH for 20 MHz, 15 MHz and 10 MHz channel BW; 3 symbols allocated to PDCCH for 5 MHz and 3 MHz; 4 symbols allocated to PDCCH for 1.4 MHz. For subframe 1&6, only 2 OFDM symbols are allocated to PDCCH.						
Note 2:	Reference signal, synchronization signals and PBCH allocated as per TS 36.211 [4]						
Note 3:	As per Table 4.2-2 TS 36.211 [4].						
Note 4:	If more than one Code Block is present, an additional CRC sequence of L = 24 Bits is attached to each Code Block (otherwise L = 0 Bit).						



Table A.3.4.1-3a: Fixed Reference Channel 64QAM R=3/4

Parameter	Unit	Value				
		R.6-1 TDD	R.7-1 TDD	R.8-1 TDD	R.9-1 TDD	R.9-2 TDD
Reference channel						
Channel bandwidth	MHz	5	10	15	20	20
Allocated resource blocks (Note 3)		18	17	17	17	83
Uplink-Downlink Configuration (Note 4)		1	1	1	1	1
Allocated subframes per Radio Frame (D+S)		3+2	3+2	3+2	3+2	3+2
Modulation		64QAM	64QAM	64QAM	64QAM	64QAM
Target Coding Rate		3/4	3/4	3/4	3/4	3/4
Information Bit Payload						
For Sub-Frames 4,9	Bits	10296	10296	10296	10296	51024
For Sub-Frames 1,6	Bits	8248	7480	7480	7480	39232
For Sub-Frame 5	Bits	N/A	N/A	N/A	N/A	N/A
For Sub-Frame 0	Bits	8248	10296	10296	10296	51024
Number of Code Blocks per Sub-Frame (Note 5)						
For Sub-Frames 4,9		2	2	2	2	9
For Sub-Frames 1,6		2	2	2	2	7
For Sub-Frame 5		N/A	N/A	N/A	N/A	N/A
For Sub-Frame 0		2	2	2	2	9
Binary Channel Bits Per Sub-Frame						
For Sub-Frames 4,9	Bits	13608	14076	14076	14076	68724
For Sub-Frames 1,6	Bits	11880	11628	11628	11628	56340
For Sub-Frame 5	Bits	N/A	N/A	N/A	N/A	N/A
For Sub-Frame 0	Bits	11520	14076	14076	14076	66636
Max. Throughput averaged over 1 frame	Mbps	4.534	4.585	4.585	4.585	23.154
UE Category		≥ 1	≥ 1	≥ 1	≥ 1	≥ 2
Note 1:	2 symbols allocated to PDCCH for 20 MHz, 15 MHz and 10 MHz channel BW; 3 symbols allocated to PDCCH for 5 MHz and 3 MHz; 4 symbols allocated to PDCCH for 1.4 MHz. For subframe 1&6, only 2 OFDM symbols are allocated to PDCCH.					
Note 2:	Reference signal, synchronization signals and PBCH allocated as per TS 36.211 [4]					
Note 3:	Localized allocation started from RB #0 is applied.					
Note 4:	As per Table 4.2-2 TS 36.211 [4].					
Note 5:	If more than one Code Block is present, an additional CRC sequence of L = 24 Bits is attached to each Code Block (otherwise L = 0 Bit).					

Table A.3.4.1-4: Fixed Reference Channel Single PRB

Parameter	Unit	Value					
			R.0 TDD		R.1 TDD		
Reference channel							
Channel bandwidth	MHz	1.4	3	5	10/20	15	20
Allocated resource blocks			1		1		
Uplink-Downlink Configuration (Note 3)			1		1		
Allocated subframes per Radio Frame (D+S)			3+2		3+2		
Modulation			16QAM		16QAM		
Target Coding Rate			1/2		1/2		
Information Bit Payload							
For Sub-Frames 4,9	Bits		224		256		
For Sub-Frames 1,6	Bits		208		208		
For Sub-Frame 5	Bits		N/A		N/A		
For Sub-Frame 0	Bits		224		256		
Number of Code Blocks per Sub-Frame (Note 4)							
For Sub-Frames 4,9			1		1		
For Sub-Frames 1,6			1		1		
For Sub-Frame 5			N/A		N/A		
For Sub-Frame 0			1		1		
Binary Channel Bits Per Sub-Frame							
For Sub-Frames 4,9	Bits		504		552		
For Sub-Frames 1,6	Bits		456		456		
For Sub-Frame 5	Bits		N/A		N/A		
For Sub-Frame 0	Bits		504		552		
Max. Throughput averaged over 1 frame	Mbps		0.109		0.118		
UE Category			≥ 1		≥ 1		
Note 1:	2 symbols allocated to PDCCH for 20 MHz, 15 MHz and 10 MHz channel BW; 3 symbols allocated to PDCCH for 5 MHz and 3 MHz; 4 symbols allocated to PDCCH for 1.4 MHz. For subframe 1&6, only 2 OFDM symbols are allocated to PDCCH.						
Note 2:	Reference signal, synchronization signals and PBCH allocated as per TS 36.211 [4]						
Note 3:	As per Table 4.2-2 in TS 36.211 [4].						
Note 4:	If more than one Code Block is present, an additional CRC sequence of L = 24 Bits is attached to each Code Block (otherwise L = 0 Bit).						

Table A.3.4.1-5: Fixed Reference Channel Single PRB (MBSFN Configuration)

Parameter	Unit	Value
Reference channel		R.29 TDD (MBSFN)
Channel bandwidth	MHz	10
Allocated resource blocks		1
MBSFN Configuration (Note 5)		010010
Uplink-Downlink Configuration (Note 3)		1
Allocated subframes per Radio Frame (D+S)		1+2
Modulation		16QAM
Target Coding Rate		1/2
Information Bit Payload		
For Sub-Frames 4,9	Bits	0 (MBSFN)
For Sub-Frames 1,6	Bits	208
For Sub-Frame 5	Bits	N/A
For Sub-Frame 0	Bits	256
Number of Code Blocks per Sub-Frame (Note 4)		
For Sub-Frames 4,9	Bits	0 (MBSFN)
For Sub-Frames 1,6	Bits	1
For Sub-Frame 5	Bits	N/A
For Sub-Frame 0	Bits	1
Binary Channel Bits Per Sub-Frame		
For Sub-Frames 4,9	Bits	0 (MBSFN)
For Sub-Frames 1,6	Bits	456
For Sub-Frame 5	Bits	N/A
For Sub-Frame 0	Bits	552
Max. Throughput averaged over 1 frame	kbps	67.2
UE Category		≥ 1
Note 1:	2 symbols allocated to PDCCH.	
Note 2:	Reference signal, synchronization signals and PBCH allocated as per TS 36.211 [4].	
Note 3:	as per Table 4.2-2 in TS 36.211 [4].	
Note 4:	If more than one Code Block is present, an additional CRC sequence of L = 24 Bits is attached to each Code Block (otherwise L = 0 Bit).	
Note 5:	MBSFN Subframe Allocation as defined in [7], one frame with 6 bits is chosen for MBSFN subframe allocation	

Table A.3.4.1-6: Fixed Reference Channel QPSK R=1/10

Parameter	Unit	Value					
		1.4	3	5	R.41 TDD	15	20
Reference channel							
Channel bandwidth	MHz	1.4	3	5	10	15	20
Allocated resource blocks					50		
Uplink-Downlink Configuration (Note 4)					1		
Allocated subframes per Radio Frame (D+S)					3+2		
Modulation					QPSK		
Target Coding Rate					1/10		
Information Bit Payload							
For Sub-Frames 4,9	Bits				1384		
For Sub-Frames 1,6	Bits				1032		
For Sub-Frame 5	Bits				N/A		
For Sub-Frame 0	Bits				1384		
Number of Code Blocks per Sub-Frame (Note 5)							
For Sub-Frames 4,9					1		
For Sub-Frames 1,6					1		
For Sub-Frame 5					N/A		
For Sub-Frame 0					1		
Binary Channel Bits Per Sub-Frame							
For Sub-Frames 4,9	Bits				13800		
For Sub-Frames 1,6	Bits				11256		
For Sub-Frame 5	Bits				N/A		
For Sub-Frame 0	Bits				13104		
Max. Throughput averaged over 1 frame	Mbps				0.622		
UE Category					≥ 1		
Note 1:	2 symbols allocated to PDCCH for 20 MHz, 15 MHz and 10 MHz channel BW; 3 symbols allocated to PDCCH for 5 MHz and 3 MHz; 4 symbols allocated to PDCCH for 1.4 MHz. For subframe 1&6, only 2 OFDM symbols are allocated to PDCCH.						
Note 2:	For BW=1.4 MHz, the information bit payloads of special subframes are set to zero (no scheduling) to avoid problems with insufficient PDCCH performance at the test point.						
Note 3:	Reference signal, synchronization signals and PBCH allocated as per TS 36.211 [4]						
Note 4:	As per Table 4.2-2 in TS 36.211 [4].						
Note 5:	If more than one Code Block is present, an additional CRC sequence of L = 24 Bits is attached to each Code Block (otherwise L = 0 Bit).						

Table A.3.4.1-7: Fixed Reference Channel for CA demodulation with power imbalance

Parameter	Unit	Value	
		R.49 TDD	R.49-1 TDD
Reference channel		R.49 TDD	R.49-1 TDD
Channel bandwidth	MHz	20	15
Allocated resource blocks		100	75
Uplink-Downlink Configuration (Note 1)		1	1
Allocated subframes per Radio Frame (D+S)		3+2	3+2
Modulation		64QAM	64QAM
Number of OFDM symbols for PDCCH per component carrier			
For Sub-Frames 0,4,5,9	OFDM symbols	3	3
For Sub-Frames 1,6	OFDM symbols	2	2
Target Coding Rate			
For Sub-Frames 4,9		0.84	0.83
For Sub-Frames 1,6		0.81	0.80
For Sub-Frames 5		N/A	N/A
For Sub-Frames 0		0.87	0.86
Information Bit Payload			
For Sub-Frames 0, 4, 9	Bits	63776	46888
For Sub-Frame 1,6	Bits	55056	40576
For Sub-Frame 5	Bits	N/A	N/A
Number of Code Blocks per Sub-Frame (Note 2)			
For Sub-Frames 0, 4, 9	Code Blocks	11	8
For Sub-Frame 1,6	Code Blocks	9	7
For Sub-Frame 5	Code Blocks	N/A	N/A
Binary Channel Bits Per Sub-Frame			
For Sub-Frames 4,9	Bits	75600	56700
For Sub-Frame 1,6	Bits	67968	50868
For Sub-Frame 5	Bits	N/A	N/A
For Sub-Frame 0	Bits	73512	54612
Max. Throughput averaged over 1 frame	Mbps	30.144	22.182
UE Category		≥5	≥3
Note 1:	Reference signal, synchronization signals and PBC allocated as per TS 36.211 [4].		
Note 2:	If more than one Code Block is present, an additional CRC sequence of L = 24 Bits is attached to each Code Block (otherwise L = 0 Bit).		

## A.3.4.2 Multi-antenna transmission (Common Reference Signals)

## A.3.4.2.1 Two antenna ports

Table A.3.4.2.1-1: Fixed Reference Channel two antenna ports

Parameter	Unit						Value					
		R.10 TDD	R.11 TDD	R.11-1 TDD	R.11-2 TDD	R.11-3 TDD Note 6	R.11-4 TDD	R.30 TDD	R.30-1 TDD	R.30-2 TDD	R.35 TDD	R.35-1 TDD
Reference channel												
Channel bandwidth	MHz	10	10	10	5	10	10	20	20	20	10	20
Allocated resource blocks (Note 5)		50	50	50	25	40	50	100	100	100	50	100
Uplink-Downlink Configuration (Note 3)		1	1	1	1	1	1	1	1	1	1	1
Allocated subframes per Radio Frame (D+S)		3+2	3+2	2+2	3+2	3+2	2	3+2	2+2	2	2+2	2
Modulation		QPSK	16QAM	16QAM	16QAM	16QAM	QPSK	16QAM	16QAM	16QAM	64QAM	64QAM
Target Coding Rate		1/3	1/2	1/2	1/2	1/2	1/2	1/2	1/2	1/2	1/2	0.39
Information Bit Payload (Note 5)												
For Sub-Frames 4,9	Bits	4392	12960	12960	5736	10296	6968	25456	25456	25456	19848	30576
For Sub-Frames 1,6		3240	9528	9528	5160	9144	N/A	22920	21384	N/A	15840	N/A
For Sub-Frame 5	Bits	N/A	N/A	N/A	N/A	N/A	N/A	N/A	N/A	N/A	N/A	N/A
For Sub-Frame 0	Bits	4392	12960	N/A	4968	10296	N/A	25456	N/A	N/A	N/A	N/A
Number of Code Blocks (Notes 4 and 5)												
For Sub-Frames 4,9		1	3	3	1	2	2	5	5	5	4	5
For Sub-Frames 1,6		1	2	2	1	2	N/A	4	4	N/A	3	N/A
For Sub-Frame 5		N/A	N/A	N/A	N/A	N/A	N/A	N/A	N/A	N/A	N/A	N/A
For Sub-Frame 0		1	3	N/A	1	2	N/A	5	N/A	N/A	N/A	N/A
Binary Channel Bits (Note 5)												
For Sub-Frames 4,9	Bits	13200	26400	26400	12000	21120	13200	52800	52800	52800	39600	79200

For Sub-Frames 1,6		10656	21312	21312	10512	16992	10656	42912	42912	N/A	31968	N/A
For Sub-Frame 5	Bits	N/A	N/A	N/A	N/A	N/A	N/A	N/A	N/A	N/A	N/A	N/A
For Sub-Frame 0	Bits	12528	25056	N/A	10656	19776	12528	51456	N/A	N/A	N/A	N/A
Max. Throughput averaged over 1 frame (Note 5)	Mbps	1.966	5.794	4.498	2.676	4.918	1.39	12.221	9.368	5.091	7.138	6.115
UE Category		$\geq 1$	$\geq 2$	$\geq 2$	$\geq 1$	$\geq 1$	$\geq 1$	$\geq 2$	$\geq 2$	3	$\geq 2$	4
<p>Note 1: 2 symbols allocated to PDCCH for 20 MHz, 15 MHz and 10 MHz channel BW; 3 symbols allocated to PDCCH for 5 MHz and 3 MHz; 4 symbols allocated to PDCCH for 1.4 MHz. For subframe 1&amp;6, only 2 OFDM symbols are allocated to PDCCH.</p> <p>Note 2: Reference signal, synchronization signals and PBCH allocated as per TS 36.211 [4].</p> <p>Note 3: As per Table 4.2-2 in TS 36.211 [4].</p> <p>Note 4: If more than one Code Block is present, an additional CRC sequence of L = 24 Bits is attached to each Code Block (otherwise L = 0 Bit).</p> <p>Note 5: Given per component carrier per codeword.</p> <p>Note 6: For R.11-3 resource blocks of RB6–RB45 are allocated.</p>												

Table A.3.4.2.1-2: Fixed Reference Channel two antenna ports

Parameter	Unit	Value											
		R.46 TDD	R.47 TDD	R.35-2 TDD	R.11-5 TDD	R.11-6 TDD	R.11-7 TDD	R.11-8 TDD	R.11-9 TDD	R.11-10 TDD	R.11-11 TDD	R.11-12 TDD	R.10-3 TDD
Reference channel													
Channel bandwidth	MHz	10	10	10	1.4	3	5	10	15	10	10	10	10
Allocated resource blocks (Note 5)		50	50	50	6	15	25	50	75	50	50	50	50
Uplink-Downlink Configuration (Note 3)		1	1	1	1	1	1	1	1	1	1	1	1
Allocated number of PDCCH symbols in normal subframes		2	2	2	4	3	3	2	2	2	3	3	2
Allocated number of PDCCH symbols in special subframes		2	2	2	2	2	2	2	2	2	2	2	2
Allocated subframes per Radio Frame (D+S)		3+2	3+2	2+2	2+2	2+2	2+2	2+2	2+2	3+2	2+2	2+2	3+2
Modulation		QPSK	16QAM	64QAM	16QAM	16QAM	16QAM	16QAM	16QAM	QPSK	QPSK	QPSK	16QAM
Target Coding Rate				0.47	1/2	1/2	1/2	1/2	1/2	3/5			
For Sub-Frames 4,9											0.58	0.66	0.58
For Sub-Frames 1,6											0.48	0.54	0.57
Information Bit Payload (Note 5)													
For Sub-Frames 4,9	Bits	5160	8760	18336	1352	3368	5736	12960	19080	7992	6968	7992	15264
For Sub-Frames 1,6	Bits	3880	7480	14688	1128	3112	5160	10680	15840	5736	5160	5736	12216
For Sub-Frame 5	Bits	N/A	N/A	N/A	N/A	N/A	N/A	N/A	N/A	N/A	N/A	N/A	N/A
For Sub-Frame 0	Bits	5160	8760	N/A	N/A	N/A	N/A	N/A	N/A	7992	N/A	N/A	14112
Number of Code Blocks (Notes 4 and 5)													
For Sub-Frames 4,9		1	2	3	1	1	1	3	4	2	2	2	3
For Sub-Frames 1,6		1	2	3	1	1	1	2	3	1	1	1	2
For Sub-Frame 5		N/A	N/A	N/A	N/A	N/A	N/A	N/A	N/A	N/A	N/A	N/A	N/A
For Sub-Frame 0		1	2	N/A	N/A	N/A	N/A	N/A	N/A	2	N/A	N/A	3
Binary Channel Bits (Note 5)													
For Sub-Frames 4,9	Bits	13200	26400	39600	2592	7200	12000	26400	39600	13200	12000	12000	26400
For Sub-Frames 1,6	Bits	10656	21312	31968	2304	6192	10512	21312	32112	10656	10656	10656	21312
For Sub-Frame 5	Bits	N/A	N/A	N/A	N/A	N/A	N/A	N/A	N/A	N/A	N/A	N/A	N/A
For Sub-Frame 0	Bits	12528	25056	N/A	N/A	N/A	N/A	N/A	N/A	12528	N/A	N/A	25056
Max. Throughput averaged over 1 frame (Note 5)	Mbps	2.324	4.124	6.604	0.496	1.296	2.179	4.498	6.984	3.5448	2.4256	2.7456	6.9072
UE Category		≥ 1	≥ 1	≥ 2	≥ 1	≥ 1	≥ 1	≥ 2	≥ 2	≥ 2	≥ 1	≥ 1	≥ 1

Note 1: Void

Note 2: Reference signal, synchronization signals and PBCH allocated as per TS 36.211 [4].

Note 3: As per Table 4.2-2 in TS 36.211 [4].

Note 4: If more than one Code Block is present, an additional CRC sequence of L = 24 Bits is attached to each Code Block (otherwise L = 0 Bit).

Note 5: Given per component carrier per codeword



Table A.3.4.2.1-3: Fixed Reference Channel two antenna ports

Parameter	Unit	Value	
		R.62 TDD	R.63 TDD
Reference channel		R.62 TDD	R.63 TDD
Channel bandwidth	MHz	10	10
Allocated resource blocks (Note 4)		3	1
Uplink-Downlink Configuration (Note 3)		1	1
Allocated subframes per Radio Frame (D+S)		4+2	4+2
Modulation		16QAM	64QAM
Target Coding Rate		1/2	1/2
Information Bit Payload			
For Sub-Frames 0,4,5,9	Bits	744	408
For Sub-Frames 1,6	Bits	440	280
Number of Code Blocks			
For Sub-Frames 0,4,5,9	Code blocks	1	1
For Sub-Frames 1,6	Code blocks	1	1
Binary Channel Bits			
For Sub-Frames 0,4,5,9	Bits	1584	792
For Sub-Frames 1,6		1296	648
Max. Throughput averaged over 1 frame	Mbps	0.3856	0.2192
UE DL Category		0	0
Note 1: 2 symbols allocated to PDCCH.			
Note 2: Reference signal, synchronization signals and PBCH allocated as per TS 36.211 [4].			
Note 3: As per Table 4.2-2 in TS 36.211 [4].			
Note 4: Allocated PRB positions start from {9, 10, ..., 9+N-1}, where N is the number of allocated resource blocks.			

Table A.3.4.2.1-4: Fixed Reference Channel two antenna ports

Parameter	Unit	Value	
		R.65 TDD	R.84 TDD
Reference channel		R.65 TDD	R.84 TDD
Channel bandwidth	MHz	20	10
Allocated resource blocks (Note 5)		100	39
Uplink-Downlink Configuration (Note 3)		1	1
Allocated subframes per Radio Frame (D+S)		2+2	3+2
Modulation		256QAM	16QAM
Target Coding Rate			1/2
Information Bit Payload (Note 5)			
For Sub-Frames 4,9	Bits	63776	9912
For Sub-Frames 1,6		46888	7480
For Sub-Frame 5	Bits	N/A	N/A
For Sub-Frame 0	Bits	N/A	9912
Number of Code Blocks (Notes 4 and 5)			
For Sub-Frames 4,9		11	2
For Sub-Frames 1,6		9	2
For Sub-Frame 5		N/A	N/A
For Sub-Frame 0		N/A	2
Binary Channel Bits (Note 5)			
For Sub-Frames 4,9	Bits	115200	20592
For Sub-Frames 1,6		95424	16848
For Sub-Frame 5	Bits	N/A	N/A
For Sub-Frame 0	Bits	N/A	20592
Max. Throughput averaged over 1 frame (Note 5)	Mbps	22.133	4.4696
UE Category		11-12	1bis
UE DL Category		≥ 11	N/A
Note 1:	2 symbols allocated to PDCCH for 20 MHz, 15 MHz and 10 MHz channel BW; 3 symbols allocated to PDCCH for 5 MHz and 3 MHz; 4 symbols allocated to PDCCH for 1.4 MHz. For subframe 1&6, only 2 OFDM symbols are allocated to PDCCH. For 256QAM reference channel 1 symbol is allocated.		
Note 2:	Reference signal, synchronization signals and PBCH allocated as per TS 36.211 [4].		
Note 3:	As per Table 4.2-2 in TS 36.211 [4].		
Note 4:	If more than one Code Block is present, an additional CRC sequence of L = 24 Bits is attached to each Code Block (otherwise L = 0 Bit).		
Note 5:	Given per component carrier per codeword		

Table A.3.4.2.1-5: Fixed Reference Channel two antenna ports when *EIMTA-MainConfigServCell-r12* is configured

Parameter	Unit	Value						
		R.67 TDD						
Reference channel		R.67 TDD						
Channel bandwidth	MHz	10						
Allocated resource blocks (Note 5)		50						
Modulation		16QAM						
Target Coding Rate		0.4						
Dynamic Uplink-Downlink Configuration (Note 3)		0	1	2	3	4	5	6
Allocated subframes per Radio Frame (D+S)		1+2	3+2	5+2	5+1	6+1	7+1	2+2
Information Bit Payload (Note 5)								
For Sub-Frame 0	Bits	9912	9912	9912	9912	9912	9912	9912
For Sub-Frame 1	Bits	7480	7480	7480	7480	7480	7480	7480
For Sub-Frame 2	Bits	NA	NA	NA	NA	NA	NA	NA
For Sub-Frame 3	Bits	NA	NA	9912	NA	NA	9912	NA
For Sub-Frame 4	Bits	NA	9912	9912	NA	9912	9912	NA
For Sub-Frame 5	Bits	NA	NA	NA	NA	NA	NA	NA
For Sub-Frame 6	Bits	7480	7480	7480	9912	9912	9912	7480
For Sub-Frame 7	Bits	NA	NA	NA	9912	9912	9912	NA
For Sub-Frame 8	Bits	NA	NA	9912	9912	9912	9912	NA

For Sub-Frame 9	Bits	NA	9912	9912	9912	9912	9912	9912
Number of Code Blocks (Notes 4 and 5)								
For Sub-Frame 0		2	2	2	2	2	2	2
For Sub-Frame 1		2	2	2	2	2	2	2
For Sub-Frame 2		NA	NA	NA	NA	NA	NA	NA
For Sub-Frame 3		NA	NA	2	NA	NA	2	NA
For Sub-Frame 4		NA	2	2	NA	2	2	NA
For Sub-Frame 5		NA	NA	NA	NA	NA	NA	NA
For Sub-Frame 6		2	2	2	2	2	2	2
For Sub-Frame 7		NA	NA	NA	2	2	2	NA
For Sub-Frame 8		NA	NA	2	2	2	2	NA
For Sub-Frame 9		NA	2	2	2	2	2	2
Binary Channel Bits (Note 5)								
For Sub-Frame 0	Bits	25056	25056	25056	25056	25056	25056	25056
For Sub-Frame 1	Bits	21312	21312	21312	21312	21312	21312	21312
For Sub-Frame 2	Bits	NA	NA	NA	NA	NA	NA	NA
For Sub-Frame 3	Bits	NA	NA	26400	NA	NA	26400	NA
For Sub-Frame 4	Bits	NA	26400	26400	NA	26400	26400	NA
For Sub-Frame 5	Bits	NA	NA	NA	NA	NA	NA	NA
For Sub-Frame 6	Bits	21312	21312	21312	26112	26112	26112	21312
For Sub-Frame 7	Bits	NA	NA	NA	26400	26400	26400	NA
For Sub-Frame 8	Bits	NA	NA	26400	26400	26400	26400	NA
For Sub-Frame 9	Bits	NA	26400	26400	26400	26400	26400	26400
Max. Throughput averaged over 1 frame (Note 5)	Mbps	2.49	4.47	6.45	5.70	6.70	7.69	3.48
Max. Throughput averaged over 1 frame and over all dynamic UL-DL configurations (Note 5)	Mbps	5.28						
UE Category		≥ 1						
Note 1:	2 OFDM symbols are allocated to PDCCH in all subframes							
Note 2:	Reference signal, synchronization signals and PBCH allocated as per TS 36.211 [4].							
Note 3:	As per Table 4.2-2 in TS 36.211 [4].							
Note 4:	If more than one Code Block is present, an additional CRC sequence of L = 24 Bits is attached to each Code Block (otherwise L = 0 Bit).							
Note 5:	Given per component carrier per codeword.							

Table A.3.4.2.1-6: Fixed Reference Channel two antenna ports

Parameter	Unit	Values		
		R.79 TDD	R.103 TDD	R.104 TDD
Reference channel		R.79 TDD	R.103 TDD	R.104 TDD
Channel bandwidth	MHz	10	10	10
Allocated resource blocks (Note 4)		3	3	3
Allocated subframes per Radio Frame (D+S)		4+2	(Note 5)	4
Modulation		16QAM	QPSK	64QAM
Target Coding Rate		1/2	1/3	0.4
Information Bit Payload				
For Sub-Frames 0,4,5,9	Bits	744	224	968
For Sub-Frames 1,6	Bits	440	N/A	N/A
Number of Code Blocks				
For Sub-Frames 0,4,5,9	Code blocks	1	1	1
For Sub-Frames 0,4,5,9	Code blocks	1	1	1
Binary Channel Bits				
For Sub-Frames 0,4,5,9	Bits	1584	792	2376
For Sub-Frames 1,6	Bits	1296	N/A	N/A
Max. Throughput averaged over 1 frame	Mbps	0.3856	0.0112	0.3872
UE DL Category		M1, M2 ≥ 0	M1, M2	M1, M2
Note 1:	2 symbols allocated to PDCCH.			
Note 2:	Reference signal, synchronization signals and PBCH allocated as per TS 36.211 [4].			
Note 3:	As per Table 4.2-2 in TS 36.211 [4].			
Note 4:	Allocated PRB positions for PDSCH are {3, 4, 5} within the assigned narrowband. Allocated PRB positions for MPDCCH are {0, 1} within the assigned narrowband.			
Note 5:	MPDCCH are scheduled at the 0th to 3rd BL/CE DL subframes with repetition every period=20ms. The associated PDSCH is scheduled at the 5th BL/CE DL subframe with repetition every period=20ms (starting from the 0th subframe).			

Table A.3.4.2.1-7: Fixed Reference Channel two antenna ports

Parameter	Unit	Value		
		R.81 TDD	R.81-1 TDD	R.81-2 TDD
Reference channel		R.81 TDD	R.81-1 TDD	R.81-2 TDD
Channel bandwidth	MHz	10	10	10
Allocated resource blocks (Note 4)		6	6	6
Uplink-Downlink Configuration (Note 3)		1	1	1
Allocated PDSCH subframes		Note 6	Note 7	Note 8
Modulation		QPSK	QPSK	QPSK
Target Coding Rate		1/10	1/10	1/10
Information Bit Payload				
For Sub-Frames 0,4,5,9	Bits	152	152	152
For Sub-Frames 1,6	Bits	N/A	N/A	N/A
Number of Code Blocks				
For Sub-Frames 0,4,5,9	Code blocks	1	1	1
For Sub-Frames 1,6	Code blocks	N/A	N/A	N/A
Binary Channel Bits				
For Sub-Frames 0,4,5,9	Bits	1584	1584	1584
For Sub-Frames 1,6		N/A	N/A	N/A
Max. Throughput averaged over one period	kbps	0.297	0.594	1.9
UE DL Category		M1, ≥ 0	≥ 1	≥ 1
<p>Note 1: 2 symbols allocated to PDCCH.</p> <p>Note 2: Reference signal, synchronization signals and PBCH allocated as per TS 36.211 [4].</p> <p>Note 3: As per Table 4.2-2 in TS 36.211 [4].</p> <p>Note 4: Allocated PRB positions are {0, 1, 2, 3, 4, 5} within the assigned narrowband.</p> <p>Note 5: The allocated PRB positions are {0, 1, 2, 3, 4, 5} within the assigned narrowband. If it is not the BL/CE DL subframes, MPDCCH/PDSCH transmission is postponed until the next BL/CE DL subframe. Note the DL subframes in the TDD uplink-downlink configuration are considered as the BL/CE DL subframes.</p> <p>Note 6: MPDCCH are scheduled at the 0th to 63rd BL/CE DL subframes with repetition every period=512ms. The associated PDSCH is scheduled at the 65th to 128th BL/CE DL subframes with repetition every 512ms (starting from the 0th subframe).</p> <p>Note 7: MPDCCH are scheduled at the 0th to 31rd BL/CE DL subframes with repetition every period=256ms. The associated PDSCH is scheduled at the 33rd to 64 rd BL/CE DL subframes with repetition every 256ms (starting from the 0th subframe).</p> <p>Note 8: MPDCCH are scheduled at the 0th to 7rd BL/CE DL subframes with repetition every period=80ms. The associated PDSCH is scheduled at the 9rd to 24 rd BL/CE DL subframes with repetition every 80ms (starting from the 0th subframe).</p>				

Table A.3.4.2.1-8: Fixed Reference Channel two antenna ports

Parameter	Unit	Values						
		R.87 TDD	R.87-1 TDD	R.aa TDD	R.bb TDD	R.87-2 TDD	R.87-3 TDD	R.87-4 TDD
Reference channel		R.87 TDD	R.87-1 TDD	R.aa TDD	R.bb TDD	R.87-2 TDD	R.87-3 TDD	R.87-4 TDD
Channel bandwidth	MHz	10	10	10	10	5	15	20
Allocated resource blocks (Note 4)		50	50	50	50	25	75	100
Uplink-Downlink Configuration (Note 2)		1	1	1	1	1	1	1
Allocated number of PDCCH symbols		2	2	2	2	2	2	2
Allocated subframes per Radio Frame (D+S)		2+2	2+2	3+2	3+2	2+2	2+2	2+2

Modulation		64QAM	16QAM	QPSK	16QAM	64QAM	64QAM	64QAM
Target Coding Rate								
For Sub-Frames 4,9		0.39	0.44	0.61	0.3	0.39	0.39	0.39
For Sub-Frames 1,6		0.36	0.40	0.54	0.27	0.36	0.36	0.36
For Sub-Frames 0		N/A	N/A	0.64	0.32	N/A	N/A	N/A
For Sub-Frames 5		N/A	N/A	N/A	N/A	N/A	N/A	N/A
Information Bit Payload (Note 4)								
For Sub-Frames 4,9	Bits	15264	11448	7992	7992	7736	22920	30576
For Sub-Frames 1,6	Bits	11448	8504	5736	5736	5544	16992	22920
For Sub-Frames 0	Bits	N/A	N/A	7992	7992	N/A	N/A	N/A
For Sub-Frames 5		N/A	N/A	N/A	N/A	N/A	N/A	N/A
Number of Code Blocks(Notes 3 and 4)								
For Sub-Frames 4,9		3	4	2	2	2	4	5
For Sub-Frames 1,6		2	4	2	2	2	2	2
For Sub-Frames 0		N/A	N/A	2	2	N/A	N/A	N/A
For Sub-Frames 5		N/A	N/A	N/A	N/A	N/A	N/A	N/A
Binary Channel Bits (Note 4)								
For Sub-Frames 4,9	Bits	39600	26400	13200	26400	19800	59400	79200
For Sub-Frames 1,6		31968	21312	10656	21312	15768	48168	64368
For Sub-Frames 0		N/A	N/A	12528	25056	N/A	N/A	N/A
For Sub-Frames 5		N/A	N/A	N/A	N/A	N/A	N/A	N/A
Max. Throughput averaged over 1 frame (Note 4)	Mbps	5.342	3.99	3.5448	3.5448	2.656	7.982	10.699
UE Category		≥ 1	≥ 1	≥ 1	≥ 2	≥ 1	≥ 1	≥ 1
Note 1: Reference signal, synchronization signals and PBCH allocated as per TS 36.211 [4]								
Note 2: As per Table 4.2-2 in TS 36.211 [4].								
Note 3: If more than one Code Block is present, an additional CRC sequence of L = 24 Bits is attached to each Code Block (otherwise L = 0 Bit)								
Note 4: Given per component carrier per codeword.								

Table A.3.4.2.1-9: Fixed Reference Channel two antenna ports

Parameter	Unit	Value		
		R.47-1 TDD	R.47-2 TDD	R.47-3 TDD
Reference channel		R.47-1 TDD	R.47-2 TDD	R.47-3 TDD
Channel bandwidth	MHz	5	15	20
Allocated resource blocks		25	75	100
Uplink-Downlink Configuration (Note 2)		1	1	1
Allocated number of PDCCH symbols in normal subframes		2	2	2
Allocated number of PDCCH symbols in special subframes		2	2	2
Allocated subframes per Radio Frame (D+S)		3+2	3+2	3+2
Modulation		16QAM	16QAM	16QAM
Target Coding Rate				
For Sub-Frames 4,9				
For Sub-Frames 1,6				
Information Bit Payload (Note 4)				
For Sub-Frames 4,9	Bits	4008	12960	17568
For Sub-Frames 1,6		3624	9912	15264
For Sub-Frame 5	Bits	N/A	N/A	N/A
For Sub-Frame 0	Bits	3496	12960	17568
Number of Code Blocks (Notes 3 and 4)				
For Sub-Frames 4,9		1	3	3
For Sub-Frames 1,6		1	2	3
For Sub-Frame 5		N/A	N/A	N/A
For Sub-Frame 0		2	3	3
Binary Channel Bits (Note 4)				
For Sub-Frames 4,9	Bits	12000	39680	52800
For Sub-Frames 1,6		10512	32112	42912
For Sub-Frame 5	Bits	N/A	N/A	N/A
For Sub-Frame 0	Bits	10656	38256	51456
Max. Throughput averaged over 1 frame (Note 4)	Mbps	1.876	5.874	8.3232
UE Category		≥ 1	≥ 1	≥ 1
Note 1:	Reference signal, synchronization signals and PBCH allocated as per TS 36.211 [4].			
Note 2:	As per Table 4.2-2 in TS 36.211 [4].			
Note 3:	If more than one Code Block is present, an additional CRC sequence of L = 24 Bits is attached to each Code Block (otherwise L = 0 Bit).			
Note 4:	Given per component carrier per codeword			

Table A.3.4.2.1-10: Fixed Reference Channel two antenna ports

Parameter	Unit	Value			
		R.90 TDD	R.91 TDD	R.92-1 TDD	R.92-2 TDD
Reference channel		R.90 TDD	R.91 TDD	R.92-1 TDD	R.92-2 TDD
Channel bandwidth	MHz	10	10	10	10
Allocated resource blocks		18 (Note 9)	18 (Note 9)	36 (Note 10)	36 (Note 10)
Uplink-Downlink Configuration (Note 3)		1	1	1	1
Allocated PDSCH subframes		(Note 4)	(Note 5)	(Note 6)	(Note 7)
Modulation		QPSK	QPSK	QPSK	QPSK
Target Coding Rate		1/3	1/10	1/2	1/2
Information Bit Payload					
For Sub-Frames 0,4,5,9	Bits	1544	488	4392	4392
For Sub-Frames 1,6	Bits	N/A	N/A	N/A	N/A
Number of Code Blocks					
For Sub-Frames 0,4,5,9	Code blocks	1	1	1	1
For Sub-Frames 1,6	Code blocks	N/A	N/A	N/A	N/A
Binary Channel Bits					
For Sub-Frames 0,4,5,9	Bits	4752	4752	9504	9504
For Sub-Frames 1,6		N/A	N/A	N/A	N/A
Max. Throughput averaged over one period	kbps	19.3	1.90625	137.25	219.6
UE DL Category		M2	M2	≥ 1	≥ 1
<p>Note 1: 2 symbols allocated to PDCCH.</p> <p>Note 2: Reference signal, synchronization signals and PBCH allocated as per TS 36.211 [4].</p> <p>Note 3: As per Table 4.2-2 in TS 36.211 [4].</p> <p>Note 4: MPDCCH are scheduled at the 0th to 15th BL/CE DL subframes with repetition every period=80ms. The associated PDSCH is scheduled at the 17th to 24th BL/CE DL subframes with repetition every period=80ms (starting from the 0th subframe).</p> <p>Note 5: MPDCCH are scheduled at the 0th to 31st BL/CE DL subframes with repetition every period= 256ms. The associated PDSCH is scheduled at the 33rd to 64th BL/CE DL subframes with repetition every period=256ms (starting from the 0th subframe).</p> <p>Note 6: MPDCCH are scheduled at the 0th to 3rd BL/CE DL subframes with repetition every period=32ms. The associated PDSCH is scheduled at the 5th to 8th BL/CE DL subframes with repetition every period=32ms (starting from the 0th subframe).</p> <p>Note 7: MPDCCH are scheduled at the 0th to 1st BL/CE DL subframes with repetition every period=20ms. The associated PDSCH is scheduled at the 2nd to 3rd BL/CE DL subframes with repetition every period=20ms (starting from the 0th subframe).</p> <p>Note 8: If it is not the BL/CE DL subframes, MPDCCH/PDSCH transmission is postponed until the next BL/CE DL subframe. Note the DL subframes in the TDD uplink-downlink configuration are considered as the BL/CE DL subframes.</p> <p>Note 9: Allocated PRB positions are {0, 1, ..., 17} within the assigned wideband.</p> <p>Note 10: Allocated PRB positions are {1, 2, 3, ..., 18, 31, 32, ..., 48}.</p> <p>Note 11: Allocated PRB positions for MPDCCH are {0, 1, 2, 3, 4, 5} within the scheduled narrowband.</p>					



Table A.3.4.2.1-11: Fixed Reference Channel two antenna ports

Parameter	Unit	Value
Reference channel		R.11-13 TDD
Channel bandwidth	MHz	10
Allocated resource blocks (Note 5)		50
Uplink-Downlink Configuration (Note 3)		4
Special subframe configuration		4
Allocated subframes per Radio Frame (D+S)		7+1
Modulation		16QAM
Target Coding Rate		1/2
Information Bit Payload (Note 5)		
For Sub-Frames 0,4,6,7,8,9	Bits	10680
For Sub-Frames 1		7736
For Sub-Frames 5		NA
Number of Code Blocks (Notes 4 and 5)		
For Sub-Frames 0,4,5,6,7,8,9		2
For Sub-Frames 1		2
For Sub-Frames 5		NA
Binary Channel Bits (Note 5)		
For Sub-Frames 0,4,5,6,7,8,9	Bits	21648
For Sub-Frames 1		17424
For Sub-Frames 5		NA
Max. Throughput averaged over 1 frame (Note 5)	Mbps	7.1816
UE Category		≥ 2
Note 1: 2 symbols allocated to PDCCH. Note 2: Reference signal, synchronization signals and PBCH allocated as per TS 36.211 [4]. Note 3: As per Table 4.2-2 in TS 36.211 [4]. Note 4: If more than one Code Block is present, an additional CRC sequence of L = 24 Bits is attached to each Code Block (otherwise L = 0 Bit). Note 5: Given per component carrier per codeword. Note 6: 41 resource blocks (RB0–RB20 and RB30–RB49) are allocated in sub-frame 0,1,4,5,6,7,8,9.		

## A.3.4.2.2 Four antenna ports

Table A.3.4.2.2-1: Fixed Reference Channel four antenna ports

Parameter	Unit	Value												
		R.12 TDD	R.13 TDD	R.14 TDD	R.14-1 TDD	R.14-2 TDD	R.43 TDD	R.36 TDD	R.43-1 TDD	R.43-2 TDD	R.43-3 TDD	R.43-4 TDD	R.43-5 TDD	R.36-1 TDD
Reference channel		1.4	10	10	10	10	20	10	1.4	3	5	10	15	10
Channel bandwidth	MHz	6	50	50	6	3	100	50	6	15	25	50	75	50
Allocated resource blocks (Note 6)		1	1	1	1	1	1	1	1	1	1	1	1	1
Uplink-Downlink Configuration (Note 4)		3	3+2	2+2	2	2	2+2	2+2	2	2+2	2+2	2+2	2+2	2+2
Allocated subframes per Radio Frame (D+S)		QPSK	QPSK	16QA M	16QAM	16QAM	16QA M	64QA M	16QAM	16QAM	16QAM	16QAM	16QAM	64QAM
Modulation		1/3	1/3	1/2	1/2	1/2	1/2	1/2	1/2	1/2	1/2	1/2	1/2	0.55
Target Coding Rate														
Information Bit Payload (Note 6)		408	4392	12960	1544	744	25456	18336	1192	3368	5736	12960	19080	21384
For Sub-Frames 4,9	Bits	N/A	3240	9528	N/A	N/A	21384	15840	N/A	2856	5160	10680	15840	16992
For Sub-Frames 1,6	Bits	N/A	N/A	N/A	N/A	N/A	N/A	N/A	N/A	N/A	N/A	N/A	N/A	N/A
For Sub-Frame 5	Bits	208	4392	N/A	N/A	N/A	N/A	N/A	N/A	N/A	N/A	N/A	N/A	N/A
For Sub-Frame 0	Bits													
Number of Code Blocks (Notes 5 and 6)		1	1	3	1	1	5	3	1	1	1	3	4	4
For Sub-Frames 4,9		N/A	1	2	N/A	N/A	4	3	N/A	1	1	2	3	3
For Sub-Frames 1,6		N/A	N/A	N/A	N/A	N/A	N/A	N/A	N/A	N/A	N/A	N/A	N/A	N/A
For Sub-Frame 5		1	1	N/A	N/A	N/A	N/A	N/A	N/A	N/A	N/A	N/A	N/A	N/A
For Sub-Frame 0														
Binary Channel Bits (Note 6)		1248	12800	25600	3072	1536	51200	38400	2496	6960	11600	25600	38400	38400
For Sub-Frames 4,9	Bits	N/A	10256	20512	N/A	N/A	41312	30768	N/A	5952	10112	20512	30912	30768
For Sub-Frames 1,6		N/A	N/A	N/A	N/A	N/A	N/A	N/A	N/A	N/A	N/A	N/A	N/A	N/A
For Sub-Frame 5	Bits	624	12176	N/A	N/A	N/A	N/A	N/A	N/A	N/A	N/A	N/A	N/A	N/A
For Sub-Frame 0	Bits	0.102	1.966	4.498	0.309	0.149	9.368	6.835	0.238	1.245	2.179	4.728	6.984	7.675
Max. Throughput averaged over 1 frame (Note 6)	Mbps	≥ 1	≥ 1	≥ 2	≥ 1	≥ 1	≥ 2	≥ 2	≥ 1	≥ 1	≥ 1	≥ 2	≥ 2	≥ 2
UE Category		<p>Note 1: 2 symbols allocated to PDCCH for 20 MHz, 15 MHz and 10 MHz channel BW; 3 symbols allocated to PDCCH for 5 MHz and 3 MHz; 4 symbols allocated to PDCCH for 1.4 MHz. For subframe 1&amp;6, only 2 OFDM symbols are allocated to PDCCH.</p> <p>Note 2: For BW=1.4 MHz, the information bit payloads of special subframes are set to zero (no scheduling) to avoid problems with insufficient PDCCH performance at the test point.</p> <p>Note 3: Reference signal, synchronization signals and PBCH allocated as per TS 36.211 [4].</p> <p>Note 4: As per Table 4.2-2 in TS 36.211 [4].</p>												

Note 5: If more than one Code Block is present, an additional CRC sequence of  $L = 24$  Bits is attached to each Code Block (otherwise  $L = 0$  Bit).

Note 6: Given per component carrier per codeword.

**Table A.3.4.2.2-2: Fixed Reference Channel four antenna ports**

*ETSI*

Parameter	Unit	Value								
		R.72 TDD	R.72-1 TDD	R.72-2 TDD	R.72-3 TDD	R.73 TDD	R.73-1 TDD	R.74 TDD	R.85 TDD	R.93 TDD
Reference channel		R.72 TDD	R.72-1 TDD	R.72-2 TDD	R.72-3 TDD	R.73 TDD	R.73-1 TDD	R.74 TDD	R.85 TDD	R.93 TDD
Channel bandwidth	MHz	10	5	15	20	10	10	10	10 (Note 7)	10 (Note 7)
Allocated resource blocks (Note 6)		50	25	75	100	50	50	50	24	24
Uplink-Downlink Configuration (Note 4)		1	1	1	1	1	1	1	1	1
Allocated subframes per Radio Frame (D+S)		2+2	2+2	2+2	2+2	2+2	2+2	2+2	3+2	3+2
Modulation		256QAM	256QAM	256QAM	256QAM	64QAM	16QAM	16QAM	64QAM	64QAM
Target Coding Rate		0.60	0.62	0.59	0.60	0.44	1/2	1/2	1/2	0.5
Information Bit Payload (Note 6)										
For Sub-Frames 4,9	Bits	31704	15840	46888	63776	16416 (CW0) 32856 (CW1)	12960 (CW0) 25456 (CW1)	25456	10296	9528
For Sub-Frames 1,6	Bits	23688	11448	35160	46888	12216 (CW0) 24496 (CW1)	9528 (CW0) 19080 (CW1)	19080	8248	7224
For Sub-Frame 5	Bits	N/A	N/A	N/A	N/A	N/A	N/A	N/A	N/A	N/A
For Sub-Frame 0	Bits	N/A	N/A	N/A	N/A	N/A	N/A	N/A	10296	9528
Number of Code Blocks (Notes 5 and 6)										
For Sub-Frames 4,9		6	3	8	11	3 (CW0) 6 (CW1)	3 (CW0) 5 (CW1)	5	2	2
For Sub-Frames 1,6		4	2	6	8	2 (CW0) 4 (CW1)	2 (CW0) 4 (CW1)	4	2	2
For Sub-Frame 5		N/A	N/A	N/A	N/A	N/A	N/A	N/A	N/A	N/A
For Sub-Frame 0		N/A	N/A	N/A	N/A	N/A	N/A	N/A	2	2
Binary Channel Bits (Note 6)										
For Sub-Frames 4,9	Bits	51200	23200	76800	102400	38400 (CW0) 76800 (CW1)	25600 (CW0) 51200 (CW1)	51200	18432	18432
For Sub-Frames 1,6		41024	20224	61824	82624	30768 (CW0) 61536 (CW1)	21312 (CW0) 42624 (CW1)	41024	14976	14976
For Sub-Frame 5	Bits	N/A	N/A	N/A	N/A	N/A	N/A	N/A	N/A	N/A
For Sub-Frame 0	Bits	N/A	N/A	N/A	N/A	N/A	N/A	N/A	18432	18432
Max. Throughput averaged over 1 frame (Note 6)	Mbps	11.0784	5.4576	16.4096	22.1328	5.726 (CW0) 11.470 (CW1)	4.498 (CW0) 8.907 (CW1)	8.907	4.7384	4.303
UE Category		≥ 11	≥ 11	≥ 11	≥ 11	≥ 5	≥ 5	≥ 5	1bis	1bis

- Note 1: 2 symbols allocated to PDCCH for 20 MHz, 15 MHz and 10 MHz channel BW; 3 symbols allocated to PDCCH for 5 MHz and 3 MHz; 4 symbols allocated to PDCCH for 1.4 MHz. For subframe 1&6, only 2 OFDM symbols are allocated to PDCCH.
- Note 2: For BW=1.4 MHz, the information bit payloads of special subframes are set to zero (no scheduling) to avoid problems with insufficient PDCCH performance at the test point.
- Note 3: Reference signal, synchronization signals and PBCH allocated as per TS 36.211 [4].
- Note 4: As per Table 4.2-2 in TS 36.211 [4].
- Note 5: If more than one Code Block is present, an additional CRC sequence of L = 24 Bits is attached to each Code Block (otherwise L = 0 Bit).
- Note 6: Given per component carrier per codeword.
- Note 7: 24 resource blocks (RB 0-20 and 30-32) are allocated in sub-frames 0, 1, 2, 3, 4, 6, 7, 8, 9

Table A.3.4.2.2-3: Fixed Reference Channel four antenna ports

Parameter	Unit	Value			
		R.74-1 TDD	R.74-2 TDD	R.74-3 TDD	R.101 TDD
Reference channel					
Channel bandwidth	MHz	5	15	20	10
Allocated resource blocks (Note 6)		25	75	100	50
Uplink-Downlink Configuration (Note 4)		1	1	1	1
Allocated subframes per Radio Frame (D+S)		2+2	2+2	2+2	3+2
Modulation		16QAM	16QAM	16QAM	1024QAM
Target Coding Rate		1/2	1/2	1/2	
Information Bit Payload (Note 6)					
For Sub-Frames 4,9	Bits	11448	37888	51024	52752
For Sub-Frames 1,6	Bits	10296	31704	42368	39232
For Sub-Frame 5	Bits	N/A	N/A	N/A	N/A
For Sub-Frame 0	Bits	N/A	N/A	N/A	52752
Number of Code Blocks					
For Sub-Frames 4,9		2	7	9	9
For Sub-Frames 1,6		2	5	7	9
For Sub-Frame 0,5		N/A	N/A	N/A	N/A
Binary Channel Bits					
For Sub-Frames 4,9	Bits	23200	76800	102400	68000
For Sub-Frames 1,6	Bits	20224	61824	82624	55280
For Sub-Frame 5	Bits	N/A	N/A	N/A	N/A
For Sub-Frame 0	Bits	N/A	N/A	N/A	65600
Max. Throughput averaged over 1 frame (Note 5)	Mbps	4.3488	13.9184	18.6784	23.6720
UE Category		≥ 5	≥ 5	≥ 5	TBD
UE DL Category		-	-	-	20, ≥ 22
Note 1:	2 symbols allocated to PDCCH for 20 MHz, 15 MHz and 10 MHz channel BW; 3 symbols allocated to PDCCH for 5 MHz and 3 MHz; 4 symbols allocated to PDCCH for 1.4 MHz. For subframe 1&6, only 2 OFDM symbols are allocated to PDCCH. 1 symbol allocated to PDCCH for reference channel with 1024QAM.				
Note 2:	Reference signal, synchronization signals and PBCH allocated as per TS 36.211 [4].				
Note 3:	As per Table 4.2-2 in TS 36.211 [4].				
Note 4:	If more than one Code Block is present, an additional CRC sequence of L = 24 Bits is attached to each Code Block (otherwise L = 0 Bit).				
Note 5:	Given per component carrier per codeword.				

Table A.3.4.2.2-4: Fixed Reference Channel four antenna ports

Parameter	Unit	Values
Reference channel		R.95 TDD
Channel bandwidth	MHz	10
Allocated resource blocks (Note 4)		3
Allocated subframes per Radio Frame (D+S)		4+2
Modulation		16QAM
Target Coding Rate		1/2
Information Bit Payload		
For Sub-Frames 0,4,5,9	Bits	744
For Sub-Frames 1,6	Bits	440
Number of Code Blocks		
For Sub-Frames 0,4,5,9	Code blocks	1
For Sub-Frames 0,4,5,9	Code blocks	1
Binary Channel Bits		
For Sub-Frames 0,4,5,9	Bits	1536
For Sub-Frames 1,6	Bits	1248
Max. Throughput averaged over 1 frames	Mbps	0.3856
UE DL Category		M2
Note 1:	2 symbols allocated to PDCCH.	
Note 2:	Reference signal, synchronization signals and PBCH allocated as per TS 36.211 [4].	
Note 3:	As per Table 4.2-2 in TS 36.211 [4].	
Note 4:	Allocated PRB positions for PDSCH are {3, 4, 5} within the assigned narrowband. Allocated PRB positions for MPDCCH are {0, 1} within the assigned narrowband.	



### A.3.4.3 Reference Measurement Channels for UE-Specific Reference Symbols

#### A.3.4.3.1 Single antenna port (Cell Specific)

The reference measurement channels in Table A.3.4.3.1-1 apply for verifying demodulation performance for UE-specific reference symbols with one cell-specific antenna port.

**Table A.3.4.3.1-1: Fixed Reference Channel for DRS**

Parameter	Unit	Value					
		R.25 TDD	R.26 TDD	R.26-1 TDD	R.27 TDD	R.27-1 TDD	R.28 TDD
Reference channel							
Channel bandwidth	MHz	10	10	5	10	10	10
Allocated resource blocks		50 <sup>4</sup>	50 <sup>4</sup>	25 <sup>4</sup>	50 <sup>4</sup>	18 <sup>6</sup>	1
Uplink-Downlink Configuration (Note 3)		1	1	1	1	1	1
Allocated subframes per Radio Frame (D+S)		3+2	3+2	3+2	3+2	3+2	3+2
Modulation		QPSK	16QAM	16QAM	64QAM	64QAM	16QAM
Target Coding Rate		1/3	1/2	1/2	3/4	3/4	1/2
Information Bit Payload							
For Sub-Frames 4,9	Bits	4392	12960	5736	28336	10296	224
For Sub-Frames 1,6	Bits	3240	9528	4584	22920	8248	176
For Sub-Frame 5	Bits	N/A	N/A	N/A	N/A	N/A	N/A
For Sub-Frame 0	Bits	2984	9528	3880	22152	10296	224
Number of Code Blocks per Sub-Frame (Note 5)							
For Sub-Frames 4,9		1	3	1	5	2	1
For Sub-Frames 1,6		1	2	1	4	2	1
For Sub-Frame 5		N/A	N/A	N/A	N/A	N/A	N/A
For Sub-Frame 0		1	2	1	4	2	1
Binary Channel Bits Per Sub-Frame							
For Sub-Frames 4,9	Bits	12600	25200	11400	37800	13608	504
For Sub-Frames 1,6	Bits	10356	20712	10212	31068	11340	420
For Sub-Frame 5	Bits	N/A	N/A	N/A	N/A	N/A	N/A
For Sub-Frame 0	Bits	10332	20664	7752	30996	13608	504
Max. Throughput averaged over 1 frame	Mbps	1.825	5.450	2.452	12.466	4.738	0.102
UE Category		≥ 1	≥ 2	≥ 1	≥ 2	≥ 1	≥ 1
Note 1:	2 symbols allocated to PDCCH for 20 MHz, 15 MHz and 10 MHz channel BW; 3 symbols allocated to PDCCH for 5 MHz and 3 MHz; 4 symbols allocated to PDCCH for 1.4 MHz. For subframe 1&6, only 2 OFDM symbols are allocated to PDCCH.						
Note 2:	Reference signal, synchronization signals and PBCH allocated as per TS 36.211 [4].						
Note 3:	as per Table 4.2-2 in TS 36.211 [4].						
Note 4:	For R.25, R.26 and R.27, 50 resource blocks are allocated in sub-frames 1, 4, 6, 9 and 41 resource blocks (RB0–RB20 and RB30–RB49) are allocated in sub-frame 0. For R.26-1, 25 resource blocks are allocated in sub-frames 1, 4, 6, 9 and 17 resource blocks (RB0–RB7 and RB16–RB24) are allocated in sub-frame 0.						
Note 5:	If more than one Code Block is present, an additional CRC sequence of L = 24 Bits is attached to each Code Block (otherwise L = 0 Bit).						
Note 6:	Localized allocation started from RB #0 is applied.						

The reference measurement channels in Table A.3.4.3.1-2 apply for verifying demodulation performance for UE-specific reference symbols with one cell-specific antenna port.

Table A.3.4.3.1-2: Fixed Reference Channel for DRS

Parameter	Unit	Value		
		R.80 TDD	R.80-1 TDD	R.80-2 TDD
Reference channel				
Channel bandwidth	MHz	10	10	10
Allocated resource blocks (Note 4)		6	6	6
Uplink-Downlink Configuration (Note 3)		1	1	1
Allocated PDSCH subframes		Note 6	Note 7	Note 8
Modulation		QPSK	QPSK	QPSK
Target Coding Rate		1/3	1/3	1/3
Information Bit Payload				
For Sub-Frames 4,9	Bits	504	504	504
For Sub-Frames 1,6		N/A	N/A	N/A
For Sub-Frames 0,5	Bits	504	504	504
Number of Code Blocks per Sub-Frame				
For Sub-Frames 4,9	Code blocks	1	1	1
For Sub-Frames 1,6	Code blocks	N/A	N/A	N/A
For Sub-Frames 0,5	Code blocks	1	1	1
Binary Channel Bits Per Sub-Frame				
For Sub-Frames 4,9	Bits	1440	1440	1440
For Sub-Frames 1,6		N/A	N/A	N/A
For Sub-Frames 0,5	Bits	1440	1440	1440
Max. Throughput averaged over one period	kbps	6.3	12.6	25.2
UE DL Category		M1, ≥ 0	≥ 1	≥ 1
Note 1: 2 symbols allocated to PDCCH. Note 2: Reference signal, synchronization signals and PBCH allocated as per TS 36.211 [4]. Note 3: as per Table 4.2-2 in TS 36.211 [4]. Note 4: Allocated PRB positions are {0, 1, 2, 3, 4, 5} within the assigned narrowband. Note 5: The allocated PRB positions are {0, 1, 2, 3, 4, 5} within the assigned narrowband. If it is not BL/CE DL subframes, MPDCCH/PDSCH transmission is postponed until the next BL/CE DL subframe. Note the DL subframes in the TDD uplink-downlink configuration are considered as the BL/CE DL subframes. Note 6: MPDCCH are scheduled at the 0th to 7th BL/CE DL subframes with repetition every period=80ms. The associated PDSCH is scheduled at the 9th to 16th BL/CE DL subframes every 80ms (starting from the 0th subframe). Note 7: MPDCCH are scheduled at the 0th to 1th BL/CE DL subframes with repetition every period=40ms. The associated PDSCH is scheduled at the 3th to 6th BL/CE DL subframes every 40ms (starting from the 0th subframe). Note 8: MPDCCH are scheduled at the 0th BL/CE DL subframes with repetition every period=20ms. The associated PDSCH is scheduled at the 1th to 2th BL/CE DL subframes every 20ms (starting from the 0th subframe).				

#### A.3.4.3.2 Two antenna ports (Cell Specific)

The reference measurement channels in Table A.3.4.3.2-1 apply for verifying demodulation performance for CDM-multiplexed UE specific reference symbols with two cell-specific antenna ports.

Table A.3.4.3.2-1: Fixed Reference Channel for CDM-multiplexed DM RS

Parameter	Unit	Value						
		R.31 TDD	R.32 TDD	R.32-1 TDD	R.33 TDD	R.33-1 TDD	R.34 TDD	R.86 TDD
Reference channel								
Channel bandwidth	MHz	10	10	5	10	10	10	10
Allocated resource blocks		50 <sup>4</sup>	50 <sup>4</sup>	25 <sup>4</sup>	50 <sup>4</sup>	18 <sup>6</sup>	50 <sup>4</sup>	50 <sup>4</sup>
Uplink-Downlink Configuration (Note 3)		1	1	1	1	1	1	1
Allocated subframes per Radio Frame (D+S)		3+2	3+2	3+2	3+2	3+2	3+2	3+2
Modulation		QPSK	16QAM	16QAM	64QAM	64QAM	64QAM	QPSK
Target Coding Rate		1/3	1/2	1/2	3/4	3/4	1/2	1/3
Information Bit Payload								
For Sub-Frames 4,9	Bits	3624	11448	5736	27376	9528	18336	4392
For Sub-Frames 1,6		2664	7736	3112	16992	7480	11832	2664
For Sub-Frame 5	Bits	N/A	N/A	N/A	N/A	N/A	N/A	N/A
For Sub-Frame 0	Bits	2984	9528	3496	22152	9528	14688	3624
Number of Code Blocks per Sub-Frame (Note 5)								
For Sub-Frames 4,9		1	2	1	5	2	3	1
For Sub-Frames 1,6		1	2	1	3	2	2	1
For Sub-Frame 5		N/A	N/A	N/A	N/A	N/A	N/A	N/A
For Sub-Frame 0		1	2	1	4	2	3	1
Binary Channel Bits Per Sub-Frame								
For Sub-Frames 4,9	Bits	12000	24000	10800	36000	12960	36000	11400
For Sub-Frames 1,6		7872	15744	6528	23616	10368	23616	7872
For Sub-Frame 5	Bits	N/A	N/A	N/A	N/A	N/A	N/A	N/A
For Sub-Frame 0	Bits	9840	19680	7344	29520	12960	29520	9840
Max. Throughput averaged over 1 frame	Mbps	1.556	4.79	2.119	11.089	4.354	7.502	1.7736
UE Category		≥ 1	≥ 2	≥ 1	≥ 2	≥ 1	≥ 2	1bis
Note 1:	2 symbols allocated to PDCCH for 20 MHz, 15 MHz and 10 MHz channel BW; 3 symbols allocated to PDCCH for 5 MHz and 3 MHz; 4 symbols allocated to PDCCH for 1.4 MHz. For subframe 1&6, only 2 OFDM symbols are allocated to PDCCH.							
Note 2:	Reference signal, synchronization signals and PBCH allocated as per TS 36.211 [4].							
Note 3:	as per Table 4.2-2 in TS 36.211 [4].							
Note 4:	For R.31, R.32, R.33 and R.34, 50 resource blocks are allocated in sub-frames 4,9 and 41 resource blocks (RB0–RB20 and RB30–RB49) are allocated in sub-frame 0 and the DwPTS portion of sub-frames 1,6. For R.32-1, 25 resource blocks are allocated in sub-frames 4,9 and 17 resource blocks (RB0–RB7 and RB16–RB24) are allocated in sub-frame 0 and the DwPTS portion of sub-frames 1, 6.							
Note 5:	If more than one Code Block is present, an additional CRC sequence of L = 24 Bits is attached to each Code Block (otherwise L = 0 Bit).							
Note 6:	Localized allocation started from RB #0 is applied.							

The reference measurement channels in Table A.3.4.3.2-2 apply with two CRS antenna ports.

Table A.3.4.3.2-2: Fixed Reference Channel for CDM-multiplexed DM RS

Reference channel	Parameter		Unit	Value
			R.70 TDD	R.71 TDD
Channel bandwidth	MHz		10	10
Allocated resource blocks			50 (Note 4)	50 (Note 4)
Uplink-Downlink Configuration (Note 3)			1	1
Allocated subframes per Radio Frame (D+S)			2+2	2+2
Modulation			QPSK	16QAM
Target Coding Rate				
For Sub-Frames 4,9			0.65	0.6
For Sub-Frames 1,6			0.54	0.5
Information Bit Payload				
For Sub-Frames 4,9	Bits		6968	12960
For Sub-Frames 1,6	Bits		4264	7736
For Sub-Frame 5	Bits		N/A	N/A
For Sub-Frame 0	Bits		N/A	N/A
Number of Code Blocks per Sub-Frame (Note 5)				
For Sub-Frames 4,9			2	3
For Sub-Frames 1,6			1	2
For Sub-Frame 5			N/A	N/A
For Sub-Frame 0			N/A	N/A
Binary Channel Bits Per Sub-Frame				
For Sub-Frames 4,9	Bits		10800	21600
For Sub-Frames 1,6	Bits		7872	15744
For Sub-Frame 5	Bits		N/A	N/A
For Sub-Frame 0	Bits		N/A	N/A
Max. Throughput averaged over 1 frame	Mbps		2.2464	4.1392
UE Category			≥ 1	≥ 2

Note 1: 3 symbols allocated to PDCCH in normal subframes and 2 symbols allocated to PDCCH in special subframes

Note 2: Reference signal, synchronization signals and PBCH allocated as per TS 36.211 [4].

Note 3: As per Table 4.2-2 in TS 36.211 [4].

Note 4: For R.63, and R.64, 50 resource blocks are allocated in sub-frames 4,9 and 41 resource blocks (RB0–RB20 and RB30–RB49) are allocated in the DwPTS portion of sub-frames 1,6.

Note 5: If more than one Code Block is present, an additional CRC sequence of L = 24 Bits is attached to each Code Block (otherwise L = 0 Bit).

### A.3.4.3.3 Two antenna ports (CSI-RS)

The reference measurement channels in Table A.3.4.3.3-1 apply for verifying demodulation performance for CDM-multiplexed UE specific reference symbols with two cell-specific antenna ports and two CSI-RS antenna ports.

Table A.3.4.3.3-1: Fixed Reference Channel for CDM-multiplexed DM RS with two CSI-RS antenna ports

Parameter	Unit	Value							
		R.51 TDD	R.51-1 TDD	R.76 TDD	R.51-2 TDD	R.51-3 TDD	R.51-4 TDD	R.X TDD	R.94 TDD
Reference channel									
Channel bandwidth	MHz	10	10	10	5	15	20	10	10
Allocated resource blocks		50 (Note 5)	50 (Note 5)	50 (Note 5)	25 (Note 6)	75 (Note 7)	100 (Note 8)	50 (Note 5)	24 (Note 9)
Uplink-Downlink Configuration (Note 3)		1	1	1	1	1	1	1	1
Allocated subframes per Radio Frame (D+S)		3+2	3+2	3+2	3+2	3+2	3+2	3+2	3+2
Modulation		16QAM	16QAM	QPSK	16QAM	16QAM	16QAM	64QAM	QPSK
Target Coding Rate		1/2	0.57		1/2	1/2	1/2	1/2	2/3
Information Bit Payload									
For Sub-Frames 4,9 (non CSI-RS subframe)	Bits	11448	N/A	6200	NA	NA	NA	NA	N/A
For Sub-Frame 4,9	Bits	11448	12960	6200	4968	16992	22920	18336	3752
For Sub-Frames 1,6	Bits	7736	9144	4264	3112	12216	16992	11832	2856
For Sub-Frame 5	Bits	N/A	N/A	n/a	N/A	N/A	N/A	N/A	N/A
For Sub-Frame 0	Bits	9528	10680	4968	3496	14112	19848	14688	3752
Number of Code Blocks (Note 4)									
For Sub-Frames 4, 9 (non CSI-RS subframe)	Code blocks	2	N/A	2	N/A	N/A	N/A	N/A	N/A
For Sub-Frames 4,9	Code blocks	2	3	2	1	3	4	3	1
For Sub-Frames 1,6	Code blocks	2	2	1	1	3	3	3	1
For Sub-Frame 5		N/A	N/A	N/A	N/A	N/A	N/A	N/A	N/A
For Sub-Frame 0	Code blocks	2	2	1	1	3	4	3	1
Binary Channel Bits									
For Sub-Frames 4, 9 (non CSI-RS subframe)	Bits	24000	N/A	11800	NA	NA	NA	N/A	N/A
For Sub-Frames 4,9		22800	22800	11800	10200	34200	45600	34200	5472
For Sub-Frames 1,6		15744	15744	7872	6144	24192	33792	23616	4608
For Sub-Frame 5	Bits	N/A	N/A	N/A	N/A	N/A	N/A	N/A	N/A
For Sub-Frame 0	Bits	19680	19680	9840	6912	30240	42240	29520	5760
Max. Throughput averaged over 1 frame	Mbps	4.7896	5.4888	2.5896	1.9656	7.2528	99.672	7.502	1.697
UE Category		≥ 2	≥ 2	≥ 2	≥ 2	≥ 2	≥ 2	≥ 2	1bis

Note 1: 2 symbols allocated to PDCCH for 20 MHz, 15 MHz and 10 MHz channel BW; 3 symbols allocated to PDCCH for 5 MHz and 3 MHz; 4 symbols allocated to PDCCH for 1.4 MHz. For subframe 1&6, only 2 OFDM symbols are allocated to PDCCH.

Note 2:	Reference signal, synchronization signals and PBCH allocated as per TS 36.211 [4].
Note 3:	as per Table 4.2-2 in TS 36.211 [4].
Note 4:	If more than one Code Block is present, an additional CRC sequence of L = 24 Bits is attached to each Code Block (otherwise L = 0 Bit).
Note 5:	50 resource blocks are allocated in sub-frames 4,9 and 41 resource blocks (RB0–RB20 and RB30–RB49) are allocated in sub-frame 0 and the DwPTS portion of sub-frames 1,6.
Note 6:	25 resource blocks are allocated in sub-frames 4,9 and 17 resource blocks (RB0–RB9 and RB18–RB24) are allocated in sub-frame 0 and the DwPTS portion of sub-frames 1,6.
Note 7:	75 resource blocks are allocated in sub-frames 4,9 and 63 resource blocks (RB0–RB31 and RB44–RB74) are allocated in sub-frame 0 and the DwPTS portion of sub-frames 1,6.
Note 8:	100 resource blocks are allocated in sub-frames 4,9 and 88 resource blocks (RB0–RB43 and RB56–RB99) are allocated in sub-frame 0 and the DwPTS portion of sub-frames 1,6.
Note 9:	24 resource blocks (RB 0-20 and 30-32) are allocated in sub-frames 0, 1, 2, 3, 4, 6, 7, 8, 9

The reference measurement channels in Table A3.4.3.3-2 apply for verifying demodulation performance for UE-specific reference symbols with two cell specific antenna ports and two CSI-RS antenna ports with ZP CSI-RS and NZP CSI-RS in same subframe.

Table A.3.4.3.3-2: Fixed Reference Channel for CDM-multiplexed DM-RS with two CSI-RS antenna ports with ZP CSI-RS and NZP CSI-RS

Parameter	Unit	Value					
		R.52 TDD	R.52-1 TDD	R.53 TDD	R.54 TDD	R.76A TDD	R.97 TDD
Reference channel							
Channel bandwidth	MHz	10	10	10	10	10	10
Allocated resource blocks		50 (Note 5)	50 (Note 5)	50 (Note 5)	50 (Note 5)	50 (Note 5)	50 (Note 5)
Uplink-Downlink Configuration (Note 3)		1	1	1	1	1	1
Allocated subframes per Radio Frame (D+S)		3+2	3+2	3+2	3+2	3+2	3+2
Modulation		64QAM	16QAM	64QAM	16QAM	QPSK	16QAM
Target Coding Rate		1/2	0.57	1/2	1/2	1/3	1/2
Information Bit Payload							
For Sub-Frame 4,9	Bits	16416	12960	16416	11448	3624	11448
For Sub-Frames 1,6	Bits	11832	9144	11832	7736	2664	6712
For Sub-Frame 5	Bits	n/a	n/a	n/a	n/a	n/a	n/a
For Sub-Frame 0	Bits	14688	10680	14688	9528	2984	9528
Number of Code Blocks (Note 4)							
For Sub-Frames 4,9	Code blocks	3	3	3	2	1	2
For Sub-Frames 1,6	Code blocks	2	2	2	2	1	2
For Sub-Frame 5		n/a	n/a	n/a	n/a	n/a	n/a
For Sub-Frame 0	Code blocks	3	2	3	2	1	2
Binary Channel Bits							
For Sub-Frames 4,9		34200	22800	33600	22800	11200	22400
For Sub-Frames 1,6		23616	15744	23616	15744	7544	15744
For Sub-Frame 5	Bits	n/a	n/a	n/a	n/a	n/a	n/a
For Sub-Frame 0	Bits	29520	19680	29520	19680	9512	19680
Max. Throughput averaged over 1 frame	Mbps	7.1184	5.4888	7.1184	4.7896	1.5560	4.5848
UE Category		≥ 2	≥ 2	≥ 2	≥ 2	1	≥ 2
<p>Note 1: 2 symbols allocated to PDCCCH.</p> <p>Note 2: Reference signal, synchronization signals and PBCH allocated as per TS 36.211 [4].</p> <p>Note 3: as per Table 4.2-2 in TS 36.211 [4].</p> <p>Note 4: If more than one Code Block is present, an additional CRC sequence of L = 24 Bits is attached to each Code Block (otherwise L = 0 Bit).</p> <p>Note 5: 50 resource blocks are allocated in sub-frames 4, 9 and 41 resource blocks (RB0–RB20 and RB30–RB49) are allocated in sub-frame 0 and the DwPTS portion of sub-frames 1, 6.</p>							

**Table A.3.4.3.3-3: Fixed Reference Channel for CDM-multiplexed DM RS with two CSI-RS antenna ports**

*ETSI*



Parameter	Unit	Value						
		R.76-1 TDD	R.76-2 TDD	R.76-3 TDD	R.76-4 TDD	R.76-5 TDD	R.76-6 TDD	R.76-7 TDD
Reference channel		5	15	20	5	10	15	20
Channel bandwidth	MHz	25 (Note 6)	75 (Note 7)	100 (Note 8)	25 (Note 6)	50 (Note 5)	75 (Note 7)	100 (Note 8)
Allocated resource blocks		1	1	1	1	1	1	1
Uplink-Downlink Configuration (Note 3)		3+2	3+2	3+2	3+2	3+2	3+2	3+2
Allocated subframes per Radio Frame (D+S)		QPSK	QPSK	QPSK	QPSK	QPSK	QPSK	QPSK
Modulation								
Target Coding Rate								
Information Bit Payload								
For Sub-Frames 4,9 (non CSI-RS subframe)	Bits	NA	NA	NA	NA	NA	NA	NA
For Sub-Frames 4,9	Bits	2600	9144	12216	3496	7992	11832	15840
For Sub-Frames 1,6	Bits	1480	5736	7992	1864	4776	7480	10296
For Sub-Frame 5	Bits	n/a	n/a	n/a	n/a	n/a	n/a	n/a
For Sub-Frame 0	Bits	1736	7736	10680	2344	6456	9912	14112
Number of Code Blocks (Note 4)								
For Sub-Frames 4, 9 (non CSI-RS subframe)	Code blocks	NA	NA	NA	NA	2	NA	NA
For Sub-Frames 4,9	Code blocks	1	2	2	1	2	2	3
For Sub-Frames 1,6	Code blocks	1	1	1	1	1	1	2
For Sub-Frame 5		N/A	N/A	N/A	N/A	N/A	N/A	N/A
For Sub-Frame 0	Code blocks	1	2	2	1	2	2	3
Binary Channel Bits								
For Sub-Frames 4,9	Bits	5100	17100	22800	5100	11800	17100	22800
For Sub-Frames 1,6	Bits	3072	12096	16896	3072	7872	12096	16896
For Sub-Frame 5	Bits	N/A	N/A	N/A	N/A	N/A	N/A	N/A
For Sub-Frame 0	Bits	3456	15120	21120	3456	9840	15120	21120
Max. Throughput averaged over 1 frame	Mbps	0.9896	3.7496	5.1096	1.3064	3.1992	4.8536	6.6384
UE Category		≥ 2	≥ 2	≥ 2	≥ 2	≥ 2	≥ 2	≥ 2

Note 1:	2 symbols allocated to PDCCH for 20 MHz, 15 MHz and 10 MHz channel BW; 3 symbols allocated to PDCCH for 5 MHz and 3 MHz; 4 symbols allocated to PDCCH for 1.4 MHz. For subframe 1&6, only 2 OFDM symbols are allocated to PDCCH.
Note 2:	Reference signal, synchronization signals and PBCH allocated as per TS 36.211 [4].
Note 3:	as per Table 4.2-2 in TS 36.211 [4].
Note 4:	If more than one Code Block is present, an additional CRC sequence of $L = 24$ Bits is attached to each Code Block (otherwise $L = 0$ Bit).
Note 5:	50 resource blocks are allocated in sub-frames 4,9 and 41 resource blocks (RB0–RB20 and RB30–RB49) are allocated in sub-frame 0 and the DwPTS portion of sub-frames 1,6.
Note 6:	25 resource blocks are allocated in sub-frames 4,9 and 17 resource blocks (RB0–RB9 and RB18–RB24) are allocated in sub-frame 0 and the DwPTS portion of sub-frames 1,6.
Note 7:	75 resource blocks are allocated in sub-frames 4,9 and 63 resource blocks (RB0–R31 and RB44–RB74) are allocated in sub-frame 0 and the DwPTS portion of sub-frames 1,6.
Note 8:	100 resource blocks are allocated in sub-frames 4,9 and 88 resource blocks (RB0–RB43 and RB56–RB99) are allocated in sub-frame 0 and the DwPTS portion of sub-frames 1,6.
Note 9:	Given per component carrier per codeword.

## A.3.4.3.4 Four antenna ports (CSI-RS)

The reference measurement channels in Table A.3.4.3.4-1 apply for verifying demodulation performance for CDM-multiplexed UE specific reference symbols with two cell-specific antenna ports and four CSI-RS antenna ports.

**Table A.3.4.3.4-1: Fixed Reference Channel for CDM-multiplexed DM RS with four CSI-RS antenna ports**

Parameter	Unit	Value							
		R.44 TDD	R.48 TDD	R.66 TDD	R.75 TDD	R.75A TDD	R.cc TDD	R.61A TDD	R.102 TDD
Reference channel									
Channel bandwidth	MHz	10	10	20	10	10	10	10	10
Allocated resource blocks		50 (Note 4)	50 (Note 4)	100	50 (Note 4)	50 (Note 4)	50 (Note 4)	50 (Note 4)	50 (Note 4)
Uplink-Downlink Configuration (Note 3)		1	1	1			1	1	1
Allocated subframes per Radio Frame (D+S)		3+2	3+2	3+2	3+2	3+2	3+2	3+2	3+2
Modulation		64QAM	QPSK	256QAM	16QAM	16QAM	16QAM	16QAM	1024QAM
Target Coding Rate		½			0.57	0.51		1/2	3/4
Information Bit Payload									
For Sub-Frames 4,9 (non CSI-RS subframe)	Bits	18336	N/A	N/A	N/A	N/A	N/A	N/A	N/A
For Sub-Frames 4,9 (CSI-RS subframe)	Bits	16416	6200	71112	25456	25456	15264	11448	52752
For Sub-Frames 1,6		11832	4264	48936	16992	16992	9144	7736	31704
For Sub-Frame 5	Bits	N/A	N/A	N/A	N/A	N/A	N/A	N/A	N/A
For Sub-Frame 0	Bits	14688	4968	66592	21384	21384	12576	9528	43816
Number of Code Blocks per Sub-Frame (Note 5)									
For Sub-Frames 4,9 (non CSI-RS subframe)		3	2	N/A	N/A	N/A	N/A	N/A	N/A
For Sub-Frames 4,9 (CSI-RS subframe)		3	2	12	5	5	3	2	9
For Sub-Frames 1,6		2	1	8	3	3	2	2	6
For Sub-Frame 5		N/A	N/A	N/A	N/A	N/A	N/A	N/A	N/A
For Sub-Frame 0		3	1	11	4	4	3	2	7
Binary Channel Bits Per Sub-Frame									
For Sub-Frames 4,9 (non CSI-RS subframe)	Bits	36000	12000	N/A	N/A	N/A	N/A	N/A	N/A
For Sub-Frames 4,9 (CSI-RS subframe)	Bits	33600	11600	89600	40000	44800	22400	22400	64000
For Sub-Frames 1,6		23616	7872	67584	27552	32352	15744	15744	44280
For Sub-Frame 5	Bits	N/A	N/A	N/A	N/A	N/A	N/A	N/A	N/A
For Sub-Frame 0	Bits	29520	9840	84480	35424	40224	19680	19680	54120
Max. Throughput averaged over 1 frame	Mbps	7.1184	2.5896	30.669	10.628	10.628	6.1392	6.1392	21.2728
UE Category		≥ 2	≥ 1	11-12	≥ 5	≥ 5	≥ 2	≥ 2	TBD
UE DL Category		≥ 6	≥ 6	≥ 11	≥ 6	≥ 6	≥ 6	≥ 6	20, ≥ 22
Note 1:	2 symbols allocated to PDCCH. 1 symbol allocated to PDCCH for reference channel with 1024QAM.								
Note 2:	Reference signal, synchronization signals and PBCH allocated as per TS 36.211 [4].								
Note 3:	as per Table 4.2-2 in TS 36.211 [4].								
Note 4:	For R.44,R.48, R.75 and R.cc, 50 resource blocks are allocated in sub-frames 4,9 and 41 resource blocks (RB0–RB20 and RB30–RB49) are allocated in sub-frame 0 and the DwPTS portion of sub-frames 1,6. For R.66, 100 resource blocks are allocated in sub-frames 4, 9 and 88 resources blockes (RB0–RB43 and RB56–RB99) are allocated in sub-frame 0 and the DwPTS portion of sub-frames 1,6.								
Note 5:	If more than one Code Block is present, an additional CRC sequence of L = 24 Bits is attached to each Code Block (otherwise L = 0 Bit).								

The reference measurement channels in Table A.3.4.3.4-2 apply for verifying TDD PMI accuracy measurement with two CRS antenna ports and four CSI-RS antenna ports.

**Table A.3.4.3.4-2: Fixed Reference Channel for four antenna ports (CSI-RS)**

Parameter	Unit	Value		
		R.60 TDD	R.61 TDD	R.61-1 TDD
Reference channel		10	10	10
Channel bandwidth	MHz	10	10	10
Allocated resource blocks		50 <sup>4</sup>	50 <sup>4</sup>	39 <sup>5</sup>
Uplink-Downlink Configuration (Note 3)		1	1	1
Allocated subframes per Radio Frame (D+S)		4+2	4+2	4+2
Allocated subframes per Radio Frame		10	10	10
Modulation		QPSK	16QAM	16QAM
Target Coding Rate		1/2	1/2	1/2
Information Bit Payload				
For Sub-Frames 4 and 9 (Non CSI-RS subframe)	Bits	N/A	N/A	N/A
For Sub-Frames 4 and 9 (CSI-RS subframe)	Bits	6200	11448	8760
For Sub-Frames 1,6	Bits	N/A	7736	7480
For Sub-Frame 5	Bits	N/A	N/A	N/A
For Sub-Frame 0	Bits	N/A	9528	8760
Number of Code Blocks per Sub-Frame (Note 6)				
For Sub-Frames 4 and 9 (Non CSI-RS subframe)		N/A	N/A	N/A
For Sub-Frames 4 and 9 (CSI-RS subframe)		2	2	2
For Sub-Frames 1,6		N/A	2	2
For Sub-Frame 5		N/A	N/A	N/A
For Sub-Frame 0		N/A	2	2
Binary Channel Bits Per Sub-Frame				
For Sub-Frames 4 and 9 (Non CSI-RS subframe)	Bits	N/A	N/A	N/A
For Sub-Frames 4 and 9 (CSI-RS subframe)	Bits	11600	23200	18096
For Sub-Frames 1,6	Bits	N/A	15744	14976
For Sub-Frame 5	Bits	N/A	N/A	N/A
For Sub-Frame 0	Bits	N/A	19680	18720
Max. Throughput averaged over 1 frame	Mbps	1.24	4.7896	4.1240
UE Category		≥ 1	≥ 2	≥ 1
Note 1:	2 symbols allocated to PDCCH for 20 MHz, 15 MHz and 10 MHz channel BW; 3 symbols allocated to PDCCH for 5 MHz and 3 MHz; 4 symbols allocated to PDCCH for 1.4 MHz. For subframe 1&6, only 2 OFDM symbols are allocated to PDCCH.			
Note 2:	Reference signal, synchronization signals and PBCH allocated as per TS 36.211 [4].			
Note 3:	As per Table 4.2-2 in TS 36.211 [4].			
Note 4:	For R. 60 and R.61, 50 resource blocks are allocated in sub-frames 4,9 and 41 resource blocks (RB0–RB20 and RB30–RB49) are allocated in sub-frame 0 and the DwPTS portion of sub-frames 1,6.			
Note 5:	For R. 61-1, 39 resource blocks (RB0–RB20 and RB30–RB47) are allocated in sub-frame 0, 1, 4, 6 and 9.			
Note 6:	If more than one Code Block is present, an additional CRC sequence of L = 24 Bits is attached to each Code Block (otherwise L = 0 Bit).			
Note 7:	Localized allocation started from RB #0 is applied.			

The reference measurement channels in Table A.3.4.3.4-3 apply for verifying demodulation performance for CDM-multiplexed UE specific reference symbols with two cell-specific antenna ports and four CSI-RS antenna ports.

**Table A.3.4.3.4-3: Fixed Reference Channel for CDM-multiplexed DM RS with four CSI-RS antenna ports**

Parameter	Unit	Value
Reference channel		R.64 TDD
Channel bandwidth	MHz	10
Allocated resource blocks (Note 4)		6
Uplink-Downlink Configuration (Note 3)		1
Allocated subframes per Radio Frame (D+S)		4+2
Modulation		QPSK
Target Coding Rate		1/3
Information Bit Payload		
For Sub-Frames 4,9 (non CSI-RS subframe)	Bits	504
For Sub-Frames 4,9 (CSI-RS subframe)	Bits	504
For Sub-Frames 1,6		256
For Sub-Frames 0,5	Bits	504
Number of Code Blocks per Sub-Frame		
For Sub-Frames 4,9 (non CSI-RS subframe)	Code blocks	1
For Sub-Frames 4,9 (CSI-RS subframe)	Code blocks	1
For Sub-Frames 1,6	Code blocks	1
For Sub-Frames 0,5	Code blocks	1
Binary Channel Bits Per Sub-Frame		
For Sub-Frames 4,9 (non CSI-RS subframe)	Bits	1440
For Sub-Frames 4,9 (CSI-RS subframe)	Bits	1352
For Sub-Frames 1,6		1152
For Sub-Frames 0,5	Bits	1440
Max. Throughput averaged over 1 frame	Mbps	0.2528
UE DL Category		0
Note 1:	2 symbols allocated to PDCCH.	
Note 2:	Reference signal, synchronization signals and PBCH allocated as per TS 36.211 [4].	
Note 3:	as per Table 4.2-2 in TS 36.211 [4].	
Note 4:	Allocated PRB positions start from {9, 10, ..., 9+N-1}, where N is the number of allocated resource blocks.	

The reference measurement channels in Table A.3.4.3.4-4 apply for verifying demodulation performance for CDM-multiplexed UE specific reference symbols with two cell-specific antenna ports and four CSI-RS antenna ports.

**Table A.3.4.3.4-4: Fixed Reference Channel for CDM-multiplexed DM RS with four CSI-RS antenna ports**

Parameter	Unit	Value
Reference channel		R.69 TDD
Channel bandwidth	MHz	10
Allocated resource blocks		50 (Note 4)
Uplink-Downlink Configuration (Note 3)		1
Allocated subframes per Radio Frame (D+S)		2+2
Modulation		QPSK
Target Coding Rate		
For Sub-Frame 4(CSI-RS subframe)		0.8
For Sub-Frame 9 (non CSI-RS subframe)		0.74
For Sub-Frames 1,6		0.61
Information Bit Payload		
For Sub-Frame 4(CSI-RS subframe)	Bits	7992
For Sub-Frame 9 (non CSI-RS subframe)	Bits	7992
For Sub-Frames 1,6	Bits	4776
For Sub-Frame 5	Bits	N/A
For Sub-Frame 0	Bits	N/A
Number of Code Blocks per Sub-Frame (Note 5)		
For Sub-Frame 4(CSI-RS subframe)		2
For Sub-Frame 9 (non CSI-RS subframe)		2
For Sub-Frames 1,6		1
For Sub-Frame 5		N/A
For Sub-Frame 0		N/A
Binary Channel Bits Per Sub-Frame		
For Sub-Frame 4(CSI-RS subframe)	Bits	10000
For Sub-Frame 9 (non CSI-RS subframe)	Bits	10800
For Sub-Frames 1,6	Bits	7872
For Sub-Frame 5	Bits	N/A
For Sub-Frame 0	Bits	N/A
Max. Throughput averaged over 1 frame	Mbps	2.5536
UE Category		≥ 1

Note 1: 3 symbols allocated to PDCCH.  
Note 2: Reference signal, synchronization signals and PBCH allocated as per TS 36.211 [4].  
Note 3: As per Table 4.2-2 in TS 36.211 [4].  
Note 4: 50 resource blocks are allocated in sub-frames 4,9 and 41 resource blocks (RB0–RB20 and RB30–RB49) are allocated in the DwPTS portion of sub-frames 1,6.  
Note 5: If more than one Code Block is present, an additional CRC sequence of L = 24 Bits is attached to each Code Block (otherwise L = 0 Bit).

The reference measurement channels in Table A.3.4.3.4-5 apply for verifying CRI reporting accuracy with two cell-specific antenna ports and four CSI-RS antenna ports.

Table A.3.3.3.4-5: Fixed Reference Channel for four antenna ports (CSI-RS)

Parameter	Unit	Value
Reference channel		R.44A-1 TDD
Channel bandwidth	MHz	10
Uplink-Downlink Configuration (Note 3)		2
Allocated resource blocks		50 <sup>4</sup>
Allocated subframes per Radio Frame		4+2
Modulation		64QAM
Target Coding Rate		1/2
Information Bit Payload		
For Sub-Frames (Non CSI-RS subframe)	Bits	18336
For Sub-Frames (CSI-RS subframe)	Bits	N/A
For Sub-Frame 5	Bits	N/A
For Sub-Frames 1,6		11832
For Sub-Frame 0	Bits	14688
Number of Code Blocks per Sub-Frame (Note 5)		
For Sub-Frames (Non CSI-RS subframe)		3
For Sub-Frames (CSI-RS subframe)		N/A
For Sub-Frame 5		N/A
For Sub-Frames 1,6		2
For Sub-Frame 0		3
Binary Channel Bits Per Sub-Frame		
For Sub-Frames (Non CSI-RS subframe)	Bits	36000
For Sub-Frames (CSI-RS subframe)	Bits	N/A
For Sub-Frame 5	Bits	N/A
For Sub-Frames 1,6	Bits	23616
For Sub-Frame 0	Bits	29520
Max. Throughput averaged over 1 frame	Mbps	9.336
UE Category		≥ 2
Note 1:	2 symbols allocated to PDCCH for 20 MHz, 15 MHz and 10 MHz channel BW; 3 symbols allocated to PDCCH for 5 MHz and 3 MHz; 4 symbols allocated to PDCCH for 1.4 MHz	
Note 2:	Reference signal, synchronization signals and PBCH allocated as per TS 36.211 [4]	
Note 3:	As per Table 4.2-2 in TS 36.211 [4].	
Note 4:	For R.44A-1, 50 resource blocks are allocated in sub-frames 3, 8, 9 and 41 resource blocks (RB0–RB20 and RB30–RB49) are allocated in sub-frame 0 and the DwPTS portion of sub-frames 1,6.	
Note 5:	If more than one Code Block is present, an additional CRC sequence of L = 24 Bits is attached to each Code Block (otherwise L = 0 Bit)	

The reference measurement channels in Table A.3.4.3.4-6 apply with two CRS antenna ports and four CSI-RS antenna ports.

**Table A.3.4.3.4-6: Fixed Reference Channel for CDM-multiplexed DM RS with four CSI-RS antenna ports with ZP CSI-RS and NZP CSI-RS**

Parameter	Unit	Value	
Reference channel		R.98 TDD	R.99 TDD
Channel bandwidth	MHz	10	10
Allocated resource blocks		50 (Note 5)	50 (Note 5)
Uplink-Downlink Configuration (Note 3)		1	1
Allocated subframes per Radio Frame (D+S)		3+2	3+2
Modulation		16QAM	16QAM
Target Coding Rate		1/2	1/2
Information Bit Payload			
For Sub-Frame 4,9	Bits	22920	11448
For Sub-Frames 1,6	Bits	14112	6712
For Sub-Frame 5	Bits	n/a	n/a
For Sub-Frame 0	Bits	19080	9528
Number of Code Blocks (Note 4)			
For Sub-Frames 4,9	Code blocks	4	2
For Sub-Frames 1,6	Code blocks	3	2
For Sub-Frame 5		n/a	n/a
For Sub-Frame 0	Code blocks	4	2
Binary Channel Bits			
For Sub-Frames 4,9		38400	19200
For Sub-Frames 1,6		27552	13776
For Sub-Frame 5	Bits	n/a	n/a
For Sub-Frame 0	Bits	35424	17712
Max. Throughput averaged over 1 frame	Mbps	9.3144	4.5848
UE Category		≥ 2	≥ 2
Note 1:	2 symbols allocated to PDCCH.		
Note 2:	Reference signal, synchronization signals and PBCH allocated as per TS 36.211 [4].		
Note 3:	as per Table 4.2-2 in TS 36.211 [4].		
Note 4:	If more than one Code Block is present, an additional CRC sequence of L = 24 Bits is attached to each Code Block (otherwise L = 0 Bit).		
Note 5:	50 resource blocks are allocated in sub-frames 4, 9 and 41 resource blocks (RB0–RB20 and RB30–RB49) are allocated in sub-frame 0 and the DwPTS portion of sub-frames 1, 6.		

The reference measurement channels in Table A.3.4.3.4-7 apply with four CRS antenna ports and four CSI-RS antenna ports.



**Table A.3.4.3.4-7: Fixed Reference Channel for CDM-multiplexed DM RS with four CSI-RS antenna ports with ZP CSI-RS and NZP CSI-RS**

Parameter	Unit	Value
Reference channel		R.100 TDD
Channel bandwidth	MHz	10
Allocated resource blocks		50 (Note 5)
Uplink-Downlink Configuration (Note 3)		1
Allocated subframes per Radio Frame (D+S)		3+2
Modulation		16QAM
Target Coding Rate		1/2
Information Bit Payload		
For Sub-Frame 4,9	Bits	22920
For Sub-Frames 1,6	Bits	14112
For Sub-Frame 5	Bits	n/a
For Sub-Frame 0	Bits	19080
Number of Code Blocks (Note 4)		
For Sub-Frames 4,9	Code blocks	4
For Sub-Frames 1,6	Code blocks	3
For Sub-Frame 5		n/a
For Sub-Frame 0	Code blocks	4
Binary Channel Bits		
For Sub-Frames 4,9		36800
For Sub-Frames 1,6		26240
For Sub-Frame 5	Bits	n/a
For Sub-Frame 0	Bits	34112
Max. Throughput averaged over 1 frame	Mbps	9.3144
UE Category		≥ 2
Note 1:	2 symbols allocated to PDCCH.	
Note 2:	Reference signal, synchronization signals and PBCH allocated as per TS 36.211 [4].	
Note 3:	as per Table 4.2-2 in TS 36.211 [4].	
Note 4:	If more than one Code Block is present, an additional CRC sequence of L = 24 Bits is attached to each Code Block (otherwise L = 0 Bit).	
Note 5:	50 resource blocks are allocated in sub-frames 4, 9 and 41 resource blocks (RB0–RB20 and RB30–RB49) are allocated in sub-frame 0 and the DwPTS portion of sub-frames 1, 6.	

## A.3.4.3.5 Eight antenna ports (CSI-RS)

The reference measurement channels in Table A.3.4.3.5-1 apply for verifying demodulation performance for CDM-multiplexed UE specific reference symbols with two cell-specific antenna ports and eight CSI-RS antenna ports.

Table A.3.4.3.5-1: Fixed Reference Channel for CDM-multiplexed DM RS with eight CSI-RS antenna ports

Parameter	Unit	Value						
		R.50 TDD	R.50-1 TDD	R.50-2 TDD	R.50-3 TDD	R.50-4 TDD	R.50-5 TDD	R.50-6 TDD
Reference channel		10	10	10	5	10	15	20
Channel bandwidth	MHz	50 (Note 4)	50 (Note 4)	50 (Note 6)	25 (Note 7)	50 (Note 4)	75 (Note 8)	100 (Note 9)
Allocated resource blocks		1	1	1	1	1	1	1
Uplink-Downlink Configuration (Note 3)		3+2	3+2	3+2	3+2	3+2	3+2	3+2
Allocated subframes per Radio Frame (D+S)		QPSK	QPSK	QPSK	16QAM	16QAM	16QAM	16QAM
Modulation		1/3	1/3	1/3	1/2	1/2	1/2	1/2
Target Coding Rate								
Information Bit Payload								
For Sub-Frames 4,9 (non CSI-RS subframe)	Bits	3624	3624	3624	N/A	N/A	N/A	N/A
For Sub-Frames 4,9 (CSI-RS subframe)	Bits	3624	3624	3624	17568	39232	61664	78704
For Sub-Frames 1,6		2664	2664	3112	12216	26416	42368	61664
For Sub-Frame 5	Bits	N/A	N/A	N/A	N/A	N/A	N/A	N/A
For Sub-Frame 0	Bits	2984	2984	3368	13536	37888	57336	78704
Number of Code Blocks per Sub-Frame (Note 5)								
For Sub-Frames 4,9 (non CSI-RS subframe)		1	1	1	N/A	N/A	N/A	N/A
For Sub-Frames 4,9 (CSI-RS subframe)		1	1	1	3	7	11	13
For Sub-Frames 1,6		1	1	1	2	5	7	11
For Sub-Frame 5		N/A	N/A	N/A	N/A	N/A	N/A	N/A
For Sub-Frame 0		1	1	1	3	7	10	13
Binary Channel Bits Per Sub-Frame								
For Sub-Frames 4,9 (non CSI-RS subframe)	Bits	12000	13200	13200	N/A	N/A	N/A	N/A
For Sub-Frames 4,9 (CSI-RS subframe)	Bits	10400	11600	11600	33600	76800	115200	153600
For Sub-Frames 1,6		7872	7872	8448	22848	55104	84672	118272
For Sub-Frame 5	Bits	N/A	N/A	N/A	N/A	N/A	N/A	N/A
For Sub-Frame 0	Bits	9840	9840	10560	26112	70848	108864	152064

Max. Throughput averaged over 1 frame	Mbps	1.556	1.556	1.684	7.3104	16.9184	26.54	35.944
UE Category		≥ 1	≥ 1	≥ 1	8	8	8	8
UE DL Category					14, 17,18,19,20,22, 23,24,25,26	14, 17,18,19,20,22, 23,24,25,26	14, 17,18,19,20,22, 23,24,25,26	14, 17,18,19,20,22, 23,24,25,26
<p>Note 1: 2 symbols allocated to PDCCH.</p> <p>Note 2: Reference signal, synchronization signals and PBCH allocated as per TS 36.211 [4].</p> <p>Note 3: as per Table 4.2-2 in TS 36.211 [4].</p> <p>Note 4: 50 resource blocks are allocated in sub-frames 4,9 and 41 resource blocks (RB0–RB20 and RB30–RB49) are allocated in sub-frame 0 and the DwPTS portion of sub-frames 1,6.</p> <p>Note 5: If more than one Code Block is present, an additional CRC sequence of L = 24 Bits is attached to each Code Block (otherwise L = 0 Bit).</p> <p>Note 6: 50 resource blocks are allocated in sub-frames 4,9 and 47 resource blocks (RB0–RB23 and RB27–RB49) are allocated in sub-frame 0 and the DwPTS portion of sub-frames 1,6. In sub-frame 0 and the DwPTS portion of sub-frames 1, 6, PDSCH is rate matched around RB22, RB23 and RB27.</p> <p>Note 7: 25 resource blocks are allocated in sub-frames 4,9 and 17 resource blocks (RB0–RB9 and RB18–RB24) are allocated in sub-frame 0 and the DwPTS portion of sub-frames 1,6.</p> <p>Note 8: 75 resource blocks are allocated in sub-frames 4,9 and 63 resource blocks (RB0–R31 and RB44–RB74) are allocated in sub-frame 0 and the DwPTS portion of sub-frames 1,6.</p> <p>Note 9: 100 resource blocks are allocated in sub-frames 4,9 and 88 resource blocks (RB0–RB43 and RB56–RB99) are allocated in sub-frame 0 and the DwPTS portion of sub-frames 1,6.</p> <p>Note 10: Given per component carrier per codeword.</p>								

The reference measurement channels in Table A.3.4.3.5-2 apply for verifying TDD PMI accuracy measurement with two CRS antenna ports and eight CSI-RS antenna ports.

Table A.3.4.3.5-2: Fixed Reference Channel for eight antenna ports (CSI-RS)

Parameter	Unit	Value			
		R.45 TDD	R.45-1 TDD	R.45-2 TDD	R.45A TDD
Reference channel					
Channel bandwidth	MHz	10	10	10	10
Allocated resource blocks		50 <sup>4</sup>	39	50 <sup>4</sup>	50 <sup>4</sup>
Uplink-Downlink Configuration (Note 3)		1	1	1	1
Allocated subframes per Radio Frame (D+S)		4+2	4+2	4+2	4+2
Allocated subframes per Radio Frame		5	5	10	5
Modulation		16QAM	16QAM	64QAM	16QAM
Target Coding Rate		1/2	1/2		1/2
Information Bit Payload					
For Sub-Frames 4 and 9 (Non CSI-RS subframe)	Bits	N/A	N/A	N/A	N/A
For Sub-Frames 4 and 9 (CSI-RS subframe)	Bits	11448	8760	[18336]	11448
For Sub-Frames 1,6	Bits	7736	7480	[11832]	7736
For Sub-Frame 5	Bits	N/A	N/A	N/A	N/A
For Sub-Frame 0	Bits	9528	8760	[14688]	9528
Number of Code Blocks per Sub-Frame (Note 5)					
For Sub-Frames 4 and 9 (Non CSI-RS subframe)		N/A	N/A	N/A	N/A
For Sub-Frames 4 and 9 (CSI-RS subframe)		2	2		2
For Sub-Frames 1,6		2	2		2
For Sub-Frame 5		N/A	N/A		N/A
For Sub-Frame 0		2	2		2
Binary Channel Bits Per Sub-Frame					
For Sub-Frames 4 and 9 (Non CSI-RS subframe)	Bits	N/A	N/A		N/A
For Sub-Frames 4 and 9 (CSI-RS subframe)	Bits	22400	17472	[33600]	23200
For Sub-Frames 1,6	Bits	15744	14976	[23616]	15744
For Sub-Frame 5	Bits	N/A	N/A	N/A	N/A
For Sub-Frame 0	Bits	19680	18720	[29520]	19680
Max. Throughput averaged over 1 frame	Mbps	4.7896	4.1240	7.3296	4.7896
UE Category		≥ 2	≥ 1	≥ 2	≥ 2
Note 1:	2 symbols allocated to PDCCH for 20 MHz, 15 MHz and 10 MHz channel BW; 3 symbols allocated to PDCCH for 5 MHz and 3 MHz; 4 symbols allocated to PDCCH for 1.4 MHz. For subframe 1&6, only 2 OFDM symbols are allocated to PDCCH.				
Note 2:	Reference signal, synchronization signals and PBCH allocated as per TS 36.211 [4].				
Note 3:	As per Table 4.2-2 in TS 36.211 [4].				
Note 4:	For R.45 and R.45-2, 50 resource blocks are allocated in sub-frames 4,9 and 41 resource blocks (RB0–RB20 and RB30–RB49) are allocated in sub-frame 0 and the DwPTS portion of sub-frames 1,6. For R.45-1, 39 resource blocks are allocated in sub-frames 0,4,9 and the DwPTS portion of sub-frames 1,6 (RB0–RB20 and RB30–RB47).				
Note 5:	If more than one Code Block is present, an additional CRC sequence of L = 24 Bits is attached to each Code Block (otherwise L = 0 Bit).				
Note 6:	Localized allocation started from RB #0 is applied.				

The reference measurement channels in Table A.3.4.3.5-3 apply for verifying CRI reporting accuracy with two cell-specific antenna ports and four CSI-RS antenna ports.

Table A.3.4.3.5-3: Fixed Reference Channel for eight antenna ports (CSI-RS)

Parameter	Unit	Value	
		R.44A-2 TDD	R.44A-3 TDD
Reference channel		R.44A-2 TDD	R.44A-3 TDD
Channel bandwidth	MHz	10	10
Uplink-Downlink Configuration (Note 3)		2	2
Allocated resource blocks		50 <sup>4</sup>	50 <sup>4</sup>
Allocated subframes per Radio Frame		4+2	3+2
Modulation		64QAM	64QAM
Target Coding Rate		1/2	1/2
Information Bit Payload			
For Sub-Frames (Non CSI-RS subframe)	Bits	18336	18336
For Sub-Frames (CSI-RS subframe)	Bits	N/A	N/A
For Sub-Frame 5	Bits	N/A	N/A
For Sub-Frames 1,6		11832	11832
For Sub-Frame 0	Bits	14688	14688
Number of Code Blocks per Sub-Frame (Note 5)			
For Sub-Frames (Non CSI-RS subframe)		3	3
For Sub-Frames (CSI-RS subframe)		N/A	N/A
For Sub-Frame 5		N/A	N/A
For Sub-Frames 1,6		2	2
For Sub-Frame 0		3	3
Binary Channel Bits Per Sub-Frame			
For Sub-Frames (Non CSI-RS subframe)	Bits	36000	36000
For Sub-Frames (CSI-RS subframe)	Bits	N/A	N/A
For Sub-Frame 5	Bits	N/A	N/A
For Sub-Frames 1,6	Bits	23616	23616
For Sub-Frame 0	Bits	29520	29520
Max. Throughput averaged over 1 frame	Mbps	9.336	7.5024
UE Category		≥ 2	≥ 2
Note 1:	2 symbols allocated to PDCCH for 20 MHz, 15 MHz and 10 MHz channel BW; 3 symbols allocated to PDCCH for 5 MHz and 3 MHz; 4 symbols allocated to PDCCH for 1.4 MHz		
Note 2:	Reference signal, synchronization signals and PBCH allocated as per TS 36.211 [4]		
Note 3:	As per Table 4.2-2 in TS 36.211 [4].		
Note 4:	For R.44A-2, 50 resource blocks are allocated in sub-frames 3, 8, 9 and 41 resource blocks (RB0–RB20 and RB30–RB49) are allocated in sub-frame 0 and the DwPTS portion of sub-frames 1,6. For R.44A-3, 50 resource blocks are allocated in sub-frames 8, 9 and 41 resource blocks (RB0–RB20 and RB30–RB49) are allocated in sub-frame 0 and the DwPTS portion of sub-frames 1,6.		
Note 5:	If more than one Code Block is present, an additional CRC sequence of L = 24 Bits is attached to each Code Block (otherwise L = 0 Bit)		

Table A.3.4.3.5-4: Fixed Reference Channel for eight antenna ports (CSI-RS)

Parameter	Unit	Value
Reference channel		R.108 TDD
Channel bandwidth	MHz	10
Uplink-Downlink Configuration (Note 3)		2
Allocated resource blocks		4 <sup>4</sup>
Allocated subframes per Radio Frame		4
Modulation		QPSK
Target Coding Rate		1/2
Information Bit Payload		
For Sub-Frames 0,5 (Non CSI-RS subframe)	Bits	472
For Sub-Frames 4,9 (CSI-RS subframe)	Bits	472
For Sub-Frames 1,6		N/A
Number of Code Blocks per Sub-Frame (Note 5)		
For Sub-Frames 0,5 (Non CSI-RS subframe)		1
For Sub-Frames 4,9 (CSI-RS subframe)		1
For Sub-Frames 1,6		N/A
Binary Channel Bits Per Sub-Frame		
For Sub-Frames 0,5 (Non CSI-RS subframe)	Bits	960
For Sub-Frames 4,9 (CSI-RS subframe)	Bits	896
For Sub-Frames 1,6		N/A
Max. Throughput averaged over 1 frame	Mbps	0.1888
UE Category		≥ 1
Note 1:	2 symbols allocated to PDCCH.	
Note 2:	Reference signal, synchronization signals and PBCH allocated as per TS 36.211 [4]	
Note 3:	As per Table 4.2-2 in TS 36.211 [4].	
Note 4:	Allocated PRB positions for PDSCH are {2, 3, 4, 5} within the assigned narrowband. Allocated PRB positions for MPDCCH are {0, 1} within the assigned narrowband.	
Note 5:	If more than one Code Block is present, an additional CRC sequence of L = 24 Bits is attached to each Code Block (otherwise L = 0 Bit)	

#### A.3.4.3.6 Twelve antenna ports (CSI-RS)

The reference measurement channels in Table A.3.4.3.6-1 apply for verifying TDD PMI accuracy measurement with two CRS antenna ports and twelve CSI-RS antenna ports.

Table A.3.4.3.6-1: Fixed Reference Channel for twelve antenna ports (CSI-RS)

Parameter	Unit	Value
Reference channel		R.77 TDD
Channel bandwidth	MHz	10
Allocated resource blocks		50 <sup>4</sup>
Uplink-Downlink Configuration (Note 3)		1
Allocated subframes per Radio Frame (D+S)		3+2
Allocated subframes per Radio Frame		10
Modulation		64QAM
Target Coding Rate		1/2
Information Bit Payload		
For Sub-Frames 4 and 9 (Non CSI-RS subframe)	Bits	N/A
For Sub-Frames 4 and 9 (CSI-RS subframe)	Bits	16416
For Sub-Frames 1,6	Bits	11832
For Sub-Frame 5	Bits	N/A
For Sub-Frame 0	Bits	14688
Number of Code Blocks per Sub-Frame (Note 5)		
For Sub-Frames 4 and 9 (Non CSI-RS subframe)		N/A
For Sub-Frames 4 and 9 (CSI-RS subframe)		3
For Sub-Frames 1,6		2
For Sub-Frame 5		N/A
For Sub-Frame 0		3
Binary Channel Bits Per Sub-Frame		
For Sub-Frames 4 and 9 (Non CSI-RS subframe)	Bits	N/A
For Sub-Frames 4 and 9 (CSI-RS subframe)	Bits	32400
For Sub-Frames 1,6	Bits	23616
For Sub-Frame 5	Bits	N/A
For Sub-Frame 0	Bits	29520
Max. Throughput averaged over 1 frame	Mbps	7.1184
UE Category		≥ 2
Note 1:	2 symbols allocated to PDCCH for 20 MHz, 15 MHz and 10 MHz channel BW; 3 symbols allocated to PDCCH for 5 MHz and 3 MHz; 4 symbols allocated to PDCCH for 1.4 MHz. For subframe 1&6, only 2 OFDM symbols are allocated to PDCCH.	
Note 2:	Reference signal, synchronization signals and PBCH allocated as per TS 36.211 [4].	
Note 3:	As per Table 4.2-2 in TS 36.211 [4].	
Note 4:	50 resource blocks are allocated in sub-frames 4,9 and 41 resource blocks (RB0–RB20 and RB30–RB49) are allocated in sub-frame 0 and the DwPTS portion of sub-frames 1,6.	
Note 5:	If more than one Code Block is present, an additional CRC sequence of L = 24 Bits is attached to each Code Block (otherwise L = 0 Bit).	
Note 6:	Localized allocation started from RB #0 is applied.	

#### A.3.4.3.7 Sixteen antenna ports (CSI-RS)

The reference measurement channels in Table A.3.4.3.7-1 apply for verifying TDD PMI accuracy measurement with two CRS antenna ports and sixteen CSI-RS antenna ports.

Table A.3.4.3.7-1: Fixed Reference Channel for sixteen antenna ports (CSI-RS)

Parameter	Unit	Value
Reference channel		R.78 TDD
Channel bandwidth	MHz	10
Allocated resource blocks		50 <sup>4</sup>
Uplink-Downlink Configuration (Note 3)		1
Allocated subframes per Radio Frame (D+S)		3+2
Allocated subframes per Radio Frame		10
Modulation		16QAM
Target Coding Rate		1/2
Information Bit Payload		
For Sub-Frames 4 and 9 (Non CSI-RS subframe)	Bits	N/A
For Sub-Frames 4 and 9 (CSI-RS subframe)	Bits	9912
For Sub-Frames 1,6	Bits	7736
For Sub-Frame 5	Bits	N/A
For Sub-Frame 0	Bits	9528
Number of Code Blocks per Sub-Frame (Note 5)		
For Sub-Frames 4 and 9 (Non CSI-RS subframe)		N/A
For Sub-Frames 4 and 9 (CSI-RS subframe)		2
For Sub-Frames 1,6		2
For Sub-Frame 5		N/A
For Sub-Frame 0		2
Binary Channel Bits Per Sub-Frame		
For Sub-Frames 4 and 9 (Non CSI-RS subframe)	Bits	N/A
For Sub-Frames 4 and 9 (CSI-RS subframe)	Bits	20800
For Sub-Frames 1,6	Bits	15744
For Sub-Frame 5	Bits	N/A
For Sub-Frame 0	Bits	19680
Max. Throughput averaged over 1 frame	Mbps	4.4824
UE Category		≥ 2
Note 1:	2 symbols allocated to PDCCH for 20 MHz, 15 MHz and 10 MHz channel BW; 3 symbols allocated to PDCCH for 5 MHz and 3 MHz; 4 symbols allocated to PDCCH for 1.4 MHz. For subframe 1&6, only 2 OFDM symbols are allocated to PDCCH.	
Note 2:	Reference signal, synchronization signals and PBCH allocated as per TS 36.211 [4].	
Note 3:	As per Table 4.2-2 in TS 36.211 [4].	
Note 4:	50 resource blocks are allocated in sub-frames 4,9 and 41 resource blocks (RB0–RB20 and RB30–RB49) are allocated in sub-frame 0 and the DwPTS portion of sub-frames 1,6.	
Note 5:	If more than one Code Block is present, an additional CRC sequence of L = 24 Bits is attached to each Code Block (otherwise L = 0 Bit).	
Note 6:	Localized allocation started from RB #0 is applied.	

#### A.3.4.3.8 Twenty-four antenna ports (CSI-RS)

The reference measurement channels in Table A.3.4.3.8-1 apply for verifying TDD PMI accuracy measurement with two CRS antenna ports and twenty-four CSI-RS antenna ports.



Table A.3.4.3.8-1: Fixed Reference Channel for twenty-four antenna ports (CSI-RS)

Parameter	Unit	Value	
		R.88 TDD	R.88A TDD
Reference channel		R.88 TDD	R.88A TDD
Channel bandwidth	MHz	10	10
Allocated resource blocks		50 <sup>4</sup>	50 <sup>4</sup>
Uplink-Downlink Configuration (Note 3)		1	1
Allocated subframes per Radio Frame (D+S)		3+2	3+2
Allocated subframes per Radio Frame		10	10
Modulation		16QAM	16QAM
Target Coding Rate		1/2	1/2
Information Bit Payload			
For Sub-Frames 4 and 9 (Non CSI-RS subframe)	Bits	N/A	N/A
For Sub-Frames 4 and 9 (CSI-RS subframe)	Bits	9912	11448
For Sub-Frames 1,6	Bits	7736	7736
For Sub-Frame 5	Bits	N/A	N/A
For Sub-Frame 0	Bits	9528	9528
Number of Code Blocks per Sub-Frame (Note 5)			
For Sub-Frames 4 and 9 (Non CSI-RS subframe)		N/A	N/A
For Sub-Frames 4 and 9 (CSI-RS subframe)		2	2
For Sub-Frames 1,6		2	2
For Sub-Frame 5		N/A	N/A
For Sub-Frame 0		2	2
Binary Channel Bits Per Sub-Frame			
For Sub-Frames 4 and 9 (Non CSI-RS subframe)	Bits	N/A	N/A
For Sub-Frames 4 and 9 (CSI-RS subframe)	Bits	19200	22400
For Sub-Frames 1,6	Bits	15744	15744
For Sub-Frame 5	Bits	N/A	N/A
For Sub-Frame 0	Bits	19680	19680
Max. Throughput averaged over 1 frame	Mbps	4.4824	4.7896
UE Category		≥ 2	≥ 2
Note 1:	2 symbols allocated to PDCCH for 20 MHz, 15 MHz and 10 MHz channel BW; 3 symbols allocated to PDCCH for 5 MHz and 3 MHz; 4 symbols allocated to PDCCH for 1.4 MHz. For subframe 1&6, only 2 OFDM symbols are allocated to PDCCH.		
Note 2:	Reference signal, synchronization signals and PBCH allocated as per TS 36.211 [4].		
Note 3:	As per Table 4.2-2 in TS 36.211 [4].		
Note 4:	50 resource blocks are allocated in sub-frames 4,9 and 41 resource blocks (RB0–RB20 and RB30–RB49) are allocated in sub-frame 0 and the DwPTS portion of sub-frames 1,6.		
Note 5:	If more than one Code Block is present, an additional CRC sequence of L = 24 Bits is attached to each Code Block (otherwise L = 0 Bit).		
Note 6:	Localized allocation started from RB #0 is applied.		

#### A.3.4.3.9 Thirty-two antenna ports (CSI-RS)

The reference measurement channels in Table A.3.4.3.9-1 apply for verifying TDD PMI accuracy measurement with two CRS antenna ports and thirty-two CSI-RS antenna ports.

Table A.3.4.3.9-1: Fixed Reference Channel for thirty-two antenna ports (CSI-RS)

Parameter	Unit	Value
Reference channel		R.89 TDD
Channel bandwidth	MHz	10
Allocated resource blocks		50 <sup>4</sup>
Uplink-Downlink Configuration (Note 3)		1
Allocated subframes per Radio Frame (D+S)		3+2
Allocated subframes per Radio Frame		10
Modulation		64QAM
Target Coding Rate		1/2
Information Bit Payload		
For Sub-Frames 4 and 9 (Non CSI-RS subframe)	Bits	N/A
For Sub-Frames 4 and 9 (CSI-RS subframe)	Bits	15264
For Sub-Frames 1,6	Bits	11832
For Sub-Frame 5	Bits	N/A
For Sub-Frame 0	Bits	14688
Number of Code Blocks per Sub-Frame (Note 5)		
For Sub-Frames 4 and 9 (Non CSI-RS subframe)		N/A
For Sub-Frames 4 and 9 (CSI-RS subframe)		3
For Sub-Frames 1,6		2
For Sub-Frame 5		N/A
For Sub-Frame 0		3
Binary Channel Bits Per Sub-Frame		
For Sub-Frames 4 and 9 (Non CSI-RS subframe)	Bits	N/A
For Sub-Frames 4 and 9 (CSI-RS subframe)	Bits	26400
For Sub-Frames 1,6	Bits	23616
For Sub-Frame 5	Bits	N/A
For Sub-Frame 0	Bits	29520
Max. Throughput averaged over 1 frame	Mbps	6.888
UE Category		≥ 2
Note 1:	2 symbols allocated to PDCCH for 20 MHz, 15 MHz and 10 MHz channel BW; 3 symbols allocated to PDCCH for 5 MHz and 3 MHz; 4 symbols allocated to PDCCH for 1.4 MHz. For subframe 1&6, only 2 OFDM symbols are allocated to PDCCH.	
Note 2:	Reference signal, synchronization signals and PBCH allocated as per TS 36.211 [4].	
Note 3:	As per Table 4.2-2 in TS 36.211 [4].	
Note 4:	50 resource blocks are allocated in sub-frames 4,9 and 41 resource blocks (RB0–RB20 and RB30–RB49) are allocated in sub-frame 0 and the DwPTS portion of sub-frames 1,6.	
Note 5:	If more than one Code Block is present, an additional CRC sequence of L = 24 Bits is attached to each Code Block (otherwise L = 0 Bit).	
Note 6:	Localized allocation started from RB #0 is applied.	

## A.3.5 Reference measurement channels for PDCCH/PCFICH performance requirements

### A.3.5.1 FDD

**Table A.3.5.1-1: Reference Channel FDD**

Parameter	Unit	Value											
		R.15 FDD	R.15 -1 FDD	R.15 -2 FDD	R.16 6 FDD	R.16 -1 FDD	R.16 -2 FDD	R.16 -3 FDD	R.16 -4 FDD	R.17 7 FDD	R.17 -1 FDD	R.17 -2 FDD	R.17 -3 FDD
Number of transmitter antennas		1	2	2	2	2	2	2	2	2	4	4	4
Channel bandwidth	MHz	10	10	10	10	10	10	10	10	5	10	10	10
Number of OFDM symbols for PDCCH	symbols	2	3	2	2	3	3	1	1	2	2	2	2
Aggregation level	CCE	8	8	8	4	2	4	2	4	2	2	1	4
DCI Format		1	1	1	2	2	2	2	2	2	2	2	2
Cell ID		0	0	0	0	0	0	0	0	0	0	0	0
Payload (without CRC)	Bits	31	31	31	43	43	43	43	43	42	46	46	46

**Table A.3.5.1-2: Void**

### A.3.5.2 TDD

**Table A.3.5.2-1: Reference Channel TDD**

Parameter	Unit	Value											
		R.15 TDD	R.15 -1 TDD	R.15 -2 TDD	R.16 6 TDD	R.16 -1 TDD	R.16 -2 TDD	R.16 -3 TDD	R.16 -4 TDD	R.17 7 TDD	R.17 -1 TDD	R.17 -2 TDD	R.17 -3 TDD
Number of transmitter antennas		1	2	2	2	2	2	2	2	4	4	4	4
Channel bandwidth	MHz	10	10	10	10	10	10	10	10	5	10	10	10
Number of OFDM symbols for PDCCH	symbols	2	3	2	2	3	3	1	1	2	2	2	2
Aggregation level	CCE	8	8	8	4	2	4	2	4	2	2	1	4
DCI Format		1	1	1	2	2	2	2	2	2	2	2	2
Cell ID		0	0	0	0	0	0	0	0	0	0	0	0
Payload (without CRC)	Bits	34	34	34	46	46	46	46	46	45	49	49	49

**Table A.3.5.2-2: Void**

### A.3.5.3 LAA

**Table A.3.5.3-1: Reference Channel for FS3 with FDD primary cell**

Parameter	Unit	Value
Reference channel		R.3 FS3
Number of transmitter antennas		2
Channel bandwidth	MHz	20
Number of OFDM symbols for PDCCH	symbols	2
Aggregation level	CCE	4
DCI Format		Format 2A
Cell ID		0
Payload (without CRC)	Bits	48

**Table A.3.5.3-2: Reference Channel for FS3 with TDD primary cell**

Parameter	Unit	Value
Reference channel		R.4 FS3
Number of transmitter antennas		2
Channel bandwidth	MHz	20
Number of OFDM symbols for PDCCH	symbols	2
Aggregation level	CCE	4
DCI Format		Format 2A
Cell ID		0
Payload (without CRC)	Bits	51

### A.3.6 Reference measurement channels for PHICH performance requirements

**Table A.3.6-1: Reference Channel FDD/TDD**

Parameter	Unit	Value				
		R.18	R.19	R.19-1	R.20	R.24
Reference channel		1	2	2	4	1
Number of transmitter antennas		1	2	2	4	1
Channel bandwidth	MHz	10	10	5	5	10
User roles (Note 1)		W I1 I2	W I1 I2	W I1 I2	W I1 I2	W I1
Resource allocation (Note 2)		(0,0) (0,1) (0,4)	(0,0) (0,1) (0,4)	(0,0) (0,1) (0,4)	(0,0) (0,1) (0,4)	(0,0) (0,1) (0,4)
Power offsets (Note 3)	dB	-4 0 -3	-4 0 -3	-4 0 -3	-4 0 -3	+3 0
Payload (Note 4)		A R R	A R R	A R R	A R R	A R

Note 1: W=wanted user, I1=interfering user 1, I2=interfering user 2.  
Note 2: The resource allocation per user is given as (N\_group\_PHICH, N\_seq\_PHICH).  
Note 3: The power offsets (per user) represent the difference of the power of BPSK modulated symbol per PHICH relative to the first interfering user.  
Note 4: A=fixed ACK, R=random ACK/NACK.

### A.3.7 Reference measurement channels for PBCH performance requirements

Table A.3.7-1: Reference Channel FDD/TDD

Parameter	Unit	Value			
		R.21	R.22	R.23	R.23-1
Reference channel		R.21	R.22	R.23	R.23-1
Number of transmitter antennas		1	2	4	1
Channel bandwidth	MHz	1.4	1.4	1.4	1.4
Modulation		QPSK	QPSK	QPSK	QPSK
Target coding rate		40/1920	40/1920	40/1920	40/4416
Payload (without CRC)	Bits	24	24	24	24

## A.3.8 Reference measurement channels for MBMS performance requirements

### A.3.8.1 FDD

Table A.3.8.1-1: Fixed Reference Channel QPSK R=1/3

Parameter	Unit	PMCH					
		R.40 FDD			R.37 FDD		
Reference channel							
Channel bandwidth	MHz	1.4	3	5	10	15	20
Allocated resource blocks		6			50		
Allocated subframes per Radio Frame (Note 1)		6			6		
Modulation		QPSK			QPSK		
Target Coding Rate		1/3			1/3		
Information Bit Payload (Note 2)							
For Sub-Frames 1,2,3,6,7,8	Bits	408			3624		
For Sub-Frames 0,4,5,9	Bits	N/A			N/A		
Number of Code Blocks per Subframe (Note 3)		1			1		
Binary Channel Bits Per Subframe							
For Sub-Frames 1,2,3,6,7,8	Bits	1224			10200		
For Sub-Frames 0,4,5,9	Bits	N/A			N/A		
MBMS UE Category		≥ 1			≥ 1		
Note 1:	For FDD mode, up to 6 subframes (#1/2/3/6/7/8) are available for MBMS, in line with TS 36.331.						
Note 2:	2 OFDM symbols are reserved for PDCCH; and reference signal allocated as per TS 36.211.						
Note 3:	If more than one Code Block is present, an additional CRC sequence of L = 24 Bits is attached to each Code Block (otherwise L = 0 Bit).						

Table A.3.8.1-2: Fixed Reference Channel 16QAM R=1/2

Parameter	PMCH						
	Unit	Value					
Reference channel					R.38 FDD		
Channel bandwidth	MHz	1.4	3	5	10	15	20
Allocated resource blocks					50		
Allocated subframes per Radio Frame (Note 1)					6		
Modulation					16QAM		
Target Coding Rate					1/2		
Information Bit Payload (Note 2)							
For Sub-Frames 1,2,3,6,7,8	Bits				9912		
For Sub-Frames 0,4,5,9	Bits				N/A		
Number of Code Blocks per Subframe (Note 3)					2		
Binary Channel Bits Per Subframe							
For Sub-Frames 1,2,3,6,7,8	Bits				20400		
For Sub-Frames 0,4,5,9	Bits				N/A		
MBMS UE Category					$\geq 1$		
Note 1:	For FDD mode, up to 6 subframes (#1/2/3/6/7/8) are available for MBMS, in line with TS 36.331.						
Note 2:	2 OFDM symbols are reserved for PDCCH; and reference signal allocated as per TS 36.211.						
Note 3:	If more than one Code Block is present, an additional CRC sequence of L = 24 Bits is attached to each Code Block (otherwise L = 0 Bit).						

Table A.3.8.1-3: Fixed Reference Channel 64QAM R=2/3

Parameter	PMCH						
	Unit	Value					
Reference channel				R.39-1 FDD	R.39 FDD		
Channel bandwidth	MHz	1.4	3	5	10	15	20
Allocated resource blocks				25	50		
Allocated subframes per Radio Frame(Note1)				6	6		
Modulation				64QAM	64QAM		
Target Coding Rate				2/3	2/3		
Information Bit Payload (Note 2)							
For Sub-Frames 1,2,3,6,7,8	Bits			9912	19848		
For Sub-Frames 0,4,5,9	Bits			N/A	N/A		
Number of Code Blocks per Sub-Frame (Note 3)				2	4		
Binary Channel Bits Per Subframe							
For Sub-Frames 1,2,3,6,7,8	Bits			15300	30600		
For Sub-Frames 0,4,5,9	Bits			N/A	N/A		
MBMS UE Category				$\geq 1$	$\geq 2$		
Note 1:	For FDD mode, up to 6 subframes (#1/2/3/6/7/8) are available for MBMS, in line with TS 36.331.						
Note 2:	2 OFDM symbols are reserved for PDCCH; and reference signal allocated as per TS 36.211.						
Note 3:	If more than one Code Block is present, an additional CRC sequence of L = 24 Bits is attached to each Code Block (otherwise L = 0 Bit).						

**Table A.3.8.1-4: Fixed Reference Channel for subcarrier spacing 1.25kHz with FeMBMS MBMS/Unicast-mixed cell**

Parameter	PMCH					
	Unit	Value				
Reference channel			R.81-1 FDD	R.81-2 FDD		
Channel bandwidth	MHz		10	10		
Allocated resource blocks			50	50		
Allocated subframes per Radio Frame(Note1)			8	8		
Modulation			16QAM	64QAM		
Target Coding Rate			1/2	2/3		
Information Bit Payload (Note 2)						
For Sub-Frames 1,2,3,4,6,7,8,9	Bits		11448	25456		
For Sub-Frames 0,5			N/A	N/A		
Number of Code Blocks per Sub-Frame (Note 3)			3	5		
Binary Channel Bits Per Subframe						
For Sub-Frames 1,2,3,4,6,7,8,9	Bits		24000	36000		
For Sub-Frames 0,5			N/A	N/A		
MBMS UE Category			$\geq 2$	$\geq 2$		

Note 1: For FDD mode, up to 8 subframes (#1/2/3/4/6/7/8/9) are available for MBMS, in line with TS 36.331 [7].  
Note 2: Zero OFDM symbols are reserved for PDCCH; and no CRS allocated as per TS 36.211 [4].  
Note 3: If more than one Code Block is present, an additional CRC sequence of L = 24 Bits is attached to each Code Block (otherwise L = 0 Bit).

**Table A.3.8.1-5: Fixed Reference Channel for subcarrier spacing 7.5kHz with FeMBMS MBMS/Unicast-mixed cell**

Parameter	PMCH					
	Unit	Value				
Reference channel				R.82-1 FDD		
Channel bandwidth	MHz			10		
Allocated resource blocks				50		
Allocated subframes per Radio Frame(Note1)				8		
Modulation				16QAM		
Target Coding Rate				1/2		
Information Bit Payload (Note 2)						
For Sub-Frames 1,2,3,4,6,7,8,9	Bits			12960		
For Sub-Frames 0,5	Bits			N/A		
Number of Code Blocks per Sub-Frame (Note 3)				3		
Binary Channel Bits Per Subframe						
For Sub-Frames 1,2,3,4,6,7,8,9	Bits			25200		
For Sub-Frames 0,5	Bits			N/A		
MBMS UE Category				$\geq 2$		

Note 1: For FDD mode, up to 8 subframes (#1/2/3/4/6/7/8/9) are available for MBMS, in line with TS 36.331 [7].  
Note 2: Zero OFDM symbols are reserved for PDCCH; and no CRS allocated as per TS 36.211 [4].  
Note 3: If more than one Code Block is present, an additional CRC sequence of L = 24 Bits is attached to each Code Block (otherwise L = 0 Bit).

**Table A.3.8.1-6: Fixed Reference Channel for subcarrier spacing 1.25kHz with MBMS dedicated cell**

Parameter	PMCH					
	Unit	Value				
Reference channel			R.83-1 FDD	R.83-2 FDD		
Channel bandwidth	MHz		10	10		
Allocated resource blocks			50	50		
Allocated subframes per Radio Frame(Note1)			10	10		
Modulation			16QAM	64QAM		
Target Coding Rate			1/2	2/3		
Information Bit Payload (Note 2)						
For Sub-Frames 0,1,2,3,4,5,6,7,8,9	Bits		11448	25456		
Number of Code Blocks per Sub-Frame (Note 3)			3	5		
Binary Channel Bits Per Subframe						
For Sub-Frames 0,1,2,3,4,5,6,7,8,9	Bits		24000	36000		
MBMS UE Category			≥ 2	≥ 2		
Note 1: For FDD mode, all 10 subframes are available for MBMS, in line with TS 36.331 [7]. Note 2: Zero OFDM symbols are reserved for PDCCH; and no CRS allocated as per TS 36.211 [4]. Note 3: If more than one Code Block is present, an additional CRC sequence of L = 24 Bits is attached to each Code Block (otherwise L = 0 Bit).						

**Table A.3.8.1-7: Fixed Reference Channel for subcarrier spacing 7.5kHz with with MBMS dedicated cell**

Parameter	PMCH					
	Unit	Value				
Reference channel			R.84-1 FDD			
Channel bandwidth	MHz		10			
Allocated resource blocks			50			
Allocated subframes per Radio Frame(Note1)			10			
Modulation			16QAM			
Target Coding Rate			1/2			
Information Bit Payload (Note 2)						
For Sub-Frames 0,1,2,3,4,5,6,7,8,9	Bits		12960			
Number of Code Blocks per Sub-Frame (Note 3)			3			
Binary Channel Bits Per Subframe						
For Sub-Frames 0,1,2,3,4,5,6,7,8,9	Bits		25200			
MBMS UE Category			≥ 2			
Note 1: For FDD mode, all 10 subframes are available for MBMS, in line with TS 36.331 [7]. Note 2: Zero OFDM symbols are reserved for PDCCH; and no CRS allocated as per TS 36.211 [4]. Note 3: If more than one Code Block is present, an additional CRC sequence of L = 24 Bits is attached to each Code Block (otherwise L = 0 Bit).						



**Table A.3.8.1-8: Fixed Reference Channel for subcarrier spacing 15kHz with with MBMS dedicated cell**

Parameter	PMCH					
	Unit	Value				
Reference channel			R.85-1 FDD	R.85-2 FDD	R.85-3 FDD	
Channel bandwidth	MHz		3	5	10	
Allocated resource blocks			15	25	50	
Allocated subframes per Radio Frame(Note1)			10	10	10	
Modulation			QPSK	16QAM	64QAM	
Target Coding Rate			1/3	1/2	2/3	
Information Bit Payload (Note 2)						
For Sub-Frames 0,1,2,3,4,5,6,7,8,9	Bits		1064	4968	19848	
Number of Code Blocks per Sub-Frame (Note 3)			1	1	4	
Binary Channel Bits Per Subframe						
For Sub-Frames 0,1,2,3,4,5,6,7,8,9	Bits		3060	10200	30600	
MBMS UE Category			≥ 1	≥ 1	≥ 2	
Note 1: For FDD mode, all 10 subframes are available for MBMS, in line with TS 36.331 [7]. Note 2: 2 OFDM symbols are reserved for PDCCH; and no CRS allocated as per TS 36.211 [4]. Note 3: If more than one Code Block is present, an additional CRC sequence of L = 24 Bits is attached to each Code Block (otherwise L = 0 Bit).						

**Table A.3.8.1-9: Fixed Reference Channel for subcarrier spacing 0.37 kHz with 5G terrestrial broadcast MBMS dedicated cell**

Parameter	PMCH					
	Unit	Value				
Reference channel			R.106-1 FDD	R.106-2 FDD		
Channel bandwidth	MHz		10	10		
Allocated resource blocks			50	50		
Allocated slots per 40ms(Note1)			13	13		
Modulation			64QAM	64QAM		
Target Coding Rate			0.48	0.52		
Information Bit Payload (Note 2)						
For each slot	Bits		63776	63776		
Number of Code Blocks per Sub-Frame (Note 3)			11	11		
Binary Channel Bits Per Subframe						
For each slot	Bits		133650	121500		
MBMS UE Category			≥ 2	≥ 2		
Note 1: First subframe of every 40ms is allocated for non-MBMS transmission. Note 2: Zero OFDM symbols are reserved for PDCCH; and no CRS allocated as per TS 36.211 [4]. Note 3: If more than one Code Block is present, an additional CRC sequence of L = 24 Bits is attached to each Code Block (otherwise L = 0 Bit).						

**Table A.3.8.1-10: Fixed Reference Channel for subcarrier spacing 2.5 kHz with 5G terrestrial broadcast MBMS dedicated cell**

Parameter	PMCH					
	Unit	Value				

Reference channel			R.107 FDD				
Channel bandwidth	MHz		10				
Allocated resource blocks			50				
Allocated subframes per 40ms(Note1)			39				
Modulation			16QAM				
Target Coding Rate			0.46				
Information Bit Payload (Note 2)							
For each subframes	Bits		9912				
Number of Code Blocks per Sub-Frame (Note 3)			2				
Binary Channel Bits Per Subframe							
For each subframes	Bits		21600				
MBMS UE Category			≥ 2				
<p>Note 1: First subframe of every 40ms is allocated for non-MBMS transmission.</p> <p>Note 2: Zero OFDM symbols are reserved for PDCCH; and no CRS allocated as per TS 36.211 [4].</p> <p>Note 3: If more than one Code Block is present, an additional CRC sequence of L = 24 Bits is attached to each Code Block (otherwise L = 0 Bit).</p>							

### A.3.8.2 TDD

**Table A.3.8.2-1: Fixed Reference Channel QPSK R=1/3**

Parameter	PMCH						
	Unit	Value					
Reference channel		R.40 TDD			R.37 TDD		
Channel bandwidth	MHz	1.4	3	5	10	15	20
Allocated resource blocks		6			50		
Uplink-Downlink Configuration(Note 1)		5			5		
Allocated subframes per Radio Frame		5			5		
Modulation		QPSK			QPSK		
Target Coding Rate		1/3			1/3		
Information Bit Payload (Note 2)							
For Sub-Frames 3,4,7,8,9	Bits	408			3624		
For Sub-Frames 0,1,2,5,6	Bits	N/A			N/A		
Number of Code Blocks per Subframe (Note 3)		1			1		
Binary Channel Bits Per Subframe							
For Sub-Frames 3,4,7,8,9	Bits	1224			10200		
For Sub-Frames 0,1,2,5,6	Bits	N/A			N/A		
MBMS UE Category		≥ 1			≥ 1		
<p>Note 1: For TDD mode, in line with TS 36.331, Uplink-Downlink Configuration 5 is proposed, up to 5 subframes (#3/4/7/8/9) are available for MBMS.</p> <p>Note 2: 2 OFDM symbols are reserved for PDCCH; reference signal allocated as per TS 36.211.</p> <p>Note 3: If more than one Code Block is present, an additional CRC sequence of L = 24 Bits is attached to each Code Block (otherwise L = 0 Bit).</p>							

Table A.3.8.2-2: Fixed Reference Channel 16QAM R=1/2

Parameter	PMCH						
	Unit	Value					
Reference channel					R.38 TDD		
Channel bandwidth	MHz	1.4	3	5	10	15	20
Allocated resource blocks					50		
Uplink-Downlink Configuration(Note 1)					5		
Allocated subframes per Radio Frame					5		
Modulation					16QAM		
Target Coding Rate					1/2		
Information Bit Payload (Note 2)							
For Sub-Frames 3,4,7,8,9	Bits				9912		
For Sub-Frames 0,1,2,5,6	Bits				N/A		
Number of Code Blocks per Subframe (Note 3)					2		
Binary Channel Bits Per Subframe							
For Sub-Frames 3,4,7,8,9	Bits				20400		
For Sub-Frames 0,1,2,5,6	Bits				N/A		
MBMS UE Category					$\geq 1$		
Note 1:	For TDD mode, in line with TS 36.331, Uplink-Downlink Configuration 5 is proposed, up to 5 subframes (#3/4/7/8/9) are available for MBMS.						
Note 2:	2 OFDM symbols are reserved for PDCCH; reference signal allocated as per TS 36.211.						
Note 3:	If more than one Code Block is present, an additional CRC sequence of L = 24 Bits is attached to each Code Block (otherwise L = 0 Bit).						

Table A.3.8.2-3: Fixed Reference Channel 64QAM R=2/3

Parameter	PMCH						
	Unit	Value					
Reference channel				R.39-1TDD	R.39 TDD		
Channel bandwidth	MHz	1.4	3	5	10	15	20
Allocated resource blocks				25	50		
Uplink-Downlink Configuration(Note 1)				5	5		
Allocated subframes per Radio Frame				5	5		
Modulation				64QAM	64QAM		
Target Coding Rate				2/3	2/3		
Information Bit Payload (Note 2)							
For Sub-Frames 3,4,7,8,9	Bits			9912	19848		
For Sub-Frames 0,1,2,5,6	Bits			N/A	N/A		
Number of Code Blocks per Sub-Frame (Note 3)				2	4		
Binary Channel Bits Per Subframe							
For Sub-Frames 3,4,7,8,9	Bits			15300	30600		
For Sub-Frames 0,1,2,5,6	Bits			N/A	N/A		
MBMS UE Category				$\geq 1$	$\geq 2$		
Note 1:	For TDD mode, in line with TS 36.331, Uplink-Downlink Configuration 5 is proposed, up to 5 subframes (#3/4/7/8/9) are available for MBMS.						
Note 2:	2 OFDM symbols are reserved for PDCCH; reference signal allocated as per TS 36.211.						
Note 3:	If more than one Code Block is present, an additional CRC sequence of L = 24 Bits is attached to each Code Block (otherwise L = 0 Bit).						

## A.3.9 Reference measurement channels for sustained downlink data rate provided by lower layers

### A.3.9.1 FDD

**Table A.3.9.1-1: Fixed Reference Channel for sustained data-rate test (FDD 64QAM)**

Parameter	Unit	Value							
		R.31-1 FDD	R.31-2 FDD	R.31-3 FDD	R.31-3A FDD	R.31-3C FDD	R.31-4 FDD	R.31-4B FDD	R.31-5 FDD
Reference channel									
Channel bandwidth	MHz	10	10	20	10	15	20	15	15
Allocated resource blocks (Note 8)		Note 5	Note 6	Note 7	Note 6	Note 10	Note 7	Note 11	Note 9
Allocated subframes per Radio Frame		10	10	10	10	10	10	10	10
Modulation		64QAM	64QAM	64QAM	64QAM	64QAM	64QAM	64QAM	64QAM
Coding Rate									
For Sub-Frame 1,2,3,4,6,7,8,9		0.40	0.59	0.59	0.85	0.87	0.88	0.85	0.85
For Sub-Frame 5		0.40	0.64	0.62	0.89	0.88	0.87	0.87	0.91
For Sub-Frame 0		0.40	0.63	0.61	0.90	0.91	0.90	0.88	0.88
Information Bit Payload (Note 8)									
For Sub-Frames 1,2,3,4,6,7,8,9	Bits	10296	25456	51024	36696	51024	75376	55056	55056
For Sub-Frame 5	Bits	10296	25456	51024	35160	51024	71112	52752	52752
For Sub-Frame 0	Bits	10296	25456	51024	36696	51024	75376	55056	55056
Number of Code Blocks (Notes 3 and 8)									
For Sub-Frames 1,2,3,4,6,7,8,9	Bits	2	5	9	6	9	13	9	9
For Sub-Frame 5	Bits	2	5	9	6	9	12	9	9
For Sub-Frame 0	Bits	2	5	9	6	9	13	9	9
Binary Channel Bits (Note 8)									
For Sub-Frames 1,2,3,4,6,7,8,9	Bits	26100	43200	86400	43200	58752	86400	64800	64800
For Sub-Frame 5	Bits	26100	39744	82080	39744	57888	82080	60480	60480
For Sub-Frame 0	Bits	26100	40752	83952	40752	56304	83952	62352	62352
Number of layers		1	2	2	2	2	2	2	2
Max. Throughput averaged over 1 frame (Note 8)	Mbps	10.296	25.456	51.024	36.542	51.024	74.950	54.826	54.826
UE Categories		≥ 1	≥ 2	≥ 2	≥ 2	≥ 3	≥ 3	≥ 4	≥ 3
Note 1:	1 symbol allocated to PDCCH for all tests.								
Note 2:	Reference signal, synchronization signals and PBCH allocated as per TS 36.211 [4].								
Note 3:	If more than one Code Block is present, an additional CRC sequence of L = 24 Bits is attached to each Code Block (otherwise L = 0 Bit).								
Note 4:	Resource blocks $n_{PRB} = 0..2$ are allocated for SIB transmissions in sub-frame 5 for all bandwidths.								
Note 5:	Resource blocks $n_{PRB} = 6..14,30..49$ are allocated for the user data in all sub-frames.								
Note 6:	Resource blocks $n_{PRB} = 3..49$ are allocated for the user data in sub-frame 5, and resource blocks $n_{PRB} = 0..49$ in sub-frames 0,1,2,3,4,6,7,8,9.								
Note 7:	Resource blocks $n_{PRB} = 4..99$ are allocated for the user data in sub-frame 5, and resource blocks $n_{PRB} = 0..99$ in sub-frames 0,1,2,3,4,6,7,8,9.								
Note 8:	Given per component carrier per codeword.								
Note 9:	Resource blocks $n_{PRB} = 4..74$ are allocated for the user data in sub-frame 5, and resource blocks $n_{PRB} = 0..74$ in sub-frames 0,1,2,3,4,6,7,8,9.								
Note 10:	Resource blocks $n_{PRB} = 4..71$ are allocated for the user data in sub-frames 0,1,2,3,4,5,6,7,8,9.								
Note 11:	Resource blocks $n_{PRB} = 4..74$ are allocated for the user data in sub-frame 5, and resource blocks $n_{PRB} = 0..74$ in sub-frames 0,1,2,3,4,6,7,8,9.								

Table A.3.9.1-2: Fixed Reference Channel for sustained data-rate test (FDD 64QAM)

Parameter	Unit	Value						
		R.31-6 FDD	R.31-7 FDD	R.31-8 FDD	R.31-9 FDD	R.31-10 FDD	R.31-1A FDD	
Reference channel								
Channel bandwidth	MHz	5	10	15	20	5	20	
Allocated resource blocks (Note 5)		Note 4	Note 7	Note 8	Note 9	Note 4	Note 10	
Allocated subframes per Radio Frame		9	10	10	10	9	10	
Modulation		64QAM	64QAM	64QAM	64QAM	64QAM	64QAM	
Coding Rate								
For Sub-Frame 1,2,3,4,6,7,8,9,		0.85	0.78	0.77	0.79	0.78	0.41	
For Sub-Frame 5		N/A	0.80	0.79	0.81	N/A	0.41	
For Sub-Frame 0		0.83	0.83	0.8	0.81	0.85	0.41	
Information Bit Payload (Note 5)								
For Sub-Frames 1,2,3,4,6,7,8,9	Bits	18336	63776	93800	128496	31704	10296	
For Sub-Frame 5	Bits	N/A	59256	90816	124464	N/A	10296	
For Sub-Frame 0	Bits	15840	63776	93800	128496	30576	10296	
Number of Code Blocks (Notes 3 and 5)								
For Sub-Frames 1,2,3,4,6,7,8,9	Bits	3	11	16	21	6	2	
For Sub-Frame 5	Bits	N/A	10	15	21	N/A	2	
For Sub-Frame 0	Bits	3	11	16	21	5	2	
Binary Channel Bits (Note 5)								
For Sub-Frames 1,2,3,4,6,7,8,9	Bits	21600	81600	122400	163200	40800	25200	
For Sub-Frame 5	Bits	N/A	74976	114144	154944	N/A	25200	
For Sub-Frame 0	Bits	19152	76992	117792	158592	36192	25200	
Number of layers		2	4	4	4	4	1	
Max. Throughput averaged over 1 frame (Note 5)	Mbps	17.837	63.324	93.502	128.093	28.421	10.296	
UE Categories		≥ 2	≥ 6	≥ 6	≥ 6	≥ 6	≥ 1	
Note 1:	1 symbol allocated to PDCCH for all tests.							
Note 2:	Reference signal, synchronization signals and PBCH allocated as per TS 36.211 [4].							
Note 3:	If more than one Code Block is present, an additional CRC sequence of L = 24 Bits is attached to each Code Block (otherwise L = 0 Bit).							
Note 4:	Resource blocks $n_{PRB} = 0..24$ in sub-frames 0,1,2,3,4,6,7,8,9.							
Note 5:	Given per component carrier per codeword.							
Note 6:	$N_g=1/6$ .							
Note 7:	Resource blocks $n_{PRB} = 3..49$ are allocated for the user data in sub-frame 5, and resource blocks $n_{PRB} = 0..49$ in sub-frames 0,1,2,3,4,6,7,8,9.							
Note 8:	Resource blocks $n_{PRB} = 4..74$ are allocated for the user data in sub-frame 5, and resource blocks $n_{PRB} = 0..74$ in sub-frames 0,1,2,3,4,6,7,8,9.							
Note 9:	Resource blocks $n_{PRB} = 4..99$ are allocated for the user data in sub-frame 5, and resource blocks $n_{PRB} = 0..99$ in sub-frames 0,1,2,3,4,6,7,8,9.							
Note 10:	Resource blocks $n_{PRB} = 8..35$ are allocated for the user data in all sub-frames.							

Table A.3.9.1-3: Fixed Reference Channel for sustained data-rate test (FDD 256QAM)

Parameter	Unit	Value							
		R.68 FDD	R.68-1 FDD	R.68-2 FDD	R.68-3 FDD	R.68-4 FDD	R.68-5 FDD	R.68-6 FDD	R.68-7 FDD
Reference channel									
Channel bandwidth	MHz	20	15	10	5	10	15	20	5
Allocated resource blocks (Note 4)		Note 5	Note 6	Note 7	Note 8	Note 7	Note 6	Note 5	Note 8
Allocated subframes per Radio Frame		10	10	10	10	10	10	10	10
Modulation		256QA M	256QA M	256QA M	256QA M	256QA M	256QA M	256QA M	256QAM
Coding Rate									
For Sub-Frames 3,4,8,9		0.85	0.88	0.85	0.85	0.78	0.79	0.78	0.85
For Sub-Frames 1,2,6,7		0.74	0.74	0.74	0.77	0.78	0.79	0.78	0.77
For Sub-Frame 5		0.75	0.77	0.77	0.79	0.82	0.82	0.786	0.79
For Sub-Frame 0		0.76	0.77	0.78	0.84	0.83	0.82	0.80	0.84
Information Bit Payload (Note 4)									
For Sub-Frames 3,4,8,9	Bits	97896	75376	48936	24496	84760	128496	169544	42368
For Sub-Frames 1,2,6,7		84760	63776	42368	21384	84760	128496	169544	42368
For Sub-Frame 5	Bits	81176	61664	40576	19848	81176	124464	161760	39232
For Sub-Frame 0	Bits	84760	63776	42368	21384	84760	128496	169544	39232
Number of Code Blocks (Notes 3 and 4)									
For Sub-Frames 3,4,8,9	Bits	16	13	8	4	14	21	28	7
For Sub-Frames 1,2,6,7		14	11	7	4	14	21	28	7
For Sub-Frame 5	Bits	14	11	7	4	14	21	27	7
For Sub-Frame 0	Bits	14	11	7	4	14	21	28	7
Binary Channel Bits (Note 4)									
For Sub-Frames 3,4,8,9	Bits	115200	86400	57600	28800	108800	163200	217600	54400
For Sub-Frames 1,2,6,7		115200	86400	57600	28800	108800	163200	217600	54400
For Sub-Frame 5	Bits	109440	80640	52992	25344	99968	152192	206592	47744
For Sub-Frame 0	Bits	111936	83136	54336	25536	102656	157056	211456	48256
Number of layers		2	2	2	2	4	4	4	4
Max. Throughput averaged over 1 frame (Note 4)	Mbps	89.656	68.205	44.816	22.475	84.4016	128.093	168.766	41.741
UE Categories		11-12	11-12	11-12	11-12	11-12	11-12	11-12	11-12
UE DL Categories		≥ 11	≥ 11	≥ 11	≥ 11	13-14	13-14	13-14	13-14
Note 1:	1 symbol allocated to PDCCH for all tests.								
Note 2:	Reference signal, synchronization signals and PBCH allocated as per TS 36.211 [4].								
Note 3:	If more than one Code Block is present, an additional CRC sequence of L = 24 Bits is attached to each Code Block (otherwise L = 0 Bit).								
Note 4:	Given per component carrier per codeword.								
Note 5:	Resource blocks n <sub>PRB</sub> = 4..99 are allocated for the user data in sub-frame 5, and resource blocks n <sub>PRB</sub> = 0..99 in sub-frames 0,1,2,3,4,6,7,8,9.								
Note 6:	Resource blocks n <sub>PRB</sub> = 4..74 are allocated for the user data in sub-frame 5, and resource blocks n <sub>PRB</sub> = 0..74 in sub-frames 0,1,2,3,4,6,7,8,9.								
Note 7:	Resource blocks n <sub>PRB</sub> = 3..49 are allocated for the user data in sub-frame 5, and resource blocks n <sub>PRB</sub> = 0..49 in sub-frames 0,1,2,3,4,6,7,8,9.								
Note 8:	Resource blocks n <sub>PRB</sub> = 2..24 are allocated for the user data in sub-frame 5, and resource blocks n <sub>PRB</sub> = 0..24 in sub-frames 0,1,2,3,4,6,7,8,9.								

Table A.3.9.1-4: Fixed Reference Channel for sustained data-rate test (FDD 1024QAM)

Parameter	Unit	Value							
		R.105 FDD	R.105-1 FDD	R.105-2 FDD	R.105-3 FDD	R.105-4 FDD	R.105-5 FDD	R.105-6 FDD	R.105-7 FDD
Reference channel		20	15	10	5	20	15	10	5
Channel bandwidth	MHz	Note 5	Note 6	Note 7	Note 8	Note 7	Note 6	Note 5	Note 8
Allocated resource blocks (Note 4)		10	10	10	10	10	10	10	10
Allocated subframes per Radio Frame									
Modulation		1024QA M	1024QA M	1024QA M	1024QA M	1024QA M	1024QA M	1024QA M	1024QA M
Coding Rate									
For Sub-Frames 3,4,8,9		0.76	0.75	0.73	0.76	0.81	0.79	0.81	0.78
For Sub-Frames 1,2,6,7		0.76	0.75	0.73	0.76	0.81	0.79	0.81	0.78
For Sub-Frame 5		0.77	0.78	0.77	0.80	0.82	0.83	0.81	0.82
For Sub-Frame 0		0.79	0.78	0.78	0.86	0.83	0.82	0.86	0.87
Information Bit Payload (Note 4)									
For Sub-Frames 3,4,8,9	Bits	110136	81176	52752	27376	220296	161760	110136	52752
For Sub-Frames 1,2,6,7		110136	81176	52752	27376	220296	161760	110136	52752
For Sub-Frame 5	Bits	105528	78704	51024	25456	211936	157432	101840	48936
For Sub-Frame 0	Bits	110136	81176	52752	27376	220296	161760	110136	52752
Number of Code Blocks (Notes 3, and 4)									
For Sub-Frames 3,4,8,9	Bits	18	14	9	5	36	27	18	9
For Sub-Frames 1,2,6,7		18	14	9	5	36	27	18	9
For Sub-Frame 5	Bits	18	13	9	5	35	26	17	8
For Sub-Frame 0	Bits	18	14	9	5	36	27	18	9
Binary Channel Bits (Note 4)									
For Sub-Frames 3,4,8,9	Bits	144000	108000	72000	36000	272000	204000	136000	68000
For Sub-Frames 1,2,6,7		144000	108000	72000	36000	272000	204000	136000	68000
For Sub-Frame 5	Bits	136800	100800	66240	31680	258240	190240	124960	59680
For Sub-Frame 0	Bits	139920	103920	67920	31920	264320	196320	128320	60320
Number of layers		2	2	2	2	4	4	4	4
Max. Throughput averaged over 1 frame (Note 4)	Mbps	109.68	80.93	52.58	27.18	219.46	161.33	109.31	52.37
UE DL Categories		20, ≥22	20, ≥22	20, ≥22	20, ≥22	20, ≥22	20, ≥22	20, ≥22	20, ≥22
Note 1:	1 symbol allocated to PDCCH for all tests.								
Note 2:	Reference signal, synchronization signals and PBCH allocated as per TS 36.211 [4].								
Note 3:	If more than one Code Block is present, an additional CRC sequence of L = 24 Bits is attached to each Code Block (otherwise L = 0 Bit).								
Note 4:	Given per component carrier per codeword.								
Note 5:	Resource blocks $n_{PRB} = 4..99$ are allocated for the user data in sub-frame 5, and resource blocks $n_{PRB} = 0..99$ in sub-frames 0,1,2,3,4,6,7,8,9.								
Note 6:	Resource blocks $n_{PRB} = 4..74$ are allocated for the user data in sub-frame 5, and resource blocks $n_{PRB} = 0..74$ in sub-frames 0,1,2,3,4,6,7,8,9.								
Note 7:	Resource blocks $n_{PRB} = 3..49$ are allocated for the user data in sub-frame 5, and resource blocks $n_{PRB} = 0..49$ in sub-frames 0,1,2,3,4,6,7,8,9.								
Note 8:	Resource blocks $n_{PRB} = 2..24$ are allocated for the user data in sub-frame 5, and resource blocks $n_{PRB} = 0..24$ in sub-frames 0,1,2,3,4,6,7,8,9.								

## A.3.9.2 TDD

**Table A.3.9.2-1: Fixed Reference Channel for sustained data-rate test (TDD 64QAM)**



Parameter	Unit	Value								
		R.31-1 TDD	R.31-2 TDD	R.31-3 TDD	R.31-3A TDD	R.31-4 TDD	R.31-4A TDD	R.31-5 TDD	R.31-5A TDD	R.31-6 TDD
Reference channel										
Channel bandwidth	MHz	10	10	20	15	20	20	15	15	10
Allocated resource blocks		Note 6	Note 7	Note 8	Note 9	Note 8	Note 8	Note 11	Note 11	Note 7
Uplink-Downlink Configuration (Note 3)		5	5	5	1	1	2	1	2	1
Number of HARQ Processes per component carrier	Processes	15	15	15	7	7	10	7	10	7
Allocated subframes per Radio Frame (D+S)		8+1	8+1	8+1	4	4	6+2	4	6+2	4
Modulation		64QAM	64QAM	64QAM	64QAM	64QAM	64QAM	64QAM	64QAM	64QAM
Target Coding Rate										
For Sub-Frames 4,9		0.40	0.59	0.59	0.87	0.88	0.88	0.85	0.85	0.85
For Sub-Frames 3,8		0.40	0.59	0.59	N/A	N/A	0.88	N/A	0.85	N/A
For Sub-Frame 7		0.40	0.59	0.59	N/A	N/A	N/A	N/A	N/A	N/A
For Sub-Frames 0		0.40	0.62	0.61	0.90	0.90	0.90	0.88	0.88	0.90
For Sub-Frames 1		N/A	N/A	N/A	N/A	N/A	N/A	N/A	N/A	N/A
For Sub-Frames 5		0.40	0.64	0.62	0.88	0.87	0.87	0.87	0.87	0.88
For Sub-Frames 6		0.40	0.60	0.60	N/A	N/A	N/A	N/A	N/A	N/A
Information Bit Payload										
For Sub-Frames 4,9	Bits	10296	25456	51024	51024	75376	75376	55056	55056	36696
For Sub-Frames 3,8	Bits	10296	25456	51024	0	0	75376	0	55056	0
For Sub-Frame 7	Bits	10296	25456	51024	0	0	N/A	0	N/A	0
For Sub-Frame 0	Bits	10296	25456	51024	51024	75376	75376	55056	55056	36696
For Sub-Frame 1	Bits	0	0	0	0	0	0	0	0	0
For Sub-Frame 5	Bits	10296	25456	51024	51024	71112	71112	52752	52752	35160
For Sub-Frame 6	Bits	10296	25456	51024	0	0	0	0	0	0
Number of Code Blocks per Sub-Frame (Note 4)										
For Sub-Frames 4,9		2	5	9	9	13	13	9	9	6
For Sub-Frames 3,8		2	5	9	N/A	N/A	13	N/A	9	N/A
For Sub-Frame 7		2	5	9	N/A	N/A	N/A	N/A	N/A	N/A
For Sub-Frame 0		2	5	9	9	13	13	9	9	6
For Sub-Frame 1		N/A	N/A	N/A	N/A	N/A	N/A	N/A	N/A	N/A
For Sub-Frame 5		2	5	9	9	12	12	9	9	6
For Sub-Frame 6	Bits	2	5	9	n/a	N/A	N/A	N/A	N/A	N/A
Binary Channel Bits Per Sub-Frame										
For Sub-Frames 4,9	Bits	26100	43200	86400	58752	86400	86400	64800	64800	43200
For Sub-Frames 3,8	Bits	26100	43200	86400	0	0	86400	0	64800	0
For Sub-Frame 7	Bits	26100	43200	86400	0	0	86400	0	64800	0
For Sub-Frame 0	Bits	26100	41184	84384	56736	84384	84384	62784	62784	41184
For Sub-Frame 1	Bits	0	0	0	0	0	0	0	0	0
For Sub-Frame 5	Bits	26100	40176	82512	58320	82512	82512	60912	60912	40176
For Sub-Frame 6	Bits	26100	42768	85968	N/A	N/A	0	N/A	0	N/A
Number of layers		1	2	2	2	2	2	2	2	2
Max. Throughput averaged over 1 frame (Note 10)	Mbps	8.237	20.365	40.819	20.409	29.724	52.337	25.330	38.309	14.525
UE Category		≥ 1	≥ 2	≥ 2	≥ 2	≥ 3	≥ 3	≥ 3	≥ 3	≥ 2

- Note 1: 1 symbol allocated to PDCCH for all tests.
- Note 2: Reference signal, synchronization signals and PBCH allocated as per TS 36.211 [4].
- Note 3: As per Table 4.2-2 in TS 36.211 [4].
- Note 4: If more than one Code Block is present, an additional CRC sequence of  $L = 24$  Bits is attached to each Code Block (otherwise  $L = 0$  Bit).
- Note 5: Resource blocks  $n_{PRB} = 0..2$  are allocated for SIB transmissions in sub-frame 5 for all bandwidths.
- Note 6: Resource blocks  $n_{PRB} = 6..14,30..49$  are allocated for the user data in all subframes.
- Note 7: Resource blocks  $n_{PRB} = 3..49$  are allocated for the user data in sub-frame 5, and resource blocks  $n_{PRB} = 0..49$  in the available downlink sub-frames according to uplink downlink configurations used .
- Note 8: Resource blocks  $n_{PRB} = 4..99$  are allocated for the user data in sub-frame 5, and resource blocks  $n_{PRB} = 0..99$  in sub-frames 0,3,4,6,7,8,9.
- Note 9: Resource blocks  $n_{PRB} = 4..71$  are allocated for the user data in all sub-frames
- Note10: Given per component carrier per codeword.
- Note11: Resource blocks  $n_{PRB} = 4..74$  are allocated for the user data in sub-frame 5, and resource blocks  $n_{PRB} = 0..74$  in other downlink sub-frames.

**Table A.3.9.2-1A: Fixed Reference Channel for sustained data-rate test (TDD 64QAM)**

Parameter	Unit	Value							
		R.31-7 TDD	R.31-8 TDD	R.31-9 TDD	R.31-1A TDD	R.31-10 TDD	R.31-11 TDD	R.31-12 TDD	
Reference channel									
Channel bandwidth	MHz	10	15	20	20	10	15	20	
Allocated resource blocks		Note 7	Note 11	Note 12	Note 13	Note 14	Note 15	Note 16	
Uplink-Downlink Configuration (Note 3)		1	1	1	5	1	1	1	
Number of HARQ Processes per component carrier	Processes	7	7	7	15	7	7	7	
Allocated subframes per Radio Frame (D+S)		4	4	4	8+1	4	4	4	
Modulation		64QAM	64QAM	64QAM	64QAM	64QAM	64QAM	64QAM	
Target Coding Rate									
For Sub-Frames 4,9		0.78	0.77	0.79	0.41	0.85	0.84	0.85	
For Sub-Frames 3,8		N/A	N/A	N/A	0.41	N/A	N/A	N/A	
For Sub-Frame 7		N/A	N/A	N/A	0.41	N/A	N/A	N/A	
For Sub-Frames 0		0.82	0.79	0.81	0.41	0.75	0.76	0.74	
For Sub-Frames 1		N/A	N/A	N/A	N/A	N/A	N/A	N/A	
For Sub-Frames 5		0.79	0.79	0.80	0.41	0.75	0.76	0.75	
For Sub-Frames 6		N/A	N/A	N/A	0.41	N/A	N/A	N/A	
Information Bit Payload									
For Sub-Frames 4,9	Bits	63776	93800	128496	10296	110136	161760	220296	
For Sub-Frames 3,8	Bits	0	0	0	10296	N/A	N/A	N/A	
For Sub-Frame 7	Bits	0	0	0	10296	N/A	N/A	N/A	
For Sub-Frame 0	Bits	63776	93800	128496	10296	87936	137792	187712	
For Sub-Frame 1	Bits	0	0	0	0	0	0	0	
For Sub-Frame 5	Bits	59256	90816	124464	10296	81176	128496	181656	
For Sub-Frame 6	Bits	0	0	0	10296	0	0	0	
Number of Code Blocks per Sub-Frame (Note 4)									
For Sub-Frames 4,9		11	16	21	2	18	27	36	
For Sub-Frames 3,8		N/A	N/A	N/A	2	N/A	N/A	N/A	
For Sub-Frame 7		N/A	N/A	N/A	2	N/A	N/A	N/A	
For Sub-Frame 0		11	16	21	2	15	23	31	
For Sub-Frame 1		N/A	N/A	N/A	N/A	N/A	N/A	N/A	
For Sub-Frame 5		10	15	21	2	14	21	30	
For Sub-Frame 6	Bits	N/A	N/A	N/A	2	N/A	N/A	N/A	
Binary Channel Bits Per Sub-Frame									
For Sub-Frames 4,9	Bits	81600	122400	163200	25200	129600	194400	259200	
For Sub-Frames 3,8	Bits	0	0	0	25200	0	0	0	
For Sub-Frame 7	Bits	0	0	0	25200	0	0	0	
For Sub-Frame 0	Bits	77856	118656	159456	25200	118080	181440	253440	
For Sub-Frame 1	Bits	0	0	0	0	0	0	0	
For Sub-Frame 5	Bits	75840	115008	155808	25200	109440	169920	241920	
For Sub-Frame 6	Bits	0	0	0	25200	0	0	0	
Number of layers		4	4	4	1	8	8	8	
Max. Throughput averaged over 1 frame (Note 10)	Mbps	25.058	37.222	50.996	8.237	77.877	117.962	161.992	
UE Category		≥ 6	≥ 6	≥ 6	≥ 1	8	8	8	
UE DL Category						14, 17,18,1 9,20,22 ,23,24, 25,26	14, 17,18,1 9,20,22 ,23,24, 25,26	14, 17,18,1 9,20,22 ,23,24, 25,26	

Note 1:	1 symbol allocated to PDCCH for all tests.
Note 2:	Reference signal, synchronization signals and PBCH allocated as per TS 36.211 [4].
Note 3:	As per Table 4.2-2 in TS 36.211 [4].
Note 4:	If more than one Code Block is present, an additional CRC sequence of $L = 24$ Bits is attached to each Code Block (otherwise $L = 0$ Bit).
Note 5:	The first RBG, i.e. resource blocks $n_{PRB} = 0..2$ for 10MHz channel bandwidth, $n_{PRB} = 0..3$ for 15MHz and 20MHz channel bandwidths are allocated for SIB transmissions in sub-frame 5.
Note 6:	Void
Note 7:	Resource blocks $n_{PRB} = 3..49$ are allocated for the user data in sub-frame 5, and resource blocks $n_{PRB} = 0..49$ in other available downlink sub-frames according to uplink downlink configurations used .
Note 8:	Void
Note 9:	Void
Note 10:	Given per component carrier per codeword.
Note 11:	Resource blocks $n_{PRB} = 4..74$ are allocated for the user data in sub-frame 5, and resource blocks $n_{PRB} = 0..74$ in other downlink sub-frames.
Note 12:	Resource blocks $n_{PRB} = 4..99$ are allocated for the user data in sub-frame 5, and resource blocks $n_{PRB} = 0..99$ in other downlink sub-frames.
Note 13:	Resource blocks $n_{PRB} = 8..35$ are allocated for the user data in all sub-frames.
Note 14:	84 resource blocks $n_{PRB} = 4..43$ and $n_{PRB} = 56..99$ are allocated for the user data in sub-frame 5, and 88 resource blocks $n_{PRB} = 0..43$ and $n_{PRB} = 56..99$ are allocated for the user data in sub-frame 0, and 100 resource blocks $n_{PRB} = 0..99$ in other downlink sub-frames.
Note 15:	59 resource blocks $n_{PRB} = 4..31$ and $n_{PRB} = 44..74$ are allocated for the user data in sub-frame 5, and 63 resource blocks $n_{PRB} = 0..31$ and $n_{PRB} = 44..74$ are allocated for the user data in sub-frame 0, and 75 resource blocks $n_{PRB} = 0..74$ in other downlink sub-frames.
Note 16:	38 resource blocks $n_{PRB} = 3..20$ and $n_{PRB} = 30..49$ are allocated for the user data in sub-frame 5, and 41 resource blocks $n_{PRB} = 0..20$ and $n_{PRB} = 30..49$ are allocated for the user data in sub-frame 0, and 50 resource blocks $n_{PRB} = 0..49$ in other available downlink sub-frames according to uplink downlink configurations used.

**Table A.3.9.2-2: Fixed Reference Channel for sustained data-rate test (TDD 256QAM)**

Parameter	Unit	Value				
		R.68 TDD	R.68-1 TDD	R.68-2 TDD	R.68-3 TDD	R.68-4 TDD
Reference channel						
Channel bandwidth	MHz	20	15	10	20	15
Allocated resource blocks	PRB	Note 6	Note 7	Note 8	Note 6	Note 7
Uplink-Downlink Configuration (Note 3)		1	1	1	[2]	[2]
Number of HARQ Processes per component carrier	Processes	7	7	7	[10]	[10]
Allocated subframes per Radio Frame (D+S)		4+2	4+2	4+2	[6+2]	[6+2]
Modulation		256QAM	256QAM	256QAM	256QAM	256QAM
Target Coding Rate						
For Sub-Frame 0		0.76	0.77	0.78	0.76	0.77
For Sub-Frame 1		N/A	N/A	N/A	N/A	N/A
For Sub-Frames 3		N/A	N/A	N/A	0.74	0.79
For Sub-Frames 4		0.74	0.79	0.74	0.74	0.79
For Sub-Frame 5		0.74	0.76	0.76	0.74	0.76
For Sub-Frame 6		N/A	N/A	N/A	[N/A]	[N/A]
For Sub-Frame 7		N/A	N/A	N/A	[N/A]	[N/A]
For Sub-Frames 8		N/A	N/A	N/A	0.85	0.88
For Sub-Frames 9		0.85	0.88	0.85	0.85	0.88
Information Bit Payload						
For Sub-Frame 0	Bits	84760	63776	42368	84760	63776
For Sub-Frame 1	Bits	0	0	0	0	0
For Sub-Frames 3	Bits	N/A	N/A	N/A	84760	63776
For Sub-Frames 4	Bits	84760	63776	42368	84760	63776
For Sub-Frame 5	Bits	81176	61664	40576	81176	61664
For Sub-Frame 6	Bits	0	0	0	[0]	[0]
For Sub-Frame 7		N/A	N/A	N/A	[N/A]	[N/A]
For Sub-Frames 8	Bits	N/A	N/A	N/A	97896	75376
For Sub-Frames 9	Bits	97896	75376	48936	97896	75376
Number of Code Blocks per Sub-Frame (Note 4)						
For Sub-Frame 0		14	11	7	14	11
For Sub-Frame 1		N/A	N/A	N/A	N/A	N/A
For Sub-Frames 3		N/A	N/A	N/A	14	11
For Sub-Frames 4		14	11	7	14	11
For Sub-Frame 5		14	11	7	14	11
For Sub-Frame 6		N/A	N/A	N/A	[N/A]	[11]
For Sub-Frame 7		N/A	N/A	N/A	[N/A]	[11]
For Sub-Frames 8		N/A	N/A	N/A	16	13
For Sub-Frames 9		16	13	8	16	13
Binary Channel Bits Per Sub-Frame						
For Sub-Frame 0	Bits	112512	83712	54912	112512	83712
For Sub-Frame 1	Bits	0	0	0	0	0
For Sub-Frames 3	Bits	N/A	N/A	N/A	115200	86400
For Sub-Frames 4	Bits	115200	86400	57600	115200	86400
For Sub-Frame 5		110016	81216	53568	110016	81216
For Sub-Frame 6	Bits	0	0	0	[0]	[0]
For Sub-Frame 7		N/A	N/A	N/A	[N/A]	[N/A]
For Sub-Frames 8	Bits	N/A	N/A	N/A	115200	86400
For Sub-Frames 9	Bits	115200	86400	57600	115200	86400
Number of layers		2	2	2	2	2
Max. Throughput averaged over 1 frame (Note 5)	Mbps	34.859	26.459	17.425	[53.125]	[40.374]
UE Categories		11-12	11-12	11-12	11-12	11-12
UE DL Categories		≥ 11	≥ 11	≥ 11	≥ 11	≥ 11

- Note 1: 1 symbol allocated to PDCCH for all tests.
- Note 2: Reference signal, synchronization signals and PBCH allocated as per TS 36.211 [4].
- Note 3: As per Table 4.2-2 in TS 36.211 [4].
- Note 4: If more than one Code Block is present, an additional CRC sequence of  $L = 24$  Bits is attached to each Code Block (otherwise  $L = 0$  Bit).
- Note 5: Given per component carrier per codeword.
- Note 6: Resource blocks  $n_{PRB} = 4..99$  are allocated for the user data in sub-frame 5, and resource blocks  $n_{PRB} = 0..99$  in other downlink sub-frames.
- Note 7: Resource blocks  $n_{PRB} = 4..74$  are allocated for the user data in sub-frame 5, and resource blocks  $n_{PRB} = 0..74$  in other downlink sub-frames.
- Note 8: Resource blocks  $n_{PRB} = 3..49$  are allocated for the user data in sub-frame 5, and resource blocks  $n_{PRB} = 0..49$  in the available downlink sub-frames according to uplink downlink configurations used.



**Table A.3.9.2-3: Fixed Reference Channel for sustained data-rate test (TDD 256QAM)**

Parameter	Unit	Value					
		R.68-5 TDD	R.68-6 TDD	R.68-7 TDD	R.68-8 TDD	R.68-9 TDD	R.68-10 TDD
Reference channel							
Channel bandwidth	MHz	10	15	20	10	15	20
Allocated resource blocks	PRB	Note 8	Note 7	Note 6	Note 10	Note 11	Note 12
Uplink-Downlink Configuration (Note 3)		1	1	1	1	1	1
Number of HARQ Processes per component carrier	Processes	7	7	7	7	7	7
Allocated subframes per Radio Frame (D+S)		4+2	4+2	4+2	4	4	4
Modulation		256QAM	256QAM	256QAM	256QAM	256QAM	256QAM
Target Coding Rate							
For Sub-Frame 0		0.82	0.82	0.80	0.70	0.70	0.70
For Sub-Frame 1		N/A	N/A	N/A	N/A	N/A	N/A
For Sub-Frames 3		N/A	N/A	N/A	N/A	N/A	N/A
For Sub-Frames 4		0.78	0.79	0.78	0.77	0.76	0.77
For Sub-Frame 5		0.81	0.82	0.78	0.70	0.70	0.69
For Sub-Frame 6		N/A	N/A	N/A	N/A	N/A	N/A
For Sub-Frame 7		N/A	N/A	N/A	N/A	N/A	N/A
For Sub-Frames 8		N/A	N/A	N/A	N/A	N/A	N/A
For Sub-Frames 9		0.78	0.79	0.78	0.77	0.76	0.77
Information Bit Payload							
For Sub-Frame 0	Bits	84760	128496	169544	110136	169544	236160
For Sub-Frame 1	Bits	0	0	0	0	0	0
For Sub-Frames 3	Bits	N/A	N/A	N/A	N/A	N/A	N/A
For Sub-Frames 4	Bits	84760	128496	169544	133208	195816	266440
For Sub-Frame 5	Bits	81176	124464	161760	101840	157432	220296
For Sub-Frame 6	Bits	0	0	0	0	0	0
For Sub-Frame 7		N/A	N/A	N/A	N/A	N/A	N/A
For Sub-Frames 8	Bits	N/A	N/A	N/A	N/A	N/A	N/A
For Sub-Frames 9	Bits	84760	128496	169544	133208	195816	266440
Number of Code Blocks per Sub-Frame (Note 4)							
For Sub-Frame 0		14	21	28	18	28	39
For Sub-Frame 1		0	0	0	0	0	0
For Sub-Frames 3		N/A	N/A	N/A	N/A	N/A	N/A
For Sub-Frames 4		14	21	28	22	32	44
For Sub-Frame 5		14	21	27	17	26	36
For Sub-Frame 6		0	0	0	0	0	0
For Sub-Frame 7		N/A	N/A	N/A	N/A	N/A	N/A
For Sub-Frames 8		N/A	N/A	N/A	N/A	N/A	N/A
For Sub-Frames 9		14	21	28	22	32	44
Binary Channel Bits Per Sub-Frame							
For Sub-Frame 0	Bits	103808	158208	212608	157440	241920	337920
For Sub-Frame 1	Bits	0	0	0	0	0	0
For Sub-Frames 3	Bits	N/A	N/A	N/A	N/A	N/A	N/A
For Sub-Frames 4	Bits	108800	163200	217600	172800	259200	345600
For Sub-Frame 5		101120	153344	207744	145920	226560	322560
For Sub-Frame 6	Bits	0	0	0	0	0	0
For Sub-Frame 7		N/A	N/A	N/A	N/A	N/A	N/A
For Sub-Frames 8	Bits	N/A	N/A	N/A	N/A	N/A	N/A
For Sub-Frames 9	Bits	108800	163200	217600	172800	259200	345600
Number of layers		4	4	4	8	8	8
Max. Throughput averaged over 1 frame (Note 5)	Mbps	33.546	50.995	67.039	95.678	143.722	197.867
UE Categories		11-12	11-12	11-12	8	8	8
UE DL Categories		13-14	13-14	13-14	14, 17,18,19, 20,22,23, 24,25,26	14, 17,18,19, 20,22,23, 24,25,26	14, 17,18,19, 20,22,23, 24,25,26

- Note 1: 1 symbol allocated to PDCCH for all tests.
- Note 2: Reference signal, synchronization signals and PBCH allocated as per TS 36.211 [4].
- Note 3: As per Table 4.2-2 in TS 36.211 [4].
- Note 4: If more than one Code Block is present, an additional CRC sequence of  $L = 24$  Bits is attached to each Code Block (otherwise  $L = 0$  Bit).
- Note 5: Given per component carrier per codeword.
- Note 6: Resource blocks  $n_{PRB} = 4..99$  are allocated for the user data in sub-frame 5, and resource blocks  $n_{PRB} = 0..99$  in other downlink sub-frames.
- Note 7: Resource blocks  $n_{PRB} = 4..74$  are allocated for the user data in sub-frame 5, and resource blocks  $n_{PRB} = 0..74$  in other downlink sub-frames.
- Note 8: Resource blocks  $n_{PRB} = 3..49$  are allocated for the user data in sub-frame 5, and resource blocks  $n_{PRB} = 0..49$  in the available downlink sub-frames according to uplink downlink configurations used.
- Note 9: The first RBG, i.e. resource blocks  $n_{PRB} = 0..2$  for 10MHz channel bandwidth,  $n_{PRB} = 0..3$  for 15MHz and 20MHz channel bandwidths are allocated for SIB transmissions in sub-frame 5.
- Note 10: 84 resource blocks  $n_{PRB} = 4..43$  and  $n_{PRB} = 56..99$  are allocated for the user data in sub-frame 5, and 88 resource blocks  $n_{PRB} = 0..43$  and  $n_{PRB} = 56..99$  are allocated for the user data in sub-frame 0, and 100 resource blocks  $n_{PRB} = 0..99$  in other downlink sub-frames.
- Note 11: 59 resource blocks  $n_{PRB} = 4..31$  and  $n_{PRB} = 44..74$  are allocated for the user data in sub-frame 5, and 63 resource blocks  $n_{PRB} = 0..31$  and  $n_{PRB} = 44..74$  are allocated for the user data in sub-frame 0, and 75 resource blocks  $n_{PRB} = 0..74$  in other downlink sub-frames.
- Note 12: 38 resource blocks  $n_{PRB} = 3..20$  and  $n_{PRB} = 30..49$  are allocated for the user data in sub-frame 5, and 41 resource blocks  $n_{PRB} = 0..20$  and  $n_{PRB} = 30..49$  are allocated for the user data in sub-frame 0, and 50 resource blocks  $n_{PRB} = 0..49$  in other available downlink sub-frames according to uplink downlink configurations used.

**Table A.3.9.2-4: Fixed Reference Channel for sustained data-rate test (TDD 1024QAM)**

Parameter	Unit	Value					
		R.105 TDD	R.105-1 TDD	R.105-2 TDD	R.105-3 TDD	R.105-4 TDD	R.105-5 TDD
Reference channel							
Channel bandwidth	MHz	20	15	10	20	15	10
Allocated resource blocks	PRB	Note 6	Note 7	Note 8	Note 6	Note 7	Note 8
Uplink-Downlink Configuration (Note 3)		1	1	1	1	1	1
Number of HARQ Processes per component carrier	Processes	7	7	7	7	7	7
Allocated subframes per Radio Frame (D+S)		4+2	4+2	4+2	4+2	4+2	4+2
Modulation		1024QAM	1024QAM	1024QAM	1024QAM	1024QAM	1024QAM
Target Coding Rate							
For Sub-Frame 0		0.78	0.78	0.80	0.83	0.82	0.85
For Sub-Frame 1		N/A	N/A	N/A	N/A	N/A	N/A
For Sub-Frames 3		N/A	N/A	N/A	N/A	N/A	N/A
For Sub-Frames 4		0.76	0.75	0.76	0.81	0.79	0.81
For Sub-Frame 5		0.77	0.78	0.76	0.82	0.82	0.81
For Sub-Frame 6		N/A	N/A	N/A	N/A	N/A	N/A
For Sub-Frame 7		N/A	N/A	N/A	N/A	N/A	N/A
For Sub-Frames 8		N/A	N/A	N/A	N/A	N/A	N/A
For Sub-Frames 9		0.76	0.75	0.76	0.81	0.79	0.81
Information Bit Payload							
For Sub-Frame 0	Bits	110136	81176	55056	220296	161760	110136
For Sub-Frame 1	Bits	0	0	0	0	0	0
For Sub-Frames 3	Bits	N/A	N/A	N/A	N/A	N/A	N/A
For Sub-Frames 4	Bits	110136	81176	55056	220296	161760	110136
For Sub-Frame 5	Bits	105528	78704	51024	211936	157432	101840
For Sub-Frame 6	Bits	0	0	0	0	0	0
For Sub-Frame 7		N/A	N/A	N/A	N/A	N/A	N/A
For Sub-Frames 8	Bits	N/A	N/A	N/A	N/A	N/A	N/A
For Sub-Frames 9	Bits	110136	81176	55056	220296	161760	110136
Number of Code Blocks per Sub-Frame (Note 4)							
For Sub-Frame 0		18	14	9	36	27	18
For Sub-Frame 1		N/A	N/A	N/A	0	0	0
For Sub-Frames 3		N/A	N/A	N/A	N/A	N/A	N/A
For Sub-Frames 4		18	14	9	36	27	18
For Sub-Frame 5		18	13	9	35	26	17
For Sub-Frame 6		N/A	N/A	N/A	0	0	0
For Sub-Frame 7		N/A	N/A	N/A	N/A	N/A	N/A
For Sub-Frames 8		N/A	N/A	N/A	N/A	N/A	N/A
For Sub-Frames 9		18	14	9	36	27	18
Binary Channel Bits Per Sub-Frame							
For Sub-Frame 0	Bits	140640	104640	68640	265760	197760	129760
For Sub-Frame 1	Bits	0	0	0	0	0	0
For Sub-Frames 3	Bits	N/A	N/A	N/A	N/A	N/A	N/A
For Sub-Frames 4	Bits	144000	108000	72000	272000	204000	136000
For Sub-Frame 5		137520	101520	66960	259680	191680	126400
For Sub-Frame 6	Bits	0	0	0	0	0	0
For Sub-Frame 7		N/A	N/A	N/A	N/A	N/A	N/A
For Sub-Frames 8	Bits	N/A	N/A	N/A	N/A	N/A	N/A
For Sub-Frames 9	Bits	144000	108000	72000	272000	204000	136000
Number of layers		2	2	2	4	4	4
Max. Throughput averaged over 1 frame (Note 5)	Mbps	43.5936	32.2232	20.928	87.2824	64.2712	43.2248
UE DL Categories		20, >22	20, >22	20, >22	20, >22	20, >22	20, >22

Note 1:	1 symbol allocated to PDCCH for all tests.
Note 2:	Reference signal, synchronization signals and PBCH allocated as per TS 36.211 [4].
Note 3:	As per Table 4.2-2 in TS 36.211 [4].
Note 4:	If more than one Code Block is present, an additional CRC sequence of L = 24 Bits is attached to each Code Block (otherwise L = 0 Bit).
Note 5:	Given per component carrier per codeword.
Note 6:	Resource blocks $n_{PRB} = 4..99$ are allocated for the user data in sub-frame 5, and resource blocks $n_{PRB} = 0..99$ in other downlink sub-frames.
Note 7:	Resource blocks $n_{PRB} = 4..74$ are allocated for the user data in sub-frame 5, and resource blocks $n_{PRB} = 0..74$ in other downlink sub-frames.
Note 8:	Resource blocks $n_{PRB} = 3..49$ are allocated for the user data in sub-frame 5, and resource blocks $n_{PRB} = 0..49$ in the available downlink sub-frames according to uplink downlink configurations used.

### A.3.9.3 FDD (EPDCCH scheduling)

**Table A.3.9.3-1: Fixed Reference Channel for sustained data-rate test with EPDCCH scheduling (FDD)**

Parameter	Unit	Value						
		R.31E-1 FDD	R.31E-2 FDD	R.31E-3 FDD	R.31E-3A FDD	R.31E-3C FDD	R.31E-4 FDD	R.31E-4B FDD
Reference channel								
Channel bandwidth	MHz	10	10	20	10	15	20	15
Allocated resource blocks (Note 8)		Note 5	Note 6	Note 7	Note 6	Note 9	Note 7	Note 10
Allocated subframes per Radio Frame		10	10	10	10	10	10	10
Modulation		64QAM	64QAM	64QAM	64QAM	64QAM	64QAM	64QAM
Coding Rate (subframes with PDCCH USS monitoring)								
For Sub-Frame 1,2,3,4,6,7,8,9,		0.3972	0.5926	0.5933	0.8533	0.8725	0.8763	0.8533
For Sub-Frame 5		0.3972	0.6441	0.6246	0.8889	0.8855	0.8702	0.8762
For Sub-Frame 0		0.3972	0.6282	0.6106	0.9046	0.9105	0.9018	0.8868
Coding Rate (subframes with EPDCCH USS monitoring)								
For Sub-Frame 1,2,3,4,6,7,8,9,		0.4114	0.6047	0.5993	0.8707	0.8855	0.8851	0.8649
For Sub-Frame 5		0.4114	0.6584	0.6312	0.9086	0.8990	0.8794	0.8889
For Sub-Frame 0		0.4114	0.6418	0.6170	0.9242	0.9246	0.9112	0.8993
Information Bit Payload (Note 8)								
For Sub-Frames 1,2,3,4,6,7,8,9	Bits	10296	25456	51024	36696	51024	75376	55056
For Sub-Frame 5	Bits	10296	25456	51024	35160	51024	71112	52752
For Sub-Frame 0	Bits	10296	25456	51024	36696	51024	75376	55056
Number of Code Blocks (Notes 3 and 8)								
For Sub-Frames 1,2,3,4,6,7,8,9	Bits	2	5	9	6	9	13	9
For Sub-Frame 5	Bits	2	5	9	6	9	12	9
For Sub-Frame 0	Bits	2	5	9	6	9	13	9
Binary Channel Bits (Note 8) (subframes with PDCCH USS monitoring)								
For Sub-Frames 1,2,3,4,6,7,8,9	Bits	26100	43200	86400	43200	58752	86400	64800
For Sub-Frame 5	Bits	26100	39744	82080	39744	57888	82080	60480
For Sub-Frame 0	Bits	26100	40752	83952	40752	56304	83952	62352
Binary Channel Bits (Note 8) (subframes with EPDCCH USS monitoring)								
For Sub-Frames 1,2,3,4,6,7,8,9	Bits	25200	42336	85536	42336	57888	85536	63936
For Sub-Frame 5	Bits	25200	38880	81216	38880	57024	81216	59616
For Sub-Frame 0	Bits	25200	39888	83088	39888	55440	83088	61488
Number of layers		1	2	2	2	2	2	2
Max. Throughput averaged over 1 frame (Note 8)	Mbps	10.296	25.456	51.024	36.542	51.024	74.950	54.826
UE Categories		≥ 1	≥ 2	≥ 2	≥ 2	≥ 3	≥ 3	≥ 4
Note 1:	1 symbol allocated to PDCCH for all tests.							

Note 2:	Reference signal, synchronization signals and PBCH allocated as per TS 36.211.
Note 3:	If more than one Code Block is present, an additional CRC sequence of L = 24 Bits is attached to each Code Block (otherwise L = 0 Bit).
Note 4:	Resource blocks $n_{PRB} = 0..2$ are allocated for SIB transmissions in sub-frame 5 for all bandwidths.
Note 5:	Resource blocks $n_{PRB} = 6..14,30..49$ are allocated for the user data in all sub-frames.
Note 6:	Resource blocks $n_{PRB} = 3..49$ are allocated for the user data in sub-frame 5, and resource blocks $n_{PRB} = 0..49$ in sub-frames 0,1,2,3,4,6,7,8,9.
Note 7:	Resource blocks $n_{PRB} = 4..99$ are allocated for the user data in sub-frame 5, and resource blocks $n_{PRB} = 0..99$ in sub-frames 0,1,2,3,4,6,7,8,9.
Note 8:	Given per component carrier per codeword.
Note 9:	Resource blocks $n_{PRB} = 4..71$ are allocated for the user data in sub-frames 0,1,2,3,4,5,6,7,8,9.
Note 10:	Resource blocks $n_{PRB} = 4..74$ are allocated for the user data in sub-frame 5, and resource blocks $n_{PRB} = 0..74$ in sub-frames 0,1,2,3,4,6,7,8,9.

### A.3.9.4 TDD (EPDCCH scheduling)

**Table A.3.9.4-1: Fixed Reference Channel for sustained data-rate with EPDCCH scheduling (TDD)**

Parameter	Unit	Value				
		R.31E-1 TDD	R.31E-2 TDD	R.31E-3 TDD	R.31E-3A TDD	R.31E-4 TDD
Reference channel						
Channel bandwidth	MHz	10	10	20	15	20
Allocated resource blocks		Note 6	Note 7	Note 8	Note 9	Note 8
Uplink-Downlink Configuration (Note 3)		5	5	5	1	1
Number of HARQ Processes per component carrier	Processes	15	15	15	7	7
Allocated subframes per Radio Frame (D+S)		8+1	8+1	8+1	4	4
Coding Rate (subframes with PDCCH USS monitoring)						
For Sub-Frames 4,9		0.3972	0.5926	0.5933	0.8725	0.8763
For Sub-Frames 3,7,8		0.3972	0.5926	0.5933	N/A	N/A
For Sub-Frames 1		N/A	N/A	N/A	N/A	N/A
For Sub-Frames 5		0.3972	0.6372	0.6213	0.8790	0.8656
For Sub-Frames 6		0.3972	0.5986	0.5963	N/A	N/A
For Sub-Frames 0		0.3972	0.6216	0.6075	0.9036	0.8972
Coding Rate (subframes with EPDCCH USS monitoring)						
For Sub-Frames 4,9		0.4114	0.6047	0.5993	0.8856	0.8851
For Sub-Frames 3,7,8		0.4114	0.6047	0.5993	N/A	N/A
For Sub-Frames 1		N/A	N/A	N/A	N/A	N/A
For Sub-Frames 5		0.4114	0.6512	0.6279	0.8922	0.8748
For Sub-Frames 6		0.4114	0.6109	0.6024	N/A	N/A
For Sub-Frames 0		0.4114	0.6349	0.6138	0.9175	0.9065
Information Bit Payload						
For Sub-Frames 4,9	Bits	10296	25456	51024	51024	75376
For Sub-Frames 3,7,8	Bits	10296	25456	51024	N/A	N/A
For Sub-Frame 1	Bits	0	0	0	N/A	N/A
For Sub-Frame 5	Bits	10296	25456	51024	51024	71112
For Sub-Frame 6	Bits	10296	25456	51024	N/A	N/A
For Sub-Frame 0	Bits	10296	25456	51024	51024	75376
Number of Code Blocks per Sub-Frame (Note 4)						
For Sub-Frames 4,9		2	5	9	9	13
For Sub-Frames 3,7,8		2	5	9	N/A	N/A
For Sub-Frame 1		N/A	N/A	N/A	N/A	N/A
For Sub-Frame 5		2	5	9	9	12
For Sub-Frame 6	Bits	2	5	9	N/A	N/A
For Sub-Frame 0		2	5	9	9	13

Binary Channel Bits per Sub-Frame (subframes with PDCCH USS monitoring)						
For Sub-Frames 4,9	Bits	26100	43200	86400	58752	86400
For Sub-Frames 3,7,8	Bits	26100	43200	86400	N/A	N/A
For Sub-Frame 1	Bits	0	0	0	N/A	N/A
For Sub-Frame 5	Bits	26100	40176	82512	58320	82512
For Sub-Frame 6	Bits	26100	42768	85968	N/A	N/A
For Sub-Frame 0	Bits	26100	41184	84384	56736	84384
Binary Channel Bits per Sub-Frame (subframes with EPDCCH USS monitoring)						
For Sub-Frames 4,9	Bits	25200	42336	85536	57888	85536
For Sub-Frames 3,7,8	Bits	25200	42336	85536	N/A	N/A
For Sub-Frame 1	Bits	0	0	0	N/A	N/A
For Sub-Frame 5	Bits	25200	39312	81648	57456	81648
For Sub-Frame 6	Bits	25200	41904	85104	N/A	N/A
For Sub-Frame 0	Bits	25200	40320	83520	55872	83520
Number of layers		1	2	2	2	2
Max. Throughput averaged over 1 frame (Note 10)	Mbps	8.237	20.365	40.819	20.409	29.724
UE Category		$\geq 1$	$\geq 2$	$\geq 2$	$\geq 2$	$\geq 3$
<p>Note 1: 1 symbol allocated to PDCCH for all tests.</p> <p>Note 2: Reference signal, synchronization signals and PBCH allocated as per TS 36.211 [4].</p> <p>Note 3: As per Table 4.2-2 in TS 36.211 [4].</p> <p>Note 4: If more than one Code Block is present, an additional CRC sequence of L = 24 Bits is attached to each Code Block (otherwise L = 0 Bit).</p> <p>Note 5: Resource blocks <math>n_{PRB} = 0..2</math> are allocated for SIB transmissions in sub-frame 5 for all bandwidths.</p> <p>Note 6: Resource blocks <math>n_{PRB} = 6..14,30..49</math> are allocated for the user data in all subframes.</p> <p>Note 7: Resource blocks <math>n_{PRB} = 3..49</math> are allocated for the user data in sub-frame 5, and resource blocks <math>n_{PRB} = 0..49</math> in sub-frames 0,3,4,6,7,8,9.</p> <p>Note 8: Resource blocks <math>n_{PRB} = 4..99</math> are allocated for the user data in sub-frame 5, and resource blocks <math>n_{PRB} = 0..99</math> in sub-frames 0,3,4,6,7,8,9.</p> <p>Note 9: Resource blocks <math>n_{PRB} = 4..71</math> are allocated for the user data in all sub-frames</p> <p>Note10: Given per component carrier per codeword.</p>						



## A.3.9.5 LAA

Table A.3.9.5-1: Fixed Reference Channel for sustained data-rate test (FS3 64QAM)

Parameter	Unit	Value					
		R.5 FS3	R.6 FS3	R.7 FS3	R.8 FS3	R.9 FS3	R.10 FS3
Reference channel							
Channel bandwidth	MHz	20	20	20	20	20	20
Allocated resource blocks		100	100	100	100	100	100
Modulation		64QAM	64QAM	64QAM	64QAM	64QAM	64QAM
Coding Rate							
For Sub-Frame 0		0.89	0.89	0.90	0.80	0.80	0.81
For Sub-Frame 1,2,3,4,6,7,8		0.88	0.88	0.88	0.79	0.79	0.79
For Sub-Frame 5		0.89	0.89	0.89	0.80	0.80	0.80
For Sub-Frame 9		N/A	0.77	0.88	N/A	0.82	0.79
Information Bit Payload (Note 7)							
For Sub-Frame 0		75376	75376	36696	128496	128496	61664
For Sub-Frames 1,2,3,4,6,7,8	Bits	75376	75376	75376	128496	128496	128496
For Sub-Frame 5	Bits	75376	75376	75376	128496	128496	128496
For Sub-Frame 9	Bits	N/A	55056	75376	N/A	110136	128496
Number of Code Blocks (Notes 3 and 6)							
For Sub-Frame 0		13	13	6	21	21	11
For Sub-Frames 1,2,3,4,6,7,8		13	13	13	21	21	21
For Sub-Frame 5		13	13	13	21	21	21
For Sub-Frame 9		N/A	9	13	N/A	18	21
Binary Channel Bits (Note 7)							
For Sub-Frame 0		85536	85536	40800	161472	161472	76800
For Sub-Frames 1,2,3,4,6,7,8	Bits	86400	86400	86400	163200	163200	163200
For Sub-Frame 5	Bits	85536	85536	85536	161472	161472	161472
For Sub-Frame 9	Bits	N/A	72000	86400	N/A	134400	163200
Number of layers		2	2	2	4	4	4
Max. Throughput averaged over 1 frame (Note 7)	Mbps	67.8384	73.3440	71.5080	115.6464	126.6600	121.8128
UE Categories		≥ 5	≥ 5	≥ 5	≥ 5	≥ 5	≥ 5
Note 1:	1 symbol allocated to PDCCH for all tests.						
Note 2:	Reference signal and synchronization signals are allocated as per TS 36.211 [4]. PBCH and SIBs are not allocated in FS3 cell.						
Note 3:	If more than one Code Block is present, an additional CRC sequence of L = 24 Bits is attached to each Code Block (otherwise L = 0 Bit).						
Note 4:	For R.5 FS3 and R.8 FS3, burst consists of 9 full subframes. Between two consecutive bursts, there is one subframe gap.						
Note 5:	For R.6 FS3 and R.9 FS3, burst consists of 9 full subframes and 1 ending partial subframe that has 12 OFDM symbols. Between two consecutive bursts, there is 2 OFDM symbol gap.						
Note 6:	For R.7 FS3 and R.10 FS3, burst consists of 1 initial partial subframe and 9 full subframes. Between two consecutive bursts, there is 7 OFDM symbol gap.						
Note 7:	Given per component carrier per codeword.						

Table A.3.9.5-2: Fixed Reference Channel for sustained data-rate test (FS3 256QAM)

Parameter	Unit	Value					
		R.11 FS3	R.12 FS3	R.13 FS3	R.14 FS3	R.15 FS3	R.16 FS3
Reference channel							
Channel bandwidth	MHz	20	20	20	20	20	20
Allocated resource blocks		100	100	100	100	100	100
Modulation		256QAM	256QAM	256QAM	256QAM	256QAM	256QAM
Coding Rate							
For Sub-Frame 0		0.75	0.75	0.81	0.79	0.79	0.77
For Sub-Frame 3,4,8		0.85	0.85	0.85	0.78	0.78	0.78
For Sub-Frame 1,2,6,7		0.75	0.74	0.74	0.78	0.78	0.78
For Sub-Frame 5		0.75	0.75	0.75	0.79	0.79	0.79
For Sub-Frame 9		N/A	0.79	0.85	N/A	0.74	0.78
Information Bit Payload (Note 7)							
For Sub-Frame 0		84760	84760	43816	169544	169544	78704
For Sub-Frame 3,4,8	Bits	97896	97896	97896	169544	169544	169544
For Sub-Frame 1,2,6,7	Bits	84760	84760	84760	169544	169544	169544
For Sub-Frame 5	Bits	84760	84760	84760	169544	169544	169544
For Sub-Frame 9	Bits	N/A	75376	97896	N/A	133208	169544
Number of Code Blocks (Notes 3 and 6)							
For Sub-Frame 0		14	14	8	28	28	13
For Sub-Frame 3,4,8		16	16	16	28	28	28
For Sub-Frame 1,2,6,7		14	14	14	28	28	28
For Sub-Frame 5		14	14	14	28	28	28
For Sub-Frame 9		N/A	13	16	N/A	21	28
Binary Channel Bits (Note 7)							
For Sub-Frame 0		114048	114048	54400	215296	215296	102400
For Sub-Frame 3,4,8	Bits	115200	115200	115200	217600	217600	217600
For Sub-Frame 1,2,6,7	Bits	115200	115200	115200	217600	217600	217600
For Sub-Frame 5	Bits	114048	114048	114048	215296	215296	215296
For Sub-Frame 9	Bits	N/A	96000	115200	N/A	179200	217600
Number of layers		2	2	2	4	4	4
Max. Throughput averaged over 1 frame (Note 7)	Mbps	80.2248	87.7624	85.9200	152.5896	165.9104	160.4600
UE DL Categories		≥ 11	≥ 11	≥ 11	≥ 11	≥ 11	≥ 11
Note 1:	1 symbol allocated to PDCCH for all tests.						
Note 2:	Reference signal and synchronization signals are allocated as per TS 36.211 [4]. PBCH and SIBs are not allocated in FS3 cell.						
Note 3:	If more than one Code Block is present, an additional CRC sequence of L = 24 Bits is attached to each Code Block (otherwise L = 0 Bit).						
Note 4:	For R.11 FS3 and R.14 FS3, burst consists of 9 full subframes. Between two consecutive bursts, there is one subframe gap.						
Note 5:	For R.12 FS3 and R.15 FS3, burst consists of 9 full subframes and 1 ending partial subframe that has 12 OFDM symbols. Between two consecutive bursts, there is 2 OFDM symbol gap.						
Note 6:	For R.13 FS3 and R.16 FS3, burst consists of 1 initial partial subframe and 9 full subframes. Between two consecutive bursts, there is 7 OFDM symbol gap.						
Note 7:	Given per component carrier per codeword.						

## A.3.10 Reference Measurement Channels for EPDCCH performance requirements

### A.3.10.1 FDD

**Table A.3.10.1-1: Reference Channel FDD**

Parameter	Unit	Value					
		R.55 FDD	R.56 FDD	R.57 FDD	R.58 FDD	R.59 FDD	R.55-1 FDD
Reference channel							
Number of transmitter antennas		2	2	2	2	2	2
Channel bandwidth	MHz	10	10	10	10	10	10
Number of OFDM symbols for PDCCH	symbols	2	2	1	1	1	2
Aggregation level	ECCE	4	16	2	8	2	4
DCI Format		2A	2A	2C	2C	2D	2C

### A.3.10.2 TDD

**Table A.3.10.2-1: Reference Channel TDD**

Parameter	Unit	Value					
		R.55 TDD	R.56 TDD	R.57 TDD	R.58 TDD	R.59 TDD	R.55 TDD
Reference channel							
Number of transmitter antennas		2	2	2	2	2	2
Channel bandwidth	MHz	10	10	10	10	10	10
Number of OFDM symbols for PDCCH	symbols	2	2	1	1	1	2
Aggregation level	CCE	4	16	2	8	2	4
DCI Format		2A	2A	2C	2C	2D	2C

## A.3.11 Reference Measurement Channels for MPDCCH performance requirements

### A.3.11.1 FDD and half-duplex FDD

**Table A.3.11.1-1: Reference Channel FDD and half-duplex FDD**

Parameter	Unit	Value		
		R.82 FDD	R.83 FDD	R.96 FDD
Reference channel				
Number of transmitter antennas		2	2	2
Channel bandwidth	MHz	10	10	10
OFDM starting symbol (startSymbolLC)	symbols	2	2	2
Aggregation level	ECCE	16	24	4
DCI Format		6-1A	6-1B	6-1A
Payload (without CRC)	Bits	29	18	29
PRB allocation		8-th ~11-th PRB	As specified in Test	8-th ~11-th PRB

## A.3.11.2 TDD

Table A.3.11.2-1: Reference Channel TDD

Parameter	Unit	Value	Value	Value
Reference channel		R.82 TDD	R.83 TDD	R.96 TDD
Number of transmitter antennas		2	2	2
Channel bandwidth	MHz	10	10	10
OFDM starting symbol (startSymbolLC)	symbols	2	2	2
Aggregation level	ECCE	16	24	4
DCI Format		6-1A	6-1B	6-1A
Payload (without CRC)	Bits	32	18	32
PRB allocation		8-th ~11-th PRB	As specified in Test	8-th ~11-th PRB

## A.3.12 Reference measurement channels for NPDSCH performance requirements

### A.3.12.1 In-band

#### A.3.12.1.2 Two-antenna transmission

**Table A.3.12.1.2-1: NPDSCH Reference Channel with 2 TX Antennas for FDD**

Parameter	Unit	Value	Value
Reference channel		R.NB.5 FDD	R.NB.5-1 FDD
Carrier Type		Anchor	Non-anchor
Channel bandwidth	KHz	200	200
Allocated subframes per Radio Frame		Note 2	Note 2
Modulation		QPSK	QPSK
$I_{\text{rs}}/I_{\text{sr}}$		4/0	4/0
Target Coding Rate		1/3	1/3
Coding Rate		0.4	0.4
Information Bit Payload			
For Sub-Frames 1,2,3,6,7,8	Bits	56	56
For Sub-Frame 0,5	Bits	N/A	56
For Sub-Frame 4,9	Bits	Note 3	56
Number of Code Blocks			
For Sub-Frames 1,2,3,6,7,8		1	1
For Sub-Frame 0,5	Bits	N/A	1
For Sub-Frame 4,9	Bits	Note 4	1
Binary Channel Bits			
For Sub-Frames 1,2,3,6,7,8	Bits	200	200
For Sub-Frame 0,5	Bits	N/A	200
For Sub-Frame 4,9	Bits	Note 5	200
Max. Averaged Throughput	Bps	Note 6	Note 6
UE Category		NB1,NB2	NB1,NB2
Note 1:	For in-band, the first 3 symbols are used for LTE PDCCH and the number of LTE CRS ports is 4.		
Note 2:	It shall depend on the specific NPDSCH scheduling.		
Note 3:	N/A when $n_f \bmod 2 = 0$ , otherwise 56.		
Note 4:	N/A when $n_f \bmod 2 = 0$ , otherwise 1.		
Note 5:	N/A when $n_f \bmod 2 = 0$ , otherwise 200.		
Note 6:	Maximum Average Throughput equals to sum of TB(i) divided by sum of T(i), where TB(i) is the TB size of NPDSCH over $i^{\text{th}}$ NPDSCH scheduling period, and T(i) is the total time consisting of NPDCCH transmission duration, NPDCCH to NPDSCH scheduling delay, NPDSCH transmission duration, NPDSCH to NPUSCH format 2 scheduling delay, NPUSCH format 2 transmission duration, possible delay between NPUSCH format 2 and NPDCCH for next NPDSCH scheduling and subframes used for NPSS/NSSS/NPBCH/NB-SIB1/NB-SIB2 transmission during the $i^{\text{th}}$ NPDSCH scheduling period.		

Table A.3.12.1.2-2: NPDSCH Reference Channel with 2 TX Antennas for TDD

Parameter	Unit	Value	Value
Reference channel		R.NB.5 TDD	R.NB.5-1 TDD
Carrier Type		Anchor	Non-anchor
Channel bandwidth	KHz	200	200
Uplink-Downlink Configuration (Note 7)		4	4
Allocated subframes per Radio Frame		Note 2	Note 2
Modulation		QPSK	QPSK
$I_{res}/I_{sf}$		4/0	4/0
Target Coding Rate		1/3	1/3
Coding Rate		0.4	0.4
Information Bit Payload			
For Sub-Frames 1,6,7,8	Bits	56	56
For Sub-Frame 5	Bits	N/A	Note 3
For Sub-Frame 9		N/A	56
For Sub-Frame 0	Bits	Note 3	Note 3
For Sub-Frame 4		Note 3	56
Number of Code Blocks			
For Sub-Frames 1,6,7,8		1	1
For Sub-Frame 5	Bits	N/A	Note 4
For Sub-Frame 9		N/A	1
For Sub-Frame 0	Bits	Note 4	Note 4
For Sub-Frame 4		Note 4	1
Binary Channel Bits			
For Sub-Frames 1,6,7,8	Bits	200	200
For Sub-Frame 5	Bits	N/A	Note 5
For Sub-Frame 9		N/A	200
For Sub-Frame 0	Bits	Note 5	Note 5
For Sub-Frame 4		Note 5	200
Max. Averaged Throughput	Bps	Note 6	Note 6
UE Category		NB1,NB2	NB1,NB2
Note 1:	For in-band, the first 3 symbols are used for LTE PDCCH and the number of LTE CRS ports is 4.		
Note 2:	It shall depend on the specific NPDSCH scheduling.		
Note 3:	N/A when $n_f \bmod 2 = 0$ , otherwise 56.		
Note 4:	N/A when $n_f \bmod 2 = 0$ , otherwise 1.		
Note 5:	N/A when $n_f \bmod 2 = 0$ , otherwise 200.		
Note 6:	Maximum Average Throughput equals to sum of TB(i) divided by sum of T(i), where TB(i) is the TB size of NPDSCH over $i^{\text{th}}$ NPDSCH scheduling period, and T(i) is the total time consisting of NPDCCH transmission duration, NPDCCH to NPDSCH scheduling delay, NPDSCH transmission duration, NPDSCH to NPUSCH format 2 scheduling delay, NPUSCH format 2 transmission duration, possible delay between NPUSCH format 2 and NPDCCH for next NPDSCH scheduling and subframes used for NPSS/NSSS/NPBCH/NB-SIB1/NB-SIB2 transmission during the $i^{\text{th}}$ NPDSCH scheduling period.		
Note 7:	As per Table 4.2-2 in TS 36.211 [4].		

## A.3.12.2 Standalone/Guard-band

## A.3.12.2.1 Single-antenna transmission

Table A.3.12.2.1-1: NPDSCH Reference Channel with 1Tx Antenna for UE Category NB1 and NB2 for FDD

Parameter	Unit	Value	Value
Reference channel		R.NB.6 FDD	R.NB.6-1 FDD
Carrier Type		Anchor	Non-anchor
Channel bandwidth	KHz	200	200
Allocated subframes per Radio Frame		Note 1	Note 1
Modulation		QPSK	QPSK
$T_{\text{res}}/T_{\text{SF}}$		9/3	6/3
Target Coding Rate		1/2	1/3
Coding Rate		0.5	0.33
Information Bit Payload			
For Sub-Frames 1,2,3,6,7,8	Bits	616	392
For Sub-Frame 0,5	Bits	N/A	392
For Sub-Frame 4,9	Bits	Note 2	392
Number of Code Blocks			
For Sub-Frames 1,2,3,6,7,8		1	1
For Sub-Frame 0,5	Bits	N/A	1
For Sub-Frame 4,9	Bits	Note 3	1
Binary Channel Bits			
For Sub-Frames 1,2,3,6,7,8	Bits	320	320
For Sub-Frame 0,5	Bits	N/A	320
For Sub-Frame 4,9	Bits	Note 4	320
Max. Average Throughput	Bps	Note 5	Note 5
UE Category		NB1,NB2	NB1,NB2
<p>Note 1: It shall depend on the specific NPDSCH scheduling.</p> <p>Note 2: N/A when <math>n_t \bmod 2 = 0</math>, otherwise 616.</p> <p>Note 3: N/A when <math>n_t \bmod 2 = 0</math>, otherwise 1.</p> <p>Note 4: N/A when <math>n_t \bmod 2 = 0</math>, otherwise 320.</p> <p>Note 5: Maximum Average Throughput equals to sum of TB(i) divided by sum of T(i), where TB(i) is the TB size of NPDSCH over <math>i^{\text{th}}</math> NPDSCH scheduling period, and T(i) is the total time consisting of NPDCCH transmission duration, NPDCCH to NPDSCH scheduling delay, NPDSCH transmission duration, NPDSCH to NPUSCH format 2 scheduling delay, NPUSCH format 2 transmission duration, possible delay between NPUSCH format 2 and NPDCCH for next NPDSCH scheduling and subframes used for NPSS/NSSS/NPBCH/NB-SIB1/NB-SIB2 transmission during the <math>i^{\text{th}}</math> NPDSCH scheduling period.</p>			

**Table A.3.12.2.1-1a: NPDSCH Reference Channel with 1Tx Antenna for UE Category NB1 and NB2 for TDD**

Parameter	Unit	Value	Value
Reference channel		R.NB.6 TDD	R.NB.6-1 TDD
Carrier Type		Anchor	Non-anchor
Channel bandwidth	KHz	200	200
Uplink-Downlink Configuration (Note 7)		4	4
Allocated subframes per Radio Frame		Note 1	Note 1
Modulation		QPSK	QPSK
$I_{BS}/I_{SF}$		9/3	6/3
Target Coding Rate		1/2	1/3
Coding Rate		0.5	0.33
Information Bit Payload			
For Sub-Frames 1,6,7,8	Bits	616	392
For Sub-Frame 5	Bits	N/A	Note 3
For Sub-Frame 9		N/A	392
For Sub-Frame 0	Bits	Note 2	Note 3
For Sub-Frame 4		Note 2	392
Number of Code Blocks			
For Sub-Frames 1,6,7,8		1	1
For Sub-Frame 5	Bits	N/A	Note 4
For Sub-Frame 9		N/A	1
For Sub-Frame 0	Bits	Note 4	Note 4
For Sub-Frame 4		Note 4	1
Binary Channel Bits			
For Sub-Frames 1,6,7,8	Bits	320	320
For Sub-Frame 5	Bits	N/A	Note 5
For Sub-Frame 9		N/A	320
For Sub-Frame 0	Bits	Note 5	Note 5
For Sub-Frame 4		Note 5	320
Max. Average Throughput	Bps	Note 6	Note 6
UE Category		NB1,NB2	NB1,NB2
Note 1:	It shall depend on the specific NPDSCH scheduling.		
Note 2:	N/A when $n_t \bmod 2 = 0$ , otherwise 616.		
Note 3:	N/A when $n_t \bmod 2 = 0$ , otherwise 392.		
Note 4:	N/A when $n_t \bmod 2 = 0$ , otherwise 1.		
Note 5:	N/A when $n_t \bmod 2 = 0$ , otherwise 320.		
Note 6:	Maximum Average Throughput equals to sum of TB(i) divided by sum of T(i), where TB(i) is the TB size of NPDSCH over $i^{\text{th}}$ NPDSCH scheduling period, and T(i) is the total time consisting of NPDCCH transmission duration, NPDCCH to NPDSCH scheduling delay, NPDSCH transmission duration, NPDSCH to NPUSCH format 2 scheduling delay, NPUSCH format 2 transmission duration, possible delay between NPUSCH format 2 and NPDCCH for next NPDSCH scheduling and subframes used for NPSS/NSSS/NPBCH/NB-SIB1/NB-SIB2 transmission during the $i^{\text{th}}$ NPDSCH scheduling period.		
Note 7:	As per Table 4.2-2 in TS 36.211 [4].		



Table A.3.12.2.1-2: NPDSCH Reference Channel with 1Tx Antenna for UE Category NB2 for FDD

Parameter	Unit	Value	Value
Reference channel		R.NB.7 FDD	R.NB.8 FDD
Carrier Type		Non-anchor	Non-anchor
Channel bandwidth	KHz	200	200
Allocated subframes per Radio Frame		Note 1	Note 1
Modulation		QPSK	QPSK
$I_{rs}/I_{sf}$		9/5	6/7
Target Coding Rate		1/2	1/3
Coding Rate		0.5	0.32
Information Bit Payload			
For Sub-Frames 1,2,3,6,7,8	Bits	936	1032
For Sub-Frame 0,5	Bits	936	1032
For Sub-Frame 4,9	Bits	936	1032
Number of Code Blocks			
For Sub-Frames 1,2,3,6,7,8		1	1
For Sub-Frame 0,5	Bits	1	1
For Sub-Frame 4,9	Bits	1	1
Binary Channel Bits			
For Sub-Frames 1,2,3,6,7,8	Bits	320	320
For Sub-Frame 0,5	Bits	320	320
For Sub-Frame 4,9	Bits	320	320
Max. Average Throughput	Bps	Note 2	Note 2
UE Category		NB2	NB2
<p>Note 1: It shall depend on the specific NPDSCH scheduling.</p> <p>Note 2: Maximum Average Throughput equals to sum of <math>TB(i)</math> divided by sum of <math>T(i)</math>, where <math>TB(i)</math> is the TB size of NPDSCH over <math>i^{th}</math> NPDSCH scheduling period, and <math>T(i)</math> is the total time consisting of NPDCCH transmission duration, NPDCCH to NPDSCH scheduling delay, NPDSCH transmission duration, NPDSCH to NPUSCH format 2 scheduling delay, NPUSCH format 2 transmission duration, possible delay between NPUSCH format 2 and NPDCCH for next NPDSCH scheduling and subframes used for NPSS/NSSS/NPBCH/NB-SIB1/NB-SIB2 transmission during the <math>i^{th}</math> NPDSCH scheduling period.</p>			

Table A.3.12.2.1-2a: NPDSCH Reference Channel with 1Tx Antenna for UE Category NB2 for TDD

Parameter	Unit	Value	Value
Reference channel		R.NB.7 TDD	
Carrier Type		Non-anchor	
Channel bandwidth	KHz	200	
Uplink-Downlink Configuration (Note 7)		4	
Allocated subframes per Radio Frame		Note 1	
Modulation		QPSK	
$I_{res}/I_{sf}$		9/5	
Target Coding Rate		1/2	
Coding Rate		0.5	
Information Bit Payload			
For Sub-Frames 1,6,7,8	Bits	936	
For Sub-Frame 0,5	Bits	Note 2	
For Sub-Frame 4,9	Bits	936	
Number of Code Blocks			
For Sub-Frames 1,2,3,6,7,8		1	
For Sub-Frame 0,5	Bits	Note 3	
For Sub-Frame 4,9	Bits	1	
Binary Channel Bits			
For Sub-Frames 1,2,3,6,7,8	Bits	320	
For Sub-Frame 0,5	Bits	Note 4	
For Sub-Frame 4,9	Bits	320	
Max. Average Throughput	Bps	Note 5	
UE Category		NB2	
Note 1:	It shall depend on the specific NPDSCH scheduling.		
Note 2:	N/A when $n_t \bmod 2 = 0$ , otherwise 936.		
Note 3:	N/A when $n_t \bmod 2 = 0$ , otherwise 1.		
Note 4:	N/A when $n_t \bmod 2 = 0$ , otherwise 320.		
Note 5:	Maximum Average Throughput equals to sum of TB(i) divided by sum of T(i), where TB(i) is the TB size of NPDSCH over $i^{\text{th}}$ NPDSCH scheduling period, and T(i) is the total time consisting of NPDCCH transmission duration, NPDCCH to NPDSCH scheduling delay, NPDSCH transmission duration, NPDSCH to NPUSCH format 2 scheduling delay, NPUSCH format 2 transmission duration, possible delay between NPUSCH format 2 and NPDCCH for next NPDSCH scheduling and subframes used for NPSS/NSSS/NPBCH/NB-SIB1/NB-SIB2 transmission during the $i^{\text{th}}$ NPDSCH scheduling period.		

### A.3.13 Reference measurement channels for NPDCCH performance requirements

#### A.3.13.1 Half-duplex FDD

Table A.3.13.1-1: NPDCCH Reference Channel for Category NB1 UE

Parameter	Unit	Value	
		R.NB.3 FDD	R.NB.4 FDD
Reference channel		R.NB.3 FDD	R.NB.4 FDD
Number of NRS ports		1	2
Channel bandwidth	MHz	0.2	0.2
Aggregation level	NCCE	2	2
DCI Format		N1	N1
Payload (without CRC)	Bits	23	23

## A.3.13.2 TDD

Table A.3.13.2-1: NPDCCH Reference Channel for Category NB1 UE

Parameter	Unit	Value	
		R.NB.3 TDD	R.NB.4 TDD
Reference channel		1	2
Number of NRS ports		1	2
Channel bandwidth	MHz	0.2	0.2
Aggregation level	NCCE	2	2
DCI Format		N1	N1
Payload (without CRC)	Bits	23	23

## A.3.14 Reference measurement channels for NPBCH performance requirements for Cat NB1 UEs

Table A.3.14-1: NPBCH Reference Channel for Category NB1 UE

Parameter	Unit	Value	
		R.NB.1	R.NB.2
Reference channel		1	2
Number of transmitter antennas		1	2
Channel bandwidth	KHz	200	200
Modulation		QPSK	QPSK
Target coding rate		50/1600	50/1600
Payload (without CRC)	Bits	34	34

## A.3.15 Reference Measurement Channels for LAA SCell with frame structure Type-3

### A.3.15.1 Multi-antenna transmission (Common Reference Symbols)

#### A.3.15.1.1 Four antenna ports

**Table A.3.15.1.1-2: Reference Channel with four CRS ports**

Parameter	Unit	Value
Reference channel		R.1 FS3
Channel bandwidth	MHz	20
Allocated resource blocks (Note 4)		100
Allocated subframes per Radio Frame		10
Modulation		64QAM
Target Coding Rate		0.6
Information Bit Payload (Note 4)		
For Sub-Frames 1,4,6,9	Bits	{46888,15840,24496,37888,19848}
For Sub-Frames 2, 7		{46888,15840,24496,37888,19848}
For Sub-Frames 3, 8		{46888,15840,24496,37888,19848}
For Sub-Frame 5	Bits	{46888,15840,24496,37888,19848}
For Sub-Frame 0	Bits	{46888,15840,24496,37888,19848}
Number of Code Blocks (Notes 3 and 4)		
For Sub-Frames 1,4,6,9		{8,3,4,7,4}
For Sub-Frames 2,7		{8,3,4,7,4}
For Sub-Frames 3, 8		{8,3,4,7,4}
For Sub-Frame 5		{8,3,4,7,4}
For Sub-Frame 0		{8,3,4,7,4}
Binary Channel Bits (Note 4)		
For Sub-Frames 1,4,6,9	Bits	{76800,26400,43200,62400,33600}
For Sub-Frames 2, 7		{76800,26400,43200,62400,33600}
For Sub-Frames 3, 8		{76800,26400,43200,62400,33600}
For Sub-Frame 5	Bits	{75936,26400,43200,61536,33600}
For Sub-Frame 0 (Note 5)	Bits	{75936,26400,43200,61536,33600}
UE Category		≥ 5
Note 1:	2 symbols allocated to PDCCH for 20 MHz, 15 MHz and 10 MHz channel BW; 3 symbols allocated to PDCCH for 5 MHz and 3 MHz; 4 symbols allocated to PDCCH for 1.4 MHz.	
Note 2:	Reference signal, synchronization signals and PBCH allocated as per TS 36.211 [4].	
Note 3:	If more than one Code Block is present, an additional CRC sequence of L = 24 Bits is attached to each Code Block (otherwise L = 0 Bit).	
Note 4:	Given per component carrier per codeword.	
Note 5:	For {a1,a2,a3,a4,a5}, a1, a2, a3, a4 and a5 stand for the setup when the number of OFDM symbols is 14, 6, 9, 12, 7, respectively.	

### A.3.15.2 Reference Measurement Channel for UE-Specific Reference Symbols

#### A.3.15.2.1 Two antenna ports (CSI-RS)

The reference measurement channels in Table A.3.15.2.1-1 apply for verifying demodulation performance for UE-specific reference symbols with two cell-specific antenna ports and two CSI-RS antenna ports for LAA SCell.

Table A.3.15.2.1-1: Reference Channel with two CRS ports

Parameter	Unit	Value
Reference channel		R.2 FS3
Channel bandwidth	MHz	20
Allocated resource blocks (Note 4)		100
Allocated subframes per Radio Frame		10
Modulation		16QAM
Target Coding Rate		1/2
Information Bit Payload (Note 4)		
For Sub-Frames 1,4,6,9	Bits	{22920,7480,12960,19080,10296}
For Sub-Frames 2, 7		{22920,7480,12960,19080,10296}
For Sub-Frames 3, 8		{22920,7480,12960,19080,10296}
For Sub-Frame 5	Bits	{19848, 6712, 11448, 16992, 9144}
For Sub-Frame 0	Bits	{19848, 6712, 11448, 16992, 9144}
Number of Code Blocks (Notes 3 and 4)		
For Sub-Frames 1,4,6,9		{4,2,3,4,2}
For Sub-Frames 2,7		{4,2,3,4,2}
For Sub-Frames 3, 8		{4, 2, 3, 4, 2}
For Sub-Frame 5		{4, 2, 2, 3, 2}
For Sub-Frame 0		{4, 2, 2, 3, 2}
Binary Channel Bits (Note 4)		
For Sub-Frames 1,4,6,9	Bits	{48000,15200,25600,38400,20000}
For Sub-Frames 2, 7		{47200,15200,25600,38400,20000}
For Sub-Frames 3, 8		{46400,15200,25600,38400,20000}
For Sub-Frame 5	Bits	{42240,13376,22528,33792,17600}
For Sub-Frame 0 (Note 5) (Note 6)	Bits	{42240,13376,22528,33792,17600}
UE Category		≥ 5
Note 1:	2 symbols allocated to PDCCH for 20 MHz, 15 MHz and 10 MHz channel BW; 3 symbols allocated to PDCCH for 5 MHz and 3 MHz; 4 symbols allocated to PDCCH for 1.4 MHz.	
Note 2:	Reference signal, synchronization signals and PBCH allocated as per TS 36.211 [4].	
Note 3:	If more than one Code Block is present, an additional CRC sequence of L = 24 Bits is attached to each Code Block (otherwise L = 0 Bit).	
Note 4:	Given per component carrier per codeword.	
Note 5:	For TM9, 100 resource blocks are allocated in sub-frames 1, 2, 3, 4, 6, 7, 8, 9 and 88 resource blocks (RB0-RB43,RB56-RB99) are allocated in subframe 0 and subframe 5	
Note 6:	For {a1,a2,a3,a4,a5}, a1, a2, a3, a4 and a5 stand for the setup when the number of OFDM symbols is 14, 6, 9, 12, 7, respectively	

Table A.3.15-2: Void

## A.3.16 Reference measurement channels for Slot-PDSCH and Subslot-PDSCH performance requirements

### A.3.16.1 FDD

**Table A.3.16.1-1: Fixed Reference Channel Slot-PDSCH (Cell-Specific Reference Signals)**

Parameter	Unit	
Reference channel		R.sTTI.1 FDD
Channel bandwidth	MHz	10
Allocated resource blocks		50
Allocated subframes per Radio Frame		8
Modulation		16QAM
Target Coding Rate		1/2
Information Bit Payload		
For Sub-Frames 1,2,3,4,6,7,8,9		
Slot index 0	Bits	11448
Slot index 1	Bits	14112
For Sub-Frames 0,5		N/A
Number of Code Blocks		
For Sub-Frames 1,2,3,4,6,7,8,9		
Slot index 0		2
Slot index 1		4
For Sub-Frame 0,5		N/A
Binary Channel Bits		
For Sub-Frames 1,2,3,4,6,7,8,9		
Slot index 0	Bits	22400
Slot index 1	Bits	28288
For Sub-Frame 0,5		N/A
Max. Throughput averaged over 1 frame	Mbps	20.448
UE Category		$\geq 2$
Note 1:	For an information bit payload first transmitted at slot 0, any retransmission happens only on slot 0. For an information bit payload first transmitted at slot 1, any retransmission happens on only slot 1.	

Table A.3.16.1-2: Fixed Reference Channel Subslot-PDSCH (Cell-Specific Reference Signals)

Parameter	Unit	
Reference channel		R.sTTI.2 FDD
Channel bandwidth	MHz	10
Allocated resource blocks		50
Allocated subframes per Radio Frame		8
Modulation		16QAM
Target Coding Rate		0.45
Information Bit Payload		
For Sub-Frames 1,2,3,4,6,7,8,9		
Subslot index 1	Bits	5160
Subslot index 2	Bits	3880
Subslot index 3	Bits	2664
Subslot index 4	Bits	3880
Subslot index 5	Bits	5160
For Sub-Frames 0,5		N/A
Number of Code Blocks		
For Sub-Frames 1,2,3,4,6,7,8,9		
Subslot index 1		1
Subslot index 2		1
Subslot index 3		1
Subslot index 4		1
Subslot index 5		1
For Sub-Frame 0,5		N/A
Binary Channel Bits		
For Sub-Frames 1,2,3,4,6,7,8,9		
Subslot index 1	Bits	12032
Subslot index 2	Bits	8832
Subslot index 3	Bits	5888
Subslot index 4	Bits	8832
Subslot index 5	Bits	12288
For Sub-Frame 0,5		N/A
Max. Throughput averaged over 1 frame	Mbps	16.5952
UE Category		≥2
Note 1: For an information bit payload first transmitted at subslot 1, any retransmission happens only on subslots 1 and 5. For an information bit payload first transmitted at subslot 2, any retransmission happens only on subslots 2 and 4. For an information bit payload first transmitted at subslot 3, any retransmission happens only on subslot 3. For an information bit payload first transmitted at subslot 4, any retransmission happens only on subslots 2 and 4. For an information bit payload first transmitted at subslot 5, any retransmission happens only on subslots 1 and 5.		

Table A.3.16.1-3: Fixed Reference Channel Slot-PDSCH (User-Specific Reference Signals)

Parameter	Unit	
Reference channel		R.sTTI.3 FDD
Channel bandwidth	MHz	10
Allocated resource blocks		50
Allocated subframes per Radio Frame		8
Modulation		QPSK
Target Coding Rate		1/3
Information Bit Payload		
For Sub-Frames 1,3,4,6,8,9		
Slot index 0	Bits	3624
Slot index 1	Bits	4392
For Sub-Frames 2,7		
Slot index 0	Bits	2856
Slot index 1	Bits	4392
For Sub-Frames 0,5		N/A
Number of Code Blocks		
For Sub-Frames 1,3,4,6,8,9		
Slot index 0		1
Slot index 1		1
For Sub-Frames 2,7		
Slot index 0		1
Slot index 1		1
For Sub-Frame 0,5		N/A
Binary Channel Bits		
For Sub-Frames 1,3,4,6,8,9		
Slot index 0	Bits	10000
Slot index 1	Bits	13360
For Sub-Frames 2,7		
Slot index 0	Bits	9600
Slot index 1	Bits	13360
For Sub-Frame 0,5		N/A
Max. Throughput averaged over 1 frame	Mbps	6.2592
UE Category		≥2
Note 1:	For an information bit payload first transmitted at slot 0, any retransmission happens only on slot 0. For an information bit payload first transmitted at slot 1, any retransmission happens only on slot 1.	



Table A.3.16.1-4: Fixed Reference Channel Subslot-PDSCH (User-Specific Reference Signals)

Parameter	Unit	
Reference channel		R.sTTI.4 FDD
Channel bandwidth	MHz	10
Allocated resource blocks		50
Allocated subframes per Radio Frame		8
Modulation		QPSK
Target Coding Rate		1/3
Information Bit Payload		
For Sub-Frames 1,3,4,6,8,9		
Subslot index 1	Bits	1736
Subslot index 2	Bits	1192
Subslot index 3	Bits	776
Subslot index 4	Bits	1192
Subslot index 5	Bits	1736
For Sub-Frames 2,7		
Subslot index 1	Bits	1736
Subslot index 2	Bits	1192
Subslot index 3	Bits	776
Subslot index 4	Bits	1192
Subslot index 5	Bits	1736
For Sub-Frames 0,5		N/A
Number of Code Blocks		
For Sub-Frames 1,3,4,6,8,9		
Subslot index 1		1
Subslot index 2		1
Subslot index 3		1
Subslot index 4		1
Subslot index 5		1
For Sub-Frames 2,7		
Subslot index 1		1
Subslot index 2		1
Subslot index 3		1
Subslot index 4		1
Subslot index 5		1
For Sub-Frame 0,5		N/A
Binary Channel Bits		
For Sub-Frames 1,3,4,6,8,9		
Subslot index 1	Bits	4960
Subslot index 2	Bits	4032
Subslot index 3	Bits	2688
Subslot index 4	Bits	4032
Subslot index 5	Bits	5088
For Sub-Frames 2,7		
Subslot index 1	Bits	4960
Subslot index 2	Bits	3696
Subslot index 3	Bits	2688
Subslot index 4	Bits	4032
Subslot index 5	Bits	5088
For Sub-Frame 0,5		N/A
Max. Throughput averaged over 1 frame	Mbps	5.3056
UE Category		≥2
Note 1:	For an information bit payload first transmitted at subslot 1, any retransmission happens only on subslots 1 and 5. For an information bit payload first transmitted at subslot 2, any retransmission happens only on subslots 2 and 4. For an information bit payload first transmitted at subslot 3, any retransmission happens only on subslot 3. For an information bit payload first transmitted at subslot 4, any retransmission happens only on subslots 2 and 4. For an information bit payload first transmitted at subslot 5, any retransmission happens only on subslots 1 and 5.	
Note 2:	In any retransmission, no information bit payloads are scheduled at subslot #n when information bit payloads are not scheduled at subslot #(n-1).	

## A.3.16.2 TDD

Table A.3.16.2-1: Fixed Reference Channel Slot-PDSCH (Cell-Specific Reference Signals)

Parameter	Unit	
Reference channel		R.sTTI.1 TDD
Channel bandwidth	MHz	10
Allocated resource blocks		50
Uplink-Downlink Configuration		1
Allocated subframes per Radio Frame (D)		2
Modulation		16QAM
Target Coding Rate		1/2
Information Bit Payload		
For Sub-Frames 4,9		
Slot index 0	Bits	11448
Slot index 1	Bits	14112
For Sub-Frames 0,1,5,6		N/A
Number of Code Blocks		
For Sub-Frames 4,9		
Slot index 0		2
Slot index 1		4
For Sub-Frames 0,1,5,6		N/A
Binary Channel Bits		
For Sub-Frames 4,9		
Slot index 0	Bits	22400
Slot index 1	Bits	28288
For Sub-Frame 0,1,5,6		N/A
Max. Throughput averaged over 1 frame	Mbps	5.112
UE Category		$\geq 2$
Note 1: For an information bit payload first transmitted at slot 0, any retransmission happens only on slot 0. For an information bit payload first transmitted at slot 1, any retransmission happens only on slot 1.		

Table A.3.16.2-2: Fixed Reference Channel Slot-PDSCH (User-Specific Reference Signals)

Parameter	Unit	
Reference channel		R.sTTI.2 TDD
Channel bandwidth	MHz	10
Allocated resource blocks		50
Uplink-Downlink Configuration		1
Allocated subframes per Radio Frame (D)		2
Modulation		QPSK
Target Coding Rate		1/3
Information Bit Payload		
For Sub-Frames 4,9		
Slot index 0	Bits	2856
Slot index 1	Bits	4392
For Sub-Frames 0,1,5,6		N/A
Number of Code Blocks		
For Sub-Frames 4,9		
Slot index 0		1
Slot index 1		1
For Sub-Frames 0,1,5,9		N/A
Binary Channel Bits		
For Sub-Frames 4,9		
Slot index 0	Bits	9600
Slot index 1	Bits	13360
For Sub-Frame 0,1,5,6		N/A
Max. Throughput averaged over 1 frame	Mbps	1.4496
UE Category		≥2
Note 1: For an information bit payload first transmitted at slot 0, any retransmission happens only on slot 0. For an information bit payload first transmitted at slot 1, any retransmission happens only on slot 1.		

## A.3.17 Reference measurement channels for SPDCCH performance requirements

### A.3.17.1 FDD

Table A.3.17.1-1: Reference Channel FDD

Parameter	Unit	R.sTTI.10 FDD	R.sTTI.11 FDD
Reference channel			
Number of transmitter antennas		4	2
Channel bandwidth	MHz	10	10
Aggregation level	SCCE	2	8
DCI Format		7-1C	7-1F
Cell ID		0	0
Payload (without CRC)	Bits	32	28

## A.3.17.2 TDD

**Table A.3.17.2-1: Reference Channel TDD**

Parameter	Unit	R.sTTI.10 TDD	R.sTTI.11 TDD
Reference channel			
Number of transmitter antennas		4	2
Channel bandwidth	MHz	10	10
Aggregation level	SCCE	2	8
DCI Format		7-1C	7-1F
Cell ID		0	0
Payload (without CRC)	Bits	34	30

---

## A.4 CSI reference measurement channels

This section defines the DL signal applicable to the reporting of channel status information (Clause 9.2, 9.3 and 9.5).

In Table A.4-1 are specified the reference channels. Table A.4-13 specifies the mapping of CQI index to modulation coding scheme, which complies with the CQI definition specified in Section 7.2.3 of [6].

**Table A.4-0: Void**

**Table A.4-1: CSI reference measurement channels**

RMC Name	Duplex	CH-BW	Alloc. RB-s	UL/DL Config	Alloc. SF-s	MCS Scheme	Nr. HARQ Proc.	Max. nr HARQ Trans.	Notes
<b>1 CRS Port</b>									
RC.1 FDD	FDD	10	50	-		MCS.1	8	1	
RC.1A FDD	FDD	10	50			MCS.1A	8	1	
RC.1 TDD	TDD	10	50	Note 3		MCS.1	10	1	
RC.1A TDD	TDD	20	100	Note 3		MCS.1B	10	1	
RC.3 FDD	FDD	10	6	-		MCS.10	8	1	
RC.3 TDD	TDD	10	6	Note 3		MCS.10	10 or 7 (Note 9)	1	
RC.4 FDD	FDD	10	15	-		MCS.15	8	1	Note 6
RC.4 TDD	TDD	10	15	Note 3		MCS.15	10	1	Note 6
RC.5 FDD	FDD	10	3	-		MCS.17	8	1	
RC.5 TDD	TDD	10	3	Note 3		MCS.17	10	1	
RC.14 FDD	FDD	5	25	-		MCS.14	8	1	
RC.15 FDD	FDD	5	15	-		MCS.15	8	1	Note 6
RC.16 FDD	FDD/HD-FDD	10	2			MCS.20	8	1	Note 8,10
RC.16 TDD	TDD	10	2	Note 3		MCS.20	10	1	Note 8
RC.23 FDD	FDD/HD-FDD	10	3			MCS.28	8	1	Note 12, 13
RC.23 TDD	TDD	10	3			MCS.28	10	1	Note 12
RC.25 FDD	FDD/HD-FDD	10	3			MCS.28	8	1	Note 14, 20
RC.25 TDD	TDD	10	3			MCS.28	10	1	Note 12, 15
RC.31 FDD	FDD/HD-FDD	10	3			MCS.40	8	1	Note 12, 13
RC.31 TDD	TDD	10	3			MCS.40	10	1	Note 12
RC.32 FDD	FDD/HD-FDD	10	3			MCS.41	8	1	Note 12, 13
RC.32 TDD	TDD	10	3			MCS.41	10	1	Note 12
RC.30 FDD	FDD	10	50			MCS.38	8	1	
RC.30 TDD	TDD	20	100			MCS.39	10	1	
<b>2 CRS Ports</b>									
RC.2 FDD	FDD	10	50	-		MCS.2	8	1	
RC.2A FDD	FDD	20	100			MCS.2A	8	1	
RC.2 TDD	TDD	10	50	Note 3		MCS.2	10 or 7 (Note 9)	1	
RC.4A FDD	FDD	20	15	-		MCS.16	8	1	Note 6
RC.6 FDD	FDD	10	15	-		MCS.16	8	1	Note 6
RC.6 TDD	TDD	10	15	Note 3		MCS.16	7	1	Note 6
<b>4 CRS Ports</b>									
RC.17 FDD	FDD	10	50	-		MCS.18	8	1	
RC.17 TDD	TDD	10	50	Note 3		MCS.18	7	1	
RC.21 FDD	FDD	10	50	-		MCS.26	8	1	
RC.21 TDD	TDD	10	50	Note 3		MCS.26	7	1	
<b>1 CRS Port + CSI-RS</b>									

RC.8 FDD	FDD	10	6	-	Non CSI-RS	MCS.11	8	1	
					2 CSI-RS	MCS.12			
RC.8A FDD	FDD	10	6	-	Non CSI-RS	MCS.11A	8	1	
					2 CSI-RS	MCS.12A			
RC.8 TDD	TDD	10	6	Note 3	Non CSI-RS	MCS.11	10	1	
					2 CSI-RS	MCS.12			
RC.8A TDD	TDD	20	8	Note 3	Non CSI-RS	MCS.11B	10	1	
					2 CSI-RS	MCS.12B			
RC.9 FDD	FDD	10	50	-	Non CSI-RS	MCS.3	8	1	
					2 CSI-RS	MCS.4			
RC.9A FDD	FDD	20	100	-	Non CSI-RS	MCS.3A	8	1	
					2 CSI-RS	MCS.4A			
RC.9B FDD	FDD	10	50	-	Non CSI-RS, rank 1/2	MCS.3	8	1	
					Non CSI-RS, rank 3/4	MCS.30			
					4 CSI-RS, rank 1/2	MCS.29			
					4 CSI-RS, rank 3/4	MCS.31			
RC.9 TDD	TDD	10	50	Note 3	Non CSI-RS	MCS.3	7	1	
					2 CSI-RS	MCS.4			
RC.9B TDD	TDD	10	50	Note 3	Non CSI-RS, rank 1/2	MCS.3	7	1	
					Non CSI-RS, rank 3/4	MCS.30			
					4 CSI-RS, rank 1/2	MCS.29			
					4 CSI-RS, rank 3/4	MCS.31			
<b>2 CRS Port + CSI-RS</b>									
RC.7 FDD	FDD	10	50	-	Non CSI-RS	MCS.5	8	1	
					4 CSI-RS	MCS.7			
RC.7 TDD	TDD	10	50	Note 3	Non CSI-RS	MCS.5	10	1	
					8 CSI-RS	MCS.8			
RC.11 FDD	FDD	10	50	-	Non CSI-RS	MCS.5	8	1	
					2 CSI-RS	MCS.6			
RC.11 TDD	TDD	10	50	Note 3	Non CSI-RS	MCS.5	10	1	
					2 CSI-RS	MCS.6			
RC.18 FDD	FDD	10	6	-	Non CSI-RS	MCS.13	8	1	
					4 CSI-RS	MCS.19			
RC.18 TDD	TDD	10	6	Note 3	Non CSI-RS	MCS.13	7	1	
					4 CSI-RS	MCS.19			
RC.17 TDD	TDD	10	6	Note 3	4 ZP-CSI-RS	MCS.21	10	1	
RC.18 TDD	TDD	10	6	Note 3	4 ZP-CSI-RS	MCS.22	10	1	
RC.19 TDD	TDD	10	41	Note3	4 ZP-CSI-RS	MCS.23	10	1	Note 11

RC.20 TDD	TDD	10	50	Note3	Non CSI-RS	MCS.24	10	1	
					2 CSI-RS, 4 ZP-CSI- RS	MCS.25			
RC.22 FDD	FDD	10	50	-	Non CSI-RS	MCS.5	8	1	
					4 CSI-RS	MCS.27			
RC.22 TDD	TDD	10	50	Note 3	Non CSI-RS	MCS.5	10	1	
					4 CSI-RS	MCS.27			
RC.23 TDD	TDD	10	50	Note 3	Non CSI-RS	MCS.9	10	1	Rank 4
					4 CSI-RS	MCS.32			
<b>1 CRS Port + CSI-RS + CSI-IM</b>									
RC.13 FDD	FDD	10	50	-	Non CSI- RS/IM	MCS.3	8	1	
					CSI- RS/IM	N/A			
RC.13 TDD	TDD	10	50	Note 3	Non CSI- RS/IM	MCS.3	10	1	
					CSI- RS/IM	N/A			
<b>2 CRS Port + CSI-RS + CSI-IM</b>									
RC.10 FDD	FDD	10	50	-	Non CSI-RS	MCS.5	8	1	
					4 CSI- RS, 1 CSI process	MCS.8			
RC.10 TDD	TDD	10	50	Note 3	Non CSI-RS	MCS.5	10	1	
					8 CSI- RS, 1 CSI process	MCS.9			
RC.12 FDD	FDD	10	6	-	Non CSI- RS/IM	MCS.13	8	1	
					CSI- RS/IM	N/A			
RC.12 TDD	TDD	10	6	Note 3	Non CSI- RS/IM	MCS.13	10	1	
					CSI- RS/IM	N/A			
<b>Short TTI</b>									
RC.26 FDD	FDD	10	50	-	-	MCS.32-1 MCS.32-2	8	1	Note 2
RC.27 FDD	FDD	10	50	-	Non CSI-RS	MCS.33-1 MCS.33-2	8	1	Note 2
	FDD	10	50	-	2 CSI-RS	MCS.34-1 MCS.34-2	8	1	Note 2
RC.28 FDD	FDD	10	50	-	-	MCS.35-1 MCS.35-2 MCS.35-3 MCS.35-4 MCS.35-5	16	1	Note 2 Note 17 Note 18
RC.29 FDD	FDD	10	50	-	Non CSI-RS	MCS.36-1 MCS.36-2 MCS.36-3 MCS.36-4 MCS.36-5	16	1	Note 2 Note 17 Note 19
	FDD	10	50	-	2 CSI-RS	MCS.37-1 MCS.37-2 MCS.37-3 MCS.37-4 MCS.37-5	16	1	Note 2 Note 17 Note 19
RC.26 TDD	TDD	10	50	-	-	MCS.32-1 MCS.32-2	10	1	Note 5
RC.27 TDD	TDD	10	50	-	Non CSI-RS	MCS.33-1 MCS.33-2	16	1	Note 5
	TDD	10	50	-	2 CSI-RS	MCS.34-1 MCS.34-2	16	1	Note 5



- Note 1: 3 symbols allocated to PDCCH.
- Note 2: For FDD only subframes 1, 2, 3, 4, 6, 7, 8 and 9 are allocated to avoid PBCH and synchronization signal overhead.
- Note 3: TDD UL-DL configuration as specified in the individual tests.
- Note 4: For TDD when UL-DL configuration 1 is used only subframes 4 and 9 are allocated to avoid PBCH and synchronization signal overhead.
- Note 5: For TDD when UL-DL configuration 2 is used only subframes 3, 4, 8, and 9 are allocated to avoid PBCH and synchronization signal overhead.
- Note 6: Centered within the Transmission Bandwidth Configuration (Figure 5.6-1).
- Note 7: Only subframes 2, 3, 4, 7, 8 and 9 are allocated to avoid PBCH and synchronization signal overhead.
- Note 8: Allocate PDSCH on 5th and 6th PRBs within a subband.
- Note 9: The number of HARQ processes is 10 for TDD UL/DL configuration 2 and 7 for TDD UL/DL configuration 1.
- Note 10: The downlink subframes are scheduled at the 1st, 2nd, 8th, 9th, 16th, 17th, 18th, 24th, 26th, 32nd, 33rd, 34th subframes every 40ms. Information bit payload is available if downlink subframe is scheduled. (starting from 0th subframe)
- Note 11: 41 resource blocks (RB0–RB20 and RB30–RB49) are allocated in subframe 0 and 5 in RC.19 TDD.
- Note 12: Allocate PDSCH on 3th, 4th and 5th PRBs within a narrowband. Allocate MPDCCH on the 0th and 1st PRBs within a narrowband.
- Note 13: The PDSCH subframes are scheduled at the 0th and 1st subframes every 10ms. Information bit payload is available if downlink subframe is scheduled (starting from 0th subframe). MPDCCH subframes are scheduled at the 8th and 9th subframes every 10ms.
- Note 14: The downlink subframes are scheduled at the 0th to 4th subframes every 20ms. Information bit payload is scheduled at the 4th subframe (starting from 0th subframe). MPDCCH and Information bit payload are not scheduled in the radio frames where systemInformation1-BR is scheduled and
- $$N_{\text{PDSCH}}^{\text{SIB1-BR}} = 4$$
- with the set of frames and subframes for SIB1-BR defined in TS 36.211 [16] Table 6.4.1-2.
- Note 15: Information bit payload is scheduled at the 8th subframe every 20ms (starting from 0th subframe).
- Note 16: 2 symbols allocated for PDCCH.
- Note 17: No PDSCH is scheduled in subslot index 0.
- Note 18: Subslot-PDSCH is scheduled in subslots 2, 3, and 4.
- Note 19: Subslot-PDSCH is scheduled in subslots 1 and 5.
- Note 20: Allocate PDSCH on 3th, 4th and 5th PRBs within a narrowband. Allocate MPDCCH on the 0th, 1st, 2nd and 3rd PRBs within a narrowband.

**Table A.4-1a: Void**

**Table A.4-1b: Void**

**Table A.4-1c: Void**

**Table A.4-1d: Void**

**Table A.4-1e: Void**

**Table A.4-2: Void**

**Table A.4-2a: Void**

**Table A.4-2b: Void**

**Table A.4-2c: Void**

**Table A.4-2d: Void**

**Table A.4-2e: Void**

**Table A.4-3: Void**

**Table A.4-3a: Void**

**Table A.4-3b: Void**

**Table A.4-3c: Void**

**Table A.4-3d: Void**

**Table A.4-3e: Void**

**Table A.4-3f: Void**

**Table A.4-3g: Void**

**Table A.4-3h: Void**

**Table A.4-3i: Void**

**Table A.4-3j: Void**

**Table A.4-3k: Void**

**Table A.4-3l: Void**

**Table A.4-3m: Void**

**Table A.4-4: Void**

**Table A.4-4a: Void**

**Table A.4-4b: Void**

**Table A.4-5: Void**

**Table A.4-5a: Void**

*ETSI*

**Table A.4-5b: Void**

**Table A.4-6: Void**

**Table A.4-6a: Void**

**Table A.4-6b: Void**

**Table A.4-6c: Void**

**Table A.4-6d: Void**

**Table A.4-6e: Void**

**Table A.4-6f: Void**

**Table A.4-7: Void**

**Table A.4-8: Void**

**Table A.4-9: Void**

**Table A.4-10: Void**

**Table A.4-11: Void**

**Table A.4-12: Void**

Table A.4-13: Mapping of CQI Index to Modulation coding scheme (MCS)

CQI Index			0	1	2	3	4	5	6	7	8	9	10	11	12	13	14	15	Notes	
Target Coding Rate			OOOR	0.0762	0.1172	0.1885	0.3008	0.4385	0.5879	0.8691	0.4785	0.6016	0.4551	0.5537	0.6504	0.7539	0.8525	0.9256		
Modulation			OOOR	QPSK						16QAM			64QAM							
MCS Scheme	PRB	Available RE-s	Imcs																	
MCS.1	50	6300	DTX	0	0	2	4	6	8	11	13	16	18	21	23	25	27	27		
MCS.2	50	6000	DTX	0	0	2	4	6	8	11	13	15	18	20	22	24	26	27		
MCS.2A	100	12000	DTX	0	0	2	4	6	8	11	13	15	18	20	22	24	26	27		
MCS.3	50	5700	DTX	0	0	2	4	6	8	10	13	15	17	19	21	23	25	26		
MCS.3A	100	11400	DTX	0	0	2	4	6	8	11	13	15	17	19	21	23	25	26		
MCS.4	50	5600	DTX	0	0	2	4	6	7	10	12	14	17	19	21	23	25	26		
MCS.4A	100	11200	DTX	0	0	2	4	6	7	10	12	14	17	19	21	23	25	26		
MCS.5	50	5400	DTX	0	0	2	3	5	7	10	12	14	17	19	21	23	24	25		
MCS.6	50	5300	DTX	0	0	1	3	5	7	10	12	14	17	19	21	22	24	25		
MCS.7	50	5200	DTX	0	0	1	3	5	7	10	12	14	17	18	20	22	24	25		
MCS.8	50	5000	DTX	0	0	1	3	5	7	10	12	13	17	18	20	22	23	24		
MCS.9	50	4800	DTX	0	0	1	3	5	7	10	12	13	17	18	20	22	23	24		
MCS.10	6	756	DTX	0	0	2	4	6	8	11	13	16	19	21	23	25	27	27		
MCS.11	6	684	DTX	0	0	2	4	6	8	11	13	14	17	20	21	23	25	27		
MCS.12	6	672	DTX	0	0	1	4	6	8	10	12	14	17	19	21	23	25	26		
MCS.13	6	648	DTX	0	0	1	3	5	7	10	12	14	17	19	21	22	24	25		
MCS.14	25	3150	DTX	0	0	2	4	6	8	11	13	16	18	21	23	25	27	27		
MCS.15	15	1890	DTX	0	0	2	4	6	8	11	13	16	18	21	23	25	27	27		
MCS.16	15	1800	DTX	0	0	2	4	6	8	11	13	15	18	20	22	24	26	27		
MCS.17	3	378	DTX	0	1	2	5	7	9	12	13	16	19	21	23	25	27	27		
MCS.18	50	5800	DTX	0	0	2	4	6	8	11	13	15	17	20	22	23	26	27		
MCS.19	6	624	DTX	0	0	1	3	5	7	10	12	14	17	18	20	22	24	25		
MCS.20	2	252	DTX	0	0	2	4	6	8	11	13	16	19	21	23	23	23	23		
MCS.21	6	696	DTX	0	0	2	4	6	8	11	13	15	18	20	21	24	25	27		
MCS.22	6	624	DTX	0	0	1	3	5	7	10	12	14	15	19	20	22	24	24		
MCS.23	41	4264	DTX	0	0	1	3	5	7	10	12	14	15	18	20	22	24	24		
MCS.24	50	5400	DTX	0	0	2	3	5	7	10	12	14	15	19	21	23	24	25		
MCS.25	50	5100	DTX	0	0	1	3	5	7	8	12	13	15	18	20	22	23	24		
MCS.26	50	5800	DTX	0	0	2	4	6	8	11	13	15	18	20	22	24	26	27		
MCS.27	CW0	50	4600	DTX	0	0	1	3	5	6	10	11	13	17	18	19	21	23	23	
	CW1	50	4600	DTX	0	0	1	3	5	6	10	11	13	17	18	19	21	22	23	
MCS.29	50	5500	DTX	0	0	2	3	5	7	10	12	14	15	19	21	23	24	25		
MCS.30	50	10200	DTX	0	0	1	3	5	7	8	12	14	15	18	20	22	23	24		
MCS.31	50	9800	DTX	0	0	1	3	5	7	8	11	13	14	18	20	21	23	23		
MCS.32	50	4600	DTX	0	0	1	3	5	6	10	11	13	17	18	19	21	22	23	2Layer1CW	

Note 1: Mapping between Imcs and TBS according to Tables 7.1.7.1-1 and 7.1.7.2.1-1 in TS 36.213 [6].  
 Note 2: 3 symbols allocated to PDCCH.  
 Note 3: Sub-frame#0 and #5 are not used for the corresponding requirement except for [MCS.23]. The next subframe (i.e. sub-frame#1 or #6) shall be used for potential retransmissions.

**Table A.4-14: Mapping of CQI Index to Modulation coding scheme (Modulation and TBS index Table 2 and 4-bit CQI Table 2 are used)**

CQI Index			0	1	2	3	4	5	6	7	8	9	10	11	12	13	14	15	Notes
Target Spectral Efficiency			OOR	0.1523	0.3770	0.8770	1.4766	1.9141	2.4063	2.7305	3.3223	3.9023	4.5234	5.1152	5.5547	6.2266	6.9141	7.4063	
MCS Scheme	PRB	Available RE-s	Imcs																
MCS.1A	50	6300	DTX	0	1	3	5	7	10	11	14	16	18	20	22	24	26	26	
MCS.1B	100	12600	DTX	0	1	3	5	7	10	11	14	15	18	20	22	24	26	26	
Note 1: Mapping between Imcs and CQI Index according to Tables 7.1.7.1-1A, 7.1.7.2.1-1 and 7.2.3-2 in TS 36.213 [6]. Note 2: 3 symbols allocated to PDCCCH. Note 3: Sub-frame#0 and #5 are not used for the corresponding requirement. The next subframe (i.e. sub-frame#1 or #6) shall be used for potential retransmissions.																			

**Table A.4-15: Mapping of CQI Index to Modulation coding scheme (Modulation and TBS index Table 2 and 4-bit CQI Table 2 are used)**

CQI Index			0	1	2	3	4	5	6	7	8	9	10	11	12	13	14	15	Notes
Target Spectral Efficiency			OOR	0.1523	0.3770	0.8770	1.4766	1.9141	2.4063	2.7305	3.3223	3.9023	4.5234	5.1152	5.5547	6.2266	6.9141	7.4063	
MCS Scheme	PRB	Available RE-s	Imcs																
MCS.11A	6	684	DTX	0	1	3	5	7	8	10	13	14	16	18	20	22	24	25	
MCS.12A	6	672	DTX	0	1	3	5	6	8	10	12	14	16	18	20	22	24	25	
MCS.11B	8	912	DTX	0	1	3	5	7	9	10	13	14	16	18	19	22	24	26	
MCS.12B	8	896	DTX	0	1	3	5	6	8	10	12	14	16	18	19	22	24	25	
Note 1: Mapping between Imcs and CQI Index according to Tables 7.1.7.1-1A, 7.1.7.2.1-1 and 7.2.3-2 in TS 36.213 [6]. Note 2: 3 symbols allocated to PDCCCH. Note 3: Sub-frame#0 and #5 are not used for the corresponding requirement. The next subframe (i.e. sub-frame#1 or #6) shall be used for potential retransmissions.																			

**Table A.4-16: Mapping of CQI Index to Modulation coding scheme (Modulation and TBS index Table 3)**

CQI Index			0	1	2	3	4	5	6	7	8	9	10	11	12	13	14	15	Notes
Target Coding Rate			OOR	0.0391	0.0762	0.1172	0.1885	0.3008	0.4385	0.5879	0.3691	0.4785	0.6015	Reserved	Reserved	Reserved	Reserved	Reserved	
Modulation			OOR	QPSK									16QAM						
MCS Scheme	PRB	Available RE-s	Imcs																
MCS.28	3	378	DTX	0	0	0	2	4	6	8	11	13	15	N/A	N/A	N/A	N/A	N/A	
Note 1: Mapping between Imcs and TBS according to Tables 7.1.7.1-1 and 7.1.7.2.1-1 in TS 36.213 [6]. Note 2: startSymbolBR = 3																			

**Table A.4-17: Mapping of CQI Index to Modulation coding scheme (Slot-PDSCH)**

CQI Index				0	1	2	3	4	5	6	7	8	9	10	11	12	13	14	15	Notes
Target Spectral Efficiency				OOB	0.1523	0.2344	0.3770	0.6016	0.8770	1.1758	1.4766	1.9141	2.4063	2.7305	3.3223	3.9023	4.5234	5.1152	5.5547	
MCS Scheme	PRB	Available RE-s	Slot number	Imcs																
MCS.32-1	50	2800	0	DTX	0	0	2	4	6	7	10	12	14	17	19	21	23	25	26	Slot 0
MCS.32-2	50	3672	1	DTX	0	1	3	5	7	9	13	15	16	20	23	25	27	28	28	Slot 1
MCS.33-1	50	2600	0	DTX	0	0	1	3	5	7	10	12	14	17	18	20	22	24	25	Slot 0
MCS.33-2	50	3348	1	DTX	0	0	2	4	7	9	12	14	16	19	21	23	26	27	28	Slot 1
MCS.34-1	50	2500	0	DTX	0	0	1	3	5	7	10	12	13	17	18	20	22	23	24	Slot 0
MCS.34-2	50	3348	1	DTX	0	0	2	4	7	9	12	14	16	19	21	23	26	27	28	Slot 1

Note 1: Mapping between Imcs and CQI Index according to Tables 7.1.7.1-1 in TS 36.213 [6].  
 Note 2: Sub-frame#0 and #5 are not used for the corresponding requirement. The next subframe (i.e. sub-frame#1 or #6) shall be used for potential retransmissions.

**Table A.4-18: Mapping of CQI Index to Modulation coding scheme (Subslot-PDSCH)**

CQI Index				0	1	2	3	4	5	6	7	8	9	10	11	12	13	14	15	Notes
Target Spectral Efficiency				OOR	0.1523	0.2344	0.3770	0.6016	0.8770	1.1758	1.4766	1.9141	2.4063	2.7305	3.3223	3.9023	4.5234	5.1152	5.5547	
MCS Scheme	PRB	Available RE-s	Subslot number	Imcs																
MCS.35-1	50	1408	1	DTX	0	1	3	6	8	9	14	16	16	22	24	27	28	28	28	Subslot 1
MCS.35-2	50	1008	2	DTX	0	0	2	4	6	8	11	13	15	18	20	22	24	26	27	Subslot 2
MCS.35-3	50	872	3	DTX	0	0	1	3	5	7	10	12	14	17	18	20	22	24	25	Subslot 3
MCS.35-4	50	1008	4	DTX	0	0	2	4	6	8	11	13	15	18	20	22	24	26	27	Subslot 4
MCS.35-5	50	1472	5	DTX	0	1	3	6	9	9	14	16	16	22	25	27	28	28	28	Subslot 5
MCS.36-1	50	1180	1	DTX	0	0	2	5	7	9	12	14	16	19	22	24	27	28	28	Subslot 1
MCS.36-2	50	680	2	DTX	0	0	0	2	4	5	10	10	12	17	17	17	19	20	22	Subslot 2
MCS.36-3	50	612	3	DTX	0	0	0	2	3	5	10	10	11	17	17	17	18	19	20	Subslot 3
MCS.36-4	50	680	4	DTX	0	0	0	2	4	5	10	10	12	17	17	17	19	20	20	Subslot 4
MCS.36-5	50	1212	5	DTX	0	1	3	5	7	9	12	15	16	20	22	25	27	28	28	Subslot 5
MCS.37-1	50	1180	1	DTX	0	0	2	5	7	9	12	14	16	19	22	24	27	28	28	Subslot 1
MCS.37-2	50	612	2	DTX	0	0	0	2	3	5	10	10	11	17	17	17	18	19	20	Subslot 2
MCS.37-3	50	612	3	DTX	0	0	0	2	3	5	10	10	11	17	17	17	18	19	20	Subslot 3
MCS.37-4	50	680	4	DTX	0	0	0	2	4	5	10	10	12	17	17	17	19	20	22	Subslot 4
MCS.37-5	50	1212	5	DTX	0	1	3	5	7	9	12	15	16	20	22	25	27	28	28	Subslot 5

Note 1: Mapping between Imcs and CQI Index according to Tables 7.1.7.1-1 in TS 36.213 [6].  
 Note 2: Sub-frame#0 and #5 are not used for the corresponding requirement. The next subframe (i.e. sub-frame#1 or #6) shall be used for potential retransmissions.

**Table A.4-19: Mapping of CQI Index to Modulation coding scheme (4-bit CQI Table 5)**

CQI Index			0	1	2	3	4	5	6	7	8	9	10	11	12	13	14	15	Notes	
Target Coding Rate			OOR	0.0391	0.0762	0.1172	0.1885	0.3008	0.4385	0.5879	0.3691	0.4785	0.6016	0.4551	0.5337	0.6504	0.7439	0.8525		
Modulation			QPSK				16QAM				64QAM									
MCS Scheme	PRB	Available RE-s	Imcs																	
MCS.40	1	126	DTX	0	0	0	1	4	5	8	12	14	16	18	21	23	25	27		
Note 1:			Mapping between Imcs and TBS according to Tables 7.1.7.1-1 and 7.1.7.2.1-1 in TS 36.213 [6].																	
Note 2:			startSymbolBR = 3																	

**Table A.4-20: Mapping of CQI Index to Modulation coding scheme (4-bit CQI Table 6)**

CQI Index			0	1	2	3	4	5	6	7	8	9	10	11	12	13	14	15	Notes	
Target Coding Rate			OOR	0.0547	0.2021	0.2598	0.1904	0.1387	0.2598	0.4424	0.6221	0.4131	0.5439	0.6797	0.8252	0.6357	0.7617	0.8672		
Modulation			QPSK				16QAM				64QAM									
MCS Scheme	PRB	Available RE-s	Imcs																	
MCS.41	3	378	DTX	0	2	3	2	1	3	7	9	12	15	16	16	22	25	27		
Note 1:			Mapping between Imcs and TBS according to Tables 7.1.7.1-1 and 7.1.7.2.1-1 in TS 36.213 [6].																	
Note 2:			startSymbolBR = 3																	

**Table A.4-21: Mapping of CQI Index to Modulation coding scheme (Modulation and TBS index Table 3 and 4-bit CQI Table 4)**

CQI Index			0	1	2	3	4	5	6	7	8	9	10	11	12	13	14	15	Notes	
Target Spectral Efficiency			OOR	0.1523	0.3770	0.8770	1.4766	2.4063	3.3223	3.9023	4.5234	5.1152	5.5547	6.2266	6.9141	7.4063	8.3321	9.2578		
MCS Scheme	PRB	Available RE-s	Imcs																	
MCS.38	50	6300	DTX	0	1	3	5	7	9	11	13	15	17	19	21	22	23	25		
MCS.39	100	12600	DTX	0	1	3	5	7	9	11	13	15	17	19	21	22	23	25		
Note 1:			Mapping between Imcs and CQI Index according to Tables 7.1.7.1-1B, 7.1.7.2.1-1 and 7.2.3-4 in TS 36.213 [6].																	
Note 2:			3 symbols allocated to PDCCH.																	
Note 3:			Sub-frame#0 and #5 are not used for the corresponding requirement. The next subframe (i.e. sub-frame#1 or #6) shall be used for potential retransmissions.																	



## A.5 OFDMA Channel Noise Generator (OCNG)

### A.5.1 OCNG Patterns for FDD

The following OCNG patterns are used for modelling allocations to virtual UEs (which are not under test) and/or allocations used for MBSFN. The OCNG pattern for each sub frame specifies the allocations that shall be filled with OCNG, and furthermore, the relative power level of each such allocation.

In each test case the OCNG is expressed by parameters OCNG\_RA and OCNG\_RB which together with a relative power level ( $\gamma$ ) specifies the PDSCH EPRE-to-RS EPRE ratios in OFDM symbols with and without reference symbols, respectively. The relative power, which is used for modelling boosting per virtual UE allocation, is expressed by:

$$\gamma_i = PDSCH_i\_RA / OCNG\_RA = PDSCH_i\_RB / OCNG\_RB,$$

where  $\gamma_i$  denotes the relative power level of the  $i$ :th virtual UE. The parameter settings of OCNG\_RA, OCNG\_RB, and the set of relative power levels  $\gamma$  are chosen such that when also taking allocations to the UE under test into account, as given by a PDSCH reference channel, a constant transmitted power spectral density that is constant on an OFDM symbol basis is targeted.

Moreover the OCNG pattern is accompanied by a PCFICH/PDCCH/PHICH reference channel which specifies the control region. For any aggregation and PHICH allocation, the PDCCH and any unused PHICH groups are padded with resource element groups with a power level given respectively by PDCCH\_RA/RB and PHICH\_RA/RB as specified in the test case such that a total power spectral density in the control region that is constant on an OFDM symbol basis is targeted.

For the performance requirements of UE with the CA capability, the OCNG patterns apply for each CC.

#### A.5.1.1 OCNG FDD pattern 1: One sided dynamic OCNG FDD pattern

This OCNG Pattern fills with OCNG all empty PRB-s (PRB-s with no allocation of data or system information) of the DL sub-frames, when the unallocated area is continuous in frequency domain (one sided).

**Table A.5.1.1-1: OP.1 FDD: One sided dynamic OCNG FDD Pattern**

Relative power level $\gamma_{PRB}$ [dB]			PDSCH Data
Subframe			
0	5	1 – 4, 6 – 9	
Allocation			
First unallocated PRB – Last unallocated PRB	First unallocated PRB – Last unallocated PRB	First unallocated PRB – Last unallocated PRB	
0	0	0	Note 1
Note 1: These physical resource blocks are assigned to an arbitrary number of virtual UEs with one PDSCH per virtual UE; the data transmitted over the OCNG PDSCHs shall be uncorrelated pseudo random data, which is QPSK modulated. The parameter $\gamma_{PRB}$ is used to scale the power of PDSCH.			
Note 2: If two or more transmit antennas with CRS are used in the test, the OCNG shall be transmitted to the virtual users by all the transmit antennas with CRS according to transmission mode 2. The parameter $\gamma_{PRB}$ applies to each antenna port separately, so the transmit power is equal between all the transmit antennas with CRS used in the test. The antenna transmission modes are specified in section 7.1 in 3GPP TS 36.213.			

### A.5.1.2 OCNG FDD pattern 2: Two sided dynamic OCNG FDD pattern

This OCNG Pattern fills with OCNG all empty PRB-s (PRB-s with no allocation of data or system information) of the DL sub-frames, when the unallocated area is discontinuous in frequency domain (divided in two parts by the allocated area – two sided), starts with PRB 0 and ends with PRB  $N_{RB} - 1$ .

**Table A.5.1.2-1: OP.2 FDD: Two sided dynamic OCNG FDD Pattern**

Relative power level $\gamma_{PRB}$ [dB]			PDSCH Data
Subframe			
0	5	1 – 4, 6 – 9	
Allocation			
0 – (First allocated PRB-1) and (Last allocated PRB+1) – ( $N_{RB} - 1$ )	0 – (First allocated PRB-1) and (Last allocated PRB+1) – ( $N_{RB} - 1$ )	0 – (First allocated PRB-1) and (Last allocated PRB+1) – ( $N_{RB} - 1$ )	
0	0	0	Note 1
<p>Note 1: These physical resource blocks are assigned to an arbitrary number of virtual UEs with one PDSCH per virtual UE; the data transmitted over the OCNG PDSCHs shall be uncorrelated pseudo random data, which is QPSK modulated. The parameter <math>\gamma_{PRB}</math> is used to scale the power of PDSCH.</p> <p>Note 2: If two or more transmit antennas with CRS are used in the test, the OCNG shall be transmitted to the virtual users by all the transmit antennas with CRS according to transmission mode 2. The parameter <math>\gamma_{PRB}</math> applies to each antenna port separately, so the transmit power is equal between all the transmit antennas with CRS used in the test. The antenna transmission modes are specified in section 7.1 in 3GPP TS 36.213.</p>			

### A.5.1.3 OCNG FDD pattern 3: 49 RB OCNG allocation with MBSFN in 10 MHz

**Table A.5.1.3-1: OP.3 FDD: OCNG FDD Pattern 3**

Allocation $n_{PRB}$	Relative power level $\gamma_{PRB}$ [dB]				PDSCH Data	PMCH Data
	Subframe					
	0	5	4, 9	1 – 3, 6 – 8		
1 – 49	0	0 (Allocation: all empty PRB-s)	0	N/A	Note 1	N/A
0 – 49	N/A	N/A	N/A	0	N/A	Note 2
<p>Note 1: These physical resource blocks are assigned to an arbitrary number of virtual UEs with one PDSCH per virtual UE; the data transmitted over the OCNG PDSCHs shall be uncorrelated pseudo random data, which is QPSK modulated. The parameter <math>\gamma_{PRB}</math> is used to scale the power of PDSCH.</p> <p>Note 2: Each physical resource block (PRB) is assigned to MBSFN transmission. The data in each PRB shall be uncorrelated with data in other PRBs over the period of any measurement. The MBSFN data shall be QPSK modulated. PMCH subframes shall contain cell-specific Reference Signals only in the first symbol of the first time slot. The parameter <math>\gamma_{PRB}</math> is used to scale the power of PMCH.</p> <p>Note 3: If two or more transmit antennas are used in the test, the OCNG shall be transmitted to the virtual users by all the transmit antennas according to transmission mode 2. The transmit power shall be equally split between all the transmit antennas used in the test. The antenna transmission modes are specified in section 7.1 in 3GPP TS 36.213.</p> <p>N/A: Not Applicable</p>						

### A.5.1.3A OCNG FDD pattern 3A: 49 RB OCNG allocation with MBSFN enhancement in 10 MHz

**Table A.5.1.3A-1: OP.3A FDD: OCNG FDD Pattern 3A**

Allocation $n_{PRB}$	Relative power level $\gamma_{PRB}$ [dB]			PDSCH Data	PMCH Data
	Subframe				
	0	5	1 – 4, 6 – 9		
1 – 49	0	0 (Allocation: all empty PRB-s)	N/A	Note 1	N/A
0 – 49	N/A	N/A	0	N/A	Note 2
<p>Note 1: These physical resource blocks are assigned to an arbitrary number of virtual UEs with one PDSCH per virtual UE; the data transmitted over the OCNG PDSCHs shall be uncorrelated pseudo random data, which is QPSK modulated. The parameter <math>\gamma_{PRB}</math> is used to scale the power of PDSCH.</p> <p>Note 2: Each physical resource block (PRB) is assigned to MBSFN transmission. The data in each PRB shall be uncorrelated with data in other PRBs over the period of any measurement. The MBSFN data shall be QPSK modulated and transmitted using 1.25kHz numerology. PMCH subframes shall not contain any cell-specific Reference Signals. The parameter <math>\gamma_{PRB}</math> is used to scale the power of PMCH.</p> <p>Note 3: If two or more transmit antennas are used in the test, the OCNG shall be transmitted to the virtual users by all the transmit antennas according to transmission mode 2. The transmit power shall be equally split between all the transmit antennas used in the test. The antenna transmission modes are specified in section 7.1 in 3GPP TS 36.213.</p>					
N/A: Not Applicable					

### A.5.1.4 OCNG FDD pattern 4: One sided dynamic OCNG FDD pattern for MBMS transmission

This OCNG Pattern fills with OCNG all empty PRB-s (PRB-s with no allocation of data or system information) of the DL sub-frames, when the unallocated area is continuous in frequency domain (one sided) and MBMS performance is tested.

**Table A.5.1.4-1: OP.4 FDD: One sided dynamic OCNG FDD Pattern for MBMS transmission**

Allocation $n_{PRB}$	Relative power level $\gamma_{PRB}$ [dB]			PDSCH Data	PMCH Data
	Subframe				
	0, 4, 9	5	1 – 3, 6 – 8		

First unallocated PRB – Last unallocated PRB	0	0 (Allocation: all empty PRB-s)	N/A	Note 1	N/A
First unallocated PRB – Last unallocated PRB	N/A	N/A	N/A	N/A	Note 2
<p>Note 1: These physical resource blocks are assigned to an arbitrary number of virtual UEs with one PDSCH per virtual UE; the data transmitted over the OCNG PDSCHs shall be uncorrelated pseudo random data, which is QPSK modulated. The parameter <math>\gamma_{PRB}</math> is used to scale the power of PDSCH.</p> <p>Note 2: Each physical resource block (PRB) is assigned to MBSFN transmission. The data in each PRB shall be uncorrelated with data in other PRBs over the period of any measurement. The MBSFN data shall be QPSK modulated. PMCH subframes shall contain cell-specific Reference Signals only in the first symbol of the first time slot. The parameter <math>\gamma_{PRB}</math> is used to scale the power of PMCH.</p> <p>Note 3: If two or more transmit antennas are used in the test, the OCNG shall be transmitted to the virtual users by all the transmit antennas according to transmission mode 2. The transmit power shall be equally split between all the transmit antennas used in the test. The antenna transmission modes are specified in section 7.1 in 3GPP TS 36.213.</p> <p>N/A: Not Applicable</p>					

#### A.5.1.4A OCNG FDD pattern 4A: One sided dynamic OCNG FDD pattern for enhanced MBMS transmission

This OCNG Pattern fills with OCNG all empty PRB-s (PRB-s with no allocation of data or system information) of the DL sub-frames, when the unallocated area is continuous in frequency domain (one sided) and MBMS performance is tested.

**Table A.5.1.4A-1: OP.4A FDD: One sided dynamic OCNG FDD Pattern for MBMS transmission**

Allocation $n_{PRB}$	Relative power level $\gamma_{PRB}$ [dB]			PDSCH Data	PMCH Data
	Subframe				
	0	5	1 – 4, 6 – 9		

First unallocated PRB – Last unallocated PRB	0	0 (Allocation: all empty PRB-s)	N/A	Note 1	N/A
First unallocated PRB – Last unallocated PRB	N/A	N/A	N/A	N/A	Note 2
<p>Note 1: These physical resource blocks are assigned to an arbitrary number of virtual UEs with one PDSCH per virtual UE; the data transmitted over the OCNG PDSCHs shall be uncorrelated pseudo random data, which is QPSK modulated. The parameter <math>\gamma_{PRB}</math> is used to scale the power of PDSCH.</p> <p>Note 2: Each physical resource block (PRB) is assigned to MBSFN transmission. The data in each PRB shall be uncorrelated with data in other PRBs over the period of any measurement. The MBSFN data shall be QPSK modulated. PMCH subframes shall not contain any cell-specific Reference Signals. The parameter <math>\gamma_{PRB}</math> is used to scale the power of PMCH.</p> <p>Note 3: If two or more transmit antennas are used in the test, the OCNG shall be transmitted to the virtual users by all the transmit antennas according to transmission mode 2. The transmit power shall be equally split between all the transmit antennas used in the test. The antenna transmission modes are specified in section 7.1 in 3GPP TS 36.213.</p> <p>N/A: Not Applicable</p>					

#### A.5.1.5 OCNG FDD pattern 5: One sided dynamic 16QAM modulated OCNG FDD pattern

This OCNG Pattern fills with OCNG all empty PRB-s (PRB-s with no allocation of data or system information) of DL sub-frames, when the unallocated area is continuous in the frequency domain (one sided).

**Table A.5.1.5-1: OP.5 FDD: One sided dynamic 16QAM modulated OCNG FDD Pattern**

Relative power level $\gamma_{PRB}$ [dB]			PDSCH Data
Subframe			
0	5	1 – 4, 6 – 9	
Allocation			
First unallocated PRB – Last unallocated PRB	First unallocated PRB – Last unallocated PRB	First unallocated PRB – Last unallocated PRB	
0	0	0	Note 1
<p>Note 1: These physical resource blocks are assigned to an arbitrary number of virtual UEs with one PDSCH per virtual UE; the data transmitted over the OCNG PDSCHs shall be uncorrelated pseudo random data, which is 16QAM modulated. The parameter <math>\gamma_{PRB}</math> is used to scale the power of PDSCH.</p> <p>Note 2: If two or more transmit antennas with CRS are used in the test, the OCNG shall be transmitted to the virtual users by all the transmit antennas with CRS according to transmission mode 3 (Large Delay CDD). The parameter <math>\gamma_{PRB}</math> applies to each antenna port separately, so the transmit power is equal between all the transmit antennas with CRS used in the test. The antenna transmission modes are specified in section 7.1 in 3GPP TS 36.213.</p>			

### A.5.1.6 OCNG FDD pattern 6: dynamic OCNG FDD pattern when user data is in 2 non-contiguous blocks

This OCNG Pattern fills with OCNG all empty PRB-s (PRB-s with no allocation of data or system information) of the DL sub-frames, when the unallocated area is discontinuous in frequency domain (divided in two parts by the first allocated block). The second allocated block ends with PRB  $N_{RB} - 1$ .

**Table A.5.1.6-1: OP.6 FDD: OCNG FDD Pattern when user data is in 2 non-contiguous blocks**

Relative power level $\gamma_{PRB}$ [dB]			PDSCH Data
Subframe			
0	5	1 – 4, 6 – 9	
Allocation			
0 – (First allocated PRB of first block -1) and (Last allocated PRB of first block +1) – (First allocated PRB of second block -1)	0 – (First allocated PRB of first block -1) and (Last allocated PRB of first block +1) – (First allocated PRB of second block -1)	0 – (First allocated PRB of first block -1) and (Last allocated PRB of first block +1) – (First allocated PRB of second block -1)	
0	0	0	Note 1
<p>Note 1: These physical resource blocks are assigned to an arbitrary number of virtual UEs with one PDSCH per virtual UE; the data transmitted over the OCNG PDSCHs shall be uncorrelated pseudo random data, which is QPSK modulated. The parameter <math>\gamma_{PRB}</math> is used to scale the power of PDSCH.</p> <p>Note 2: If two or more transmit antennas with CRS are used in the test, the OCNG shall be transmitted to the virtual users by all the transmit antennas with CRS according to transmission mode 2. The parameter <math>\gamma_{PRB}</math> applies to each antenna port separately, so the transmit power is equal between all the transmit antennas with CRS used in the test. The antenna transmission modes are specified in section 7.1 in 3GPP TS 36.213.</p>			

### A.5.1.7 OCNG FDD pattern 7: dynamic OCNG FDD pattern when user data is in multiple non-contiguous blocks

This OCNG Pattern fills with OCNG all empty PRB-s (PRB-s with no allocation of data, EPDCCH or system information) of the DL sub-frames, when the unallocated area is discontinuous in frequency domain (divided in multiple parts by the  $M$  allocated blocks for data transmission). The  $m$ -th allocated block starts with RPB  $N_{Start,m}$  and ends with PRB  $N_{End,m} - 1$ , where  $m = 1, \dots, M$ . The system bandwidth starts with RPB 0 and ends with  $N_{RB} - 1$ .

**Table A.5.1.7-1: OP.7 FDD: OCNG FDD Pattern when user data is in multiple non-contiguous blocks**

Relative power level $\gamma_{PRB}$ [dB]			PDSCH Data
Subframe			
0	5	1 – 4, 6 – 9	
Allocation			
0 – (PRB $N_{Start,1} - 1$ ) ... (PRB $N_{End,(m-1)} - (PRB N_{Start,m} - 1)$ ) ... (PRB $N_{End,M} - (PRB N_{RB} - 1)$ )	0 – (PRB $N_{Start,1} - 1$ ) ... (PRB $N_{End,(m-1)} - (PRB N_{Start,m} - 1)$ ) ... (PRB $N_{End,M} - (PRB N_{RB} - 1)$ )	0 – (PRB $N_{Start,1} - 1$ ) ... (PRB $N_{End,(m-1)} - (PRB N_{Start,m} - 1)$ ) ... (PRB $N_{End,M} - (PRB N_{RB} - 1)$ )	
0	0	0	Note 1
<p>Note 1: These physical resource blocks are assigned to an arbitrary number of virtual UEs with one PDSCH per virtual UE; the data transmitted over the OCNG PDSCHs shall be uncorrelated pseudo random data, which is QPSK modulated. The parameter <math>\gamma_{PRB}</math> is used to scale the power of PDSCH.</p> <p>Note 2: If two or more transmit antennas with CRS are used in the test, the OCNG shall be transmitted to the virtual users by all the transmit antennas with CRS according to transmission mode 2. The parameter <math>\gamma_{PRB}</math> applies to each antenna port separately, so the transmit power is equal between all the transmit antennas with CRS used in the test. The antenna transmission modes are specified in section 7.1 in 3GPP TS 36.213.</p>			

**A.5.1.8 OCNG FDD pattern 8: Dynamic OCNG FDD pattern for TM10 transmission**

This OCNG Pattern fills with OCNG all empty PRB-s (PRB-s with no allocation of data or system information) of the DL sub-frames, when the unallocated area is discontinuous in frequency domain where there are  $M$  unallocated PRB blocks labeled from 1-st block to  $M$ -th block ( $M > 1$ ) and the  $m$ -th block starts with PRB  $N_{Start,m}$  and end with PRB  $N_{End,m}$ , or when the unallocated area is continuous in frequency domain where  $M = 1$  (one sided). The system bandwidth starts with RPB 0 and ends with  $N_{RB} - 1$ .  $N_{End,M}$  should be equal to or less than  $N_{RB} - 1$ .

Table A.5.1.8-1: OP.8 FDD: Dynamic OCNG FDD Pattern

Relative power level $\gamma_{PRB}$ [dB]			PDSCH Data
Subframe			
0	5	1 – 4, 6 – 9	
Allocation			
1-st unallocated PRB (PRB $N_{Start,1} \sim PRB N_{End,1}$ ) ...	1-st unallocated PRB (PRB $N_{Start,1} \sim PRB N_{End,1}$ ) ...	1-st unallocated PRB (PRB $N_{Start,1} \sim PRB N_{End,1}$ ) ...	
$m$ -th unallocated PRB (PRB $N_{Start,m} \sim PRB N_{End,m}$ ) ...	$m$ -th unallocated PRB (PRB $N_{Start,m} \sim PRB N_{End,m}$ ) ...	$m$ -th unallocated PRB (PRB $N_{Start,m} \sim PRB N_{End,m}$ ) ...	
$M$ -th unallocated PRB (PRB $N_{Start,M} \sim PRB N_{End,M}$ )	$M$ -th unallocated PRB (PRB $N_{Start,M} \sim PRB N_{End,M}$ )	$M$ -th unallocated PRB (PRB $N_{Start,M} \sim PRB N_{End,M}$ )	
0	0	0	Note 1,2,3
<p>Note 1: These physical resource blocks are assigned to an arbitrary number of virtual UEs with one PDSCH per virtual UE; the data transmitted over the OCNG PDSCHs shall be uncorrelated pseudo random data, which is 16QAM modulated. The parameter <math>\gamma_{PRB}</math> is used to scale the power of PDSCH.</p> <p>Note 2: The OCNG shall be transmitted to the virtual users by all the transmit antennas according to transmission mode 10. The transmit power is equal between all the transmit antennas used in the test. The antenna transmission modes are specified in section 7.1 in 3GPP TS 36.213.</p> <p>Note 3: The detailed test set-up for TM10 transmission i.e PMI configuration is specified to each test case.</p>			

## A.5.2 OCNG Patterns for TDD

The following OCNG patterns are used for modelling allocations to virtual UEs (which are not under test). The OCNG pattern for each sub frame specifies the allocations that shall be filled with OCNG, and furthermore, the relative power level of each such allocation.

In each test case the OCNG is expressed by parameters OCNG\_RA and OCNG\_RB which together with a relative power level ( $\gamma$ ) specifies the PDSCH EPRE-to-RS EPRE ratios in OFDM symbols with and without reference symbols, respectively. The relative power, which is used for modelling boosting per virtual UE allocation, is expressed by:

$$\gamma_i = PDSCH_{i\_RA} / OCNG\_RA = PDSCH_{i\_RB} / OCNG\_RB,$$

where  $\gamma_i$  denotes the relative power level of the  $i$ :th virtual UE. The parameter settings of OCNG\_RA, OCNG\_RB, and the set of relative power levels  $\gamma$  are chosen such that when also taking allocations to the UE under test into account, as given by a PDSCH reference channel, a transmitted power spectral density that is constant on an OFDM symbol basis is targeted.

Moreover the OCNG pattern is accompanied by a PCFICH/PDCCH/PHICH reference channel which specifies the control region. For any aggregation and PHICH allocation, the PDCCH and any unused PHICH groups are padded with resource element groups with a power level given respectively by PDCCH\_RA/RB and PHICH\_RA/RB as specified in the test case such that a total power spectral density in the control region that is constant on an OFDM symbol basis is targeted.

### A.5.2.1 OCNG TDD pattern 1: One sided dynamic OCNG TDD pattern

This OCNG Pattern fills with OCNG all empty PRB-s (PRB-s with no allocation of data or system information) of the subframes available for DL transmission (depending on TDD UL/DL configuration), when the unallocated area is continuous in frequency domain (one sided).



Table A.5.2.1-1: OP.1 TDD: One sided dynamic OCNG TDD Pattern

Relative power level $\gamma_{PRB}$ [dB]				PDSCH Data
Subframe (only if available for DL)				
0	5	3, 4, 7, 8, 9 and 6 (as normal subframe) <sup>Note 2</sup>	1 and 6 (as special subframe) <sup>Note 2</sup>	
Allocation				
First unallocated PRB –	First unallocated PRB –	First unallocated PRB –	First unallocated PRB –	Note 1
Last unallocated PRB	Last unallocated PRB	Last unallocated PRB	Last unallocated PRB	
0	0	0	0	
<p>Note 1: These physical resource blocks are assigned to an arbitrary number of virtual UEs with one PDSCH per virtual UE; the data transmitted over the OCNG PDSCHs shall be uncorrelated pseudo random data, which is QPSK modulated. The parameter <math>\gamma_{PRB}</math> is used to scale the power of PDSCH.</p> <p>Note 2: Subframes available for DL transmission depends on the Uplink-Downlink configuration in Table 4.2-2 in 3GPP TS 36.211</p> <p>Note 3: If two or more transmit antennas with CRS are used in the test, the OCNG shall be transmitted to the virtual users by all the transmit antennas with CRS according to transmission mode 2. The parameter <math>\gamma_{PRB}</math> applies to each antenna port separately, so the transmit power is equal between all the transmit antennas with CRS used in the test. The antenna transmission modes are specified in section 7.1 in 3GPP TS 36.213.</p>				

### A.5.2.2 OCNG TDD pattern 2: Two sided dynamic OCNG TDD pattern

This OCNG Pattern fills with OCNG all empty PRB-s (PRB-s with no allocation of data or system information) of the subframes available for DL transmission (depending on TDD UL/DL configuration), when the unallocated area is discontinuous in frequency domain (divided in two parts by the allocated area – two sided), starts with PRB 0 and ends with PRB  $N_{RB} - 1$ .

Table A.5.2.2-1: OP.2 TDD: Two sided dynamic OCNG TDD Pattern

Relative power level $\gamma_{PRB}$ [dB]				PDSCH Data
Subframe (only if available for DL)				
0	5	3, 4, 6, 7, 8, 9 (6 as normal subframe) <sup>Note 2</sup>	1,6 (6 as special subframe) <sup>Note 2</sup>	
Allocation				
0 – (First allocated PRB-1) and (Last allocated PRB+1) – $(N_{RB} - 1)$	0 – (First allocated PRB-1) and (Last allocated PRB+1) – $(N_{RB} - 1)$	0 – (First allocated PRB-1) and (Last allocated PRB+1) – $(N_{RB} - 1)$	0 – (First allocated PRB-1) and (Last allocated PRB+1) – $(N_{RB} - 1)$	Note 1
0	0	0	0	
<p>Note 1: These physical resource blocks are assigned to an arbitrary number of virtual UEs with one PDSCH per virtual UE; the data transmitted over the OCNG PDSCHs shall be uncorrelated pseudo random data, which is QPSK modulated. The parameter <math>\gamma_{PRB}</math> is used to scale the power of PDSCH.</p> <p>Note 2: Subframes available for DL transmission depends on the Uplink-Downlink configuration in Table 4.2-2 in 3GPP TS 36.211</p> <p>Note 3: If two or more transmit antennas with CRS are used in the test, the OCNG shall be transmitted to the virtual users by all the transmit antennas with CRS according to transmission mode 2. The parameter <math>\gamma_{PRB}</math> applies to each antenna port separately, so the transmit power is equal between all the transmit antennas with CRS used in the test. The antenna transmission modes are specified in section 7.1 in 3GPP TS 36.213.</p>				

### A.5.2.3 OCNG TDD pattern 3: 49 RB OCNG allocation with MBSFN in 10 MHz

**Table A.5.2.3-1: OP.3 TDD: OCNG TDD Pattern 3 for 5ms downlink-to-uplink switch-point periodicity**

Allocation $n_{PRB}$	Relative power level $\gamma_{PRB}$ [dB]				PDSCH Data	PMCH Data
	Subframe					
	0	5	4, 9 <sup>Note 2</sup>	1, 6		
1 – 49	0	0 (Allocation: all empty PRB-s)	N/A	0	Note 1	N/A
0 – 49	N/A	N/A	0	N/A	N/A	Note 3
<p>Note 1: These physical resource blocks are assigned to an arbitrary number of virtual UEs with one PDSCH per virtual UE; the data transmitted over the OCNG PDSCHs shall be uncorrelated pseudo random data, which is QPSK modulated. The parameter <math>\gamma_{PRB}</math> is used to scale the power of PDSCH.</p> <p>Note 2: Subframes available for DL transmission depends on the Uplink-Downlink configuration in Table 4.2-2 in 3GPP TS 36.211.</p> <p>Note 3: Each physical resource block (PRB) is assigned to MBSFN transmission. The data in each PRB shall be uncorrelated with data in other PRBs over the period of any measurement. The MBSFN data shall be QPSK modulated. PMCH symbols shall not contain cell-specific Reference Signals.</p> <p>Note 4: If two or more transmit antennas are used in the test, the OCNG shall be transmitted to the virtual users by all the transmit antennas according to transmission mode 2. The transmit power shall be equally split between all the transmit antennas used in the test. The antenna transmission modes are specified in section 7.1 in 3GPP TS 36.213.</p>						
N/A	Not Applicable					

### A.5.2.4 OCNG TDD pattern 4: One sided dynamic OCNG TDD pattern for MBMS transmission

This OCNG Pattern fills with OCNG all empty PRB-s (PRB-s with no allocation of data or system information) of the DL sub-frames, when the unallocated area is continuous in frequency domain (one sided) and MBMS performance is tested.

**Table A.5.2.4-1: OP.4 TDD: One sided dynamic OCNG TDD Pattern for MBMS transmission**

Allocation $n_{PRB}$	Relative power level $\gamma_{PRB}$ [dB]				PDSCH Data	PMCH Data
	Subframe (only for DL)					
	0 and 6 (as normal subframe)	1 (as special subframe)	5	3, 4, 7 – 9		

First unallocated PRB – Last unallocated PRB	0	0 (Allocation: all empty PRB-s of DwPTS)	0 (Allocation: all empty PRB-s)	N/A	Note 1	N/A
First unallocated PRB – Last unallocated PRB	N/A	N/A	N/A	N/A	N/A	Note2
Note 1:	These physical resource blocks are assigned to an arbitrary number of virtual UEs with one PDSCH per virtual UE; the data transmitted over the OCNG PDSCHs shall be uncorrelated pseudo random data, which is QPSK modulated. The parameter $\gamma_{PRB}$ is used to scale the power of PDSCH.					
Note 2:	Each physical resource block (PRB) is assigned to MBSFN transmission. The data in each PRB shall be uncorrelated with data in other PRBs over the period of any measurement. The MBSFN data shall be QPSK modulated. PMCH symbols shall not contain cell-specific Reference Signals.					
Note 3:	If two or more transmit antennas are used in the test, the OCNG shall be transmitted to the virtual users by all the transmit antennas according to transmission mode 2. The transmit power shall be equally split between all the transmit antennas used in the test. The antenna transmission modes are specified in section 7.1 in 3GPP TS 36.213.					
N/A	Not Applicable					

### A.5.2.5 OCNG TDD pattern 5: One sided dynamic 16QAM modulated OCNG TDD pattern

This OCNG Pattern fills with OCNG all empty PRB-s (PRB-s with no allocation of data or system information) of the sub-frames available for DL transmission (depending on TDD UL/DL configuration), when the unallocated area is continuous in frequency domain (one sided).

**Table A.5.2.5-1: OP.5 TDD: One sided dynamic 16QAM modulated OCNG TDD Pattern**

Relative power level $\gamma_{PRB}$ [dB]				PDSCH Data
Subframe (only if available for DL)				
0	5	3, 4, 7, 8, 9 and 6 (as normal subframe) <small>Note 2</small>	1 and 6 (as special subframe) <small>Note 2</small>	
Allocation				
First unallocated PRB –	First unallocated PRB –	First unallocated PRB –	First unallocated PRB –	Note 1
Last unallocated PRB	Last unallocated PRB	Last unallocated PRB	Last unallocated PRB	
0	0	0	0	
<p>Note 1: These physical resource blocks are assigned to an arbitrary number of virtual UEs with one PDSCH per virtual UE; the data transmitted over the OCNG PDSCHs shall be uncorrelated pseudo random data, which is 16QAM modulated. The parameter <math>\gamma_{PRB}</math> is used to scale the power of PDSCH.</p> <p>Note 2: Subframes available for DL transmission depends on the Uplink-Downlink configuration in Table 4.2-2 in 3GPP TS 36.211</p> <p>Note 3: If two or more transmit antennas with CRS are used in the test, the OCNG shall be transmitted to the virtual users by all the transmit antennas with CRS according to transmission mode 3 (Large Delay CDD). The parameter <math>\gamma_{PRB}</math> applies to each antenna port separately, so the transmit power is equal between all the transmit antennas with CRS used in the test. The antenna transmission modes are specified in section 7.1 in 3GPP TS 36.213.</p>				

**A.5.2.6 OCNG TDD pattern 6: dynamic OCNG TDD pattern when user data is in 2 non-contiguous blocks**

This OCNG Pattern fills with OCNG all empty PRB-s (PRB-s with no allocation of data or system information) of the subframes available for DL transmission (depending on TDD UL/DL configuration), when the unallocated area is discontinuous in frequency domain (divided in two parts by the first allocated block). The second allocated block ends with PRB  $N_{RB} - 1$ .

**Table A.5.2.6-1: OP.6 TDD: OCNG TDD Pattern when user data is in 2 non-contiguous blocks**

Relative power level $\gamma_{PRB}$ [dB]				PDSCH Data
Subframe (only if available for DL)				
0	5	3, 4, 6, 7, 8, 9 (6 as normal subframe) <small>Note 2</small>	1,6 (6 as special subframe) <small>Note 2</small>	
Allocation				Note 1
0 – (First allocated PRB of first block -1) and (Last allocated PRB of first block +1) – (First allocated PRB of second block -1)	0 – (First allocated PRB of first block -1) and (Last allocated PRB of first block +1) – (First allocated PRB of second block -1)	0 – (First allocated PRB of first block -1) and (Last allocated PRB of first block +1) – (First allocated PRB of second block -1)	0 – (First allocated PRB of first block -1) and (Last allocated PRB of first block +1) – (First allocated PRB of second block -1)	
0	0	0	0	
<p>Note 1: These physical resource blocks are assigned to an arbitrary number of virtual UEs with one PDSCH per virtual UE; the data transmitted over the OCNG PDSCHs shall be uncorrelated pseudo random data, which is QPSK modulated. The parameter <math>\gamma_{PRB}</math> is used to scale the power of PDSCH.</p> <p>Note 2: Subframes available for DL transmission depends on the Uplink-Downlink configuration in Table 4.2-2 in 3GPP TS 36.211</p> <p>Note 3: If two or more transmit antennas with CRS are used in the test, the OCNG shall be transmitted to the virtual users by all the transmit antennas with CRS according to transmission mode 2. The parameter <math>\gamma_{PRB}</math> applies to each antenna port separately, so the transmit power is equal between all the transmit antennas with CRS used in the test. The antenna transmission modes are specified in section 7.1 in 3GPP TS 36.213.</p>				

### A.5.2.7 OCNG TDD pattern 7: dynamic OCNG TDD pattern when user data is in multiple non-contiguous blocks

This OCNG Pattern fills with OCNG all empty PRB-s (PRB-s with no allocation of data, EPDCCH or system information) of the DL sub-frames, when the unallocated area is discontinuous in frequency domain (divided in multiple parts by the  $M$  allocated blocks for data transmission). The  $m$ -th allocated block starts with RPB  $N_{Start,m}$  and ends with PRB  $N_{End,m} - 1$ , where  $m = 1, \dots, M$ . The system bandwidth starts with RPB 0 and ends with  $N_{RB} - 1$ .

**Table A.5.2.7-1: OP.7 TDD: OCNG TDD Pattern when user data is in multiple non-contiguous blocks**

Relative power level $\gamma_{PRB}$ [dB]				PDSCH Data
Subframe (only if available for DL)				
0	5	3, 4, 6, 7, 8, 9 (6 as normal subframe) <small>Note 2</small>	1,6 (6 as special subframe) <small>Note 2</small>	
Allocation				
$0 - (\text{PRB } N_{Start,1} - 1)$	$0 - (\text{PRB } N_{Start,1} - 1)$	$0 - (\text{PRB } N_{Start,1} - 1)$	$0 - (\text{PRB } N_{Start,1} - 1)$	
...	...	...	...	
$(\text{PRB } N_{End,(m-1)} - (\text{PRB } N_{Start,m} - 1))$	$(\text{PRB } N_{End,(m-1)} - (\text{PRB } N_{Start,m} - 1))$	$(\text{PRB } N_{End,(m-1)} - (\text{PRB } N_{Start,m} - 1))$	$(\text{PRB } N_{End,(m-1)} - (\text{PRB } N_{Start,m} - 1))$	
...	...	...	...	
$(\text{PRB } N_{End,M} - (\text{PRB } N_{RB} - 1))$	$(\text{PRB } N_{End,M} - (\text{PRB } N_{RB} - 1))$	$(\text{PRB } N_{End,M} - (\text{PRB } N_{RB} - 1))$	$(\text{PRB } N_{End,M} - (\text{PRB } N_{RB} - 1))$	
0	0	0	0	Note 1
<p>Note 1: These physical resource blocks are assigned to an arbitrary number of virtual UEs with one PDSCH per virtual UE; the data transmitted over the OCNG PDSCHs shall be uncorrelated pseudo random data, which is QPSK modulated. The parameter <math>\gamma_{PRB}</math> is used to scale the power of PDSCH.</p> <p>Note 2: Subframes available for DL transmission depends on the Uplink-Downlink configuration in Table 4.2-2 in 3GPP TS 36.211</p> <p>Note 3: If two or more transmit antennas with CRS are used in the test, the OCNG shall be transmitted to the virtual users by all the transmit antennas with CRS according to transmission mode 2. The parameter <math>\gamma_{PRB}</math> applies to each antenna port separately, so the transmit power is equal between all the transmit antennas with CRS used in the test. The antenna transmission modes are specified in section 7.1 in 3GPP TS 36.213.</p>				

### A.5.2.8 OCNG TDD pattern 8: Dynamic OCNG TDD pattern for TM10 transmission

This OCNG Pattern fills with OCNG all empty PRB-s (PRB-s with no allocation of data or system information) of the DL sub-frames, when the unallocated area is discontinuous in frequency domain where there are  $M$  unallocated PRB blocks labled from 1-st block to  $M$ -th block ( $M > 1$ ) and the  $m$ -th block starts with PRB  $N_{Start,m}$  and end with PRB  $N_{End,m}$ , or when the unallocated area is continuous in frequency domain where  $M = 1$  (one sided). The system bandwidth starts with RPB 0 and ends with  $N_{RB} - 1$ .  $N_{End,M}$  should be equal to or less than  $N_{RB} - 1$ .

**Table A.5.2.8-1: OP.8 TDD: Dynamic OCNG TDD Pattern**

Relative power level $\gamma_{PRB}$ [dB]			PDSCH Data
Subframe			
0	5	1 – 4, 6 – 9	
Allocation			
1-st unallocated PRB (PRB $N_{Start,1} \sim PRB N_{End,1}$ ) ...	1-st unallocated PRB (PRB $N_{Start,1} \sim PRB N_{End,1}$ ) ...	1-st unallocated PRB (PRB $N_{Start,1} \sim PRB N_{End,1}$ ) ...	
$m$ -th unallocated PRB (PRB $N_{Start,m} \sim PRB N_{End,m}$ ) ...	$m$ -th unallocated PRB (PRB $N_{Start,m} \sim PRB N_{End,m}$ ) ...	$m$ -th unallocated PRB (PRB $N_{Start,m} \sim PRB N_{End,m}$ ) ...	
$M$ -th unallocated PRB (PRB $N_{Start,M} \sim PRB N_{End,M}$ )	$M$ -th unallocated PRB (PRB $N_{Start,M} \sim PRB N_{End,M}$ )	$M$ -th unallocated PRB (PRB $N_{Start,M} \sim PRB N_{End,M}$ )	
0	0	0	Note 1,2,3
<p>Note 1: These physical resource blocks are assigned to an arbitrary number of virtual UEs with one PDSCH per virtual UE; the data transmitted over the OCNG PDSCHs shall be uncorrelated pseudo random data, which is 16QAM modulated. The parameter <math>\gamma_{PRB}</math> is used to scale the power of PDSCH.</p> <p>Note 2: The OCNG shall be transmitted to the virtual users by all the transmit antennas according to transmission mode 10. The transmit power is equal between all the transmit antennas used in the test. The antenna transmission modes are specified in section 7.1 in 3GPP TS 36.213.</p> <p>Note 3: The detailed test set-up for TM10 transmission i.e PMI configuration is specified to each test case.</p>			

### A.5.3 OCNG Patterns for Narrowband IoT

The following OCNG patterns are used for modelling allocations to virtual narrowband IoT UEs (which are not under test). The OCNG pattern for each sub frame specifies the allocations that shall be filled with OCNG, and furthermore, the relative power level of each such allocation.

In each test case the OCNG is expressed by parameters OCNG\_RA and OCNG\_RB which together with a relative power level ( $\gamma$ ) specifies the NPDSCH EPRE-to-NRS EPRE ratios in OFDM symbols with and without Narrowband reference symbols, respectively. The relative power, which is used for modelling boosting per virtual UE allocation, is expressed by:

$$\gamma_i = NPDSCH_{i\_RA} / OCNG\_RA = NPDSCH_{i\_RB} / OCNG\_RB,$$

where  $\gamma_i$  denotes the relative power level of the  $i$ :th virtual UE. The parameter settings of OCNG\_RA, OCNG\_RB, and the set of relative power levels  $\gamma$  are chosen such that when also taking allocations to the UE under test into account, as given by a NPDSCH or NPDCCH reference channel, a transmitted power spectral density that is constant on an OFDM symbol basis is targeted.

#### A.5.3.1 Narrowband IoT OCNG pattern 1

**Table A.5.3.1-1: NB.OP.1 FDD: OCNG FDD Pattern 1**

Bandwidth	Relative power level $\gamma$ [dB]		NPDCCH and corresponding NPDSCH Data
	Subframe		
	Unused subframes		

200KHz	0	Note 2
Note 1:	These subframes are assigned to an arbitrary number of virtual UEs with one NPDSCH per virtual UE with corresponding NPDCCH; the data transmitted over the OCNG NPDSCHs shall be uncorrelated pseudo random data, which is QPSK modulated. The parameter $\gamma$ is used to scale the power of NPDSCH and NPDCCH.	
Note 2:	Subframes and/or REs available for narrowband IOT DL transmission depend on the in-band, guard band or standalone mode indicated in MIB, and scheduling delay between NPDCCH, NPDSCH, NPUSCH format 2 and NPDCCH specified in test cases.	
Note 3:	If two or more transmit antennas with NRS are used in the test, the OCNG shall be transmitted to the virtual users by all the transmit antennas with NRS according to transmit diversity scheme. The parameter $\gamma$ applies to each antenna port separately, so the transmit power is equal between all the transmit antennas with NRS used in the test.	

### A.5.4 OCNG Patterns for frame structure type 3

The following OCNG patterns are used for modelling allocations to virtual UEs (which are not under test). The OCNG pattern for each sub frame specifies the allocations that shall be filled with OCNG, and furthermore, the relative power level of each such allocation.

In each test case the OCNG is expressed by parameters OCNG\_RA and OCNG\_RB which together with a relative power level ( $\gamma$ ) specifies the PDSCH EPRE-to-RS EPRE ratios in OFDM symbols with and without reference symbols, respectively. The relative power, which is used for modelling boosting per virtual UE allocation, is expressed by:

$$\gamma_i = PDSCH_{i\_RA} / OCNG\_RA = PDSCH_{i\_RB} / OCNG\_RB,$$

where  $\gamma_i$  denotes the relative power level of the  $i$ :th virtual UE. The parameter settings of OCNG\_RA, OCNG\_RB, and the set of relative power levels  $\gamma$  are chosen such that when also taking allocations to the UE under test into account, as given by a PDSCH reference channel, a constant transmitted power spectral density that is constant on an OFDM symbol basis is targeted.

Moreover the OCNG pattern is accompanied by a PDCCH reference channel which specifies the control region. For any aggregation the PDCCH are padded with resource element groups with a power level given respectively by PDCCH\_RA/RB as specified in the test case such that a total power spectral density in the control region that is constant on an OFDM symbol basis is targeted.

For the performance requirements of UE with the CA capability, the OCNG patterns apply for each LAA Scell.

#### A.5.4.1 OCNG FS3 pattern 1: One sided dynamic OCNG frame structure type 3 pattern

This OCNG Pattern fills with OCNG all empty PRB-s (PRB-s with no allocation of data or system information) of the DL sub-frames, when the unallocated area is continuous in frequency domain (one sided).

**Table A.5.4.1-1: OP.1 FS3: One sided dynamic OCNG frame structure type 3 Pattern**

Relative power level $\gamma_{PRB}$ [dB]			PDSCH Data
Subframe			
0	5	1 – 4, 6 – 9	
Allocation			
First unallocated PRB – Last unallocated PRB	First unallocated PRB – Last unallocated PRB	First unallocated PRB – Last unallocated PRB	
0	0	0	Note 1
<p>Note 1: These physical resource blocks are assigned to an arbitrary number of virtual UEs with one PDSCH per virtual UE; the data transmitted over the OCNG PDSCHs shall be uncorrelated pseudo random data, which is QPSK modulated. The parameter <math>\gamma_{PRB}</math> is used to scale the power of PDSCH.</p> <p>Note 2: If two or more transmit antennas with CRS are used in the test, the OCNG shall be transmitted to the virtual users by all the transmit antennas with CRS according to transmission mode 2. The parameter <math>\gamma_{PRB}</math> applies to each antenna port separately, so the transmit power is equal between all the transmit antennas with CRS used in the test. The antenna transmission modes are specified in section 7.1 in 3GPP TS 36.213.</p> <p>Note 3: Subframes available for DL transmission and Occupied OFDM symbols in each subframe depend on the downlink burst transmission pattern and its corresponding configuration</p>			

### A.5.4.2 OCNG FS3 pattern 2: Two sided dynamic OCNG frame structure 3 pattern

This OCNG Pattern fills with OCNG all empty PRB-s (PRB-s with no allocation of data or system information) of the DL sub-frames, when the unallocated area is discontinuous in frequency domain (divided in two parts by the allocated area – two sided), starts with PRB 0 and ends with PRB  $N_{RB} - 1$ .

**Table A.5.4.2-1: OP.2 FS3: Two sided dynamic OCNG frame structure type 3 Pattern**

Relative power level $\gamma_{PRB}$ [dB]			PDSCH Data
Subframe			
0	5	1 – 4, 6 – 9	
Allocation			
0 – (First allocated PRB-1) and (Last allocated PRB+1) – ( $N_{RB} - 1$ )	0 – (First allocated PRB-1) and (Last allocated PRB+1) – ( $N_{RB} - 1$ )	0 – (First allocated PRB-1) and (Last allocated PRB+1) – ( $N_{RB} - 1$ )	
0	0	0	Note 1
<p>Note 1: These physical resource blocks are assigned to an arbitrary number of virtual UEs with one PDSCH per virtual UE; the data transmitted over the OCNG PDSCHs shall be uncorrelated pseudo random data, which is QPSK modulated. The parameter <math>\gamma_{PRB}</math> is used to scale the power of PDSCH.</p> <p>Note 2: If two or more transmit antennas with CRS are used in the test, the OCNG shall be transmitted to the virtual users by all the transmit antennas with CRS according to transmission mode 2. The parameter <math>\gamma_{PRB}</math> applies to each antenna port separately, so the transmit power is equal between all the transmit antennas with CRS used in the test. The antenna transmission modes are specified in section 7.1 in 3GPP TS 36.213.</p> <p>Note 3: Subframes available for DL transmission and Occupied OFDM symbols in each subframe depend on the downlink burst transmission pattern and its corresponding configuration.</p>			



## A.6 Sidelink reference measurement channels

### A.6.1 General

The algorithm for determining the payload size  $A$  is as follows; given a desired coding rate  $R$  and radio block allocation  $N_{RB}$

1. Calculate the number of channel bits  $N_{ch}$  that can be transmitted during the first transmission of a given sub-frame.
2. Find  $A$  such that the resulting coding rate is as close to  $R$  as possible, that is,

$$\min |R - (A + 24 * (N_{CB} + 1)) / N_{ch}|, \text{ where } N_{CB} = \begin{cases} 0, & \text{if } C = 1 \\ C, & \text{if } C > 1 \end{cases},$$

subject to

- a)  $A$  is a valid TB size according to section 7.1.7 of TS 36.213 [6] assuming an allocation of  $N_{RB}$  resource blocks.
  - b)  $C$  is the number of Code Blocks calculated according to section 5.1.2 of TS 36.212 [5].
3. If there is more than one  $A$  that minimizes the equation above, then the larger value is chosen per default and the chosen code rate should not exceed 0.93.

#### A.6.1.1 Overview of ProSe reference measurement channels

In Table A.6.1.1-1 are listed the ProSe reference measurement channels specified in annexes A.6.2 to A.6.6 of this release of TS 36.101. This table is informative and serves only to a better overview. The reference for the concrete reference measurement channels and corresponding implementation's parameters as to be used for requirements are annexes A.6.2 to A.6.6 as appropriate.

Table A.6.1.1-1: Overview of ProSe reference measurement channels

Table	Name	BW	Mod	RB	UE Categ	Notes
Table A.6.2-1	-	5	QPSK	2	$\geq 1$	
Table A.6.2-1	-	10	QPSK	2	$\geq 1$	
Table A.6.2-1	-	15	QPSK	2	$\geq 1$	
Table A.6.2-1	-	20	QPSK	2	$\geq 1$	
Table A.6.2-2	-	5	QPSK	25	$\geq 1$	
Table A.6.2-2	-	10	QPSK	50	$\geq 1$	
Table A.6.2-3	-	5	16QAM	25	2-8	
Table A.6.2-3	-	10	16QAM	50	2-8	
Table A.6.2-4	-	5	16QAM	25	1	
Table A.6.2-4	-	10	16QAM	50	1	
Table A.6.3-1	D.1 FDD / D.1 TDD	5	QPSK	2	$\geq 1$	
Table A.6.3-1	D.1 FDD / D.1 TDD	10	QPSK	2	$\geq 1$	
Table A.6.3-1	D.1 FDD / D.1 TDD	15	QPSK	2	$\geq 1$	
Table A.6.3-1	D.1 FDD / D.1 TDD	20	QPSK	2	$\geq 1$	
Table A.6.4-1	CC.1 FDD	5	QPSK	1	-	
Table A.6.4-1	CC.2 FDD	10	QPSK	1	-	
Table A.6.4-1	CC.3 FDD	5	QPSK	1	-	
Table A.6.4-1	CC.4 FDD	10	QPSK	1	-	
Table A.6.4-1	CC.5 FDD	5	QPSK	1	-	
Table A.6.4-1	CC.6 FDD	10	QPSK	1	-	
Table A.6.5-1	CD.1 FDD	5/10	QPSK	10	-	
Table A.6.5-1	CD.2 FDD	5/10	16QAM	10	-	
Table A.6.5-1	CD.3 FDD	5	16QAM	25	-	
Table A.6.5-1	CD.4 FDD	10	16QAM	50	-	
Table A.6.5-1	CD.5 FDD	5/10	QPSK	2	-	
Table A.6.5-2	CD.6 FDD	5	16QAM	25	-	
Table A.6.5-2	CD.7 FDD	10	16QAM	50	-	
Table A.6.6-1	CP.1 FDD	5/10	QPSK	6	-	

## A.6.2 Reference measurement channel for receiver characteristics

For ProSe Direct Discovery, Table A.6.2-1 is applicable for measurements on the Receiver Characteristics (clause 7) including the requirements of subclause 7.4D (Maximum input level).

For ProSe Direct Communication, Table A.6.2-2 is applicable for measurements on the Receiver Characteristics (clause 7) with the exception of subclause 7.4D (Maximum input level). Tables A.6.2-3, A.6.2-4, are applicable for subclause 7.4D (Maximum input level).

**Table A.6.2-1: Fixed Reference measurement channel for ProSe Direct Discovery receiver requirements and maximum input level**

Parameter	Unit	Value					
		1.4	3	5	10	15	20
Channel bandwidth	MHz	1.4	3	5	10	15	20
Allocated resource blocks				2	2	2	2
Subcarriers per resource block				12	12	12	12
Allocated subframes per Discovery period				1	1	1	1
DFT-OFDM Symbols per subframe (see note)				11	11	11	11
Modulation				QPSK	QPSK	QPSK	QPSK
Transport Block Size				232	232	232	232
Transport block CRC	Bits			24	24	24	24
Maximum number of HARQ transmissions				1	1	1	1
Binary Channel Bits (see note)	Bits			528	528	528	528
Max. Throughput averaged over 1 Discovery period of 320ms	kbps			0.725	0.725	0.725	0.725
UE Category				≥ 1	≥ 1	≥ 1	≥ 1
NOTE1: PSDCH transmissions are rate-matched for 12 DFT-OFDM symbols per subframe, and the last symbol shall be punctured as per TS 36.211.							
NOTE2: Throughput is 232 bits per Discovery period. The discovery period is configured as 320ms in the test.							

**Table A.6.2-2: Fixed Reference measurement channel for ProSe Direct Communication receiver requirements**

Parameter	Unit	Value					
		1.4	3	5	10	15	20
Channel bandwidth	MHz	1.4	3	5	10	15	20
Allocated resource blocks				25	50		
Subcarriers per resource block				12	12		
Packets per SA period				1	1		
Modulation				QPSK	QPSK		
Transport Block Size				2216	4392		
Transport block CRC	Bits			24	24		
Maximum number of HARQ transmissions				4	4		
Binary Channel Bits	Bits			7200	14400		
Max. Throughput averaged over 1 SA period of 40ms	kbps			55.4	109.8		
UE Category				≥ 1	≥ 1		
NOTE 1: For PSSCH transmission, the last symbol shall be punctured as per TS 36.211.							
NOTE 2: Throughput (in kbps) will depend on SA period configuration							

**Table A.6.2-3: Fixed Reference measurement channel for ProSe Direct Communication for maximum input power for UE categories 2-8**

Parameter	Unit	Value					
		1.4	3	5	10	15	20
Channel bandwidth	MHz	1.4	3	5	10	15	20
Allocated resource blocks				25	50		
Subcarriers per resource block				12	12		
Packets per SA period				1	1		
Modulation				16QAM	16QAM		
Transport Block Size				9912	18336		
Transport block CRC	Bits			24	24		
Maximum number of HARQ transmissions				4	4		
Binary Channel Bits	Bits			14400	28800		
Max. Throughput averaged over 1 SA period of 40ms	kbps			247.8	458.4		
NOTE 1: For PSSCH transmission, the last symbol shall be punctured as per TS 36.211.							
NOTE 2: If more than one Code Block is present, an additional CRC sequence of L = 24 Bits is attached to each Code Block (otherwise L = 0 Bit).							
NOTE 3: Throughput (in kbps) will depend on SA period configuration							

**Table A.6.2-4: Fixed Reference measurement channel for ProSe Direct Communication for maximum input power for UE category 1**

Parameter	Unit	Value					
		1.4	3	5	10	15	20
Channel bandwidth	MHz	1.4	3	5	10	15	20
Allocated resource blocks				25	24		
Subcarriers per resource block				12	12		
Packets per SA period				1	1		
Modulation				16QAM	16QAM		
Transport Block Size				9912	10296		
Transport block CRC	Bits			24	24		
Maximum number of HARQ transmissions				4	4		
Binary Channel Bits	Bits			14400	13824		
Max. Throughput averaged over 1 SA period of 40ms	kbps			247.8	257.4		

NOTE 1: For PSSCH transmission, the last symbol shall be punctured as per TS 36.211.  
NOTE 2: If more than one Code Block is present, an additional CRC sequence of L = 24 Bits is attached to each Code Block (otherwise L = 0 Bit).  
NOTE 3: Throughput (in kbps) will depend on SA period configuration

### A.6.3 Reference measurement channels for PSDCH performance requirements

**Table A.6.3-1: Fixed Reference measurement channel for PSDCH performance requirement**

Parameter	Unit	Value					
		D.1 FDD / D.1 TDD					
Reference channel		1.4	3	5	10	15	20
Channel bandwidth	MHz	1.4	3	5	10	15	20
Allocated resource blocks				2	2	2	2
Subcarriers per resource block				12	12	12	12
DFT-OFDM Symbols per subframe (NOTE 1)				11	11	11	11
Modulation				QPSK	QPSK	QPSK	QPSK
Transport Block Size				232	232	232	232
Transport block CRC	Bits			24	24	24	24
Binary Channel Bits (NOTE 1)	Bits			528	528	528	528
Max. Throughput averaged over 1 Discovery period of 320ms	kbps			0.725	0.725	0.725	0.725
UE Category				≥ 1	≥ 1	≥ 1	≥ 1

NOTE1: PSDCH transmissions are rate-matched for 12 DFT-OFDM symbols per subframe, and the last symbol shall be punctured as per TS 36.211.

## A.6.4 Reference measurement channels for PSCCH performance requirements

**Table A.6.4-1: Fixed reference measurement channel for PSCCH performance requirement**

Parameter	Unit	Value					
		CC.1 FDD	CC.2 FDD	CC.3 FDD	CC.4 FDD	CC.5 FDD	CC.6 FDD
Reference channel							
Channel bandwidth	MHz	5	10	5	10	5	10
Allocated resource blocks		1	1	1	1	1	1
Subcarriers per resource block		12	12	12	12	12	12
DFT-OFDM Symbols per subframe (see Note 1)		11	11	11	11	11	11
Modulation		QPSK	QPSK	QPSK	QPSK	QPSK	QPSK
Transport Block Size	Bits	41	43	41	43	41	43
Information bits	Frequency hopping flag	0	0	1	1	1	1
	RB assignment	Set as per PSSCH RB allocation specific in the test					
	Hopping bits	N/A	N/A	1 Type 2 Hopping	(1,1) Type 2 Hopping	0 Type 1 Hopping	(1,0) Type 1 Hopping
	Time resource pattern ( $I_{TRP}$ )	8 (unless specified otherwise in the test) (Note 3)					
	Modulation and coding scheme	Set as the PSSCH MCS specified in the test					
	Timing advance indication	0 (unless specified otherwise in the test)					
	Group destination ID	As set by higher layers					
Transport block CRC	Bits	16	16	16	16	16	16
Maximum number of HARQ transmissions		2	2	2	2	2	2
Binary Channel Bits (see Note 1,2)	Bits	264	264	264	264	264	264
Max. Throughput averaged over one sc-period (bits/sc-period)		41	43	41	43	41	43
NOTE 1: PSCCH transmissions are rate-matched for 12 DFT-OFDM symbols per subframe, and the last symbol shall be punctured as per TS 36.211.							
NOTE 2: Binary channel bits per HARQ transmission.							
NOTE 3: For $N_{TRP} = 8$ (FDD) and $trpt-Subset = 010$ , $I_{TRP} = 8$ corresponds to a time repetition pattern of (1,1,0,0,0,0,0,0) as per TS 36.213.							

## A.6.5 Reference measurement channels for PSSCH performance requirements

**Table A.6.5-1: Fixed reference measurement channel for PSSCH performance requirement**

Parameter	Unit	Value				
		CD.1 FDD	CD.2 FDD	CD.3 FDD	CD.4 FDD	CD.5 FDD
Reference channel						
Channel bandwidth	MHz	5 / 10	5 / 10	5	10	5 / 10
Allocated resource blocks		10	10	25	50	2
Subcarriers per resource block		12	12	12	12	12
DFT-OFDM Symbols per subframe (see Note 1)		11	11	11	11	11
Modulation		QPSK	16QAM	16QAM	16QAM	QPSK
Transport Block Size		872	2536	6456	12960	328
Transport block CRC	Bits	24	24	24	24	24
Maximum number of HARQ transmissions		4	4	4	4	4
Binary Channel Bits (see Note 1,2)	Bits	2640	5280	13200	26400	528
Max. Throughput averaged over one sc-period (bits/sc-period)		872	2536	6456	12960	328
NOTE 1: PSSCH transmissions are rate-matched for 12 DFT-OFDM symbols per subframe, and the last symbol shall be punctured as per TS 36.211.						
NOTE 2: Binary channel bits per HARQ transmission.						
NOTE 3: If more than one Code Block is present, an additional CRC sequence of L = 24 Bits is attached to each Code Block (otherwise L = 0 Bit).						

**Table A.6.5-2: Fixed reference measurement channel for PSSCH for maximum Sidelink processes test**

Parameter	Unit	Value	
		CD.6 FDD	CD.7 FDD
Reference channel		CD.6 FDD	CD.7 FDD
Channel bandwidth	MHz	5	10
Allocated resource blocks		25	50
Subcarriers per resource block		12	12
DFT-OFDM Symbols per subframe (see Note 1)		11	11
Modulation		16QAM	16QAM
Transport Block Size		15840	25456
Transport block CRC	Bits	24	24
Maximum number of HARQ transmissions		4	4
Binary Channel Bits (see Note 1,2)	Bits	13200	26400
Max. Throughput averaged over one sc-period (bits/sc-period)		15840	25456
NOTE 1: PSSCH transmissions are rate-matched for 12 DFT-OFDM symbols per subframe, and the last symbol shall be punctured as per TS 36.211.			
NOTE 2: Binary channel bits per HARQ transmission.			
NOTE 3: If more than one Code Block is present, an additional CRC sequence of L = 24 Bits is attached to each Code Block (otherwise L = 0 Bit).			

## A.6.6 Reference measurement channels for PSBCH performance requirements

**Table A.6.6-1: Fixed reference measurement channel for PSBCH performance requirement**

Parameter	Unit	Value
Reference channel		CP.1 FDD
Channel bandwidth	MHz	5 / 10
Allocated resource blocks		6
Subcarriers per resource block		12
DFT-OFDM Symbols per subframe (see Note 1)		7
Modulation		QPSK
Transport Block Size		40
Transport block CRC	Bits	16
Maximum number of HARQ transmissions		1
Binary Channel Bits (see Note 1,2)	Bits	1008
Max. Throughput averaged over 40ms	kbps	1
NOTE 1: PSBCH transmissions are rate-matched for 8 DFT-OFDM symbols per subframe, and the last symbol shall be punctured as per TS 36.211.		
NOTE 2: Binary channel bits per HARQ transmission.		

## A.7 Sidelink reference resource pool configurations

### A.7.1 Reference resource pool configurations for ProSe Direct Discovery demodulation tests

#### A.7.1.1 FDD

Table A.7.1.1-1: ProSe Direct Discovery configuration for E-UTRA FDD (Configuration #1-FDD)

Information Element		Value
discRxPool	cp-Len	Normal
	discPeriod	rf32
	numRetx	0
	numRepetition	1
tf-ResourceConfig	prb-Num	12
	prb-Start	0
	prb-End	23
	offsetIndicator	160
	subframeBitmap	10000000 00000000 00000000 00000000 00000000
	txParameters	not present
	rxParameters	not present
discTxPoolCommon		not present
discTxPowerInfo		not present
SL-SyncConfig		not present
discInterFreqList		not present

Table A.7.1.1-2: ProSe Direct Discovery configuration for E-UTRA FDD (Configuration #2-FDD)

Information Element			Value
discRxPool(0)	cp-Len		Normal
	discPeriod		rf32
	numRetx		0
	numRepetition		1
	tf-ResourceConfig	prb-Num	12
		prb-Start	0
		prb-End	23
		offsetIndicator	150
		subframeBitmap	10000000 00000000 00000000 00000000 00000000
	txParameters		not present
rxParameters		not present	
discRxPool(1)	cp-Len		Normal
	discPeriod		rf32
	numRetx		0
	numRepetition		1
	tf-ResourceConfig	prb-Num	12
		prb-Start	0
		prb-End	23
		offsetIndicator	170
		subframeBitmap	10000000 00000000 00000000 00000000 00000000
	txParameters		not present
rxParameters	tdd-Config	not present	
	syncConfigIndex	0	
discTxPoolCommon		not present	
discTxPowerInfo		not present	
SL-SyncConfig(0)	syncCP-Len		Normal
	syncOffsetIndicator		0 (160 mod 40)
	sIssid		30
	txParameters		not present
	rxParamsNCell	physCellId	1
		discSyncWindow	w1
	discInterFreqList		not present



**Table A.7.1.1-3: ProSe Direct Discovery configuration for E-UTRA FDD (Configuration #3-FDD)**

Information Element			Value
discRxPool(iPool), iPool = 0...NPool-1	cp-Len		Normal
	discPeriod		rf32
	numRetx		3
	numRepetition		=2 if NPool > 10, =1 otherwise
	tf-ResourceConfig	prb-Num	5MHz: $\min\{24, 2N-24*iPool\} / 2$ 10MHz: 25 15MHz: $\min\{74, 2N-74*iPool\} / 2$ 20MHz: 50
		prb-Start	0
		prb-End	5 MHz: $\min\{24, 2N-24*iPool\} - 1$ 10 MHz: 49 15 MHz: $\min\{74, 2N-74*iPool\} - 1$ 20 MHz: 99
		offsetIndicator	160
		subframeBitmap	a(0), a(1), ..., a(39), s.t.  a(i * NPool + iPool) = 1, i = 0,...,K; a(k) = 0 otherwise  where K = 1 is NPool > 10, K = 3 otherwise
	txParameters		not present
	rxParameters		not present
discTxPoolCommon			not present
discTxPowerInfo			not present
SL-SyncConfig			not present
discInterFreqList			not present
NOTE 1: The resource pool configuration description is parameterized using channel BW, number of configured resource pools (NPool), and maximum number of configured Sidelink UEs to be supported (N).			

**Table A.7.1.1-4: ProSe Direct Discovery configuration for E-UTRA FDD for out-of-network coverage operation (Configuration #4-FDD)**

Information Element			Value		
			5MHz	10MHz	
preconfigSync	syncCP-Len-r12		Normal		
	syncOffsetIndicator1		1		
	syncOffsetIndicator2		2		
	syncTxParameters		23		
	syncTxThreshOoC		0 (-110dBm / 15kHz)		
	filterCoefficient		fc0		
	syncRefMinHyst		dB0		
	syncRefDiffHyst		dB0		
	syncTxPeriodic		TRUE		
preconfigDisc	discRxPoolList(0)	cp-Len	Normal		
		discPeriod	rf4		
		numRetx	0		
		numRepetition	1		
		tf-ResourceConfig	prb-Num	12	25
			prb-Start	0	0
			prb-End	23	49
			offsetIndicator	0	
			subframeBitmap	00000000 10000000 00000000 00000000 00000000 00000000	
		txParameters	not present		

## A.7.1.2 TDD

**Table A.7.1.2-1: ProSe Direct Discovery configuration for E-UTRA TDD Config 0 (Configuration #1-TDD)**

Information Element			Value
discRxPool	cp-Len		Normal
	discPeriod		rf32
	numRetx		0
	numRepetition		1
	tf-ResourceConfig	prb-Num	12
		prb-Start	0
		prb-End	23
		offsetIndicator	163
		subframeBitmap	10000000 00000000 00000000 00000000 00000000 00
	txParameters		not present
	rxParameters		not present
discTxPoolCommon			not present
discTxPowerInfo			not present
SL-SyncConfig			not present
discInterFreqList			not present

**Table A.7.1.2-2: ProSe Direct Discovery configuration for E-UTRA TDD (Configuration #2-TDD)**

Information Element			Value
discRxPool(iPool), iPool = 0...NPool-1	cp-Len		Normal
	discPeriod		rf32
	numRetx		3
	numRepetition		=2 if NPool > 10, =1 otherwise
	tf-ResourceConfig	prb-Num	5MHz: $\min\{24, 2N-24*iPool\} / 2$ 10MHz: 25 15MHz: $\min\{74, 2N-74*iPool\} / 2$ 20MHz: 50
		prb-Start	0
		prb-End	5 MHz: $\min\{24, 2N-24*iPool\} - 1$ 10 MHz: 49 15 MHz: $\min\{74, 2N-74*iPool\} - 1$ 20 MHz: 99
		offsetIndicator	163
		subframeBitmap	a(0), a(1), ..., a(39), s.t.  a(i * NPool + iPool) = 1, i = 0,...,K; a(k) = 0 otherwise  where K = 1 is NPool > 10, K = 3 otherwise
	txParameters		not present
	rxParameters		not present
discTxPoolCommon			not present
discTxPowerInfo			not present
SL-SyncConfig			not present
discInterFreqList			not present
NOTE 1: The resource pool configuration description is parameterized using channel BWs, number of configured resource pools (NPool), and maximum number of configured Sidelink UE to be supported (N).			

## A.7.2 Reference resource pool configurations for ProSe Direct Communication demodulation tests

### A.7.2.1 FDD

**Table A.7.2.1-1: ProSe Direct Communication pre-configuration for E-UTRAN FDD for out-of-network coverage operation (Configuration #1-FDD)**

Information Element / (BW configuration)			Value (5MHz)	Value (10MHz)	
preconfigSync	syncCP-Len-r12		Normal		
	syncOffsetIndicator1		1		
	syncOffsetIndicator2		2		
	syncTxParameters		23		
	syncTxThreshOoC		0 (-110dBm / 15kHz)		
	filterCoefficient		fc0		
	syncRefMinHyst		dB0		
preconfigComm	syncRefDiffHyst		dB0		
	sc-CP-Len		Normal		
	sc-Period		sf40		
	sc-TF-ResourceConfig	prb-Num		13	25
		prb-Start		0	0
		prb-End		24	49
		offsetIndicator		0	
		subframeBitmap		00011000 00000000 00000000 00000000 00000000	
	data-CP-Len			Normal	
	dataHoppingConfig		hoppingParameter		504
	numSubbands			ns2	
	rb-Offset			0	
ue-SelectedResourceConfig	data-TF-ResourceConfig	prb-Num	13	25	
		prb-Start	0	0	
		prb-End	24	49	
		offsetIndicator	0		
		subframeBitmap	00000000 11111111 11111111 00000000 00000000		
	trpt-Subset-r12		010		

Table A.7.2.1-2: ProSe Direct Communication configuration for E-UTRA FDD (Configuration #2-FDD)

Information Element / (BW configuration)				Value (5MHz)	Value (10MHz)
commRxPool	sc-CP-Len			Normal	
	sc-Period			sf40	
	sc-TF-ResourceConfig	prb-Num		13	25
		prb-Start		0	0
		prb-End		24	49
		offsetIndicator		0	
		subframeBitmap		00111100 00000000 00000000 00000000 00000000	
	data-CP-Len			Normal	
	dataHoppingConfig	hoppingParameter		504	
		numSubbands		ns2	
		rb-Offset		0	
	ue-SelectedResourceConfig	data-TF-ResourceConfig	prb-Num	13	25
			prb-Start	0	0
			prb-End	24	49
		offsetIndicator		0	
		subframeBitmap		00000000 11111111 11111111 00000000 00000000	
		trpt-Subset-r12		010	
	rxParametersNCell			not present	
	txParameters			not present	
commTxPoolNormalCommon				not present	
SL-SyncConfig				not present	

**Table A.7.2.1-3: ProSe Direct Communication configuration for E-UTRA FDD (Configuration #3-FDD)**

Information Element / (BW configuration)				Value (5MHz)	Value (10MHz)
commRxPool(0)	sc-CP-Len			Normal	
	sc-Period			sf40	
	sc-TF-ResourceConfig	prb-Num		13	25
		prb-Start		0	0
		prb-End		24	49
		offsetIndicator		0	
		subframeBitmap		00110000 00000000 00000000 00000000 00000000	
	data-CP-Len			Normal	
	dataHoppingConfig	hoppingParameter		504	
		numSubbands		ns2	
	rb-Offset		0		
ue-SelectedResourceConfig	data-TF-ResourceConfig	prb-Num	13	25	
		prb-Start	0	0	
		prb-End		24	49
		offsetIndicator		0	
		subframeBitmap		00001111 11110000 00000000 11111111 00000000	
		trpt-Subset-r12		010	
	rxParametersNCell		not present		
	txParameters		not present		
commRxPool(1)	sc-CP-Len			Normal	
	sc-Period			sf40	
	sc-TF-ResourceConfig	prb-Num		13	25
		prb-Start		0	0
		prb-End		24	49
		offsetIndicator		0	
		subframeBitmap		00110000 00000000 00000000 00000000 00000000	
	data-CP-Len			Normal	
	dataHoppingConfig	hoppingParameter		504	
		numSubbands		ns2	
	rb-Offset		0		
ue-SelectedResourceConfig	data-TF-ResourceConfig	prb-Num	13	25	
		prb-Start	0	0	
		prb-End		24	49
		offsetIndicator		0	
		subframeBitmap		00001111 11110000 00001111 11110000 00000000	
		trpt-Subset-r12		010	
	rxParametersNCell	tdc-Config	not present		
	txParameters	syncConfigIndex	0		
	txParameters		not present		
commTxPoolNormalCommon			not present		
SL-SyncConfig(0)	syncCP-Len		Normal		
	syncOffsetIndicator		1		
	slssid		30		
	txParameters		not present		
	rxParamsNCell	physCellId		1	
		discSyncWindow		w1	

Table A.7.2.1-4: ProSe Direct Communication configuration for E-UTRA FDD (Configuration #4-FDD)

Information Element / (BW configuration)				Value (5MHz)	Value (10MHz)
commRxPool(0)	sc-CP-Len			Normal	
	sc-Period			sf80	
	sc-TF-ResourceConfig	prb-Num		13	25
		prb-Start		0	0
		prb-End		24	49
		offsetIndicator		0	
		subframeBitmap		11110000 00000000 00000000 00000000 00000000	
commRxPool(1)	data-CP-Len			Normal	
	dataHoppingConfig	hoppingParameter		504	
		numSubbands		ns2	
		rb-Offset		0	
	ue-SelectedResourceConfig	data-TF-ResourceConfig	prb-Num	13	25
			prb-Start	0	0
			prb-End	24	49
		offsetIndicator	0		
	subframeBitmap		00000000 11111111 00000000 11111111 00000000		
	trpt-Subset-r12		001		
	rxParametersNCell		not present		
	txParameters		not present		
commTxPoolNormalCommon	sc-CP-Len			Normal	
	sc-Period			sf80	
	sc-TF-ResourceConfig	prb-Num		13	25
		prb-Start		0	0
		prb-End		24	49
		offsetIndicator		0	
		subframeBitmap		00001111 00000000 00000000 00000000 00000000	
	trpt-Subset-r12		001		
	rxParametersNCell		not present		
	txParameters		not present		
SL-SyncConfig			not present		



Table A.7.2.1-5: ProSe Direct Communication configuration for E-UTRA FDD (Configuration #5-FDD)

Information Element / (BW configuration)				Value (5MHz)	Value (10MHz)
commRxPool	sc-CP-Len			Normal	
	sc-Period			sf40	
	sc-TF-ResourceConfig	prb-Num		13	25
		prb-Start		0	0
		prb-End		24	49
		offsetIndicator		0	
		subframeBitmap		00011000 00000000 00000000 00000000 00000000	
	data-CP-Len			Normal	
	dataHoppingConfig	hoppingParameter		504	
		numSubbands		ns2	
		rb-Offset		0	
	ue-SelectedResourceConfig	data-TF-ResourceConfig	prb-Num	13	25
			prb-Start	0	0
			prb-End	24	49
		offsetIndicator		0	
		subframeBitmap		00000000 11111111 11111111 11111111 11111111	
		trpt-Subset-r12		001	
	rxParametersNCell			not present	
	txParameters			not present	
commTxPoolNormalCommon				not present	
SL-SyncConfig				not present	

## A.8 V2X reference measurement channels

### A.8.1 General

The algorithm for determining the payload size  $A$  is as follows; given a desired coding rate  $R$  and radio block allocation  $N_{RB}$

1. Calculate the number of channel bits  $N_{ch}$  that can be transmitted during the first transmission of a given sub-frame.
2. Find  $A$  such that the resulting coding rate is as close to  $R$  as possible, that is,

$$\min |R - (A + 24 * (N_{CB} + 1)) / N_{ch}|, \text{ where } N_{CB} = \begin{cases} 0, & \text{if } C = 1 \\ C, & \text{if } C > 1 \end{cases}$$

subject to

- a)  $A$  is a valid TB size according to section 7.1.7 of TS 36.213 [6] assuming an allocation of  $N_{RB}$  resource blocks.
  - b)  $C$  is the number of Code Blocks calculated according to section 5.1.2 of TS 36.212 [5].
3. If there is more than one  $A$  that minimizes the equation above, then the larger value is chosen per default and the chosen code rate should not exceed 0.93.

### A.8.1.1 Overview of V2X reference measurement channels

In Table A.8.1.1-1 are listed the Sidelink reference measurement channels specified in annexes A.8.2 to A.8.6 of this release of TS 36.101. This table is informative and serves only to a better overview. The reference for the concrete reference measurement channels and corresponding implementation's parameters as to be used for requirements are annexes A.8.2 to A.8.6 as appropriate.

**Table A.8.1.1-1: Overview of Sidelink reference measurement channels**

Table	Name	BW	Mod	TCR	RB	UE Categ	Notes
Table A.8.2-1	-	10	QPSK	1/3	48	SL-C Category 2 SL-C-RX Category $\geq 2$	
Table A.8.2-1	-	20	QPSK	1/3	96	SL-C Category 2 SL-C-RX Category $\geq 2$	
Table A.8.2-2	-	10	16QAM	2/3	48	SL-C Category 2 SL-C-RX Category $\geq 2$	
Table A.8.2-2	-	20	16QAM	2/3	96	SL-C Category 2 SL-C-RX Category $\geq 2$	
Table A.8.2-4	-	10	64QAM	3/4	48	SL-C-RX Category $\geq 3$	
Table A.8.2-4	-	20	64QAM	3/4	96	SL-C-RX Category $\geq 3$	
Table A.8.3-1		10/20	QPSK	1/3	-	SL-C Category 2 SL-C-TX Category $\geq 2$	
Table A.8.3-2		10/20	16QAM	2/3	-	SL-C Category 2 SL-C-TX Category $\geq 2$	
Table A.8.3-3		10/20	64QAM	3/4	-	SL-C-TX Category $\geq 3$	
Table A.8.4-1	CC.8	10/20	QPSK	-	2	-	
Table A.8.5-1	CD.8	20	16QAM	-	8	-	
Table A.8.5-1	CD.9	10	QPSK	-	3	-	
Table A.8.5-1	CD.10	20	QPSK	-	3	-	
Table A.8.5-1	CD.11	20	16QAM	-	96	-	
Table A.8.5-1	CD.12	20	QPSK	-	8	-	
Table A.8.5-2	CD.13	20	64QAM	-	8	-	
Table A.8.5-2	CD.14	10	QPSK	-	3	-	
Table A.8.5-2	CD.15	20	64QAM	-	96	-	
Table A.8.5-2	CD.16	10	64QAM	-	48	-	
Table A.8.5-2	CD.17	20	QPSK	-	8	-	
Table A.8.5-2	CD.18	10	QPSK	-	8	-	
Table A.8.5-2	CD.19	20	QPSK	-	3	-	
Table A.8.5-2	CD.20	10	QPSK	-	3	-	
Table A.8.6-1	CP.2	20	QPSK	-	6	-	

### A.8.2 Reference measurement channel for receiver characteristics

For V2X side link transmission over PC5, Table A.8.2-1 is applicable for measurements on the Receiver Characteristics (clause 7) with the exception of Maximum input level (subclause 7.4G). Table A.8.2-2 and Table A.8.2-3, are applicable for Maximum input level (subclause 7.4G).

**Table A.8.2-1 Fixed Reference measurement channel for V2X receiver requirements**

Parameter	Unit	Value					
		1.4	3	5	10	15	20
Channel bandwidth	MHz						
Allocated resource blocks					48		96
Subcarriers per resource block					12		12
Packets per period					1		1
Modulation					QPSK		QPSK
Target Coding Rate					1/3		1/3
Transport Block Size					3496		6968
Transport block CRC	Bits				24		24
Number of Code Blocks per Sub-Frame					1		2
Maximum number of HARQ transmissions					1		1
Binary Channel Bits per subframe	Bits				11520		23040
Max. Throughput averaged over 1 period of 100ms	kbps				34.96		69.68
UE Category					≥ 1		≥ 1

Note 1: 2RBs allocated to SA transmission and 4 symbols allocated to RS.  
Note 2: Throughput (in kbps) will depend on SA period configuration.  
Note 3: If more than one Code Block is present, an additional CRC sequence of L = 24 Bits is attached to each Code Block (otherwise L = 0 Bit).

**Table A.8.2-2 Fixed Reference measurement channel for V2X maximum input level requirements for 16QAM**

Parameter	Unit	Value					
		1.4	3	5	10	15	20
Channel bandwidth	MHz						
Allocated resource blocks					48		96
Subcarriers per resource block					12		12
Packets per period					1		1
Modulation					16QAM		16QAM
Target Coding Rate					2/3		2/3
Transport Block Size					15840		29296
Transport block CRC	Bits				24		24
Number of Code Blocks per Sub-Frame					3		5
Maximum number of HARQ transmissions					1		1
Binary Channel Bits per subframe	Bits				23040		46080
Max. Throughput averaged over 1 period of 100ms	kbps				158.4		292.96

Note 1: 2RBs allocated to SA transmission and 4 symbols allocated to RS.  
Note 2: Throughput (in kbps) will depend on SA period configuration.  
Note 3: If more than one Code Block is present, an additional CRC sequence of L = 24 Bits is attached to each Code Block (otherwise L = 0 Bit).

**Table A.8.2-3 (Void)**

**Table A.8.2-4 Fixed Reference measurement channel for V2X maximum input level for 64QAM**

Parameter	Unit	Value					
		1.4	3	5	10	15	20
Channel bandwidth	MHz						
Allocated resource blocks					48		96
Subcarriers per resource block					12		12
Packets per period					1		1
Modulation					64QAM		64QAM
Target Coding Rate					3/4		3/4
Transport Block Size					22920		46888
Transport block CRC	Bits				24		24
Number of Code Blocks per Sub-Frame					4		8
Maximum number of HARQ transmissions					1		1
Binary Channel Bits per subframe	Bits				31104		62208
Max. Throughput averaged over 1 period of 100ms	kbps				229.2		468.88
Note 1:	2RBs allocated to SA transmission, 4 symbols allocated to RS and the last symbol within a subframe is not considered in the mapping process						
Note 2:	Throughput (in kbps) will depend on SA period configuration.						
Note 3:	If more than one Code Block is present, an additional CRC sequence of L = 24 Bits is attached to each Code Block (otherwise L = 0 Bit).						

### A.8.3 Reference measurement channel for transmitter characteristics

For V2X side link transmission over PC5, Table A.8.3-1 and Table A.8.3-2 are applicable for measurements on the Transmitter Characteristics (clause 6).

Table A.8.3-1 Fixed Reference measurement channel for V2X Transmitter requirements for QPSK

Parameter	Ch BW	Allocated RBs	DFT-OFDM Symbols per Sub-Frame	Mod'n	Target Coding rate	Payload size	Transport block CRC	Number of code blocks per Sub-Frame (Note 1)	Total number of bits per Sub-Frame	Total symbols per Sub-Frame
Unit	MHz					Bits	Bits		Bits	
	10, 20	3	10	QPSK	1/3	208	24	1	720	360
	10, 20	4	10	QPSK	1/3	256	24	1	960	480
	10, 20	5	10	QPSK	1/3	328	24	1	1200	600
	10, 20	6	10	QPSK	1/3	408	24	1	1440	720
	10, 20	8	10	QPSK	1/3	552	24	1	1920	960
	10, 20	9	10	QPSK	1/3	632	24	1	2160	1080
	10, 20	10	10	QPSK	1/3	696	24	1	2400	1200
	10, 20	12	10	QPSK	1/3	840	24	1	2880	1440
	10, 20	15	10	QPSK	1/3	1064	24	1	3600	1800
	10, 20	16	10	QPSK	1/3	1128	24	1	3840	1920
	10, 20	18	10	QPSK	1/3	1288	24	1	4320	2160
	10, 20	20	10	QPSK	1/3	1416	24	1	4800	2400
	10, 20	24	10	QPSK	1/3	1736	24	1	5760	2880
	10, 20	25	10	QPSK	1/3	1800	24	1	6000	3000
	10, 20	27	10	QPSK	1/3	1928	24	1	6480	3240
	10, 20	30	10	QPSK	1/3	2152	24	1	7200	3600
	10, 20	32	10	QPSK	1/3	2280	24	1	7680	3840
	10, 20	36	10	QPSK	1/3	2600	24	1	8640	4320
	10, 20	40	10	QPSK	1/3	2856	24	1	9600	4800
	10, 20	45	10	QPSK	1/3	3240	24	1	10800	5400
	10, 20	48	10	QPSK	1/3	3496	24	1	11520	5760
	20	50	10	QPSK	1/3	3624	24	1	24000	12000
	20	54	10	QPSK	1/3	4776	24	1	25920	12960
	20	60	10	QPSK	1/3	5352	24	1	28800	14400
	20	64	10	QPSK	1/3	4584	24	1	30720	15360
	20	72	10	QPSK	1/3	5160	24	1	34560	17280
	20	75	10	QPSK	1/3	5352	24	1	36000	18000
	20	80	10	QPSK	1/3	5736	24	1	38400	19200
	20	81	10	QPSK	1/3	5736	24	1	38880	19440
	20	90	10	QPSK	1/3	6456	24	2	43200	21600
	20	96	10	QPSK	1/3	6968	24	2	46080	23040

Table A.8.3-2 Fixed Reference measurement channel for V2X Transmitter requirements for 16QAM

Parameter	Ch BW	Allocated RBs	DFT-OFDM Symbols per Sub-Frame	Mod'n	Target Coding rate	Payload size	Transport block CRC	Number of code blocks per Sub-Frame (Note 1)	Total number of bits per Sub-Frame	Total symbols per Sub-Frame
Unit	MHz					Bits	Bits		Bits	
10, 20	20	3	10	16QAM	2/3	904	24	1	1440	360
10, 20	20	4	10	16QAM	2/3	1224	24	1	1920	480
10, 20	20	5	10	16QAM	2/3	1544	24	1	2400	600
10, 20	20	6	10	16QAM	2/3	1800	24	1	2880	720
10, 20	20	8	10	16QAM	2/3	2472	24	1	3840	960
10, 20	20	9	10	16QAM	2/3	2728	24	1	4320	1080
10, 20	20	10	10	16QAM	2/3	3112	24	1	4800	1200
10, 20	20	12	10	16QAM	2/3	3624	24	1	5760	1440
10, 20	20	15	10	16QAM	2/3	4584	24	1	7200	1800
10, 20	20	16	10	16QAM	2/3	4968	24	1	7680	1920
10, 20	20	18	10	16QAM	2/3	5544	24	1	8640	2160
10, 20	20	20	10	16QAM	2/3	6200	24	2	9600	2400
10, 20	20	24	10	16QAM	2/3	7736	24	2	11520	2880
10, 20	20	25	10	16QAM	2/3	7992	24	2	12000	3000
10, 20	20	27	10	16QAM	2/3	8760	24	2	12960	3240
10, 20	20	30	10	16QAM	2/3	9912	24	2	14400	3600
10, 20	20	32	10	16QAM	2/3	10296	24	2	15360	3840
10, 20	20	36	10	16QAM	2/3	11832	24	2	17280	4320
10, 20	20	40	10	16QAM	2/3	12960	24	3	19200	4800
10, 20	20	45	10	16QAM	2/3	14688	24	3	21600	5400
10, 20	20	48	10	16QAM	2/3	15840	24	3	23040	5760
20	20	50	10	16QAM	2/3	16416	24	3	24000	6000
20	20	54	10	16QAM	2/3	17568	24	3	25920	6480
20	20	60	10	16QAM	2/3	18336	24	3	28800	7200
20	20	64	10	16QAM	2/3	20616	24	4	30720	7680
20	20	72	10	16QAM	2/3	23688	24	4	34560	8640
20	20	75	10	16QAM	2/3	24496	24	4	36000	9000
20	20	80	10	16QAM	2/3	26416	24	5	38400	9600
20	20	81	10	16QAM	2/3	26416	24	5	38880	9720
20	20	90	10	16QAM	2/3	29296	24	5	43200	10800
20	20	96	10	16QAM	2/3	29296	24	5	46080	11520

Table A.8.3-3 Fixed Reference measurement channel for V2X Transmitter requirements for 64QAM

Parameter	Ch BW	Allocated RBs	DFT-OFDM Symbols per Sub-Frame	Mod'n	Target Coding rate	Payload size	Transport block CRC	Number of code blocks per Sub-Frame (Note 1)	Total number of bits per Sub-Frame	Total symbols per Sub-Frame
Unit	MHz					Bits	Bits		Bits	
10, 20	3	9	64QAM	3/4	1480	24	1	1944	324	
10, 20	4	9	64QAM	3/4	1864	24	1	2592	432	
10, 20	5	9	64QAM	3/4	2408	24	1	3240	540	
10, 20	6	9	64QAM	3/4	2984	24	1	3888	648	
10, 20	8	9	64QAM	3/4	3752	24	1	5184	864	
10, 20	9	9	64QAM	3/4	4392	24	1	5832	972	
10, 20	10	9	64QAM	3/4	4968	24	1	6480	1080	
10, 20	12	9	64QAM	3/4	5736	24	1	7776	1296	
10, 20	15	9	64QAM	3/4	7224	24	2	9720	1620	
10, 20	16	9	64QAM	3/4	7480	24	2	10368	1728	
10, 20	18	9	64QAM	3/4	8760	24	2	11664	1944	
10, 20	20	9	64QAM	3/4	9912	24	2	12960	2160	
10, 20	24	9	64QAM	3/4	11448	24	2	15552	2592	
10, 20	25	9	64QAM	3/4	12216	24	2	16200	2700	
10, 20	27	9	64QAM	3/4	12960	24	3	17496	2916	
10, 20	30	9	64QAM	3/4	14688	24	3	19440	3240	
10, 20	32	9	64QAM	3/4	15264	24	3	20736	3456	
10, 20	36	9	64QAM	3/4	17568	24	3	23328	3888	
10, 20	40	9	64QAM	3/4	19848	24	4	25920	4320	
10, 20	45	9	64QAM	3/4	22152	24	4	29160	4860	
10, 20	48	9	64QAM	3/4	22920	24	4	31104	5184	
20	50	9	64QAM	3/4	24496	24	4	32400	5400	
20	54	9	64QAM	3/4	26416	24	5	34992	5832	
20	60	9	64QAM	3/4	29296	24	5	38880	6480	
20	64	9	64QAM	3/4	31704	24	6	41472	6912	
20	72	9	64QAM	3/4	35160	24	6	46656	7776	
20	75	9	64QAM	3/4	36696	24	6	48600	8100	
20	80	9	64QAM	3/4	39232	24	7	51840	8640	
20	81	9	64QAM	3/4	39232	24	7	52488	8748	
20	90	9	64QAM	3/4	43816	24	8	58320	9720	
20	96	9	64QAM	3/4	46888	24	8	62208	10368	

## A.8.4 Reference measurement for PSCCH performance requirements

Table A.8.4-1: Fixed reference measurement channel for PSCCH performance requirement

Parameter	Unit	Value
Reference channel		CC.8
Allocated resource blocks		2
DFT-OFDM Symbols per subframe (see Note 1)		9
Modulation		QPSK
Payload (without CRC)	Bits	32
CRC	Bits	16
SCI Format		1
Number of PSCCH transmissions		1
Binary Channel Bits (see Note 2)	Bits	432
Note 1: PSCCH transmissions are rate-matched for 10 DFT-OFDM symbols per subframe, and the last symbol shall be punctured as per TS 36.211.		
Note 2: Binary Channel Bits are calculated under assumption of 9 symbols.		
Note 3: Un-used or redundant bits/code-points in SCI format 1 are randomized.		

## A.8.5 Reference measurement for PSSCH performance requirements

**Table A.8.5-1: Fixed reference measurement channel for PSSCH performance requirement**

Parameter	Unit	Value				
		CD.8	CD.9	CD.10	CD.11	CD.12
Reference channel		CD.8	CD.9	CD.10	CD.11	CD.12
Channel bandwidth	MHz	20	10	20	20	20
Allocated resource blocks		8	3	3	96	8
DFT-OFDM Symbols per subframe (see Note 1)		9	9	9	9	9
Modulation		16QAM	QPSK	QPSK	16QAM	QPSK
Transport Block Size	Bits	1800	208	504	31704	552
Transport block CRC	Bits	24	24	24	24	24
Number of PSSCH transmissions		1	2	1	2	1
Binary Channel Bits (see Note 2)	Bits	3456	648	648	41472	1728
Note 1: PSSCH transmissions are rate-matched for 10 DFT-OFDM symbols per subframe, and the last symbol shall be punctured as per TS 36.211.						
Note 2: Binary Channel Bits are calculated under assumption of 9 symbols.						
Note 3: If more than one Code Block is present, an additional CRC sequence of L = 24 Bits is attached to each Code Block (otherwise L = 0 Bit).						

**Table A.8.5-2: Fixed reference measurement channel for PSSCH performance requirement**

Parameter	Unit	Value							
		CD.13	CD.14	CD.15	CD.16	CD.17	CD.18	CD.19	CD.20
Reference channel		CD.13	CD.14	CD.15	CD.16	CD.17	CD.18	CD.19	CD.20
Channel bandwidth	MHz	20	10	20	10	20	10	20	10
Allocated resource blocks		8	3	96	48	8	8	3	3
DFT-OFDM Symbols per subframe (see Note 1)		9	9	9	9	9	9	9	9
Modulation		64QAM	QPSK	64QAM	64QAM	QPSK	QPSK	QPSK	QPSK
Transport Block Size	Bits	2600	120	48936	24496	408	408	120	120
Transport block CRC	Bits	24	24	24	24	24	24	24	24
Number of PSSCH transmissions		2	2	2	2	1	1	1	1
Binary Channel Bits (see Note 2)	Bits	5184	648	62208	31104	1728	1728	648	648
Note 1: PSSCH transmissions are rate-matched for 9 DFT-OFDM symbols per subframe.									
Note 2: Binary Channel Bits are calculated under assumption of 9 symbols.									
Note 3: If more than one Code Block is present, an additional CRC sequence of L = 24 Bits is attached to each Code Block (otherwise L = 0 Bit).									

## A.8.6 Reference measurement for PSBCH performance requirements

**Table A.8.6-1: Fixed reference measurement channel for PSBCH performance requirement**

Parameter	Unit	Value
Reference channel		CP.2
Channel bandwidth	MHz	20
Allocated resource blocks		6
DFT-OFDM Symbols per subframe (see Note 1)		6
Modulation		QPSK
Transport Block Size	Bits	48
Transport block CRC	Bits	16
Binary Channel Bits (see Note 2)	Bits	864
Note 1: PSBCH transmissions are rate-matched for 7 DFT-OFDM symbols per subframe, and the last symbol shall be punctured as per TS 36.211.		
Note 2: Binary Channel Bits are calculated under assumption of 6 symbols.		



## A.9 V2X reference resource pool configurations

Table A.9-1: V2X sidelink communication pre-configuration for PSSCH/PSCCH tests (Configuration #1-V2X)

Information Element			Value (10MHz)	Value (20MHz)
SL-V2X-PreconfigCommPool-r14	sl-OffsetIndicator-r14		0	
	sl-Subframe-r14	bs20-r14	0xFFFF	
	adjacencyPSCCH-PSSCH-r14		TRUE	
	sizeSubchannel-r14		n5	n10
	numSubchannel-r14		n1	
	startRB-Subchannel-r14		0	
	startRB-PSCCH-Pool-r14		not present	
	dataTxParameters-r14	P0-SL-r12	-126	
	zoneID-r14		not present	
	threshS-RSSI-CBR-r14		not present	
	cbr-pssch-TxConfigList-r14		not present	
	resourceSelectionConfigP2X-r14		not present	
	syncAllowed-r14		not present	
	restrictResourceReservationPeriod-r14		not present	

Table A.9-2: V2X sidelink communication pre-configuration for power imbalance test (Configuration #2-V2X)

Information Element			Value (20MHz)
SL-V2X-PreconfigCommPool-r14	sl-OffsetIndicator-r14		0
	sl-Subframe-r14	bs20-r14	0xFFFF
	adjacencyPSCCH-PSSCH-r14		TRUE
	sizeSubchannel-r14		n5
	numSubchannel-r14		n10
	startRB-Subchannel-r14		0
	startRB-PSCCH-Pool-r14		not present
	dataTxParameters-r14	P0-SL-r12	-126
	zoneID-r14		not present
	threshS-RSSI-CBR-r14		not present
	cbr-pssch-TxConfigList-r14		not present
	resourceSelectionConfigP2X-r14		not present
	syncAllowed-r14		not present
	restrictResourceReservationPeriod-r14		not present

**Table A.9-3: V2X sidelink communication configuration for PSSCH with eNB based synchronization test (Configuration #3-V2X)**

Information Element			Value (20MHz)
SL-CommResourcePoolV2X-r14	sl-OffsetIndicator-r14		0
	sl-Subframe-r14	bs20-r14	0xFFFF
	adjacencyPSCCH-PSSCH-r14		TRUE
	sizeSubchannel-r14		n10
	numSubchannel-r14		n1
	startRB-Subchannel-r14		0
	startRB-PSCCH-Pool-r14		not present
	rxParametersNCell-r14		not present
	dataTxParameters-r14	P0-SL-r12	-126
	zoneID-r14		not present
	threshS-RSSI-CBR-r14		not present
	poolReportId-r14		not present
	cbr-pssch-TxConfigList-r14		not present
	resourceSelectionConfigP2X-r14		not present
	syncAllowed-r14		not present
	restrictResourceReservationPeriod-r14		not present
SL-TypeTxSync-r14			enb

**Table A.9-4: V2X sidelink communication pre-configuration for soft buffer test (Configuration #4-V2X)**

Information Element			Value (10MHz)	Value (20MHz)
SL-V2X-PreconfigCommPool-r14	sl-OffsetIndicator-r14		0	
	sl-Subframe-r14	bs20-r14	0xFFFF	
	adjacencyPSCCH-PSSCH-r14		TRUE	
	sizeSubchannel-r14		n50	n100
	numSubchannel-r14		n1	
	startRB-Subchannel-r14		0	
	startRB-PSCCH-Pool-r14		not present	
	dataTxParameters-r14	P0-SL-r12	-126	
	zoneID-r14		not present	
	threshS-RSSI-CBR-r14		not present	
	cbr-pssch-TxConfigList-r14		not present	
	resourceSelectionConfigP2X-r14		not present	
	syncAllowed-r14		not present	
	restrictResourceReservationPeriod-r14		not present	

**Table A.9-5: V2X sidelink communication pre-configuration for PSCCH/PSSCH decoding capability test (Configuration #5-V2X)**

Information Element		Value (20MHz)	
SL-V2X-PreconfigCommPool-r14	sl-OffsetIndicator-r14		0
	sl-Subframe-r14	bs20-r14	0xFFFFF
	adjacencyPSCCH-PSSCH-r14		TRUE
	sizeSubchannel-r14		n10   n5
	numSubchannel-r14		n10   n20
	startRB-Subchannel-r14		0
	startRB-PSCCH-Pool-r14		not present
	dataTxParameters-r14	P0-SL-r12	-126
	zoneID-r14		not present
	threshS-RSSI-CBR-r14		not present
	cbr-pssch-TxConfigList-r14		not present
	resourceSelectionConfigP2X-r14		not present
	syncAllowed-r14		not present
	restrictResourceReservationPeriod-r14		not present

**Table A.9-6: V2X sidelink communication pre-configuration for PSCCH/PSSCH decoding capability test (Configuration #6-V2X)**

Information Element		Value (10MHz)	
SL-V2X-PreconfigCommPool-r14	sl-OffsetIndicator-r14		0
	sl-Subframe-r14	bs20-r14	0xFFFFF
	adjacencyPSCCH-PSSCH-r14		TRUE
	sizeSubchannel-r14		n10   n5
	numSubchannel-r14		n5   n10
	startRB-Subchannel-r14		0
	startRB-PSCCH-Pool-r14		not present
	dataTxParameters-r14	P0-SL-r12	-126
	zoneID-r14		not present
	threshS-RSSI-CBR-r14		not present
	cbr-pssch-TxConfigList-r14		not present
	resourceSelectionConfigP2X-r14		not present
	syncAllowed-r14		not present
	restrictResourceReservationPeriod-r14		not present

## Annex B (normative): Propagation conditions

### B.1 Static propagation condition

#### B.1.1 UE Receiver with 2Rx

For 1 port transmission the channel matrix is defined in the frequency domain by

$$\mathbf{H} = \begin{pmatrix} 1 \\ 1 \end{pmatrix}.$$

For 2 port transmission the channel matrix is defined in the frequency domain by

$$\mathbf{H} = \begin{pmatrix} 1 & j \\ 1 & -j \end{pmatrix}.$$

For 4 port transmission the channel matrix is defined in the frequency domain by

$$\mathbf{H} = \begin{bmatrix} 1 & 1 & j & j \\ 1 & 1 & -j & -j \end{bmatrix}$$

For 8 port transmission the channel matrix is defined in the frequency domain by

$$\mathbf{H} = \begin{bmatrix} 1 & 1 & 1 & 1 & j & j & j & j \\ 1 & 1 & 1 & 1 & -j & -j & -j & -j \end{bmatrix}$$

#### B.1.2 UE Receiver with 4Rx

For 1 port transmission the channel matrix is defined in the frequency domain by

$$\mathbf{H} = \begin{bmatrix} 1 \\ 1 \\ 1 \\ 1 \end{bmatrix}.$$

For 2 port transmission the channel matrix is defined in the frequency domain by

$$\mathbf{H} = \begin{bmatrix} 1 & j \\ 1 & -j \\ 1 & j \\ 1 & -j \end{bmatrix}.$$

For 4 port transmission the channel matrix is defined in the frequency domain by

$$\mathbf{H} = \begin{bmatrix} 1 & 1 & j & j \\ 1 & 1 & -j & -j \\ 1 & -1 & j & -j \\ 1 & -1 & -j & j \end{bmatrix}.$$

For 8 port transmission the channel matrix is defined in the frequency domain by

$$\mathbf{H} = \begin{bmatrix} 1 & 1 & 1 & 1 & j & j & j & j \\ 1 & 1 & 1 & 1 & -j & -j & -j & -j \\ 1 & 1 & -1 & -1 & j & j & -j & -j \\ 1 & 1 & -1 & -1 & -j & -j & j & j \end{bmatrix}$$

### B.1.3 UE Receiver with 8Rx

For 1 port transmission the channel matrix is defined in the frequency domain by

$$\mathbf{H} = \begin{bmatrix} 1 \\ 1 \\ 1 \\ 1 \\ 1 \\ 1 \\ 1 \\ 1 \\ 1 \end{bmatrix}.$$

For 2 port transmission the channel matrix is defined in the frequency domain by

$$\mathbf{H} = \begin{bmatrix} 1 & j \\ 1 & -j \\ 1 & j \\ 1 & -j \\ -1 & j \\ -1 & -j \\ -1 & j \\ -1 & -j \end{bmatrix}.$$

For 4 port transmission the channel matrix is defined in the frequency domain by

$$\mathbf{H} = \begin{bmatrix} 1 & 1 & j & j \\ 1 & 1 & -j & -j \\ 1 & 1 & j & -j \\ 1 & 1 & -j & j \\ 1 & -1 & j & j \\ 1 & -1 & -j & -j \\ 1 & -1 & j & -j \\ 1 & -1 & -j & j \end{bmatrix}$$

For 8 port transmission the channel matrix is defined in the frequency domain by

$$\mathbf{H} = \begin{bmatrix} 1 & 1 & 1 & 1 & j & j & j & j \\ 1 & 1 & 1 & 1 & -j & -j & -j & -j \\ 1 & 1 & -1 & -1 & j & j & -j & -j \\ 1 & 1 & -1 & -1 & -j & -j & j & j \\ 1 & -1 & 1 & -1 & j & -j & j & -j \\ 1 & -1 & 1 & -1 & -j & j & -j & j \\ 1 & -1 & -1 & 1 & j & -j & -j & j \\ 1 & -1 & -1 & 1 & -j & j & j & -j \end{bmatrix}$$

## B.2 Multi-path fading propagation conditions

The multipath propagation conditions consist of several parts:

- A delay profile in the form of a "tapped delay-line", characterized by a number of taps at fixed positions on a sampling grid. The profile can be further characterized by the r.m.s. delay spread and the maximum delay spanned by the taps.
- A combination of channel model parameters that include the Delay profile and the Doppler spectrum, that is characterized by a classical spectrum shape and a maximum Doppler frequency
- A set of correlation matrices defining the correlation between the UE and eNodeB antennas in case of multi-antenna systems.
- Additional multi-path models used for CQI (Channel Quality Indication) tests

### B.2.1 Delay profiles

The delay profiles are selected to be representative of low, medium and high delay spread environments. The resulting model parameters are defined in Table B.2.1-1 and the tapped delay line models are defined in Tables B.2.1-2, B.2.1-3 and B.2.1-4.

**Table B.2.1-1 Delay profiles for E-UTRA channel models**

Model	Number of channel taps	Delay spread (r.m.s.)	Maximum excess tap delay (span)
Extended Pedestrian A (EPA)	7	43 ns	410 ns
Extended Vehicular A model (EVA)	9	357 ns	2510 ns
Extended Typical Urban model (ETU)	9	991 ns	5000 ns

**Table B.2.1-2 Extended Pedestrian A model (EPA)**

Excess tap delay [ns]	Relative power [dB]
0	0.0
30	-1.0
70	-2.0
90	-3.0
110	-8.0
190	-17.2
410	-20.8

**Table B.2.1-3 Extended Vehicular A model (EVA)**

Excess tap delay [ns]	Relative power [dB]
0	0.0
30	-1.5
150	-1.4
310	-3.6
370	-0.6
710	-9.1
1090	-7.0
1730	-12.0
2510	-16.9

**Table B.2.1-4 Extended Typical Urban model (ETU)**

Excess tap delay [ns]	Relative power [dB]
0	-1.0
50	-1.0
120	-1.0
200	0.0
230	0.0
500	0.0
1600	-3.0
2300	-5.0
5000	-7.0

## B.2.2 Combinations of channel model parameters

The propagation conditions used for the performance measurements in multi-path fading environment are indicated as EVA[number], EPA[number] or ETU[number] where 'number' indicates the maximum Doppler frequency (Hz).

**Table B.2.2-1 Void**

## B.2.3 MIMO Channel Correlation Matrices

The MIMO channel correlation matrices defined in B.2.3 apply for the antenna configuration using uniform linear arrays at both eNodeB and UE.

### B.2.3.1 Definition of MIMO Correlation Matrices

Table B.2.3.1-1 defines the correlation matrix for the eNodeB

**Table B.2.3.1-1 eNodeB correlation matrix**

	One antenna	Two antennas	Four antennas	Eight antennas
eNode B Correlation	$R_{eNB} = 1$	$R_{eNB} = \begin{pmatrix} 1 & \alpha \\ \alpha^* & \mathbf{1} \end{pmatrix}$	$R_{eNB} = \begin{pmatrix} 1 & \alpha^{1/9} & \alpha^{4/9} & \alpha \\ \alpha^{1/9*} & 1 & \alpha^{1/9} & \alpha^{4/9} \\ \alpha^{4/9*} & \alpha^{1/9*} & 1 & \alpha^{1/9} \\ \alpha^* & \alpha^{4/9*} & \alpha^{1/9*} & 1 \end{pmatrix}$	$R_{eNB} = \begin{pmatrix} 1 & \alpha^{1/49} & \alpha^{4/49} & \alpha^{9/49} & \alpha^{16/49} & \alpha^{25/49} & \alpha^{36/49} & \alpha \\ \alpha^{1/49*} & 1 & \alpha^{1/49} & \alpha^{4/49} & \alpha^{9/49} & \alpha^{16/49} & \alpha^{25/49} & \alpha^{36/49} \\ \alpha^{4/49*} & \alpha^{1/49*} & 1 & \alpha^{1/49} & \alpha^{4/49} & \alpha^{9/49} & \alpha^{16/49} & \alpha^{25/49} \\ \alpha^{9/49*} & \alpha^{4/49*} & \alpha^{1/49*} & 1 & \alpha^{1/49} & \alpha^{4/49} & \alpha^{9/49} & \alpha^{16/49} \\ \alpha^{16/49*} & \alpha^{9/49*} & \alpha^{4/49*} & \alpha^{1/49*} & 1 & \alpha^{1/49} & \alpha^{4/49} & \alpha^{9/49} \\ \alpha^{25/49*} & \alpha^{16/49*} & \alpha^{9/49*} & \alpha^{4/49*} & \alpha^{1/49*} & 1 & \alpha^{1/49} & \alpha^{4/49} \\ \alpha^{36/49*} & \alpha^{25/49*} & \alpha^{16/49*} & \alpha^{9/49*} & \alpha^{4/49*} & \alpha^{1/49*} & 1 & \alpha^{1/49} \\ \alpha^* & \alpha^{36/49*} & \alpha^{25/49*} & \alpha^{16/49*} & \alpha^{9/49*} & \alpha^{4/49*} & \alpha^{1/49*} & 1 \end{pmatrix}$

Table B.2.3.1-2 defines the correlation matrix for the UE:



Table B.2.3.1-2 UE correlation matrix

	One antenna	Two antennas	Four antennas	Eight antennas
UE Correlation	$R_{UE} = 1$	$R_{UE} = \begin{pmatrix} 1 & \beta \\ \beta^* & \mathbf{1} \end{pmatrix}$	$R_{UE} = \begin{pmatrix} 1 & \beta^{1/9} & \beta^{4/9} & \beta \\ \beta^{1/9*} & 1 & \beta^{1/9} & \beta^{4/9} \\ \beta^{4/9*} & \beta^{1/9*} & 1 & \beta^{1/9} \\ \beta^* & \beta^{4/9*} & \beta^{1/9*} & 1 \end{pmatrix}$	$R_{UE} = \begin{pmatrix} 1 & \beta^{1/49} & \beta^{4/49} & \beta^{9/49} & \beta^{16/49} & \beta^{25/49} & \beta^{36/49} & \beta \\ \beta^{1/49*} & 1 & \beta^{1/49} & \beta^{4/49} & \beta^{9/49} & \beta^{16/49} & \beta^{25/49} & \beta^{36/49} \\ \beta^{4/49*} & \beta^{1/49*} & 1 & \beta^{1/49} & \beta^{4/49} & \beta^{9/49} & \beta^{16/49} & \beta^{25/49} \\ \beta^{9/49*} & \beta^{4/49*} & \beta^{1/49*} & 1 & \beta^{1/49} & \beta^{4/49} & \beta^{9/49} & \beta^{16/49} \\ \beta^{16/49*} & \beta^{9/49*} & \beta^{4/49*} & \beta^{1/49*} & 1 & \beta^{1/49} & \beta^{4/49} & \beta^{9/49} \\ \beta^{25/49*} & \beta^{16/49*} & \beta^{9/49*} & \beta^{4/49*} & \beta^{1/49*} & 1 & \beta^{1/49} & \beta^{4/49} \\ \beta^{36/49*} & \beta^{25/49*} & \beta^{16/49*} & \beta^{9/49*} & \beta^{4/49*} & \beta^{1/49*} & 1 & \beta^{1/49} \\ \beta^* & \beta^{36/49*} & \beta^{25/49*} & \beta^{16/49*} & \beta^{9/49*} & \beta^{4/49*} & \beta^{1/49*} & 1 \end{pmatrix}$

Table B.2.3.1-3 defines the channel spatial correlation matrix  $R_{spat}$ . The parameters,  $\alpha$  and  $\beta$  in Table B.2.3.1-3 defines the spatial correlation between the antennas at the eNodeB and UE.

**Table B.2.3.1-3:  $R_{spat}$  correlation matrices**

1x2 case	$R_{spat} = R_{UE} = \begin{bmatrix} 1 & \beta \\ \beta^* & 1 \end{bmatrix}$
1x4 case	$R_{spat} = R_{UE} = \begin{bmatrix} 1 & \beta^{1/9} & \beta^{4/9} & \beta \\ \beta^{1/9*} & 1 & \beta^{1/9} & \beta^{4/9} \\ \beta^{4/9*} & \beta^{1/9*} & 1 & \beta^{1/9} \\ \beta^* & \beta^{4/9*} & \beta^{1/9*} & 1 \end{bmatrix}$
2x1 case	$R_{spat} = R_{eNB} = \begin{bmatrix} 1 & \alpha \\ \alpha^* & 1 \end{bmatrix}$
2x2 case	$R_{spat} = R_{eNB} \otimes R_{UE} = \begin{bmatrix} 1 & \alpha \\ \alpha^* & 1 \end{bmatrix} \otimes \begin{bmatrix} 1 & \beta \\ \beta^* & 1 \end{bmatrix} = \begin{bmatrix} 1 & \beta & \alpha & \alpha\beta \\ \beta^* & 1 & \alpha\beta^* & \alpha \\ \alpha^* & \alpha^*\beta & 1 & \beta \\ \alpha^*\beta^* & \alpha^* & \beta^* & 1 \end{bmatrix}$
2x4 case	$R_{spat} = R_{eNB} \otimes R_{UE} = \begin{bmatrix} 1 & \alpha \\ \alpha^* & 1 \end{bmatrix} \otimes \begin{bmatrix} 1 & \beta^{1/9} & \beta^{4/9} & \beta \\ \beta^{1/9*} & 1 & \beta^{1/9} & \beta^{4/9} \\ \beta^{4/9*} & \beta^{1/9*} & 1 & \beta^{1/9} \\ \beta^* & \beta^{4/9*} & \beta^{1/9*} & 1 \end{bmatrix}$
4x1 case	$R_{spat} = R_{eNB} = \begin{bmatrix} 1 & \alpha^{1/9} & \alpha^{4/9} & \alpha \\ \alpha^{1/9*} & 1 & \alpha^{1/9} & \alpha^{4/9} \\ \alpha^{4/9*} & \alpha^{1/9*} & 1 & \alpha^{1/9} \\ \alpha^* & \alpha^{4/9*} & \alpha^{1/9*} & 1 \end{bmatrix}$
4x2 case	$R_{spat} = R_{eNB} \otimes R_{UE} = \begin{bmatrix} 1 & \alpha^{1/9} & \alpha^{4/9} & \alpha \\ \alpha^{1/9*} & 1 & \alpha^{1/9} & \alpha^{4/9} \\ \alpha^{4/9*} & \alpha^{1/9*} & 1 & \alpha^{1/9} \\ \alpha^* & \alpha^{4/9*} & \alpha^{1/9*} & 1 \end{bmatrix} \otimes \begin{bmatrix} 1 & \beta \\ \beta^* & 1 \end{bmatrix}$

<p>4x4 case</p>	$R_{spat} = R_{eNB} \otimes R_{UE} = \begin{bmatrix} 1 & \alpha^{1/9} & \alpha^{4/9} & \alpha \\ \alpha^{1/9} & 1 & \alpha^{1/9} & \alpha^{4/9} \\ \alpha^{4/9} & \alpha^{1/9} & 1 & \alpha^{1/9} \\ \alpha^* & \alpha^{4/9} & \alpha^{1/9} & 1 \end{bmatrix} \otimes \begin{pmatrix} 1 & \beta^{1/9} & \beta^{4/9} & \beta \\ \beta^{1/9*} & 1 & \beta^{1/9} & \beta^{4/9} \\ \beta^{4/9*} & \beta^{1/9*} & 1 & \beta^{1/9} \\ \beta^* & \beta^{4/9*} & \beta^{1/9*} & 1 \end{pmatrix}$
<p>2x8 case</p>	$R_{spat} = R_{eNB} \otimes R_{UE} = \begin{bmatrix} 1 & \alpha \\ \alpha^* & 1 \end{bmatrix} \otimes \begin{pmatrix} 1 & \beta^{1/49} & \beta^{4/49} & \beta^{9/49} & \beta^{16/49} & \beta^{25/49} & \beta^{36/49} & \beta \\ \beta^{1/49*} & 1 & \beta^{1/49} & \beta^{4/49} & \beta^{9/49} & \beta^{16/49} & \beta^{25/49} & \beta^{36/49} \\ \beta^{4/49*} & \beta^{1/49*} & 1 & \beta^{1/49} & \beta^{4/49} & \beta^{9/49} & \beta^{16/49} & \beta^{25/49} \\ \beta^{9/49*} & \beta^{4/49*} & \beta^{1/49*} & 1 & \beta^{1/49} & \beta^{4/49} & \beta^{9/49} & \beta^{16/49} \\ \beta^{16/49*} & \beta^{9/49*} & \beta^{4/49*} & \beta^{1/49*} & 1 & \beta^{1/49} & \beta^{4/49} & \beta^{9/49} \\ \beta^{25/49*} & \beta^{16/49*} & \beta^{9/49*} & \beta^{4/49*} & \beta^{1/49*} & 1 & \beta^{1/49} & \beta^{4/49} \\ \beta^{36/49*} & \beta^{25/49*} & \beta^{16/49*} & \beta^{9/49*} & \beta^{4/49*} & \beta^{1/49*} & 1 & \beta^{1/49} \\ \beta^* & \beta^{36/49*} & \beta^{25/49*} & \beta^{16/49*} & \beta^{9/49*} & \beta^{4/49*} & \beta^{1/49*} & 1 \end{pmatrix}$
<p>4x8 case</p>	$R_{spat} = R_{eNB} \otimes R_{UE} = \begin{bmatrix} 1 & \alpha^{1/9} & \alpha^{4/9} & \alpha \\ \alpha^{1/9} & 1 & \alpha^{1/9} & \alpha^{4/9} \\ \alpha^{4/9} & \alpha^{1/9} & 1 & \alpha^{1/9} \\ \alpha^* & \alpha^{4/9} & \alpha^{1/9} & 1 \end{bmatrix} \otimes \begin{pmatrix} 1 & \beta^{1/49} & \beta^{4/49} & \beta^{9/49} & \beta^{16/49} & \beta^{25/49} & \beta^{36/49} & \beta \\ \beta^{1/49*} & 1 & \beta^{1/49} & \beta^{4/49} & \beta^{9/49} & \beta^{16/49} & \beta^{25/49} & \beta^{36/49} \\ \beta^{4/49*} & \beta^{1/49*} & 1 & \beta^{1/49} & \beta^{4/49} & \beta^{9/49} & \beta^{16/49} & \beta^{25/49} \\ \beta^{9/49*} & \beta^{4/49*} & \beta^{1/49*} & 1 & \beta^{1/49} & \beta^{4/49} & \beta^{9/49} & \beta^{16/49} \\ \beta^{16/49*} & \beta^{9/49*} & \beta^{4/49*} & \beta^{1/49*} & 1 & \beta^{1/49} & \beta^{4/49} & \beta^{9/49} \\ \beta^{25/49*} & \beta^{16/49*} & \beta^{9/49*} & \beta^{4/49*} & \beta^{1/49*} & 1 & \beta^{1/49} & \beta^{4/49} \\ \beta^{36/49*} & \beta^{25/49*} & \beta^{16/49*} & \beta^{9/49*} & \beta^{4/49*} & \beta^{1/49*} & 1 & \beta^{1/49} \\ \beta^* & \beta^{36/49*} & \beta^{25/49*} & \beta^{16/49*} & \beta^{9/49*} & \beta^{4/49*} & \beta^{1/49*} & 1 \end{pmatrix}$

<b>8x8 case</b>	$R_{spat} = R_{eNB} \otimes R_{UE} =$	1	$\alpha^{1/49}$	$\alpha^{4/49}$	$\alpha^{9/49}$	$\alpha^{16/49}$	$\alpha^{25/49}$	$\alpha^{36/49}$	$\alpha$	$\otimes$	1	$\beta^{1/49}$	$\beta^{4/49}$	$\beta^{9/49}$	$\beta^{16/49}$	$\beta^{25/49}$	$\beta^{36/49}$							
		$\alpha^{1/49*}$	1	$\alpha^{1/49}$	$\alpha^{4/49}$	$\alpha^{9/49}$	$\alpha^{16/49}$	$\alpha^{25/49}$	$\alpha^{36/49}$		$\beta^{1/49*}$	1	$\beta^{1/49}$	$\beta^{4/49}$	$\beta^{9/49}$	$\beta^{16/49}$	$\beta^{25/49}$	$\beta^{36/49}$						
		$\alpha^{4/49*}$	$\alpha^{1/49*}$	1	$\alpha^{1/49}$	$\alpha^{4/49}$	$\alpha^{9/49}$	$\alpha^{16/49}$	$\alpha^{25/49}$		$\beta^{4/49*}$	$\beta^{1/49*}$	1	$\beta^{1/49}$	$\beta^{4/49}$	$\beta^{9/49}$	$\beta^{16/49}$	$\beta^{25/49}$	$\beta^{36/49}$					
		$\alpha^{9/49*}$	$\alpha^{4/49*}$	$\alpha^{1/49*}$	1	$\alpha^{1/49}$	$\alpha^{4/49}$	$\alpha^{9/49}$	$\alpha^{16/49}$		$\beta^{9/49*}$	$\beta^{4/49*}$	$\beta^{1/49*}$	1	$\beta^{1/49}$	$\beta^{4/49}$	$\beta^{9/49}$	$\beta^{16/49}$	$\beta^{25/49}$	$\beta^{36/49}$				
		$\alpha^{16/49*}$	$\alpha^{9/49*}$	$\alpha^{4/49*}$	$\alpha^{1/49*}$	1	$\alpha^{1/49}$	$\alpha^{4/49}$	$\alpha^{9/49}$		$\beta^{16/49*}$	$\beta^{9/49*}$	$\beta^{4/49*}$	$\beta^{1/49*}$	1	$\beta^{1/49}$	$\beta^{4/49}$	$\beta^{9/49}$	$\beta^{16/49}$	$\beta^{25/49}$	$\beta^{36/49}$			
		$\alpha^{25/49*}$	$\alpha^{16/49*}$	$\alpha^{9/49*}$	$\alpha^{4/49*}$	$\alpha^{1/49*}$	1	$\alpha^{1/49}$	$\alpha^{4/49}$		$\beta^{25/49*}$	$\beta^{16/49*}$	$\beta^{9/49*}$	$\beta^{4/49*}$	$\beta^{1/49*}$	1	$\beta^{1/49}$	$\beta^{4/49}$	$\beta^{9/49}$	$\beta^{16/49}$	$\beta^{25/49}$	$\beta^{36/49}$		
		$\alpha^{36/49*}$	$\alpha^{25/49*}$	$\alpha^{16/49*}$	$\alpha^{9/49*}$	$\alpha^{4/49*}$	$\alpha^{1/49*}$	1	$\alpha^{1/49}$		$\beta^{36/49*}$	$\beta^{25/49*}$	$\beta^{16/49*}$	$\beta^{9/49*}$	$\beta^{4/49*}$	$\beta^{1/49*}$	1	$\beta^{1/49}$	$\beta^{4/49}$	$\beta^{9/49}$	$\beta^{16/49}$	$\beta^{25/49}$	$\beta^{36/49}$	
		$\alpha^*$	$\alpha^{36/49*}$	$\alpha^{25/49*}$	$\alpha^{16/49*}$	$\alpha^{9/49*}$	$\alpha^{4/49*}$	$\alpha^{1/49*}$	1		$\beta^*$	$\beta^{36/49*}$	$\beta^{25/49*}$	$\beta^{16/49*}$	$\beta^{9/49*}$	$\beta^{4/49*}$	$\beta^{1/49*}$	1	$\beta^{1/49}$	$\beta^{4/49}$	$\beta^{9/49}$	$\beta^{16/49}$	$\beta^{25/49}$	$\beta^{36/49}$

For cases with more antennas at either eNodeB or UE or both, the channel spatial correlation matrix can still be expressed as the Kronecker product of  $R_{eNB}$  and  $R_{UE}$  according to  $R_{spat} = R_{eNB} \otimes R_{UE}$ .

### B.2.3.2 MIMO Correlation Matrices at High, Medium and Low Level

The  $\alpha$  and  $\beta$  for different correlation types are given in Table B.2.3.2-1.

**Table B.2.3.2-1: The  $\alpha$  and  $\beta$  parameters for ULA MIMO correlation matrices**

Correlation Model	$\alpha$	$\beta$
Low correlation	0	0
Medium Correlation	0.3	0.9
Medium Correlation A	0.3	0.3874
Medium Correlation B	0.3	0.005154
High Correlation	0.9	0.9

The correlation matrices for high, medium, low and medium A correlation are defined in Table B.2.3.1-2, B.2.3.2-3, B.2.3.2-4 and B.2.3.2-5 as below.

The values in Table B.2.3.2-2 have been adjusted for the 4x2 and 4x4 high correlation cases to insure the correlation matrix is positive semi-definite after round-off to 4 digit precision. This is done using the equation:

$$\mathbf{R}_{high} = [\mathbf{R}_{spatial} + a\mathbf{I}_n] / (1 + a)$$

Where the value "a" is a scaling factor such that the smallest value is used to obtain a positive semi-definite result. For the 4x2 high correlation case, a=0.00010. For the 4x4 high correlation case, a=0.00012.

The same method is used to adjust the 2x4 and 4x4 medium correlation matrix in Table B.2.3.2-3 to insure the correlation matrix is positive semi-definite after round-off to 4 digit precision with a = 0.00010 and a = 0.00012.

**Table B.2.3.2-2: MIMO correlation matrices for high correlation**

<b>1x2 case</b>	$R_{high} = \begin{pmatrix} 1 & 0.9 \\ 0.9 & 1 \end{pmatrix}$
<b>2x1 case</b>	$R_{high} = \begin{pmatrix} 1 & 0.9 \\ 0.9 & 1 \end{pmatrix}$
<b>2x2 case</b>	$R_{high} = \begin{pmatrix} 1 & 0.9 & 0.9 & 0.81 \\ 0.9 & 1 & 0.81 & 0.9 \\ 0.9 & 0.81 & 1 & 0.9 \\ 0.81 & 0.9 & 0.9 & 1 \end{pmatrix}$
<b>4x2 case</b>	$R_{high} = \begin{bmatrix} 1.0000 & 0.8999 & 0.9883 & 0.8894 & 0.9542 & 0.8587 & 0.8999 & 0.8099 \\ 0.8999 & 1.0000 & 0.8894 & 0.9883 & 0.8587 & 0.9542 & 0.8099 & 0.8999 \\ 0.9883 & 0.8894 & 1.0000 & 0.8999 & 0.9883 & 0.8894 & 0.9542 & 0.8587 \\ 0.8894 & 0.9883 & 0.8999 & 1.0000 & 0.8894 & 0.9883 & 0.8587 & 0.9542 \\ 0.9542 & 0.8587 & 0.9883 & 0.8894 & 1.0000 & 0.8999 & 0.9883 & 0.8894 \\ 0.8587 & 0.9542 & 0.8894 & 0.9883 & 0.8999 & 1.0000 & 0.8894 & 0.9883 \\ 0.8999 & 0.8099 & 0.9542 & 0.8587 & 0.9883 & 0.8894 & 1.0000 & 0.8999 \\ 0.8099 & 0.8999 & 0.8587 & 0.9542 & 0.8894 & 0.9883 & 0.8999 & 1.0000 \end{bmatrix}$
<b>4x4 case</b>	$R_{high} = \begin{bmatrix} 1.0000 & 0.9882 & 0.9541 & 0.8999 & 0.9882 & 0.9767 & 0.9430 & 0.8894 & 0.9541 & 0.9430 & 0.9105 & 0.8587 & 0.8999 & 0.8894 & 0.8587 & 0.8099 \\ 0.9882 & 1.0000 & 0.9882 & 0.9541 & 0.9767 & 0.9882 & 0.9767 & 0.9430 & 0.9430 & 0.9541 & 0.9430 & 0.9105 & 0.8894 & 0.8999 & 0.8894 & 0.8587 \\ 0.9541 & 0.9882 & 1.0000 & 0.9882 & 0.9430 & 0.9767 & 0.9882 & 0.9767 & 0.9105 & 0.9430 & 0.9541 & 0.9430 & 0.8587 & 0.8894 & 0.8999 & 0.8894 \\ 0.8999 & 0.9541 & 0.9882 & 1.0000 & 0.8894 & 0.9430 & 0.9767 & 0.9882 & 0.8587 & 0.9105 & 0.9430 & 0.9541 & 0.8099 & 0.8587 & 0.8894 & 0.8999 \\ 0.9882 & 0.9767 & 0.9430 & 0.8894 & 1.0000 & 0.9882 & 0.9541 & 0.8999 & 0.9882 & 0.9767 & 0.9430 & 0.8894 & 0.9541 & 0.9430 & 0.9105 & 0.8587 \\ 0.9767 & 0.9882 & 0.9767 & 0.9430 & 0.9882 & 1.0000 & 0.9882 & 0.9541 & 0.9767 & 0.9882 & 0.9767 & 0.9430 & 0.9430 & 0.9541 & 0.9430 & 0.9105 \\ 0.9430 & 0.9767 & 0.9882 & 0.9767 & 0.9541 & 0.9882 & 1.0000 & 0.9882 & 0.9430 & 0.9767 & 0.9882 & 0.9767 & 0.9105 & 0.9430 & 0.9541 & 0.9430 \\ 0.8894 & 0.9430 & 0.9767 & 0.9882 & 0.8999 & 0.9541 & 0.9882 & 1.0000 & 0.8894 & 0.9430 & 0.9767 & 0.9882 & 0.8587 & 0.9105 & 0.9430 & 0.9541 \\ 0.9541 & 0.9430 & 0.9105 & 0.8587 & 0.9882 & 0.9767 & 0.9430 & 0.8894 & 1.0000 & 0.9882 & 0.9541 & 0.8999 & 0.9882 & 0.9767 & 0.9430 & 0.8894 \\ 0.9430 & 0.9541 & 0.9430 & 0.9105 & 0.9767 & 0.9882 & 0.9767 & 0.9430 & 0.9882 & 1.0000 & 0.9882 & 0.9541 & 0.9767 & 0.9882 & 0.9767 & 0.9430 \\ 0.9105 & 0.9430 & 0.9541 & 0.9430 & 0.9430 & 0.9767 & 0.9882 & 0.9767 & 0.9541 & 0.9882 & 1.0000 & 0.9882 & 0.9430 & 0.9767 & 0.9882 & 0.9767 \\ 0.8587 & 0.9105 & 0.9430 & 0.9541 & 0.8894 & 0.9430 & 0.9767 & 0.9882 & 0.8999 & 0.9541 & 0.9882 & 1.0000 & 0.8894 & 0.9430 & 0.9767 & 0.9882 \\ 0.8999 & 0.8894 & 0.8587 & 0.8099 & 0.9541 & 0.9430 & 0.9105 & 0.8587 & 0.9882 & 0.9767 & 0.9430 & 0.8894 & 1.0000 & 0.9882 & 0.9541 & 0.8999 \\ 0.8894 & 0.8999 & 0.8894 & 0.8587 & 0.9430 & 0.9541 & 0.9430 & 0.9105 & 0.9767 & 0.9882 & 0.9767 & 0.9430 & 0.9882 & 1.0000 & 0.9882 & 0.9541 \\ 0.8587 & 0.8894 & 0.8999 & 0.8894 & 0.9105 & 0.9430 & 0.9541 & 0.9430 & 0.9430 & 0.9767 & 0.9882 & 0.9767 & 0.9541 & 0.9882 & 1.0000 & 0.9882 \\ 0.8099 & 0.8587 & 0.8894 & 0.8999 & 0.8587 & 0.9105 & 0.9430 & 0.9541 & 0.8894 & 0.9430 & 0.9767 & 0.9882 & 0.8999 & 0.9541 & 0.9882 & 1.0000 \end{bmatrix}$





**Table B.2.3.2-4: MIMO correlation matrices for low correlation**

<b>1x2 case</b>	$R_{low} = \mathbf{I}_2$
<b>1x4 case</b>	$R_{low} = \mathbf{I}_4$
<b>2x1 case</b>	$R_{low} = \mathbf{I}_2$
<b>2x2 case</b>	$R_{low} = \mathbf{I}_4$
<b>2x4 case</b>	$R_{low} = \mathbf{I}_8$
<b>4x1 case</b>	$R_{low} = \mathbf{I}_4$
<b>4x2 case</b>	$R_{low} = \mathbf{I}_8$
<b>4x4 case</b>	$R_{low} = \mathbf{I}_{16}$

In Table B.2.3.2-4,  $\mathbf{I}_d$  is the  $d \times d$  identity matrix.

**Table B.2.3.2-5: MIMO correlation matrices for medium correlation A**

<b>2x4 case</b>	$R_{Medium A} =$	$\begin{pmatrix} 1.0000 & 0.9000 & 0.6561 & 0.3874 & 0.3000 & 0.2700 & 0.1968 & 0.1162 \\ 0.9000 & 1.0000 & 0.9000 & 0.6561 & 0.2700 & 0.3000 & 0.2700 & 0.1968 \\ 0.6561 & 0.9000 & 1.0000 & 0.9000 & 0.1968 & 0.2700 & 0.3000 & 0.2700 \\ 0.3874 & 0.6561 & 0.9000 & 1.0000 & 0.1162 & 0.1968 & 0.2700 & 0.3000 \\ 0.3000 & 0.2700 & 0.1968 & 0.1162 & 1.0000 & 0.9000 & 0.6561 & 0.3874 \\ 0.2700 & 0.3000 & 0.2700 & 0.1968 & 0.9000 & 1.0000 & 0.9000 & 0.6561 \\ 0.1968 & 0.2700 & 0.3000 & 0.2700 & 0.6561 & 0.9000 & 1.0000 & 0.9000 \\ 0.1162 & 0.1968 & 0.2700 & 0.3000 & 0.3874 & 0.6561 & 0.9000 & 1.0000 \end{pmatrix}$
<b>4x4 case</b>	$R_{medium A} =$	$\begin{pmatrix} 1.0000 & 0.9000 & 0.6561 & 0.3874 & 0.8748 & 0.7873 & 0.5739 & 0.3389 & 0.5856 & 0.5270 & 0.3842 & 0.2269 & 0.3000 & 0.2700 & 0.1968 & 0.1162 \\ 0.9000 & 1.0000 & 0.9000 & 0.6561 & 0.7873 & 0.8748 & 0.7873 & 0.5739 & 0.5270 & 0.5856 & 0.5270 & 0.3842 & 0.2700 & 0.3000 & 0.2700 & 0.1968 \\ 0.6561 & 0.9000 & 1.0000 & 0.9000 & 0.5739 & 0.7873 & 0.8748 & 0.7873 & 0.3842 & 0.5270 & 0.5856 & 0.5270 & 0.1968 & 0.2700 & 0.3000 & 0.2700 \\ 0.3874 & 0.6561 & 0.9000 & 1.0000 & 0.3389 & 0.5739 & 0.7873 & 0.8748 & 0.2269 & 0.3842 & 0.5270 & 0.5856 & 0.1162 & 0.1968 & 0.2700 & 0.3000 \\ 0.8748 & 0.7873 & 0.5739 & 0.3389 & 1.0000 & 0.9000 & 0.6561 & 0.3874 & 0.8748 & 0.7873 & 0.5739 & 0.3389 & 0.5856 & 0.5270 & 0.3842 & 0.2269 \\ 0.7873 & 0.8748 & 0.7873 & 0.5739 & 0.9000 & 1.0000 & 0.9000 & 0.6561 & 0.7873 & 0.8748 & 0.7873 & 0.5739 & 0.5270 & 0.5856 & 0.5270 & 0.3842 \\ 0.5739 & 0.7873 & 0.8748 & 0.7873 & 0.6561 & 0.9000 & 1.0000 & 0.9000 & 0.5739 & 0.7873 & 0.8748 & 0.7873 & 0.3842 & 0.5270 & 0.5856 & 0.5270 \\ 0.3389 & 0.5739 & 0.7873 & 0.8748 & 0.3874 & 0.6561 & 0.9000 & 1.0000 & 0.3389 & 0.5739 & 0.7873 & 0.8748 & 0.2269 & 0.3842 & 0.5270 & 0.5856 \\ 0.5856 & 0.5270 & 0.3842 & 0.2269 & 0.8748 & 0.7873 & 0.5739 & 0.3389 & 1.0000 & 0.9000 & 0.6561 & 0.3874 & 0.8748 & 0.7873 & 0.5739 & 0.3389 \\ 0.5270 & 0.5856 & 0.5270 & 0.3842 & 0.7873 & 0.8748 & 0.7873 & 0.5739 & 0.9000 & 1.0000 & 0.9000 & 0.6561 & 0.7873 & 0.8748 & 0.7873 & 0.5739 \\ 0.3842 & 0.5270 & 0.5856 & 0.5270 & 0.5739 & 0.7873 & 0.8748 & 0.7873 & 0.6561 & 0.9000 & 1.0000 & 0.9000 & 0.5739 & 0.7873 & 0.8748 & 0.7873 \\ 0.2269 & 0.3842 & 0.5270 & 0.5856 & 0.3389 & 0.5739 & 0.7873 & 0.8748 & 0.3874 & 0.6561 & 0.9000 & 1.0000 & 0.3389 & 0.5739 & 0.7873 & 0.8748 \\ 0.3000 & 0.2700 & 0.1968 & 0.1162 & 0.5856 & 0.5270 & 0.3842 & 0.2269 & 0.8748 & 0.7873 & 0.5739 & 0.3389 & 1.0000 & 0.9000 & 0.6561 & 0.3874 \\ 0.2700 & 0.3000 & 0.2700 & 0.1968 & 0.5270 & 0.5856 & 0.5270 & 0.3842 & 0.7873 & 0.8748 & 0.7873 & 0.5739 & 0.9000 & 1.0000 & 0.9000 & 0.6561 \\ 0.1968 & 0.2700 & 0.3000 & 0.2700 & 0.3842 & 0.5270 & 0.5856 & 0.5270 & 0.5739 & 0.7873 & 0.8748 & 0.7873 & 0.6561 & 0.9000 & 1.0000 & 0.9000 \\ 0.1162 & 0.1968 & 0.2700 & 0.3000 & 0.2269 & 0.3842 & 0.5270 & 0.5856 & 0.3389 & 0.5739 & 0.7873 & 0.8748 & 0.3874 & 0.6561 & 0.9000 & 1.0000 \end{pmatrix}$

### B.2.3A MIMO Channel Correlation Matrices using cross polarized antennas

The MIMO channel correlation matrices defined in B.2.3A apply for the antenna configuration using cross polarized (XP/X-pol) antennas at both eNodeB and UE. The cross-polarized antenna elements with +/-45 degrees polarization slant angles are deployed at eNB and cross-polarized antenna elements with +90/0 degrees polarization slant angles are deployed at UE.

For the cross-polarized antennas, the N antennas are labelled such that antennas for one polarization are listed from 1 to N/2 and antennas for the other polarization are listed from N/2+1 to N, where N is the number of transmit or receive antennas.

### B.2.3A.1 Definition of MIMO Correlation Matrices using cross polarized antennas

For the channel spatial correlation matrix, the following is used:

$$R_{spat} = P(R_{eNB} \otimes \Gamma \otimes R_{UE})P^T$$

where

- $R_{UE}$  is the spatial correlation matrix at the UE with same polarization,
- $R_{eNB}$  is the spatial correlation matrix at the eNB with same polarization,
- $\Gamma$  is a polarization correlation matrix, and
- $(\bullet)^T$  denotes transpose.

The matrix  $\Gamma$  is defined as

$$\Gamma = \begin{bmatrix} 1 & 0 & -\gamma & 0 \\ 0 & 1 & 0 & \gamma \\ -\gamma & 0 & 1 & 0 \\ 0 & \gamma & 0 & 1 \end{bmatrix}$$

A permutation matrix  $P$  elements are defined as

$$P(a,b) = \begin{cases} 1 & \text{for } a = (j-1)Nr + i \text{ and } b = 2(j-1)Nr + i, \quad i = 1, \dots, Nr, j = 1, \dots, Nt/2 \\ 1 & \text{for } a = (j-1)Nr + i \text{ and } b = 2(j - Nt/2)Nr - Nr + i, \quad i = 1, \dots, Nr, j = Nt/2 + 1, \dots, Nt \\ 0 & \text{otherwise} \end{cases}$$

where  $N_t$  and  $N_r$  is the number of transmitter and receiver respectively. This is used to map the spatial correlation coefficients in accordance with the antenna element labelling system described in B.2.3A.

### B.2.3A.2 Spatial Correlation Matrices using cross polarized antennas at eNB and UE sides

#### B.2.3A.2.1 Spatial Correlation Matrices at eNB side

For 2-antenna transmitter using one pair of cross-polarized antenna elements,  $R_{eNB} = 1$ .

For 4-antenna transmitter using two pairs of cross-polarized antenna elements,  $R_{eNB} = \begin{pmatrix} 1 & \alpha \\ \alpha^* & 1 \end{pmatrix}$ .

For 8-antenna transmitter using four pairs of cross-polarized antenna elements,  $R_{eNB} = \begin{pmatrix} 1 & \alpha^{1/9} & \alpha^{4/9} & \alpha \\ \alpha^{1/9*} & 1 & \alpha^{1/9} & \alpha^{4/9} \\ \alpha^{4/9*} & \alpha^{1/9*} & 1 & \alpha^{1/9} \\ \alpha^* & \alpha^{4/9*} & \alpha^{1/9*} & 1 \end{pmatrix}$ .

### B.2.3A.2.2 Spatial Correlation Matrices at UE side

For 2-antenna receiver using one pair of cross-polarized antenna elements,  $R_{UE} = 1$ .

For 4-antenna receiver using two pairs of cross-polarized antenna elements,  $R_{UE} = \begin{pmatrix} 1 & \beta \\ \beta^* & \mathbf{1} \end{pmatrix}$ .

### B.2.3A.3 MIMO Correlation Matrices using cross polarized antennas

The values for parameters  $\alpha$ ,  $\beta$  and  $\gamma$  for the cross polarized antenna models are given in Table B.2.3A.3-1.

**Table B.2.3A.3-1: : The  $\alpha$  and  $\beta$  parameters for cross-polarized MIMO correlation matrices**

Correlation Model	$\alpha$	$\beta$	$\gamma$
Medium Correlation A	0.3	0.6	0.2
High Correlation	0.9	0.9	0.3
Note 1:	Value of $\alpha$ applies when more than one pair of cross-polarized antenna elements at eNB side.		
Note 2:	Value of $\beta$ applies when more than one pair of cross-polarized antenna elements at UE side.		

The correlation matrices for high spatial correlation and medium correlation A are defined in Table B.2.3A.3-2 and Table B.2.3A.3-3 as below.

The values in Table B.2.3A.3-2 have been adjusted to insure the correlation matrix is positive semi-definite after round-off to 4 digit precision. This is done using the equation:

$$\mathbf{R}_{high} = [\mathbf{R}_{spat} + a\mathbf{I}_n]/(1+a)$$

Where the value “a” is a scaling factor such that the smallest value is used to obtain a positive semi-definite result. For the 8x2 high spatial correlation case, a=0.00010.

**Table B.2.3A.3-2: MIMO correlation matrices for high spatial correlation**

<b>4x2 case</b>	$R_{high} =$	1.0000 0.0000 0.9000 0.0000 -0.3000 0.0000 -0.2700 0.0000
		0.0000 1.0000 0.0000 0.9000 0.0000 0.3000 0.0000 0.2700
		0.9000 0.0000 1.0000 0.0000 -0.2700 0.0000 -0.3000 0.0000
		0.0000 0.9000 0.0000 1.0000 0.0000 0.2700 0.0000 0.3000
		-0.3000 0.0000 -0.2700 0.0000 1.0000 0.0000 0.9000 0.0000
		0.0000 0.3000 0.0000 0.2700 0.0000 1.0000 0.0000 0.9000
		-0.2700 0.0000 -0.3000 0.0000 0.9000 0.0000 1.0000 0.0000
		0.0000 0.2700 0.0000 0.3000 0.0000 0.9000 0.0000 1.0000
<b>8x2 case</b>	$R_{high} =$	1.0000 0.0000 0.9883 0.0000 0.9542 0.0000 0.8999 0.0000 -0.3000 0.0000 -0.2965 0.0000 -0.2862 0.0000 -0.2700 0.0000
		0.0000 1.0000 0.0000 0.9883 0.0000 0.9542 0.0000 0.8999 0.0000 0.3000 0.0000 0.2965 0.0000 0.2862 0.0000 0.2700
		0.9883 0.0000 1.0000 0.0000 0.9883 0.0000 0.9542 0.0000 -0.2965 0.0000 -0.3000 0.0000 -0.2965 0.0000 -0.2862 0.0000
		0.0000 0.9883 0.0000 1.0000 0.0000 0.9883 0.0000 0.9542 0.0000 0.2965 0.0000 0.3000 0.0000 0.2965 0.0000 0.2862
		0.9542 0.0000 0.9883 0.0000 1.0000 0.0000 0.9883 0.0000 -0.2862 0.0000 -0.2965 0.0000 -0.3000 0.0000 -0.2965 0.0000
		0.0000 0.9542 0.0000 0.9883 0.0000 1.0000 0.0000 0.9883 0.0000 0.2862 0.0000 0.2965 0.0000 0.3000 0.0000 0.2965
		0.8999 0.0000 0.9542 0.0000 0.9883 0.0000 1.0000 0.0000 -0.2700 0.0000 -0.2862 0.0000 -0.2965 0.0000 -0.3000 0.0000
		0.0000 0.8999 0.0000 0.9542 0.0000 0.9883 0.0000 1.0000 0.0000 0.2700 0.0000 0.2862 0.0000 0.2965 0.0000 0.3000
		-0.3000 0.0000 -0.2965 0.0000 -0.2862 0.0000 -0.2700 0.0000 1.0000 0.0000 0.9883 0.0000 0.9542 0.0000 0.8999 0.0000
		0.0000 0.3000 0.0000 0.2965 0.0000 0.2862 0.0000 0.2700 0.0000 1.0000 0.0000 0.9883 0.0000 0.9542 0.0000 0.8999
		-0.2965 0.0000 -0.3000 0.0000 -0.2965 0.0000 -0.2862 0.0000 0.9883 0.0000 1.0000 0.0000 0.9883 0.0000 0.9542 0.0000
		0.0000 0.2965 0.0000 0.3000 0.0000 0.2965 0.0000 0.2862 0.0000 0.9883 0.0000 1.0000 0.0000 0.9883 0.0000 0.9542
		-0.2862 0.0000 -0.2965 0.0000 -0.3000 0.0000 -0.2965 0.0000 0.9542 0.0000 0.9883 0.0000 1.0000 0.0000 0.9883 0.0000
		0.0000 0.2862 0.0000 0.2965 0.0000 0.3000 0.0000 0.2965 0.0000 0.9542 0.0000 0.9883 0.0000 1.0000 0.0000 0.9883
		-0.2700 0.0000 -0.2862 0.0000 -0.2965 0.0000 -0.3000 0.0000 0.8999 0.0000 0.9542 0.0000 0.9883 0.0000 1.0000 0.0000
		0.0000 0.2700 0.0000 0.2862 0.0000 0.2965 0.0000 0.3000 0.0000 0.8999 0.0000 0.9542 0.0000 0.9883 0.0000 1.0000

**Table B.2.3A.3-3: MIMO correlation matrices for medium correlation A**

<b>4x4</b>	$R_{Medium A} =$	$\begin{pmatrix} 1.0000 & 0.6000 & 0.0000 & 0.0000 & 0.3000 & 0.1800 & 0.0000 & 0.0000 & -0.2000 & -0.1200 & 0.0000 & 0.0000 & -0.0600 & -0.0360 & 0.0000 & 0.0000 \\ 0.6000 & 1.0000 & 0.0000 & 0.0000 & 0.1800 & 0.3000 & 0.0000 & 0.0000 & -0.1200 & -0.2000 & 0.0000 & 0.0000 & -0.0360 & -0.0600 & 0.0000 & 0.0000 \\ 0.0000 & 0.0000 & 1.0000 & 0.6000 & 0.0000 & 0.0000 & 0.3000 & 0.1800 & 0.0000 & 0.0000 & 0.2000 & 0.1200 & 0.0000 & 0.0000 & 0.0600 & 0.0360 \\ 0.0000 & 0.0000 & 0.6000 & 1.0000 & 0.0000 & 0.0000 & 0.1800 & 0.3000 & 0.0000 & 0.0000 & 0.1200 & 0.2000 & 0.0000 & 0.0000 & 0.0360 & 0.0600 \\ 0.3000 & 0.1800 & 0.0000 & 0.0000 & 1.0000 & 0.6000 & 0.0000 & 0.0000 & -0.0600 & -0.0360 & 0.0000 & 0.0000 & -0.2000 & -0.1200 & 0.0000 & 0.0000 \\ 0.1800 & 0.3000 & 0.0000 & 0.0000 & 0.6000 & 1.0000 & 0.0000 & 0.0000 & -0.0360 & -0.0600 & 0.0000 & 0.0000 & -0.1200 & -0.2000 & 0.0000 & 0.0000 \\ 0.0000 & 0.0000 & 0.3000 & 0.1800 & 0.0000 & 0.0000 & 1.0000 & 0.6000 & 0.0000 & 0.0000 & 0.0600 & 0.0360 & 0.0000 & 0.0000 & 0.2000 & 0.1200 \\ 0.0000 & 0.0000 & 0.1800 & 0.3000 & 0.0000 & 0.0000 & 0.6000 & 1.0000 & 0.0000 & 0.0000 & 0.0360 & 0.0600 & 0.0000 & 0.0000 & 0.1200 & 0.2000 \\ -0.2000 & -0.1200 & 0.0000 & 0.0000 & -0.0600 & -0.0360 & 0.0000 & 0.0000 & 1.0000 & 0.6000 & 0.0000 & 0.0000 & 0.3000 & 0.1800 & 0.0000 & 0.0000 \\ -0.1200 & -0.2000 & 0.0000 & 0.0000 & -0.0360 & -0.0600 & 0.0000 & 0.0000 & 0.6000 & 1.0000 & 0.0000 & 0.0000 & 0.1800 & 0.3000 & 0.0000 & 0.0000 \\ 0.0000 & 0.0000 & 0.2000 & 0.1200 & 0.0000 & 0.0000 & 0.0600 & 0.0360 & 0.0000 & 0.0000 & 1.0000 & 0.6000 & 0.0000 & 0.0000 & 0.3000 & 0.1800 \\ 0.0000 & 0.0000 & 0.1200 & 0.2000 & 0.0000 & 0.0000 & 0.0360 & 0.0600 & 0.0000 & 0.0000 & 0.6000 & 1.0000 & 0.0000 & 0.0000 & 0.1800 & 0.3000 \\ -0.0600 & -0.0360 & 0.0000 & 0.0000 & -0.2000 & -0.1200 & 0.0000 & 0.0000 & 0.3000 & 0.1800 & 0.0000 & 0.0000 & 1.0000 & 0.6000 & 0.0000 & 0.0000 \\ -0.0360 & -0.0600 & 0.0000 & 0.0000 & -0.1200 & -0.2000 & 0.0000 & 0.0000 & 0.1800 & 0.3000 & 0.0000 & 0.0000 & 0.6000 & 1.0000 & 0.0000 & 0.0000 \\ 0.0000 & 0.0000 & 0.0600 & 0.0360 & 0.0000 & 0.0000 & 0.2000 & 0.1200 & 0.0000 & 0.0000 & 0.3000 & 0.1800 & 0.0000 & 0.0000 & 1.0000 & 0.6000 \\ 0.0000 & 0.0000 & 0.0360 & 0.0600 & 0.0000 & 0.0000 & 0.1200 & 0.2000 & 0.0000 & 0.0000 & 0.1800 & 0.3000 & 0.0000 & 0.0000 & 0.6000 & 1.0000 \end{pmatrix}$
------------	------------------	--

### B.2.3A.4 Beam steering approach

Given the channel spatial correlation matrix in B.2.3A.1, the corresponding random channel matrix  $H$  can be calculated. The signal model for the  $k$ -th subframe is denoted as

$$y = HD_{\theta_k}Wx + n$$

Where

- $H$  is the  $N_r \times N_t$  channel matrix per subcarrier.
- $D_{\theta_k}$  is the steering matrix,

$$\text{For 8 transmission antennas, } D_{\theta_k} = \begin{bmatrix} 1 & 0 \\ 0 & 1 \end{bmatrix} \otimes \begin{bmatrix} 1 & 0 & 0 & 0 \\ 0 & e^{j\theta_k} & 0 & 0 \\ 0 & 0 & e^{j2\theta_k} & 0 \\ 0 & 0 & 0 & e^{j3\theta_k} \end{bmatrix};$$

$$\text{For 4 transmission antennas, } D_{\theta_k} = \begin{bmatrix} 1 & 0 \\ 0 & 1 \end{bmatrix} \otimes \begin{bmatrix} 1 & 0 \\ 0 & e^{j3\theta_k} \end{bmatrix}.$$

- $\theta_k$  controls the phase variation, and the phase for  $k$ -th subframe is denoted by  $\theta_k = \theta_0 + \Delta\theta \cdot k$ , where  $\theta_0$  is the random start value with the uniform distribution, i.e.,  $\theta_0 \in [0, 2\pi]$ ,  $\Delta\theta$  is the step of phase variation, which is defined in Table B.2.3A.4-1, and  $k$  is the linear increment of 1 for every subframe throughout the simulation,
- $W$  is the precoding matrix for  $N_t$  transmission antennas,
- $y$  is the received signal,  $x$  is the transmitted signal, and  $n$  is AWGN.

**Table B.2.3A.4-1: The step of phase variation**

Variation Step	Value (rad/subframe)
$\Delta\theta$	$1.2566 \times 10^{-3}$

### B.2.3B MIMO Channel Correlation Matrices using two-dimension cross polarized antennas at eNB and cross polarized antennas at UE

The MIMO channel correlation matrices defined in B.2.3B apply for the antenna configuration using two-dimension (2D) cross polarized antennas at eNodeB and the antenna configuration using cross polarized antennas at UE. The cross-polarized antenna elements with  $\pm 45$  degrees polarization slant angles are deployed at eNB and cross-polarized antenna elements with  $+90/0$  degrees polarization slant angles are deployed at UE.

For 2D cross-polarized antenna array at eNodeB, the  $N$  antennas are indexed by  $(N_1, N_2, P)$ , and total number of antennas is  $N = P \cdot N_1 \cdot N_2$ , where

- $N_1$  is the number of antenna elements in first dimension (i.e. vertical direction) with same polarization,
- $N_2$  is the number of antenna elements in second dimension (i.e. horizontal direction) with same polarization, and
- $P$  is the number of polarization groups.

For the 2D cross-polarized antennas at eNB, the  $N$  antennas are labelled such that antennas shall be in increasing order of the second dimension firstly, then the first dimension, and finally the polarization group. For a specific antenna

element at  $p$ -th polarization,  $n_1$ -th row, and  $n_2$ -th column within the 2D antenna array, the following index number is used for antenna labelling:

$$\text{Index}(p, n_1, n_2) = p \cdot N_1 \cdot N_2 + n_1 \cdot N_2 + n_2 + 1, \quad p = 0, 1, \quad n_1 = 0, \dots, N_1 - 1, \quad n_2 = 0, \dots, N_2 - 1.$$

where  $N$  is the number of transmit antennas,  $p$  is the polarization group index,  $n_1$  is the row index, and  $n_2$  is the column index of the antenna element.

For the cross-polarized antennas at UE, the  $N$  antennas are labelled such that antennas for one polarization are listed from 1 to  $N/2$  and antennas for the other polarization are listed from  $N/2+1$  to  $N$ , where  $N$  is the number of receive antennas.

### B.2.3B.1 Definition of MIMO Correlation Matrices using two-dimension cross polarized antennas at eNB and cross polarized antennas at UE

For the channel spatial correlation matrix, the following is used:

$$R_{\text{spat}} = P(R_{\text{eNB}} \otimes \Gamma \otimes R_{\text{UE}})P^T$$

where

- $R_{\text{UE}}$  is the spatial correlation matrix at the UE with same polarization,
- $R_{\text{eNB}}$  is the spatial correlation matrix at the eNB with same polarization,
- $\Gamma$  is a polarization correlation matrix, and
- $(\bullet)^T$  denotes transpose.

The spatial correlation matrix at the eNB is further expressed as following:

$$R_{\text{eNB}} = R_{\text{eNB\_Dim,1}} \otimes R_{\text{eNB\_Dim,2}}$$

where

- $R_{\text{eNB\_Dim,1}}$  is the correlation matrix of antenna elements in first dimension with same polarization, and
- $R_{\text{eNB\_Dim,2}}$  is the correlation matrix of antenna elements in second dimension with same polarization.

The matrix  $\Gamma$  is defined as

$$\Gamma = \begin{bmatrix} 1 & 0 & -\gamma & 0 \\ 0 & 1 & 0 & \gamma \\ -\gamma & 0 & 1 & 0 \\ 0 & \gamma & 0 & 1 \end{bmatrix}$$

A permutation matrix  $P$  elements are defined as

$$P(a, b) = \begin{cases} 1 & \text{for } a = (j-1)Nr + i \text{ and } b = 2(j-1)Nr + i, \quad i = 1, \dots, Nr, j = 1, \dots, Nt/2 \\ 1 & \text{for } a = (j-1)Nr + i \text{ and } b = 2(j - Nt/2)Nr - Nr + i, \quad i = 1, \dots, Nr, j = Nt/2 + 1, \dots, Nt \\ 0 & \text{otherwise} \end{cases}$$

where  $N_t$  and  $N_r$  is the number of transmitter and receiver respectively. This is used to map the spatial correlation coefficients in accordance with the antenna element labelling system described in B.2.3B.

## B.2.3B.2 Spatial Correlation Matrices using two-dimension cross polarized antennas at eNB and cross polarized antennas at UE

### B.2.3B.2.1 Spatial Correlation Matrices at eNB side

For one direction of the 2D antenna array at the eNB side, the followings are used to construct the spatial correlation matrix:

For 1 antenna element of the same polarization in one direction,  $R_{eNB\_Dimj} = 1$ .

For 2 antenna elements of the same polarization in one direction,  $R_{eNB\_Dimj} = \begin{pmatrix} 1 & \alpha_i \\ \alpha_i^* & 1 \end{pmatrix}$ .

For 3 antenna elements of the same polarization in one direction,  $R_{eNB\_Dimj} = \begin{pmatrix} 1 & \alpha_i^{1/4} & \alpha_i \\ \alpha_i^{1/4} & 1 & \alpha_i^{1/4} \\ \alpha_i^* & \alpha_i^{1/4} & 1 \end{pmatrix}$ .

For 4 antenna elements of the same polarization in one direction,  $R_{eNB\_Dimj} = \begin{pmatrix} 1 & \alpha_i^{1/6} & \alpha_i^{1/9} & \alpha_i \\ \alpha_i^{1/6} & 1 & \alpha_i^{1/6} & \alpha_i^{1/6} \\ \alpha_i^{1/6} & \alpha_i^{1/6} & 1 & \alpha_i^{1/6} \\ \alpha_i^* & \alpha_i^{1/6} & \alpha_i^{1/9} & 1 \end{pmatrix}$ .

where the index  $i=1,2$  stands for first dimension and second dimension respectively.

### B.2.3B.2.2 Spatial Correlation Matrices at UE side

For 2-antenna receiver using one pair of cross-polarized antenna elements,  $R_{UE} = 1$ .

For 4-antenna receiver using two pairs of cross-polarized antenna elements,  $R_{UE} = \begin{pmatrix} 1 & \beta \\ \beta^* & 1 \end{pmatrix}$ .

## B.2.3B.3 MIMO Correlation Matrices using two-dimension cross polarized antennas at eNB and cross polarized antennas at UE

The values for parameters  $\alpha_1, \alpha_2, \beta$  and  $\gamma$  for high and medium spatial correlation are given in Table B.2.3B.3-1.

**Table B.2.3B.3-1**

Correlation type	$\alpha_1$	$\alpha_2$	$\beta$	$\gamma$
High	0.9	0.9	0.9	0.3
Medium	0.3	0.3	0.6	0.2
Note 1:	Value of $\alpha_1$ applies when more than one pair of cross-polarized antenna elements in first dimension at eNB side.			
Note 2:	Value of $\alpha_2$ applies when more than one pair of cross-polarized antenna elements in second dimension at eNB side.			
Note 3:	Value of $\beta$ applies when more than one pair of cross-polarized antenna elements at UE side.			

The correlation matrices for high spatial correlation with 12(2,3,2)x2 case and 16(2,4,2)x2 case are defined in Table B.2.3B.3-2 as below.

The values in Table B.2.3B.3-2 have been adjusted to insure the correlation matrix is positive semi-definite after round-off to 4 digit precision. This is done using the equation:



$$\mathbf{R}_{high} = [\mathbf{R}_{spat} + a\mathbf{I}_n] / (1 + a)$$

where the value "a" is a scaling factor such that the smallest value is used to obtain a positive semi-definite result. For the 16(2,4,2)x2 high spatial correlation case, a=0.00012.

The same method is used to adjust the the 24(3,4,2)x2 and 32(4,4,2)x2 high correlation matrix to insure the correlation matrix is positive semi-definite after round-off to 4 digit precision with a =0.00012 and a=0.00022.



### B.2.3B.4 Beam steering approach

Given the channel spatial correlation matrix in B.2.3B.1, the corresponding random channel matrix  $H$  can be calculated. The signal model for the  $k$ -th subframe is denoted as

$$y = HD_{\theta_{k,1},\theta_{k,2}}Wx+n$$

And the steering matrix is further expressed as following:

$$D_{\theta_{k,1},\theta_{k,2}} = \begin{bmatrix} 1 & 0 \\ 0 & 1 \end{bmatrix} \otimes (D_{\theta_{k,1}}(N_1) \otimes D_{\theta_{k,2}}(N_2))$$

where

- $H$  is the  $N_r \times N_t$  channel matrix per subcarrier.
- $D_{\theta_{k,1},\theta_{k,2}}$  is the steering matrix,
- $D_{\theta_{k,1}}(N_1)$  is the steering matrix in first dimension with same polarization,
- $D_{\theta_{k,2}}(N_2)$  is the steering matrix in second dimension with same polarization,
- $N_1$  is the number of antenna elements in first dimension with same polarization,
- $N_2$  is the number of antenna elements in second dimension with same polarization,

For 1 antenna element of the same polarization in one direction,  $D_{\theta_{k,i}}(1) = 1$ .

For 2 antenna elements of the same polarization in one direction,  $D_{\theta_{k,i}}(2) = \begin{bmatrix} 1 & 0 \\ 0 & e^{j3\theta_{k,i}} \end{bmatrix}$ .

For 3 antenna elements of the same polarization in one direction,  $D_{\theta_{k,i}}(3) = \begin{bmatrix} 1 & 0 & 0 \\ 0 & e^{j1.5\theta_{k,i}} & 0 \\ 0 & 0 & e^{j3\theta_{k,i}} \end{bmatrix}$ .

For 4 antenna elements of the same polarization in one direction,  $D_{\theta_{k,i}}(4) = \begin{bmatrix} 1 & 0 & 0 & 0 \\ 0 & e^{j\theta_{k,i}} & 0 & 0 \\ 0 & 0 & e^{j2\theta_{k,i}} & 0 \\ 0 & 0 & 0 & e^{j3\theta_{k,i}} \end{bmatrix}$ .

where the index  $i=1,2$  stands for first dimension and second dimension respectively.

- $\theta_{k,i}$  controls the phase variation in first dimension and second dimension respectively, and the phase for  $k$ -th subframe is denoted by  $\theta_{k,i} = \theta_{0,i} + \Delta\theta \cdot k$ , where  $\theta_{0,i}$  is the random start value with the uniform distribution, i.e.,  $\theta_{0,i} \in [0, 2\pi]$ ,  $\Delta\theta$  is the step of phase variation, which is defined in Table B.2.3B.4-1, and  $k$  is the linear increment of 1 for every subframe throughout the simulation, the index  $i=1,2$  stands for first dimension and second dimension respectively.
- $W$  is the precoding matrix for  $N_t$  transmission antennas,
- $y$  is the received signal,  $x$  is the transmitted signal, and  $n$  is AWGN.

**Table B.2.3B.4-1: The step of phase variation**

Variation Step	Value (rad/subframe)
$\Delta\theta$	$1.2566 \times 10^{-3}$

### B.2.3B.4A Beam steering approach with dual cluster beams

Given the channel spatial correlation matrix in B.2.3B.1, the corresponding random channel matrix  $H$  can be calculated. The signal model for the  $k$ -th subframe is denoted as

$$y = \left[ \sqrt{\frac{1}{1+p^2}} H_m D_{\theta_{k,1}, \theta_{k,2}}^{(m)} + \sqrt{\frac{p^2}{1+p^2}} H_s D_{\theta_{k,1}, \theta_{k,2}}^{(s)} \right] W X +$$

And the steering matrix is further expressed as following:

$$D_{\theta_{k,1}, \theta_{k,2}} = \begin{bmatrix} 1 & 0 \\ 0 & 1 \end{bmatrix} \otimes (D_{\theta_{k,1}}(N_1) \otimes D_{\theta_{k,2}}(N_2))$$

where

- $m, s$  are independent channels for the first beam and second beam with the  $N_r \times N_t$  channel matrix per subcarrier.
- $\theta_{k,1}, \theta_{k,2}^{(m)}, \theta_{k,1}, \theta_{k,2}^{(s)}$  are the steering matrix for first beam and second beam
- $D_{\theta_{k,1}}(N_1)$  is the steering matrix in first dimension with same polarization,
- $D_{\theta_{k,2}}(N_2)$  is the steering matrix in second dimension with same polarization,
- $N_1$  is the number of antenna elements in first dimension with same polarization,
- $N_2$  is the number of antenna elements in second dimension with same polarization,
- $p$  is the relative power ratio of the second beam to the first beam, the value of  $p$  is specific to a test case,

For 1 antenna element of the same polarization in one direction,  $D_{\theta_{k,j}}(1) = 1$ .

For 2 antenna elements of the same polarization in one direction,  $D_{\theta_{k,j}}(2) = \begin{bmatrix} 1 & 0 \\ 0 & e^{j3\theta_{k,j}} \end{bmatrix}$ .

For 3 antenna elements of the same polarization in one direction,  $D_{\theta_{k,j}}(3) = \begin{bmatrix} 1 & 0 & 0 \\ 0 & e^{j1.5\theta_{k,j}} & 0 \\ 0 & 0 & e^{j3\theta_{k,j}} \end{bmatrix}$ .

For 4 antenna elements of the same polarization in one direction,  $D_{\theta_{k,j}}(4) = \begin{bmatrix} 1 & 0 & 0 & 0 \\ 0 & e^{j\theta_{k,j}} & 0 & 0 \\ 0 & 0 & e^{j2\theta_{k,j}} & 0 \\ 0 & 0 & 0 & e^{j3\theta_{k,j}} \end{bmatrix}$ .

where the index  $i = 1, 2$  stands for first dimension and second dimension respectively.

- $\theta_{k,j}$  controls the phase variation in first dimension and second dimension respectively, and the phase for  $k$ -th subframe is denoted by  $\theta_{k,j} = \theta_{0,j} + \Delta\theta \cdot k$ , where  $\theta_{0,j}$  is the random start value with the uniform distribution,

i.e.,  $\theta_{0,i} \in [0, 2\pi]$ ,  $\Delta\theta$  is the step of phase variation, which is defined in Table B.2.3B.4-1, and  $k$  is the linear increment of 1 for every subframe throughout the simulation, the index  $i = 1, 2$  stands for first dimension and second dimension respectively.

- $W$  is the precoding matrix for  $N_t$  transmission antennas,
- $y$  is the received signal,  $x$  is the transmitted signal, and  $n$  is AWGN.

**Table B.2.3B.4A-1: The step of phase variation**

Variation Step	Value (rad/subframe)
$\Delta\theta^{(i)}$	$1.2566 \times 10^{-3}$
$\Delta\theta^{(j)}$	$2.5132 \times 10^{-3}$

## B.2.4 Propagation conditions for CQI tests

For Channel Quality Indication (CQI) tests, the following additional multi-path profile is used:

$$h(t, \tau) = \delta(\tau) + a \exp(-i2\pi f_D t) \delta(\tau - \tau_d),$$

in continuous time  $(t, \tau)$  representation, with  $\tau_d$  the delay,  $a$  a constant and  $f_D$  the Doppler frequency. The same  $h(t, \tau)$  is used to describe the fading channel between every pair of Tx and Rx.

### B.2.4.1 Propagation conditions for CQI tests with multiple CSI processes

For CQI tests with multiple CSI processes, the following additional multi-path profile is used for 2 port transmission:

$$H = \begin{bmatrix} 1 & j \\ 1 & -j \end{bmatrix} \circ H_{MP}$$

Where  $\circ$  represents Hadamard product,  $H_{MP}$  indicates the 2x2 propagation channel generated in the manner defined in Clause B.2.4.

## B.2.5 Void

## B.2.6 MBSFN Propagation Channel Profile

### B.2.6.1 Subcarrier spacing 15kHz or 7.5kHz

Table B.2.6.1-1 shows propagation conditions that are used for the MBSFN performance requirements in multi-path fading environment in an extended delay spread environment.

**Table B.2.6.1-1: Propagation Conditions for Multi-Path Fading Environments for MBSFN Performance Requirements in an extended delay spread environment with subcarrier spacing 15kHz or 7.5kHz**

Extended Delay Spread	
Maximum Doppler frequency [5Hz]	
Relative Delay [ns]	Relative Mean Power [dB]
0	0
30	-1.5
150	-1.4
310	-3.6
370	-0.6
1090	-7.0
12490	-10
12520	-11.5
12640	-11.4
12800	-13.6
12860	-10.6
13580	-17.0
27490	-20
27520	-21.5
27640	-21.4
27800	-23.6
27860	-20.6
28580	-27.0

### B.2.6.2 Subcarrier spacing 1.25kHz

Table B.2.6.2-1 shows propagation conditions that are used for the MBSFN performance requirements in multi-path fading environment in an extended delay spread environment for subcarrier spacing as 1.25kHz.

**Table B.2.6.2-1: Propagation Conditions for Multi-Path Fading Environments for MBSFN Performance Requirements in an extended delay spread environment with subcarrier spacing 1.25kHz**

Extended Delay Spread	
Maximum Doppler frequency [5Hz]	
Relative Delay [ns]	Relative Mean Power [dB]
0	0
30	-1.5
150	-1.4
310	-3.6
370	-0.6
1090	-7.0
49960	-10
49990	-11.5
50110	-11.4
50270	-13.6
50330	-10.6
51050	-17.0
109960	-20
109990	-21.5
110110	-21.4
110270	-23.6
110330	-20.6
111050	-27.0

### B.2.6.3 Subcarrier spacing 0.37kHz

Table B.2.6.3-1 shows propagation conditions that are used for the MBSFN performance requirements in multi-path fading environment in an extended delay spread environment for subcarrier spacing as 0.37kHz.

**Table B.2.6.3-1: Propagation Conditions for Multi-Path Fading Environments for MBSFN Performance Requirements in an extended delay spread environment with subcarrier spacing 0.37kHz**

Extended Delay Spread	
Zero Doppler frequency	
Relative Delay [ $\mu$ s]	Relative Mean Power [dB]
0	-11
130	-10
220	-4.5
240	-3.5
400	0
520	-13
650	-20
800	-25

### B.2.6.4 Subcarrier spacing 2.5kHz

Table B.2.6.4-1 shows propagation conditions that are used for the MBSFN performance requirements in multi-path fading environment in an extended delay spread environment for subcarrier spacing as 2.5kHz.

**Table B.2.6.4-1: Propagation Conditions for Multi-Path Fading Environments for MBSFN Performance Requirements in an extended delay spread environment with subcarrier spacing 2.5kHz**

Extended Delay Spread	
Maximum Doppler frequency [162Hz]	
Relative Delay [ns]	Relative Mean Power [dB]
-310	-3.6
-280	-1.5
-160	-1.4
0	0
60	-0.6
780	-7.0
49650	-10
49680	-11.5
49800	-11.4
49960	-13.6
50020	-10.6
50740	-17.0
109650	-20
109680	-21.5
109800	-21.4
109960	-23.6
110020	-20.6
110740	-27.0

### B.3 High speed train scenario

The high speed train condition for the test of the baseband performance is a non fading propagation channel with one tap. Doppler shift is given by

$$f_s(t) = f_d \cos \theta(t) \quad (\text{B.3.1})$$

where  $f_s(t)$  is the Doppler shift and  $f_d$  is the maximum Doppler frequency. The cosine of angle  $\theta(t)$  is given by

$$\cos \theta(t) = \frac{D_s/2 - vt}{\sqrt{D_{\min}^2 + (D_s/2 - vt)^2}}, \quad 0 \leq t \leq D_s/v \quad (\text{B.3.2})$$

$$\cos \theta(t) = \frac{-1.5D_s + vt}{\sqrt{D_{\min}^2 + (-1.5D_s + vt)^2}}, \quad D_s/v < t \leq 2D_s/v \quad (\text{B.3.3})$$

$$\cos \theta(t) = \cos \theta(t \bmod (2D_s/v)), \quad t > 2D_s/v \quad (\text{B.3.4})$$

where  $D_s/2$  is the initial distance of the train from eNodeB, and  $D_{\min}$  is eNodeB Railway track distance, both in meters;  $v$  is the velocity of the train in m/s,  $t$  is time in seconds.



Doppler shift and cosine angle are given by equation B.3.1 and B.3.2-B.3.4 respectively, where the required input parameters listed in table B.3-1 and the resulting Doppler shift shown in Figure B.3-1 are applied for all frequency bands.

**Table B.3-1: High speed train scenario**

Parameter	Value
$D_s$	300 m
$D_{\min}$	2 m
$v$	300 km/h
$f_d$	750 Hz

NOTE 1: Parameters for HST conditions in table B.3-1 including  $f_d$  and Doppler shift trajectories presented on figure B.3-1 were derived from Band 7 and are applied for performance verification in all frequency bands.

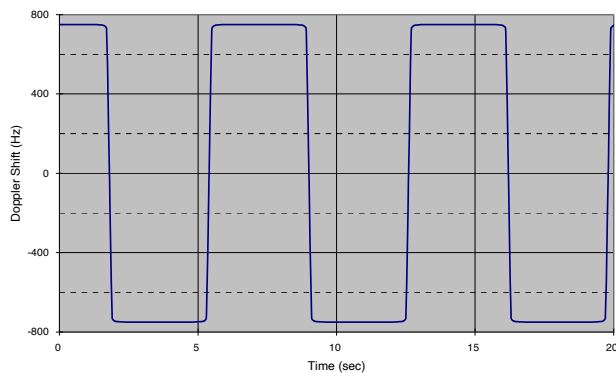

**Figure B.3-1: Doppler shift trajectory**

For 1x2 antenna configuration, the same  $h(t,\tau)$  is used to describe the channel between every pair of Tx and Rx.

For 2x2 antenna configuration, the same  $h(t,\tau)$  is used to describe the channel between every pair of Tx and Rx with

phase shift according to  $\mathbf{H} = \begin{pmatrix} 1 & j \\ 1 & -j \end{pmatrix}$ .

## B.3A HST-SFN scenario

There is an infinite number of RRHs distributed equidistantly along the track with the same Cell ID as depicted in figure B.3A-1.

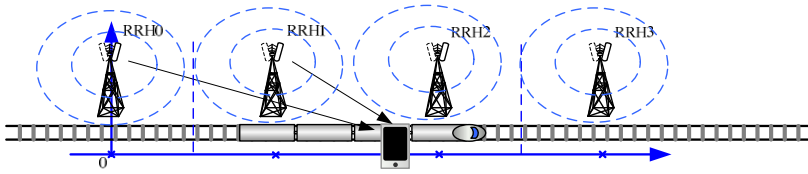

Figure B.3A-1: Deployment of HST-SFN

The location of RRH  $k$  is given as:

$$x_k = k * D_s + j * D_{\min} \quad (\text{B.3A.1})$$

where:  $k \in [-\infty, \infty]$ ,  $j = \text{sqrt}(-1)$  and  $D_{\min}$  is the distance between the RRHs and railway track, while  $D_s$  is the distance of two RRHs, both in meters.

The train location is denoted as:

$$y = a + j * 0 \quad (\text{B.3A.2})$$

where:  $a \in [0, \infty]$  and  $a$  means distance in meters, which means the train is right on the track.

The HST-SFN scenario for the test of the baseband performance is a non fading propagation channel with four taps, namely the four nearest RRHs. Thus RRH  $k$  is visible for the train only in the range:

$$k * D_s - 2 * D_s \leq a < k * D_s + 2 * D_s \quad (\text{B.3A.3})$$

Power level  $P_k$  (dB) for the signal from  $k$ th RRH, normalized to the total power received from all visible RRHs, is given by:

$$P_k = -20 \lg(|y - x_k|) - 10 \lg \left( \frac{1}{\sum_{i \in \{k-2, k-1, k, k+1, k+2\}} \frac{1}{|y - x_i|^2}} \right) \quad \text{for } k * D_s - 2 * D_s \leq a < k * D_s + 2 * D_s \quad (\text{B.3A.4})$$

Doppler shift  $F_{D,k}$  (Hz) from  $k$ th RRH is given by:

$$F_{D,k} = f_c \times \text{real} \left[ -v \times \frac{y - x_k}{|y - x_k| \times C} \right] \quad \text{for } k * D_s - 2 * D_s \leq a < k * D_s + 2 * D_s \quad (\text{B.3A.5})$$

The relative delay  $T_k$  (s) for the signal from  $k$ th RRH can be derived as:

$$T_k = \frac{|y - x_k|}{C} \quad \text{for } k * D_s - 2 * D_s \leq a < k * D_s + 2 * D_s \quad (\text{B.3A.6})$$

In the above  $v$  (m/s) is the moving speed of the train,  $f_c$  (Hz) is the center frequency, and  $C$  (m/s) is the velocity of light.

Power level, Doppler shift and relative delay are given by equations B.3A.4 ~ B.3A.6 respectively, where the required input parameters listed in table B.3A-1 and the resulting Doppler shift shown in Figure B.3A-3 are applied for all frequency bands.

**Table B.3A-1: HST-SFN scenario**

Parameter	Value
$D_s$	1000 m
$D_{\min}$	50m
$v$	350 km/h
$f_d$	872 Hz

NOTE 1: Parameters for HST-SFN scenario in Table B.3A-1 including  $f_d$  and Doppler shift trajectories presented in Figure B.3A-2 were derived from Band 7 and are applied for performance verification in all frequency bands. And the trajectories of relative power, Doppler shifts and relative delay presented in Figures B.3A-2~ B.3A-4 are derived from the equations B.3A.4 ~ B.3A.6 respectively.

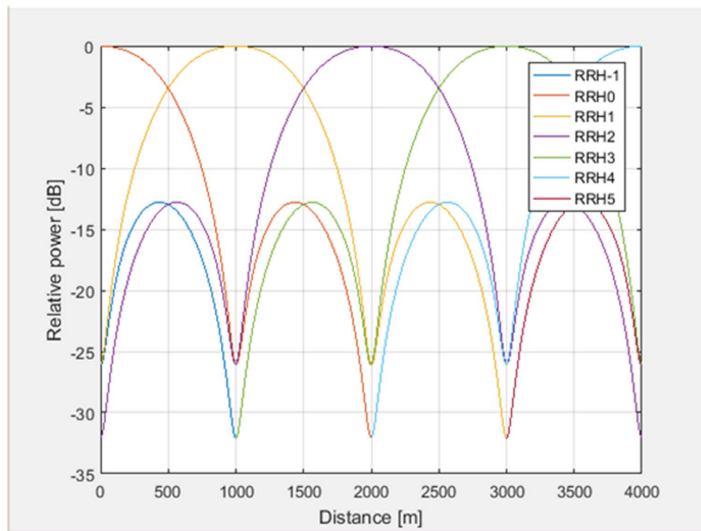
**Figure B.3A-2 Relative power level trajectories**

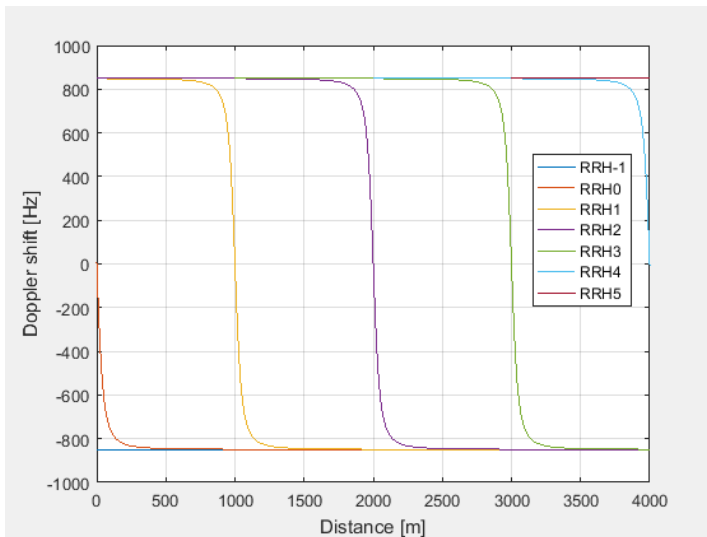

Figure B.3A-3 Doppler shifts trajectories

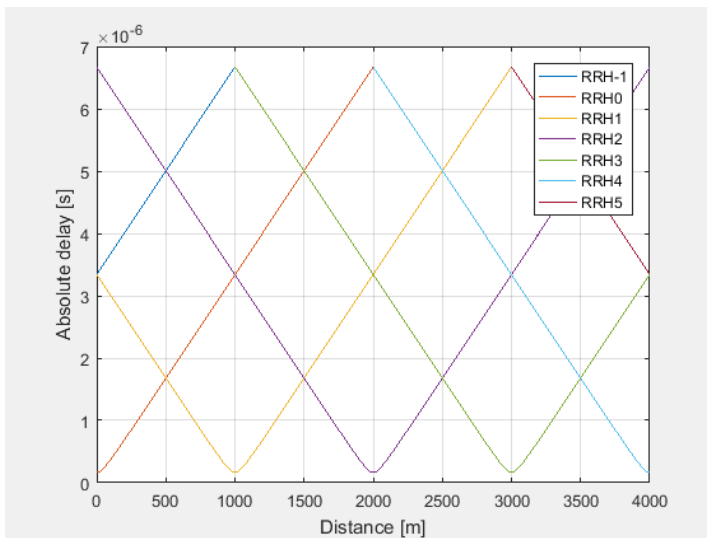

Figure B.3A-4 Relative delay trajectories

For 2x2 antenna configuration, the same  $h(t,\tau)$  is used to describe the channel between every pair of Tx and Rx with phase shift according to  $\mathbf{H} = \begin{pmatrix} 1 & j \\ 1 & -j \end{pmatrix}$ .

For 2x4 antenna configuration, the same  $h(t,\tau)$  is used to describe the channel between every pair of Tx and Rx with

$$\mathbf{H} = \begin{bmatrix} 1 & j \\ 1 & -j \\ 1 & j \\ 1 & -j \end{bmatrix}$$

phase shift according to

## B.3B HST-SFN scenario for 500 km/h speed

The channel model for this scenario is the same as B.3A, with the following parameters replacing Table B.3A-1:

**Table B.3B-1-500: HST-SFN scenario for higher speed**

Parameter	Value
$D_s$	1000 m
$D_{\min}$	50 m
$v$	500 km/h
$f_d$	972 Hz

## B.3C HST scenario for 500 km/h speed

The channel model for this scenario is the same as B.3, with the following parameters replacing Table B.3-1:

**Table B.3C-1: HST-500 scenario for higher speed**

Parameter	Value
$D_s$	300 m
$D_{\min}$	2 m
$v$	500 km/h
$f_d$	972 Hz

## B.4 Beamforming Model

### B.4.1 Single-layer random beamforming (Antenna port 5, 7, or 8)

Single-layer transmission on antenna port 5 or on antenna port 7 or 8 without a simultaneous transmission on the other antenna port, is defined by using a precoder vector  $W(i)$  of size  $2 \times 1$  or  $4 \times 1$  randomly selected with the number of layers  $\nu = 1$  from Table 6.3.4.2.3-1 or Table 6.3.4.2.3-2 in [4] as beamforming weights. This precoder takes as an input the signal  $y^{(p)}(i)$ ,  $i = 0, 1, \dots, M_{\text{symp}}^{\text{ap}} - 1$ , for antenna port  $p \in \{5, 7, 8\}$ , with  $M_{\text{symp}}^{\text{ap}}$  the number of modulation symbols including the user-specific reference symbols (DRS), and generates a block of signals  $y_{\text{bf}}(i) = [y_{\text{bf}}(i) \ \tilde{y}_{\text{bf}}(i)]^T$  the elements of which are to be mapped onto the same physical RE but transmitted on different antenna elements:

$$\begin{bmatrix} y_{\text{bf}}(i) \\ \tilde{y}_{\text{bf}}(i) \end{bmatrix} = W(i)y^{(p)}(i)$$

Single-layer transmission on antenna port 7 or 8 with a simultaneous transmission on the other antenna port, is defined by using a pair of precoder vectors  $W_1(i)$  and  $W_2(i)$  each of size  $2 \times 1$  or  $4 \times 1$ , which are not identical and randomly selected with the number of layers  $\nu = 1$  from Table 6.3.4.2.3-1 or Table 6.3.4.2.3-2 in [4], as beamforming weights, and normalizing the transmit power as follows:

$$\begin{bmatrix} y_{bf}(i) \\ \tilde{y}_{bf}(i) \end{bmatrix} = \frac{1}{\sqrt{2}} (W_1(i)y^{(7)}(i) + W_2(i)y^{(8)}(i))$$

The precoder update granularity is specific to a test case.

The CSI reference symbols  $a_{k,l}^{(p)}$  satisfying  $p \bmod 2 = 1$ ,  $p \in \{15, 16, \dots, 22\}$ , are transmitted on the same physical antenna element as the modulation symbols  $y_{bf}(i)$ . The CSI reference symbols  $a_{k,l}^{(p)}$  satisfying  $p \bmod 2 = 0$ ,  $p \in \{15, 16, \dots, 22\}$ , are transmitted on the same physical antenna element as the modulation symbols  $\tilde{y}_{bf}(i)$ .

### B.4.1A Single-layer random beamforming (Antenna port 7, 8, 11 or 13 with enhanced DMRS table configured)

Single-layer transmission on antenna port 11 with a simultaneous transmission on one antenna port from antenna port 7, 8 or 13, is defined by using a pair of precoder vectors  $W_1(i)$  and  $W_2(i)$  each of size  $2 \times 1$ , which are not identical and randomly selected with the number of layers  $\nu = 1$  from Table 6.3.4.2.3-1 in [4], as beamforming weights, and normalizing the transmit power as follows:

$$\begin{bmatrix} y_{bf}(i) \\ \tilde{y}_{bf}(i) \end{bmatrix} = \frac{1}{\sqrt{2}} (W_1(i)y^{(11)}(i) + W_2(i)y^{(p_1)}(i))$$

The precoders takes  $y^{(11)}(i)$  and  $y^{(p_1)}(i)$  as the input the signals,  $i = 0, 1, \dots, M_{\text{symp}}^{\text{ap}} - 1$ , with  $M_{\text{symp}}^{\text{ap}}$  the number of modulation symbols including the user-specific reference symbols (DM-RS), and generates a block of signals  $y_{bf}(i) = [y_{bf}(i) \ \tilde{y}_{bf}(i)]^T$  the elements of which are to be mapped onto the same physical RE but transmitted on different antenna elements.

The antenna port  $p_1 \in \{7, 8, 13\}$  update granularity is specific to a test case.

The precoder update granularity is specific to a test case.

The CSI reference symbols  $a_{k,l}^{(p)}$  satisfying  $p \bmod 2 = 1$ ,  $p \in \{15, 16, \dots, 22\}$ , are transmitted on the same physical antenna element as the modulation symbols  $y_{bf}(i)$ . The CSI reference symbols  $a_{k,l}^{(p)}$  satisfying  $p \bmod 2 = 0$ ,  $p \in \{15, 16, \dots, 22\}$ , are transmitted on the same physical antenna element as the modulation symbols  $\tilde{y}_{bf}(i)$ .

### B.4.2 Dual-layer random beamforming (antenna ports 7 and 8)

Dual-layer transmission on antenna ports 7 and 8 is defined by using a precoder matrix  $W(i)$  of size  $2 \times 2$  randomly selected with the number of layers  $\nu = 2$  from Table 6.3.4.2.3-1 in [4] as beamforming weights. This precoder takes as an input a block of signals for antenna ports 7 and 8,  $y(i) = [y^{(7)}(i) \ y^{(8)}(i)]^T$ ,  $i = 0, 1, \dots, M_{\text{symp}}^{\text{ap}} - 1$ , with  $M_{\text{symp}}^{\text{ap}}$  being the number of modulation symbols per antenna port including the user-specific reference symbols, and generates a block of signals  $y_{bf}(i) = [y_{bf}(i) \ \tilde{y}_{bf}(i)]^T$  the elements of which are to be mapped onto the same physical RE but transmitted on different antenna elements:

$$\begin{bmatrix} y_{bf}(i) \\ \tilde{y}_{bf}(i) \end{bmatrix} = W(i) \begin{bmatrix} y^{(7)}(i) \\ y^{(8)}(i) \end{bmatrix},$$

The precoder update granularity is specific to a test case.

The CSI reference symbols  $a_{k,l}^{(p)}$  satisfying  $p \bmod 2 = 1$ ,  $p \in \{15, 16, \dots, 22\}$ , are transmitted on the same physical antenna element as the modulation symbols  $y_{bf}(i)$ . The CSI reference symbols  $a_{k,l}^{(p)}$  satisfying  $p \bmod 2 = 0$ ,  $p \in \{15, 16, \dots, 22\}$ , are transmitted on the same physical antenna element as the modulation symbols  $\tilde{y}_{bf}(i)$ .

### B.4.3 Generic beamforming model (antenna ports 7-14)

The transmission on antenna port(s)  $p = 7, 8, \dots, v + 6$  is defined by using a precoder matrix  $W(i)$  of size  $N_{CSI} \times v$ , where  $N_{CSI}$  is the number of CSI reference signals configured per test and  $v$  is the number of spatial layers. This precoder takes as an input a block of signals for antenna port(s)  $p = 7, 8, \dots, v + 6$ ,

$y^{(p)}(i) = [y^{(7)}(i) \quad y^{(8)}(i) \quad \dots \quad y^{(6+v)}(i)]$ ,  $i = 0, 1, \dots, M_{\text{symb}}^{\text{ap}} - 1$ , with  $M_{\text{symb}}^{\text{ap}}$  being the number of modulation symbols per antenna port including the user-specific reference symbols (DM-RS), and generates a block of signals  $y_{bf}^{(q)}(i) = [y_{bf}^{(0)}(i) \quad y_{bf}^{(1)}(i) \quad \dots \quad y_{bf}^{(N_{CSI}-1)}(i)]^T$  the elements of which are to be mapped onto the same time-frequency index pair  $(k, l)$  but transmitted on different physical antenna elements:

$$\begin{bmatrix} y_{bf}^{(0)}(i) \\ y_{bf}^{(1)}(i) \\ \dots \\ y_{bf}^{(N_{CSI}-1)}(i) \end{bmatrix} = W(i) \begin{bmatrix} y^{(7)}(i) \\ y^{(8)}(i) \\ \dots \\ y^{(6+v)}(i) \end{bmatrix}$$

The precoder matrix  $W(i)$  is specific to a test case.

The physical antenna elements are identified by indices  $j = 0, 1, \dots, N_{ANT} - 1$ , where  $N_{ANT} = N_{CSI}$  is the number of physical antenna elements configured per test.

Modulation symbols  $y_{bf}^{(q)}(i)$  with  $q \in \{0, 1, \dots, N_{CSI} - 1\}$  (i.e. beamformed PDSCH and DM-RS) are mapped to the physical antenna index  $j = q$ .

Modulation symbols  $y^{(p)}(i)$  with  $p \in \{0, 1, \dots, P - 1\}$  (i.e. PBCH, PDCCH, PHICH, PCFICH) are mapped to the physical antenna index  $j = p$ , where  $P$  is the number of cell-specific reference signals configured per test.

Modulation symbols  $a_{k,l}^{(p)}$  with  $p \in \{0, 1, \dots, P - 1\}$  (i.e. CRS) are mapped to the physical antenna index  $j = p$ , where  $P$  is the number of cell-specific reference signals configured per test.

Modulation symbols  $a_{k,l}^{(p)}$  with  $p \in \{15, 16, \dots, 14 + N_{CSI}\}$  (i.e. CSI-RS) are mapped to the physical antenna index  $j = p - 15$ , where  $N_{CSI}$  is the number of CSI reference signals configured per test.

### B.4.4 Random beamforming for EPDCCH distributed transmission (Antenna port 107 and 109)

EPDCCH distributed transmission on antenna port 107 and antenna port 109 is defined by using a pair of precoder vectors  $W_1(i)$  and  $W_2(i)$  each of size  $2 \times 1$ , which are not identical and randomly selected per EPDCCH PRB pair

with the number of layers  $\nu = 1$  from Table 6.3.4.2.3-1 in [4], as beamforming weights. This precoder takes as an input the signal  $y^{(p)}(i)$ ,  $i = 0, 1, \dots, M_{\text{symp}}^{\text{ap}} - 1$ , for antenna port  $p \in \{107, 109\}$ , with  $M_{\text{symp}}^{\text{ap}}$  the number of modulation symbols including the user-specific reference symbols (DMRS), and generates a block of signals  $y_{\text{bf}}(i) = [y_{\text{bf}}(i) \ \tilde{y}_{\text{bf}}(i)]^T$ . When EPDCCH is associated with port 107, the transmitted block of signals is denoted as

$$\begin{bmatrix} y_{\text{bf}}(i) \\ \tilde{y}_{\text{bf}}(i) \end{bmatrix} = W_1(i) y^{(107)}(i).$$

When EPDCCH is associated with port 109, the transmitted block of signals is denoted as

$$\begin{bmatrix} y_{\text{bf}}(i) \\ \tilde{y}_{\text{bf}}(i) \end{bmatrix} = W_2(i) y^{(109)}(i).$$

#### B.4.5 Random beamforming for EPDCCH localized transmission (Antenna port 107, 108, 109 or 110)

EPDCCH localized transmission on antenna port 107, 108, 109 or 110 is defined by using a precoder vector  $W(i)$  of size  $2 \times 1$  randomly selected with the number of layers  $\nu = 1$  from Table 6.3.4.2.3-1 in [4] as beamforming weights. This precoder takes as an input the signal  $y^{(p)}(i)$ ,  $i = 0, 1, \dots, M_{\text{symp}}^{\text{ap}} - 1$ , for antenna port  $p \in \{107, 108, 109, 110\}$ , with  $M_{\text{symp}}^{\text{ap}}$  the number of modulation symbols including the user-specific reference symbols (DMRS), and generates a block of signals  $y_{\text{bf}}(i) = [y_{\text{bf}}(i) \ \tilde{y}_{\text{bf}}(i)]^T$  the elements of which are to be mapped onto the same physical RE but transmitted on different antenna elements:

$$\begin{bmatrix} y_{\text{bf}}(i) \\ \tilde{y}_{\text{bf}}(i) \end{bmatrix} = W(i) y^{(p)}(i).$$

#### B.4.6 Beamforming model for CRI test

The transmission on antenna port(s)  $p = 7, 8, \dots, \nu + 6$  is defined by using a precoder matrix  $W(i)$  of size  $N_{\text{CSI}} \times \nu$ , where  $N_{\text{CSI}}$  is the number of CSI reference signals configured per test and  $\nu$  is the number of spatial layers. This precoder takes as an input a block of signals for antenna port(s)  $p = 7, 8, \dots, \nu + 6$ ,  $y^{(p)}(i) = [y^{(7)}(i) \ y^{(8)}(i) \ \dots \ y^{(6+\nu)}(i)]$ ,  $i = 0, 1, \dots, M_{\text{symp}}^{\text{ap}} - 1$ , with  $M_{\text{symp}}^{\text{ap}}$  being the number of modulation symbols per antenna port including the user-specific reference symbols (DM-RS), and generates a block of signals  $y_{\text{bf}}^{(q)}(i) = [y_{\text{bf}}^{(0)}(i) \ y_{\text{bf}}^{(1)}(i) \ \dots \ y_{\text{bf}}^{(N_{\text{CSI}}-1)}(i)]^T$  the elements of which are to be mapped onto the same time-frequency index pair  $(k, l)$  but transmitted on different physical antenna elements:

$$\begin{bmatrix} y_{\text{bf}}^{(0)}(i) \\ y_{\text{bf}}^{(1)}(i) \\ \dots \\ y_{\text{bf}}^{(N_{\text{CSI}}-1)}(i) \end{bmatrix} = \alpha(n) W(i) \begin{bmatrix} y^{(7)}(i) \\ y^{(8)}(i) \\ \dots \\ y^{(6+\nu)}(i) \end{bmatrix}$$

- $W(i)$  is precoder matrix
- $\alpha(n)$  is amplitude scaling factor for CRI test,  $\alpha(n) = 10^{P_{\theta_m}(n)/20}$
- $P_{\theta_m}(n)$  is power scaling factor as following definition:



- $P_{\theta_m}(n) = A \cos\left(\theta_m + \frac{2\pi m}{K}\right) + B$ ,  $A = 5$  dB,  $B = -1.3351$  dB.
  - $\theta_m$  controls the phase variation, and the phase for m-th subframe is denoted by  $\theta_m = \theta_0 + \Delta\theta \cdot m$ , where  $\theta_0$  is the random start value with the uniform distribution, i.e.,  $\theta_0 \in [0, 2\pi]$ ,  $\Delta\theta$  is the step of phase variation which is defined in Table B.4.6-1, and m is the linear increment of 1 for every sub-frame throughout the simulation.
  - K is the number of configured CSI-RS resources
  - $n \in \{0, 1, \dots, K-1\}$
- For following CRI with multiple CSI-RS resources configured,  $n$  equals to CRI value reported by UE
- For fixed CRI with single CSI-RS resource configure,  $n$  equals to 0.

**Table B.4.6-1: The step of phase variation**

Variation Step	Value (rad/subframe)
$\Delta\theta$	$1.2566 \times 10^{-3}$

The physical antenna elements are identified by indices  $j = 0, 1, \dots, N_{ANT} - 1$ , where  $N_{ANT} = N_{CSI}$  is the number of physical antenna elements configured per test.

Modulation symbols  $y_{bf}^{(q)}(i)$  with  $q \in \{0, 1, \dots, N_{CSI} - 1\}$  (i.e. beamformed PDSCH and DM-RS) are mapped to the physical antenna index  $j = q$ .

For the k-th configured CSI-RS resource, modulation symbols  $a_{k,j}^{(p)}$  with  $p \in \{1, 5, 16, \dots, 14 + N_{CSI}\}$  (i.e. CSI-RS) are firstly multiplied by amplitude scaling factor  $\alpha(n)$  to generate power scaled symbols  $y_{k,j}^{(p)}$ :

$$y_{k,j}^{(p)} = \alpha(n) a_{k,j}^{(p)}$$

- $n$  equals to CSI-RS resource index (k-th)

And power scaled symbols  $y_{k,j}^{(p)}$  with  $p \in \{1, 5, 16, \dots, 14 + N_{CSI}\}$  (i.e. power scaled CSI-RS) are mapped to the physical antenna index  $j = p - 15$ , where  $N_{CSI}$  is the number of CSI reference signals configured per test.

Modulation symbols  $y^{(p)}(i)$  with  $p \in \{0, 1, \dots, P - 1\}$  (i.e. PBCH, PDCCH, PHICH, PCFICH) are mapped to the physical antenna index  $j = p$ , where  $P$  is the number of cell-specific reference signals configured per test.

Modulation symbols  $a_{k,j}^{(p)}$  with  $p \in \{0, 1, \dots, P - 1\}$  (i.e. CRS) are mapped to the physical antenna index  $j = p$ , where  $P$  is the number of cell-specific reference signals configured per test.

---

## B.5 Interference models for enhanced performance requirements Type-A

This clause provides a description for the modelling of interfering cell transmissions for enhanced performance requirements Type-A including: definition of dominant interferer proportion, transmission mode 3, 4 and 9 type of interference modelling.

## B.5.1 Dominant interferer proportion

Each interfering cell involved in enhanced performance requirements Type-A is characterized by its associated dominant interferer proportion (DIP) value:

$$DIP_i = \frac{\hat{I}_{or(i+1)}}{N_{oc}'}$$

where  $\hat{I}_{or(i+1)}$  is the average received power spectral density from the  $i$ -th strongest interfering cell involved in the requirement scenario ( $\hat{I}_{or(1)}$  is assumed to be the power spectral density associated with the serving cell) and

$N_{oc}' = \sum_{j=2}^N \hat{I}_{or(j)} + N_{oc}$  where  $N_{oc}$  is the average power spectral density of a white noise source consistent with the

definition provided in subclause 3.2 and  $N$  is the total number of cells involved in a given requirement scenario.

## B.5.2 Transmission mode 3 interference model

This subclause provides transmission mode 3 interference modelling for each explicitly modelled interfering cell in the requirement scenario. In each subframe, each interfering cell shall transmit randomly modulated data over the entire PDSCH region and the full transmission bandwidth. Transmitted physical channels shall include PSS, SSS and PBCH.

For each subframe and each CQI subband as defined in subclause 7.2 of [6], a transmission rank shall be randomly determined independently from other CQI subbands as well as other interfering cells. Probabilities of occurrence of each possible transmission rank are as specified in the requirement scenario.

For rank-1 transmission over a subband, precoding for transmit diversity for the number of antenna ports in the requirement scenario shall be applied to 16QAM randomly modulated layer symbols, as specified in subclause 6.3.4.3 of [4].

For rank-2 transmission over a subband, precoding for spatial multiplexing with large delay CDD over two layers for the number of antenna ports in the requirement scenario shall be applied to 16QAM randomly modulated layer symbols, as specified in subclause 6.3.4.2.2 of [4].

For unallocated REs in the control region, precoding for transmit diversity for the number of antenna ports in the requirement scenario shall be applied to QPSK randomly modulated layer symbols, as specified in subclause 6.3.4.3 of [4]. The EPRE ratio for these REs shall be as defined for PDCCH in Annex C.3.2.

## B.5.3 Transmission mode 4 interference model

This subclause provides transmission mode 4 interference modelling for each explicitly modelled interfering cell in the requirement scenario. In each subframe, each interfering cell shall transmit randomly modulated data over the entire PDSCH region and the full transmission bandwidth according to the probabilities of occurrence. Transmitted physical channels shall include PSS, SSS and PBCH. Probabilities of occurrence in each subframe are as specified in the requirement scenario. If the probabilities of occurrence in each subframe are not specified in the requirement scenario, as default, they are equal to 1.

For each subframe and each CQI subband as defined in subclause 7.2 of [6], a transmission rank shall be randomly determined independently from other CQI subbands as well as other interfering cells. Probabilities of occurrence of each possible transmission rank are as specified in the requirement scenario.

For each subframe and CQI subband, a precoding matrix for the number of layers  $\nu$  associated to the selected rank shall be selected randomly from Table 6.3.4.2.3-1 of [4]. Note that codebook index 0 shall be excluded from random precoder selection when the number of layers is  $\nu = 2$ .

Precoding for spatial multiplexing with cell-specific reference signals for the number of antenna ports in the requirement scenario shall be applied to 16QAM randomly modulated layer symbols, as specified in subclause 6.3.4.2.1 of [4] with the selected precoding matrices for each subframe and each CQI subband.

For unallocated REs in the control region, precoding for transmit diversity for the number of antenna ports in the requirement scenario shall be applied to QPSK randomly modulated layer symbols, as specified in subclause 6.3.4.3 of [4]. The EPRE ratio for these REs shall be as defined for PDCCH in Annex C.3.2.

## B.5.4 Transmission mode 9 interference model

This subclause provides transmission mode 9 interference modelling for each explicitly modelled interfering cell in the requirement scenario. In each subframe, each interfering cell shall transmit randomly modulated data over the entire PDSCH region and the full transmission bandwidth according to the probabilities of occurrence. Transmitted physical channels shall include PSS, SSS and PBCH. Probabilities of occurrence in each subframe are as specified in the requirement scenario. If the probabilities of occurrence in each subframe are not specified in the requirement scenario, as default, they are equal to 1.

For each subframe and each CQI subband as defined in subclause 7.2 of [6], a transmission rank shall be randomly determined independently from other CQI subbands as well as other interfering cells. Probabilities of occurrence of each possible transmission rank are as specified in the requirement scenario.

For each subframe and each CQI subband, a precoding matrix for the number of layers  $v$  associated to the selected rank shall be selected randomly from Table 6.3.4.2.3-2 of [4].

The generic beamforming model in subclause B.4.3 shall be applied assuming cell-specific reference signals and CSI reference signals as specified in the requirement scenario. Random precoding with selected rank and precoding matrices for each subframe and each CQI subband shall be applied to 16QAM randomly modulated layer symbols including the user-specific reference symbols over antenna port 7 when the rank is one and antenna ports 7, 8 when the rank is two.

For unallocated REs in the control region, precoding for transmit diversity for the number of antenna ports in the requirement scenario shall be applied to QPSK randomly modulated layer symbols, as specified in subclause 6.3.4.3 of [4]. The EPRE ratio for these REs shall be as defined for PDCCH in Annex C.3.2.

---

## B.6 Interference models for enhanced performance requirements Type-B

This clause provides a description for the modelling of interfering cell transmissions for enhanced performance requirements Type-B including: transmission mode 2, 3, 4 and 9 type of interference modelling and a definition of the random interference model.

### B.6.1 Transmission mode 2 interference model

This subclause provides transmission mode 2 interference modelling for each explicitly modelled interfering cell in the requirement scenario. In each subframe, each interfering cell shall transmit randomly modulated data over the PDSCH region as specified in subclause B.6.6. Transmitted physical channels shall include PSS, SSS and PBCH.

The MCS shall be randomly determined with probabilities of occurrence of each possible MCS as specified in subclause B.6.6.

Precoding for transmit diversity for the number of antenna ports in the requirement scenario shall be applied to the randomly modulated layer symbols, as specified in subclause 6.3.4.3 of [4].

For unallocated REs in the control region, precoding for transmit diversity for the number of antenna ports in the requirement scenario shall be applied to QPSK randomly modulated layer symbols, as specified in subclause 6.3.4.3 of [4]. The EPRE ratio for these REs shall be as defined for PDCCH in Annex C.3.2.

### B.6.2 Transmission mode 3 interference model

This subclause provides transmission mode 3 interference modelling for each explicitly modelled interfering cell in the requirement scenario. In each subframe, each interfering cell shall transmit randomly modulated data over the PDSCH region as specified in subclause B.6.6. Transmitted physical channels shall include PSS, SSS and PBCH.

The transmission rank shall be randomly determined for each user defined in section B.6.6 with probabilities of occurrence of each possible transmission rank as specified in subclause B.6.6.

The MCS shall be randomly determined with probabilities of occurrence of each possible MCS as specified in subclause B.6.6.

For rank-1 transmission, precoding for transmit diversity for the number of antenna ports in the requirement scenario shall be applied to the randomly modulated layer symbols, as specified in subclause 6.3.4.3 of [4].

For rank-2 transmission, precoding for spatial multiplexing with large delay CDD over two layers for the number of antenna ports in the requirement scenario shall be applied to the randomly modulated layer symbols, as specified in subclause 6.3.4.2.2 of [4].

For unallocated REs in the control region, precoding for transmit diversity for the number of antenna ports in the requirement scenario shall be applied to QPSK randomly modulated layer symbols, as specified in subclause 6.3.4.3 of [4]. The EPRE ratio for these REs shall be as defined for PDCCH in Annex C.3.2.

### B.6.3 Transmission mode 4 interference model

This subclause provides transmission mode 4 interference modelling for each explicitly modelled interfering cell in the requirement scenario. In each subframe, each interfering cell shall transmit randomly modulated data over the PDSCH region as specified in subclause B.6.6. Transmitted physical channels shall include PSS, SSS and PBCH.

The transmission rank shall be randomly determined with probabilities of occurrence of each possible transmission rank as specified in subclause B.6.6.

The MCS shall be randomly determined with probabilities of occurrence of each possible MCS as specified in subclause B.6.6.

For each TTI, for each user defined in B.6.6, a single precoding matrix for the number of layers  $\nu$  associated to the selected rank shall be selected randomly from Table 6.3.4.2.3-1 of [4]. Note that codebook index 0 shall be excluded from random precoder selection when the number of layers is  $\nu = 2$ .

Precoding for spatial multiplexing with cell-specific reference signals for the number of antenna ports in the requirement scenario shall be applied to randomly modulated layer symbols, as specified in subclause 6.3.4.2.1 of [4] with the selected precoding matrices as specified in subclause B.6.6.

For unallocated REs in the control region, precoding for transmit diversity for the number of antenna ports in the requirement scenario shall be applied to QPSK randomly modulated layer symbols, as specified in subclause 6.3.4.3 of [4]. The EPRE ratio for these REs shall be as defined for PDCCH in Annex C.3.2.

### B.6.4 Transmission mode 9 interference model

This subclause provides transmission mode 9 interference modelling for each explicitly modelled interfering cell in the requirement scenario. In each subframe, each interfering cell shall transmit randomly modulated data over the PDSCH region as specified in subclause B.6.6. Transmitted physical channels shall include PSS, SSS and PBCH.

The transmission rank shall be randomly determined with probabilities of occurrence of each possible transmission rank as specified in subclause B.6.6.

The MCS shall be randomly determined with probabilities of occurrence of each possible MCS as specified in subclause B.6.6.

For each TTI, for each user defined in B.6.6, a single precoding matrix for the number of layers  $\nu$  associated to the selected rank shall be selected randomly from Table 6.3.4.2.3-1 of [4]. Note that codebook index 0 shall be excluded from random precoder selection when the number of layers is  $\nu = 2$ .

The generic beamforming model in subclause B.4.3 shall be applied assuming cell-specific reference signals and CSI reference signals as specified in the requirement scenario. Random precoding with selected rank and precoding matrices for each subframe shall be applied to randomly modulated layer symbols including the user-specific reference symbols over antenna port 7 when the rank is one and antenna ports 7, 8 when the rank is two.

For each TTI, for each user defined in B.6.6, the scrambling ID value nSCID is randomly assigned from the set of {0,1}.

For unallocated REs in the control region, precoding for transmit diversity for the number of antenna ports in the requirement scenario shall be applied to QPSK randomly modulated layer symbols, as specified in subclause 6.3.4.3 of [4]. The EPRE ratio for these REs shall be as defined for PDCCH in Annex C.3.2.

## B.6.5 CRS interference model

This subclause provides for the CRS interference modelling for each explicitly modelled interfering cell in the requirement scenario. In each subframe there is no PDSCH transmitted. Transmitted physical channels shall include PSS, SSS and PBCH.

For unallocated REs in the control region, precoding for transmit diversity for the number of antenna ports in the requirement scenario shall be applied to QPSK randomly modulated layer symbols, as specified in subclause 6.3.4.3 of [4]. The EPRE ratio for these REs shall be as defined for PDCCH in Annex C.3.2.

## B.6.6 Random interference model

This subclause presents the interference model which defines the resource allocation, MCS and rank for the two interference cells. The model includes approximately 10% DTX on these interference cells. Table B.6.6-1 shows the resource allocation for four users in two different configurations for each of the two interferers. Table B.6.6-2 shows the resource allocation to be used for special subframes with TM9 interference. Table B.6.6-3 shows the probabilities for the MSC and rank for these users.

**Table B.6.6-1: Resource allocation for the random interference model**

Resource allocation configurations Indexes	User Index	Resource allocation for random interference model				Probability
		Resource allocation type	Bitmap for resource allocation (Note 1)			
			1st field bitmap	2nd field bitmap	3rd field bitmap	
Configuration 1	User 0	1	00	0	10101000101010	50%
	User 1	1	00	0	01010101010101	
	User 2	0	01001001001001001			
	User 3	0	00100100100100100			
Configuration 2	User 0	1	00	0	10101010101010	50%
	User 1	1	00	1	01010100010101	
	User 2	0	01001001001001001			
	User 3	0	00100100100100100			
Note 1: The 1 <sup>st</sup> , 2 <sup>nd</sup> , and 3 <sup>rd</sup> field bitmaps are only valid for resource allocation type 1 which was defined in [6].						
Note 2: The resource allocation model is used for both 1 <sup>st</sup> and 2 <sup>nd</sup> interfering cells and the resource allocation is independent for each interfering cell.						

**Table B.6.6-2: Resource allocation for the random interference model for TM9 special subframes**

Resource allocation configurations Indexes	User Index	Resource allocation for random interference model				Probability
		Resource allocation type	Bitmap for resource allocation (Note 1)			
			1st field bitmap	2nd field bitmap	3rd field bitmap	
Configuration 1	User 0	1	00	0	10101000101010	50%
	User 1	1	00	0	01010101000001	
	User 2	0	01001000001001001			
	User 3	0	00100100000100100			
Configuration 2	User 0	1	00	0	10101000101010	50%
	User 1	1	00	1	01010000010101	
	User 2	0	01001000001001001			
	User 3	0	00100100000100100			
Note 1: The 1 <sup>st</sup> , 2 <sup>nd</sup> , and 3 <sup>rd</sup> field bitmaps are only valid for resource allocation type 1 which was defined in [6].						
Note 2: The resource allocation model is used for both 1 <sup>st</sup> and 2 <sup>nd</sup> interfering cells and the resource allocation is independent for each interfering cell.						

**Table B.6.6-3 MCS and rank configuration for the random interference model**

MCS probability			Rank probability	
MCS5	MCS14	MCS25	Rank 1	Rank 2
50%	25%	25%	80%	20%
Note 1: The MCS and rank should follow the probability indicated in the table randomly per UE per TTI.				
Note 2: The probabilities for MCS and rank configuration are used for both 1 <sup>st</sup> and 2 <sup>nd</sup> interfering cells. The MCS and rank configurations are independent for each interfering cell.				

## B.7 Interference models for enhanced downlink control channel performance requirements Type A and B

This clause provides a description for the modelling of interfering cell transmissions for the enhanced downlink control channel performance requirements Type A and B.

### B.7.1 PDCCH, PCFICH and PHICH interference model

This subclause provides a description of the interfering cell transmissions model for the enhanced PDCCH/PCFICH and PHICH downlink control channel performance requirements Type A and B under synchronous network scenarios.

The transmitted physical signals and channels shall include CRS, PSS, SSS, PBCH and PCFICH. The PDCCH and PHICH transmit signals are emulated as virtual PDCCH signals described further in the clause.

The PDCCH signals are modelled with a per control channel element (CCE) level granularity and have guaranteed 50% CCE resource loading in each subframe. For each subframe the set of active and inactive CCEs is derived in accordance to the following procedure:

- 1) All available CCEs for the PDCCH and PHICH are marked as  $CCE_0, CCE_1, \dots, CCE_{N-1}$ .
- 2) For the given partial loading ratio  $X = 50\%$  the numbers of active CCEs  $M_{Active}$  and inactive CCEs  $M_{Inactive}$  are derived

$$M_{Inactive} = \lfloor N * (100 - X \%) \rfloor$$

$$M_{Active} = N - M_{Inactive}$$

- 3) The indexes of  $M_{Inactive}$  inactive CCEs are randomly selected out of the full set of CCEs.
- 4) The remaining  $M_{Active}$  CCEs are assigned to be active.

No signals are transmitted in the REs corresponding to the inactive CCEs. The PDCCH signals are transmitted in the REs corresponding to the active CCEs. For PDCCH REs, precoding for transmit diversity for the number of antenna ports in the requirement scenario shall be applied to QPSK randomly modulated layer symbols, as specified in subclause 6.3.4.3 of [4]. The EPRE ratio of the PDCCH REs in the active CCEs shall be derived in accordance to the following procedure:

- 1) For each generated active  $i$ -th CCE the PDCCH power boosting level  $P(i)$  shall be randomly generated using the uniform distribution in the  $[P_{min}, P_{max}]$  range. The  $P_{min}$  is equal to -6 dB, the  $P_{max}$  is equal to 6 dB. The random values should be derived in the dB scale.
- 2) Additional power normalization is applied for each generated  $i$ -th PDCCH power boosting level:

$$P_{norm}(i) = P(i) - \alpha$$

where  $P(i)$  and  $P_{norm}(i)$  are the PDCCH power boosting coefficients before and after normalization in the dB scale; the power normalization factor  $\alpha$  is equal to 1.3 dB.

- 3) The normalized PDCCH power boosting coefficients  $P_{norm}(i)$  are further applied to the PDCCH\_RA and PDCCH\_RB values to derive the EPRE ratio of the PDCCH signals transmitted in the REs corresponding the  $i$ -th CCE in each subframe.

## B.8 Burst transmission models for Frame structure type 3

This clause provides a description for burst transmission models for Frame structure type 3.

### B.8.1 Burst transmission model for one LAA SCell

One burst is defined as downlink transmissions which occupy one or more consecutive subframes. The burst transmission format is determined according to the steps below:

- 1) Select the number of subframes  $N$  randomly from a given set of the number of subframes  $S_1$  with equal probability as the total length of burst transmission format. The length includes both occupied OFDM symbols and non-occupied OFDM symbols within the burst format.  $S_1$  is given per test case.
- 2) If  $N$  is equal to 1, the subframe is set as fully occupied, otherwise:
  - For demodulation test, the starting position for the first subframe is randomly selected from OFDM symbol 0 and OFDM symbol 7 with equal probability. For CSI test, the starting position for the first subframe is OFDM symbol 0.
  - The configuration of occupied OFDM symbols in the last subframe is randomly selected from configuration set  $S_2$ .  $S_2$  is given per test case.

A uniform random variable from [0, 1] is generated. If the random variable is less than  $p$  which is given per test case,

- If both the last subframe of previous burst and first subframe of new burst format are fully occupied, start burst transmission after deferring one subframe from the last subframe of previous burst. Otherwise, start burst transmission at the end of last subframe of previous burst.

Otherwise, the burst transmission is muted and the muting duration is the same as the number of subframes for determined burst format.

### B.8.2 Burst transmission model for multiple LAA SCell(s)

This clause provides a description for burst transmission models for Frame structure type 3 when there are multiple LAA SCell(s) in the test.

One burst is defined as downlink transmissions which occupy one or more consecutive subframes. Assuming  $M$  carriers are configured, the burst transmission format is determined according to the steps below:

- 1) For each carrier  $c_m$  ( $m=0, \dots, M-1$ ), select the number of subframes  $N_m$  randomly from a given set of the number of subframes  $S_1$  with equal probability as the total length of burst transmission format used for carrier  $c_m$ . The length includes both occupied OFDM symbols and non-occupied OFDM symbols within the burst format.  $S_1$  is given per test case.
- 2) If any  $N_m$  is equal to 1, the first subframe is set as fully occupied for all carriers, otherwise:
  - For demodulation test, the starting position for the first subframe is randomly selected from OFDM symbol 0 and OFDM symbol 7 with equal probability. For CSI test, the starting position for the first subframe is OFDM symbol 0. The starting position is common for all carriers.
  - The configuration of occupied OFDM symbols in the last subframe is randomly selected from configuration set  $S_2$  for each carrier  $c_m$ .  $S_2$  is given per test case.

A uniform random variable  $p_m$  from [0, 1] is generated for each carrier  $c_m$  to determine whether the burst is transmitted or not on each carrier.

For each carrier  $c_m$ , if  $p_m$  is less than  $p$  which is given per test case,

- If both the last subframe of previous longest transmitted burst over  $M$  carriers and first subframe of new burst format are fully occupied, start burst transmission according to the determined burst transmission format for this carrier after deferring one subframe from the last subframe of previous longest transmitted burst. Otherwise, start burst transmission for this carrier at the end of last subframe of previous longest transmitted burst.

Otherwise, the burst transmission is muted and the muting duration is  $N_{max}$  and  $N_{max}$  is the maximum of  $N_j$  wherein  $j \in \{0, 1, \dots, M-1\}$  and  $p_j$  is less than  $p$ .



## Annex C (normative): Downlink Physical Channels

### C.1 General

This annex specifies the downlink physical channels that are needed for setting a connection and channels that are needed during a connection.

### C.2 Set-up

Table C.2-1 describes the downlink Physical Channels that are required for connection set up.

**Table C.2-1: Downlink Physical Channels required for connection set-up**

Physical Channel
PBCH
SSS
PSS
PCFICH
PDCCH
EPDCCH
PHICH
PDSCH

### C.3 Connection

The following clauses, describes the downlink Physical Channels that are transmitted during a connection i.e., when measurements are done.

#### C.3.1 Measurement of Receiver Characteristics

Unless otherwise stated, Table C.3.1-1 is applicable for measurements on the Receiver Characteristics (clause 7).

**Table C.3.1-1: Downlink Physical Channels transmitted during a connection (FDD and TDD)**

Physical Channel	EPRE Ratio
PBCH	PBCH_RA = 0 dB
	PBCH_RB = 0 dB
PSS	PSS_RA = 0 dB
SSS	SSS_RA = 0 dB
PCFICH	PCFICH_RB = 0 dB
PDCCH	PDCCH_RA = 0 dB
	PDCCH_RB = 0 dB
PDSCH	PDSCH_RA = 0 dB
	PDSCH_RB = 0 dB
OCNG	OCNG_RA = 0 dB
	OCNG_RB = 0 dB

NOTE 1: No boosting is applied.

For measurements on cells in TDD Band 46, Table C.3.1-1a is applicable for measurements of Receiver Characteristics (clause 7).

**Table C.3.1-1a: Downlink Physical Channels transmitted during a connection (TDD Band 46)**

Physical Channel	EPRE Ratio
DRS	NOTE 1
PSS	PSS_RA = 0 dB
SSS	SSS_RA = 0 dB
PCFICH	PCFICH_RB = 0 dB
PDCCH	PDCCH_RA = 0 dB
	PDCCH_RB = 0 dB
PDSCH	PDSCH_RA = 0 dB
	PDSCH_RB = 0 dB
OCNG	OCNG_RA = 0 dB
	OCNG_RB = 0 dB
NOTE 1: No boosting is applied.	

**Table C.3.1-2: Power allocation for OFDM symbols and reference signals**

Parameter	Unit	Value	Note
Transmitted power spectral density $I_{or}$	dBm/15 kHz	Test specific	1. $I_{or}$ shall be kept constant throughout all OFDM symbols
Cell-specific reference signal power ratio $E_{RS} / I_{or}$		0 dB	

## C.3.2 Measurement of Performance requirements

Table C.3.2-1 is applicable for measurements in which uniform RS-to-EPRE boosting for all downlink physical channels, unless otherwise stated.

**Table C.3.2-1: Downlink Physical Channels transmitted during a connection (FDD and TDD and Frame structure Type 3)**

Physical Channel	EPRE Ratio
PBCH	PBCH_RA = $\rho_A + \sigma$
	PBCH_RB = $\rho_B + \sigma$
PSS	PSS_RA = 0 (Note 3)
SSS	SSS_RA = 0 (Note 3)
PCFICH	PCFICH_RB = $\rho_B + \sigma$
PDCCH	PDCCH_RA = $\rho_A + \sigma$
	PDCCH_RB = $\rho_B + \sigma$
EPDCCH	EPDCCH_RA = $\rho_A + \delta$
	EPDCCH_RB = $\rho_B + \delta$
MPDCCH	MPDCCH_RA = $\rho_A + \delta$
	MPDCCH_RB = $\rho_B + \delta$
SPDCCH (CRS-based)	SPDCCH_RA = $\rho_A + \sigma$
	SPDCCH_RB = $\rho_B + \sigma$
SPDCCH (DMRS-based)	SPDCCH_RA = $\rho_A + \delta$
	SPDCCH_RB = $\rho_B + \delta$
PDSCH	PDSCH_RA = $\rho_A$
	PDSCH_RB = $\rho_B$
PMCH	PMCH_RA = $\rho_A$
	PMCH_RB = $\rho_B$
MBSFN RS	MBSFN_RS_RA = $\rho_A$
	MBSFN_RS_RB = $\rho_B$
OCNG	OCNG_RA = $\rho_A + \sigma$
	OCNG_RB = $\rho_B + \sigma$

NOTE 1:  $\rho_A = \rho_B = 0$  dB means no RS boosting.

NOTE 2: MBSFN RS and OCNG are not defined downlink physical channels in [4].

NOTE 3: Assuming PSS and SSS transmitted on a single antenna port.

NOTE 4:  $\rho_A$ ,  $\rho_B$ ,  $\sigma$ , and  $\delta$  are test specific.

NOTE 5: Void.

NOTE 6: For Frame Structure Type 3, PBCH are not defined.

**Table C.3.2-2: Power allocation for OFDM symbols and reference signals**

Parameter	Unit	Value	Note
Total transmitted power spectral density $I_{or}$	dBm/15 kHz	Test specific	1. $I_{or}$ shall be kept constant throughout all OFDM symbols
Cell-specific reference signal power ratio $E_{RS} / I_{or}$		Test specific	1. Applies for antenna port $p$
Energy per resource element EPRE		Test specific	1. The complex-valued symbols $y^{(p)}(i)$ and $a_{k,l}^{(p)}$ defined in [4] shall conform to the given EPRE value. 2. For TM8, TM9 and TM10 the reference point for EPRE is before the precoder in Annex B.4.

### C.3.3 Aggressor cell power allocation for Measurement of Performance Requirements when ABS is Configured

For the performance requirements and channel state information reporting when ABS is configured, the power allocation for the physical channels of the aggressor cell in non-ABS and ABS is listed in Table C.3.3-1.

**Table C.3.3-1: Downlink physical channels transmitted in aggressor cell when ABS is configured in this cell**

Physical Channel	Parameters	Unit	EPRE Ratio	
			Non-ABS	ABS
PBCH	PBCH_RA	dB	$\rho_A$	Note 1
	PBCH_RB	dB	$\rho_B$	Note 1
PSS	PSS_RA	dB	$\rho_A$	Note 1
SSS	SSS_RA	dB	$\rho_A$	Note 1
PCFICH	PCFICH_RB	dB	$\rho_B$	Note 1
PHICH	PHICH_RA	dB	$\rho_A$	Note 1
	PHICH_RB	dB	$\rho_B$	Note 1
PDCCH	PDCCH_RA	dB	$\rho_A$	Note 1
	PDCCH_RB	dB	$\rho_B$	Note 1
PDSCH	PDSCH_RA	dB	N/A	Note 1
	PDSCH_RB	dB	N/A	Note 1
OCNG	OCNG_RA	dB	$\rho_A$	Note 1
	OCNG_RB	dB	$\rho_B$	Note 1

Note 1:  $-\infty$  dB is allocated for this channel in this test.

**Table C.3.3-2: Downlink physical channels transmitted in aggressor cell when ABS is configured in this cell when the CRS assistance information is provided**

Physical Channel	Parameters	Unit	EPRE Ratio	
			Non-ABS	ABS
PBCH	PBCH_RA	dB	$\rho_A$	$\rho_A$
	PBCH_RB	dB	$\rho_B$	$\rho_B$
PSS	PSS_RA	dB	$\rho_A$	$\rho_A$
SSS	SSS_RA	dB	$\rho_A$	$\rho_A$
PCFICH	PCFICH_RB	dB	$\rho_B$	Note 1
PHICH	PHICH_RA	dB	$\rho_A$	Note 1
	PHICH_RB	dB	$\rho_B$	Note 1
PDCCH	PDCCH_RA	dB	$\rho_A$	Note 1
	PDCCH_RB	dB	$\rho_B$	Note 1
PDSCH	PDSCH_RA	dB	N/A	Note 1
	PDSCH_RB	dB	N/A	Note 1
OCNG	OCNG_RA	dB	$\rho_A$	Note 1
	OCNG_RB	dB	$\rho_B$	Note 1

Note 1:  $-\infty$  dB is allocated for this channel in this test.

### C.3.4 Power Allocation for Measurement of Performance Requirements when Quasi Co-location Type B: same Cell ID

For the performance requirements related to quasi-colocation type B behaviour when transmission points share the same Cell ID, the power allocation for the physical channels of the serving cell is listed in Table C.3.4-1 and the power allocation for the physical channels of the cell transmitting PDSCH is listed in Table C.3.4-2

**Table C.3.4-1: Downlink physical channels transmitted in the serving cell (TP1)**

Physical Channel	EPRE Ratio
PBCH	PBCH_RA = $\rho_A + \sigma$
	PBCH_RB = $\rho_B + \sigma$
PSS	PSS_RA = 0 (Note 2)
SSS	SSS_RA = 0 (Note 2)
PDSCH	PDSCH_RA = $\rho_A$
	PDSCH_RB = $\rho_B$
PCFICH	PCFICH_RB = $\rho_B + \sigma$
PDCCH	PDCCH_RA = $\rho_A + \sigma$
	PDCCH_RB = $\rho_B + \sigma$

NOTE 1:  $\rho_A = \rho_B = 0$  dB means no RS boosting.

NOTE 2: Assuming PSS and SSS transmitted on a single antenna port.

NOTE 3:  $\rho_A$ ,  $\rho_B$  and  $\sigma$  are test specific.

**Table C.3.4-2: Downlink physical channels for the transmission point transmitting PDSCH (TP2)**

Physical Channel	Value
PDSCH	Test Specific

### C.3.5 Simplified CA testing method

For CA tests which require more than 16 independent faders, if a test system cannot support a throughput measurement with fading on all carriers simultaneously, the simplified CA testing method shall be used.

In the simplified CA testing method, the resulting propagation channel(s) shall be generated by considering a number of independent faders needed for one carrier and connecting them to the signal of randomly chosen carrier(s). The maximum number of channel faders on the test will be less than or equal to 16. The remaining carrier(s) shall be connected without a channel fader but with AWGN. The throughput is then collected only for the carrier(s) connected to channel faders.

In the simplified CA testing method, the test shall be repeated by choosing carrier(s) excluding already chosen carrier(s) until all the carrier(s) are tested under fading conditions. All the collected throughputs from each carrier shall be compared against the reference value of the requirements.

All supported carriers shall be configured and activated during the test.

### C.3.6 Measurement of Receiver Characteristics for Narrowband IoT

For the performance requirements for Narrowband IoT, the power allocation for the physical channels is listed in Table C.3.6-1

**Table C.3.6-1: Downlink Physical Channels transmitted during a connection**

Physical Channel	EPRE Ratio for one NRS antenna port	EPRE Ratio for two NRS antenna ports
NPBCH	0 dB	-3 dB
NPDCCH	0 dB	-3 dB
NPDSCH	0 dB	-3 dB
NPSS	0 dB	0 dB
NSSS	0 dB	0 dB

NOTE 1: Assuming NPSS and NSSS transmitted on one NRS antenna port.

**Table C.3.6-2: Power allocation for OFDM symbols and reference signals**

Parameter	Unit	Value	Note
Transmitted power spectral density $I_{or}$	dBm/15 kHz	Test specific	$I_{or}$ shall be kept constant throughout all OFDM symbols
Cell-specific reference signal power ratio $E_{CRS} / I_{or}$		0 dB	Applicable for In-band operation
Narrowband reference signal power ratio $E_{NRS} / I_{or}$		0 dB	Applicable for Stand-alone and Guard-band operation
Narrowband reference signal power over cell-specific reference signal power $E_{NRS} / E_{RS}$		0 dB	Applicable for In-band operation

## Annex D (normative): Characteristics of the interfering signal

### D.1 General

Unless otherwise stated, when the channel bandwidth is wider or equal to 5MHz, a modulated 5MHz full bandwidth E-UTRA downlink signal and CW signal are used as interfering signals when RF performance requirements for E-UTRA UE receiver are defined. For channel bandwidths below 5MHz, the bandwidth of modulated interferer should be equal to bandwidth of the received signal.

For Band 46, the bandwidth of interfering signal is 20MHz when RF performance requirements for E-UTRA UE receiver are defined.

### D.2 Interference signals

Table D.2-1 describes the modulated interferer for different channel bandwidth options.

**Table D.2-1: Description of modulated E-UTRA interferer**

	Channel bandwidth					
	1.4 MHz	3 MHz	5 MHz	10 MHz	15 MHz	20 MHz
$BW_{interferer}$	1.4 MHz	3 MHz	5 MHz	5 MHz	5 MHz	5 MHz
RB	6	15	25	25	25	25

Table D.2-2 describes the modulated interferer setting 2 for different channel bandwidth options for Band 46.

**Table D.2-2: Description of modulated E-UTRA interferer for Band 46**

	Channel bandwidth					
	1.4 MHz	3 MHz	5 MHz	10 MHz	15 MHz	20 MHz
$BW_{interferer}$						20 MHz
RB						100

## Annex E (normative): Environmental conditions

### E.1 General

This normative annex specifies the environmental requirements of the UE. Within these limits the requirements of the present documents shall be fulfilled.

### E.2 Environmental

The requirements in this clause apply to all types of UE(s).

#### E.2.1 Temperature

The UE shall fulfil all the requirements in the full temperature range of:

**Table E.2.1-1**

+15 °C to +35 °C	for normal conditions (with relative humidity of 25 % to 75 %)
-10 °C to +55 °C	for extreme conditions (see IEC publications 68-2-1 and 68-2-2)

Outside this temperature range the UE, if powered on, shall not make ineffective use of the radio frequency spectrum. In no case shall the UE exceed the transmitted levels as defined in clause 6.2 for extreme operation.

#### E.2.2 Voltage

The UE shall fulfil all the requirements in the full voltage range, i.e. the voltage range between the extreme voltages.

The manufacturer shall declare the lower and higher extreme voltages and the approximate shutdown voltage. For the equipment that can be operated from one or more of the power sources listed below, the lower extreme voltage shall not be higher, and the higher extreme voltage shall not be lower than that specified below.

**Table E.2.2-1**

Power source	Lower extreme voltage	Higher extreme voltage	Normal conditions voltage
AC mains	0,9 * nominal	1,1 * nominal	nominal
Regulated lead acid battery	0,9 * nominal	1,3 * nominal	1,1 * nominal
Non regulated batteries:			
Leclanché	0,85 * nominal	Nominal	Nominal
Lithium	0,95 * nominal	1,1 * Nominal	1,1 * Nominal
Mercury/nickel & cadmium	0,90 * nominal		Nominal

Outside this voltage range the UE if powered on, shall not make ineffective use of the radio frequency spectrum. In no case shall the UE exceed the transmitted levels as defined in clause 6.2 for extreme operation. In particular, the UE shall inhibit all RF transmissions when the power supply voltage is below the manufacturer declared shutdown voltage.

## E.2.3 Vibration

The UE shall fulfil all the requirements when vibrated at the following frequency/amplitudes.

**Table E.2.3-1**

Frequency	ASD (Acceleration Spectral Density) random vibration
5 Hz to 20 Hz	0,96 m <sup>2</sup> /s <sup>3</sup>
20 Hz to 500 Hz	0,96 m <sup>2</sup> /s <sup>3</sup> at 20 Hz, thereafter -3 dB/Octave

Outside the specified frequency range the UE, if powered on, shall not make ineffective use of the radio frequency spectrum. In no case shall the UE exceed the transmitted levels as defined in TS 36.101 for extreme operation.



## Annex F (normative): Transmit modulation

### F.1 Measurement Point

Figure F.1-1 shows the measurement point for the unwanted emission falling into non-allocated RB(s) and the EVM for the allocated RB(s).

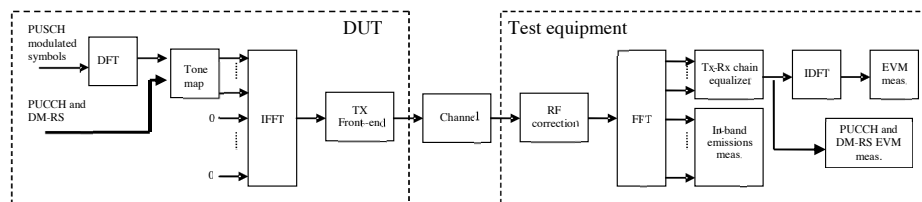

Figure F.1-1: EVM measurement points

### F.2 Basic Error Vector Magnitude measurement

The EVM is the difference between the ideal waveform and the measured waveform for the allocated RB(s)

$$EVM = \sqrt{\frac{\sum_{v \in T_m} |z'(v) - i(v)|^2}{|T_m| \cdot P_0}}$$

where

$T_m$  is a set of  $|T_m|$  modulation symbols with the considered modulation scheme being active within the measurement period,

$z'(v)$  are the samples of the signal evaluated for the EVM,

$i(v)$  is the ideal signal reconstructed by the measurement equipment, and

$P_0$  is the average power of the ideal signal. For normalized modulation symbols  $P_0$  is equal to 1.

The basic EVM measurement interval is defined over one slot in the time domain for PUCCH and PUSCH and over one preamble sequence for the PRACH.

### F.3 Basic in-band emissions measurement

The in-band emissions are a measure of the interference falling into the non-allocated resources blocks. The in-band emission requirement is evaluated for PUCCH and PUSCH transmissions. The in-band emission requirement is not evaluated for PRACH transmissions.

The in-band emissions are measured as follows

$$Emissions_{absolute}(\Delta_{RB}) = \begin{cases} \frac{1}{|T_s|} \int_{t \in T_s} \int_{f_i + (12 \cdot \Delta_{RB} + 1) \Delta f}^{\max(f_{\min}, f_i + 12 \cdot \Delta_{RB} \cdot \Delta f)} |Y(t, f)|^2, \Delta_{RB} < 0 \\ \frac{1}{|T_s|} \int_{t \in T_s} \int_{f_h + (12 \cdot \Delta_{RB} - 1) \Delta f}^{\min(f_{\max}, f_h + 12 \cdot \Delta_{RB} \cdot \Delta f)} |Y(t, f)|^2, \Delta_{RB} > 0 \end{cases},$$

where

$T_s$  is a set of  $|T_s|$  SC-FDMA symbols with the considered modulation scheme being active within the measurement period,

$\Delta_{RB}$  is the starting frequency offset between the allocated RB and the measured non-allocated RB (e.g.  $\Delta_{RB} = 1$  or  $\Delta_{RB} = -1$  for the first adjacent RB),

$f_{\min}$  (resp.  $f_{\max}$ ) is the lower (resp. upper) edge of the UL system BW,

$f_l$  and  $f_h$  are the lower and upper edge of the allocated BW, and

$Y(t, f)$  is the frequency domain signal evaluated for in-band emissions as defined in the subsection (ii)

The relative in-band emissions are, given by

$$Emissions_{relative}(\Delta_{RB}) = \frac{Emissions_{absolute}(\Delta_{RB})}{\frac{1}{|T_s| \cdot N_{RB}} \int_{t \in T_s} \int_{f_l}^{f_i + (12 \cdot N_{RB} - 1) \Delta f} |Y(t, f)|^2}$$

where

$N_{RB}$  is the number of allocated RBs

The basic in-band emissions measurement interval is defined over one slot in the time domain. When the PUSCH or PUCCH transmission slot is shortened due to multiplexing with SRS, the in-band emissions measurement interval is reduced by one SC-FDMA symbol, accordingly.

In the evaluation of in-band emissions, the timing is set according to  $\Delta \tilde{t} = \Delta \tilde{C}$ , where sample time offsets  $\Delta \tilde{t}$  and  $\Delta \tilde{C}$  are defined in subclause F.4.

### F.4 Modified signal under test

Implicit in the definition of EVM is an assumption that the receiver is able to compensate a number of transmitter impairments.

The PUSCH data or PRACH or Physical Sidelink Channel signal under test is modified and, in the case of PUSCH or Physical Sidelink Channel data signal, decoded according to:

$$Z'(t, f) = IDFT \left\{ \frac{FFT \left\{ z(v - \Delta\tilde{t}) \cdot e^{-j2\pi\tilde{f}v} \right\} e^{j2\pi\tilde{f}\Delta\tilde{t}}}{\tilde{a}(t, f) \cdot e^{j\tilde{\varphi}(t, f)}} \right\}$$

where

$z(v)$  is the time domain samples of the signal under test.

The PUCCH or PUSCH or Physical Sidelink Channel demodulation reference signal or PUCCH data signal under test is equalised and, in the case of PUCCH data signal decoded according to:

$$Z'(t, f) = \frac{FFT \left\{ z(v - \Delta\tilde{t}) \cdot e^{-j2\pi\tilde{f}v} \right\} e^{j2\pi\tilde{f}\Delta\tilde{t}}}{\tilde{a}(t, f) \cdot e^{j\tilde{\varphi}(t, f)}}$$

where

$z(v)$  is the time domain samples of the signal under test.

To minimize the error, the signal under test should be modified with respect to a set of parameters following the procedure explained below.

Notation:

$\Delta\tilde{t}$  is the sample timing difference between the FFT processing window in relation to nominal timing of the ideal signal.

$\Delta\tilde{f}$  is the RF frequency offset.

$\tilde{\varphi}(t, f)$  is the phase response of the TX chain.

$\tilde{a}(t, f)$  is the amplitude response of the TX chain.

In the following  $\Delta\tilde{c}$  represents the middle sample of the EVM window of length  $W$  (defined in the next subsections) or the last sample of the first window half if  $W$  is even.

The EVM analyser shall

- detect the start of each slot and estimate  $\Delta\tilde{t}$  and  $\Delta\tilde{f}$ ,
- determine  $\Delta\tilde{c}$  so that the EVM window of length  $W$  is centred
  - on the time interval determined by the measured cyclic prefix minus 16 samples of the considered OFDM symbol for symbol 0 for normal CP, i.e. the first 16 samples of the CP should not be taken into account for this step. In the determination of the number of excluded samples, a sampling rate of 30.72MHz was assumed. If a different sampling rate is used, the number of excluded samples is scaled linearly.
  - on the measured cyclic prefix of the considered OFDM symbol symbol for symbol 1 to 6 for normal CP and for symbol 0 to 5 for extended CP.
  - on the measured preamble cyclic prefix for the PRACH

To determine the other parameters a sample timing offset equal to  $\Delta\tilde{c}$  is corrected from the signal under test. The EVM analyser shall then

- correct the RF frequency offset  $\Delta\tilde{f}$  for each time slot, and
- apply an FFT of appropriate size. The chosen FFT size shall ensure that in the case of an ideal signal under test, there is no measured inter-subcarrier interference.

The carrier leakage shall be removed from the evaluated signal before calculating the EVM and the in-band emissions; however, the removed relative carrier leakage power also has to satisfy the applicable requirement.

At this stage the allocated RBs shall be separated from the non-allocated RBs. In the case of PUCCH and PUSCH EVM, the signal on the non-allocated RB(s),  $Y(t, f)$ , is used to evaluate the in-band emissions.

Moreover, the following procedure applies only to the signal on the allocated RB(s).

- In the case of PUCCH and PUSCH and Physical Sidelink Channel, the UL EVM analyzer shall estimate the TX chain equalizer coefficients  $\tilde{a}(t, f)$  and  $\tilde{\varphi}(t, f)$  used by the ZF equalizer for all subcarriers by time averaging at each signal subcarrier of the amplitude and phase of the reference and data symbols. The time-averaging length is 1 slot. This process creates an average amplitude and phase for each signal subcarrier used by the ZF equalizer. The knowledge of data modulation symbols may be required in this step because the determination of symbols by demodulation is not reliable before signal equalization.
- In the case of PRACH, the UL EVM analyzer shall estimate the TX chain coefficients  $\tilde{a}(t)$  and  $\tilde{\varphi}(t)$  used for phase and amplitude correction and are selected so as to minimize the resulting EVM. The TX chain coefficients are not dependent on frequency, i.e.  $\tilde{a}(t, f) = \tilde{a}(t)$  and  $\tilde{\varphi}(t, f) = \tilde{\varphi}(t)$ . The TX chain coefficient are chosen independently for each preamble transmission and for each  $\Delta\tilde{t}$ .

At this stage estimates of  $\Delta\tilde{f}$ ,  $\tilde{a}(t, f)$ ,  $\tilde{\varphi}(t, f)$  and  $\Delta\tilde{c}$  are available.  $\Delta\tilde{t}$  is one of the extremities of the window  $W$ , i.e.  $\Delta\tilde{t}$  can be  $\Delta\tilde{c} + \alpha - \left\lfloor \frac{W}{2} \right\rfloor$  or  $\Delta\tilde{c} + \left\lfloor \frac{W}{2} \right\rfloor$ , where  $\alpha = 0$  if  $W$  is odd and  $\alpha = 1$  if  $W$  is even. The EVM analyser shall then

- calculate EVM<sub>l</sub> with  $\Delta\tilde{t}$  set to  $\Delta\tilde{c} + \alpha - \left\lfloor \frac{W}{2} \right\rfloor$ ,
- calculate EVM<sub>h</sub> with  $\Delta\tilde{t}$  set to  $\Delta\tilde{c} + \left\lfloor \frac{W}{2} \right\rfloor$ .

---

## F.5 Window length

### F.5.1 Timing offset

As a result of using a cyclic prefix, there is a range of  $\Delta\tilde{t}$ , which, at least in the case of perfect Tx signal quality, would give close to minimum error vector magnitude. As a first order approximation, that range should be equal to the length of the cyclic prefix. Any time domain windowing or FIR pulse shaping applied by the transmitter reduces the  $\Delta\tilde{t}$  range within which the error vector is close to its minimum.

### F.5.2 Window length

The window length  $W$  affects the measured EVM, and is expressed as a function of the configured cyclic prefix length. In the case where equalization is present, as with frequency domain EVM computation, the effect of FIR is reduced. This is because the equalization can correct most of the linear distortion introduced by the FIR. However, the time domain windowing effect can't be removed.

### F.5.3 Window length for normal CP

The table below specifies the EVM window length at channel bandwidths 1.4, 3, 5, 10, 15, 20 MHz, for normal CP. The nominal window length for 3 MHz is rounded down one sample to allow the window to be centered on the symbol.

Table F.5.3-1 EVM window length for normal CP

Channel Bandwidth MHz	Cyclic prefix length <sup>1</sup> $N_{cp}$ for symbol 0	Cyclic prefix length <sup>1</sup> $N_{cp}$ for symbols 1 to 6	Nominal FFT size	Cyclic prefix for symbols 1 to 6 in FFT samples	EVM window length $W$ in FFT samples	Ratio of $W$ to CP for symbols 1 to 6 <sup>2</sup>
1.4	160	144	128	9	5	55.6
3			256	18	12	66.7
5			512	36	32	88.9
10			1024	72	66	91.7
15			1536	108	102	94.4
20			2048	144	136	94.4

Note 1: The unit is number of samples, sampling rate of 30.72MHz is assumed.  
Note 2: These percentages are informative and apply to symbols 1 through 6. Symbol 0 has a longer CP and therefore a lower percentage.

## F.5.4 Window length for Extended CP

The table below specifies the EVM window length at channel bandwidths 1.4, 3, 5, 10, 15, 20 MHz, for extended CP. The nominal window lengths for 3 MHz and 15 MHz are rounded down one sample to allow the window to be centered on the symbol.

Table F.5.4-1 EVM window length for extended CP

Channel Bandwidth MHz	Cyclic prefix length <sup>1</sup> $N_{cp}$	Nominal FFT size	Cyclic prefix in FFT samples	EVM window length $W$ in FFT samples	Ratio of $W$ to CP <sup>2</sup>
1.4	512	128	32	28	87.5
3		256	64	58	90.6
5		512	128	124	96.9
10		1024	256	250	97.4
15		1536	384	374	97.4
20		2048	512	504	98.4

Note 1: The unit is number of samples, sampling rate of 30.72MHz is assumed.  
Note 2: These percentages are informative

## F.5.5 Window length for PRACH

The table below specifies the EVM window length for PRACH preamble formats 0-4.

Table F.5.5-1 EVM window length for PRACH

Preamble format	Cyclic prefix length <sup>1</sup> $N_{cp}$	Nominal FFT size <sup>2</sup>	EVM window length $W$ in FFT samples	Ratio of $W$ to CP <sup>3</sup>
0	3168	24576	3072	96.7%
1	21024	24576	20928	99.5%
2	6240	49152	6144	98.5%
3	21024	49152	20928	99.5%
4	448	4096	432	96.4%

Note 1: The unit is number of samples, sampling rate of 30.72MHz is assumed  
Note 2: The use of other FFT sizes is possible as long as appropriate scaling of the window length is applied  
Note 3: These percentages are informative

## F.5.F Window length for category NB1

The EVM window length,  $W$ , for NPUSCH is set to 1 (in FFT samples where the nominal FFT size is 128 for 15 kHz sub-carrier spacing and 512 for 3.75 kHz sub-carrier spacing).

The EVM window length,  $W$ , for NPRACH is set to 110 for preamble format 0 and to 494 for preamble format 1 (both in FFT samples where the nominal FFT size is 512).

---

## F.6 Averaged EVM

The general EVM is averaged over basic EVM measurements for  $n$  slots in the time domain.

$$\overline{EVM} = \sqrt{\frac{1}{n} \sum_{i=1}^n EVM_i^2},$$

where  $n$  is

$n = 20$  for PUCCH, PUSCH, PSDCH, PSCCH, and PSSCH,

$n = 48$  for PBSCCH.

The EVM requirements shall be tested against the maximum of the RMS average at the window  $W$  extremities of the EVM measurements:

Thus  $\overline{EVM}_l$  is calculated using  $\Delta\tilde{t} = \Delta\tilde{t}_l$  in the expressions above and  $\overline{EVM}_h$  is calculated using  $\Delta\tilde{t} = \Delta\tilde{t}_h$ .

Thus we get:

$$EVM = \max(\overline{EVM}_l, \overline{EVM}_h)$$

The calculation of the EVM for the demodulation reference signal,  $EVM_{DMRS}$ , follows the same procedure as calculating the general EVM, with the exception that the modulation symbol set  $T_m$  defined in clause F.2 is restricted to symbols containing uplink demodulation reference signals.

The basic  $EVM_{DMRS}$  measurements are first averaged over 20 slots in the time domain to obtain an intermediate average  $\overline{EVM}_{DMRS}$ .

$$\overline{EVM}_{DMRS} = \sqrt{\frac{1}{20} \sum_{i=1}^{20} EVM_{DMRS,i}^2}$$

In the determination of each  $EVM_{DMRS,i}$ , the timing is set to  $\Delta\tilde{t} = \Delta\tilde{t}_l$  if  $\overline{EVM}_l > \overline{EVM}_h$ , and it is set to  $\Delta\tilde{t} = \Delta\tilde{t}_h$  otherwise, where  $\overline{EVM}_l$  and  $\overline{EVM}_h$  are the general average EVM values calculated in the same 20 slots over which the intermediate average  $\overline{EVM}_{DMRS}$  is calculated. Note that in some cases, the general average EVM may be calculated only for the purpose of timing selection for the demodulation reference signal EVM.

Then the results are further averaged to get the EVM for the demodulation reference signal,  $EVM_{DMRS}$ ,

$$EVM_{DMRS} = \sqrt{\frac{1}{6} \sum_{j=1}^6 \overline{EVM}_{DMRS,j}^2}$$

The PRACH EVM,  $EVM_{PRACH}$ , is averaged over two preamble sequence measurements for preamble formats 0, 1, 2, 3, and it is averaged over 10 preamble sequence measurements for preamble format 4.

The EVM requirements shall be tested against the maximum of the RMS average at the window  $W$  extremities of the EVM measurements:

Thus  $\overline{EVM}_{\text{PRACH,l}}$  is calculated using  $\Delta\tilde{t} = \Delta\tilde{t}_l$  and  $\overline{EVM}_{\text{PRACH,h}}$  is calculated using  $\Delta\tilde{t} = \Delta\tilde{t}_h$ .

Thus we get:

$$EVM_{\text{PRACH}} = \max(\overline{EVM}_{\text{PRACH,l}}, \overline{EVM}_{\text{PRACH,h}})$$

### F.6.F Averaged EVM for category NB1

The general EVM for category NB1 is calculated using the procedure defined in Annex F.6 with the exception that the general EVM is averaged over basic EVM measurements for  $240/L_{\text{Ctone}}$  slots in the time domain, where  $L_{\text{Ctone}} = \{1, 3, 6, 12\}$  is the number of subcarriers for the transmission.

The calculation of the EVM for the demodulation reference symbols for category NB1 follows the procedure defined for DMRS in Annex F.6 with the exception that the basic  $EVM_{\text{DMRS}}$  measurements are first averaged over  $240/L_{\text{Ctone}}$  slots to obtain the intermediate average EVM.

The calculation of the NPRACH EVM for both formats follows the procedure defined for PRACH in Annex F.6 with the exception that  $EVM_{\text{PRACH}}$  is averaged over 64 preamble measurements.

---

## F.7 Spectrum Flatness

The data shall be taken from FFT coded data symbols and the demodulation reference symbols of the allocated resource block.

---

## Annex G (informative): Reference sensitivity level in lower SNR

This annex contains information on typical receiver sensitivity when HARQ transmission is enabled allowing operation in lower SNR regions (HARQ is disabled in conformance testing), thus representing the configuration normally used in live network operation under noise-limited conditions.

---

### G.1 General

The reference sensitivity power level  $P_{\text{SENS}}$  with HARQ retransmission enabled (operation in lower SNR) is the minimum mean power applied to both the UE antenna ports at which the residual BLER after HARQ shall meet the requirements for the specified reference measurement channel. The residual BLER after HARQ transmission is defined as follows:

$$BLER_{\text{residual}} = 1 - \frac{A}{B}$$

$A$  : Number of correctly decoded MAC PDUs

$B$  : Number of transmitted MAC PDUs (Retransmitted MAC PDUs are not counted)

---

### G.2 Typical receiver sensitivity performance (QPSK)

The residual BLER after HARQ shall be lower than 1% for the reference measurement channels as specified in Annexes G.3 (with one sided dynamic OCNG Pattern OP.1 FDD/TDD for the DL-signal as described in Annex A.5.1.1/A.5.2.1) with parameters specified in Table G.2-1 and Table G.2-2



**Table G.2-1: Reference sensitivity QPSK  $P_{\text{SENS}}$**

Channel bandwidth							
E-UTRA Band	1.4 MHz (dBm)	3 MHz (dBm)	5 MHz (dBm)	10 MHz (dBm)	15 MHz (dBm)	20 MHz (dBm)	Duplex Mode
1				[-102]			FDD
2				TBD			FDD
3				TBD			FDD
4				TBD			FDD
5				TBD			FDD
6				TBD			FDD
7				TBD			FDD
8				TBD			FDD
9				TBD			FDD
10				TBD			FDD
11				TBD			FDD
12				TBD			FDD
13				TBD			FDD
14				TBD			FDD
...							
17				TBD			FDD
18				TBD			FDD
19				TBD			FDD
20				TBD			FDD
21				TBD			FDD
22				TBD			FDD
23				TBD			FDD
26				TBD			FDD
27				TBD			FDD
28				TBD			FDD
30				TBD			FDD
31			TBD				FDD
...							
33				[-102]			TDD
34				[-102]			TDD
35				[-102]			TDD
36				[-102]			TDD
37				[-102]			TDD
38				[-102]			TDD
39				[-102]			TDD
40				[-102]			TDD
42				[-102]			TDD
43				[-102]			TDD
44				[-102]			TDD
45				[-102]			TDD
...							
65				TBD			FDD
70				TBD			FDD
71				TBD			FDD
87			TBD				FDD
88			TBD				FDD

Note 1:	The transmitter shall be set to $P_{\text{UMAX}}$ as defined in clause 6.2.5
Note 2:	Reference measurement channel is G.3 with one sided dynamic OCNG Pattern OP.1 FDD/TDD as described in Annex A.5.1.1/A.5.2.1
Note 3:	The signal power is specified per port
Note 4:	For the UE which supports both Band 3 and Band 9 the reference sensitivity level is FFS.
Note 5:	For the UE which supports both Band 11 and Band 21 the reference sensitivity level is FFS.

Table G.2-2 specifies the minimum number of allocated uplink resource blocks for which the reference receive sensitivity requirement in lower SNR must be met.

**Table G.2-2: Minimum uplink configuration for reference sensitivity**

E-UTRA Band / Channel bandwidth / NRB / Duplex mode							
E-UTRA Band	1.4 MHz	3 MHz	5 MHz	10 MHz	15 MHz	20 MHz	Duplex Mode
1				[6] <sup>1</sup>			FDD
2				[6] <sup>1</sup>			FDD
3				[6] <sup>1</sup>			FDD
4				[6] <sup>1</sup>			FDD
5				[6] <sup>1</sup>			FDD
6				[6] <sup>1</sup>			FDD
7				[6] <sup>1</sup>			FDD
8				[6] <sup>1</sup>			FDD
9				[6] <sup>1</sup>			FDD
10				[6] <sup>1</sup>			FDD
11				[6] <sup>1</sup>			FDD
12				[6] <sup>1</sup>			FDD
13				[6] <sup>1</sup>			FDD
14				[6] <sup>1</sup>			FDD
...							
17				[6] <sup>1</sup>			FDD
18				[6] <sup>1</sup>			FDD
19				[6] <sup>1</sup>			FDD
20				[6] <sup>1</sup>			FDD
22				[6] <sup>1</sup>			FDD
21				[6] <sup>1</sup>			FDD
23				[6] <sup>1</sup>			FDD
26				[6] <sup>1</sup>			FDD
27				[6] <sup>1</sup>			FDD
28				[6] <sup>1</sup>			FDD
30				[6] <sup>1</sup>			FDD
31			[5] <sup>4</sup>				FDD
...							
33				50			TDD
34				50			TDD
35				50			TDD
36				50			TDD
37				50			TDD
38				50			TDD
39				50			TDD
40				50			TDD
42				50			TDD
43				50			TDD
44				50			TDD
45				50			TDD
...							
65				[6] <sup>1</sup>			FDD
...							
70				[6] <sup>1</sup>			FDD
71				[6] <sup>1</sup>			FDD
87			[5] <sup>4</sup>				FDD
88			[5] <sup>4</sup>				FDD

Note 1:	The UL resource blocks shall be located as close as possible to the downlink operating band but confined within the transmission bandwidth configuration for the channel bandwidth (Table 5.6-1).
Note 2:	For the UE which supports both Band 11 and Band 21 the minimum uplink configuration for reference sensitivity is FFS.
Note 3:	For Band 20; in the case of 15MHz channel bandwidth, the UL resource blocks shall be located at RBstart _11 and in the case of 20MHz channel bandwidth, the UL resource blocks shall be located at RBstart _16
Note 4:	For Band 31, 87, 88; in the case of 5MHz channel bandwidth, the UL resource blocks shall be located at RBstart _10

Unless given by Table G.2-3, the minimum requirements specified in Tables G.2-1 and G.2-2 shall be verified with the network signalling value NS\_01 (Table 6.2.4-1) configured.

**Table G.2-3: Network Signalling Value for reference sensitivity**

Network Signalling value	E-UTRA Band
NS_03	2, 4, 10, 23, 35, 36, 70
NS_06	12,13,14,17
NS_08	19
NS_09	21
NS_21	30
NS_35	71

---

## G.3 Reference measurement channel for REFSENSE in lower SNR

Tables G.3-1 and G.3-2 are applicable for Annex G.2 (Reference sensitivity level in lower SNR).

Table G.3-1 Fixed Reference Channel for Receiver Requirements (FDD)

Parameter	Unit	Value	
		5	10
Channel bandwidth	MHz	5	10
Allocated resource blocks		25	50
Subcarriers per resource block		12	12
Allocated subframes per Radio Frame		9	9
Modulation		QPSK	QPSK
Target Coding Rate		1/3	1/3
Number of HARQ Processes	Processes	8	8
Maximum number of HARQ transmissions		[4]	[4]
Information Bit Payload per Sub-Frame			
For Sub-Frames 1,2,3,4,6,7,8,9	Bits	2216	4392
For Sub-Frame 5	Bits	N/A	N/A
For Sub-Frame 0	Bits	1800	4392
Transport block CRC	Bits	24	24
Number of Code Blocks per Sub-Frame (Note 4)			
For Sub-Frames 1,2,3,4,6,7,8,9	Bits	1	1
For Sub-Frame 5	Bits	N/A	N/A
For Sub-Frame 0	Bits	1	1
Binary Channel Bits Per Sub-Frame			
For Sub-Frames 1,2,3,4,6,7,8,9	Bits	6300	13800
For Sub-Frame 5	Bits	N/A	N/A
For Sub-Frame 0	Bits	5460	12960
Max. Throughput averaged over 1 frame	kbps	1952.	3952.
		8	8
UE Category		1-8	1-8
Note 1:	2 symbols allocated to PDCCH for 20 MHz, 15 MHz and 10MHz channel BW. 3 symbols allocated to PDCCH for 5 MHz and 3 MHz. 4 symbols allocated to PDCCH for 1.4 MHz		
Note 2:	Reference signal, Synchronization signals and PBCH allocated as per TS 36.211 [4]		
Note 3:	If more than one Code Block is present, an additional CRC sequence of L = 24 Bits is attached to each Code Block (otherwise L = 0 Bit)		
Note 4:	Redundancy version coding sequence is {0, 1, 2, 3} for QPSK.		

Table G.3-2 Fixed Reference Channel for Receiver Requirements (TDD)

Parameter	Unit	Value			
Channel Bandwidth	MHz			10	
Allocated resource blocks				50	
Uplink-Downlink Configuration (Note 5)				1	
Allocated subframes per Radio Frame (D+S)				4+2	
Number of HARQ Processes	Processes			7	
Maximum number of HARQ transmission				[4]	
Modulation				QPSK	
Target coding rate				1/3	
Information Bit Payload per Sub-Frame	Bits				
For Sub-Frame 4, 9				4392	
For Sub-Frame 1, 6				3240	
For Sub-Frame 5				N/A	
For Sub-Frame 0				4392	
Transport block CRC	Bits			24	
Number of Code Blocks per Sub-Frame (Note 5)					
For Sub-Frame 4, 9				1	
For Sub-Frame 1, 6				1	
For Sub-Frame 5				N/A	
For Sub-Frame 0				1	
Binary Channel Bits Per Sub-Frame	Bits				
For Sub-Frame 4, 9				13800	
For Sub-Frame 1, 6				11256	
For Sub-Frame 5				N/A	
For Sub-Frame 0				13104	
Max. Throughput averaged over 1 frame	kbps			1965.6	
UE Category				1-5	
Note 1:	For normal subframes(0,4,5,9), 2 symbols allocated to PDCCH for 20 MHz, 15 MHz and 10 MHz channel BW; 3 symbols allocated to PDCCH for 5 MHz and 3 MHz; 4 symbols allocated to PDCCH for 1.4 MHz. For special subframe (1&6), only 2 OFDM symbols are allocated to PDCCH for all BWs.				
Note 2:	For 1.4MHz, no data shall be scheduled on special subframes(1&6) to avoid problems with insufficient PDCCH performance				
Note 3:	Reference signal, Synchronization signals and PBCH allocated as per TS 36.211 [4]				
Note 4:	If more than one Code Block is present, an additional CRC sequence of L = 24 Bits is attached to each Code Block (otherwise L = 0 Bit).				
Note 5:	As per Table 4.2-2 in TS 36.211 [4]				
Note 6:	Redundancy version coding sequence is {0, 1, 2, 3} for QPSK.				



## Annex H (normative): Modified MPR behavior

### H.1 Indication of modified MPR behavior

This annex contains the definitions of the bits in the field *modifiedMPRbehavior* indicated in the IE UE Radio Access Capability [7] by a UE supporting an MPR or A-MPR modified in a later release of this specification.

**Table H.1-1: Definitions of the bits in the field *modifiedMPRbehavior***

Index of field (bit number)	Definition (description of the supported functionality if indicator set to one)	Notes
0 (leftmost bit)	- The MPR for intra-band contiguous carrier aggregation bandwidth class C with non-contiguous resource allocation specified in Clause 6.2.3A in version 12.5.0 of this specification	- This bit shall be set to 1 by a UE supporting intra-band contiguous CA bandwidth class C
1	- The A-MPR associated with NS_05 for Band 1 in Clause 6.2.4 in version 12.10.0 of this specification.	- This bit shall be set to 1 by a UE supporting A-MPR associated to NS_05 for Band 1.
2	The A-MPR associated with NS_04 for Band 41 in Table 6.2.4-4 in version 14.1.0 of this specification.	- This bit shall be set to 1 by a power class 3 UE supporting A-MPR associated to NS_04 for Band 41.
3	The A-MPR associated with NS_31 for Band 46 in Table 6.2.4-26 in version 15.3.0 of this specification.	- This bit shall be set to 1 by a UE supporting A-MPR associated to NS_31 for Band 46.

---

## Annex I (normative): Supported Post Antenna Gain

### I.1 Declared Supported Post Antenna Gain for UE

For V2X service at band 47, some regional requirements (region 1) are defined per effective isotropic radiated power (EIRP), which is a combination of the transmitted power (or in some cases spectral density) and the effective antenna gain.

Due to large form factor, V2X UE can have external antenna placed far away from the chipset unit. In this case, the effective antenna gain is a UE specific condition. This effective antenna gain includes the feeding loss of all components after the chipset unit antenna connector and the peak directional gain of the external antenna and hence will be call the post connector gain  $G_{\text{post connector}}$ .

The 3GPP specifications mandate UE manufacturer declarations of at least one supported value of the post connector gain  $G_{\text{post connector}}$  as a way to accommodate the refered regional requirement without putting requirements on the UE specific condition.

The possible values of declared supported post connector gains are: 0, 1, 2, 3, 4, 5, 6, 7 dBi. If no value is declared, or if external antenna is not used, the default value of 0dBi will be used.

The regional requirements in  $P_{\text{EIRP}}$  in Subclauses 6.2.2G, 6.2.5G, 6.6.2.2.4, 6.6.3.2 and 7.9.1 will be converted to conducted requirements by subtracting  $G_{\text{post connector}}$  as:

$$P_{\text{Conducted}} = P_{\text{EIRP}} - G_{\text{post connector}}$$

## Annex J (informative): Change history

**Table J.1: Change History**

Date	Meeting	TDoc	CR	Rev	Ca t	Subject/Comment	New version
11-2007	R4#45	R4-72206				TS36.101V0.1.0 approved by RAN4	
12-2007	RP#38	RP-070979				Approved version at TSG RAN #38	8.0.0
03-2008	RP#39	RP-080123	3			TS36.101 - Combined updates of E-UTRA UE requirements	8.1.0
05-2008	RP#40	RP-080325	4			TS36.101 - Combined updates of E-UTRA UE requirements	8.2.0
09-2008	RP#41	RP-080638	5r1			Addition of Ref Sens figures for 1.4MHz and 3MHz Channel bandwidths	8.3.0
09-2008	RP#41	RP-080638	7r1			Transmitter intermodulation requirements	8.3.0
09-2008	RP#41	RP-080638	10			CR for clarification of additional spurious emission requirement	8.3.0
09-2008	RP#41	RP-080638	15			Correction of In-band Blocking Requirement	8.3.0
09-2008	RP#41	RP-080638	18r1			TS36.101: CR for section 6: NS_06	8.3.0
09-2008	RP#41	RP-080638	19r1			TS36.101: CR for section 6: Tx modulation	8.3.0
09-2008	RP#41	RP-080638	20r1			TS36.101: CR for UE minimum power	8.3.0
09-2008	RP#41	RP-080638	21r1			TS36.101: CR for UE OFF power	8.3.0
09-2008	RP#41	RP-080638	24r1			TS36.101: CR for section 7: Band 13 Rx sensitivity	8.3.0
09-2008	RP#41	RP-080638	26			UE EVM Windowing	8.3.0
09-2008	RP#41	RP-080638	29			Absolute ACLR limit	8.3.0
09-2008	RP#41	RP-080731	23r2			TS36.101: CR for section 6: UE to UE co-existence	8.3.0
09-2008	RP#41	RP-080731	30			Removal of [ ] for UE Ref Sens figures	8.3.0
09-2008	RP#41	RP-080731	31			Correction of PA, PB definition to align with RAN1 specification	8.3.0
09-2008	RP#41	RP-080731	37r2			UE Spurious emission band UE co-existence	8.3.0
09-2008	RP#41	RP-080731	44			Definition of specified bandwidths	8.3.0
09-2008	RP#41	RP-080731	48r3			Addition of Band 17	8.3.0
09-2008	RP#41	RP-080731	50			Alignment of the UE ACS requirement	8.3.0
09-2008	RP#41	RP-080731	52r1			Frequency range for Band 12	8.3.0
09-2008	RP#41	RP-080731	54r1			Absolute power tolerance for LTE UE power control	8.3.0
09-2008	RP#41	RP-080731	55			TS36.101 section 6: Tx modulation	8.3.0
09-2008	RP#41	RP-080732	6r2			DL FRC definition for UE Receiver tests	8.3.0
09-2008	RP#41	RP-080732	46			Additional UE demodulation test cases	8.3.0
09-2008	RP#41	RP-080732	47			Updated descriptions of FRC	8.3.0
09-2008	RP#41	RP-080732	49			Definition of UE transmission gap	8.3.0
09-2008	RP#41	RP-080732	51			Clarification on High Speed train model in 36.101	8.3.0
09-2008	RP#41	RP-080732	53			Update of symbol and definitions	8.3.0
09-2008	RP#41	RP-080743	56			Addition of MIMO (4x2) and (4x4) Correlation Matrices	8.3.0
12-2008	RP#42	RP-080908	94r2			CR TX RX channel frequency separation	8.4.0
12-2008	RP#42	RP-080909	105r1			UE Maximum output power for Band 13	8.4.0
12-2008	RP#42	RP-080909	60			UL EVM equalizer definition	8.4.0
12-2008	RP#42	RP-080909	63			Correction of UE spurious emissions	8.4.0
12-2008	RP#42	RP-080909	66			Clarification for UE additional spurious emissions	8.4.0
12-2008	RP#42	RP-080909	72			Introducing ACLR requirement for coexistence with UTRA 1.6MHz channel from 36.803	8.4.0
12-2008	RP#42	RP-080909	75			Removal of [ ] from Section 6 transmitter characteristics	8.4.0
12-2008	RP#42	RP-080909	81			Clarification for PHS band protection	8.4.0
12-2008	RP#42	RP-080909	101			Alignment for the measurement interval for transmit signal quality	8.4.0
12-2008	RP#42	RP-080909	98r1			Maximum power	8.4.0
12-2008	RP#42	RP-080909	57r1			CR UE spectrum flatness	8.4.0
12-2008	RP#42	RP-080909	71r1			UE in-band emission	8.4.0
12-2008	RP#42	RP-080909	58r1			CR Number of TX exceptions	8.4.0
12-2008	RP#42	RP-080951	99r2			CR UE output power dynamic	8.4.0
12-2008	RP#42	RP-080951	79r1			LTE UE transmitter intermodulation	8.4.0
12-2008	RP#42	RP-080910	91			Update of Clause 8	8.4.0
12-2008	RP#42	RP-080950	106r1			Structure of Clause 9 including CSI requirements for PUCCH mode 1-0	8.4.0
12-2008	RP#42	RP-080911	59			CR UE ACS test frequency offset	8.4.0
12-2008	RP#42	RP-080911	65			Correction of spurious response parameters	8.4.0
12-2008	RP#42	RP-080911	80			Removal of LTE UE narrowband intermodulation	8.4.0
12-2008	RP#42	RP-080911	90r1			Introduction of Maximum Sensitivity Degradation	8.4.0
12-2008	RP#42	RP-080911	103			Removal of [ ] from Section 7 Receiver characteristic	8.4.0
12-2008	RP#42	RP-080912	62			Alignment of TB size n Ref Meas channel for RX characteristics	8.4.0
12-2008	RP#42	RP-080912	78			TDD Reference Measurement channel for RX characteristics	8.4.0
12-2008	RP#42	RP-080912	73r1			Addition of 64QAM DL referenbce measurement channel	8.4.0

12-2008	RP#42	RP-080912	74r1		Addition of UL Reference Measurement Channels	8.4.0
12-2008	RP#42	RP-080912	104		Reference measurement channels for PDSCH performance requirements (TDD)	8.4.0
12-2008	RP#42	RP-080913	68		MIMO Correlation Matrix Corrections	8.4.0
12-2008	RP#42	RP-080915	67		Correction to the figure with the Transmission Bandwidth configuration	8.4.0
12-2008	RP#42	RP-080916	77		Modification to EARFCN	8.4.0
12-2008	RP#42	RP-080917	85r1		New Clause 5 outline	8.4.0
12-2008	RP#42	RP-080919	102		Introduction of Bands 12 and 17 in 36.101	8.4.0
12-2008	RP#42	RP-080927	84r1		Clarification of HST propagation conditions	8.4.0
03-2009	RP#43	RP-090170	156r2		A-MPR table for NS_07	8.5.0
03-2009	RP#43	RP-090170	170		Corrections of references (References to tables and figures)	8.5.0
03-2009	RP#43	RP-090170	108		Removal of [ ] from Transmitter Intermodulation	8.5.0
03-2009	RP#43	RP-090170	155		E-UTRA ACLR for below 5 MHz bandwidths	8.5.0
03-2009	RP#43	RP-090170	116		Clarification of PHS band including the future plan	8.5.0
03-2009	RP#43	RP-090170	119		Spectrum emission mask for 1.4 MHz and 3 MHz bandwidths	8.5.0
03-2009	RP#43	RP-090170	120		Removal of "Out-of-synchronization handling of output power" heading	8.5.0
03-2009	RP#43	RP-090170	126		UE uplink power control	8.5.0
03-2009	RP#43	RP-090170	128		Transmission BW Configuration	8.5.0
03-2009	RP#43	RP-090170	130		Spectrum flatness	8.5.0
03-2009	RP#43	RP-090170	132r2		PUCCH EVM	8.5.0
03-2009	RP#43	RP-090170	134		UL DM-RS EVM	8.5.0
03-2009	RP#43	RP-090170	140		Removal of ACLR2bis requirements	8.5.0
03-2009	RP#43	RP-090171	113		In-band blocking	8.5.0
03-2009	RP#43	RP-090171	127		In-band blocking and sensitivity requirement for band 17	8.5.0
03-2009	RP#43	RP-090171	137r1		Wide band intermodulation	8.5.0
03-2009	RP#43	RP-090171	141		Correction of reference sensitivity power level of Band 9	8.5.0
03-2009	RP#43	RP-090172	109		AWGN level for UE DL demodulation performance tests	8.5.0
03-2009	RP#43	RP-090172	124		Update of Clause 8: additional test cases	8.5.0
03-2009	RP#43	RP-090172	139r1		Performance requirement structure for TDD PDSCH	8.5.0
03-2009	RP#43	RP-090172	142r1		Performance requirements and reference measurement channels for TDD PDSCH demodulation with UE-specific reference symbols	8.5.0
03-2009	RP#43	RP-090172	145		Number of information bits in DwPTS	8.5.0
03-2009	RP#43	RP-090172	160r1		MBSFN-Unicast demodulation test case	8.5.0
03-2009	RP#43	RP-090172	163r1		MBSFN-Unicast demodulation test case for TDD	8.5.0
03-2009	RP#43	RP-090173	162		Clarification of EARFCN for 36.101	8.5.0
03-2009	RP#43	RP-090369	110		Correction to UL Reference Measurement Channel	8.5.0
03-2009	RP#43	RP-090369	114		Addition of MIMO (4x4, medium) Correlation Matrix	8.5.0
03-2009	RP#43	RP-090369	121		Correction of 36.101 DL RMC table notes	8.5.0
03-2009	RP#43	RP-090369	125		Update of Clause 9	8.5.0
03-2009	RP#43	RP-090369	138r1		Clarification on OCNG	8.5.0
03-2009	RP#43	RP-090369	161		CQI reference measurement channels	8.5.0
03-2009	RP#43	RP-090369	164		PUCCH 1-1 Static Test Case	8.5.0
03-2009	RP#43	RP-090369	111		Reference Measurement Channel for TDD	8.5.0
03-2009	RP#44				Editorial correction in Table 6.2.4-1	8.5.1
05-2009	RP#44	RP-090540	167		Boundary between E-UTRA fOoB and spurious emission domain for 1.4 MHz and 3 MHz bandwidths. (Technically Endorsed CR in R4-50bis - R4-091205)	8.6.0
05-2009	RP#44	RP-090540	168		EARFCN correction for TDD DL bands. (Technically Endorsed CR in R4-50bis - R4-091206)	8.6.0
05-2009	RP#44	RP-090540	169		Editorial correction to in-band blocking table. (Technically Endorsed CR in R4-50bis - R4-091238)	8.6.0
05-2009	RP#44	RP-090540	171		CR PRACH EVM. (Technically Endorsed CR in R4-50bis - R4-091308)	8.6.0
05-2009	RP#44	RP-090540	172		CR EVM correction. (Technically Endorsed CR in R4-50bis - R4-091309)	8.6.0

05-2009	RP#44	RP-090540	177		CR power control accuracy. (Technically Endorsed CR in R4-50bis - R4-091418)	8.6.0
05-2009	RP#44	RP-090540	179		Correction of SRS requirements. (Technically Endorsed CR in R4-50bis - R4-091426)	8.6.0
05-2009	RP#44	RP-090540	186		Clarification for EVM. (Technically Endorsed CR in R4-50bis - R4-091512)	8.6.0
05-2009	RP#44	RP-090540	187		Removal of [ ] from band 17 Refsens values and ACS offset frequencies	8.6.0
05-2009	RP#44	RP-090540	191		Completion of band17 requirements	8.6.0
05-2009	RP#44	RP-090540	192		Removal of 1.4 MHz and 3 MHz bandwidths from bands 13, 14 and 17.	8.6.0
05-2009	RP#44	RP-090540	223		CR: 64 QAM EVM	8.6.0
05-2009	RP#44	RP-090540	201		CR In-band emissions	8.6.0
05-2009	RP#44	RP-090540	203		CR EVM exclusion period	8.6.0
05-2009	RP#44	RP-090540	204		CR In-band emissions timing	8.6.0
05-2009	RP#44	RP-090540	206		CR Minimum Rx exceptions	8.6.0
05-2009	RP#44	RP-090540	207		CR UL DM-RS EVM	8.6.0
05-2009	RP#44	RP-090540	218r1		A-MPR table for NS_07	8.6.0
05-2009	RP#44	RP-090540	205r1		CR In-band emissions in shortened subframes	8.6.0
05-2009	RP#44	RP-090540	200r1		CR PUCCH EVM	8.6.0
05-2009	RP#44	RP-090540	178r2		No additional emission mask indication. (Technically Endorsed CR in R4-50bis - R4-091421)	8.6.0
05-2009	RP#44	RP-090540	220r1		Spectrum emission requirements for band 13	8.6.0
05-2009	RP#44	RP-090540	197r2		CR on aggregate power tolerance	8.6.0
05-2009	RP#44	RP-090540	196r2		CR: Rx IP2 performance	8.6.0
05-2009	RP#44	RP-090541	198r1		Maximum output power relaxation	8.6.0
05-2009	RP#44	RP-090542	166		Update of performance requirement for TDD PDSCH with MBSFN configuration. (Technically Endorsed CR in R4-50bis - R4-091180)	8.6.0
05-2009	RP#44	RP-090542	175		Adding AWGN levels for some TDD DL performance requirements. (Technically Endorsed CR in R4-50bis - R4-091406)	8.6.0
05-2009	RP#44	RP-090542	182		OCNG Patterns for Single Resource Block FRC Requirements. (Technically Endorsed CR in R4-50bis - R4-091504)	8.6.0
05-2009	RP#44	RP-090542	170r1		Update of Clause 8: PHICH and PMI delay. (Technically Endorsed CR in R4-50bis - R4-091275)	8.6.0
05-2009	RP#44	RP-090543	183		Requirements for frequency-selective fading test. (Technically Endorsed CR in R4-50bis - R4-091505)	8.6.0
05-2009	RP#44	RP-090543	199		CQI requirements under AWGN conditions	8.6.0
05-2009	RP#44	RP-090543	188r1		Adaptation of UL-RMC-s for supporting more UE categories	8.6.0
05-2009	RP#44	RP-090543	193r1		Correction of the LTE UE downlink reference measurement channels	8.6.0
05-2009	RP#44	RP-090543	184r1		Requirements for frequency non-selective fading tests. (Technically Endorsed CR in R4-50bis - R4-091506)	8.6.0
05-2009	RP#44	RP-090543	185r1		Requirements for PMI reporting. (Technically Endorsed CR in R4-50bis - R4-091510)	8.6.0
05-2009	RP#44	RP-090543	221r1		Correction to DL RMC-s for Maximum input level for supporting more UE-Categories	8.6.0
05-2009	RP#44	RP-090543	216		Addition of 15 MHz and 20 MHz bandwidths into band 38	8.6.0
05-2009	RP#44	RP-090559	180		Introduction of Extended LTE800 requirements. (Technically Endorsed CR in R4-50bis - R4-091432)	9.0.0
09-2009	RP#45	RP-090826	239		A-MPR for Band 19	9.1.0
09-2009	RP#45	RP-090822	225		LTE UTRA ACLR1 centre frequency definition for 1.4 and 3 MHz BW	9.1.0
09-2009	RP#45	RP-090822	227		Harmonization of text for LTE Carrier leakage	9.1.0
09-2009	RP#45	RP-090822	229		Sensitivity requirements for Band 38 15 MHz and 20 MHz bandwidths	9.1.0
09-2009	RP#45	RP-090822	236		Operating band edge relaxation of maximum output power for Band 18 and 19	9.1.0
09-2009	RP#45	RP-090822	238		Addition of 5MHz channel bandwidth for Band 40	9.1.0
09-2009	RP#45	RP-090822	245		Removal of unnecessary requirements for 1.4 and 3 MHz bandwidths on bands 13 and 17	9.1.0
09-2009	RP#45	RP-090877	261		Correction of LTE UE ACS test parameter	9.1.0
09-2009	RP#45	RP-090877	263R1		Correction of LTE UE ACLR test parameter	9.1.0
09-2009	RP#45	RP-090877	286		Uplink power and RB allocation for receiver tests	9.1.0
09-2009	RP#45	RP-090877	320		CR Sensitivity relaxation for small BW	9.1.0
09-2009	RP#45	RP-090877	324		Correction of Band 3 spurious emission band UE co-existence	9.1.0
09-2009	RP#45	RP-090877	249R1		CR Pcmx definition (working assumption)	9.1.0
09-2009	RP#45	RP-090877	330		Spectrum flatness clarification	9.1.0

09-2009	RP#45	RP-090877	332		Transmit power: removal of TC and modification of REFSSENS note	9.1.0
09-2009	RP#45	RP-090877	282R1		Additional SRS relative power requirement and update of measurement definition	9.1.0
09-2009	RP#45	RP-090877	284R1		Power range applicable for relative tolerance	9.1.0
09-2009	RP#45	RP-090878	233		TDD UL/DL configurations for CQI reporting	9.1.0
09-2009	RP#45	RP-090878	235		Further clarification on CQI test configurations	9.1.0
09-2009	RP#45	RP-090878	243		Corrections to UL- and DL-RMC-s	9.1.0
09-2009	RP#45	RP-090878	247		Reference measurement channel for multiple PMI requirements	9.1.0
09-2009	RP#45	RP-090878	290		CQI reporting test for a scenario with frequency-selective interference	9.1.0
09-2009	RP#45	RP-090878	265R2		CQI reference measurement channels	9.1.0
09-2009	RP#45	RP-090878	321R1		CR RI Test	9.1.0
09-2009	RP#45	RP-090875	231		Correction of parameters for demodulation performance requirement	9.1.0
09-2009	RP#45	RP-090875	241R1		UE categories for performance tests and correction to RMC references	9.1.0
09-2009	RP#45	RP-090875	333		Clarification of Es definition in the demodulation requirement	9.1.0
09-2009	RP#45	RP-090875	326		Editorial corrections and updates to PHICH PBCH test cases.	9.1.0
09-2009	RP#45	RP-090875	259R3		Test case numbering in section 8 Performance tests	9.1.0
12-2009	RP-46	RP-091264	335		Test case numbering in TDD PDSCH performance test (Technically endorsed at RAN 4 52bis in R4-093523)	9.2.0
12-2009	RP-46	RP-091261	337		Adding beamforming model for user-specific reference signal (Technically endorsed at RAN 4 52bis in R4-093525)	9.2.0
12-2009	RP-46	RP-091263	339R1		Adding redundancy sequences to PMI test (Technically endorsed at RAN 4 52bis in R4-093581)	9.2.0
12-2009	RP-46	RP-091264	341		Throughput value correction at FRC for Maximum input level (Technically endorsed at RAN 4 52bis in R4-093660)	9.2.0
12-2009	RP-46	RP-091261	343		Correction to the modulated E-UTRA interferer (Technically endorsed at RAN 4 52bis in R4-093662)	9.2.0
12-2009	RP-46	RP-091264	345R1		OCNG: Patterns and present use in tests (Technically endorsed at RAN 4 52bis in R4-093664)	9.2.0
12-2009	RP-46	RP-091264	347		OCNG: Use in receiver and performance tests (Technically endorsed at RAN 4 52bis in R4-093666)	9.2.0
12-2009	RP-46	RP-091263	349		Miscellaneous corrections on CSI requirements (Technically endorsed at RAN 4 52bis in R4-093676)	9.2.0
12-2009	RP-46	RP-091261	351		Removal of RLC modes (Technically endorsed at RAN 4 52bis in R4-093677)	9.2.0
12-2009	RP-46	RP-091261	353		CR Rx diversity requirement (Technically endorsed at RAN 4 52bis in R4-093703)	9.2.0
12-2009	RP-46	RP-091261	355		A-MPR notation in NS_07 (Technically endorsed at RAN 4 52bis in R4-093706)	9.2.0
12-2009	RP-46	RP-091263	359		Single- and multi-PMI requirements (Technically endorsed at RAN 4 52bis in R4-093846)	9.2.0
12-2009	RP-46	RP-091263	363		CQI reference measurement channel (Technically endorsed at RAN 4 52bis in R4-093970)	9.2.0
12-2009	RP-46	RP-091292	364		LTE MBSFN Channel Model (Technically endorsed at RAN 4 52bis in R4-094020)	9.2.0
12-2009	RP-46	RP-091264	367		Numbering of PDSCH (User-Specific Reference Symbols) Demodulation Tests	9.2.0
12-2009	RP-46	RP-091264	369		Numbering of PDCCCH/PCFICH, PHICH, PBCH Demod Tests	9.2.0
12-2009	RP-46	RP-091261	371		Remove [ ] from Reference Measurement Channels in Annex A	9.2.0
12-2009	RP-46	RP-091264	373R1		Corrections to RMC-s for Maximum input level test for low UE categories	9.2.0
12-2009	RP-46	RP-091261	377		Correction of UE-category for R.30	9.2.0
12-2009	RP-46	RP-091286	378		Introduction of Extended LTE1500 requirements for TS36.101	9.2.0
12-2009	RP-46	RP-091262	384		CR: Removal of 1.4 MHz and 3 MHz channel bandwidths from additional spurious emissions requirements for Band 1 PHS protection	9.2.0
12-2009	RP-46	RP-091262	386R3		Clarification of measurement conditions of spurious emission requirements at the edge of spurious domain	9.2.0
12-2009	RP-46	RP-091262	390		Spurious emission table correction for TDD bands 33 and 38.	9.2.0
12-2009	RP-46	RP-091262	392R2		36.101 Symbols and abbreviations for P <sub>cm</sub>	9.2.0
12-2009	RP-46	RP-091262	394		UTRAACL1 requirement definition for 1.4 and 3 MHz BW completed	9.2.0
12-2009	RP-46	RP-091263	396		Introduction of the ACK/NACK feedback modes for TDD requirements	9.2.0

12-2009	RP-46	RP-091262	404R3		CR Power control exception R8	9.2.0
12-2009	RP-46	RP-091262	416R1		Relative power tolerance: special case for receiver tests	9.2.0
12-2009	RP-46	RP-091263	420R1		CSI reporting: test configuration for CQI fading requirements	9.2.0
12-2009	RP-46	RP-091284	421R1		Inclusion of Band 20 UE RF parameters	9.2.0
12-2009	RP-46	RP-091264	425		Editorial corrections and updates to Clause 8.2.1 FDD demodulation test cases	9.2.0
12-2009	RP-46	RP-091262	427		CR: time mask	9.2.0
12-2009	RP-46	RP-091264	430		Correction of the payload size for PDCCH/PCFICH performance requirements	9.2.0
12-2009	RP-46	RP-091263	432		Transport format and test point updates to RI reporting test cases	9.2.0
12-2009	RP-46	RP-091263	434		Transport format and test setup updates to frequency-selective interference CQI tests	9.2.0
12-2009	RP-46	RP-091263	436		CR RI reporting configuration in PUCCH 1-1 test	9.2.0
12-2009	RP-46	RP-091261	438		Addition of R.11-1 TDD references	9.2.0
12-2009	RP-46	RP-091292	439		Performance requirements for LTE MBMS	9.2.0
12-2009	RP-46	RP-091262	442R1		In Band Emissions Requirements Correction CR	9.2.0
12-2009	RP-46	RP-091262	444R1		PCMAX definition	9.2.0
03-2010	RP-47	RP-100246	453r1		Corrections of various errors in the UE RF requirements	9.3.0
03-2010	RP-47	RP-100246	462r1		UTRA ACLR measurement bandwidths for 1.4 and 3 MHz	9.3.0
03-2010	RP-47	RP-100246	493		Band 8 Coexistence Requirement Table Correction	9.3.0
03-2010	RP-47	RP-100246	489r1		Rel 9 CR for Band 14	9.3.0
03-2010	RP-47	RP-100246	485r1		CR Band 1- PHS coexistence	9.3.0
03-2010	RP-47	RP-100247	501		Fading CQI requirements for FDD mode	9.3.0
03-2010	RP-47	RP-100247	499		CR correction to RI test	9.3.0
03-2010	RP-47	RP-100249	451		Reporting mode, Reporting Interval and Editorial corrections for demodulation	9.3.0
03-2010	RP-47	RP-100249	464r1		Corrections to 1PRB PDSCH performance test in presence of MBSFN.	9.3.0
03-2010	RP-47	RP-100249	458r1		OCNG corrections	9.3.0
03-2010	RP-47	RP-100249	467		Addition of ONCG configuration in DRS performance test	9.3.0
03-2010	RP-47	RP-100249	465r1		PDSCH performance tests for low UE categories	9.3.0
03-2010	RP-47	RP-100250	460r1		Use of OCNG in CSI tests	9.3.0
03-2010	RP-47	RP-100250	491r1		Corrections to CQI test configurations	9.3.0
03-2010	RP-47	RP-100250	469r1		Corrections of some CSI test parameters	9.3.0
03-2010	RP-47	RP-100251	456r1		TBS correction for RMC UL TDD 16QAM full allocation BW 1.4 MHz	9.3.0
03-2010	RP-47	RP-100262	449		Editorial corrections on Band 19 REFSSENS	9.3.0
03-2010	RP-47	RP-100263	470r1		Band 20 UE RF requirements	9.3.0
03-2010	RP-47	RP-100264	446r1		A-MPR for Band 21	9.3.0
03-2010	RP-47	RP-100264	448		RF requirements for UE in later releases	9.3.0
03-2010	RP-47	RP-100268	445		36.101 CR: Editorial corrections on LTE MBMS reference measurement channels	9.3.0
03-2010	RP-47	RP-100268	454		The definition of the Doppler shift for LTE MBSFN Channel Model	9.3.0
03-2010	RP-47	RP-100239	478r3		Modification of the spectral flatness requirement and some editorial corrections	9.3.0
06-2010	RP-48	RP-100619	559		Corrections of tables for Additional Spectrum Emission Mask	9.4.0
06-2010	RP-48	RP-100619	538		Correction of transient time definition for EVM requirements	9.4.0
06-2010	RP-48	RP-100619	557r2		CR on UE coexistence requirement	9.4.0
06-2010	RP-48	RP-100619	547r1		Correction of antenna configuration and beam-forming model for DRS	9.4.0
06-2010	RP-48	RP-100619	536r1		CR: Corrections on MIMO demodulation performance requirements	9.4.0
06-2010	RP-48	RP-100619	528r1		Corrections on the definition of PCMAX	9.4.0
06-2010	RP-48	RP-100619	568		Relaxation of the PDSCH demodulation requirements due to control channel errors	9.4.0
06-2010	RP-48	RP-100619	566		Correction of the UE output power definition for RX tests	9.4.0
06-2010	RP-48	RP-100620	505r1		Fading CQI requirements for TDD mode	9.4.0
06-2010	RP-48	RP-100620	521		Correction to FRC for CQI index 0	9.4.0
06-2010	RP-48	RP-100620	516r1		Correction to CQI test configuration	9.4.0
06-2010	RP-48	RP-100620	532		Correction of CQI and PMI delay configuration description for TDD	9.4.0
06-2010	RP-48	RP-100620	574		Correction to FDD and TDD CSI test configurations	9.4.0
06-2010	RP-48	RP-100620	571		Minimum requirements for Rank indicator reporting	9.4.0
06-2010	RP-48	RP-100628	563		LTE MBMS performance requirements (FDD)	9.4.0
06-2010	RP-48	RP-100628	564		LTE MBMS performance requirements (TDD)	9.4.0
06-2010	RP-48	RP-100629	553r2		Performance requirements for dual-layer beamforming	9.4.0
06-2010	RP-48	RP-100630	524r2		CR: low Category CSI requirement	9.4.0
06-2010	RP-48	RP-100630	519		Correction of FRC reference and test case numbering	9.4.0
06-2010	RP-48	RP-100630	526		Correction of carrier frequency and EARFCN of Band 21 for TS36.101	9.4.0



06-2010	RP-48	RP-100630	508r1		Addition of PDSCH TDD DRS demodulation tests for Low UE categories	9.4.0
06-2010	RP-48	RP-100630	539		Specification of minimum performance requirements for low UE category	9.4.0
06-2010	RP-48	RP-100630	569		Addition of minimum performance requirements for low UE category TDD CRS single-antenna port tests	9.4.0
06-2010	RP-48	RP-100631	549r3		Introduction of sustained downlink data-rate performance requirements	9.4.0
06-2010	RP-48	RP-100683	530r1		Band 20 Rx requirements	9.4.0
09-2010	RP-49	RP-100920	614r2		Add OCNG to MBMS requirements	9.5.0
09-2010	RP-49	RP-100916	599		Correction of PDCCH content for PHICH test	9.5.0
09-2010	RP-49	RP-100920	597r1		Beamforming model for transmission on antenna port 7/8	9.5.0
09-2010	RP-49	RP-100920	600r1		Correction of full correlation in frequency-selective CQI test	9.5.0
09-2010	RP-49	RP-100920	601		Correction on single-antenna transmission fixed reference channel	9.5.0
09-2010	RP-49	RP-100914	605		Reference sensitivity requirements for the 1.4 and 3 MHz bandwidths	9.5.0
09-2010	RP-49	RP-100920	608r1		CR for DL sustained data rate test	9.5.0
09-2010	RP-49	RP-100919	611		Correction of references in section 10 (MBMS performance requirements)	9.5.0
09-2010	RP-49	RP-100914	613		Band 13 and Band 14 spurious emission corrections	9.5.0
09-2010	RP-49	RP-100919	617r1		Rx Requirements	9.5.0
09-2010	RP-49	RP-100926	576r1		Clarification on DL-BF simulation assumptions	9.5.0
09-2010	RP-49	RP-100920	582r1		Introduction of additional Rel-9 scenarios	9.5.0
09-2010	RP-49	RP-100925	575r1		Correction to band 20 ue to ue Co-existence table	9.5.0
09-2010	RP-49	RP-100916	581r1		Test configuration corrections to CQI reporting in AWGN	9.5.0
09-2010	RP-49	RP-100916	595		Corrections to RF OCNG Pattern OP.1 and 2	9.5.0
09-2010	RP-49	RP-100919	583		Editorial corrections of 36.101	9.5.0
09-2010	RP-49	RP-100920	586		Addition of minimum performance requirements for low UE category TDD tests	9.5.0
09-2010	RP-49	RP-100914	590r1		Downlink power for receiver tests	9.5.0
09-2010	RP-49	RP-100920	591		OCNG use and power in beamforming tests	9.5.0
09-2010	RP-49	RP-100916	593		Throughput for multi-datastreams transmissions	9.5.0
09-2010	RP-49	RP-100914	588		Missing note in Additional spurious emission test with NS_07	9.5.0
09-2010	RP-49	RP-100927	596r2		CR LTE_TDD_2600_US spectrum band definition additions to TS 36.101	10.0.0
12-2010	RP-50	RP-101309	680		Demodulation performance requirements for dual-layer beamforming	10.1.0
12-2010	RP-50	RP-101325	672		Correction on the statement of TB size and subband selection in CSI tests	10.1.0
12-2010	RP-50	RP-101327	652		Correction to Band 12 frequency range	10.1.0
12-2010	RP-50	RP-101329	630		Removal of [ ] from TDD Rank Indicator requirements	10.1.0
12-2010	RP-50	RP-101329	635r1		Test configuration corrections to CQI TDD reporting in AWGN (Rel-10)	10.1.0
12-2010	RP-50	RP-101330	645		EVM window length for PRACH	10.1.0
12-2010	RP-50	RP-101330	649		Removal of NS signalling from TDD REFSENS tests	10.1.0
12-2010	RP-50	RP-101330	642r1		Correction of Note 4 In Table 7.3.1-1: Reference sensitivity QPSK PREFSENS	10.1.0
12-2010	RP-50	RP-101341	627		Add 20 RB UL Ref Meas channel	10.1.0
12-2010	RP-50	RP-101341	654r1		Additional in-band blocking requirement for Band 12	10.1.0
12-2010	RP-50	RP-101341	678		Further clarifications for the Sustained Downlink Data Rate Test	10.1.0
12-2010	RP-50	RP-101341	673r1		Correction on MBMS performance requirements	10.1.0
12-2010	RP-50	RP-101349	667r3		CR Removing brackets of Band 41 reference sensitivity to TS 36.101	10.1.0
12-2010	RP-50	RP-101356	666r2		Band 42 and 43 parameters for UMTS/LTE 3500 (TDD) for TS 36.101	10.1.0
12-2010	RP-50	RP-101359	646r1		CR for CA, UL-MIMO, eDL-MIMO, CPE	10.1.0
12-2010	RP-50	RP-101361	620r1		Introduction of L-band in TS 36.101	10.1.0
12-2010	RP-50	RP-101379	670r1		Correction on the PMI reporting in Multi-Layer Spatial Multiplexing performance test	10.1.0
12-2010	RP-50	RP-101380	679r1		Adding antenna configuration in CQI fading test case	10.1.0
01-2011					Clause numbering correction	10.1.1
03-2011	RP-51	RP-110359	695		Removal of E-UTRA ACLR for CA	10.2.0
03-2011	RP-51	RP-110338	699		PDCCH and PHICH performance: OCNG and power settings	10.2.0
03-2011	RP-51	RP-110336	706r1		Spurious emissions measurement uncertainty	10.2.0
03-2011	RP-51	RP-110352	707r1		REFSENSE in lower SNR	10.2.0
03-2011	RP-51	RP-110338	710		PMI performance: Power settings and precoding granularity	10.2.0
03-2011	RP-51	RP-110359	715r2		Definition of configured transmitted power for Rel-10	10.2.0
03-2011	RP-51	RP-110359	717		Introduction of requirement for adjacent intraband CA image rejection	10.2.0
03-2011	RP-51	RP-110343	719		Minimum requirements for the additional Rel-9 scenarios	10.2.0

03-2011	RP-51	RP-110343	723		Corrections to power settings for Single layer beamforming with simultaneous transmission	10.2.0
03-2011	RP-51	RP-110343	726r1		Correction to the PUSCH3-0 subband tests for Rel-10	10.2.0
03-2011	RP-51	RP-110338	730		Removing the square bracket for TS36.101	10.2.0
03-2011	RP-51	RP-110349	739		Removal of square brackets for dual-layer beamforming demodulation performance requirements	10.2.0
03-2011	RP-51	RP-110359	751		CR: Maximum input level for intra band CA	10.2.0
03-2011	RP-51	RP-110349	754r2		UE category coverage for dual-layer beamforming	10.2.0
03-2011	RP-51	RP-110343	756r1		Further clarifications for the Sustained Downlink Data Rate Test	10.2.0
03-2011	RP-51	RP-110343	759		Removal of square brackets in sustained data rate tests	10.2.0
03-2011	RP-51	RP-110337	762r1		Clarification to LTE relative power tolerance table	10.2.0
03-2011	RP-51	RP-110343	764		Introducing UE-selected subband CQI tests	10.2.0
03-2011	RP-51	RP-110343	765		Verification framework for PUSCH 2-2 and PUCCH 2-1 reporting	10.2.0
04-2011					Editorial: Spec Title correction, removal of "Draft"	10.2.1
06-2011	RP-52	RP-110804	766		Add Expanded 1900MHz Band (Band 25) in 36.101	10.3.0
06-2011	RP-52	RP-110795	768		Fixing Band 24 inclusion in TS 36.101	10.3.0
06-2011	RP-52	RP-110788	772		CR: Corrections for UE to UE co-existence requirements of Band 3	10.3.0
06-2011	RP-52	RP-110812	774		Add 2GHz S-Band (Band 23) in 36.101	10.3.0
06-2011	RP-52	RP-110789	782		CR: Band 19 A-MPR refinement	10.3.0
06-2011	RP-52	RP-110796	787		REFSENS in lower SNR	10.3.0
06-2011	RP-52	RP-110789	805		Clarification for MBMS reference signal levels	10.3.0
06-2011	RP-52	RP-110792	810		FDD MBMS performance requirements for 64QAM mode	10.3.0
06-2011	RP-52	RP-110787	814		Correction on CQI mapping index of RI test	10.3.0
06-2011	RP-52	RP-110789	824		Corrections to in-band blocking table	10.3.0
06-2011	RP-52	RP-110794	826		Correction of TDD Category 1 DRS and DMRS RMCs	10.3.0
06-2011	RP-52	RP-110794	828		TDD MBMS performance requirements for 64QAM mode	10.3.0
06-2011	RP-52	RP-110796	829		Correction of TDD RMC for Low SNR Demodulation test	10.3.0
06-2011	RP-52	RP-110796	830		Informative reference sensitivity requirements for Low SNR for TDD	10.3.0
06-2011	RP-52	RP-110787	778r1		Minor corrections to DL-RMC-s for Maximum input level	10.3.0
06-2011	RP-52	RP-110789	832		PDCCH and PHICH performance: OCNG and power settings	10.3.0
06-2011	RP-52	RP-110789	818r1		Correction on 2-X PMI test for R10	10.3.0
06-2011	RP-52	RP-110791	816r1		Addition of performance requirements for dual-layer beamforming category 1 UE test	10.3.0
06-2011	RP-52	RP-110789	834		Performance requirements for PUCCH 2-0, PUCCH 2-1 and PUSCH 2-2 tests	10.3.0
06-2011	RP-52	RP-110807	835r1		CR for UL MIMO and CA	10.3.0
09-2011	RP-53	RP-111248	862r1		Removal of unnecessary channel bandwidths from REFSENS tables	10.4.0
09-2011	RP-53	RP-111248	869r1		Clarification on BS precoding information field for RI FDD and PUCCH 2-1 PMI tests	10.4.0
09-2011	RP-53	RP-111248	872r1		CR for B14Rx requirement Rrel 10	10.4.0
09-2011	RP-53	RP-111248	890r1		CR to TS36.101: Correction on the accuracy test of CQI.	10.4.0
09-2011	RP-53	RP-111248	893		CR to TS36.101: Correction on CQI mapping index of TDD RI test	10.4.0
09-2011	RP-53	RP-111248	904		Correction of code block numbers for some RMCs	10.4.0
09-2011	RP-53	RP-111248	907		Correction to UL RMC for FDD and TDD	10.4.0
09-2011	RP-53	RP-111248	914r1		Adding codebook subset restriction for single layer closed-loop spatial multiplexing test	10.4.0
09-2011	RP-53	RP-111251	883		Sustained data rate: Correction of the ACK/NACK feedback mode	10.4.0
09-2011	RP-53	RP-111251	929		36.101 CR on MBSFN FDD requirements(R10)	10.4.0
09-2011	RP-53	RP-111251	938		TDD MBMS performance requirements for 64QAM mode	10.4.0
09-2011	RP-53	RP-111252	895		Further clarification for the dual-layer beamforming demodulation requirements	10.4.0
09-2011	RP-53	RP-111255	908r1		Introduction of Band 22	10.4.0
09-2011	RP-53	RP-111255	939		Modifications of Band 42 and 43	10.4.0
09-2011	RP-53	RP-111260	944		CR for TS 36.101 Annex B: Static channels for CQI tests	10.4.0
09-2011	RP-53	RP-111262	878r1		Correction of CSI reference channel subframe description	10.4.0
09-2011	RP-53	RP-111262	887		Correction to UL MIMO	10.4.0
09-2011	RP-53	RP-111262	926r1		Power control accuracy for intra-band carrier aggregation	10.4.0
09-2011	RP-53	RP-111262	927r1		In-band emissions requirements for intra-band carrier aggregation	10.4.0
09-2011	RP-53	RP-111262	930r1		Adding the operating band for UL-MIMO	10.4.0
09-2011	RP-53	RP-111265	848		Corrections to intra-band contiguous CA RX requirements	10.4.0
09-2011	RP-53	RP-111265	863		Intra-band contiguous CA MPR requirement refinement	10.4.0
09-2011	RP-53	RP-111265	866r1		Intra-band contiguous CA EVM	10.4.0
09-2011	RP-53	RP-111266	935		Introduction of the downlink CA demodulation requirements	10.4.0
09-2011	RP-53	RP-111266	936r1		Introduction of CA UE demodulation requirements for TDD	10.4.0

12-2011	RP-54	RP-111684	947		Corrections of UE categories of Rel-10 reference channels for RF requirements	10.5.0
12-2011	RP-54	RP-111684	948		Alternative way to define channel bandwidths per operating band for	10.5.0
12-2011	RP-54	RP-111686	949		CR for TS36.101: Adding note to the function of MPR	10.5.0
12-2011	RP-54	RP-111680	950		Clarification on applying CSI reports during rank switching in RI FDD test - Rel-10	10.5.0
12-2011	RP-54	RP-111734	953r1		Corrections for Band 42 and 43 introduction	10.5.0
12-2011	RP-54	RP-111680	956		UE spurious emissions	10.5.0
12-2011	RP-54	RP-111682	959		Add scrambling identity n_SCID for MU-MIMO test	10.5.0
12-2011	RP-54	RP-111690	960r1		P-MPR definition	10.5.0
12-2011	RP-54	RP-111693	962		P <sub>max,c</sub> Computation Assumptions	10.5.0
12-2011	RP-54	RP-111733	963r1		Correction of frequency range for spurious emission requirements	10.5.0
12-2011	RP-54	RP-111680	966		General review of the reference measurement channels	10.5.0
12-2011	RP-54	RP-111691	945		Corrections of Rel-10 demodulation performance requirements This CR is only partially implemented due to confliction with CR 966	10.5.0
12-2011	RP-54	RP-111684	946		Corrections of UE categories for Rel-10 CSI requirements This CR is only partially implemented due to confliction with CR 966	10.5.0
12-2011	RP-54	RP-111691	982r2		Introduction of SDR TDD test scenario for CA UE demodulation This CR is only partially implemented due to confliction with CR 966	10.5.0
12-2011	RP-54	RP-111693	971r1		CR on Colliding CRS for non-MBSFN ABS	10.5.0
12-2011	RP-54	RP-111693	972r1		Introduction of eICIC demodulation performance requirements for FDD and TDD	10.5.0
12-2011	RP-54	RP-111686	985		Adding missing UL configuration specification in some UE receiver requirements for case of 1 CC UL capable UE	10.5.0
12-2011	RP-54	RP-111684	998		Correction and maintenance on CQI and PMI requirements (Rel-10)	10.5.0
12-2011	RP-54	RP-111735	1004		MPR for CA Multi-cluster	10.5.0
12-2011	RP-54	RP-111691	1005		CA demodulation performance requirements for LTE FDD	10.5.0
12-2011	RP-54	RP-111692	1006		CQI reporting accuracy test on frequency non-selective scheduling on eDL MIMO	10.5.0
12-2011	RP-54	RP-111692	1007		CQI reporting accuracy test on frequency-selective scheduling on eDL MIMO	10.5.0
12-2011	RP-54	RP-111692	1008		PMI reporting accuracy test for TDD on eDL MIMO	10.5.0
12-2011	RP-54	RP-111692	1009r1		CR for TS 36.101: RI performance requirements	10.5.0
12-2011	RP-54	RP-111692	1010r1		CR for TS 36.101: Introduction of static CQI tests (Rel-10)	10.5.0
03-2012	RP-55	RP-120291	1014		RF: Updates and corrections to the RMC-s related annexes (Rel-10)	10.6.0
03-2012	RP-55	RP-120300	1015r1		On eICIC ABS pattern	10.6.0
03-2012	RP-55	RP-120300	1016r1		On eICIC interference models	10.6.0
03-2012	RP-55	RP-120299	1017r1		TS36.101 CR: on eDL-MIMO channel model using cross-polarized antennas	10.6.0
03-2012	RP-55	RP-120304	1020r1		TS36.101 CR: Correction to MBMS Performance Test Parameters	10.6.0
03-2012	RP-55	RP-120303	1021		Harmonic exceptions in LTE UE to UE co-ex tests	10.6.0
03-2012	RP-55	RP-120304	1023		Unified titles for Rel-10 CSI tests	10.6.0
03-2012	RP-55	RP-120300	1033r1		Introduction of reference channel for eICIC demodulation	10.6.0
03-2012	RP-55	RP-120304	1040r1		Correction of Actual code rate for CSI RMCs	10.6.0
03-2012	RP-55	RP-120304	1041r1		Definition of synchronized operation	10.6.0
03-2012	RP-55	RP-120296	1048r1		Intra band contiguous CA Ue to Ue Co-ex	10.6.0
03-2012	RP-55	RP-120296	1049r1		REL-10 CA specification editorial consistency	10.6.0
03-2012	RP-55	RP-120299	1053		Beamforming model for TM9	10.6.0
03-2012	RP-55	RP-120296	1054		Requirement for CA demodulation with power imbalance	10.6.0
03-2012	RP-55	RP-120298	1057		Updating Band 23 duplex specifications	10.6.0
03-2012	RP-55	RP-120298	1058r1		Correcting UE Coexistence Requirements for Band 23	10.6.0
03-2012	RP-55	RP-120304	1059r1		CA demodulation performance requirements for LTE TDD	10.6.0
03-2012	RP-55	RP-120304	1061		Requirement for CA SDR FDD test scenario	10.6.0

03-2012	RP-55	RP-120293	1064r1		TS36.101 RF editorial corrections Rel 10	10.6.0
03-2012	RP-55	RP-120299	1067r1		Introduction of TM9 demodulation performance requirements	10.6.0
03-2012	RP-55	RP-120304	1071r1		Introduction of a CA demodulation test for UE soft buffer management testing	10.6.0
03-2012	RP-55	RP-120296	1072		MPR formula correction For intra-band contiguous CA Bandwidth Class C	10.6.0
03-2012	RP-55	RP-120303	1077r1		CR for 36.101: B41 REFSSENS and MOP changes to accommodate single filter architecture	10.6.0
03-2012	RP-55	RP-120300	1082		TM3 tests for eICIC	10.6.0
03-2012	RP-55	RP-120300	1083r1		Introduction of requirements of CQI reporting definition for eICIC	10.6.0
03-2012	RP-55	RP-120304	1084		eDL MIMO CSI requirements	10.6.0
03-2012	RP-55	RP-120306	1070r1		Introduction of Band 26/XXVI to TS 36.101	11.0.0
03-2012	RP-55	RP-120310	1074		Band 41 CA CR for TS36.101, section 5	11.0.0
03-2012	RP-55	RP-120310	1075r1		Band 41 CA CR for TS36.101, section 6	11.0.0
03-2012	RP-55	RP-120310	1076		Band 41 CA CR for TS36.101, section 7	11.0.0
06-2012	RP-56	RP-120795	1085r2		Modulator specification tightening	11.1.0
06-2012	RP-56	RP-120777	1087r1		Carrier aggregation Relative power tolerance, removal of TBD.	11.1.0
06-2012	RP-56	RP-120783	1089		UE spurious emissions for Band 7 and Band 38 coexistence	11.1.0
06-2012	RP-56	RP-120780	1092		Deleting square brackets in Reference Measurement Channels	11.1.0
06-2012	RP-56	RP-120779	1097		CR to TS36.101: Correction on parameters for the eDL-MIMO CQI and PMI tests	11.1.0
06-2012	RP-56	RP-120780	1098r1		CR to TS36.101: Fixed reference channel for PDSCH demodulation performance requirements on eDL-MIMO – NOT implemented as it is based on a wrong version of the spec	11.1.0
06-2012	RP-56	RP-120774	1107		RMC correction on eDL-MIMO RI test	11.1.0
06-2012	RP-56	RP-120774	1108r1		FRC correction on frequency selective CQI and PMI test (Rel-11)	11.1.0
06-2012	RP-56	RP-120774	1111		Correction on test point for PMI test (Rel-11)	11.1.0
06-2012	RP-56	RP-120784	1114r1		Corrections and clarifications on eICIC demodulation test	11.1.0
06-2012	RP-56	RP-120784	1117r1		Corrections and clarifications on eICIC CSI tests	11.1.0
06-2012	RP-56	RP-120783	1119r1		Corrections on UE performance requirements	11.1.0
06-2012	RP-56	RP-120773	1120		Introduction of CA band combination Band1 + Band19 to TS 36.101	11.1.0
06-2012	RP-56	RP-120769	1127		Addition of ETU30 channel model	11.1.0
06-2012	RP-56	RP-120773	1140		Addition of Maximum Throughput for R.30-1 TDD RMC	11.1.0
06-2012	RP-56	RP-120779	1141		CR for 36.101: The clarification of MPR and A-MPR for CA	11.1.0
06-2012	RP-56	RP-120784	1142		Corrections for eICIC demod test case with MBSN ABS	11.1.0
06-2012	RP-56	RP-120785	1144		Removing brackets of contiguous allocation A-MPR for CA_NS_04	11.1.0
06-2012	RP-56	RP-120784	1149r1		Introduction of PDCCH test with colliding RS on MBSFN-ABS	11.1.0
06-2012	RP-56	RP-120784	1153r1		Some clarifications and OCNG pattern for eICIC demodulation requirements	11.1.0
06-2012	RP-56	RP-120773	1155		Introduction of TDD CA Soft Buffer Limitation	11.1.0
06-2012	RP-56	RP-120795	1156		B26 and other editorial corrections	11.1.0
06-2012	RP-56	RP-120779	1161		Corrections on CQI and PMI test	11.1.0
06-2012	RP-56	RP-120780	1163		FRC for TDD PMI test	11.1.0
06-2012	RP-56	RP-120778	1165r1		Clean-up of UL-MIMO for TS36.101	11.1.0
06-2012	RP-56	RP-120782	1171		Removal of unnecessary references to single carrier requirements from Interband CA subclauses	11.1.0
06-2012	RP-56	RP-120781	1174		PDCCH wrong detection in receiver spurious emissions test	11.1.0
06-2012	RP-56	RP-120776	1184		Corrections to 3500 MHz	11.1.0
06-2012	RP-56	RP-120793	1189r2		Introduction of Band 44	11.1.0
06-2012	RP-56	RP-120784	1193r1		Target SNR setting for eICIC demodulation requirement	11.1.0
06-2012	RP-56	RP-120780	1196		Editorial simplification to CA REFSSENS UL allocation table	11.1.0
06-2012	RP-56	RP-120778	1199		Correction of wrong table references in CA receiver tests	11.1.0
06-2012	RP-56	RP-120791	1200r1		Introduction of e850_LB (Band 27) to TS 36.101	11.1.0
06-2012	RP-56	RP-120764	1212		Correction of PHS protection requirements for TS 36.101	11.1.0

06-2012	RP-56	RP-120793	1213r1		Introduction of Band 28 into TS36.101	11.1.0
06-2012	RP-56	RP-120781	1215r1		Proposed revision of subclause 4.3A for TS36.101	11.1.0
06-2012	RP-56	RP-120781	1217r1		Proposed revision on subclause 6.3.4A for TS36.101	11.1.0
06-2012	RP-56	RP-120795	1219r1		Aligning requirements between Band 18 and Band 26 in TS36.101	11.1.0
06-2012	RP-56	RP-120782	1221		SNR definition	11.1.0
06-2012	RP-56	RP-120778	1223		Correction of CSI configuraion for CA TM4 tests R11	11.1.0
06-2012	RP-56	RP-120773	1225		CR on CA UE receiver timing window R11	11.1.0
06-2012	RP-56	RP-120784	1226		Extension of static eICIC CQI test	11.1.0
09-2012	RP-57	RP-121294	1230		Correct Transport Block size in 9RB 16QAM Uplink Reference Measurement Channel	11.2.0
09-2012	RP-57	RP-121313	1233r1		RF: Corrections to power allocation parameters for transmission mode 8 (Rel-11)	11.2.0
09-2012	RP-57	RP-121304	1235		RF-CA: non-CA notation and applicability of test points in scenarios without and with CA operation (Rel-11)	11.2.0
09-2012	RP-57	RP-121305	1237		ACK/NACK feedback modes for FDD and TDD TM4 CA demodulation requirements (Rel-11)	11.2.0
09-2012	RP-57	RP-121305	1239		Correction of feedback mode for CA TDD demodulation requirements (resubmission of R4-63AH-0194 for Rel-11)	11.2.0
09-2012	RP-57	RP-121302	1241		ABS pattern setup for MBSFN ABS test (resubmission of R4-63AH-0204 for Rel-11)	11.2.0
09-2012	RP-57	RP-121302	1243		CR on eICIC CQI definition test (resubmission of R4-63AH-0205 for Rel-11)	11.2.0
09-2012	RP-57	RP-121302	1245		Transmission of CQI feedback and other corrections (Rel-11)	11.2.0
09-2012	RP-57	RP-121302	1247		Target SNR setting for eICIC MBSFN-ABS demodulation requirements (Rel-11)	11.2.0
09-2012	RP-57	RP-121335	1248		Introduction of CA_1_21 RF requirements into TS36.101	11.2.0
09-2012	RP-57	RP-121300	1251		Corrections of spurious emission band UE co-existence applicable in Japan	11.2.0
09-2012	RP-57	RP-121306	1253		Correction on RMC for frequency non-selective CQI test	11.2.0
09-2012	RP-57	RP-121306	1255		Requirements for the eDL-MIMO CQI test	11.2.0
09-2012	RP-57	RP-121302	1257		Clarification on PDSCCH test setup under MBSFN ABS	11.2.0
09-2012	RP-57	RP-121316	1258		Update of Band 28 requirements	11.2.0
09-2012	RP-57	RP-121313	1262		Applicability of statement allowing RBW < Meas BW for spurious	11.2.0
09-2012	RP-57	RP-121298	1265		Clarification of RB allocation for DRS demodulation tests	11.2.0
09-2012	RP-57	RP-121304	1267		Removal of brackets for CA Tx	11.2.0
09-2012	RP-57	RP-121337	1268r1		TS 36.101 CR for CA_38	11.2.0
09-2012	RP-57	RP-121327	1269		Introduction of CA_B7_B20 in 36.101	11.2.0
09-2012	RP-57	RP-121313	1271		Corrections of FRC subframe allocations and other minor problems	11.2.0
09-2012	RP-57	RP-121305	1274		Introduction of requirements for TDD CA Soft Buffer Limitation	11.2.0
09-2012	RP-57	RP-121307	1276		Correction of eDL-MIMO CSI RMC tables and references	11.2.0
09-2012	RP-57	RP-121307	1278		Correction of MIMO channel model for polarized antennas	11.2.0
09-2012	RP-57	RP-121303	1280		Addition of 15 and 20MHz Bandwidths for Band 23 to TS 36.101 (Rel-11)	11.2.0
09-2012	RP-57	RP-121334	1283r1		Add requirements for inter-band CA of B_1-18 and B_11-18 in TS36.101	11.2.0
09-2012	RP-57	RP-121304	1285r1		CR for MPR mask for multi-clustered simultaneous transmission in single CC in Rel-11	11.2.0
09-2012	RP-57	RP-121447	1288r2		Introduction of Japanese Regulatory Requirements to LTE Band 8(R11)	11.2.0
09-2012	RP-57	RP-121315	1289		CR for Band 27 MOP	11.2.0
09-2012	RP-57	RP-121315	1290		CR for Band 27 A-MPR	11.2.0
09-2012	RP-57	RP-121316	1291		CR to replace protected frequency range with new band number 27	11.2.0
09-2012	RP-57	RP-121215	1292r1		Introduction of CA band combination Band3 + Band5 to TS 36.101	11.2.0
09-2012	RP-57	RP-121306	1300r1		Requirements for eDL-MIMO RI test	11.2.0
09-2012	RP-57	RP-121306	1304		Corrections to TM9 demodulation tests	11.2.0
09-2012	RP-57	RP-121313	1306		Correction to PCFICH power parameter setting	11.2.0
09-2012	RP-57	RP-121306	1310r1		Correction on frequency non-selective CQI test	11.2.0
09-2012	RP-57	RP-121306	1313r1		eDL-MIMO CQI/PMI test	11.2.0
09-2012	RP-57	RP-121313	1316		Correction of the definition of unsynchronized operation	11.2.0
09-2012	RP-57	RP-121304	1320r1		Correction to Transmit Modulation Quality Tests for Intra-Band CA	11.2.0

09-2012	RP-57	RP-121338	1324r 2		36.101 CR for LTE_CA_B7	11.2.0
09-2012	RP-57	RP-121331	1325		Introduction of CA_3_20 RF requirements into TS36.101	11.2.0
09-2012	RP-57	RP-121316	1326		A-MPR table correction for NS_18	11.2.0
09-2012	RP-57	RP-121304	1332r 1		Bandwidth combination sets for intra-band and inter-band carrier aggregation	11.2.0
09-2012	RP-57	RP-121325	1339		Introduction of LTE Advanced Carrier Aggregation of Band 4 and Band 13	11.2.0
09-2012	RP-57	RP-121326	1340r 1		Introduction of CA configurations CA-12A-4A and CA-17A-4A	11.2.0
09-2012	RP-57	RP-121324	1341		Introduction of CA_B3_B7 in 36.101	11.2.0
09-2012	RP-57	RP-121328	1343		Introduction of Band 2 + Band 17 inter-band CA configuration into 36.101	11.2.0
09-2012	RP-57	RP-121306	1351		FRC for TM9 FDD	11.2.0
09-2012	RP-57	RP-121295	1352		Random precoding granularity in PMI tests	11.2.0
09-2012	RP-57	RP-121302	1358		Introduction of RI test for eCIC	11.2.0
09-2012	RP-57	RP-121304	1360		Notes for deltaTib and deltaRib tables	11.2.0
09-2012	RP-57	RP-121304	1361		CR for A-MPR masks for NS_CA_1C	11.2.0
12-2012	RP-58	RP-121884	1362		Introduction of CA_3_8 RF requirements to TS 36.101	11.3.0
12-2012	RP-58	RP-121870	1363		Removal of square brackets for Band 27 in Table 5.6.1-1	11.3.0
12-2012	RP-58	RP-121861	1366		Some changes related to CA tests and overview table of DL measurement channels	11.3.0
12-2012	RP-58	RP-121860	1368		Correction of eCIC CQI tests	11.3.0
12-2012	RP-58	RP-121860	1370		Correction of eCIC demodulation tests	11.3.0
12-2012	RP-58	RP-121862	1374		Correction on CSI-RS subframe offset parameter	11.3.0
12-2012	RP-58	RP-121862	1376		Correction on FRC table in CSI test	11.3.0
12-2012	RP-58	RP-121862	1382		Correction of reference channel table for TDD eDL-MIMO RI test	11.3.0
12-2012	RP-58	RP-121850	1386		OCNG patterns for Sustained Data rate testing	11.3.0
12-2012	RP-58	RP-121867	1388r 1		Introduction of one periodic CQI test for CA deployments	11.3.0
12-2012	RP-58	RP-121894	1396		Introduction of CA_B5_B12 in 36.101	11.3.0
12-2012	RP-58	RP-121850	1401		Introducing the additional frequency bands of 5 MHz x 2 in 1.7 GHz in Japan to Band 3	11.3.0
12-2012	RP-58	RP-121887	1406r 1		Reference sensitivity for the small bandwidth of CA_4-12	11.3.0
12-2012	RP-58	RP-121860	1407		CR on eCIC RI test	11.3.0
12-2012	RP-58	RP-121862	1409		Cleaning of 36.101 Performance sections Rel-11	11.3.0
12-2012	RP-58	RP-121861	1416		Out-of-band blocking requirements for inter-band carrier aggregation	11.3.0
12-2012	RP-58	RP-121861	1418		Adding missed SNR reference values for CA soft buffer tests	11.3.0
12-2012	RP-58	RP-121890	1422		Introduction of CA_4A-5A into 36.101	11.3.0
12-2012	RP-58	RP-121867	1431		Clean up of specification R11	11.3.0
12-2012	RP-58	RP-121867	1436		Band 1 to Band 33 and Band 39 UE coexistence requirements	11.3.0
12-2012	RP-58	RP-121871	1437r 1		Editorial corrections for Band 26	11.3.0
12-2012	RP-58	RP-121896	1438		Introduction of Band 5 + Band 17 inter-band CA configuration into 36.101	11.3.0
12-2012	RP-58	RP-121862	1442		Correction of eDL-MIMO RI test and RMC table for the CSI test	11.3.0
12-2012	RP-58	RP-121861	1444		Minor correction to ceiling function example - rel11	11.3.0
12-2012	RP-58	RP-121862	1449		Correction of SNR definition	11.3.0
12-2012	RP-58	RP-121860	1450		Brackets clean up for eCIC CSI/demodulation	11.3.0
12-2012	RP-58	RP-121860	1455		CR on eCIC RI testing (Rel-11)	11.3.0
12-2012	RP-58	RP-121862	1459		Correction on FRC table	11.3.0
12-2012	RP-58	RP-121879	1461r 1		CR for LTE_B14 HPUE (Power Class 1)	11.3.0
12-2012	RP-58	RP-121862	1464		Adding references to the appropriate beamforming model (Rel-11)	11.3.0
12-2012	RP-58	RP-121898	1465r 1		Introduction of CA_8_20 RF requirements into TS36.101	11.3.0
12-2012	RP-58	RP-121882	1468r 1		Introduction of inter-band CA_11-18 into TS36.101	11.3.0
12-2012	RP-58	RP-121903	1472r 1		Introduction of advanced receivers demodulation performance (FDD)	11.3.0
12-2012	RP-58	RP-121903	1473r 1		Introduction of performance requirements for verifying the receiver type for advanced receivers (FDD/TDD)	11.3.0
12-2012	RP-58	RP-121886	1474		CR to remove the square bracket of A-MPR in TS36.101	11.3.0
12-2012	RP-58	RP-121861	1476		Correction of some errors in reference sensitivity for CA in TS 36.101 (R11)	11.3.0
12-2012	RP-58	RP-121903	1480r 1		Introduction of Advanced Receivers Test Cases for TDD	11.3.0

12-2012	RP-58	RP-121901	1490r1		Introduction of Band 29	11.3.0
12-2012	RP-58	RP-121849	1494		Low-channel Band 1 coexistence with PHS	11.3.0
12-2012	RP-58	RP-121861	1498r1		Completion of the tables of bandwidth combinations specified for CA	11.3.0
12-2012	RP-58	RP-121861	1499r1		Exceptions to REFSSENS requirements for class A2 CA combinations	11.3.0
12-2012	RP-58	RP-121892	1500		Introduction of carrier aggregation configuration CA_4-7	11.3.0
12-2012	RP-58	RP-121870	1504		Editorial corrections to Band 27 specifications	11.3.0
12-2012	RP-58	RP-121878	1505		Band 28 AMPR for DTV protection	11.3.0
12-2012	RP-58	RP-121852	1509r1		UE-UE coexistence between bands with small frequency separation	11.3.0
12-2012	RP-58	RP-121911	1510		Adding UE-UE Coexistence Requirement for Band 3 and Band 26	11.3.0
12-2012	RP-58	RP-121866	1513		Maintenance of Band 23 UE Coexistence	11.3.0
12-2012	RP-58	RP-121851	1515		Corrections to TM4 rank indicator Test 3	11.3.0
12-2012	RP-58	RP-121861	1517		Correction of test configurations and FRC for CA demodulation with power imbalance	11.3.0
12-2012	RP-58	RP-121860	1518		Applicable OFDM symbols of Noc_2 for PDCCH/PCFICH ABS-MBSFN test cases	11.3.0
03-2013	RP-59	RP-130279	1519		OCNG patterns for Enhanced Performance Requirements Type A	11.4.0
03-2013	RP-59	RP-130277	1520		Corrections on in-band blocking for Band 29 for carrier aggregation	11.4.0
03-2013	RP-59	RP-130268	1523		Brackets removal in Rel-11 TM4 rank indicator Test 3	11.4.0
03-2013	RP-59	RP-130279	1524r1		Cleanup of Advanced Receivers requirement scenarios for demodulation and CSI (FDD/TDD)	11.4.0
03-2013	RP-59	RP-130258	1528		Corrections to CQI reporting	11.4.0
03-2013	RP-59	RP-130262	1536		Corrections for eICIC performance requirements (rel-11)	11.4.0
03-2013	RP-59	RP-130264	1539		Correction of CA power imbalance performance requirements	11.4.0
03-2013	RP-59	RP-130287	1543		Correction of a symbol for MPR in single carrier for TS 36.101(R11)	11.4.0
03-2013	RP-59	RP-130287	1544r1		Correction of some inter-band CA requirements for TS 36.101 (R11)	11.4.0
03-2013	RP-59	RP-130276	1546		Correction of contiguous allocation A-MPR for CA_NS_05	11.4.0
03-2013	RP-59	RP-130263	1547r1		Clarification of spurious emission domain for CA in TS 36.101 (R11)	11.4.0
03-2013	RP-59	RP-130264	1548		CR for CA performance requirements	11.4.0
03-2013	RP-59	RP-130284	1553r1		Introduction of downlink non-contiguous CA into REL -11 TS 36.101	11.4.0
03-2013	RP-59	RP-130263	1557		CA_1C; CA_NS_02 and CA_NS_03 A-MPR REL-11	11.4.0
03-2013	RP-59	RP-130287	1560		Editorial corrections to subclause 5	11.4.0
03-2013	RP-59	RP-130267	1562		Addition of UE Regional Requirements to Band 23 Based on New Regulatory Order in the US	11.4.0
03-2013	RP-59	RP-130272	1567		Band 26: modification of A-MPR for 'NS_15'	11.4.0
03-2013	RP-59	RP-130287	1571r1		Band 41 requirements for operation in China and Japan	11.4.0
03-2013	RP-59	RP-130260	1574		Remove [ ] from CSI test case parameters	11.4.0
03-2013	RP-59	RP-130287	1575		Corrections to UE co-existence	11.4.0
03-2013	RP-59	RP-130287	1579		UE-UE co-existence between Band 1 and Band 33/39	11.4.0
03-2013	RP-59	RP-130287	1580		Correction on reference to note for Band 7 and 38 co-existence	11.4.0
03-2013	RP-59	RP-130263	1584r1		Cleanup for CA UE RF requirements	11.4.0
03-2013	RP-59	RP-130263	1586		Corrections on UL configuration for CA UE receiver requirements	11.4.0
03-2013	RP-59	RP-130263	1588		Correction of Transmit modulation quality requirements for CA	11.4.0
03-2013	RP-59	RP-130268	1590		Revision of Common Test Parameters for User-specific Demodulation Tests	11.4.0
03-2013	RP-59	RP-130278	1595		Correction for a Band 27 A-MPR table	11.4.0
03-2013	RP-59	RP-130264	1597		Correction of CA CQI test setup	11.4.0
03-2013	RP-59	RP-130287	1600r1		Correction of B12 DL Specification in Table 5.5A-2	11.4.0
03-2013	RP-59	RP-130263	1602		Correction of table reference	11.4.0
06-2013	RP-60	RP-130765	1604r1		Complementary description for definition of MIMO Correlation Matrices using cross polarized antennas	11.5.0
06-2013	RP-60	RP-130763	1607		Correction of transport format parameters for CQI index 10 (15 RBs) - Rel 11	11.5.0
06-2013	RP-60	RP-130765	1610		Maintenance of Band 23 A-MPR (NS_11) in TS 36.101 (Rel-11)	11.5.0
06-2013	RP-60	RP-130770	1613		CR for 36.101 : Adding the definition of CA_NS_05 and CA_NS_06 for additional spurious emissions for CA	11.5.0

06-2013	RP-60	RP-130770	1619		CR for introducing UE TM3 demodulation performance requirements under high speed	11.5.0
06-2013	RP-60	RP-130765	1623		Correction of test parameters for eICIC performance requirements	11.5.0
06-2013	RP-60	RP-130765	1625		Correction of test parameters for eICIC CSI requirements	11.5.0
06-2013	RP-60	RP-130765	1627		Correction of resource allocation for the multiple PMI Cat 1 UE test	11.5.0
06-2013	RP-60	RP-130766	1629		Removal of note 2 from band 28	11.5.0
06-2013	RP-60	RP-130770	1641		Correction of the CSI-RS parameter configuration	11.5.0
06-2013	RP-60	RP-130770	1650r1		Addition of Band 41 for intra-band non-contiguous CA for 36.101	11.5.0
06-2013	RP-60	RP-130770	1654r1		MPR for intra-band non-contiguous CA	11.5.0
06-2013	RP-60	RP-130765	1656		Modification of configured output power to account for larger tolerance	11.5.0
06-2013	RP-60	RP-130769	1658r1		Missing symbols in the NS_15 table	11.5.0
06-2013	RP-60	RP-130766	1673		Corrections to Rx requirements for inter-band CA configurations with REFSENS exceptions	11.5.0
06-2013	RP-60	RP-130770	1681r1		Correction for TS 36.101	11.5.0
06-2013	RP-60	RP-130763	1684		RF: Corrections to RMC-s for sustained data rate test	11.5.0
06-2013	RP-60	RP-130770	1685		Non-contiguous intraband CA channel spacing	11.5.0
06-2013	RP-60	RP-130766	1689		Carrier aggregation in multi RAT and multiple band combination terminals	11.5.0
06-2013	RP-60	RP-130766	1691		Completion of out-of-band blocking requirements for inter-band CA with one UL	11.5.0
06-2013	RP-60	RP-130767	1695r1		CR on the bandwidth coverage issue of CA demodulation performance (Rel-11)	11.5.0
06-2013	RP-60	RP-130765	1697		Correction on UE maximum output power for intra-band CA (R11)	11.5.0
06-2013	RP-60	RP-130770	1698r1		CR for introduction of FeICIC demodulation performance requirements	11.5.0
06-2013	RP-60	RP-130770	1701		Removing bracket from CA_11A-18A requirements	11.5.0
06-2013	RP-60	RP-130767	1703		CR on the bandwidth coverage issue of CA CQI performance (Rel-11)	11.5.0
06-2013	RP-60	RP-130766	1705		Corrections to ACLR for Rel-11 CA	11.5.0
06-2013	RP-60	RP-130765	1716		Corrections to NS_11 A-MPR Table	11.5.0
06-2013	RP-60	RP-130769	1717		Corrections to NS_12 A-MPR Table	11.5.0
06-2013	RP-60	RP-130771	1532r1		Introduction of CA 1+8 into TS36.101(Rel-12)	12.0.0
06-2013	RP-60	RP-130781	1545r1		Introduction of LTE Advanced inter-band Carrier Aggregation of Band 3 and Band 28 to TS 36.101	12.0.0
06-2013	RP-60	RP-130785	1608r1		Introduction of LTE Advanced inter-band Carrier Aggregation of Band 23 and Band 29 to TS 36.101	12.0.0
06-2013	RP-60	RP-130777	1642r1		Introduction of CA B3+19 into TS36.101(Rel-12)	12.0.0
06-2013	RP-60	RP-130787	1687		Introduction of CA_4A-4A into 36.101	12.0.0
06-2013	RP-60	RP-130795	1712		Adding 5MHz CBW for B3 of Inter band CA of B3+26	12.0.0
06-2013	RP-60	RP-130775	1713r1		Introduction of LTE Advanced Inter-Band Carrier Aggregation of Band 2 and Band 13	12.0.0
06-2013	RP-60	RP-130790	1723r1		Introduction of the LTE 450 band to TS 36.101	12.0.0
06-2013	RP-60	RP-130791	1724r1		Introduction of the WCS band to TS 36.101	12.0.0
06-2013	RP-60	RP-130784	1707r1		Introduction of CA 19+21 into TS36.101(Rel-12)	12.0.0
09-2013	RP-61	RP-131300	1730r1		36.101 CR for LTE_CA_C_B3	12.1.0
09-2013	RP-61	RP-131285	1732		CR on performance requirements of CA soft buffer management (Rel-12)	12.1.0
09-2013	RP-61	RP-131303	1733r1		CR to introduce TM3 and TM4 test for 5MHz channel bandwidth	12.1.0
09-2013	RP-61	RP-131281	1736		CR on applicability of CA sustained data rate tests (Rel-12)	12.1.0
09-2013	RP-61	RP-131293	1739		Performance requirement for UE under EVA200	12.1.0
09-2013	RP-61	RP-131290	1743		CR for introduction of FeICIC PBCH performance requirement	12.1.0
09-2013	RP-61	RP-131290	1745		CR for introduction of FeICIC RI reporting requirements	12.1.0
09-2013	RP-61	RP-131292	1747		Beamforming model for EPDCCH test	12.1.0
09-2013	RP-61	RP-131303	1748		CR to introduce CSI tests for LTE450	12.1.0
09-2013	RP-61	RP-131303	1749		CR to extend UE category of the existing 5MHz performance requirements	12.1.0
09-2013	RP-61	RP-131281	1767		UE REFSENS when supporting intra-band CA and inter-band CA	12.1.0



09-2013	RP-61	RP-131279	1772		Correlation matrix for high speed train demodulation scenarios (Rel-12)	12.1.0
09-2013	RP-61	RP-131280	1776		Corrections to sustained data rate test (Rel-12)	12.1.0
09-2013	RP-61	RP-131303	1781		CR to introduce a new PHICH test based on 5MHz	12.1.0
09-2013	RP-61	RP-131303	1782		CR placeholder for applicability of new 5MHz tests	12.1.0
09-2013	RP-61	RP-131303	1783r1		CR : Proposal of applicability of new 5MHz tests	12.1.0
09-2013	RP-61	RP-131303	1784		CR: PHICH tests for 5MHz	12.1.0
09-2013	RP-61	RP-131290	1786		CR for introduction of FeICIC CQI requirements	12.1.0
09-2013	RP-61	RP-131281	1794		Clarification of multi-cluster transmission	12.1.0
09-2013	RP-61	RP-131294	1800r1		CA UE Coexistence Table update (Release 12)	12.1.0
09-2013	RP-61	RP-131302	1802		Coexistence between Band 27 and Band 38 (Release 12)	12.1.0
09-2013	RP-61	RP-131285	1803		Additional requirement for CA_1A-18A into TS36.101	12.1.0
09-2013	RP-61	RP-131296	1804		Add requirements for CA_1A-26A into TS36.101	12.1.0
09-2013	RP-61	RP-131281	1807		Incorrect REFSSENS UL allocation for CA_1C	12.1.0
09-2013	RP-61	RP-131297	1808r1		Introduction of CA_2A-4A into 36.101	12.1.0
09-2013	RP-61	RP-131281	1811		Contiguous intraband CA REFSSENS with one UL	12.1.0
09-2013	RP-61	RP-131281	1822		The Pcmx clauses restructured: This CR was NOT implemented as it was based on the wrong version of the spec	12.1.0
09-2013	RP-61	RP-131298	1824		Introduction of inter-band CA Band 2+5	12.1.0
09-2013	RP-61	RP-131285	1831		MPR for intra-band non-contiguous CA	12.1.0
09-2013	RP-61	RP-131281	1832		Correction to Rel-10 A-MPR for CA_NS_04	12.1.0
09-2013	RP-61	RP-131285	1834		CR for 36.101 : Add the definition of 5+20MHz for spectrum emission mask for CA	12.1.0
09-2013	RP-61	RP-131303	1839		CR to introduce CSI tests for LTE450	12.1.0
09-2013	RP-61	RP-131293	1840		Remianed Transmitter requirements for intra-band non-contiguous CA	12.1.0
09-2013	RP-61	RP-131303	1841		CR to introduce TM3 and TM4 test for 5MHz channel bandwidth	12.1.0
12-2013	RP-62	RP-131928	1847r1		Corrections to the notes in the band UE co-existence requirements table (Rel-12)	12.2.0
12-2013	RP-62	RP-131924	1852		Clean-up of uplink reference measurement channels (Rel-12)	12.2.0
12-2013	RP-62	RP-131946	1857		Introduction of CA band combination Band2 + Band12 to TS 36.101	12.2.0
12-2013	RP-62	RP-131954	1858		Introduction of CA band combination Band12 + Band25 to TS 36.101	12.2.0
12-2013	RP-62	RP-131931	1867		CA_NS_05 Emissions	12.2.0
12-2013	RP-62	RP-131939	1869		NS signaling for CA refsens	12.2.0
12-2013	RP-62	RP-131965	1870		Introduction of CA_23A-23A RF requirements into 36.101	12.2.0
12-2013	RP-62	RP-131928	1877r2		Intraband CA channel bandwidth combination table restructuring	12.2.0
12-2013	RP-62	RP-131940	1878		Addition of CA_3C missing UE to UE co-existence requirement and corection to SEM	12.2.0
12-2013	RP-62	RP-131959	1885		Introduction of LTE_CA_C_B27 to 36.101	12.2.0
12-2013	RP-62	RP-131939	1887		CR on correction of definition on Fraction of Maximum Throughput for CA	12.2.0
12-2013	RP-62	RP-131939	1889		CR on correction of test configurations of CA soft buffer tests	12.2.0
12-2013	RP-62	RP-131936	1893		CR for FeICIC demodulation performance requirements	12.2.0
12-2013	RP-62	RP-131936	1895r1		CR on FeICIC PBCH performance requirement	12.2.0
12-2013	RP-62	RP-131936	1897r1		CR on RI reporting requirement	12.2.0
12-2013	RP-62	RP-131938	1899		Beamforming model for EPDCCH localized test	12.2.0
12-2013	RP-62	RP-131938	1901		Downlink physical setup for EPDCCH test	12.2.0
12-2013	RP-62	RP-131926	1904		Correction on the UE category for eICIC CQI test	12.2.0
12-2013	RP-62	RP-131931	1906		CR for receiver type verification test of CSI-RS based advanced receivers (Rel-12)	12.2.0
12-2013	RP-62	RP-131956	1910r1		Spurious emission band UE co-existence requirements for cross-region issue	12.2.0
12-2013	RP-62	RP-131928	1916r2		Allowed power reductions for multiple transmissions in a subframe	12.2.0
12-2013	RP-62	RP-131967	1917r1		The coexistence requirements between Band 39 and Band 3	12.2.0
12-2013	RP-62	RP-131967	1918r1		The Pcmx clauses restructured and removal of addition of $\Delta T_c$ to P-MPR	12.2.0
12-2013	RP-62	RP-131956	1919		Configured maximum output power for multiple TAG transmission	12.2.0
12-2013	RP-62	RP-131936	1927r1		Configured maximum output power for multiple TAG transmission	12.2.0

12-2013	RP-62	RP-131927	1934		CR on correction of FRC of power imbalance test	12.2.0
12-2013	RP-62	RP-131927	1937		UE-UE coexistence for Band 40	12.2.0
12-2013	RP-62	RP-131957	1955r1		Introduction of LTE Advanced intra-band contiguous Carrier Aggregation in Band 23 to TS 36.101	12.2.0
12-2013	RP-62	RP-131961	1956r1		Introduction of CA_3A-3A into TS 36.101	12.2.0
12-2013	RP-62	RP-131937	1957		CR Minimum requirement with Different Cell ID and Colliding CRS (with single NZP CSI-RS resource)	12.2.0
12-2013	RP-62	RP-131937	1958		CR Minimum requirement with Same Cell ID (with multiple NZP CSI-RS resources)	12.2.0
12-2013	RP-62	RP-131936	1962		Introduction of reference SNR-s for FelCIC demodulation performance requirements	12.2.0
12-2013	RP-62	RP-131938	1964		OCNG pattern for EPDCCH test	12.2.0
12-2013	RP-62	RP-131931	1965		CA performance requirements for TDD intra-band NC CA	12.2.0
12-2013	RP-62	RP-131958	1966r1		CA performance requirements for TDD intra-band NC CA	12.2.0
12-2013	RP-62	RP-131939	1968		Introduction of UE TM3 demodulation performance requirements under ETU300	12.2.0
12-2013	RP-62	RP-131937	1970		Introduction of test 1-A for CoMP	12.2.0
12-2013	RP-62	RP-131939	1972		Modification of TM9 test to verify correct SNR estimation	12.2.0
12-2013	RP-62	RP-131928	1984		Correction to blocking requirements and use of Delta_RIB	12.2.0
12-2013	RP-62	RP-131950	1985		Introduction of CA band combination Band5 + Band25 to TS 36.101	12.2.0
12-2013	RP-62	RP-131939	1988r1		CR on test point clarification for CA demodulation test	12.2.0
12-2013	RP-62	RP-131937	1994		CR to Introduce fading CQI test for CoMP (TDD)	12.2.0
12-2013	RP-62	RP-131937	1996		CR to Introduce channel model for CoMP fading CQI tests	12.2.0
12-2013	RP-62	RP-131937	1998		CR to Introduce RI test for CoMP (FDD)	12.2.0
12-2013	RP-62	RP-131938	2001r1		Distributed EPDCCH Demodulation Test	12.2.0
12-2013	RP-62	RP-131938	2003r1		Localized EPDCCH Demodulation Test	12.2.0
12-2013	RP-62	RP-131938	2005r1		Localized EPDCCH Demodulation Test	12.2.0
12-2013	RP-62	RP-131937	2007		Introduction of DL CoMP FDD static CQI test	12.2.0
12-2013	RP-62	RP-131937	2009		Introduction of DL CoMP TDD static CQI test	12.2.0
12-2013	RP-62	RP-131924	2014		P-max for Band 38 to Band 7 coexistence	12.2.0
12-2013	RP-62	RP-131948	2015		Introduction of CA band combination B5 + B7 to TS 36.101	12.2.0
12-2013	RP-62	RP-131952	2017		Introduction of CA band combination B7 + B28 to TS 36.101	12.2.0
12-2013	RP-62	RP-131937	2024		Minimum requirement with Same Cell ID (with multiple NZP CSI-RS resources) TDD	12.2.0
12-2013	RP-62	RP-131937	2026		CR Minimum requirement with Different Cell ID and Colliding CRS (with single NZP CSI-RS resource) TDD	12.2.0
12-2013	RP-62	RP-131936	2028		Editorial change on FelCIC PBCH Noc setup	12.2.0
12-2013	RP-62	RP-131937	2032		Introduction of test 1-A for CoMP	12.2.0
12-2013	RP-62	RP-131931	2035r1		Correction of nominal guard bands for bandwidth classes A, B and C	12.2.0
12-2013	RP-62	RP-131937	2042		CR to Introduce RI test for CoMP (TDD)	12.2.0
12-2013	RP-62	RP-131937	2043		CR to Introduce fading CQI test for CoMP (FDD)	12.2.0
12-2013	RP-62	RP-131931	2045		Correction of TDD PCFICH/PDCCH test parameter table	12.2.0
12-2013	RP-62	RP-131939	2047		Add EVA200 to table of channel model parameters	12.2.0
12-2013	RP-62	RP-131963	2050r1		Introduction of CA_7A-7A into TS 36.101	12.2.0
12-2013	RP-62	RP-131967	2057		Band 41 deployment in Japan	12.2.0
12-2013	RP-62	RP-131926	2059		CA_1C: Correction on CA_NS_02 A-MPR table	12.2.0
12-2013	RP-62	RP-131924	2060		Simplification of Band 12/17 in-band blocking test cases	12.2.0
12-2013	RP-62	RP-131967	2064		Correction of duplicated notes on table 7.3.1A-3	12.2.0
12-2013	RP-62	RP-131938	2066		Introduction of EPDCCH TM10 localized test R-12	12.2.0
12-2013	RP-62	RP-131938	2068		Introduction of SDR test for PDSCH with EPDCCH scheduling	12.2.0
03-2014	RP-63	RP-140377	2115		Editorial Correction for TS36.101 Rel-12	12.3.0
03-2014	RP-63	RP-140371	2108		UL-DL configuration and other parameters for FelCIC TDD CQI fading test (Rel-12)	12.3.0
03-2014	RP-63	RP-140374	2097		CR on TM9 localized ePDCCH test	12.3.0
03-2014	RP-63	RP-140374	2101		CR on reference measurement channel for ePDCCH test	12.3.0
03-2014	RP-63	RP-140371	2110		CR for TS36.101 COMP demodulation requirements	12.3.0
03-2014	RP-63	RP-140371	2113		CR for Combinations of channel model parameters	12.3.0
03-2014	RP-63	RP-140374	2114		CR for EPDCCH power allocation (Rel-12)	12.3.0
03-2014	RP-63	RP-140371	2106		Cleanup of the specification for FelCIC (Rel-12)	12.3.0
03-2014	RP-63	RP-140375	2089		CR for introduction of 15MHz based single carrier and CA SDR tests in Rel-12	12.3.0
03-2014	RP-63	RP-140375	2080r1		CR on TM3 demodulation and soft buffer management test	12.3.0

03-2014	RP-63	RP-140371	2086		CR on reference measurement channel for TM10 PDSCH demodulation test	12.3.0
03-2014	RP-63	RP-140241	2174		Introduction of 3MHz in Band 8 for CA_8_20 RF requirements into TS36.101	12.3.0
03-2014	RP-63	RP-140417	2173r 1		Addition of bandwidth combination set for CA_2A-29A and CA_4A-29A	12.3.0
03-2014	RP-63	RP-140387	2071r 1		Introduction of TDD inter-band CA_B39_B41 into 36.101	12.3.0
03-2014	RP-63	RP-140378	2069		CA_3C is adding 100RB+75RB uplink configuration for reference sensitivity	12.3.0
03-2014	RP-63	RP-140388	2070		CR for TS36.101 on CA_C_B39	12.3.0
03-2014	RP-63	RP-140386	2072		Introduction of CA band B3+B27 to TS36.101	12.3.0
03-2014	RP-63	RP-140374	2074		CR of EPDCCH localized test with TM10 QCL Type-B configuration (Rel-12)	12.3.0
03-2014	RP-63	RP-140371	2142		Clarification of contiguous and non-contiguous intra-band UE capabilities in the same band	12.3.0
03-2014	RP-63	RP-140385	2161		Introduction of additional bandwidth combination set for CA_2A-4A	12.3.0
03-2014	RP-63	RP-140371	2131r 1		CR to finalize RI test for CoMP	12.3.0
03-2014	RP-63	RP-140368	2147		Correction of coding rate for 18RBs in UL RMC table	12.3.0
03-2014	RP-63	RP-140371	2144		Channel spacing for non-contiguous intra-band carrier aggregation	12.3.0
03-2014	RP-63	RP-140374	2163		Distributed EPDCCH Demodulation Test	12.3.0
03-2014	RP-63	RP-140368	2137		Configured transmitted power for CA	12.3.0
03-2014	RP-63	RP-140368	2122		CR for 36.101. Editorial correction on OCNG pattern	12.3.0
03-2014	RP-63	RP-140370	2160		Correction of table notes for NS_12-NS_15 spurious emissions requirements	12.3.0
03-2014	RP-63	RP-140371	2129r 1		CR to finalize fading CQI test for CoMP	12.3.0
03-2014	RP-63	RP-140375	2119		Introduction of requirements for SNR test for TM9	12.3.0
03-2014	RP-63	RP-140374	2125		CR on correction of downlink SDR tests with EPDCCH scheduling	12.3.0
03-2014	RP-63	RP-140371	2127		Correction on DL CoMP static CQI tests (Rel 12)	12.3.0
06-2014	RP-64	RP-140909	2177r 3		RF: Corrections to spurious emission requirements with NS different than NS_01 (Rel-12)	12.4.0
06-2014	RP-64	RP-140932	2187r 1		Additional bandwidth combination set for LTE Advanced inter-band Carrier Aggregation of Band 3 and Band 20	12.4.0
06-2014	RP-64	RP-140934	2188		Additional bandwidth combination set for LTE Advanced inter-band Carrier Aggregation of Band 7 and Band 20	12.4.0
06-2014	RP-64	RP-140943	2195r 1		CR for TS 36.101 on introduction CA_41D	12.4.0
06-2014	RP-64	RP-140943	2196r 3		CR to TS 36.101 on introduction of CA BW class D requirements	12.4.0
06-2014	RP-64	RP-140918	2198		CR on correction on TDD IRC CQI test	12.4.0
06-2014	RP-64	RP-140917	2207		CR of EPDCCH localized test with TM10 QCL Type-B configuration (Rel-12): correction of CSI-RS configurations	12.4.0
06-2014	RP-64	RP-140918	2209		Clean up of TM9 SNR tests	12.4.0
06-2014	RP-64	RP-140933	2210r 1		Introduction of band B4+B27 CA to TS36.101	12.4.0
06-2014	RP-64	RP-140942	2213		Introduction of CA band combination B1+B20 to TS 36.101	12.4.0
06-2014	RP-64	RP-140917	2216		CR for EPDCCH test (Rel-12)	12.4.0
06-2014	RP-64	RP-140914	2218		CR of modification on FeICIC rank testing (Rel-12)	12.4.0
06-2014	RP-64	RP-140914	2220		CR on FeICIC PBCH performance requirement (Rel-12)	12.4.0
06-2014	RP-64	RP-140918	2222		Correction on out-of-band blocking for CA	12.4.0
06-2014	RP-64	RP-140918	2226		Update demodulation performance requirements with new UE categories	12.4.0
06-2014	RP-64	RP-140911	2228		Correction for CA sustained data rate test (Rel-12)	12.4.0
06-2014	RP-64	RP-140945	2229		Correction on wrong annotation for close-loop spatial multiplexing performance	12.4.0
06-2014	RP-64	RP-140911	2233		Clarification of Intra-band contiguous CA class C Narrow band blocking requirements	12.4.0
06-2014	RP-64	RP-140911	2239		Correction for CA soft buffer test (Rel-12)	12.4.0
06-2014	RP-64	RP-140918	2241		CR on OCNG and propagation conditions for dual layer TM9 test (Rel-12)	12.4.0
06-2014	RP-64	RP-140911	2247		Remove [ ] from eICIC TDD RI requirement	12.4.0
06-2014	RP-64	RP-140914	2256		Verification of exceptions of REFSENS requirements for carrier aggregation	12.4.0
06-2014	RP-64	RP-140914	2258		Applicability of exceptions to reference sensitivity requirements for CA	12.4.0
06-2014	RP-64	RP-140909	2269		In-band blocking case numbering re-establishment	12.4.0
06-2014	RP-64	RP-140918	2273		CR for TS36.101 FRC tables for COMP demodulation requirements	12.4.0
06-2014	RP-64	RP-140945	2277		Editorial correction of note in clause 4.4	12.4.0

06-2014	RP-64	RP-140926	2282r 1		Editorial correction of note in clause 4.4	12.4.0
06-2014	RP-64	RP-140911	2283		Introduction of new bandwidth combination set for CA_1A-5A UE	12.4.0
06-2014	RP-64	RP-140914	2286		CR for finalizing DL CoMP CSI reporting requirements	12.4.0
06-2014	RP-64	RP-140914	2288		CR for adding DL CoMP CSI RMC tables (Rel-12)	12.4.0
06-2014	RP-64	RP-140921	2291		Simplification of 36.101 Table 5.6A.1-1 for LTE_CA_C_B27	12.4.0
06-2014	RP-64	RP-140914	2293		Finalization of CoMP demodulation test cases	12.4.0
06-2014	RP-64	RP-140918	2294		Editorial corrections for UE performance requirements for R12	12.4.0
06-2014	RP-64	RP-140937	2295		Introduction of CA performance requirements for Band 27 CA	12.4.0
06-2014	RP-64	RP-140931	2296		Introduction of CA 1+11 to 36.101 (Rel-12)	12.4.0
06-2014	RP-64	RP-140994	2309		Inclusion of the out of band emission limit concluded in CEPT into band 28	12.4.0
06-2014	RP-64	RP-140911	2314		UE to UE co-existence between B42/B43	12.4.0
06-2014	RP-64	RP-140911	2318		Perf: Corrections to CA (Class C) performance with power imbalance (Rel-12)	12.4.0
06-2014	RP-64	RP-140920	2319		Introduction of CA performance requirements for Band 23 CA	12.4.0
06-2014	RP-64	RP-140914	2321		CR of modification on FeICIC rank testing (Rel-12)	12.4.0
06-2014	RP-64	RP-140914	2323		CR of introducing FeICIC TM9 testing (Rel-12)	12.4.0
06-2014	RP-64	RP-140917	2325		CR for EPDCCH SDR test (Rel-12)	12.4.0
06-2014	RP-64	RP-140911	2328		Clean-up CR for demodulation requirements (Rel-12)	12.4.0
06-2014	RP-64	RP-140945	2330r 1		Additional updates of UE categories for demodulation performance requirements (Rel-12)	12.4.0
06-2014	RP-64	RP-140911	2333		Throughput calculation for eICIC demodulation requirements	12.4.0
06-2014	RP-64	RP-140914	2335r 1		Introduction of Band 28 requirements for flexible operation in Japan	12.4.0
06-2014	RP-64	RP-140911	2337r 1		Add missing Uplink downlink configuration to eICIC TDD RI requirement	12.4.0
06-2014	RP-64	RP-140945	2338		Add static propagation condition matrix for 1 x 2	12.4.0
06-2014	RP-64	RP-140911	2341		Cleanup of terminology for Rx requirements	12.4.0
06-2014	RP-64	RP-140945	2344		CR on separating CA UE demodulation tests from single carrier tests in Rel-12	12.4.0
06-2014	RP-64	RP-140911	2351		Test configuration for intra-band contiguous carrier aggregation power control	12.4.0
06-2014	RP-64	RP-140935	2358		Addition of bandwidth combination sets for CA_2A-29A, CA_3A-5A, CA_4A-5A, CA_4A-12A, and CA_4A-29A into 36.101	12.4.0
06-2014	RP-64	RP-140914	2362		Correction of test configurations for intra-band non-contiguous aggregation	12.4.0
06-2014	RP-64	RP-140911	2365		Clarification on CA bandwidth classes	12.4.0
06-2014	RP-64	RP-140917	2374		CR on correction of downlink SDR tests with EPDCCH scheduling	12.4.0
06-2014	RP-64	RP-140922	2377		Correction on LTE_CA_C_B39	12.4.0
06-2014	RP-64	RP-140911	2378		Corrections on CA CQI tests	12.4.0
06-2014	RP-64	RP-140930	2381r 1		Introduction of LTE-Advanced CA of Band 8 and Band 40 to TS36.101	12.4.0
06-2014	RP-64	RP-140927	2382r 1		FRC for DL MIMO enhancement PMI requirements	12.4.0
06-2014	RP-64	RP-140603	2384r 2		CR for TS 36.101 on introduction CA_40D	12.4.0
06-2014	RP-64	RP-140944	2385r 1		CR to TS 36.101 on introduction of 3DL intra-band non-contiguous CA requirements	12.4.0
06-2014	RP-64	RP-140938	2387		Introduction of CA_2A-2A into TS 36.101	12.4.0
06-2014	RP-64	RP-140927	2392		Introduction of 4Tx beam steering model	12.4.0
06-2014	RP-64	RP-140914	2394		CA_7C A-MPR Corrections	12.4.0
06-2014	RP-64	RP-140936	2395r 2		Introduction of a new CA_7C bandwidth combination set into 36.101	12.4.0
06-2014	RP-64	RP-140918	2398		CR for TS36.101 CSI RMC table	12.4.0
06-2014	RP-64	RP-140940	2413		Introduction of LTE_CA_NC_B42 into 36.101	12.4.0
06-2014	RP-64	RP-140942	2420		Introduction of CA band combination B1+B20 to TS 36.101	12.4.0
06-2014	RP-64	RP-140919	2422		CA_3C is deleting 75RB+75RB uplink configuration for reference sensitivity	12.4.0
06-2014	RP-64	RP-140914	2425		CR on correction for TM10 CSI reporting requirements	12.4.0
09-2014	RP-65	RP-141197	2458r 1		Introduction of CA_B1_B3_B19 into TS 36.101	12.5.0
09-2014	RP-65	RP-141428	2568		Updated REFSENS requirements for band combinations with Band 4 and Band 12	12.5.0
09-2014	RP-65	RP-141468	2508r 1		Introduction of 3 DL CA for Band 1+3+20	12.5.0
09-2014	RP-65	RP-141469	2571		Correction to CA in Band 1+20	12.5.0

09-2014	RP-65	RP-141525	2504r1		Perf: Cleanup and better description of DL-RMC-s with dynamic coding rate for CSI requirements (Rel-12)	12.5.0
09-2014	RP-65	RP-141525	2565		Corrections to UE coex table	12.5.0
09-2014	RP-65	RP-141527	2434		Correction on support of a bandwidth combination set	12.5.0
09-2014	RP-65	RP-141527	2452r1		Remove the redundant table for FDD 4Tx multi-layer tests and correct the test case number (Rel-12)	12.5.0
09-2014	RP-65	RP-141527	2466		Unequal DL CC RB allocations in Maximum input level	12.5.0
09-2014	RP-65	RP-141527	2469		Intra-band contiguous CA ACS case 2 test clarification	12.5.0
09-2014	RP-65	RP-141527	2484		Corrections on delta Tc for UE MOP for intra-band contiguous CA	12.5.0
09-2014	RP-65	RP-141527	2487		Removal of Class B in UE TX requirement	12.5.0
09-2014	RP-65	RP-141527	2516r1		CR for CA applicability rule in 36.101 in Rel-12	12.5.0
09-2014	RP-65	RP-141527	2519r1		Editorial CR for CA performance tests in 36.101 in Rel-12	12.5.0
09-2014	RP-65	RP-141527	2548		Correction to NS_20 A-MPR for Band 23	12.5.0
09-2014	RP-65	RP-141530	2447		CR of introducing FeICIC TM9 testing (Rel-12)	12.5.0
09-2014	RP-65	RP-141530	2454		Maintenance of CoMP demodulation performance requirements (Rel-12)	12.5.0
09-2014	RP-65	RP-141530	2456		Clean-up CR for EPDCCCH and FeICIC PBCH (Rel-12)	12.5.0
09-2014	RP-65	RP-141530	2471		Throughput calculation for feICIC demodulation requirements	12.5.0
09-2014	RP-65	RP-141532	2439		CR on correction on CQI reporting TDD CSI meas in case two CSI subframe sets with CRS test (Rel-12)	12.5.0
09-2014	RP-65	RP-141532	2441		CR on correction on RI reporting CSI meas in case two CSI subframe sets with CRS tests (Rel-12)	12.5.0
09-2014	RP-65	RP-141532	2444		Clarification of high speed train scenario in 36.101 (Rel-12)	12.5.0
09-2014	RP-65	RP-141532	2478		CQI reporting under fading: CQI indices in set	12.5.0
09-2014	RP-65	RP-141532	2490		Correction on A-MPR table	12.5.0
09-2014	RP-65	RP-141532	2499		RF: Corrections to spurious emission band co-existence requirement for Band 44	12.5.0
09-2014	RP-65	RP-141535	2559		Addition of E-UTRA CA configurations and bandwidth combination sets defined for inter-band CA for Band 4 and 27	12.5.0
09-2014	RP-65	RP-141537	2541		Band 42 contiguous CA channel bandwidth correction	12.5.0
09-2014	RP-65	RP-141546	2463r1		Introduction of PMI reporting requirements for DL MIMO enhancement	12.5.0
09-2014	RP-65	RP-141548	2457r2		Introduction of CA_B1_B3 into TS 36.101	12.5.0
09-2014	RP-65	RP-141549	2556		Addition of bandwidth combination set for CA_2A-4A	12.5.0
09-2014	RP-65	RP-141550	2566		Addition of 3MHz bandwidth for Band 12, in the B2+B12 CA combination	12.5.0
09-2014	RP-65	RP-141551	2445		Introduction of CA 8+11 to 36.101 (Rel-12)	12.5.0
09-2014	RP-65	RP-141553	2491r1		Introduction of a new bandwidth combination set for CA_25A-25A into 36.101	12.5.0
09-2014	RP-65	RP-141554	2533r1		Introduction of requirements for 3DL inter-band carrier aggregation (FDD)	12.5.0
09-2014	RP-65	RP-141554	2534		Introduction of requirements for 3DL combinations with Band 30 (FDD)	12.5.0
09-2014	RP-65	RP-141557	2461r1		Introduction of CA_B19_B42_B42 into TS 36.101	12.5.0
09-2014	RP-65	RP-141559	2460r1		Introduction of CA_B1_B42_B42 into TS 36.101	12.5.0
09-2014	RP-65	RP-141560	2427		Adding 15MHz channel BW to B40 3DL and new bandwidth combination set for the 2DL	12.5.0
09-2014	RP-65	RP-141561	2488r1		Corrections on Maximum input level for intra-band non-contiguous 3DL	12.5.0
09-2014	RP-65	RP-141562	2436		Corrections on Maximum input level and ACS for intra-band CA	12.5.0
09-2014	RP-65	RP-141562	2481r1		Introduction of CA band combination B41+ B42 to TS 36.101	12.5.0
09-2014	RP-65	RP-141562	2522		CR on CA power imbalance tests in Rel-12	12.5.0
09-2014	RP-65	RP-141562	2560		CR Reducing MPR for Contiguous CA with Non-Contiguous Resource Allocations	12.5.0
09-2014	RP-65	RP-141563	2555r1		UL configuration for CA_4A-12A reference sensitivity	12.5.0
09-2014	RP-65	RP-141563	2557		Addition of bandwidth combination set for CA_4A-12A	12.5.0
09-2014	RP-65	RP-141612	2494r2		Introduction of inter-band CA_18-28 into TS36.101	12.5.0
09-2014	RP-65	RP-141635	2552r2		Introduction of CA_1A-7A into 36.101(Rel-12)	12.5.0
09-2014	RP-65	RP-141636	2480r2		Introduction of 3DLs CA band combination of Band1 +5 + 7 to TS 36.101 Rel-12	12.5.0
09-2014	RP-65	RP-141653	2435r3		Introduction of 3 Band Carrier Aggregation (3DL/1UL) of Band 1, Band 3 and Band 8 to TS 36.101	12.5.0

09-2014	RP-65	RP-141682	2570r1		Introduction of CA band combination B1+B7+B20 to TS 36.101	12.5.0
09-2014	RP-65	RP-141708	2492r3		Introduction of 3 Band Carrier Aggregation of Band 1, Band 3 and Band 5 to TS 36.101	12.5.0
12-2014	RP-66	RP-142147	2671		Correction of CoMP TDD CSI tests (Rel-12)	12.6.0
12-2014	RP-66	RP-142144	2574		CR for REFSENSE in lower SNR and change history	12.6.0
12-2014	RP-66	RP-142173	2581		CR on 4Tx codebook PMI testing	12.6.0
12-2014	RP-66	RP-142142	2587		CR for 1 PRB allocation performance in presence of MBSFN (rel-12)	12.6.0
12-2014	RP-66	RP-142144	2590		Maintenance of CA demodulation performance requirements (Rel-12)	12.6.0
12-2014	RP-66	RP-142147	2592		Clean up for FeICIC demodulation performance requirements (Rel-12)	12.6.0
12-2014	RP-66	RP-142166	2600		Correction of placement of CA_40D in Table	12.6.0
12-2014	RP-66	RP-142162	2601		CQI test for TDD CL_C 20MHz+15MHz in Rel-12	12.6.0
12-2014	RP-66	RP-142162	2602		Sustained downlink data rate test for TDD CL_C 20MHz+15MHz in Rel-12	12.6.0
12-2014	RP-66	RP-142165	2611		Removal of square brackets for CA_B1_B3 and CA_B1_B3_B19	12.6.0
12-2014	RP-66	RP-142147	2620		CQI reporting in AWGN: CQI indices in set	12.6.0
12-2014	RP-66	RP-142147	2629		CR to fix error of CA capability for CA performance tests in 36.101 in Rel-12	12.6.0
12-2014	RP-66	RP-142144	2637		Definition of the bits in the bitmap for indication of modified MPR behavior	12.6.0
12-2014	RP-66	RP-142147	2641		Applicability of in-gap and out-of-gap measurements for intra-band NC CA	12.6.0
12-2014	RP-66	RP-142183	2642		Introduction of additional bandwidth combination set for CA_2A-5A	12.6.0
12-2014	RP-66	RP-142164	2643		Corrections for 3DL inter-band CA band combinations	12.6.0
12-2014	RP-66	RP-142147	2661		Maintenance of TM10 demodulation test configurations on PQI set and ZP-CSIRS ( Rel-12 test 8.3.1.3.2, 8.3.2.4.2 )	12.6.0
12-2014	RP-66	RP-142173	2582r1		Introduction of PUSCH 3-2 requirements into TS36.101	12.6.0
12-2014	RP-66	RP-142162	2603r1		Normal demodulation test for TDD CL_C 20MHz+15MHz in Rel-12	12.6.0
12-2014	RP-66	RP-142164	2576r1		Corrections on Out-of-band blocking requirements for CA Class B and D	12.6.0
12-2014	RP-66	RP-142149	2678		CR to specify applicability of CoMP RI test (Rel-12)	12.6.0
12-2014	RP-66	RP-142144	2688		Removal of bracket for UL MIMO	12.6.0
12-2014	RP-66	RP-142164	2689		Corection of B29 REFSENS for CA_2A-29A-30A and CA_4A-29A-30A	12.6.0
12-2014	RP-66	RP-142144	2700		Delete the incorrect notes for FDD DMRS demodulation tests (Rel-12)	12.6.0
12-2014	RP-66	RP-142160	2594r3		Correcting requirements for inter-band CA_18-28 in TS36.101	12.6.0
12-2014	RP-66	RP-142173	2705		CR of modification on PMI reporting requirements for DL MIMO enhancement	12.6.0
12-2014	RP-66	RP-142144	2720		Band 22 correction in UE to UE co-existence table.	12.6.0
12-2014	RP-66	RP-142147	2722		Correction to non-contiguous downlink intraband CA receiver requirements	12.6.0
12-2014	RP-66	RP-142159	2752		Removal of dBm from CA_1A-7A	12.6.0
12-2014	RP-66	RP-142147	2723		Correction to table format of allowed channel bandwidths of non-contiguous intraband CA	12.6.0
12-2014	RP-66	RP-142164	2643r1		Corrections for 3DL inter-band CA band combinations	12.6.0
12-2014	RP-66	RP-142146	2731		Modifications for NS_12 and NS_13	12.6.0
12-2014	RP-66	RP-142189	2739		Introduction of CA_5-13 into 36.101	12.6.0
12-2014	RP-66	RP-142173	2706r1		CR of reference measurement channel for PUSCH3-2 test	12.6.0
12-2014	RP-66	RP-142144	2727r1		CR for CA applicability rule in 36.101 in Rel-12	12.6.0
12-2014	RP-66	RP-142188	2676r1		CR to remove CA capability column in CA performance test tables (Rel-12)	12.6.0
12-2014	RP-66	RP-142173	r3		Introduction of PUSCH 3-2 requirements into TS36.101	12.6.0
12-2014	RP-66	RP-142187	2690r1		CR on sustained data rate test for 3DL CA	12.6.0
12-2014	RP-66	RP-142187	2681r2		CR on normal demodulation test for 3DL CA	12.6.0
12-2014	RP-66	RP-142147	2747r1		TS36.101 removal of brackets (RF)	12.6.0
12-2014	RP-66	RP-142144	2755		Correction to Transmit Modulation Quality for CA	12.6.0
12-2014	RP-66	RP-142144	2710r1		Clarification on UL and DL CA	12.6.0
12-2014	RP-66	RP-142144	2717r1		Clarification of notes relating to interferer offsets in intraband CA receiver requirement tables.	12.6.0

12-2014	RP-66	RP-142147	2735r 1		Band 28 and NS_24	12.6.0
12-2014	RP-66	RP-142179	2684r 1		CR for UE requirements for 256QAM	12.6.0
12-2014	RP-66	RP-142180	2729r 1		Introduction of Dual Connectivity to TS 36.101 Rel-12, RF part	12.6.0
12-2014	RP-66	RP-142184	2680r 1		Introduction of dual uplink inter-band CA in TS 36.101 rel-12	12.6.0
12-2014	RP-66	RP-142182	2701r 1		Introduction of inter-band CA_1-28 into TS36.101	12.6.0
12-2014	RP-66	RP-142144	2758		Correction to Note 2 of Harmonic Signal Exceptions in Spurious Emissions	12.6.0
12-2014	RP-66	RP-142144	2751r 2		Removal of brackets and TBD from CA feature	12.6.0
12-2014	RP-66	RP-142144	2697r 1		Maintenance of CA performance requirements (Rel-12)	12.6.0
12-2014	RP-66	RP-142187	2679r 2		CR to introduce CQI test for 3 DL CA	12.6.0
12-2014	RP-66	RP-142185	2721r 1		Addition of 2UL non-contiguous intraband CA feature	12.6.0
12-2014	RP-66	RP-142144	2704r 2		UE to UE co-existence between B42/B43	12.6.0
12-2014	RP-66	RP-142176	2685r 2		Introduction of LC MTC into TS 36.101	12.6.0
12-2014	RP-66	RP-142190	2759r 1		Introduction of additional band combinations for 3DL inter-band CA	12.6.0
03-2015	RP-67	RP-150387	2760r 2		Introduce additional bands of LC MTC	12.7.0
03-2015	RP-67	RP-150387	2761		CR on corrections to Dual-Layer Spatial Multiplexing with multiple CSI-RS config Rel-12	12.7.0
03-2015	RP-67	RP-150392	2765r 1		CR for applicability and test rules for TDD-FDD CA performance requirements	12.7.0
03-2015	RP-67	RP-150392	2766		Introduction of CQI tests for TDD-FDD CA	12.7.0
03-2015	RP-67	RP-150395	2767r 1		CR to introduce the SU-MIMO whitening verification test	12.7.0
03-2015	RP-67	RP-150392	2768r 1		CR on power imbalance test for 3DL CA	12.7.0
03-2015	RP-67	RP-150392	2769		CR on sustained data rate test for TDD FDD CA	12.7.0
03-2015	RP-67	RP-150394	2770r 1		CR for introduction of 256QAM demodulation performance requirements	12.7.0
03-2015	RP-67	RP-150393	2772r 1		CR: DC UE performance requirements	12.7.0
03-2015	RP-67	RP-150390	2773r 1		CR: MTC demodulation performance requirements	12.7.0
03-2015	RP-67	RP-150390	2774r 1		CR: MTC CSI requirements	12.7.0
03-2015	RP-67	RP-150396	2775r 1		Introduction of the eIMTA functional PDSCH demodulation test	12.7.0
03-2015	RP-67	RP-150387	2776r 3		CR on RF core requirements for D2D	12.7.0
03-2015	RP-67	RP-150387	2777		Modification of CSI reference measurement channel Rel-12	12.7.0
03-2015	RP-67	RP-150388	2779		Editorial correction for CA_18A-28A	12.7.0
03-2015	RP-67	RP-150388	2781		Removing brackets for CA_1A-28A MSD requirements	12.7.0
03-2015	RP-67	RP-150384	2783		Editorial correction on symbols for enhanced performance requirements type A	12.7.0
03-2015	RP-67	RP-150387	2784		Corrections on reference measurement channel	12.7.0
03-2015	RP-67	RP-150388	2792		Correction of TS 36.101 for the Pcell support of 25+41	12.7.0
03-2015	RP-67	RP-150395	2793r 1		CR for single cell demodulation test for SU-MIMO	12.7.0
03-2015	RP-67	RP-150391	2794		Introduction of CA_3A-42A and CA_3A-42C into 36.101	12.7.0
03-2015	RP-67	RP-150384	2797		UL HARQ in PDSCH and PDCCH/PCFICH demod test cases for eICIC/feICIC with MBSFN ABS	12.7.0
03-2015	RP-67	RP-150382	2800		Correction to eICIC aggressor cell configurations	12.7.0
03-2015	RP-67	RP-150387	2801		R4-73AH-0040: Correction for uplink CA configuration in TS 36.101 Rel-12	12.7.0
03-2015	RP-67	RP-150387	2802r 1		Correction of MSD levels for CA_1A-8A in TS 36.101 rel-12	12.7.0
03-2015	RP-67	RP-150387	2805		Removal of eDL-MIMO term from specification	12.7.0
03-2015	RP-67	RP-150388	2809		Clarification of 2UL/3DL contiguous intraband CA REFSSENS test	12.7.0
03-2015	RP-67	RP-150392	2811r 1		CR on TM4 normal demodulation test for 3DL CA	12.7.0
03-2015	RP-67	RP-150392	2812		CR on introducing new DL reference measurement channels	12.7.0
03-2015	RP-67	RP-150392	2813r 1		CR on normal demodulation test for TDD-FDD CA	12.7.0

03-2015	RP-67	RP-150388	2815		Additions of bandwidth combination set reference	12.7.0
03-2015	RP-67	RP-150388	2816		Correction of band number in Table 5.6A.1-2a for LTE_CA_B4_B12_B30	12.7.0
03-2015	RP-67	RP-150382	2819		UE to UE co-existence between B42/B43	12.7.0
03-2015	RP-67	RP-150382	2822		Corrections to CA in-band emissions requirement	12.7.0
03-2015	RP-67	RP-150381	2830		Uplink RMCs for sustained data rate test	12.7.0
03-2015	RP-67	RP-150382	2833		Corrections to the CA power imbalance test	12.7.0
03-2015	RP-67	RP-150392	2839r1		CR for soft buffer tests for TDD-FDD CA in 36.101 in Rel-12	12.7.0
03-2015	RP-67	RP-150392	2842		Editorial CR for CA UE performance tests in 36.101 in Rel-12	12.7.0
03-2015	RP-67	RP-150387	2847		UE spurious emissions structure correction for CA	12.7.0
03-2015	RP-67	RP-150387	2850		Correction of PCMAX for uplink inter-band and intra-band carrier aggregation	12.7.0
03-2015	RP-67	RP-150387	2851		Exceptions for spurious response for UL CA	12.7.0
03-2015	RP-67	RP-150388	2852r1		Correction of REFSSENS, OOB and uplink configuration for 3DL/1UL CA	12.7.0
03-2015	RP-67	RP-150390	2853		SNR definition for category 0 UE	12.7.0
03-2015	RP-67	RP-150390	2854r1		FRC for category 0 UE PDSCH performance requirements	12.7.0
03-2015	RP-67	RP-150390	2855r1		Introduction of new PHICH and PBCH performance requirements for category 0 UE	12.7.0
03-2015	RP-67	RP-150387	2861		Correction to FOOB reference in definition of MPR for contiguous CA with non-contiguous resource allocation	12.7.0
03-2015	RP-67	RP-150387	2862		Band 31 update	12.7.0
03-2015	RP-67	RP-150384	2867		Implementation of CA configurations specified in later releases	12.7.0
06-2015	RP-68	RP-150958	2870r2		Intra-band contiguous CA reference sensitivity definition for Class D	12.8.0
06-2015	RP-68	RP-150961	2881r2		CR on MTC CQI tests	12.8.0
06-2015	RP-68	RP-150962	2882r2		CR on 256QAM demodulation performance requirements	12.8.0
06-2015	RP-68	RP-150962	2883r3		CR on 256QAM sustained data rate tests for single carrier and TDD or FDD CA	12.8.0
06-2015	RP-68	RP-150962	2885r4		CR on 256QAM CQI test	12.8.0
06-2015	RP-68	RP-150963	2886r3		CR on DC SDR tests	12.8.0
06-2015	RP-68	RP-150963	2887r2		Maintenance CR for DC demodulation performance requirements	12.8.0
06-2015	RP-68	RP-150958	2888		CR to restore R.10-2 FDD	12.8.0
06-2015	RP-68	RP-150961	2889r3		Introduction of UE category 0 PDSCH/PHICH/PBCH performance requirements	12.8.0
06-2015	RP-68	RP-150954	2901		UE to UE co-existence between B42/B43	12.8.0
06-2015	RP-68	RP-150958	2902		Correction of maximum aggregated bandwidth for CA_26A-41A	12.8.0
06-2015	RP-68	RP-150957	2903r2		Introduction of TDD SU-MIMO whitening verification test	12.8.0
06-2015	RP-68	RP-150958	2904		Correction of FRC table for CA demodulation with power imbalance	12.8.0
06-2015	RP-68	RP-150958	2905r1		Add SCell power levels for 2DL CA power imbalance test	12.8.0
06-2015	RP-68	RP-150955	2907		Corrections on UL transmit power for CA receiver requirements	12.8.0
06-2015	RP-68	RP-150958	2909		Corrections to the CA power imbalance test	12.8.0
06-2015	RP-68	RP-150957	2910r1		Clarification on RMC for D2D UE	12.8.0
06-2015	RP-68	RP-150960	2911		Correction on TDD eIMTA PDSCH functionality test	12.8.0
06-2015	RP-68	RP-150954	2931		3.5 GHz out-of-band blocking	12.8.0
06-2015	RP-68	RP-150965	2933		Correction of FRC names	12.8.0
06-2015	RP-68	RP-150954	2936		Correction of the 3DL CA REFSSENS	12.8.0
06-2015	RP-68	RP-150962	2939r1		CR on 256QAM sustained data rate tests for TDD FDD CA	12.8.0
06-2015	RP-68	RP-150958	2940r1		Maintenance CR for 3DL CA performance requirements	12.8.0
06-2015	RP-68	RP-150958	2941r1		Maintenance CR for TDD FDD CA demodulation performance requirements	12.8.0
06-2015	RP-68	RP-150965	2944		Corrections on 2UL intra-band non-contiguous CA requirements	12.8.0
06-2015	RP-68	RP-150958	2947		Updates to the definitions of CA capability (Rel-12)	12.8.0
06-2015	RP-68	RP-150955	2950		Clarification of PDSCH allocation in CSI PUSCH 3-0 feICIC tests (Rel-12)	12.8.0
06-2015	RP-68	RP-150954	2956		NS value for intra-band contiguous CA configurations not allowed A-MPR	12.8.0



06-2015	RP-68	RP-150957	2958		Receiver spurious emissions requirements for downlink-only bands	12.8.0
06-2015	RP-68	RP-150958	2959		Amendments to MPR for uplink inter-band and intra-band non-contiguous CA	12.8.0
06-2015	RP-68	RP-150958	2960r1		NS values for secondary cells of non-contiguous CA configurations	12.8.0
06-2015	RP-68	RP-150955	2961r1		Corrections to test configurations for intra-band non-contiguous CA	12.8.0
06-2015	RP-68	RP-150954	2962		Corrections to test configurations for 3DL inter-band CA	12.8.0
06-2015	RP-68	RP-150958	2967		Adding REFSENS exception requirements for 1+3+26	12.8.0
06-2015	RP-68	RP-150954	2971		Corrections to NS_22 and NS_23	12.8.0
06-2015	RP-68	RP-150958	2972		Corrections to 41D fallback	12.8.0
06-2015	RP-68	RP-150957	2972		Corrections to EVM requirements for ProSe and Annex F of 36.101	12.8.0
06-2015	RP-68	RP-150958	2976		Removal of B27 from 2UL CA_7A_20A co-existence protected band list	12.8.0
06-2015	RP-68	RP-150957	2977r1		CR on corrections to D2D RF core requirements	12.8.0
06-2015	RP-68	RP-150963	2978r1		CR on corrections to D2D RF core requirements	12.8.0
06-2015	RP-68	RP-150957	2979		CR clarification of RMC for DL category 0 UE HD-FDD	12.8.0
06-2015	RP-68	RP-150960	2980r1		Introduction of TDD eIMTA CQI requirement	12.8.0
06-2015	RP-68	RP-150958	2985		Change of 1.4MHz single carrier SNR values for multiple CA configurations	12.8.0
06-2015	RP-68	RP-150954	2992		Clarification to spurious emission requirement for the edge of spurious domain	12.8.0
06-2015	RP-68	RP-150955	2996		Correction to CA_7C A-MPR in CA-NS_06	12.8.0
06-2015	RP-68	RP-150965	2998r1		CR to update UE performance tests for UE DL category in 36.101 in Rel-12	12.8.0
06-2015	RP-68	RP-150965	2999		CR to update Annex for new DL category in 36.101 in Rel-12	12.8.0
06-2015	RP-68	RP-150958	3002		CR for updating CA applicability rule in 36.101 in Rel-12	12.8.0
06-2015	RP-68	RP-150957	3005r1		CR for Rel-12 NAICS - Definitions	12.8.0
06-2015	RP-68	RP-150965	3012r1		Clarification on uplink configuration for reference sensitivity of inter-band CA	12.8.0
06-2015	RP-68	RP-150954	3018		EVM for Intra-band contiguous UL CA for non-equal Channel BWs	12.8.0
06-2015	RP-68	RP-150958	3019		A-MPR correction for CA_39C CA_NS_07	12.8.0
06-2015	RP-68	RP-150958	2780r3		Introduction of dual uplink CA into 36.101	13.0.0
06-2015	RP-68	RP-150646	2785r2		Introduction of intra-band CA_42D to TS 36.101	13.0.0
06-2015	RP-68	RP-150968	2951r2		Introduction of additional 2DL inter-band CA	13.0.0
06-2015	RP-68	RP-150972	2952r1		Introduction of additional 3DL inter-band CA	13.0.0
06-2015	RP-68	RP-150974	2953r2		Introduction of 4DL inter-band CA	13.0.0
06-2015	RP-68	RP-150975	2994r1		Introduction of non-contiguous Carrier Aggregation (CA) in Band 42 for 3DL	13.0.0
06-2015	RP-68	RP-150967	3011r1		CR to 36.101: New CA bandwidth classes for FeCA	13.0.0
06-2015	RP-68	RP-150668	3021		Introduction of CA_3A-40A to TS 36.101	13.0.0
06-2015	RP-68	RP-150673	3022		Introduction of CA_3A-40C to TS 36.101	13.0.0
09-2015	RP-69	RP-151479	3028		Table 7.3.1A-0f (2UL CA MSD) notes numbering correction	13.1.0
09-2015	RP-69	RP-151505	3029		Additional bandwidth combination set for LTE Advanced intra-band non-contiguous Carrier Aggregation in Band 4	13.1.0
09-2015	RP-69	RP-151479	3031		Correction to TDD FDD CA	13.1.0
09-2015	RP-69	RP-151483	3033		Alignment of CA Receiver requirements parameters	13.1.0
09-2015	RP-69	RP-151476	3036		Correction to CoMP demodulation requirements	13.1.0
09-2015	RP-69	RP-151475	3040		Correction to RI test parameters in TS 36.101 (Rel-13)	13.1.0
09-2015	RP-69	RP-151475	3050		UE co-existence requirements between Band 42 and Japanese bands	13.1.0
09-2015	RP-69	RP-151483	3052		Introduction of relaxation rule for multiple 3DL inter-band CA configurations	13.1.0
09-2015	RP-69	RP-151491	3056r1		Adding CA_42D to the out of band blocking requirement exception	13.1.0
09-2015	RP-69	RP-151501	3057r1		Introduction of finished 4DL inter-band CAs to TS 36.101	13.1.0
09-2015	RP-69	RP-151487	3060r1		Corrections on CA reference sensitivity requirements	13.1.0
09-2015	RP-69	RP-151476	3064		Correction to RC.2 TDD Nr. HARQ Proc. into TS36.101	13.1.0

09-2015	RP-69	RP-151483	3065		Corrections to CSI PUCCH 1-0 static test 4 and PUSCH 3-2 tests	13.1.0
09-2015	RP-69	RP-151488	3066		Corrections in Table 5.6A.1-2, 7.3.1-1A and 7.3.1-1B.	13.1.0
09-2015	RP-69	RP-151479	3068		Corrections of Spurious emission band UE co-existence for interband 2UL CA in Table 6.6.3.2A-0	13.1.0
09-2015	RP-69	RP-151483	3070		Revisions of Spurious emission band UE co-existence in Table 6.6.3.2-1	13.1.0
09-2015	RP-69	RP-151475	3076		Correction to PDCCH/PCFICH test parameters in TS 36.101 (Rel-13)	13.1.0
09-2015	RP-69	RP-151475	3080		Correction to PMI delay in PMI test for TDD	13.1.0
09-2015	RP-69	RP-151503	3081r1		Introduction of dual uplink CA into 36.101	13.1.0
09-2015	RP-69	RP-151479	3083		Maintenance CR for MTC CSI performance requirements	13.1.0
09-2015	RP-69	RP-151479	3085		Maintenance CR for SCE demodulation and CSI requirements	13.1.0
09-2015	RP-69	RP-151479	3087		Maintenance CR for DC demodulation performance requirements and SDR tests	13.1.0
09-2015	RP-69	RP-151479	3089		Cleanup of TDD-FDD CA demodulation performance requirements	13.1.0
09-2015	RP-69	RP-151479	3091		Cleanup of R12 SU-MIMO Enhanced Performance Type C requirements	13.1.0
09-2015	RP-69	RP-151475	3102		Correction on UE maximum output power class of Band 22 for UL MIMO	13.1.0
09-2015	RP-69	RP-151479	3104		Removal of square brackets for Cat-0 UE demodulation requirements	13.1.0
09-2015	RP-69	RP-151479	3106		Removal of square brackets for LTE-CA B41 B42	13.1.0
09-2015	RP-69	RP-151490	3107		Removal of square brackets for LTE-CA B41 B42 B42	13.1.0
09-2015	RP-69	RP-151479	3112		Corrections on 3DL CA performance requirements	13.1.0
09-2015	RP-69	RP-151489	3113		CR 36.101 BW combination for CA_8A_41A	13.1.0
09-2015	RP-69	RP-151479	3114		UL DL pairing for CA of B39+B41+B41 and B39+B39+B41	13.1.0
09-2015	RP-69	RP-151498	3116		Introduction of additional band combinations for 2DL inter-band CA	13.1.0
09-2015	RP-69	RP-151499	3117		Introduction of additional band combinations for 3DL inter-band CA	13.1.0
09-2015	RP-69	RP-151475	3118		Minor corrections in 36.101	13.1.0
09-2015	RP-69	RP-151479	3121		CR adding clarification for Band 28 restrictions in 36.101	13.1.0
09-2015	RP-69	RP-151494	3123r1		Introduction of propagation conditions to handle 4 receivers in the UE	13.1.0
09-2015	RP-69	RP-151504	3125r1		Addition on interband CA 2UL/3DL pairs without MSD	13.1.0
09-2015	RP-69	RP-151483	3127		CR for UE performance tests for intra-band contiguous CA with minimum channel spacing on Band 41	13.1.0
09-2015	RP-69	RP-151496	3130r2		TM9 performance with CRS assistance information	13.1.0
09-2015	RP-69	RP-151495	3133r1		Introduction of UL 64QAM to TS 36.101	13.1.0
09-2015	RP-69	RP-151483	3135r1		Modification of test parameters for TM9 demodulation with 256QAM (Rel-13)	13.1.0
09-2015	RP-69	RP-151485	3137		CR to add demodulation tests for new release 13 2CC combinations in 36.101	13.1.0
09-2015	RP-69	RP-151501	3139r1		Introduction of 4CC demodulation requirements for FDD and FDD-TDD CA	13.1.0
09-2015	RP-69	RP-151479	3141		Correction to FDD-TDD closed loop spatial multiplexing 3CC requirement table	13.1.0
09-2015	RP-69	RP-151473	3143r1		Correction to DC supported testable bandwidth list	13.1.0
09-2015	RP-69	RP-151479	3145		Clarification of UL configuration for CA demodulation requirements	13.1.0
09-2015	RP-69	RP-151479	3146r1		Spreading of harmonic for 2UL interband and 2 ULnon-contiguous intraband CA	13.1.0
09-2015	RP-69	RP-151502	3147		Correction to dRib and REFSENS	13.1.0
09-2015	RP-69	RP-151479	3153		Corrections to CSI RMCs used for PUSCH 3-2 testing (Rel-13)	13.1.0
09-2015	RP-69	RP-151483	3155		Corrections to applicability of CSI requirements for low UE categories (Rel-13)	13.1.0
09-2015	RP-69	RP-151482	3164		CR for Rel-12 NAICS - Demodulation Test	13.1.0
09-2015	RP-69	RP-151482	3165		CR for Rel-12 NAICS - Fixed Reference Channels	13.1.0
09-2015	RP-69	RP-151482	3166		CR for Rel-12 NAICS - Interference Models	13.1.0
09-2015	RP-69	RP-151482	3167		CR for Rel-12 NAICS - CQI Tests	13.1.0
09-2015	RP-69	RP-151205	3168		Introduction of CA_7A-40A and CA_7A-40C to TS 36.101	13.1.0
09-2015	RP-69	RP-151593	3170		CR for Rel-13 NAICS – TM10 Demodulation and CSI Test	13.1.0
12-2015	RP-70	RP-152158	3172r1		Introduction of UE RF requirements for CA_42E	13.2.0
12-2015	RP-70	RP-152137	3173		Correction on UL 64QAM measurement channels	13.2.0

12-2015	RP-70	RP-152131	3175		Release 13 CAT A CR to align NS_04 values to meet FCC OOB requirements	13.2.0
12-2015	RP-70	RP-152136	3178		Maintenance of eIMTA PDSCH demodulation test	13.2.0
12-2015	RP-70	RP-152136	3180r1		Correction for eIMTA CQI tests	13.2.0
12-2015	RP-70	RP-152133	3186		Simplified CA fading Test method becomes optional	13.2.0
12-2015	RP-70	RP-152133	3191		Correction of the applicable UE categories for 256QAM UE demodulation performance requirements (Rel-13)	13.2.0
12-2015	RP-70	RP-152133	3193r1		Correction of TDD-FDD CA performance requirements (Rel-13)	13.2.0
12-2015	RP-70	RP-152133	3195r1		Correction on FDD CA and TDD CA performance requirements (Rel-13)	13.2.0
12-2015	RP-70	RP-152163	3196		CR on introduction of 5CC FDD/TDD CA demodulation performance requirements	13.2.0
12-2015	RP-70	RP-152163	3197		CR on introduction of 5CC TDD FDD CA demodulation performance requirements	13.2.0
12-2015	RP-70	RP-152132	3205		Correction of the AMPR table for NS_14 in TS 36.101 R13	13.2.0
12-2015	RP-70	RP-152134	3206		Correction of the 2UL CA co-existence table for CA_18A-28A	13.2.0
12-2015	RP-70	RP-152152	3209		Introduction of 3DL/2UL DC	13.2.0
12-2015	RP-70	RP-152139	3210r1		Correction of uplink configuration for CA_42D	13.2.0
12-2015	RP-70	RP-152133	3212		Introduction of dual uplink CA into 36.101	13.2.0
12-2015	RP-70	RP-152133	3214		Corrections to the CSI minimum requirement for PUSCH 3-2 (Rel-13)	13.2.0
12-2015	RP-70	RP-152133	3216		Corrections to MIMO Correlation Matrices using cross polarized antennas (Rel-12)	13.2.0
12-2015	RP-70	RP-152157	3221r1		Introducing B20 + B67 CA into TS 36.101	13.2.0
12-2015	RP-70	RP-152136	3225		CR for UE performance tests for intra-band contiguous CA with minimum channel spacing on Band 41	13.2.0
12-2015	RP-70	RP-152136	3227r1		Correction in SNR definition for CSI test	13.2.0
12-2015	RP-70	RP-152130	3232		Correction to reference channel for CQI requirements	13.2.0
12-2015	RP-70	RP-152168	3233r1		CR 36.101 BW combination for CA_8B	13.2.0
12-2015	RP-70	RP-152164	3241		Correction to mandatory 2UL support for 3DL interband CA	13.2.0
12-2015	RP-70	RP-152164	3242		Introduction of 2 UL and 3 DL interband cases with MSD	13.2.0
12-2015	RP-70	RP-152132	3246		CR on FRC for CDM-multiplexed DM RS	13.2.0
12-2015	RP-70	RP-152132	3249		Correction to physical channel for CQI reporting in type A test case	13.2.0
12-2015	RP-70	RP-152133	3255		CR for Rel-12 NAICS - Demodulation Test	13.2.0
12-2015	RP-70	RP-152133	3263		Correction on CA_4A-4A-5A table reference	13.2.0
12-2015	RP-70	RP-152134	3269r1		Clarification of Pcell support in 36.101 in CA scenarios	13.2.0
12-2015	RP-70	RP-152132	3273		A-MPR correction for CA_NS_06 CA-7C non-contiguous RB allocation	13.2.0
12-2015	RP-70	RP-152136	3276		Clarification on relative power tolerance for CA	13.2.0
12-2015	RP-70	RP-152133	3278		Correction of uplink configuration for CA_18-28	13.2.0
12-2015	RP-70	RP-152135	3280		CR on corrections for ProSe Direct Discovery demodulation requirements	13.2.0
12-2015	RP-70	RP-152135	3281		CR to finalize demodulation performance requirements for D2D Communication	13.2.0
12-2015	RP-70	RP-152131	3285		Missing RB allocation and OCNG Pattern for Cat 1 UEs in Multiple PMI CSI Reference Symbol tests	13.2.0
12-2015	RP-70	RP-152167	3286r1		Introduction of CA_5B to TS 36.101	13.2.0
12-2015	RP-70	RP-152169	3287		Introduction of CA_5A-5A to TS 36.101	13.2.0
12-2015	RP-70	RP-152133	3288		Introduction of dual uplink CA into 36.101	13.2.0
12-2015	RP-70	RP-152150	3291r1		CR on eD2D RF core requirements	13.2.0
12-2015	RP-70	RP-152171	3292r3		Introduction of B65 in Region 1	13.2.0
12-2015	RP-70	RP-152131	3294		Correction of supported sub-block frequency arrangement for CA_41-41	13.2.0
12-2015	RP-70	RP-152131	3296		Correction of test configuration for combinations of inter-band and intra-band CA	13.2.0
12-2015	RP-70	RP-152147	3299r2		RF receiver requirements for UE(s) supporting four antenna ports	13.2.0
12-2015	RP-70	RP-152148	3300r2		Introduction of RF requirements for LAA operation	13.2.0
12-2015	RP-70	RP-152172	3309r2		Introduction of Band 66	13.2.0
12-2015	RP-70	RP-152136	3311		Correction on CQI test 1A for TDD eIMTA	13.2.0

12-2015	RP-70	RP-152166	3312r 1			Introduction of 3DL/3UL Inter-band CA of CA_39A-41C and CA_39C-41A	13.2.0
12-2015	RP-70	RP-152133	3314			Correction of the resource allocation in FRC for CAT0 UE demodulation tests	13.2.0
12-2015	RP-70	RP-152151	3318			Introduce TM4 performance requirements when CRS assistance information is provided	13.2.0
12-2015	RP-70	RP-152151	3319r 1			Introduce TM10 performance requirements when CRS assistance information is provided for multiple-CSI-process capable UE	13.2.0
12-2015	RP-70	RP-152151	3320r 1			Introduce TM10 performance requirements when CRS assistance information is provided for one-CSI-process capable UE	13.2.0
12-2015	RP-70	RP-152163	3325			Introduction of 5DL/1UL CA combinations into TS 36.101	13.2.0
12-2015	RP-70	RP-152175	3326r 1			Introduction of Region 3 requirement in Band 65	13.2.0
12-2015	RP-70	RP-152138	3327			Correction of CA_8A-41C bandwidth combination set	13.2.0
12-2015	RP-70	RP-152133	3329			Removal of DC channel bandwidth combination set table	13.2.0
12-2015	RP-70	RP-152136	3331			CR on demodulation requirements of Dual Connectivity	13.2.0
12-2015	RP-70	RP-152131	3332r 1			Modification and correction of CA_3A-3A BCS1 in Rel.13 36.101	13.2.0
12-2015	RP-70	RP-152133	3334			Correction of MSD levels for 2UL inter-band CA in TS 36.101 Rel-13	13.2.0
12-2015	RP-70	RP-152162	3338			Introduction of finished 4DL inter-band CAs to TS 36.101	13.2.0
12-2015	RP-70	RP-152170	3339			Introduction of CA_7A-7A BCS1 to TS 36.101	13.2.0
12-2015	RP-70	RP-152164	3340r 1			Introduction of additional 2 UL and 3 DL interband cases with MSD	13.2.0
12-2015	RP-70	RP-152158	3341r 1			Addition of Class E into CA BW Class table.	13.2.0
12-2015	RP-70	RP-152131	3343			Table 6.2.4A-1 note 1 correction	13.2.0
12-2015	RP-70	RP-152164	3345			Removal of (NOTE 4) from Table 5.6A.1-2a	13.2.0
12-2015	RP-70	RP-152160	3347			Introduction of 4DL NC CA in band42 in 36.101	13.2.0
12-2015	RP-70	RP-152173	3348			Introduction of 1447-1467MHz Band into 36.101	13.2.0
12-2015	RP-70	RP-152136	3352			CR: PDSCH ETU600 performance requirements	13.2.0
12-2015	RP-70	RP-152156	3357			Introduction of additional band combinations for 2DL inter-band CA	13.2.0
12-2015	RP-70	RP-151972	3358r 2			Revision of the RAN4 approved R4-158446 (big CR 3DL 36.101)	13.2.0
12-2015	RP-70	RP-152147	3359r 1			Introduction of the Medium Correlation A model	13.2.0
12-2015	RP-70	RP-152147	3360r 1			Requirements for ePDCCH with 4Rx	13.2.0
12-2015	RP-70	RP-152147	3361r 1			Requirements for PDCCH with 4Rx	13.2.0
12-2015	RP-70	RP-152147	3362r 1			Requirements for PDSCH with 4Rx	13.2.0
12-2015	RP-70	RP-152147	3363r 1			Requirements for PHICH with 4Rx	13.2.0
12-2015	RP-70	RP-152159	3367r 1			Introduction of intra-band non-contiguous CA in Band 41 for 4DL	13.2.0
12-2015	RP-70	RP-152165	3368			Addition of 2 UL and 3 DL mixed intra/inter band carrier aggregation combinations without MSD.	13.2.0
12-2015	RP-70	RP-152133	3372r 1			Revision to CR 3256	13.2.0
12-2015	RP-70	RP-152133	3375			Correction to P <sub>max</sub> for CA to include delta_T_ProSe	13.2.0
12-2015	RP-70	RP-152162	3376			Delta TIB,c and Delta RIB,c for 1UL/4DL	13.2.0
12-2015	RP-70	RP-152136	3378			NS_05 modification for PHS protection in Japan	13.2.0
01-2016	RP-70					Editorial correction: Correction of reference to section 6.6.3.3.19 for NS_04 in Table 6.2.4-1	13.2.1
03/2016	RP-71	RP-160472	3467	1	B	UE receiver requirements for Rel-13 MTC	13.3.0
03/2016	RP-71	RP-160472	3443	1	B	CR on TX requirements for Rel-13 eMTC	13.3.0
03/2016	RP-71	RP-160474	3419		B	Introduce Robustness test for CRS-IM capable UE	13.3.0
03/2016	RP-71	RP-160474	3422	1	B	FRC for non-TM10 with CRS assistance information	13.3.0
03/2016	RP-71	RP-160474	3420	1	B	Introduce non-TM10 performance with CRS assistance information	13.3.0
03/2016	RP-71	RP-160474	3421	1	B	Introduce TM10 performance with CRS assistance information	13.3.0
03/2016	RP-71	RP-160474	3423	1	B	FRC for TM10 with CRS assistance information	13.3.0

03/2016	RP-71	RP-160475	3460	1	B	CR: Correction of FRC for SDR test (Rel-13)	13.3.0
03/2016	RP-71	RP-160479	3459		F	Correction of 4Rx demodulation performance requirements	13.3.0
03/2016	RP-71	RP-160479	3462		B	Correction of Correlation Model for Medium Correlation A	13.3.0
03/2016	RP-71	RP-160479	3466		B	UE Demodulation Requirements for DL Control channels for 4Rx	13.3.0
03/2016	RP-71	RP-160479	3463	1	B	UE Demodulation Requirements for DL PDSCH rank 1 and 2 performance	13.3.0
03/2016	RP-71	RP-160479	3464	1	B	UE Demodulation Requirements for DL PDSCH rank 3 and 4 requirements	13.3.0
03/2016	RP-71	RP-160479	3412	2	F	Corrections to UE RF receiver requirements for 4RX AP and support of CA	13.3.0
03/2016	RP-71	RP-160480	3431		B	Introduction of additional band combinations for 3DL inter-band CA	13.3.0
03/2016	RP-71	RP-160481	3396		B	Introduction of completed R13 4DL inter-band CA's to TS 36.101	13.3.0
03/2016	RP-71	RP-160482	3424		B	Introduction of 5DL/1UL CA combinations	13.3.0
03/2016	RP-71	RP-160483	3415	2	B	Introduction of Band 68 for Arab region into 36.101	13.3.0
03/2016	RP-71	RP-160487	3429		A	[Rel-13] Correction on Intra-band non-contiguous CA	13.3.0
03/2016	RP-71	RP-160488	3381		A	Correction to Type A CQI test parameters in TS 36.101	13.3.0
03/2016	RP-71	RP-160488	3405		A	CQI reports in CoMP fading test	13.3.0
03/2016	RP-71	RP-160488	3453		F	Maintenance CR for CA (Rel-13)	13.3.0
03/2016	RP-71	RP-160488	3461		A	Correction to TDD CQI Reporting for feICIC	13.3.0
03/2016	RP-71	RP-160488	3481		A	Beamforming model correction on TM10 DPS UE tests	13.3.0
03/2016	RP-71	RP-160489	3384		A	Correction in beam steering rate for 4 Tx antenna in Rel-13	13.3.0
03/2016	RP-71	RP-160489	3386		A	CR for correction to syncOffsetIndicator parameter in D2D resource pool configuration	13.3.0
03/2016	RP-71	RP-160489	3390		A	Correction of eIMTA CSI test	13.3.0
03/2016	RP-71	RP-160489	3402		A	[Rel-13] NS_05 modification for PHS protection in Japan	13.3.0
03/2016	RP-71	RP-160489	3411		A	Correction of P <sub>max</sub> for Dual Connectivity	13.3.0
03/2016	RP-71	RP-160489	3436		A	Correction on UE category in Annex of TS 36.101	13.3.0
03/2016	RP-71	RP-160489	3438		A	Removal of brackets for Maximum input level for 256QAM in TS 36.101	13.3.0
03/2016	RP-71	RP-160489	3440		A	Removal of brackets for Measurement channels for MTC in TS 36.101	13.3.0
03/2016	RP-71	RP-160489	3456		A	Maintenance CR for D2D (Rel-13)	13.3.0
03/2016	RP-71	RP-160489	3458		A	CR: Correction of FRC for SDR test (Rel-13)	13.3.0
03/2016	RP-71	RP-160489	3482		A	Maintenance CR for DC (Rel-13)	13.3.0
03/2016	RP-71	RP-160490	3382		F	Correction in UL CA support table	13.3.0
03/2016	RP-71	RP-160490	3397		F	Removing the brackets for 3+40 REFSSENS	13.3.0
03/2016	RP-71	RP-160490	3416		F	Corrections on BCS and EARFCN tables	13.3.0
03/2016	RP-71	RP-160490	3425		F	Removal of channel bandwidth sets for three bands DC	13.3.0
03/2016	RP-71	RP-160490	3427		F	Corrections to Notes in 2UL spurious emission table	13.3.0

03/2016	RP-71	RP-160490	3442		F	Revision of channel bandwidths for CA_B3_B41_B42 in 36.101	13.3.0
03/2016	RP-71	RP-160490	3447		F	Removing DC_5-17 from 36.101 Rel 13	13.3.0
03/2016	RP-71	RP-160490	3473		D	CR of editorial change on PHICH group and Ng in Rel-13	13.3.0
03/2016	RP-71	RP-160490	3477		F	Supported bandwidths for Band 66	13.3.0
03/2016	RP-71	RP-160490	3478		F	Corrections to CA_66C	13.3.0
03/2016	RP-71	RP-160490	3441	1	F	Correction on Annex D for LAA in TS 36.101	13.3.0
03/2016	RP-71	RP-160490	3406	3	F	Correction to UL 64 QAM measurement channels in TS 36.101	13.3.0
03/2016	RP-71	RP-160490	3430	3	F	Corrections and bracket removals to B46 specifications	13.3.0

06/2016	RP-72	RP-161141	3489		A	Correction on B39 coexistence spurious emission requirements	13.4.0
06/2016	RP-72	RP-161141	3491		A	Square brackets on B39 single carrier spurious emission requirements for protecting B3	13.4.0
06/2016	RP-72	RP-161135	3492		F	Introduction of EB/FD-MIMO channel model using 2D XP antennas at eNB	13.4.0
06/2016	RP-72	RP-161142	3493		F	CR to Correct Notes for CA REFSSENS Tables	13.4.0
06/2016	RP-72	RP-161142	3494		D	Editorial modification on uplink inter-band CA	13.4.0
06/2016	RP-72	RP-161141	3496		A	CSI requirements for 2DL FDD-TDD for UE Cat 3 (Rel 13)	13.4.0
06/2016	RP-72	RP-161141	3498		A	Wrong RMC description in overview table (Rel-13)	13.4.0
06/2016	RP-72	RP-161142	3499	1	F	Correction of P <sub>max</sub> for Prose	13.4.0
06/2016	RP-72	RP-161128	3504	3	B	Introduction of PDSCH demodulation requirement for Cat-M1 UE	13.4.0
06/2016	RP-72	RP-161128	3505	3	B	Introduction of CQI test for Cat-M1 UE	13.4.0
06/2016	RP-72	RP-161142	3507	1	C	Correcting fallback inconsistencies in CA of B41 and B42 in REL-13	13.4.0
06/2016	RP-72	RP-161141	3510	1	F	CR: Addition of performance requirement for TDD-FDD DC(Rel-13)	13.4.0
06/2016	RP-72	RP-161133	3514		F	Correction on 4Rx demodulation tests	13.4.0
06/2016	RP-72	RP-161142	3517		F	Introduction of 4Rx requirement for Band 1	13.4.0
06/2016	RP-72	RP-161142	3522		F	CR on reference measurement channel for Rel-13 eMTC	13.4.0
06/2016	RP-72	RP-161142	3526		F	Introduction of 4Rx REFSSENS for Band 41	13.4.0
06/2016	RP-72	RP-161142	3528		F	Rx requirement for the non-contiguous CA with more than two component carriers	13.4.0
06/2016	RP-72	RP-161141	3530		F	Correction on UE category for MTC and eMTC in TS 36.101	13.4.0
06/2016	RP-72	RP-161142	3531	1	F	Correction on eMTC in TS 36.101	13.4.0
06/2016	RP-72	RP-161140	3535		A	ACS for CA Bandwidth Class D: Case 2 wanted signal power	13.4.0
06/2016	RP-72	RP-161140	3538		A	Maintenance CR for demodulation performance requirements (Rel-13)	13.4.0
06/2016	RP-72	RP-161142	3545	1	F	Maintenance CR for CRS-IM	13.4.0
06/2016	RP-72	RP-161142	3548		F	Correction to UE Categories for 64 QAM Reference channels	13.4.0
06/2016	RP-72	RP-161142	3549		F	Clean up for CRS-IM related requirements	13.4.0
06/2016	RP-72	RP-161142	3551	2	F	Correction on eMTC In-band emissions in TS 36.101	13.4.0
06/2016	RP-72	RP-161136	3554	1	B	CR on the introduction of the LTE DL Control Channels Interference Mitigation: PDCCH/PCFICH demodulation performance requirements	13.4.0
06/2016	RP-72	RP-161136	3555	1	B	CR on the introduction of the LTE DL Control Channels Interference Mitigation: Interference models	13.4.0
06/2016	RP-72	RP-161141	3559		F	Corrections to 9.6.1.3 and 9.6.1.4 TDD FDD CQI Reporting test	13.4.0
06/2016	RP-72	RP-161142	3560		F	Corrections for CA_28A-42A and CA_28A-42C requirements	13.4.0
06/2016	RP-72	RP-161128	3568	1	B	CR for eMTC PBCH demodulation requirement for enhanced coverage	13.4.0
06/2016	RP-72	RP-161128	3569	1	B	CR for eMTC M-PDCCH demodulation requirement for CE Mode A and CE Mode B	13.4.0
06/2016	RP-72	RP-161135	3573		B	Introduction of EB/FD-MIMO Class A PMI test	13.4.0
06/2016	RP-72	RP-161135	3574		B	Introduction of EB/FD-MIMO Class B K=1 PMI test	13.4.0
06/2016	RP-72	RP-161142	3576		F	RMC for verification of RF receiver requirements for LAA	13.4.0
06/2016	RP-72	RP-161142	3578		F	Corrections of CA 8A-42A/C in REL-13	13.4.0
06/2016	RP-72	RP-161142	3579	1	F	CR on control channel requirements of 4 Rx UE	13.4.0
06/2016	RP-72	RP-161142	3585		F	CR on Frequency bands for UE category 0 and UE category M1	13.4.0
06/2016	RP-72	RP-161142	3587		F	CR for dTib,c and dRib,c for CA combinations including Band 21 and 42	13.4.0
06/2016	RP-72	RP-161126	3589		B	Category NB1 CR for 36.101	13.4.0
06/2016	RP-72	RP-161142	3590		F	CR for delta_F_HD for B46 combinations	13.4.0
06/2016	RP-72	RP-161136	3592	2	B	CR on Definitions for DL control channel IM	13.4.0
06/2016	RP-72	RP-161136	3593	1	B	CR on PHICH performance requirements for DL control channel IM	13.4.0
06/2016	RP-72	RP-161136	3594r1		B	CR on ePDCCH performance requirements for DL control channel IM	13.4.0
06/2016	RP-72	RP-161136	3595		B	CR on FRC for enhanced EPDCCH performance requirements	13.4.0
06/2016	RP-72	RP-161133	3597	1	B	Finalization of 4Rx UE Demodulation Requirements	13.4.0
06/2016	RP-72	RP-161142	3602	1	F	Clarification on eMTC RX requirements in TS 36.101	13.4.0
06/2016	RP-72	RP-161142	3610		F	Uplink configuration for reference sensitivity for B45	13.4.0
06/2016	RP-72	RP-161142	3614		F	CR: Maintenance CR for demodulation performance requirements (Rel-13)	13.4.0
06/2016	RP-72	RP-161142	3619		F	CR 36.101 on 7+38 blocking requirement	13.4.0
06/2016	RP-72	RP-161141	3623		A	Editorial correction for TM4 MMSE-IRC PDSCH demodulation test	13.4.0

06/2016	RP-72	RP-161142	3632	1	F	CR for TM9 tests with MBSFN subframes configured for PDSCH in Rel-13	13.4.0
06/2016	RP-72	RP-161133	3633	2	B	CR for applicability rule, antenna connection and test method for 4Rx UEs in Rel-13	13.4.0
06/2016	RP-72	RP-161136	3634	1	B	CR of introducing enhanced control channels requirements under asynchronous network in Rel-13	13.4.0
06/2016	RP-72	RP-161139	3635	1	F	Reference sensitivity for combinations of inter-band and NC intra-band CA	13.4.0
06/2016	RP-72	RP-161142	3636	1	F	Correction to A-MPR for NS_26	13.4.0
06/2016	RP-72	RP-161136	3640	1	B	CR for applicability rule for control channel enhancement requirements in Rel-13	13.4.0
2016/06	RP-72	RP-161164	3552	1	F	36.101 Section 5 operating bands (clean-up)	14.0.0
2016/06	RP-72	RP-161125	3553	-	B	Introduction of B70 to TS36.101	14.0.0
2016/06	RP-72	RP-161124	3577	1	B	Introduction of 2.6GHz SDL and CA B3_2.6SDL	14.0.0
2016/06	RP-72	RP-161123	3581	-	B	Introduction of additional 3DL/2UL CA band combinations in Rel-14	14.0.0
2016/06	RP-72	RP-161123	3582	-	B	Introduction of new 4DL/2UL CA band combination in Rel-14	14.0.0
2016/06	RP-72	RP-161119	3583	-	B	Introduction of additional band combinations for 4DL inter-band CA	14.0.0
2016/06	RP-72	RP-161116	3584	-	B	Introduction of additional band combinations for Intra-band CA	14.0.0
2016/06	RP-72	RP-161121	3588	-	B	Introduction of Rel-14 5DL inter-band combinations in 36.101	14.0.0
2016/06	RP-72	RP-161122	3603	-	B	Introduction of completed R14 2DL2UL band combinations to TS 36.101	14.0.0
2016/06	RP-72	RP-161118	3604	-	B	Introduction of completed R14 3DL band combination to TS 36.101	14.0.0
09/2016	RP-73	RP-161785	3645		A	Correct UE DL category for 256QAM demodulation	14.1.0
09/2016	RP-73	RP-161786	3647		A	CR on finalization of enhanced PDCCH/PCFICH performance requirements for DL control channel IM	14.1.0
09/2016	RP-73	RP-161611	3649		A	CR on introduction of OOC D2D Discovery demodulation requirements	14.1.0
09/2016	RP-73	RP-161632	3656		A	Improving the single antenna port description in UL-MIMO clauses	14.1.0
09/2016	RP-73	RP-161623	3657		B	Introduction of completed R14 3DL band combination to TS 36.101	14.1.0
09/2016	RP-73	RP-161635	3659		A	Correction of CA_42-42 sub-block CA configuration	14.1.0
09/2016	RP-73	RP-161784	3663		A	Correction of CA REFSENS harmonic formula	14.1.0
09/2016	RP-73	RP-161635	3665		A	Adding UL configuration for CA_28A-42A and CA_28A-42C	14.1.0
09/2016	RP-73	RP-161622	3667		B	Introduction of completed R14 2DL band combinations to TS 36.101	14.1.0
09/2016	RP-73	RP-161629	3672		A	CR: Update the power level setting for tests 8.3.1.2 and 8.3.2.3 (Rel-14)	14.1.0
09/2016	RP-73	RP-161782	3678		A	CR for eMTC M-PDCCH demodulation requirement for CE Mode B (Rel-14)	14.1.0
09/2016	RP-73	RP-161783	3684		A	CR for introducing LAA PDSCH demodulation performance requirements (Rel-13)	14.1.0
09/2016	RP-73	RP-161783	3686		A	CR for reference channel for LAA demodulation performance requirements (Rel-14)	14.1.0
09/2016	RP-73	RP-161780	3688		A	CR: NPDSCH Demodulation requirements and FRC definition for NB-IoT (Rel-14)	14.1.0
09/2016	RP-73	RP-161636	3690		A	Removal of brackets from category NB1 specification	14.1.0
09/2016	RP-73	RP-161636	3694		A	Editorial correction to category NB1 specifications	14.1.0
09/2016	RP-73	RP-161636	3696		A	Change of NB-IoT term into Category NB1	14.1.0
09/2016	RP-73	RP-161638	3698		A	Guard band requirements for Band 46 MSD	14.1.0
09/2016	RP-73	RP-161638	3699		F	Guard band requirements for Band 46 MSD	14.1.0
09/2016	RP-73	RP-161786	3701		A	Miscellaneous corrections of RF RX requirements for 4 RX AP	14.1.0
09/2016	RP-73	RP-161786	3703		A	Completion of the RF RX requirements for 4 RX AP	14.1.0
09/2016	RP-73	RP-161610	3705		A	Introduction of TM2/TM9 PDSCH demodulation requirements for eMTC	14.1.0
09/2016	RP-73	RP-161781	3707		A	Correction of eMTC PDSCH TM6 demodulation requirements	14.1.0
09/2016	RP-73	RP-161781	3709		A	Correction of eMTC CQI definition test	14.1.0
09/2016	RP-73	RP-161610	3711		A	Introduction of UE-selected subband CQI test for eMTC	14.1.0
09/2016	RP-73	RP-161609	3715		A	Downlink physical channel setup for NB-IoT UE demodulation requirements	14.1.0
09/2016	RP-73	RP-161636	3717		A	Corrections to channel bandwidth for category NB1 in TS36.101 (Rel-14)	14.1.0
09/2016	RP-73	RP-161614	3719		A	Introduce aperiodic CSI test for LAA	14.1.0
09/2016	RP-73	RP-161614	3721		A	Introduce signal model for LAA demodulation	14.1.0
09/2016	RP-73	RP-161614	3723		A	Introduce PDCCH test for LAA demodulation	14.1.0
09/2016	RP-73	RP-161786	3726		A	CR on finalization of enhanced PHICH performance requirements for DL control channel IM	14.1.0



09/2016	RP-73	RP-161786	3727		A	CR on finalization of enhanced ePDCCH performance requirements for DL control channel IM	14.1.0
09/2016	RP-73	RP-161624	3728		B	Introduction of additional band combinations for 4DL inter-band CA	14.1.0
09/2016	RP-73	RP-161621	3729		B	Introduction of additional band combinations for Intra-band CA	14.1.0
09/2016	RP-73	RP-161639	3732		A	Correction on in-band emission requirements for cat M1 UE	14.1.0
09/2016	RP-73	RP-161639	3734		A	Overview of UL reference measurement channels	14.1.0
09/2016	RP-73	RP-161634	3747		A	Removal of square brackets for Cat-0 REFSSENS configuration	14.1.0
09/2016	RP-73	RP-161638	3754		A	Corrections on TS36.101 for LAA	14.1.0
09/2016	RP-73	RP-161637	3756		A	Editorial modification on TS36.101 for NB-IoT	14.1.0
09/2016	RP-73	RP-161640	3758		A	Correction on operating bands for ProSe	14.1.0
09/2016	RP-73	RP-161638	3761		D	CR to add an informative column to UL Inter-band CA MSD tables	14.1.0
09/2016	RP-73	RP-161633	3765		A	CR for fixing power level for TM9 dual layer test in Rel-14	14.1.0
09/2016	RP-73	RP-161613	3767		A	CR for applicability rule, antenna connection and test method for 4Rx UEs in Rel-14	14.1.0
09/2016	RP-73	RP-161613	3769		A	CR for SDR tests with 4Rx in Rel-13	14.1.0
09/2016	RP-73	RP-161625	3772		B	Introduction of Rel-14 5DL inter-band combinations in 36.101	14.1.0
09/2016	RP-73	RP-161634	3776		A	2UL CA 5+17 correction	14.1.0
09/2016	RP-73	RP-161635	3778		A	Rel-13 CA corrections	14.1.0
09/2016	RP-73	RP-161613	3781		A	Corrections of UE requirements for 4Rx	14.1.0
09/2016	RP-73	RP-161613	3783		A	Finalizing UE CQI requirements for 4Rx	14.1.0
09/2016	RP-73	RP-161626	3786		B	Introduction of completed R14 2DL2UL band combinations to TS 36.101	14.1.0
09/2016	RP-73	RP-161636	3788		A	Clarification on EARFCN	14.1.0
09/2016	RP-73	RP-161636	3790		A	Corrections in 36.101 for NB-IoT UE	14.1.0
09/2016	RP-73	RP-161784	3794		A	Modification on E-UTRA Prose out of band blocking requirement	14.1.0
09/2016	RP-73	RP-161629	3799		A	Correction of OCNG	14.1.0
09/2016	RP-73	RP-161634	3806		A	Updated CA demodulation performance requirements (Rel-14)	14.1.0
09/2016	RP-73	RP-161640	3808		A	CR: Introduction of test requirements for new UE behaviour (Rel-14)	14.1.0
09/2016	RP-73	RP-161635	3810		A	CR: On eDC demodulation performance requirements	14.1.0
09/2016	RP-73	RP-161635	3812		A	Reference sensitivity exception for CA_20A-38A and CA_7A-20A-38A	14.1.0
09/2016	RP-73	RP-161629	3817		A	Missing CA reference sensitivity exceptions	14.1.0
09/2016	RP-73	RP-161634	3820		A	Correction on subframe pair definition for PCMAX of DC	14.1.0
09/2016	RP-73	RP-161629	3823		F	Missing CA reference sensitivity exceptions	14.1.0
09/2016	RP-73	RP-161629	3824		F	Correction of CR Implementation error to 36.101	14.1.0
09/2016	RP-73	RP-161611	3833		A	CR on eD2D demodulation performance requirements	14.1.0
09/2016	RP-73	RP-161615	3834		A	Introduction of EB/FD-MIMO PDSCH demodulation test	14.1.0
09/2016	RP-73	RP-161615	3835		A	Introduction of EB/FD-MIMO CRI Test	14.1.0
09/2016	RP-73	RP-161615	3836		A	Introduction of FRC for CRI test	14.1.0
09/2016	RP-73	RP-161615	3837		A	Introduction of performance requirements for FD-MIMO Class A and Class B K=1 PMI test cases	14.1.0
09/2016	RP-73	RP-161615	3843		A	CR: Correction of test parameters with Class B alternative codebook for one CSI-RS resource configured	14.1.0
09/2016	RP-73	RP-161615	3827		A	Introduction of EB/FD-MIMO MR functionality test	14.1.0
09/2016	RP-73	RP-161630	3830		A	Bracket removal for B3 and B39 UE co-existence	14.1.0
09/2016	RP-73	RP-161625	3650	1	F	Corrections of CA 1+41+42	14.1.0
09/2016	RP-73	RP-161635	3839		A	Corrections of 3+41+42	14.1.0
09/2016	RP-73	RP-161617	3840		B	Introduction of FRC for V2V in TS 36.101	14.1.0
09/2016	RP-73	RP-161638	3760	1	B	CR on UE RX requirements due to introduction of 10MHz CBW	14.1.0
09/2016	RP-73	RP-161629	3804	1	A	CR: Correction of power parameter for demodulation tests	14.1.0
09/2016	RP-73	RP-161624	3779	1	F	Rel-14 CA corrections	14.1.0
09/2016	RP-73	RP-161639	3668	1	A	Corrections on eMTC RX in TS 36.101	14.1.0
09/2016	RP-73	RP-161639	3845		A	Corrections for Rel-14 cat M1 UE	14.1.0
09/2016	RP-73	RP-161780	3832	1	A	CR on NPBCH Reference Measurement Channel for NB-IoT	14.1.0
09/2016	RP-73	RP-161637	3846		A	Corrections in 36.101 for NB-IoT UE	14.1.0
09/2016	RP-73	RP-161609	3713	1	A	Introduction of NPDCCH demodulation requirements	14.1.0
09/2016	RP-73	RP-161623	3773	2	B	Introduction of CA_2A-46A-46A, CA_4A-46A-46A and CA_46A-46A-66A	14.1.0
09/2016	RP-73	RP-161627	3741	1	B	Introduction of additional 3DL/2UL CA band combinations in Rel-14	14.1.0
09/2016	RP-73	RP-161627	3742	1	B	Introduction of new 4DL/2UL CA band combination in Rel-14	14.1.0
09/2016	RP-73	RP-161617	3730	2	B	Introduction of V2V Tx requirements in Rel-14	14.1.0
09/2016	RP-73	RP-161617	3740	3	B	Introduction of V2X Rx requirements to 36.101	14.1.0
09/2016	RP-73	RP-161782	3676	1	A	CR for eMTC M-PDCCH demodulation requirement for CE Mode A (Rel-14)	14.1.0

12/2016	RP-74	RP-162428	3868	2	F	Improvement of REFSENS requirement specification for band 46 CA combos	14.2.0
12/2016	RP-74	RP-162435	3876	1	A	Clarification on UE maximum output power	14.2.0
12/2016	RP-74	RP-162386	3879	1	A	CR: Updates to LAA PDSCCH demodulation performance requirements (Rel-14)	14.2.0
12/2016	RP-74	RP-162386	3881		A	CR: Updates to the reference channel for LAA demodulation performance requirements (Rel-14)	14.2.0
12/2016	RP-74	RP-162382	3885	1	A	CR for Rel-14 eMTC MPDCCH demodulation requirements	14.2.0
12/2016	RP-74	RP-162435	3887	2	A	CR for correction on OCNB pattern (Rel-14)	14.2.0
12/2016	RP-74	RP-162431	3891		A	RMC for maximum input level in category M1 UE	14.2.0
12/2016	RP-74	RP-162459	3901		A	CR for updating applicability rule for UE cat 9 UEs and DL Cat. 13 UEs in Rel-14	14.2.0
12/2016	RP-74	RP-162423	3903	2	A	CR for IRC TM2/3/3 tests with 4Rx in Rel-14	14.2.0
12/2016	RP-74	RP-162423	3905	1	A	CR for removing square brackets for 4Rx tests in Rel-14	14.2.0
12/2016	RP-74	RP-162394	3923	1	B	Introduction of REFSENS requirements for UL CA and 4RX AP	14.2.0
12/2016	RP-74	RP-162412	3927		A	UE to UE co-existence for B42 with 2ULs	14.2.0
12/2016	RP-74	RP-162382	3929	1	A	Correction of PDCSH demodulation requirements for eMTC	14.2.0
12/2016	RP-74	RP-162433	3943	2	B	Addition of new operating bands for NB-IoT	14.2.0
12/2016	RP-74	RP-162404	3946	3	F	Clarification of note6 for 3DL/2UL and 4DL/2UL CA	14.2.0
12/2016	RP-74	RP-162423	3948		A	CR for SDR CA tests with 4Rx for DL category 18 and 19	14.2.0
12/2016	RP-74	RP-162403	3949	1	F	Addition of missing source of IMD for 2UL-2DL CA	14.2.0
12/2016	RP-74	RP-162434	3952		A	Clarification on TX-RX frequency separation for Cat.NB1 (Rel-14)	14.2.0
12/2016	RP-74	RP-162423	3957	1	A	CR for fixing errors for 4Rx tests in Rel-14	14.2.0
12/2016	RP-74	RP-162408	3960	1	F	B70 TX RX Default Spacing	14.2.0
12/2016	RP-74	RP-162408	3961		F	B70 Carrier Frequency and EARFCN Correction	14.2.0
12/2016	RP-74	RP-162406	3965	1	B	Introduction of power class 2 HPUE in Band 41	14.2.0
12/2016	RP-74	RP-161989	3969	1	B	Addition of 1.4 and 3 MHz channel bandwidths for BAND 65 in TS36.101 (Rel-14)	14.2.0
12/2016	RP-74	RP-162423	3971	2	A	CR on 4-RX TM9 MU test	14.2.0
12/2016	RP-74	RP-162430	3978		A	Correction of power control for category M1	14.2.0
12/2016	RP-74	RP-162386	3981	1	A	Clean up and clarification for LAA CSI requirements	14.2.0
12/2016	RP-74	RP-162386	3983		A	Add PDCCH performance requirements for LAA demodulation	14.2.0
12/2016	RP-74	RP-162457	3986		B	Introduction of additional band combinations for 4DL inter-band CA	14.2.0
12/2016	RP-74	RP-162398	3987		B	Introduction of additional band combinations for Intra-band CA	14.2.0
12/2016	RP-74	RP-162415	3996		A	Correction to cell mapping for periodic CQI reporting on multiple cells	14.2.0
12/2016	RP-74	RP-162425	3999		A	Remove square brackets for FD-MIMO performance requirements	14.2.0
12/2016	RP-74	RP-162409	4000	1	F	Correction on FRC for V2V in TS 36.101	14.2.0
12/2016	RP-74	RP-162431	4002		A	CR for 36.101: frequency error for eMTC	14.2.0
12/2016	RP-74	RP-162403	4003		B	Introduction of completed R14 2DL2UL band combinations to TS 36.101	14.2.0
12/2016	RP-74	RP-162379	4005		A	CR: Updates to NPDCCH demodulation requirements for NB-IoT (Rel-14)	14.2.0
12/2016	RP-74	RP-162382	4009		A	CR for Rel-14 eMTC PBCH demodulation requirement for enhanced coverage	14.2.0
12/2016	RP-74	RP-162388	4010	1	B	CR for UE enhancement in SFN scenario	14.2.0
12/2016	RP-74	RP-162408	4012		A	CR: Corrections for bandwidth combination sets defined for inter-band DC (Rel-14)	14.2.0
12/2016	RP-74	RP-162411	4022		A	RMCs and applicability of core RF requirements	14.2.0
12/2016	RP-74	RP-162411	4031		A	Correction of spurious emissions requirements for Band 9 range and intra-band CA	14.2.0
12/2016	RP-74	RP-162408	4033		F	Correction to Band 70 reference to notes in 5.7.3	14.2.0
12/2016	RP-74	RP-162399	4037		B	Introduction of completed R14 2DL band combinations to TS 36.101	14.2.0
12/2016	RP-74	RP-162435	4040		A	Optional PCell indication	14.2.0
12/2016	RP-74	RP-162379	4042		A	Correction of NPDCCH demodulation requirements	14.2.0
12/2016	RP-74	RP-162382	4044		A	Finalizing CQI definition test for eMTC	14.2.0
12/2016	RP-74	RP-162384	4046	1	A	Finalizing UE-selected subband CQI test for eMTC	14.2.0
12/2016	RP-74	RP-162430	4048		A	Correction of REFSENS RMC table for Cat-M1 UE	14.2.0
12/2016	RP-74	RP-162400	4050		B	Introduction of completed R14 3DL band combinations to TS 36.101	14.2.0
12/2016	RP-74	RP-162404	4051		B	Introduction of additional 3DL/2UL CA band combinations in Rel-14	14.2.0
12/2016	RP-74	RP-162404	4052		B	Introduction of new 4DL/2UL CA band combination in Rel-14	14.2.0
12/2016	RP-74	RP-162404	4053		B	Introduction of new 5DL/2UL CA band combination in Rel-14	14.2.0
12/2016	RP-74	RP-162409	4054		F	CR for correction of V2X UE RF requirements	14.2.0
12/2016	RP-74	RP-162405	4057	1	B	UE CR for CBRS Band	14.2.0
12/2016	RP-74	RP-162433	4059		A	NB-IoT aggregate power control Rel-14	14.2.0

12/2016	RP-74	RP-162433	4061		A	Correction to NB-IoT ON/OFF power measurement period Rel-14	14.2.0
12/2016	RP-74	RP-162408	4065		A	Corrections to CA table reference and header and CA REFSSENS table	14.2.0
12/2016	RP-74	RP-162433	4068	1	A	A-MPR for NB-IoT	14.2.0
12/2016	RP-74	RP-162402	4074		B	Introduction of Rel-14 5DL inter-band combinations in 36.101	14.2.0
12/2016	RP-74	RP-162435	4078	1	F	Corrections of CA Refsens exceptions in 7.3.1A (Rel-14)	14.2.0
12/2016	RP-74	RP-162435	4081		A	DeltaRIB for SDL and LAA CA	14.2.0
12/2016	RP-74	RP-162388	4082	2	B	CR for introducing definition of Type-D receiver	14.2.0
12/2016	RP-74	RP-162459	4085	1	A	CR for fixing soft buffer management test for TDD-FDD CA in Rel-14	14.2.0
12/2016	RP-74	RP-162435	4087	1	A	CR for fixing editorial errors in Rel-14	14.2.0
12/2016	RP-74	RP-162394	4088	1	B	CR for introducing new demod tests for 4Rx CA	14.2.0
12/2016	RP-74	RP-162404	4091		A	Introduction of MSD requirement for IMD5 on band3 of CA_3A-8A 2UL CA	14.2.0
12/2016	RP-74	RP-162386	4093		A	CR: Updates to burst transmission model for LAA performance requirements (Rel-14)	14.2.0
12/2016	RP-74	RP-162430	4094		A	UE cat M1 out of band blocking, Removal of Range 4	14.2.0
12/2016	RP-74	RP-162406	4102	1	F	Versioning indicator bit for NS_04 A-MPR table	14.2.0
12/2016	RP-74	RP-162427	4104		A	Band 68 NS_26 A-MPR correction	14.2.0
12/2016	RP-74	RP-162406	4105		D	Addition of □PowerClass to list of symbols	14.2.0
12/2016	RP-74	RP-162420	4111		A	RF: Pb setting in power imbalance TCs (Rel-14)	14.2.0
12/2016	RP-74	RP-162420	4114		A	RF: Correction to RMC for UE Category 1 in CSI tests (Rel-14)	14.2.0
12/2016	RP-74	RP-162413	4118		A	RF: Beamforming model missing in chapter 9 TM9 receiver Type A tests (Rel-14)	14.2.0
12/2016	RP-74	RP-162459	4124		A	RF: Incorrect Number of EREGs per ECCE for special subframe mentioned for TC 8.7.4 (Rel-14)	14.2.0
12/2016	RP-74	RP-162428	4126	1	F	MSD and exclusion region specification for 10MHz LAA channels	14.2.0
12/2016	RP-74	RP-162392	4128	1	B	PC accuracy in SRS carrier based switching in UE core spec	14.2.0
12/2016	RP-74	RP-162387	4129		B	UL LBT core requirements in UE spec	14.2.0
12/2016	RP-74	RP-162431	4131		A	Missing requirements for eMTC/NB IoT UE	14.2.0
12/2016	RP-74	RP-162406	4135	1	F	Addition of TDD RMC for UL-DL configuration 0	14.2.0
12/2016	RP-74	RP-162380	4137	1	A	CR on NPBCH Fixed Reference Channel for NB-IoT	14.2.0
01/2017	RP-74					Page header information update	14.2.1
03/2017	RP-75	RP-170594	4139		A	Correction to carrier leakage and in-band emission for Cat. M1 UE	14.3.0
03/2017	RP-75	RP-170594	4141		A	Correction to Transmission Gap of Aggregate Power Control for Cat. M1 HD-FDD UE	14.3.0
03/2017	RP-75	RP-170566	4142	1	F	Corrections of Table 8.7.5.1-2 and Table 8.7.5.2-2	14.3.0
03/2017	RP-75	RP-170592	4144	1	B	Introduction of SDR test for LAA Scell	14.3.0
03/2017	RP-75	RP-170592	4146		A	Correction for LAA TM9 CQI test (R14)	14.3.0
03/2017	RP-75	RP-170562	4147		F	CR for rank 4 CA SDR tests	14.3.0
03/2017	RP-75	RP-170563	4148	1	B	CR for CQI test for Cat.1 UE with single Rx antenna	14.3.0
03/2017	RP-75	RP-170563	4149	1	B	CR for PDSCH demodulation test for Cat.1 UE with single Rx antenna	14.3.0
03/2017	RP-75	RP-170563	4150		B	CR for PHICH and PBCH demodulation test for Cat.1 UE with single Rx antenna	14.3.0
03/2017	RP-75	RP-170563	4151		B	CR for SDR test for Cat.1 UE with single Rx antenna	14.3.0
03/2017	RP-75	RP-170603	4153	1	A	Correction for FD-MIMO CRI test (R14)	14.3.0
03/2017	RP-75	RP-170577	4156		D	Split RMC overview table (R14)	14.3.0
03/2017	RP-75	RP-170587	4158		A	4Rx lot connections for 2Rx CQI requirement with frequency-selective interference	14.3.0
03/2017	RP-75	RP-170588	4163		A	Correction to UL/DL configuration & Special subframe configuration for CA CQI tests	14.3.0
03/2017	RP-75	RP-170597	4165		A	Remove [ ] from UE Cat M1 MPDCCH demodulation SNR values	14.3.0
03/2017	RP-75	RP-170576	4168	4	B	36.101 CR: Addition of Band 25 and Band 40 to M1 bands	14.3.0
03/2017	RP-75	RP-170575	4169		B	Release 14 CR to 36.101 to add Bands 25 and 26 to Category 0	14.3.0
03/2017	RP-75	RP-170563	4170	1	B	Introduction of Category 1bis requirements to 36.101	14.3.0
03/2017	RP-75	RP-170589	4172		A	Missing harmonic reference sensitivity exception for CA_20A-42A and CA_20A-42A-42A	14.3.0
03/2017	RP-75	RP-170589	4175		A	Correction to MPR table for intra-band 2UL CA	14.3.0
03/2017	RP-75	RP-170566	4176		F	Correction of notes on harmonic exception in 2DL CA 11A-28A	14.3.0
03/2017	RP-75	RP-170566	4177		F	Correction on uplink limitation of 2DL CA 8A-28A	14.3.0
03/2017	RP-75	RP-170570	4178		F	Correction of TIB and RIB on 2UL CA 41A-42A	14.3.0
03/2017	RP-75	RP-170568	4179		B	Introduction of additional band combinations for 4DL inter-band CA	14.3.0

03/2017	RP-75	RP-170565	4180		B	Introduction of additional band combinations for Intra-band CA	14.3.0
03/2017	RP-75	RP-170569	4181		B	Introduction of Rel-14 5DL inter-band combinations in 36.101	14.3.0
03/2017	RP-75	RP-170566	4182		F	Correction of Rel-14 CA configurations and relaxation values	14.3.0
03/2017	RP-75	RP-170566	4183	1	F	Correction of Rel-14 CA REFSENS exceptions	14.3.0
03/2017	RP-75	RP-170603	4185		A	Correction of Rel-13 CA REFSENS exceptions	14.3.0
03/2017	RP-75	RP-170553	4190	2	B	Introduction of UE requirements for LAA Scell uplink operation in Band 46	14.3.0
03/2017	RP-75	RP-170597	4192		A	Finalize eMTC PDSCH demodulation requirements	14.3.0
03/2017	RP-75	RP-170597	4194		A	Finalize eMTC CQI test requirements	14.3.0
03/2017	RP-75	RP-170594	4198		A	Correction of FRC table for eMTC RF test	14.3.0
03/2017	RP-75	RP-170590	4201		F	CR on correction of enhanced ePDCCH performance requirements for DL control channel IM	14.3.0
03/2017	RP-75	RP-170592	4204		A	Clean up and correction for LAA PDCCH demodulation requirements	14.3.0
03/2017	RP-75	RP-170599	4208	1	A	PCMAX tolerance for UE Cat NB1 power class 5	14.3.0
03/2017	RP-75	RP-170558	4209	1	B	Addition of uplink 256 QAM feature to TS 36.101	14.3.0
03/2017	RP-75	RP-170580	4213		A	Addition of missing note for bands 7 and 39 UE to UE co-ex	14.3.0
03/2017	RP-75	RP-170580	4217		A	Correction of CA_NS_06 non-contiguous resource allocation MPR formula	14.3.0
03/2017	RP-75	RP-170598	4218	1	A	Corrections in TS 36.101 for NB-IoT UE	14.3.0
03/2017	RP-75	RP-170592	4221	1	F	CR for LAA SDR applicability	14.3.0
03/2017	RP-75	RP-170592	4223	1	F	CR: Updates to LAA PDSCH demodulation performance requirements and LBT(R14)	14.3.0
03/2017	RP-75	RP-170598	4225		A	CR: Scheduling pattern for NPUSCH format 1 and NPDSCH in NB-IoT RF test(R14)	14.3.0
03/2017	RP-75	RP-170601	4227		A	CR: Updates to the overview of RMC for NB-IoT(R14)	14.3.0
03/2017	RP-75	RP-170601	4229		A	CR: Cleanup for NB-IoT UE demod performance requirements(R14)	14.3.0
03/2017	RP-75	RP-170585	4232		A	Corrections for D2D resource configuration (Rel-14)	14.3.0
03/2017	RP-75	RP-170555	4233	1	F	CR for UE enhancement in SFN scenario	14.3.0
03/2017	RP-75	RP-170595	4235		A	clean up the CR for eMTC PBCH requirements(Rel-14)	14.3.0
03/2017	RP-75	RP-170585	4243		A	CR for fixing requirement for soft buffer test for TDD-FDD CA in Rel-14	14.3.0
03/2017	RP-75	RP-170587	4245		A	CR for fixing power ratio errors in 4Rx tests in Rel-14	14.3.0
03/2017	RP-75	RP-170562	4246	1	B	CR for defining requirements for normal demodulation tests for 4Rx CA in Rel-14	14.3.0
03/2017	RP-75	RP-170562	4247	1	B	CR for introducing normal demodulation tests for 4Rx TDD-FDD CA in Rel-14	14.3.0
03/2017	RP-75	RP-170562	4249	1	B	CR for introducing applicability rule for normal demodulation tests	14.3.0
03/2017	RP-75	RP-170562	4251	1	B	CR for introducing new demodulation tests for 4Rx DC in Rel-14	14.3.0
03/2017	RP-75	RP-170587	4254		A	CR for correcting applicability rules for 4Rx tests in Rel-14	14.3.0
03/2017	RP-75	RP-170571	4256		B	Introduction of additional 3DL/2UL CA band combinations in Rel-14	14.3.0
03/2017	RP-75	RP-170571	4257		B	Introduction of new 4DL/2UL CA band combination in Rel-14	14.3.0
03/2017	RP-75	RP-170571	4258		B	Introduction of new 5DL/2UL CA band combination in Rel-14	14.3.0
03/2017	RP-75	RP-170559	4262	2	B	CR on intra-band contiguous MCC for V2X for TS 36.101	14.3.0
03/2017	RP-75	RP-170561	4263	2	B	Introduction of a new power class for NB-IoT	14.3.0
03/2017	RP-75	RP-170570	4264		B	Introduction of completed R14 2DL2UL band combinations to TS 36.101	14.3.0
03/2017	RP-75	RP-170567	4266		B	Introduction of completed R14 3DL band combinations to TS 36.101	14.3.0
03/2017	RP-75	RP-170574	4267	1	B	Introduction of bands to support 4Rx APs to TS 36.101	14.3.0
03/2017	RP-75	RP-170578	4268	1	F	CR for remaining issues for V2V UE RF requirements	14.3.0
03/2017	RP-75	RP-170559	4269		B	Introduction of inter-band con-current V2X UE RF requirements	14.3.0
03/2017	RP-75	RP-170559	4271	1	B	CR for Tx RF requirements for high power V2X	14.3.0
03/2017	RP-75	RP-170577	4274		F	Correction to Band 70 use on 20 MHz channel bandwidth	14.3.0
03/2017	RP-75	RP-170598	4279		A	CR for clarification on SEM of category NB1 [Rel-14]	14.3.0
03/2017	RP-75	RP-170594	4280		A	CR of TX-RX frequency separation for category M1 [Rel-14]	14.3.0
03/2017	RP-75	RP-170587	4282		A	CR for fixing antenna configuration for TDD CQI rank 3 test for 4Rx in Rel-13	14.3.0
03/2017	RP-75	RP-170594	4285		A	Reference Channels for partial RB allocation for UE UL category M1	14.3.0
03/2017	RP-75	RP-170566	4290		B	Introduction of completed R14 2DL band combinations to TS 36.101	14.3.0
03/2017	RP-75	RP-170559	4293		B	CR for single carrier V2X UE RF requirements	14.3.0
06/2017	RP-76	RP-171304	4299		A	Correction to 4Tx/4Rx Cell-specific reference signals in Table 8.10.1.1.7-1	14.4.0
06/2017	RP-76	RP-171269	4302	1	F	Introduction of Band 18 UE category 1bis into TS36.101	14.4.0

06/2017	RP-76	RP-171257	4304	1	F	eHST RF: Practical and consistent model definition for HST-SFN scenario (Rel-14)	14.4.0
06/2017	RP-76	RP-171308	4306		A	Correction to UL and DL Reference Channels for Cat M1 UE	14.4.0
06/2017	RP-76	RP-171296	4309		A	Corrections for D2D FRCs	14.4.0
06/2017	RP-76	RP-171279	4313	3	B	Introduction of new bands for NB-IoT in 36.101	14.4.0
06/2017	RP-76	RP-171269	4314	1	F	CR for correction for CQI test for Cat.1 UE with single Rx antenna	14.4.0
06/2017	RP-76	RP-171395	4318		A	Correction to SEM table for intra-band 2UL CA	14.4.0
06/2017	RP-76	RP-171310	4320		A	Cleanup of eMTC UE demodulation requirements (Rel-14)	14.4.0
06/2017	RP-76	RP-171311	4322	1	A	Correction for FD-MIMO demodulation test (R14)	14.4.0
06/2017	RP-76	RP-171278	4327	1	F	CR on correction for multiple MSD requirements for dual uplink CA UE	14.4.0
06/2017	RP-76	RP-171282	4329	1	F	CR on correction for V2X con-current operation	14.4.0
06/2017	RP-76	RP-171268	4332	1	B	CR for introducing requirements for normal demodulation tests for 4Rx CA in Rel-14	14.4.0
06/2017	RP-76	RP-171268	4333		B	CR for introducing for TDD-FDD DC normal demodulation tests for 4Rx CA in Rel-14	14.4.0
06/2017	RP-76	RP-171268	4334	1	B	CR for introducing new IRC tests for 4Rx CA in Rel-14	14.4.0
06/2017	RP-76	RP-171268	4336	1	F	CR for fixing errors of 4Rx CA in Rel-14	14.4.0
06/2017	RP-76	RP-171285	4339		F	CR for correction of eLAA UE RF requirements	14.4.0
06/2017	RP-76	RP-171307	4356	1	F	CR for LAA extension for PDSCH performance with multiple CCs in unlicensed bands	14.4.0
06/2017	RP-76	RP-171301	4358		A	Correction of NPDSCH and NPDCCH	14.4.0
06/2017	RP-76	RP-171304	4360		A	Maintenance CR for 4Rx WI (Rel-14)	14.4.0
06/2017	RP-76	RP-171310	4367		F	CR for PDSCH fixed reference channel (Rel-14)	14.4.0
06/2017	RP-76	RP-171304	4373		A	CR on 4-RX TM9 MU-MIMO performance requirements (Rel-14)	14.4.0
06/2017	RP-76	RP-171298	4375		A	CR on PDCCH/PCFICH DL Control Channel IM Type A TDD test case correction (Rel-14)	14.4.0
06/2017	RP-76	RP-171048	4379	1	B	Addition of Band 28 UE category 1bis into TS 36.101	14.4.0
06/2017	RP-76	RP-171282	4380	1	F	CR on applicability of V2X contiguous intraband multi-carrier operation requirements.	14.4.0
06/2017	RP-76	RP-171309	4383		A	Correction to Table A.4-1 and A.4-16 for CatM1.	14.4.0
06/2017	RP-76	RP-171310	4385		A	Correction to minimum requirement for CatM1 Single-Layer Spatial Multiplexing	14.4.0
06/2017	RP-76	RP-171300	4389		A	CR for demodulation of NB-IoT correction (Rel.14)	14.4.0
06/2017	RP-76	RP-171307	4391		A	CR for LAA TDD test case correction (Rel.14)	14.4.0
06/2017	RP-76	RP-171395	4397		F	Correction to the table of intra-band non-contiguous CA with one uplink configuration for reference sensitivity	14.4.0
06/2017	RP-76	RP-171263	4398	1	B	CR on performance requirements for MUST Case 1 and Case 2	14.4.0
06/2017	RP-76	RP-171263	4399	1	B	CR on performance requirements for MUST Case 3	14.4.0
06/2017	RP-76	RP-171263	4400		B	CR on Fixed Reference Channels for MUST	14.4.0
06/2017	RP-76	RP-171263	4401	1	B	CR on applicability rule for MUST Case 3	14.4.0
06/2017	RP-76	RP-171297	4405		A	Correction of N_RB_agg for CA_41C and CA_7C in Table 7.3.1A-1	14.4.0
06/2017	RP-76	RP-171296	4412		A	Correction to Mapping of CQI Index to Modulation coding scheme for 256QAM	14.4.0
06/2017	RP-76	RP-171304	4414		A	CR for correction of 4RX demodulation requirements (Rel-14)	14.4.0
06/2017	RP-76	RP-171278	4417		B	Introduction of new 3DL/2UL CA band combinations in rel-14	14.4.0
06/2017	RP-76	RP-171278	4418		B	Introduction of new 4DL/2UL CA band combination in Rel-14	14.4.0
06/2017	RP-76	RP-171290	4419	1	F	Correction on the additional SE for Band 41 UE in rel-14	14.4.0
06/2017	RP-76	RP-171282	4420	1	F	CR on V2X Pmax for non-concurrent operation	14.4.0
06/2017	RP-76	RP-171311	4424		A	Correction of test points for Single-antenna port performance TDD FDD CA	14.4.0
06/2017	RP-76	RP-171272	4425	1	B	Introduction of additional band combinations for Intra-band CA	14.4.0
06/2017	RP-76	RP-171275	4426	2	B	Introduction of Rel-14 4DL/1UL combinations in 36.101	14.4.0
06/2017	RP-76	RP-171282	4428		F	Clean ups of TS36.101 for V2X requirements	14.4.0
06/2017	RP-76	RP-171256	4432	1	B	CR for V2V Performance Requirements	14.4.0
06/2017	RP-76	RP-171261	4433		B	CR to 36.101: Introduction of FeMBMS numerologies	14.4.0
06/2017	RP-76	RP-171285	4435	1	F	Correction to A-MPR tables and in-band emissions for eLAA	14.4.0
06/2017	RP-76	RP-171304	4437		A	CR for FRC overview table for 4 layer SDR tests (R14)	14.4.0
06/2017	RP-76	RP-171269	4438		D	Maintenance CR for demodulation and CQI tests for Cat.1bis UE	14.4.0
06/2017	RP-76	RP-171307	4440	1	A	Maintenance CR for LAA demodulation tests	14.4.0
06/2017	RP-76	RP-171274	4441		F	Correction on uplink limitation of 3DL CA 8A-11A-28A	14.4.0
06/2017	RP-76	RP-171282	4442		F	Some corrections on V2X in TS 36.101	14.4.0
06/2017	RP-76	RP-171273	4443		B	Introduction of completed R14 2DL band combinations to TS 36.101	14.4.0
06/2017	RP-76	RP-171274	4444		B	Introduction of completed R14 3DL band combinations to TS 36.101	14.4.0

06/2017	RP-76	RP-171304	4446	1	F	4Rx REFSENS requirements spec improvement for 36.101	14.4.0
06/2017	RP-76	RP-171311	4448		A	CR for adding TDD 4 DL CA bandwidth combination for CQI CA tests in Rel-14	14.4.0
06/2017	RP-76	RP-171304	4450		A	CR for adding applicability rule for MU TM9 4Rx tests in Rel-14	14.4.0
06/2017	RP-76	RP-171268	4451	1	F	CR for updating applicability rule for SDR CA tests for 4Rx CA in Rel-14	14.4.0
06/2017	RP-76	RP-171268	4452	1	B	CR for further updating IRC tests for 4Rx CA in Rel-14	14.4.0
06/2017	RP-76	RP-171268	4453	1	B	CR for introducing applicability rule for 256QAM and higher layer tests for 4Rx CA	14.4.0
06/2017	RP-76	RP-171268	4454	1	B	CR for introducing 256QAM tests for 4Rx CA in Rel-14	14.4.0
06/2017	RP-76	RP-171268	4455	1	B	CR for introducing high layers tests for 4Rx CA in Rel-14	14.4.0
06/2017	RP-76	RP-171277	4457		F	Correction CR on 2UL CA for CA_2A-66A	14.4.0
06/2017	RP-76	RP-171277	4458		B	Introduction of completed R14 2DL2UL band combinations to TS 36.101	14.4.0
06/2017	RP-76	RP-171299	4460		F	Channel Raster For Multiple Standalone NB-IoT Carriers (TS 36.101)	14.4.0
06/2017	RP-76	RP-171276	4461		B	5DL UE CR	14.4.0
06/2017	RP-76	RP-171287	4462		B	CA bandwidth class Class B 256-QAM non-contiguous resource allocation MPR	14.4.0
06/2017	RP-76	RP-171280	4463		F	Corrections to CA configurations and bandwidth combination sets	14.4.0
06/2017	RP-76	RP-171300	4464		F	NB1/NB2 OOB note 3 correction	14.4.0
06/2017	RP-76	RP-171285	4465	1	F	Removing notes in two tables in UE spec wrt applicability of UL and DL requirements for band 46	14.4.0
06/2017	RP-76	RP-171311	4467		A	Correction on TDD-FDD CSI test cases (R14)	14.4.0
06/2017	RP-76	RP-171257	4468	1	F	Clean up the requirements for UE enhancement in SFN scenario	14.4.0
06/2017	RP-76	RP-171256	4469	1	B	CR for V2V FRCs	14.4.0
06/2017	RP-76	RP-171256	4470	1	B	CR for V2V resource pool configuration	14.4.0
06/2017	RP-76	RP-171297	4473		A	Corrections for inCoverage configuration in ProSe direct communication (Rel-14)	14.4.0
06/2017	RP-76	RP-171299	4475		A	CR for NB-IoT Absolute power tolerance	14.4.0
06/2017	RP-76	RP-171307	4477	1	B	Introduce LBT model for multite LAA Scell(s) in LAA demodulation	14.4.0
06/2017	RP-76	RP-171395	4482		F	Missing entries in list of intra-band CA bands	14.4.0
06/2017	RP-76	RP-171289	4483		F	Correction to NS_27 A-MPR table	14.4.0
06/2017	RP-76	RP-171307	4484	1	F	Update of LAA REFSENS exclusion region	14.4.0
06/2017	RP-76	RP-171266	4485	2	B	CR for CAT-M2 REFSENS, MPR and adding note for protection band 5	14.4.0
09/2017	RP-77	RP-171940	4487	1	F	Corrections on Rel-14 CA requirements	14.5.0
09/2017	RP-77	RP-171708	4490	1	F	CR for adding missing table for TDD 4 DL CQI CA tests in Rel-14	14.5.0
09/2017	RP-77	RP-171938	4495	1	F	CR for correcting TDD-FDD CA TM9 IRC tests for 4Rx CA in Rel-14	14.5.0
09/2017	RP-77	RP-171938	4497		F	CR for updating applicability rule of 4Rx CA in Rel-14	14.5.0
09/2017	RP-77	RP-171938	4498	2	F	CR for further updating IRC TM9 SINR requirements for 4Rx CA in Rel-14	14.5.0
09/2017	RP-77	RP-171938	4499	1	B	CR for introducing 256QAM SNR requirements for 4Rx CA in Rel-14	14.5.0
09/2017	RP-77	RP-171938	4500	1	B	CR for introducing 3 and 4 layers SNR requirements for 4Rx CA in Rel-14	14.5.0
09/2017	RP-77	RP-171932	4501	1	B	CR for introduction of PMCH and PDSCH demodulation tests for FeMBMS	14.5.0
09/2017	RP-77	RP-171941	4502		F	Corrections of Notes on REFSENS exception in 3DL/1UL of 1A-11A-28A and 3A-11-28A	14.5.0
09/2017	RP-77	RP-171941	4503		F	Modification of REFSENS exception in 4DL/1UL of 1A-3A-8A-11A	14.5.0
09/2017	RP-77	RP-171973	4505	1	F	Addition of OCNG Pattern for LAA Rx tests	14.5.0
09/2017	RP-77	RP-171940	4508	1	F	CR to 36.101 with corrections of newly introduced CA combinations	14.5.0
09/2017	RP-77	RP-171971	4510		A	PDSCH Demodulation downlink power allocation parameters for UEs supporting coverage enhancement. This CR was NOT implemented as it didn't use revision marks and the cover sheet information was wrong.	14.5.0
09/2017	RP-77	RP-171970	4514		A	Correction to Test Parameters for MPDCCH in Table 8.11.2.1-1	14.5.0
09/2017	RP-77	RP-171965	4515	2	A	Correction of band 43 spurious emissions limit (Rel-14)	14.5.0
09/2017	RP-77	RP-171942	4520		F	eHST RF: Further clarifications to HST-SFN scenario model (Rel-14)	14.5.0
09/2017	RP-77	RP-171941	4522	2	F	Correction to B26 Cat 0 REFSENS	14.5.0
09/2017	RP-77	RP-171939	4523	1	B	CR on Enhanced CRS-IM PDSCH performance requirements	14.5.0
09/2017	RP-77	RP-171939	4524		B	CR on Enhanced CRS-IM PDSCH FRCs	14.5.0

09/2017	RP-77	RP-171939	4525	2	B	CR on Enhanced CRS-IM PDCCH/PCFICH performance requirements	14.5.0
09/2017	RP-77	RP-171939	4526	1	B	CR on Enhanced CRS-IM PDSCH requirements applicability rules	14.5.0
09/2017	RP-77	RP-171939	4527	1	B	CR on Enhanced CRS-IM DL control channels requirements applicability rules	14.5.0
09/2017	RP-77	RP-171943	4532	1	F	Correction on the resource pool configuration for V2V demodulation tests	14.5.0
09/2017	RP-77	RP-171935	4533	1	B	CR for V2X resource pool configuration	14.5.0
09/2017	RP-77	RP-171941	4537	1	F	Minor corrections to B70 specifications	14.5.0
09/2017	RP-77	RP-171947	4539		A	Band 68 modification to enable operation in Europe	14.5.0
09/2017	RP-77	RP-171967	4544	1	A	Band 31 modification to add DTV protection Rel-14	14.5.0
09/2017	RP-77	RP-171940	4547	1	F	Corrections to Rel-14 CA configurations	14.5.0
09/2017	RP-77	RP-171970	4549		A	Correction to demodulation requirements for coverage enhancement UEs	14.5.0
09/2017	RP-77	RP-171972	4551	1	A	Correction to ON/OFF time mask for NB-IoT	14.5.0
09/2017	RP-77	RP-171970	4553		A	Correction of UE-selected subband CQI test for eMTC	14.5.0
09/2017	RP-77	RP-171970	4555		A	Correction of RMC for Cat-M1 TDD PDSCH demodulation requirements	14.5.0
09/2017	RP-77	RP-171969	4557	1	A	Addition of scheduling pattern with repetition for Cat-M1 UL FRC	14.5.0
09/2017	RP-77	RP-171969	4559		A	Correction of missing reference to Cat-M1 DL FRC tables	14.5.0
09/2017	RP-77	RP-171938	4560		B	CR for test applicability rule for 4 Rx CA tests	14.5.0
09/2017	RP-77	RP-171940	4561		F	CR for correcting FRC for Cat.1 bis demodulation test	14.5.0
09/2017	RP-77	RP-171940	4564		F	Correction CR on 5DL CA for CA_1A-3A-7A-26A	14.5.0
09/2017	RP-77	RP-171941	4566		F	4Rx spec correction CR for 36.101	14.5.0
09/2017	RP-77	RP-171942	4568		F	Maintenance of performance requirements for MUST	14.5.0
09/2017	RP-77	RP-171939	4569		B	CR for test applicability rule for enhanced SU-MIMO	14.5.0
09/2017	RP-77	RP-171935	4570	1	B	CR for V2X sidelink FRC	14.5.0
09/2017	RP-77	RP-171943	4572	1	F	Some corrections on V2X in TS 36.101	14.5.0
09/2017	RP-77	RP-171943	4578	1	F	CR on V2X duplexer mode in rel-14	14.5.0
09/2017	RP-77	RP-171942	4582	1	B	CR for CAT-M2 FRC	14.5.0
09/2017	RP-77	RP-171942	4583	1	F	CR for CAT-M2 REFSENS for FDD/TDD	14.5.0
09/2017	RP-77	RP-171943	4586	1	F	CR for V2V performance requirements (maintenance)	14.5.0
09/2017	RP-77	RP-171935	4587	1	B	CR for V2X test cases	14.5.0
09/2017	RP-77	RP-171939	4588	1	B	CR for enhanced SU-MIMO performance requirements	14.5.0
09/2017	RP-77	RP-171939	4589	1	B	CR for enhanced SU-MIMO FRCs	14.5.0
09/2017	RP-77	RP-171939	4590		B	CR for MIMO correlation matrices	14.5.0
09/2017	RP-77	RP-171964	4597		A	Correction for EPA delay profiles of r.m.s delay spread (Rel-14)	14.5.0
09/2017	RP-77	RP-171942	4599		F	Maintenance CR for channel model for HST-SFN scenario	14.5.0
09/2017	RP-77	RP-171942	4600		F	Maintenance CR for FRC for HST-SFN scenario	14.5.0
09/2017	RP-77	RP-171970	4602		A	CR for requirements of Cat-1bis and Cat-0(R14)	14.5.0
09/2017	RP-77	RP-171970	4604		A	CR for requirements of MPDCCH with 2Rx and 4Rx(R14)	14.5.0
09/2017	RP-77	RP-171970	4606		A	CR for requirements of TM2 with 2Rx and 4Rx(R14)	14.5.0
09/2017	RP-77	RP-171970	4610		A	CR for requirements of TM9 with 2Rx and 4Rx(R14)	14.5.0
09/2017	RP-77	RP-171970	4612		A	Correction to FRC Table A.3.4.2.1-7 for eMTC (R14)	14.5.0
09/2017	RP-77	RP-171937	4613	1	B	CR for NB-IoT enhancements	14.5.0
09/2017	RP-77	RP-171972	4615		A	CR for R13 NB-IoT performance requirements maintenances (R14)	14.5.0
09/2017	RP-77	RP-171938	4620		F	Addition of new Rel-14 CA 3DL CC test cases for 4Rx CA	14.5.0
09/2017	RP-77	RP-171938	4625		F	Addition of new Rel-14 CA 4DL CC test cases for 4Rx CA	14.5.0
09/2017	RP-77	RP-171938	4630		F	Addition of new Rel-14 CA 5DL CC test cases for 4Rx CA	14.5.0
09/2017	RP-77	RP-171965	4634		A	Apply CA demodulation performance requirements with 30us timing difference between two CCs to intra-band non-contiguous CA case	14.5.0
09/2017	RP-77	RP-171966	4639		A	Update to CA_NS_04 SEM and additional spurious emissions	14.5.0
09/2017	RP-77	RP-171969	4648		A	CR for Remove bracket for NS_07 in A-MPR requirement for CAT-M1	14.5.0
09/2017	RP-77	RP-171943	4649		F	CR on band definition for sidelink operation in band 47	14.5.0
09/2017	RP-77	RP-171955	4506	1	B	Introduction of Rel-15 LTE Intra-band combinations in 36.101	15.0.0
09/2017	RP-77	RP-171958	4507		B	Introduction of additional band combinations for 4DL CA	15.0.0
09/2017	RP-77	RP-171948	4536		B	Introduction of the FDD L-band (Band 74) into TS 36.101	15.0.0
09/2017	RP-77	RP-171946	4541	1	B	Introduction of Band 72 into TS 36.101	15.0.0
09/2017	RP-77	RP-171959	4545		B	5DL/1UL CR to TS 36.101	15.0.0
09/2017	RP-77	RP-171962	4565		B	Big CR for introduction new band support for 4Rx antenna ports R15 for LTE	15.0.0
09/2017	RP-77	RP-171957	4567		B	Introduction of completed R15 3DL band combinations to TS 36.101	15.0.0
09/2017	RP-77	RP-171956	4571	3	B	Introduction of completed combination to 36.101	15.0.0
09/2017	RP-77	RP-171960	4573	1	B	Introduction of completed R15 2DL/2UL band combinations to TS 36.101	15.0.0

09/2017	RP-77	RP-171951	4574		B	Introduction of power class 1 HPUE in Band 3, 20 and 28	15.0.0
09/2017	RP-77	RP-171961	4576		B	Introduction of additional 3DL/2UL CA band combinations w/o self-interference issues in Rel-15	15.0.0
09/2017	RP-77	RP-171961	4577	1	B	Introduction of additional 4DL/2UL CA band combinations w/o self-interference issues in Rel-15	15.0.0
09/2017	RP-77	RP-171963	4579		B	Addition of band 28 and 40 to LTE MTC Cat.0	15.0.0
09/2017	RP-77	RP-171953	4581		B	Introduction of V2X new band combinations in Rel-15	15.0.0
09/2017	RP-77	RP-171949	4598	1	B	Introduction of TDD L-band TS 36.101	15.0.0
09/2017	RP-77	RP-171952	4635	2	B	Introduction of Band 71 to 36.101	15.0.0
09/2017	RP-77	RP-171950	4640	1	B	Introduction of Extended 1.5 GHz SDL bands 75 and 76	15.0.0
09/2017	RP-77	RP-172047	4650		B	Additional LTE bands for UE category M1, NB1, M2, NB2 in Rel-15	15.0.0
12/2017	RP-78	RP-172574	4654		A	Correction to Test Parameters for Cat M1 PUCCH 1-0 static test	15.1.0
12/2017	RP-78	RP-172607	4657		A	Correction of the reference channel for the LAA CSI test	15.1.0
12/2017	RP-78	RP-172590	4658		B	Introduction of completed R15 2DL/2UL band combinations to TS 36.101	15.1.0
12/2017	RP-78	RP-172611	4661		A	CR for NB-IoT Transmit Intermodulation	15.1.0
12/2017	RP-78	RP-172610	4667	1	A	Corrections to NPDCCH configuration in NPDSCH test case	15.1.0
12/2017	RP-78	RP-172613	4676	1	A	Updates to performance requirements in 8.3.1.1 and 8.3.2.1A	15.1.0
12/2017	RP-78	RP-172584	4678		A	Maintenance CR for V2V (Rel-15)	15.1.0
12/2017	RP-78	RP-172585	4680		A	Maintenance CR for V2X (Rel-15)	15.1.0
12/2017	RP-78	RP-172582	4682		A	Maintenances CR for eSU-MIMO (Rel-15)	15.1.0
12/2017	RP-78	RP-172608	4685	1	A	CR for MPDCCH with 2Rx/4Rx (R15)	15.1.0
12/2017	RP-78	RP-172608	4688	1	A	CR for TM2/TM9 with 2Rx/4Rx (R15)	15.1.0
12/2017	RP-78	RP-172608	4691		A	CR on redundancy version for BL/CE UEs (R15)	15.1.0
12/2017	RP-78	RP-172586	4700		A	CR on reflection of FCC regulation for vehicle mounted UE at Band 30 in rel-15	15.1.0
12/2017	RP-78	RP-172608	4704		A	Applicability of CQI test for coverage enhancement for non-BL CE UE (Rel-15)	15.1.0
12/2017	RP-78	RP-172583	4706		A	Introduction of DL FRC for FeMTC RF test (Rel-15)	15.1.0
12/2017	RP-78	RP-172579	4708	1	A	Introduction of UE demodulation and CQI requirements for FeMTC (Rel-15)	15.1.0
12/2017	RP-78	RP-172584	4714		A	CR on correction of V2V Test requirement for power imbalance test	15.1.0
12/2017	RP-78	RP-172581	4717	1	A	CR for updating TDD CQI CA tests in Rel-15	15.1.0
12/2017	RP-78	RP-172582	4720	1	A	CR for updating overview table for 4Rx RMC in Rel-15	15.1.0
12/2017	RP-78	RP-172582	4722	1	A	CR for removing square bracket for 4Rx CA tests in Rel-15	15.1.0
12/2017	RP-78	RP-172593	4728		B	Introduction of Band 73 into TS 36.101	15.1.0
12/2017	RP-78	RP-172582	4732		A	Corrections to CA_29A-66C, CA_29A-70A and CA_29A-66A-66A	15.1.0
12/2017	RP-78	RP-172597	4733		F	Corrections to B29 CA related specifications	15.1.0
12/2017	RP-78	RP-172572	4734		B	ProSe support for Band 72	15.1.0
12/2017	RP-78	RP-172582	4737		A	Correction to supported bandwidths for CA configurations with Band 30	15.1.0
12/2017	RP-78	RP-172580	4740		A	NPDSCH demodulation test parameter and minimum requirement for CatNB2 UE Rel.15	15.1.0
12/2017	RP-78	RP-172581	4741		A	Correction of MPR for CA BW Class D	15.1.0
12/2017	RP-78	RP-172603	4744	1	F	Adding missing UE co-existence requirements for B71	15.1.0
12/2017	RP-78	RP-172596	4745		B	CR for 36101	15.1.0
12/2017	RP-78	RP-172586	4747		A	CR for EIRP based requirements in V2X	15.1.0
12/2017	RP-78	RP-172586	4749	1	A	CR for CEN DSRC and HDR DSRC coex requirement for V2X	15.1.0
12/2017	RP-78	RP-172573	4751		A	Draft CR for introduction of eFD-MIMO PMI test cases	15.1.0
12/2017	RP-78	RP-172573	4753		A	CR for introducing eFD-MIMO demodulation performance requirements	15.1.0
12/2017	RP-78	RP-172573	4755		A	Draft CR for introduction of eFD-MIMO Hybrid CSI test cases	15.1.0
12/2017	RP-78	RP-172573	4757		A	CR for introducing FRC for eFD-MIMO performance requirements test cases	15.1.0
12/2017	RP-78	RP-172612	4760	1	A	Correction CR for FD-MIMO performance requirements (R15 CAT A)	15.1.0
12/2017	RP-78	RP-172610	4763		A	Correction to NPDCCH configuration in demodulation test case	15.1.0
12/2017	RP-78	RP-172585	4765		A	CR on SNR values modification for V2X demodulation test cases (Rel-15)	15.1.0
12/2017	RP-78	RP-172583	4767		A	CR for introducing B1 Cat.M2 UE A-MPR in Japan into 36.101	15.1.0
12/2017	RP-78	RP-172595	4768		B	Introduction of additional band combinations for Intra-band CA	15.1.0
12/2017	RP-78	RP-172704	4769		B	Introduction of Rel-15 LTE 4DL/1UL combinations in 36.101	15.1.0
12/2017	RP-78	RP-172586	4772		A	Correction of channel spacing for band 46 intraband CA band combinations with 10 MHz bandwidth	15.1.0



12/2017	RP-78	RP-172598	4773		B	Introduction of 5DL CA combinations to 36.101	15.1.0
12/2017	RP-78	RP-172611	4777	1	A	NB-IoT removal of repetition sensitivity requirement Rel-15	15.1.0
12/2017	RP-78	RP-172601	4778		F	Correction to band 72	15.1.0
12/2017	RP-78	RP-172582	4780		F	Correction of CR Implementation error to 36.101 (REL-15)	15.1.0
12/2017	RP-78	RP-172594	4781	3	B	Introduction of Band 49	15.1.0
12/2017	RP-78	RP-172602	4782	2	F	CR to 36.101: corrections for HPUE requirements	15.1.0
12/2017	RP-78	RP-172585	4784	1	A	Correction on V2X resource pool configuration	15.1.0
12/2017	RP-78	RP-172587	4785	2	B	Add sTTI support to 6.3.4 ON/OFF Mask section	15.1.0
12/2017	RP-78	RP-172587	4786	2	B	Add sTTI support to sub-clauses related to Max output power, MPR, A-MPR and min output power of 36.101	15.1.0
12/2017	RP-78	RP-172587	4787	4	B	Add sTTI support to remaining sub-clauses of 36.101	15.1.0
12/2017	RP-78	RP-172612	4793		A	CSI 4RX: Correction to RI tests and used reference channels and MCS schemes (Rel-15)	15.1.0
12/2017	RP-78	RP-172607	4796		A	Correction of FRC for Cat-M1 UE maximum input level test (Rel-15)	15.1.0
12/2017	RP-78	RP-172581	4799		A	Corrections to FeMBMS demodulation test FRC rel.15	15.1.0
12/2017	RP-78	RP-172590	4802		B	Introduction of completed R15 2DL/2UL band combinations to TS 36.101	15.1.0
12/2017	RP-78	RP-172610	4804		A	CR for NB-IoT Additional Spectrum Emission Mask	15.1.0
12/2017	RP-78	RP-172606	4808	2	A	Corrections on operating band table for CA (Rel-15)	15.1.0
12/2017	RP-78	RP-172591	4810		B	Introduction of new xDL/2UL CA band combinations in Rel-15	15.1.0
12/2017	RP-78	RP-172581	4811	2	A	Corrections on inter-band CA operating bands (Rel-15)	15.1.0
12/2017	RP-78	RP-172612	4814	2	A	Corrections on the description of requirements for inter-band CA (Rel-15)	15.1.0
12/2017	RP-78	RP-172592	4815	1	B	Introduction of power class 2 HPUE in Band 38	15.1.0
12/2017	RP-78	RP-172582	4819		A	CR for further updating SDR 4Rx tests in Rel-15	15.1.0
12/2017	RP-78	RP-172597	4820		B	Introduction of completed R15 3DL band combinations to TS 36.101	15.1.0
12/2017	RP-78	RP-172598	4821		F	Correction to Uplink configurations for CA_5DL_1A-1A-3C-7A_1UL_BCS0, CA_5DL_1A-3C-7A-8A_1UL_BCS0 and max aggregation bandwidth for CA_1A-3C-7A-20A	15.1.0
12/2017	RP-78	RP-172585	4823		A	CR for updating overview table for V2X (Rel-15)	15.1.0
12/2017	RP-78	RP-172606	4827		A	CR for updating overview table for Sidelink (Rel-15)	15.1.0
12/2017	RP-78	RP-172584	4829		A	Corrections to UL 256QAM RMCs	15.1.0
12/2017	RP-78	RP-172612	4832		A	Addition of beamforming model to chapter 9 4Rx TM9 requirements	15.1.0
12/2017	RP-78	RP-172582	4837	2	A	Correction to Rel-15 CA configurations	15.1.0
12/2017	RP-78	RP-172581	4839	1	A	Correction to section 8.11.1.2.3	15.1.0
12/2017	RP-78	RP-172597	4840		F	Correction to Rel-15 CA configurations	15.1.0
12/2017	RP-78	RP-172587	4841	2	B	PCMAC for single carrier in Rel-15 sTTI operation	15.1.0
12/2017	RP-78	RP-172587	4842	2	B	PCMAC for UL CA in Rel-15 sTTI operation	15.1.0
12/2017	RP-78	RP-172581	4844		A	Addition of new 3DL CCs related test cases (Rel-15)	15.1.0
12/2017	RP-78	RP-172586	4851		A	CR on Uplink and sidelink configure for REFSENSE table	15.1.0
12/2017	RP-78	RP-172589	4852		B	Introduction of PC2 for CA_41C	15.1.0
12/2017	RP-78	RP-172605	4857		A	Update to A-MPR for CA_NS_04	15.1.0
12/2017	RP-78	RP-172586	4859		A	Correction of IMD Exclusion zone BW caused by dual uplink CA with band 46	15.1.0
12/2017	RP-78	RP-172549	4860		B	Introduction of missing 3DL fallbacks to 4DL combinations	15.1.0
2018-03	RAN#79	RP-180265	4862	1	B	CR on UE RF requirements for DL 1024QAM in TS 36.101	15.2.0
2018-03	RAN#79	RP-180296	4864		A	Update EVM requirements for V2X	15.2.0
2018-03	RAN#79	RP-180296	4866		A	CR on IBE requirements for intra-band contiguous multiple carriers	15.2.0
2018-03	RAN#79	RP-180266	4867	1	F	CR for TS 36.101: Removal UE requirements for shared spectrum channel access	15.2.0
2018-03	RAN#79	RP-180277	4868	1	B	Introduction of power class 2 HPUE in Band 40 and 42 to TS 36.101	15.2.0
2018-03	RAN#79	RP-180275	4870		B	Introduction of additional xDL/2UL CA band combinations in rel-15	15.2.0
2018-03	RAN#79	RP-180298	4872		A	Correction to Test Parameters for Cat M1 PUCCH 1-0 static test	15.2.0
2018-03	RAN#79	RP-180292	4875		A	Correction to UE-selected subband CQI test for eMTC	15.2.0
2018-03	RAN#79	RP-180296	4877		A	CR for removing square bracket for V2X eNB sync test (Rel-15)	15.2.0
2018-03	RAN#79	RP-180295	4879		A	Correction on FRC for 4Rx CA tests (Rel-15)	15.2.0
2018-03	RAN#79	RP-180292	4883		A	Maintennace CR for R13 Non-BL/UE requirements (R15)	15.2.0
2018-03	RAN#79	RP-180292	4885		A	PDSCH Demodulation downlink power allocation parameters for UEs supporting coverage enhancement	15.2.0
2018-03	RAN#79	RP-180295	4888		A	Correction to DL power allocation of CSI reporting for 4Rx UE in 9.9.4.1	15.2.0
2018-03	RAN#79	RP-180291	4891		A	Corrections to LAA CQI reporting requirements	15.2.0
2018-03	RAN#79	RP-180291	4894		A	Addition of two sided OCNG pattern for FS3	15.2.0
2018-03	RAN#79	RP-180276	4898		B	Introduction of UL CA_41C-42C into TS36.101	15.2.0
2018-03	RAN#79	RP-180297	4903		A	Correction of A-MPR table for UE Cat.M2 of Band 1	15.2.0

2018-03	RAN#79	RP-180294	4908		A	Correction on Test Parameters for FRC for CA more than 3DL CA	15.2.0
2018-03	RAN#79	RP-180272	4909		B	Introduction of completed R15 3DL/1UL band combinations to TS 36.101	15.2.0
2018-03	RAN#79	RP-180269	4910	2	B	CR on UE RF requirement for 8Rx	15.2.0
2018-03	RAN#79	RP-180270	4911		B	Introduction of additional band combinations for Intra-band CA	15.2.0
2018-03	RAN#79	RP-180273	4912		B	Introduction of Rel-15 LTE 4DL/1UL combinations in 36.101	15.2.0
2018-03	RAN#79	RP-180290	4921		A	Correction for CA CQI tests (R15)	15.2.0
2018-03	RAN#79	RP-180268	4922	2	B	CR for enhanced PDCCH demodulation performance for category 1bis UE with CRS-IM	15.2.0
2018-03	RAN#79	RP-180284	4923	1	F	Correction of a target band for FDD class 1 HP-UE	15.2.0
2018-03	RAN#79	RP-180294	4926	1	A	Corrections to Spurious emission band UE co-existence for CA	15.2.0
2018-03	RAN#79	RP-180295	4928		A	Correction CR for Semi-OL rank1 test (CAT A)	15.2.0
2018-03	RAN#79	RP-180279	4929	1	B	CR to 36.101: Introduction of Band 85 (B12-extended)	15.2.0
2018-03	RAN#79	RP-180285	4932		A	PC2 for CA_41C REL-15	15.2.0
2018-03	RAN#79	RP-180286	4933	1	F	Correction of band 72 MOP	15.2.0
2018-03	RAN#79	RP-180283	4936	1	F	Correction to UL-MIMO MOP Table Rel-15	15.2.0
2018-03	RAN#79	RP-180271	4937		F	MSD for CA_2A-71A	15.2.0
2018-03	RAN#79	RP-180271	4938	1	F	Introduction of CA band combination basis Delta TIB,c table	15.2.0
2018-03	RAN#79	RP-180271	4939	1	F	Introduction of CA band combination basis Delta RIB,c table	15.2.0
2018-03	RAN#79	RP-180298	4941		A	Clean up of PDSCH demodulation requirements for FeMTC	15.2.0
2018-03	RAN#79	RP-180290	4948		A	Adding note about timing difference for TDD CA (2Rx)	15.2.0
2018-03	RAN#79	RP-180299	4950		A	Adding note about timing difference for TDD CA and TDD FDD CA (4Rx)	15.2.0
2018-03	RAN#79	RP-180292	4953		A	CR to 36.101: Introduction of A-MPR table for NS4 and NS12 for CAT-M1	15.2.0
2018-03	RAN#79	RP-180294	4956		A	CSI 4RX: Correction to reference channels and MCS schemes used in RI tests (Rel-15)	15.2.0
2018-03	RAN#79	RP-180286	4957		F	Correction to Band 72 ProSe frequencies	15.2.0
2018-03	RAN#79	RP-180271	4959		B	CR for 36.101	15.2.0
2018-03	RAN#79	RP-180295	4961		A	CR on Enhanced CRS-IM test case applicability (Rel-15)	15.2.0
2018-03	RAN#79	RP-180299	4963		A	CR on definition of 4x1 MIMO correlation matrices (Rel-15)	15.2.0
2018-03	RAN#79	RP-180299	4965		A	CR to TS 36.101: Correction of CA table 7.3.1A-0bD R15	15.2.0
2018-03	RAN#79	RP-180299	4967		A	CR to TS 36.101: Correction of CA table 7.3.1A-6 R15	15.2.0
2018-03	RAN#79	RP-180278	4969	1	B	Introduction of TDD 3.3-3.4GHz band (band 52)	15.2.0
2018-03	RAN#79	RP-180274	4970		B	Introduction of 5DL CA combinations to 36.101	15.2.0
2018-03	RAN#79	RP-180292	4973		A	Correction of MPDCCH performance requirements	15.2.0
2018-06	RAN#80	RP-181086	4974	1	B	Enhanced PDCCH demodulation performance for category 1bis UE with CRS-IM TDD	15.3.0
2018-06	RAN#80	RP-181115	4980		A	CR on absolute power tolerance for V2X	15.3.0
2018-06	RAN#80	RP-181104	4982	1	F	CR on UE-to-UE coexistence requirements for LTE band 71	15.3.0
2018-06	RAN#80	RP-181092	4985		B	Introduction of 5DL CA combinations to 36.101 (This CR was superseded by CR#5096)	15.3.0
2018-06	RAN#80	RP-181100	4986	1	F	Corrections to B66+B70+B71 related Inter-band CA combinations	15.3.0
2018-06	RAN#80	RP-181097	4987		B	TS 36.101 big CR for introduction new band support for 4Rx antenna ports R15 for LTE	15.3.0
2018-06	RAN#80	RP-181108	4992		A	CA_NS_08 correction for TS 36.101 R15	15.3.0
2018-06	RAN#80	RP-181087	4993	1	B	CR for 36.101: 8Rx CA RF requirement	15.3.0
2018-06	RAN#80	RP-181086	4994	1	B	CR on 1RX CRS-IM PDSCH Cat1bis performance requirements	15.3.0
2018-06	RAN#80	RP-181086	4995	1	B	CR on 1RX CRS-IM PDSCH CatM2 performance requirements	15.3.0
2018-06	RAN#80	RP-181086	4996	1	B	CR on 1RX CRS-IM MPDCCH CatM2 performance requirements	15.3.0
2018-06	RAN#80	RP-181086	4997		B	CR on 1RX CRS-IM test case applicability	15.3.0
2018-06	RAN#80	RP-181078	4998	1	B	CR on FeCoMP UE PDSCH demodulation requirements	15.3.0
2018-06	RAN#80	RP-181114	5000		A	CR on Enhanced 4RX SU-MIMO test cases correction (Rel-15)	15.3.0
2018-06	RAN#80	RP-181112	5003		A	Clarification on TX-RX frequency separation for stand-alone NB-IoT operation	15.3.0
2018-06	RAN#80	RP-181114	5005	1	A	Addition of UL RMC for eLAA R15	15.3.0
2018-06	RAN#80	RP-181108	5009		A	Clarification of Transmission Modes for REFSEN test R15	15.3.0
2018-06	RAN#80	RP-181108	5013		A	Correction for CA CQI tests (R15)	15.3.0
2018-06	RAN#80	RP-181105	5021		F	Cat.F CR for UE-to-UE co-existence for Band 3 in Japan (Rel-15)	15.3.0
2018-06	RAN#80	RP-181077	5025	1	F	Clarification on sTTI applicability and wording fixes	15.3.0
2018-06	RAN#80	RP-181098	5026		F	CR to 36.101: Removed note for B42 PC2 from UE power class Table	15.3.0
2018-06	RAN#80	RP-181115	5028		A	Correction to RMC for UL 256QAM	15.3.0
2018-06	RAN#80	RP-181111	5031		A	Update to eMTC demod requirements	15.3.0

2018-06	RAN#80	RP-181091	5035		B	Introduction of Rel-15 LTE 4DL/1UL combinations in 36.101 (This CR was superseded by CR#5098)	15.3.0
2018-06	RAN#80	RP-181103	5036		F	Correction of UE co-existence from bands 12/17 into band 51	15.3.0
2018-06	RAN#80	RP-181111	5039		A	Correction of UE co-existence from band 28 into band 66	15.3.0
2018-06	RAN#80	RP-181111	5041		A	Correction of UE co-existence from band 28 into band 66 (CA part 1)	15.3.0
2018-06	RAN#80	RP-181111	5042		F	Correction of UE co-existence from band 28 into band 66 (CA part 2)	15.3.0
2018-06	RAN#80	RP-181093	5043		B	Introduction of more than 5DL CA combinations to 36.101	15.3.0
2018-06	RAN#80	RP-181081	5044	2	B	CR ON_OFF mask for feLAA	15.3.0
2018-06	RAN#80	RP-181083	5045	1	B	MPR for PC6 CAT-M1 and CAT-M2	15.3.0
2018-06	RAN#80	RP-181106	5051		A	CR: Corrections for CSI tests (Rel-15)	15.3.0
2018-06	RAN#80	RP-181108	5054		A	Correction to uplink configuration for CA_25A-41C	15.3.0
2018-06	RAN#80	RP-181089	5055		B	CR to add new 2DL1UL CA combos to 36101	15.3.0
2018-06	RAN#80	RP-181090	5056		B	Introduction of Rel-15 LTE 3DL/1UL combinations in 36.101 (This CR was superseded by CR#5109)	15.3.0
2018-06	RAN#80	RP-181100	5057		F	Improvement of REFSENS exceptions due to harmonic issue	15.3.0
2018-06	RAN#80	RP-181095	5058		B	Introduction of 3UL CA into TS36.101	15.3.0
2018-06	RAN#80	RP-181100	5059		F	Improvement of REFSENS exceptions for due to close proximity of UL to DL channel	15.3.0
2018-06	RAN#80	RP-181100	5060		F	Improvement of REFSENS exceptions due to harmonic issues in mixed intra and inter-band CA	15.3.0
2018-06	RAN#80	RP-181100	5061		F	Improvement of REFSENS exceptions due to cross band isolation issues	15.3.0
2018-06	RAN#80	RP-181113	5064		A	Correction to DL power allocation of CSI reporting for 4Rx UE in 9.9.4.2	15.3.0
2018-06	RAN#80	RP-181110	5067		A	Correction to CQI reporting definition on PUSCH static test	15.3.0
2018-06	RAN#80	RP-181094	5070		F	CR to add note 19 to CA_26A-41A and CA_5A-41A in harmonic table	15.3.0
2018-06	RAN#80	RP-181078	5072	1	B	CR on FeCoMP UE CSI reporting requirements	15.3.0
2018-06	RAN#80	RP-181089	5073	1	F	CR to correct Note 18 in table 7.3.1A-0bE in rel 15	15.3.0
2018-06	RAN#80	RP-181089	5074	1	B	CR for 36101 to update 2DL1UL CA basket items	15.3.0
2018-06	RAN#80	RP-181116	5077		A	Correction to Rel-14 CA configurations	15.3.0
2018-06	RAN#80	RP-181100	5078		F	Addition of Band 72 and 73 to chapter 8 and 9 general clauses	15.3.0
2018-06	RAN#80	RP-181110	5081		A	Correction to LAA RMC (Rel-14)	15.3.0
2018-06	RAN#80	RP-181110	5084		A	Update to chapter 8 LAA requirements	15.3.0
2018-06	RAN#80	RP-181091	5085		F	Corrections to Rel-15 CA configurations	15.3.0
2018-06	RAN#80	RP-181094	5086		B	Introduction of additional xDL/2UL CA band combinations in rel-15	15.3.0
2018-06	RAN#80	RP-181096	5087		B	CR on introduction of new V2X band combinations in rel-15	15.3.0
2018-06	RAN#80	RP-181084	5088	2	B	NB-IoT: Adding TDD support in TS 36.101	15.3.0
2018-06	RAN#80	RP-181115	5091		A	Removal of square brackets from eNB-IoT UE demodulation requirements	15.3.0
2018-06	RAN#80	RP-181093	5092		B	Introduction of more than 5DL CA combinations to 36.101	15.3.0
2018-06	RAN#80	RP-181111	5095		A	Correction to eMTC subband CQI test R15	15.3.0
2018-06	RAN#80	RP-181092	5096		B	Introduction of 5DL CA combinations to 36.101	15.3.0
2018-06	RAN#80	RP-181091	5098		B	Introduction of Rel-15 LTE 4DL/1UL combinations in 36.101	15.3.0
2018-06	RAN#80	RP-181104	5099	1	F	Adding missing spurious emission UE co-existence requirement for B70	15.3.0
2018-06	RAN#80	RP-181079	5102	1	B	CR on introduction of Tx Diversity scenario for eV2X in TS 36.101	15.3.0
2018-06	RAN#80	RP-181079	5103		B	CR on introduction of sidelink 64QAM in TS 36.101	15.3.0
2018-06	RAN#80	RP-181079	5104		B	CR on introduction of new eV2X scenarios in TS 36.101	15.3.0
2018-06	RAN#80	RP-181116	5107		A	CR to add nominal guard band for CA bandwidth class F	15.3.0
2018-06	RAN#80	RP-181083	5108	1	B	CR_UE_RF requirement on subPRB feature	15.3.0
2018-06	RAN#80	RP-181090	5109		B	Introduction of completed R15 3DL/1UL band combinations to TS 36.101	15.3.0
2018-06	RAN#80	RP-181107	5114		A	Update to CA_NS_04 requirements	15.3.0
2018-06	RAN#80	RP-181108	5118		A	Update to NS_04 requirements	15.3.0
2018-06	RAN#80	RP-181116	5120		A	Update to NS_27 requirements	15.3.0
2018-06	RAN#80	RP-181092	5124		F	Missing channel bandwidths and editorial corrections	15.3.0
2018-06	RAN#80	RP-181101	5125	2	B	Introduction of power class 1 HPUE in Band 31 and 72	15.3.0
2018-06	RAN#80	RP-181100	5128	2	F	CR on Correction on Band 74 requirement on protecting EESS	15.3.0
2018-06	RAN#80	RP-181088	5129		B	Introduction of Rel-15 LTE Intra-band combinations in 36.101	15.3.0
2018-06	RAN#80	RP-181115	5130		A	CR on A-SE, A-SEM and A-MPR for V2X Service in Band 47	15.3.0
2018-09	RAN#81	RP-181899	5169	1	B	CR_UE_RF requirement on low output power	15.4.0
2018-09	RAN#81	RP-181899	5170	1	B	CR_UE_RF requirement on subPRB feature	15.4.0
2018-09	RAN#81	RP-181902	5164		F	CR on UE category for DL 1024QAM in TS 36.101	15.4.0

2018-09	RAN#81	RP-181902	5141	2	B	CR: test case for reduced DMRS	15.4.0
2018-09	RAN#81	RP-181903	5167		F	CR on V2X reference measurement channel for R15	15.4.0
2018-09	RAN#81	RP-181908	5190	1	A	Correction on Table 7.3.1-3 Network signalling value for reference sensitivity	15.4.0
2018-09	RAN#81	RP-181909	5159		A	Mirror CR Rel-15 towards TS 36.101 to remove square brackets for CA_4A-7A_12A	15.4.0
2018-09	RAN#81	RP-181909	5150	1	F	Correction on Table 6.6.3.2A-0 Requirements for uplink inter-band carrier aggregation (two bands)	15.4.0
2018-09	RAN#81	RP-181912	5135		A	Correction of cqi-pmi-ConfigurationIndex for PUCCH 1-0 static test on multiple cells	15.4.0
2018-09	RAN#81	RP-181913	5179		A	Corrections of Rel-15 CA specs	15.4.0
2018-09	RAN#81	RP-181913	5173	1	A	CR to add CA_1-21-42 in exception table	15.4.0
2018-09	RAN#81	RP-181913	5163	1	A	CR correction of UL CA configuration CA_40D REFSSENS requirement Rel-15	15.4.0
2018-09	RAN#81	RP-181914	5138		A	CR on A-SE, A-SEM and A-MPR for V2X Service in Band 47	15.4.0
2018-09	RAN#81	RP-181914	5193		A	CR on frame structure type for band 47	15.4.0
2018-09	RAN#81	RP-181914	5168	1	A	CR on V2X reference measurement channel for 64QAM	15.4.0
2018-09	RAN#81	RP-181916	5132		A	Correction on the typo in subclause 9.11.1	15.4.0
2018-09	RAN#81	RP-181916	5152	1	A	Correction on Table 7.3.1A-0bE	15.4.0
2018-09	RAN#81	RP-181916	5154	1	F	Correction on Table 7.3.1A-5	15.4.0
2018-09	RAN#81	RP-181916	5160	1	A	Rel-15 CR towards TS 36.101 to correct errors in notes	15.4.0
2018-09	RAN#81	RP-181917	5139		F	CR on 1RX CRS-IM requirements corrections	15.4.0
2018-09	RAN#81	RP-181917	5140		F	CR on FeCoMP requirements corrections	15.4.0
2018-09	RAN#81	RP-181917	5177		F	Corrections of REFSSENS exceptions	15.4.0
2018-09	RAN#81	RP-181917	5181		F	Corrections to Rel-15 CA configurations	15.4.0
2018-09	RAN#81	RP-181917	5176	1	F	Corrections of Rel-15 CA specs	15.4.0
2018-09	RAN#81	RP-181917	5183	1	B	Introduction of missing R15 2DL2UL band combinations to TS 36.101	15.4.0
2018-09	RAN#81	RP-181917	5146	1	F	Correction on Table 6.6.3.2-1 Spurious emission band UE co-existence	15.4.0
2018-12	RAN#82	RP-182383	5196		F	UE category M1 and M2 MPR section corrections Rel-15	15.5.0
2018-12	RAN#82	RP-182388	5199		F	Simplification of CA UE to UE co-ex table by adopting CA band approach	15.5.0
2018-12	RAN#82	RP-182385	5204		A	Correction to PDSCCH CA and DC Demodulation (4 Rx Ant ports)	15.5.0
2018-12	RAN#82	RP-182369	5206	1	B	CR for eV2X FRCs and resource pool configuration	15.5.0
2018-12	RAN#82	RP-182369	5207		F	CR on RMC for sidelink 64QAM	15.5.0
2018-12	RAN#82	RP-182388	5210		F	Correction of BCS for CA_3A-3A-7A-20A and CA_2A-46A-48C-66A	15.5.0
2018-12	RAN#82	RP-182364	5214	3	B	Introduction of Slot/Subslot-PDSCCH demodulation requirements	15.5.0
2018-12	RAN#82	RP-182364	5215	3	B	Introduction of SPDCCCH demodulation requirements	15.5.0
2018-12	RAN#82	RP-182364	5216	3	B	Introduction of CQI tests for sTTI	15.5.0
2018-12	RAN#82	RP-182365	5217	3	B	Introduction of UE demodulation requirements for eFeMTC	15.5.0
2018-12	RAN#82	RP-182365	5218	2	B	Introduction of CQI reporting requirements for eFeMTC	15.5.0
2018-12	RAN#82	RP-182381	5225	1	A	Correction of spurious emission band UE co-existence for NB-IoT	15.5.0
2018-12	RAN#82	RP-182374	5227	2	B	CR on introduction of 6CCs and 7CCs FDD/TDD CA demodulation performance requirements	15.5.0
2018-12	RAN#82	RP-182374	5228	2	B	CR on introduction of 6CCs and 7CCs FDD-TDD CA demodulation performance requirements	15.5.0
2018-12	RAN#82	RP-182374	5229	2	B	CR on introduction of 6CCs and 7CCs SDR test cases requirements	15.5.0
2018-12	RAN#82	RP-182383	5232		A	Clarification of applicability for demodulation requirement for CE UE R15	15.5.0
2018-12	RAN#82	RP-182368	5233		F	Clarification of applicability rule and test parameter for OCC4-based TM9 rank4 demodulation requirement R15	15.5.0
2018-12	RAN#82	RP-182388	5234	1	F	Correction to test parameter in 1Rx CRS-IM demodulation requirement	15.5.0
2018-12	RAN#82	RP-182382	5239	1	F	Correction of LTE UE requirements for inter-band CA - R15	15.5.0
2018-12	RAN#82	RP-182373	5244		B	CR: Addition of propagation conditions related with 8Rx	15.5.0
2018-12	RAN#82	RP-182368	5245	3	B	CR:For 1024QAM DL demodulation requirements under fading propagation conditions	15.5.0
2018-12	RAN#82	RP-182385	5252		F	Updating the limit of the Power Spectral Density for LAA in Korea	15.5.0
2018-12	RAN#82	RP-182385	5257	1	F	Correction on REFSSENS exception of CA_3A-28A-42C for REL-15	15.5.0
2018-12	RAN#82	RP-182379	5261	1	A	Correction to frequency of CA_4A-7A for MSD with inter-band 2UL	15.5.0
2018-12	RAN#82	RP-182362	5263	1	B	Introduction of NR band protection in TS36.101	15.5.0
2018-12	RAN#82	RP-182369	5264		B	CR on eV2X UE soft buffer and SDR requirements	15.5.0
2018-12	RAN#82	RP-182386	5265	1	B	CR to TS 36.101: Implementation of UL PRB to DL PRB center offset for TDD NB-IoT	15.5.0

2018-12	RAN#82	RP-182369	5266	1	B	CR for eV2X single link PSSCH tests and PSCCH decoding capability test cases	15.5.0
2018-12	RAN#82	RP-182381	5273		A	PDSCH traffic pattern in 4Rx PHICH Demodulation test - Rel-15	15.5.0
2018-12	RAN#82	RP-182379	5275	1	A	MCG/SCG Abbreviations in TS36.101 in rel-15	15.5.0
2018-12	RAN#82	RP-182385	5280		A	Remove the brackets in Rel-14 V2V AMPR	15.5.0
2018-12	RAN#82	RP-182385	5285		A	Corrections of REFSSENS exceptions in Rel-15 Cas	15.5.0
2018-12	RAN#82	RP-182388	5286	1	F	Misc corrections on Rel-15 CAs	15.5.0
2018-12	RAN#82	RP-182366	5291	1	A	CR MPR for NB-IoT PC6 Rel-15	15.5.0
2018-12	RAN#82	RP-182374	5293		B	CR on introduction of 6CCs and 7CCs LAA CA demodulation performance requirements	15.5.0
2018-12	RAN#82	RP-182365	5298	1	B	CR_UE RF requirement on subPRB feature_cat_M1	15.5.0
2018-12	RAN#82	RP-182365	5299		B	CR_UE RF requirement on subPRB feature_cat_M2	15.5.0
2018-12	RAN#82	RP-182388	5301		F	Rel-15 CR to remove NS_04 requirements	15.5.0
2018-12	RAN#82	RP-182373	5303	1	B	CR on 8Rx CA RF requirement for TS 36.101	15.5.0
2018-12	RAN#82	RP-182372	5306	1	B	CR for demodulation performance requirements for network-based CRS interference mitigation	15.5.0
2018-12	RAN#82	RP-182373	5307	1	B	CR: applicability and test rules for 8Rx capable UEs	15.5.0
2018-12	RAN#82	RP-182373	5308	1	B	CR: Addition of performance requirements for 8Rx	15.5.0
2018-12	RAN#82	RP-182373	5309	1	B	CR: Addition of SDR test for 8Rx	15.5.0
2018-12	RAN#82	RP-182368	5312	1	B	CR: SDR test cases with 1024QAM DL	15.5.0
2018-12	RAN#82	RP-182368	5313	1	B	CR: For 1024QAM DL CSI requirements	15.5.0
2018-12	RAN#82	RP-182388	5314	2	F	CR for 36.101: PC2 UTRA ACLR exemption list update	15.5.0
2018-12	RAN#82	RP-182388	5317	2	F	CR for 36.101: Introduction of a PC3 UTRA ACLR exemption list	15.5.0
2018-12	RAN#82	RP-182388	5318	1	F	CR to TS 36.101 – revision of OOB for B42	15.5.0
2018-12	RAN#82	RP-182388	5319	2	F	CR to TS 36.101 – Add RF requirements for CA 66C	15.5.0
2018-12	RAN#82	RP-182373	5320		B	CR: Addition of CQI tests for 8Rx	15.5.0
2018-12	RAN#82	RP-182376	5195	1	B	Introduction of band 53 into TS 36.101	16.0.0
2018-12	RAN#82	RP-182375	5202		B	Introducing CR on new xDL/2UL CA band combinations in TS36.101 rel-16	16.0.0
2018-12	RAN#82	RP-182375	5208		B	Introduction of LTE inter-band Carrier Aggregation for x bands DL (x=4, 5) with 1 band UL to TS36.101	16.0.0
2018-12	RAN#82	RP-182377	5220		B	CR of adding LTE B65 for UE category NB1 and NB2 in R16	16.0.0
2018-12	RAN#82	RP-182375	5292		B	Introduction of Rel-16 LTE inter-band CA for 2 bands DL with 1 band UL combinations in TS36101	16.0.0
2018-12	RAN#82	RP-182375	5297		B	Introduction of completed LTE CA for 2 bands DL with 2 band into Rel-16 TS 36.101	16.0.0
2018-12	RAN#82	RP-182375	5300		B	Introduction of Rel-16 LTE Intra-band combinations in 36.101	16.0.0
2018-12	RAN#82	RP-182375	5302		B	Introduction of completed LTE CA for 3 bands DL with 1 bands UL into Rel-16 TS 36.101	16.0.0
2019-03	RAN#83	RP-190401	5327	1	A	V2X UE protection to NR bands in TS36.101	16.1.0
2019-03	RAN#83	RP-190405	5374		A	Correction of UE demodulation requirements for SPDCCH	16.1.0
2019-03	RAN#83	RP-190405	5376		A	Correction of UE demodulation requirements for Slot/Subslot-PDSCH	16.1.0
2019-03	RAN#83	RP-190405	5378		A	Correction of sTTI CQI reporting test	16.1.0
2019-03	RAN#83	RP-190406	5362		A	CR: Addition of performance requirements for FeNB-IoT TDD NPBCH(Rel-16)	16.1.0
2019-03	RAN#83	RP-190406	5366		A	CR: Addition of performance requirements for FeNB-IoT TDD NPDSCH(Rel-16)	16.1.0
2019-03	RAN#83	RP-190406	5364	1	A	CR: Addition of performance requirements for FeNB-IoT TDD NPDCCH(Rel-16)	16.1.0
2019-03	RAN#83	RP-190408	5352		A	CR: Addition of FRC for 8Rx(Rel-16)	16.1.0
2019-03	RAN#83	RP-190408	5354		A	CR: Updates to the applicability and test rule for 8Rx capable UE(Rel-16)	16.1.0
2019-03	RAN#83	RP-190408	5356		A	CR: Updates to 8Rx demodulation performance requirements(Rel-16)	16.1.0
2019-03	RAN#83	RP-190408	5358		A	CR: Updates to 8Rx SDR tests(Rel-16)	16.1.0
2019-03	RAN#83	RP-190408	5360		A	CR: Updates to 8Rx CQI tests(Rel-16)	16.1.0
2019-03	RAN#83	RP-190409	5324		B	Introducing CR on new x bands (x=3,4,5) DL with 2 bands UL inter-band CA in TS36.101 rel-16	16.1.0
2019-03	RAN#83	RP-190409	5329		B	Introduction of LTE inter-band Carrier Aggregation for x bands DL (x=4, 5) with 1 band UL to TS36.101	16.1.0
2019-03	RAN#83	RP-190409	5347		B	Introduction of Rel-16 LTE inter-band CA for 2 bands DL with 1 band UL combinations in TS36101	16.1.0
2019-03	RAN#83	RP-190409	5388		B	Introduction of Rel-16 LTE Intra-band combinations in 36.101	16.1.0
2019-03	RAN#83	RP-190409	5402		B	Introduction of completed LTE CA for 3 bands DL with 1 bands UL into Rel-16 TS 36.101	16.1.0
2019-03	RAN#83	RP-190411	5341		A	CR on protection Band 32, 75 and 76 for Band 28 and corresponding band combinations	16.1.0
2019-03	RAN#83	RP-190414	5372		A	CR: Correction to 4Rx TDD CQI TC 9.9.1.4.2 (Rel-16)	16.1.0
2019-03	RAN#83	RP-190415	5336		A	CR on absolut power tolerance for V2X	16.1.0

2019-03	RAN#83	RP-190415	5401		A	Correction of PCmax requirement for V2X	16.1.0
2019-03	RAN#83	RP-190415	5344	1	A	Corrections to Rel-16 CA configurations	16.1.0
2019-03	RAN#83	RP-190420	5349		A	CR to 36.101: frequency offset between anchor and non-anchor carrier for TDD NB-IoT standalone operation	16.1.0
2019-03	RAN#83	RP-190420	5368		A	CR: Updates to test cases for 1024QAM (Rel-16)	16.1.0
2019-03	RAN#83	RP-190420	5385		A	CR for TDD requirements for network-based CRS interference mitigation (Rel-16)	16.1.0
2019-03	RAN#83	RP-190420	5323	1	A	CR to 36.101 on simulation parameters and FRCs for 1024QAM testcases	16.1.0
2019-03	RAN#83	RP-190421	5380		A	Correction of PDSCH demodulation requirements for eFeMTC	16.1.0
2019-03	RAN#83	RP-190421	5382		A	Correction of CQI reporting test requirements for eFeMTC	16.1.0
2019-03	RAN#83	RP-190422	5331		A	Editorial correction R15 CA	16.1.0
2019-03	RAN#83	RP-190422	5406		A	Correction on eV2X demodulation requirements	16.1.0
2019-03	RAN#83	RP-190422	5405		A	CR TS 36.101 Update of LAA REFSENS exclusion region for B25 and B12	16.1.0
2019-03	RAN#83	RP-190422	5403		A	CR TS 36.101 Introduction of a PC3 UTRA ACLR exemption list for CA	16.1.0
2019-03	RAN#83	RP-190422	5333	1	A	CA Rx requirement for more than five downlink carriers	16.1.0
2019-03	RAN#83	RP-190422	5346	1	A	Corrections to Rel-16 CA configurations	16.1.0
2019-03	RAN#83	RP-190422	5383	1	A	Alignment of Foob related description for 36.101	16.1.0
2019-03	RAN#83	RP-190422	5408	1	A	CR to 36.101 for CA configuration on CA_3A-41C-42C	16.1.0
2019-06	RAN#84	RP-191261	5413	1	A	CR to exclude 100kHz for NBIOT for B26 band edge operation	16.2.0
2019-06	RAN#84	RP-191266	5415	2	A	CR for 36.101 adding band 46 for Rx spurious emissions(Rel-16)	16.2.0
2019-06	RAN#84	RP-191266	5421		A	Finalize UE demodulation requirements for CRS-IM	16.2.0
2019-06	RAN#84	RP-191266	5423		A	Finalize UE demodulation requirements for sTTI	16.2.0
2019-06	RAN#84	RP-191266	5425		A	Finalize CQI reporting test for sTTI	16.2.0
2019-06	RAN#84	RP-191267	5427		A	Editorial corrections for 36.101 CA OOB additional spectrum emission requirements	16.2.0
2019-06	RAN#84	RP-191266	5431		A	Update 4Rx Requirement for Band 30	16.2.0
2019-06	RAN#84	RP-191264	5435	1	A	CR for correcting A-MPR for subPRB for CAT-M1 and CAT-M2 type A	16.2.0
2019-06	RAN#84	RP-191264	5437		A	CR: Updates to V2X test applicability(Rel-16)	16.2.0
2019-06	RAN#84	RP-191265	5441		A	CR on antenna configurations for NB-IoT demodulation performance requirements (Rel-16)	16.2.0
2019-06	RAN#84	RP-191255	5444		B	Introduction of completed LTE CA for 2 bands DL with 2 bands UL into Rel-16 TS 36.101	16.2.0
2019-06	RAN#84	RP-191266	5446	1	A	Shadow CR for TS 36.101: CA_NS_04 A-MPR Corrections (Rel-16)	16.2.0
2019-06	RAN#84	RP-191258	5447	1	F	CR for TS 36.101: Add B25 MSD for CA_25-41	16.2.0
2019-06	RAN#84	RP-191256	5449	1	B	Introduction of bands 87 and 88 into TS 36.101	16.2.0
2019-06	RAN#84	RP-191259	5453		A	Correction to demodulation of PDCCCH for LAA	16.2.0
2019-06	RAN#84	RP-191266	5455		A	CR: cleanup for LTE 8Rx DL (Rel-16)	16.2.0
2019-06	RAN#84	RP-191255	5458		B	Introduction of completed LTE CA for 2 bands DL with 2 bands UL into Rel-16 TS 36.101	16.2.0
2019-06	RAN#84	RP-191261	5461	1	A	CR to Rel-16 TS 36.101 CA_NS_08 A-MPR	16.2.0
2019-06	RAN#84	RP-191255	5465		B	Introduction of LTE inter-band Carrier Aggregation for x bands DL (x=4, 5) with 1 band UL to TS36.101	16.2.0
2019-06	RAN#84	RP-191267	5470		A	CR to TS 36.101 - NB-IoT REFSENS requirement being band agnostic	16.2.0
2019-06	RAN#84	RP-191259	5474		A	Correction to demodulation of PDSCH LAA	16.2.0
2019-06	RAN#84	RP-191255	5475		B	Introducing CR on new x bands (x=3,4,5) DL with 2 bands UL inter-band CA in TS36.101 rel-16	16.2.0
2019-06	RAN#84	RP-191255	5476		B	Introducing CR on new x bands (x=3,4,5) DL with 2 bands UL inter-band CA in TS36.101 rel-16	16.2.0
2019-06	RAN#84	RP-191255	5478		B	Introduction of completed R16 3DL band combinations to TS 36.101	16.2.0
2019-06	RAN#84	RP-191255	5480	1	B	Introduction of Rel-16 LTE inter-band CA for 2 bands DL with 1 band UL combinations in TS36101	16.2.0
2019-09	RAN#85	RP-192056	5484		A	Correction to reference sensitivity for Band 74	16.3.0
2019-09	RAN#85	RP-192056	5490		A	CR to 36.101 rel. 16 to fix Out-of-band Blocking issue for bands 51, 76	16.3.0
2019-09	RAN#85	RP-192051	5494		A	Correction to RMC for Cat M1 CSI tests	16.3.0
2019-09	RAN#85	RP-192041	5495	3	B	CR: Demod test definition for HST in 500km/h speed	16.3.0
2019-09	RAN#85	RP-192056	5497		A	CR to 36.101 NS_40, NS_41, NS_42 spurious emission requirement	16.3.0
2019-09	RAN#85	RP-192045	5498		B	Introduction of PC2 for Category HD-FDD M1 and M2 UE operating on bands 31 and 72	16.3.0
2019-09	RAN#85	RP-192051	5502		A	CR for Narrowband blocking for LTE CatM1/M2	16.3.0
2019-09	RAN#85	RP-192042	5503	1	B	Introduction of LTE-A inter-band CA Rel-16 for new x bands (x=3,4,5) DL with 2 bands UL to TS36.101	16.3.0
2019-09	RAN#85	RP-192052	5506		A	Correction to B70 UE Co-existence	16.3.0

2019-09	RAN#85	RP-192042	5511		B	Introduction of LTE inter-band Carrier Aggregation for x bands DL (x=4, 5) with 1 band UL to TS36.101	16.3.0
2019-09	RAN#85	RP-192042	5512		B	Introduction of completed R16 3DL band combinations to TS 36.101	16.3.0
2019-09	RAN#85	RP-192052	5513	1	A	CR for 36.101 Pcmx for V2X_v16	16.3.0
2019-09	RAN#85	RP-192043	5519	1	B	CR of adding LTE B42/B43 for UE category NB1/NB2 and CAT_M1/M2 in R16	16.3.0
2019-09	RAN#85	RP-192043	5520	1	B	CR of adding LTE B7 for UE category NB1/NB2 in R16	16.3.0
2019-09	RAN#85	RP-192042	5521		B	Introduction of Rel-16 LTE inter-band CA for 2 bands DL with 1 band UL combinations in TS36101	16.3.0
2019-09	RAN#85	RP-192056	5522		A	CR for 36.101: adding spurious emission band UE co-existence for CA_1-41	16.3.0
2019-09	RAN#85	RP-192042	5524	1	F	Rel-16 CR to 36.101 to correct typos	16.3.0
2019-09	RAN#85	RP-192056	5526	1	A	Update NS_40 into TS 36.101	16.3.0
2019-09	RAN#85	RP-192056	5527	1	A	Update NS_42 into TS 36.101	16.3.0
2019-09	RAN#85	RP-192042	5529		B	Introduction of completed LTE CA for 2 bands DL with 2 bands UL into Rel-16 TS 36.101	16.3.0
2019-12	RAN#86	RP-193046	5537		A	CR: Updates to HST-SFN channel model (Rel-16)	16.4.0
2019-12	RAN#86	RP-193044	5552	1	F	CR to 36.101 to revise LTE CA_NS_04 AMPR for BW class D	16.4.0
2019-12	RAN#86	RP-193043	5555		A	CR to 36.101 to revise CA_NS_04 AMPR for BW Class C	16.4.0
2019-12	RAN#86	RP-193043	5558		A	CR to 36.101 rel. 15 to fix Out-of-band Blocking issue for bands 38, 41	16.4.0
2019-12	RAN#86	RP-193043	5560		A	CR to 36.101 rel. 15 to fix Out-of-band Blocking issue for bands 32	16.4.0
2019-12	RAN#86	RP-193027	5561		B	Introduction of LTE inter-band Carrier Aggregation for x bands DL (x=4, 5) with 1 band UL to TS36.101	16.4.0
2019-12	RAN#86	RP-193027	5562		D	Remove double entry of CA_41F	16.4.0
2019-12	RAN#86	RP-193049	5564		A	Correction of Note number in Table 5.6.1-1	16.4.0
2019-12	RAN#86	RP-193046	5567		A	DeltaTib for CA_1-7-46	16.4.0
2019-12	RAN#86	RP-193046	5570		A	CR for correction on Rel-14 eFDMIMO PMI test cases with advanced codebook for TS 36.101 (Rel-16)	16.4.0
2019-12	RAN#86	RP-193044	5571	3	B	Adding Band40 for UE category 1bis into Rel-16 TS 36.101	16.4.0
2019-12	RAN#86	RP-193027	5573		B	Introduction of LTE-A inter-band CA for x bands (x=3,4,5) DL with 2 bands UL into TS36.101	16.4.0
2019-12	RAN#86	RP-193043	5578		A	Correction to intraband contiguous CA in-band and out-of-band blocking tables REL-16	16.4.0
2019-12	RAN#86	RP-193026	5579	1	B	CR on introducing UE demodulation tests for 500km/h velocity	16.4.0
2019-12	RAN#86	RP-193026	5580	1	B	Introduction of CA PDSCH demodulation requirements with HST-SFN	16.4.0
2019-12	RAN#86	RP-193023	5581	1	B	CR to TS 36.101 - NB-IoT in NR in-band support clarifications	16.4.0
2019-12	RAN#86	RP-193027	5583		B	Introduction of Rel-16 LTE inter-band CA for 2 bands DL with 1 band UL combinations in TS36101	16.4.0
2019-12	RAN#86	RP-193026	5584	1	B	CR for Addition of test applicability rule for LTE HST CA test(Rel-16)	16.4.0
2019-12	RAN#86	RP-193027	5587		B	Introduction of completed R16 3DL band combinations to TS 36.101	16.4.0
2019-12	RAN#86	RP-193046	5588		A	CR for 36.101 UE-to-UE coexistence for V2X_v16	16.4.0
2020-03	RAN#87-e	RP-200414	5591		B	Introduction of LTE inter-band Carrier Aggregation for x bands DL (x=4, 5) with 1 band UL to TS36.101	16.5.0
2020-03	RAN#87-e	RP-200414	5593		A	Mirror CR for 36.101: Missing Pcmx tolerance for 23-33 dBm in Table 6.2.5A-2 and Table 6.2.5B-1	16.5.0
2020-03	RAN#87-e	RP-200412	5596		F	CR to TS 36.101: Finalization on PDSCH demodulation with 500km/h velocity	16.5.0
2020-03	RAN#87-e	RP-200414	5599		B	Introduction of Rel-16 LTE inter-band CA for 2 bands DL with 1 band UL combinations in TS36101	16.5.0
2020-03	RAN#87-e	RP-200500	5601		B	Introduction of completed R16 3DL band combinations to TS 36.101	16.5.0
2020-03	RAN#87-e	RP-200416	5602	1	B	CR for TS 36.101-1 Introduction of new SRS requirements for LTE eMIMO	16.5.0
2020-03	RAN#87-e	RP-200384	5595	1	B	Introducing new channel bandwidth for band n28	16.5.0
2020-06	RAN#88	RP-201060	5608		A	CR Coexistence cleanup for 36101 Rel16	16.6.0
2020-06	RAN#88	RP-200988	5613		A	CR for TS 36.101: CR for spec corrections for MSD table	16.6.0
2020-06	RAN#88	RP-201060	5615		A	Corrections of CA band combo table	16.6.0
2020-06	RAN#88	RP-200988	5618		A	Mirror CR for 36.101: fix modifiedMPRbehavior for NS_31	16.6.0
2020-06	RAN#88	RP-201060	5619		B	Introduction of LTE-A inter-band CA for x bands (x=3,4,5) DL with 2 bands UL to TS36.101	16.6.0
2020-06	RAN#88	RP-200961	5620		B	Adding Band34 for UE category 1bis into Rel-16 TS 36.101	16.6.0
2020-06	RAN#88	RP-200988	5622		A	CR: Updates to FeNB-IoT UE performance requirements in 36.101 (Rel-16)	16.6.0
2020-06	RAN#88	RP-200991	5627		A	CR: Updates to LTE CQI test cases 9.2.1.7 and 9.2.1.8 (Rel-16)	16.6.0

2020-06	RAN#88	RP-200988	5629		A	CR: Introduction for intra-band contiguous CA performance requirements for FDD with minimum channel spacing (Rel-16)	16.6.0
2020-06	RAN#88	RP-201060	5633		B	Introduction of Rel-16 LTE inter-band CA for 2 bands DL with 1 band UL combinations in TS36101	16.6.0
2020-06	RAN#88	RP-200988	5636		A	CR to remove TBD and bracket on CAT-M2 Type A for Rel-16	16.6.0
2020-06	RAN#88	RP-201060	5638		F	CR Rel-16 for editorial corrections TS 36.101	16.6.0
2020-06	RAN#88	RP-200967	5639		F	CR for Band 53 NS_45 requirement and OOB blocking	16.6.0
2020-06	RAN#88	RP-201045	5640	1	B	Addition of UE coexistence between US bands and NR Band n77	16.6.0
2020-06	RAN#88	RP-201060	5641		B	Introduction of completed R16 3DL band combinations to TS 36.101	16.6.0
2020-06	RAN#88	RP-201060	5646		B	Introduction of completed LTE CA for 2 bands DL with 2 bands UL into Rel-16 TS 36.101	16.6.0
2020-06	RAN#88	RP-200989	5649		A	CR to remove TBD for A-MPR for NS_33 in 36.101 Rel-16	16.6.0
2020-06	RAN#88	RP-200988	5651		A	CR to remove TBD in in clause 6.6.3 in 36.101 Rel-16	16.6.0
2020-09	RAN#89	RP-201512	5653		A	Correction to band 85 spurious emission limits UE co-existence	16.7.0
2020-09	RAN#89	RP-201535	5654	1	F	Coexistence cleanup for 36101 Rel16	16.7.0
2020-09	RAN#89	RP-201512	5656	2	F	A-MPR definition for CA_48B	16.7.0
2020-09	RAN#89	RP-201512	5659		A	Correction of OCNB configuration for LAA SDR requirements	16.7.0
2020-09	RAN#89	RP-201512	5661		A	Addition of applicability for MTC UE capable of 64QAM DL	16.7.0
2020-09	RAN#89	RP-201508	5662	1	B	Introduction of enhanced MPDCCH demodulation requirements	16.7.0
2020-09	RAN#89	RP-201508	5663	1	B	Introduction of CSI-RS based PMI reporting test for non-BL UEs	16.7.0
2020-09	RAN#89	RP-201512	5667		F	Correction of band combinations table in Rel-16	16.7.0
2020-09	RAN#89	RP-201510	5669	1	B	CR to 36.101: Introduction of LTE based 5G terrestrial broadcast numerologies	16.7.0
2020-09	RAN#89	RP-201512	5670		A	Update to NB-IOT aggregate power control tolerance for TDD	16.7.0
2020-09	RAN#89	RP-201510	5671	1	B	CR addition on LTE-based 5G terrestrial broadcast	16.7.0
2020-09	RAN#89	RP-201509	5672	1	B	CR: Introduce NPDSCH performance requirements for multi-TB interleaved transmission.	16.7.0
2020-09	RAN#89	RP-201535	5673		F	CR to 36.101 Removal band 10 protection	16.7.0
2020-09	RAN#89	RP-201535	5675		F	CR to 36.101 Correction to CA_NS_10	16.7.0
2020-12	RAN#90	RP-202484	5676		F	Correction of B88 UL EARFCN	16.8.0
2020-12	RAN#90	RP-202493	5682	1	A	Clarifications and corrections on UE co-ex requirements(R16)	16.8.0
2020-12	RAN#90	RP-202484	5683		F	LTE CA corrections	16.8.0
2020-12	RAN#90	RP-202482	5684		F	Band 88 and 87 bracket removal	16.8.0
2020-12	RAN#90	RP-202484	5686		F	Coexistence cleanup for 36101 Rel16	16.8.0
2020-12	RAN#90	RP-202498	5690		A	CR for 36.101 to clarify the SCS supports for LTE MBMS (Rel-16)	16.8.0
2020-12	RAN#90	RP-202512	5693	1	A	CR on cleanup for LTE FeMBMS(Rel-16)	16.8.0
2020-12	RAN#90	RP-202481	5694	1	F	CR on cleanup for LTE-based 5G terrestrial broadcast	16.8.0
2020-12	RAN#90	RP-202474	5696	1	F	CR: Cleanup for NPDSCH performance requirements for multi-TB interleaved transmission in TS 36.101	16.8.0
2020-12	RAN#90	RP-202492	5698	2	A	CR for 36.101: Cleanup for performance requirements of sTTI (Rel-16)	16.8.0
2020-12	RAN#90	RP-202473	5700		F	Clean up of enhanced MPDCCH demodulation requirements	16.8.0
2020-12	RAN#90	RP-202473	5701	1	F	Clean up of CSI-RS based PMI reporting test for non-BL UEs	16.8.0
2020-12	RAN#90	RP-202510	5703	1	A	CR Correction to B72 coex - CA_NS_08 - Band 10 protection 36.101 Rel16	16.8.0
2020-12	RAN#90	RP-202477	5707	1	F	CR for editorial corrections 36.101	16.8.0
2020-12	RAN#90	RP-202477	5708		F	CR for 36.101: Corrections for UL CA_41D	16.8.0
2020-12	RAN#90	RP-202476	5709		B	Introduction of completed R17 3DL band combinations to TS 36.101	16.8.0



---

## History

<b>Document history</b>		
V16.6.0	August 2020	Publication
V16.7.0	December 2020	Publication
V16.8.0	February 2021	Publication